

IMAGINE.

CREATE.

A Range of Design Options.



MT Architectural
INDUSTRIES Wood Doors

FACTORY FINISHES

IMAGINATIVE
DESIGNS FOR AN
IMPRESSIVE FINISH.



When it comes to your design project, every detail matters. That's why VT crafts every door with meticulous attention to beauty and expression. Combined with our wide array of finish options, we're able to create architectural wood doors that elevate the aesthetics and performance of your project. All doors are made to your exact specifications to meet your performance and design standards.

For projects that command beauty and distinction without compromise, VT's Artistry Collection offers unparalleled elegance. Our Artistry Division is capable of producing a unique finish for a wide range of custom-tailored doors ranging from oversized to flush to custom stile & rail.

When designing for beauty, VT's Heritage Collection is a compelling choice. From specialty veneers to profiled doors, our Heritage Collection offers a unique combination of style, quality and performance.

And with every door we sell, you can always count on customer service that's second-to-none and consistent, industry-best lead times—often as fast as 2-3 weeks.

HERITAGE COLLECTION

STYLE MEETS DURABILITY

Extraordinary craftsmanship. Natural beauty. Durable performance. VT's Heritage Door Collection offers a perfect balance of style and performance.

Featuring a complete catalog of factory finishes to choose from, we're confident you'll find a door to perfectly complement any design.

- UV cured factory finish to meet WDMA TR-8 and AWS System 9 is standard.
- For high-profile projects, custom color matching available.
- A wide variety of VT color choices is available with only a 2-3 week lead time.
- Three sealer coats and two topcoats shield and protect flush doors.
- Advanced computer automation flawlessly applies each coat, and a computer-controlled automatic system provides durable, even coats.
- Optional anti-microbial coating available.

HOW TO SPECIFY HERITAGE DOORS

WDMA TR-8/AWS System 9 UV cured acrylated polyurethane. The polyurethane shall be UV cured to produce a finish per WDMA I.S. 1-A/AWS Section 5. Top and bottom rails shall be factory sealed with an approved wood sealer. Specify the finish.

HERITAGE PROTECTIVE COATING PROCESS

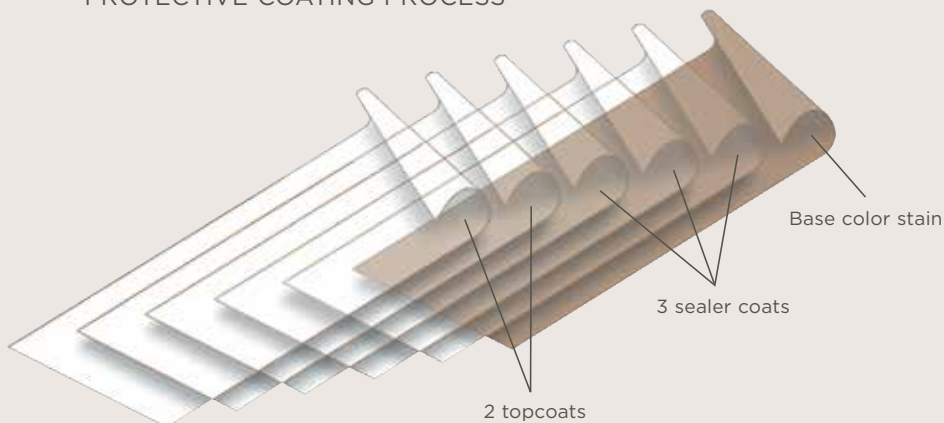

ARTISTRY COLLECTION

STUNNING ARTISTRY. PREMIUM PERFORMANCE

For projects where only premium style will suffice, VT's Artistry Collection is there. Each Artistry door is hand-crafted to your exact specifications, all the way down to custom color and hand-finish.

The Artistry Collection's superior finish system provides impressive durability over the life of the door, keeping it beautiful for years to come.

- AWS System 2/WDMA TR-2 pre-catalyzed lacquer finish is standard.
- Oil based stain is either hand-sprayed or hand-wiped and achieves a furniture grade finish.
- Artisans tailor the finish process to the individual species of veneers being used to create the ultimate furniture grade finish.
- Multiple sheen options available, including opaque lacquer finish to meet customer vision.
- The transparent pre-catalyzed lacquer finish provides a warm, vibrant finish that extols the virtues and beauty of the wood.
- Perfect for high-end applications and is used to enhance the beauty and intricacy of craftsmanship of the doors.

HOW TO SPECIFY ARTISTRY DOORS

AWS System 2/WDMA TR-2 pre-catalyzed lacquer finish. The lacquer shall be cured to produce a finish per AWS Section 5/WDMA I.S. 1A. Top and bottom rails shall be factory sealed with an approved wood sealer. Specify the finish.

ARTISTRY PROTECTIVE COATING PROCESS

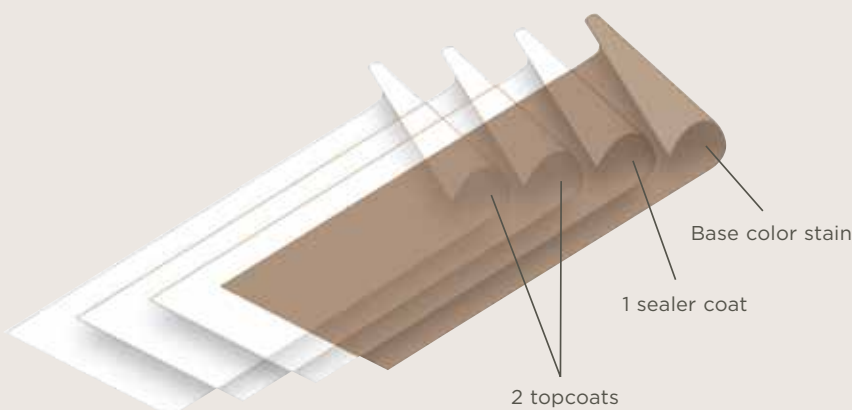

FINISH OPTIONS.

VT finishes not only complement the distinctive beauty of the doors but also enhance their outstanding durability. Our factory finishes can be UV cured and formulated to provide a tough shell of protection.

CUSTOM OPTIONS

VT offers a wide variety of factory color choices, available on a quick turnaround, to meet your design considerations. Samples may be requested through your VT sales representative. Custom color matching is also available for high-profile projects. Simply send us a 3" x 5" physical sample of the finish color you desire, and we'll match it to meet your project needs.

EXOTIC OPTIONS

If your design calls for specialty wood veneer, VT's Artistry Collection can make it happen. We have the capability to manufacture high-quality doors to your exact design needs and specifications. Using high-end or exotic veneers, we'll provide the perfect specialty veneer door for your project.

NEW FINISHES

Color trends are always changing in the design world, and our new finish colors expand the already existing options to enhance your project choices. For 2015, VT has introduced five new finishes to our standard finishes line: Chocolate, Riverstone, Onyx, Serengeti and Restoration.



VT COLOR CHOICE PROCESS



NATURAL VS. SELECT WHITE

Certain wood veneers—most notably maple, birch and ash—contain both heartwood and sapwood when natural is specified. These heartwood/sapwood combinations can create marked color contrasts across the finished face veneer, possibly causing an undesirable effect. By specifying “select white” veneer, only sapwood will be used so color variations will be minimized, thus creating a more uniform appearance across the door face.



“Natural” face veneer



“Select White” face veneer

CONSISTENT AND BEAUTIFUL FINISHES

Streamline the color matching process for your project by selecting from VT’s popular color choices (see color swatches in this brochure). To ensure satisfaction, order a free sample to review before making your final decisions. You’ll save time and money, and the result will be a consistent, beautiful finish. For a custom finish, simply send us a 3” x 5” physical sample of the finish color desired, and we will custom match it to meet your project needs.

| FINISH OPTIONS | WDMA | AWS |
|------------------------------------|------|----------|
| Flush - HERITAGE COLLECTION | TR-8 | System 9 |
| Stile & Rail - HERITAGE COLLECTION | TR-8 | System 9 |
| Flush - ARTISTRY COLLECTION | TR-2 | System 2 |
| Stile & Rail - ARTISTRY COLLECTION | TR-2 | System 2 |

COLOR AND FINISH OPTIONS AVAILABLE FROM VT ARCHITECTURAL WOOD DOORS FOR THE HERITAGE AND ARTISTRY COLLECTIONS.

RED OAK



ALPINE AL07



CLEAR CL07



CHOCOLATE CH15



SERENGETI SE15



GRASSLAND GR07



OASIS OA07



RIVERSTONE RI15



RESTORATION RE15

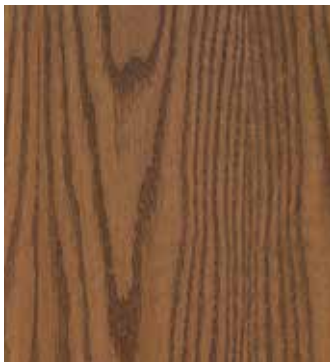

RAVINE RA07



SAVANNA SA07



ONYX ON15



TIMBER TI07



WHEAT WH07



RED OAK
(RAVINE FINISH)



To ensure satisfaction, order a free sample to review before making your final decision. VT Industries distributors stock 3" x 5" samples to expedite the color approval process. Please contact your sales representative or distributor to request physical samples. This brochure should not be used for final color selection.

SELECT WHITE BIRCH



ALPINE AL07



CLEAR CL07



CHOCOLATE CH15



SERENGETI SE15



GRASSLAND GR07



OASIS OA07



RIVERSTONE RI15



RESTORATION RE15



PLAIN SLICED SELECT WHITE BIRCH
(CLEAR FINISH)



RAVINE RA07



SAVANNA SA07



ONYX ON15



TIMBER TI07



WHEAT WH07

NATURAL BIRCH



ALPINE AL07



CLEAR CL07



CHOCOLATE CH15



SERENGETI SE15



GRASSLAND GR07



OASIS OA07



RIVERSTONE RI15



RESTORATION RE15



RAVINE RA07



SAVANNA SA07



ONYX ON15



TIMBER TI07



WHEAT WH07

NATURAL BIRCH
(CLEAR FINISH)



SELECT WHITE MAPLE



ALPINE AL07



CLEAR CL07



CHOCOLATE CH15



SERENGETI SE15



GRASSLAND GR07



OASIS OA07



RIVERSTONE RI15



RESTORATION RE15



RAVINE RA07



SAVANNA SA07



ONYX ON15



QUARTERED WHITE MAPLE 2 (FLAT)
PANEL STILE & RAIL DOOR WITH
SQUARE STICKING (CLEAR FINISH)



TIMBER TI07



WHEAT WH07

MAHOGANY



ALPINE AL07



CLEAR CL07



CHOCOLATE CH15



SERENGETI SE15



GRASSLAND GR07



OASIS OA07



ONYX ON15



RAVINE RA07



SAVANNA SA07



TIMBER TI07



WHEAT WH07



PLAIN SLICED MAHOGANY
STILE & RAIL (TIMBER FINISH)

CHERRY



ALPINE AL07



CLEAR CL07



CHOCOLATE CH15



SERENGETI SE15



GRASSLAND GR07



OASIS OA07



RIVERSTONE RI15



RAVINE RA07



PLAIN SLICED CHERRY 5 PANEL
(RAISED & RIM BANDED) WITH
OGEE STICKING (SAVANNA FINISH)



SAVANNA SA07



ONYX ON15



TIMBER TI07



WHEAT WH07



VT Industries is committed to providing superior craftsmanship and exceptional service with every door. Family-owned since 1956, we've grown to become a leading manufacturer in architectural wood doors, offering a dynamic lineup of products that makes it easy to choose the right door type for your specific project.

1000 INDUSTRIAL PARK | P.O. BOX 490 | HOLSTEIN, IA 51025
P 800.827.1615 EXT. 268 | F 712.368.4163 | DOOR_INFO@VTINDUSTRIES.COM
VTDOORS.COM



For detailed information on the doors you've seen in this brochure, please visit vtdoors.com.

©2015 VT Industries, Inc. All rights reserved.

NPFF-0115