

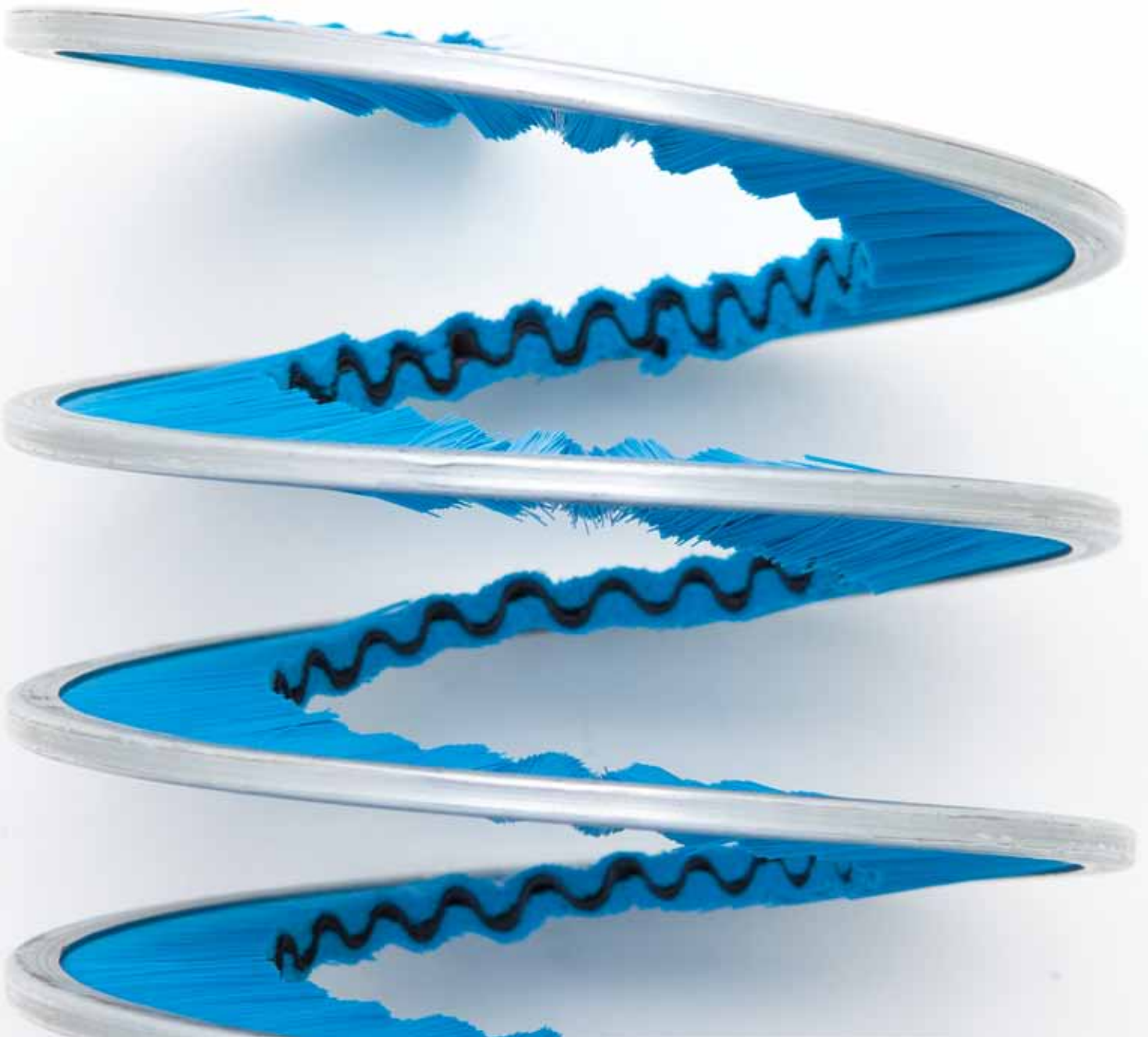

**SEALEZE®**

Problem solved.

## Industrial Applications



## Contents

<b>About Us</b>	<b>2</b>
<b>Introduction to Brush</b>	<b>2</b>
<b>Typical Applications</b>	<b>3</b>
Stock Nylon Filament Brushes	4
Stock Aluminum Holders	5
Static Control Brushes	6
<b>Formed Brushes</b>	<b>7</b>
How to Order Formed Brushes	7
Cup Forms	8
Arc Forms	9
Coil Forms	10
Spiral Forms	11
Mounting Tabs	11
<b>Specialty Brush Products</b>	
Metal Filament Brushes	12
Wire Descaling Brushes	13
Ez-Flex® Flexible Strip Brush	14
Lever Seal Brush	15
and Holders	
CoolBalance® for Data Center	15
Cable Management	
Rotary Brushes	16
XtraSeal® Brushes	16
Natural Fiber Brushes	17
Punching Options	17
Brushes for Elevated	18
Temperatures	
<b>Customizing Brushes</b>	<b>19</b>
<b>to Your Needs</b>	
<b>Staple Set Brushes</b>	<b>20</b>
General Guidelines for Choosing	21
Staple Set Brushes	
<b>Selecting the Right Brush</b>	<b>22</b>
<b>Help and How to Order</b>	<b>23</b>

## About Us

Sealeze solves problems to help our customers succeed. The means: brush. The end: results.

“Customers first” at Sealeze isn’t just lip service. We understand what is important to our customers: quality products that solve their problems, short lead times, fast quotes, and promised delivery dates that can be counted on. Everything we do is to meet a single end – meeting all our customer’s needs and expectations.

We create solutions that address specific needs. We continually raise the bar for customer-focused innovation, drawing on a highly-skilled staff with a unique problem-solving mindset, and the broadest inventory of brush sizes, filament types, and materials in the industry.

Sealeze got its start in the 1970s as the first US distributor of strip brush for weatherseal applications. In the years since, we have become the foremost innovator in brush solutions for a broad range of applications. Sealeze joined the Jason Incorporated family of companies in 1999.

### ISO 9001 Certified

Sealeze has been ISO certified since 1997 and today holds ISO 9001 certification. Everyone at Sealeze is part of the ISO experience – marketing, sales, accounting, purchasing, engineering, customer service, shipping/receiving, and manufacturing. It is not just a manufacturing system, but a company-wide way of doing business that puts the needs of our customers as the focus of what we do. ISO is not just a one-time event, it is one step in a continuous improvement process that also utilizes Lean Manufacturing principles to reduce waste and improve quality.

# Introduction to Brush

Sealeze provides brush-based solutions for a wide variety of industrial applications. For more than a quarter of a century, Sealeze brush products have reduced costs in manufacturing processes and improved the performance of our customers' products. Our brush can be found in a range of applications, including shielding on machine tools, guides on conveyor systems, cable management and air seals in electronic cabinets, sweeping applications in turf care and much more. We manufacture each type of brush in a variety of sizes, construction materials and filament types and diameters. Our

## Our Solutions

**Strip Brush** (metal-backed) is available in the broadest range of brush sizes, construction materials and filament diameters. Our standard strip brush includes galvanized steel backing with nylon filament. Stainless steel construction is also available as well as a large variety of filaments in synthetic, natural, conductive and metal.

**EZ-Flex® Strip Brush** (flexible backing in either nylon or polypropylene) is a durable, light-weight option to metal-backed brush.

**Brush Holders** in anodized aluminum, stainless steel and polypropylene. We can form brushes and holders for precise mounting in your application and provide mounting holes and finishes to your print specifications. Some of our formed products include internal and external spirals, coils, arcs, cup forms and lever seals.

**Staple Set** (sometimes called punch brush) in a wide variety of filament and filament patterns, substrate materials and designs, including strip, cylinder (radial), disc, head (goblet) and block (lag). Substrate, filament materials and designs are chosen to best meet your application needs. Substrates can be custom-shaped to your drawings from materials such as nylon, polypropylene, HDPE, wood and more. Filament choices include nylon, polypropylene, horse hair, and more.

**Application support** from our team of experienced sales representatives and in-house engineers help you identify the exact construction, filament and material requirements for your application.

brushes and holding systems can be custom designed and manufactured to exacting specifications to meet your specific needs. To meet the requirements of this broad range of applications, Sealeze offers three different brush constructions: metal-backed strip, flexible-backed strip, and staple set. Each type of brush has its own unique characteristics that make it the most suitable for an application.

To learn more about how to select the best brush for your application, refer to "Selecting the Right Brush" on page 22.

**Customers are first** at Sealeze, from short lead times to quick quotes and delivery you can count on, many of the products we offer are stocked and ready for immediate delivery. Even our "custom-formed products" when made within the IDs and ODs shown in this catalog are manufactured with stock materials. In-house CNC machining, milling, welding and forming capabilities, combined with our approach to LEAN manufacturing, enables us to meet the most demanding production schedules so delivery is made in the shortest possible time. Many requests for quote are responded to immediately, and most within 24 hours. And, with an average on-time, as promised delivery of over 98%, you can count on getting your product when you need it.

At Sealeze, we constantly strive to provide the highest quality products and services, continuously monitoring and improving our processes and performance to make sure we meet or exceed your expectations. Our ISO 9001 certification ensures that we relentlessly review our processes and activities to maintain the quality and service our customers expect.

For information on how to select the most appropriate brush construction and materials for your application, see Selecting the Right Brush in this catalog. Additional information is available on our web site at [www.sealeze.com](http://www.sealeze.com). And, you can always call us to speak with a knowledgeable, experienced sales representative. See Contact Us at the back of this catalog.

# Typical Applications

## Shielding against flying debris, dust, air, spray, light, and sound

- Paint and powder booths
- Machine tools
- Woodworking machinery
- Dark rooms
- Clean rooms
- Radiology rooms



## Cleaning—heavy-duty or delicate wiping

- Wiping threads (ball screws and lead screws)
- Cleaning conveyor belts
- Guiding and cleaning hoses and wires
- Vacuum collection
- Descaling wire and rods



## Closing gaps

- Lever seals
- Overhead conveyors
- Conveyor belts
- Machine doors
- Cable management
- Raised computer room floor seals



## Static dissipation

- Web presses
- Packaging
- High-speed rolls, paper, film
- Textiles
- Electronics



## Sealing machinery from chips and debris

- Bushings/bearings
- Robotics
- Ball screws
- Linear motion/positioning
- Hydraulic rams



NOTE: For information about selecting brush appropriate for your application, see “Selecting the Right Brush”.

# Stock Nylon Filament Brushes (metal-backed construction)

Sealeze stock nylon brushes with metal-backed construction paired with our aluminum holders are ideal choices for addressing numerous applications. Our stock brushes use high-quality nylon filament and have excellent abrasion resistance, flex life, bend recovery, and springiness (often called “flicking”). These brushes have good stiffness, are resistant to set and are best used in working temperatures below 230°F.

Available immediately from our large stock, these brushes come in 8 ft. or 10 ft. lengths with Nylon 6

filament and galvanized steel channels, and are available in a variety of filament trim lengths and diameters. Custom trim lengths, filament diameters, and filament materials (metal and natural). Other channel materials are available with quick turnaround.

If our stock nylon brushes don’t meet your needs, we can manufacture strip brushes with custom trims, materials and densities. Contact a Sealeze sales representative for details. For flexible-backed brushes, see the section on Ez-Flex flexible brushes in this catalog.

## Straight Strip Brushes – Type 6.0 Nylon – Stock Lengths 8 and 10 Feet\*

\* Stock length availability may vary depending on product code.

Section	Product Code	X	Y	OAT	Exposed Length	Stock Filament	Other Available Filament Diameters
A	SFA102BL	0.095	0.110	0.37	0.22	0.006	0.004 to 0.010
	SFA104BL	0.095	0.110	0.56	0.41	0.006	0.004 to 0.010
	SFA108BL	0.095	0.110	0.90	0.75	0.006	0.004 to 0.010
	SFA110BL	0.095	0.110	1.15	1.00	0.006	0.004 to 0.010
B	SFB105BL	0.150	0.152	0.75	0.54	0.006	0.004 to 0.012
	SFB110BL	0.150	0.152	1.22	1.01	0.006	0.004 to 0.012
C	SFC106BL	0.180	0.199	0.87	0.62	0.006	0.004 to 0.016
	SFC110BL	0.180	0.199	1.28	1.03	0.006	0.004 to 0.016
D	SFD109BL	0.240	0.256	1.25	0.93	0.008	0.006 to 0.020
	SFD112BL	0.240	0.256	1.50	1.18	0.008	0.006 to 0.020
	SFD116BL	0.240	0.256	1.92	1.60	0.012	0.008 to 0.020
	SFD120BL	0.240	0.256	2.31	1.99	0.012	0.008 to 0.020
	SFD130BL	0.240	0.256	3.31	2.99	0.012	0.008 to 0.020
F	SFF115BL	0.313	0.313	1.88	1.50	0.016	0.008 to 0.035
	SFF120BL	0.313	0.313	2.38	2.00	0.016	0.008 to 0.035
	SFF125BL	0.313	0.313	2.88	2.50	0.016	0.008 to 0.035
	SFF130BL	0.313	0.313	3.38	3.00	0.020	0.008 to 0.035
	SFF140BL	0.313	0.313	4.38	4.00	0.020	0.012 to 0.035
	SFF150BL	0.313	0.313	5.38	5.00	0.020	0.012 to 0.035
	SFF160BL	0.313	0.313	6.38	6.00	0.020	0.012 to 0.035
G	SFG118BL	0.350	0.370	2.25	1.82	0.012	0.008 to 0.060
	SFG118BL	0.350	0.370	2.25	1.82	0.035	0.008 to 0.060
	SFG125BL	0.350	0.370	3.00	2.57	0.012	0.008 to 0.060
	SFG125BL	0.350	0.370	3.00	2.57	0.035	0.008 to 0.060
	SFG130BL	0.350	0.370	3.50	3.07	0.020	0.012 to 0.060
	SFG130BL	0.350	0.370	3.50	3.07	0.035	0.012 to 0.060
	SFG140BL	0.350	0.370	4.50	4.07	0.020	0.012 to 0.060
	SFG140BL	0.350	0.370	4.50	4.07	0.035	0.012 to 0.060
	SFG150BL	0.350	0.370	5.50	5.07	0.020	0.020 to 0.060
	SFG150BL	0.350	0.370	5.50	5.07	0.035	0.020 to 0.060
K	SFK130BL	0.500	0.500	3.58	3.00	0.045	0.020 to 0.060
	SFK140BL	0.500	0.500	4.58	4.00	0.045	0.020 to 0.060
	SFK150BL	0.500	0.500	5.58	5.00	0.045	0.020 to 0.060
	SFK160BL	0.500	0.500	6.58	6.00	0.060	0.020 to 0.060
	SFK170BL	0.500	0.500	7.58	7.00	0.060	0.020 to 0.060
	SFK1100BL	0.500	0.500	10.58	10.00	0.060	0.020 to 0.060
	SFK1120BL	0.500	0.500	12.58	12.00	0.060	0.020 to 0.060

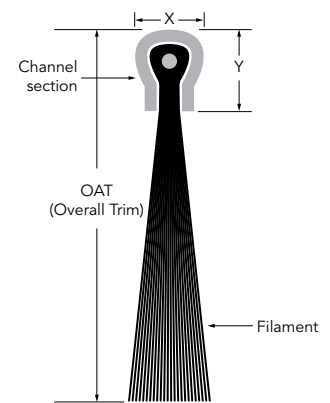

# Stock Aluminum Holders

Sealeze extruded aluminum brush holders fit our straight metal-backed and EZ-Flex® flexible strip brushes and are available in 8-ft. or 10-ft. lengths. (Lengths vary depending on section size and flange angle.) Stock aluminum brush holders have a clear anodized finish, without mounting holes.

To select the correct size, match the section letter of the brush to the section letter of the holder and then choose the flange angle needed. Brush holders can be cut to length, provided with punched holes or machined slots for easy mounting. If one of our stock flange angles does not meet your needs, the “B” dimension of the flange may be bent or trimmed to meet your requirements. Finishes include mill, clear anodized,

black anodized, gold anodized, and Duranodic (dark bronze)\*. Holders can be formed into custom shapes to match custom-formed brushes. For assistance in selecting the right holder and mounting configuration for your application, contact a Sealeze sales representative.

Sealeze edge-mount holders, made of black ABS plastic, securely hold Sealeze metal-backed strip brushes and EZ-Flex flexible strip brushes to the edge of any sheet metal 30 (0.185 in/0.318 mm) to 12 gauge (0.104 in/2.64 mm). These holders can securely mount Sealeze size C or D brushes without the need for screws, rivets, or tape.

\* Not all finishes are available for every size. Special finishes are available.

## Stock Aluminum Brush Holders

Fits Brush Section Size	Holder Product Code	X	A	B	C	D
<b>Straight Flanges</b>						
A	XTA180CLA	180°	0.040	0.446	0.212	0.197
B	XTB280CLA	180°	0.062	0.427	0.264	0.267
	XTB210CLA	180°	0.062	0.735	0.265	0.262
C	XTC380CLA	180°	0.050	0.439	0.311	0.292
	XTC381CLA	180°	0.050	0.750	0.311	0.292
	XTC382CLA	180°	0.050	1.500	0.311	0.292
	XTC383CLA	180°	0.055	3.000	0.311	0.292
D	XTD480CLA <sup>(1)</sup>	180°	0.062	0.711	0.391	0.366
	XTD482CLA	180°	0.062	1.500	0.391	0.366
	XTD483CLA	180°	0.062	3.000	0.391	0.366
F	XTF580CLA	180°	0.062	1.000	0.474	0.469
	XTF582CLA	180°	0.062	1.500	0.474	0.469
G	XTG680CLA <sup>(2)</sup>	180°	0.062	0.784	0.528	0.505
	XTG682CLA	180°	0.062	1.472	0.528	0.505
	XTG682FCLA (off-set)	180°	0.062	1.407	0.528	0.880
	XTG685CLA	180°	0.079	4.894	0.576	0.539
	XTGG680CLA (double)	180°	0.062	1.250	0.528	0.948
K	XTK1082CLA	180°	0.079	2.001	0.689	0.667
<b>Angled Flanges</b>						
A	XTJ140CLA	40°	0.062	0.750	0.225	0.213
B	XTB215CLA	15°	0.062	0.768	0.265	0.262
	XTB230CLA	30°	0.062	0.862	0.265	0.262
C	XTC345CLA	45°	0.050	1.250	0.311	0.292
D	XTD445CLA	45°	0.062	0.844	0.391	0.366
	XTD45XCLA	45°	0.062	1.890	0.391	0.366
	XTD45RCLA <sup>(3)</sup>	45°	0.062	1.000	0.391	0.366
F	XTF545CLA	45°	0.062	1.500	0.474	0.469
G	XTG645CLA	45°	0.062	1.000	0.528	0.505
<b>Right-Angled Flanges</b>						
A	XTA190CLA	90°	0.056	0.347	0.220	0.204
B	XTB290CLA	90°	0.055	0.423	0.264	0.266
	XTB292CLA	90°	0.055	1.252	0.258	0.260
C	XTC390CLA	90°	0.060	0.663	0.331	0.303
D	XTD490CLA	90°	0.062	0.697	0.391	0.365
F	XTF590CLA	90°	0.062	1.000	0.474	0.469
G	XTG690CLA	90°	0.062	0.873	0.528	0.505
K	XTK1092CLA	90°	0.079	1.751	0.688	0.667
<b>Edge Mount</b>						
C	XTCEMPBK-120	180°	N/A	0.960	N/A	0.280
D	XTDEMPBK-120	180°	N/A	0.960	N/A	0.340

<sup>(1)</sup>Also available in roll-formed stainless steel <sup>(2)</sup>Also available in polypropylene and roll-formed stainless steel <sup>(3)</sup>Reverse Flange

All dimensions in inches, unless otherwise indicated. Dimensions are to Sealeze manufacturing tolerances. Contact us for more information on tolerances.

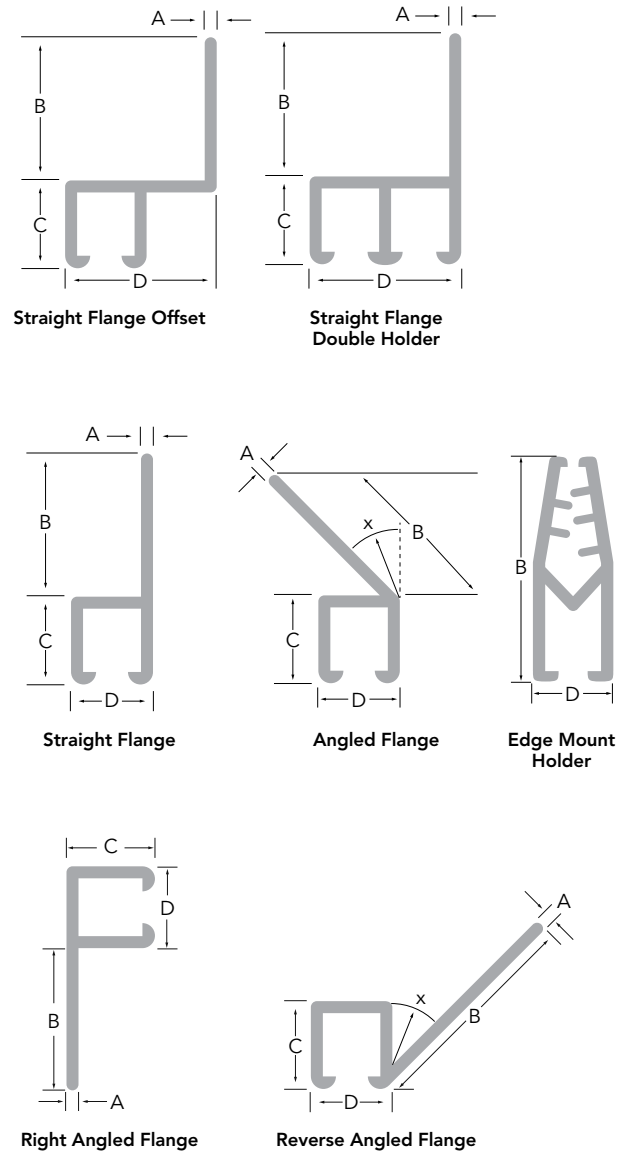

# Static Control Brushes

## Static Brushes

Our static control brushes are for applications requiring electrical conductivity, static dissipation, or EMI shielding properties. Some of these brushes are available for use in FDA controlled environments. Ask your Sealeze representative for details.

**Static dissipative nylon filament brushes\*** are made with carbon particles chemically bonded to nylon filaments providing excellent strength and flexibility in working temperatures up to 230 degrees F. (These brushes are not recommended for use with un-encapsulated electronic microcircuits.) Static-dissipative brushes are available in mixtures of 20% or 100% conductive filament to meet your application needs. Sealeze conductive filaments have an electrical resistance of 20,000 ohms per inch (depending upon filament diameter) for excellent electrical conductivity.

**Anti-static nylon filament brushes\*** are made with nylon filaments that are permanently infused throughout with a conductive agent that does not affect the mechanical or physical properties of the filament. Surface resistivity is  $1 \times 10^9$  ohms. Best used in applications where static generation is not desired.



## Soft-Fiber Brushes

**Sealeze soft-fiber, static-dissipative brushes\*** are designed for applications requiring the gentlest touch. Made from Thunderon® fiber, these brushes can be installed in any Sealeze size G aluminum, roll-formed steel or stainless steel brush holders. Thunderon is an acrylic fiber that has been chemically bonded with a layer of copper sulfide to produce a resistance of 3 to 5 times  $10^{-4}$  ohms per centimeter. These brushes are manufactured with tufts spaced 0.25 of an inch apart with exposed fiber length of 1.50 inches. We can trim to shorter fiber lengths to meet your needs.

## Metal Filament & Horse Hair

Metal Filament brushes are used to dissipate static charges in applications where brush properties such as high-abrasion or resistance to elevated temperatures are required.

Horse hair is static neutral and resists the generation of static electricity. Horse hair filament is often used in printing and other applications where the generation of static electricity on the brush or surface the brush touches is not wanted. Horse hair is not conductive; it will not dissipate or remove static electricity from a surface or object.

Visit our website at [sealeze.com](http://sealeze.com). We offer several data sheets and white papers that can be downloaded in PDF format.

**NOTE:** Static dissipative and anti-static brushes must be grounded for maximum effectiveness. Grounding is best achieved when grounding screw touches channel section.

Product Code	X	Y	OAT	Filament Diameter	Filament Type
<b>Static Seal Dissipative</b>					
SFB115BL20CF	0.150	0.152	1.72	0.010	20% Conductive/ 80% Nylon
SFB115BL100CF	0.150	0.152	1.72	0.010	100% Conductive Fiber
SFC130BL20CF	0.180	0.199	3.25	0.010	20% Conductive/80% Nylon
SFC130BL100CF	0.180	0.199	3.25	0.010	100% Conductive Fiber
SFD130BL20CF	0.240	0.256	3.30	0.010	20% Conductive/80% Nylon
SFD130BL100CF	0.240	0.256	3.30	0.010	100% Conductive Fiber
<b>Soft Fiber Thunderon</b>					
SSG515AT1D	0.35	0.40	1.85	0.0015	0.5 Tuft Spacing
<b>Static Seal Anti-Static</b>					
Consult your Sealeze representative				Infused conductive agent	

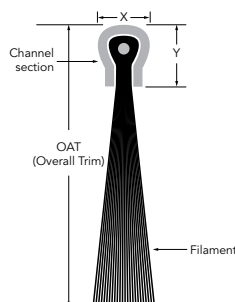

\*Product data sheets are available for static control brushes at [sealeze.com](http://sealeze.com) or contact your Sealeze sales representative.

# Formed Brushes

Sealeze standard formed brushes include coils, spirals, cups, arcs and custom shapes and trim. Channel sizes include A, B, C, D, F, G, and K and are available in galvanized and stainless steels. A wide range of synthetic, natural and metal filaments are available. Products made within the dimensions shown are manufactured with our standard tooling and stocked materials. For formed products constructed with K channel, consult your Sealeze sales representative for minimum and maximum dimensions. If you require IDs or ODs that are outside these standard sizes, let us know. We specialize in “pushing the limits” for both large and small diameters. What others can’t do, we do every day!

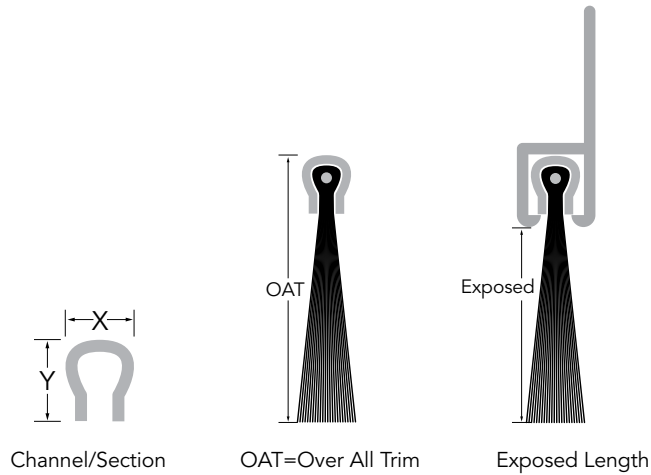

## Channel Section Size

Section Size	(X) Width	(Y) Height
A	0.095	0.110
B	0.150	0.152
C	0.180	0.199
D	0.240	0.256
F	0.313	0.313
G	0.350	0.370
K	0.500	0.500

## How to Order Formed Brushes

This section provides information on Sealeze formed brushes. Diagrams (on the following pages) show critical dimensions, such as ID (inside diameter), OD (outside diameter), IR (inside radius), etc. and points at which these dimensions are measured. Please refer to these diagrams when completing worksheets or when talking to a Sealeze representative. (Be sure to identify which, if any, of these dimensions are critical in your application.)

### Depending on the formed brush product you need, the following information may be necessary:

- Quantity Required
- Inverted Spirals: OD, ID, WD, overall length and pitch
- External Arcs: IR, OR, degrees of arc
- Inverted Coils: OD and ID
- External Spirals: ID, OD, WD, face length, pitch, mandrel – if required
- Cup Seals: OD, ID, OAT
- External Coils: ID and OD
- Inverted Arcs: OR, IR, degrees of arc
- Cup Arcs: OR, IR, OAT, degrees of arc

ID = inside diameter  
 OD = outside diameter  
 IR = inside radius  
 OR = outside radius  
 OAT = overall trim length  
 WD = wind direction (left or right)  
 Pitch = the distance from the center of one turn to the center of the next turn.

### Special shape, small quantity or prototype?

If you are a design engineer in need of small quantities, prototype production, or “non-standard” forms or shapes—let us help. Send us your requirements and concept drawings. We specialize in rapid turn-around, small quantity and prototype production. When you’re ready for larger production quantities, we don’t make you order thousands or make you wait to “fit you into our production schedule.”

### Please complete a worksheet

Please take a few minutes to fill out the appropriate worksheet. Completing a worksheet ensures accuracy regarding formed brush requirements. Worksheets are available for the formed brushes listed in this section. To obtain a worksheet for any of these products, phone us at 800.787.7325 or visit our web site at [sealeze.com](http://sealeze.com) to download a worksheet in PDF format. For your convenience, many of our worksheets can also be completed on-line.



# Cup Forms

Cup seals and cup arcs are available with and without brush holders, or can be installed with mounting tabs. (See Mounting Tabs section).

The minimum dimensions (OD, ID, OR, IR) for these forms may vary based on choice of filament and filament diameter.

## Cup Seals



Minimum OD for Cup Seals

Section	Product Code*	Galvanized Channel	Stainless Channel
A	CFA1	1.000	1.500
B	CFB1	1.250	1.750
C	CFC1	1.500	2.000
D	CFD1	2.000	3.000
F	CFF1	2.750	3.625
G	CFG1	3.000	4.000
K	CFK1	10.000	12.000

## Cup Arcs



Minimum OR for Cup Arcs

Section	Product Code*	Galvanized Channel	Stainless Channel
A	CAA1	0.500	0.750
B	CAB1	0.625	0.875
C	CAC1	0.750	1.000
D	CAD1	1.000	1.500
F	CAF1	1.375	1.813
G	CAG1	1.500	2.000
K	CAK1	5.000	6.000



Minimum OD for Cup Seals with Formed Aluminum Holders

Section	Product Code*	Straight Flange		Right Angle Flange		Angled Holder
		Interior	Exterior	Interior	Exterior	
A	CFA1	4.000	4.000	7.000	6.000	On Application
B	CFB1	6.000	5.000	9.000	7.000	On Application
C	CFC1	7.000	6.000	12.000	8.000	On Application
D	CFD1	7.500	6.500	On Application	9.000	On Application
F	CFF1	On Application		On Application		On Application
G	CFG1	12.000	10.000	On Application	12.000	On Application



Minimum OR for Cup Arcs with Formed Aluminum Holders

Section	Product Code*	Straight Flange	Right Angle Flange	Angled Holders
A	CAA1	2.000	3.000	On Application
B	CAB1	2.500	3.500	On Application
C	CAC1	3.000	4.000	On Application
D	CAD1	3.250	4.500	On Application
F	CAF1	On Application		On Application
G	CAG1	6.000	6.000	On Application

Note; The photo above shows a cup seal with box channel of the formed holder rolled to the outside. The "exterior" measurement for OD is for holders formed as shown, with the box channel on the outside. "Interior" OD is for holders with the box channel on the inside.

\* 304 S/S Channel change "1" to "2." Other S/S available on request.

All dimensions in inches, unless otherwise indicated. Dimensions are to Sealeze manufacturing tolerances. Contact us for more information on tolerances.

# Arc Forms

Inverted arcs (filaments pointed inward) and external arcs (filaments pointed outward) are available with and without brush holders. Mounting tabs are also available. (See Mounting Tabs section).

The minimum dimensions (OD, ID, OR, IR) for these forms may vary based on choice of filament and diameter.

## Inverted Arcs



Minimum OR for Inverted Arcs

Section	Product Code*	Galvanized Channel	Stainless Channel
A	IAA1	0.313	0.500
B	IAB1	0.656	1.250
C	IAC1	1.094	1.875
D	IAD1	1.425	2.125
F	IAF1	1.750	2.625
G	IAG1	2.000	3.000
K	IAK1	4.000	On Application

## External Arcs



Minimum IR for External Arcs

Section	Product Code*	Galvanized Channel	Stainless Channel
A	EAA1	0.375	0.750
B	EAB1	0.500	1.000
C	EAC1	0.625	1.125
D	EAD1	0.750	1.250
F	EAF1	0.900	1.400
G	EAG1	1.000	1.500
K	EAK1	2.000	2.750

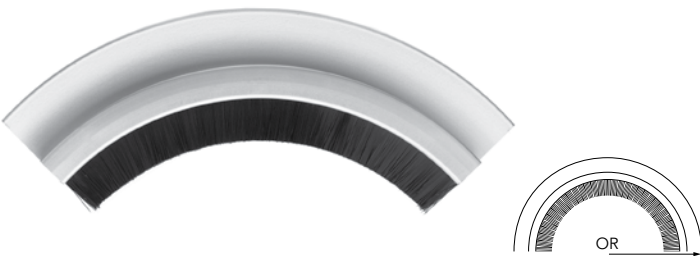

Minimum OR for Inverted Arcs with Formed Aluminum Holders

Section	Product Code*	Straight Flange	Right-Angle Flange	Angled Holders
A	IAA1	2.500	2.000	On Application
B	IAB1	3.000	2.500	On Application
C	IAC1	3.500	3.000	On Application
D	IAD1	3.750	3.250	On Application
F	IAF1	On Application	On Application	On Application
G	IAG1	5.000	4.000	On Application



Minimum IR for External Arcs with Formed Aluminum Holder

Section	Product Code*	Straight Flange	Right-Angle Flange	Angled Holders
A	EAA1	2.500	2.000	On Application
B	EAB1	3.000	2.500	On Application
C	EAC1	3.500	3.000	On Application
D	EAD1	3.750	3.250	On Application
F	EAF1	On Application	On Application	On Application
G	EAG1	5.000	4.000	On Application

\* 304 S/S Channel change "1" to "2." Other S/S available on request.  
 All dimensions in inches, unless otherwise indicated.  
 Dimensions are to Sealeze manufacturing tolerances. Contact us for more information on tolerances.

# Coil Forms

Inverted and external coils are available in a wide range of synthetic, natural and metal filaments, with and without brush holders, or can be installed with mounting tabs. (See Mounting Tabs section). Inverted coils can be mounted in machined retaining rings. The minimum dimensions (OD, ID, OR, IR) for these forms may vary based on choice of filament and filament diameter.

## Inverted Coil

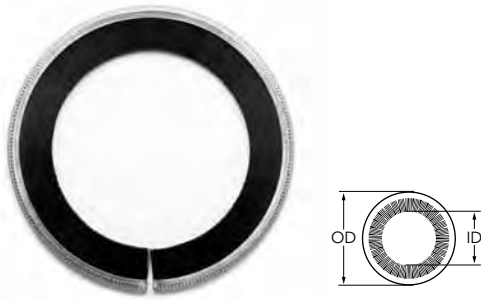

### Minimum OD for Inverted Coils

Section	Product Code*	Galvanized Channel	Stainless Channel
A	ICA1	0.625	1.000
B	ICB1	1.312	2.500
C	ICC1	2.187	3.750
D	ICD1	2.850	4.250
F	ICF1	3.500	5.250
G	ICG1	4.000	6.000
K	ICK1	8.000	On Application

## Inverted Coil with Aluminum Holder

(split-ring shaft seal, 2 180° arcs)

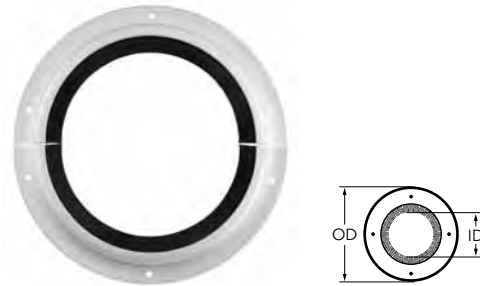

### Minimum OD for Inverted Coils with Formed Aluminium Holders

Section	Product Code*	Straight Flange <sup>1</sup>	Right-Angle Flange <sup>2</sup>	Angled Holders
A	ICA1	5.000	4.000	On Application
B	ICB1	6.000	5.000	On Application
C	ICC1	7.000	6.000	On Application
D	ICD1	7.500	6.500	On Application
F	ICF1	On Application		On Application
G	ICG1	10.000	8.000	On Application

1. Two-piece holder (2, 180° arcs) 2. Four-piece holder (4, 90° arcs)

## Inverted Coil with Machined Retaining Ring

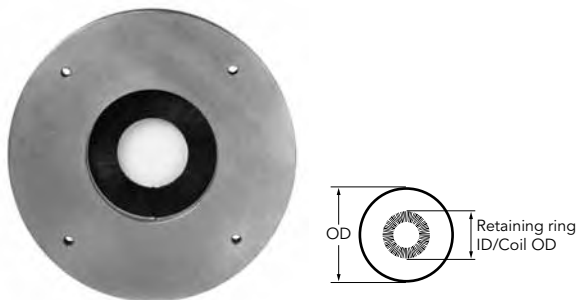

### Minimum OD for Inverted Coil

Section	Product Code*	Galvanized Channel	Stainless Channel
A	ICA1	0.625	1.000
B	ICB1	1.312	2.500
C	ICC1	2.187	3.750
D	ICD1	2.850	4.250
F	ICF1	3.500	5.250
G	ICG1	4.000	6.000

## External Coil

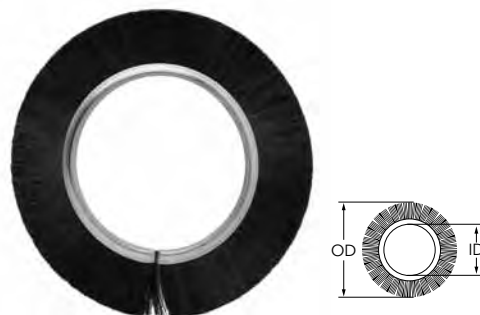

### Minimum ID for External Coils

Section	Product Code*	Galvanized Channel	Stainless Channel
A	ECA1	0.750	1.000
B	ECB1	1.000	1.500
C	ECC1	1.250	2.250
D	ECD1	1.500	2.500
F	ECF1	1.800	2.800
G	ECG1	2.000	3.000
K	ECK1	4.000	5.500

\* 304 S/S Channel change "1" to "2." Other S/S available on request.

All dimensions in inches, unless otherwise indicated. Dimensions are to Sealeze manufacturing tolerances. Contact us for more information on tolerances.

# Spiral Forms

Inverted and external spirals are available both right-hand and left-hand wound, in a variety of synthetic (including conductive), metal, and natural filaments and in a full range of pitches. Mandrels for external spiral brushes can be made to your specifications—including solid or tubular construction, keyway or threaded mounting, or welded to the brush. When specifying pitch, consult a Sealeze representative for minimum spiral ID. The minimum dimensions (OD, ID, OR, IR) for these forms may vary based on choice of filament and filament diameter.

## External Spiral



Minimum ID for External Spirals

Section	Product Code*	Galvanized Channel	Stainless Channel
A	ESA1	0.188	0.500
B	ESB1	0.250	0.750
C	ESC1	0.500	1.000
D	ESD1	0.750	1.250
F	ESF1	1.000	1.500
G	ESG1	1.000	1.750
K	ESK1	1.500	5.500

## Inverted Spiral (left-hand wind direction shown, right available)

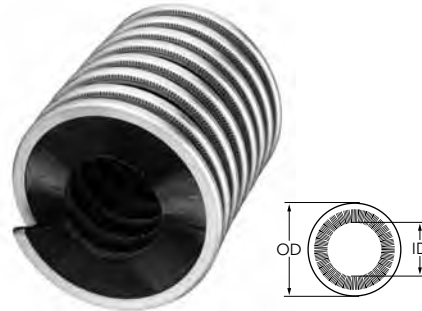

Minimum OD for Inverted Spirals

Section	Product Code*	Galvanized Channel	Stainless Channel
A	ISA1	0.625	1.000
B	ISB1	1.312	2.500
C	ISC1	2.187	3.750
D	ISD1	2.850	4.250
F	ISF1	3.500	5.250
G	ISG1	4.000	6.000
K	ISK1	8.000	On Application

# Mounting Tabs

Mounting tabs are ideal for mounting inverted coils and cup seals when formed holders are not possible. Sealeze aluminum brush holders are cut into tab lengths of 0.5 or 0.375 inches and are available with or without mounting holes. Straight, angled, and right angle flange tabs are available for each channel size as shown in the following tables.

### Straight Flange

Section	Angle	A	B	C	D
A	180°	0.040	0.446	0.212	0.197
	180°	0.062	0.735	0.265	0.262
	180°	0.050	0.439	0.311	0.292
C	180°	0.050	0.750	0.311	0.292
	180°	0.050	1.500	0.311	0.292
	180°	0.055	3.000	0.311	0.292
D	180°	0.062	0.711	0.391	0.366
	180°	0.062	3.000	0.391	0.366
	180°	0.062	1.000	0.474	0.469
F	180°	0.062	1.500	0.474	0.469
	180°	0.062	0.784	0.528	0.505
	180°	0.062	1.472	0.528	0.505
G	180°	0.079	4.894	0.576	0.539
	180°	0.079	2.001	0.689	0.667



### Angled Flange

Section	Angle	A	B	C	D
A	40°	0.062	0.750	0.225	0.213
B	15°	0.062	0.768	0.265	0.262
	30°	0.062	0.862	0.265	0.262
C	45°	0.050	1.250	0.311	0.292
D	45°	0.062	0.844	0.391	0.366
	45°	0.062	1.890	0.391	0.366
F	45°	0.062	1.000	0.391	0.366
	45°	0.062	1.500	0.474	0.469
G	45°	0.062	1.000	0.528	0.505

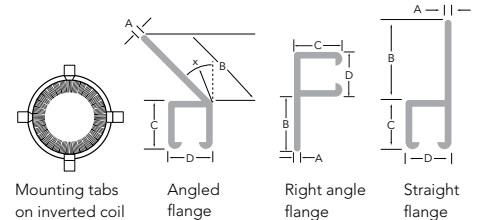

### Right Angle Flange

Section	Angle	A	B	C	D
A	90°	0.056	0.347	0.220	0.204
B	90°	0.055	0.423	0.264	0.266
	90°	0.055	1.250	0.258	0.260
C	90°	0.060	0.663	0.331	0.303
D	90°	0.062	0.697	0.391	0.365
F	90°	0.062	1.000	0.474	0.469
G	90°	0.062	0.873	0.528	0.505
K	90°	0.079	1.751	0.688	0.667

\* 304 S/S Channel change "1" to "2." Other S/S available on request.  
 All dimensions in inches, unless otherwise indicated.  
 Dimensions are to Sealeze manufacturing tolerances. Contact us for more information on tolerances.

# Specialty Strip Brush Products

Sealeze manufactures and stocks a range of specialty brushes for various applications and working environments. Many of the brushes described in this section can be formed into many of the products described in the Formed Brush section of this catalog. In addition, these brushes can be custom formed into shapes and filament trims to meet your specific application requirements.

## Metal Filament Brushes



Brushes with brass and stainless steel filament

Sealeze manufactures the highest-quality metal brushes with the widest selection of channel sizes. Our selection assures you the best size and density brush for your application. Sealeze metal filament brushes are available with mild steel, stainless steel, brass, and phosphor bronze filaments and are constructed with galvanized steel or stainless steel channel materials. Roll-formed stainless steel holders and anodized aluminum holders are available. We can also provide brushes and holders in exotic materials such as monel, inconel and specialty brass. Contact your Sealeze sales representative to discuss your application.

### Standard Filaments:

- Stainless steels (304 and 316)
- Brass
- Brass-coated steel
- Mild steel
- Phosphor bronze

### Standard Filament Diameters\*:

- 0.004
- 0.005
- 0.008
- 0.010
- 0.012

### Standard Channel Materials:

- Stainless steel (304 and 316)
- Galvanized steel

### Standard Channel Sizes:

- A
- B
- C
- D
- F
- G
- K

### Metal Filament Brush Channel/ Section Size

Section	X	Y	Min. OAT	Max. OAT	Minimum/Maximum Filament Diameters
A	0.095	0.110	0.375	3.000	0.004 to 0.010
B	0.150	0.152	0.375	4.000	0.004 to 0.012
C	0.180	0.199	0.527	5.000	0.004 to 0.012
D	0.240	0.256	0.500	6.250	0.006 to 0.012
F	0.313	0.313	0.600	6.250	0.008 to 0.012
G	0.350	0.370	0.750	6.250	0.008 to 0.012
K	0.500	0.500	On Application	On Application	0.010 to 0.012

### Stock Roll Formed Stainless Steel Holders

Fits Brush Section Size	Product Code	A	B	C	D
D	XTD480T304	0.072	0.710	0.400	0.340
G	XTG680T304	0.072	0.800	0.550	0.470

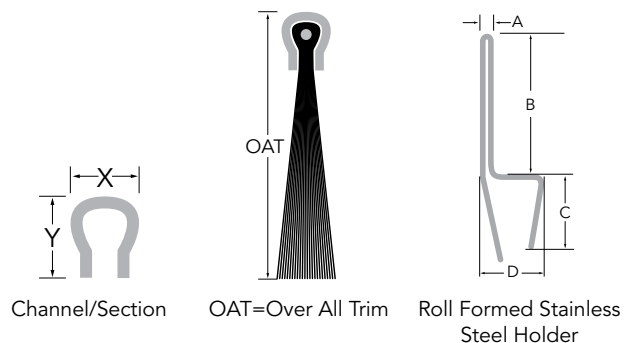

\* Not all filament diameters are available in every filament material.

All dimensions in inches, unless otherwise indicated. Dimensions are to Sealeze manufacturing tolerances. Contact us for more information on tolerances.

# Specialty Strip Brush Products

## Wire Descaling and Cleaning Brushes



Ideal for mechanical removal of scale, filings and excess coatings on rods, wires and cables, inverted brush spirals are available in a wide variety of metal and synthetic filaments. They optimize the condition of the wire surface to improve uniform lubricant adhesion, extend die life, drawing and bending machine performance, enhance traditional mechanical descaling processes, and can reduce the costs associated with chemical descaling. Sealeze offers the widest range of sizes and custom inside diameters and lengths to meet your specific application needs. Our stock and custom-made brushes are available with short lead times.

**Brass Coated Steel Filament** with galvanized steel channel for removing scale, lubrication residue and carrier coating on wires and rods.

*Available in 2.25in. and 3 in. diameter, 1 meter in length.*

**Stainless Steel Filament** with stainless steel channel for gentle scouring and high-temperature environments.

*Available in 1.00 in. and 1.25 in. diameter, 1 meter in length.*

**White Polypropylene Filament** with stainless steel channel for secondary cleaning of small diameter wire in alkaline, acid or petroleum cleaning baths.

*Available in 2.25 in. diameter, 1 meter in length.*

**Black Nylon Filament** with galvanized steel channel for removing light scale and light coatings.

*Available in 2.25 in. diameter, 1 meter in length.*

**Feather-Touch Nylon Filament** with galvanized steel channel for removing talc from copper wire.

*Available in 2.25 in. diameter, 1 meter in length.*

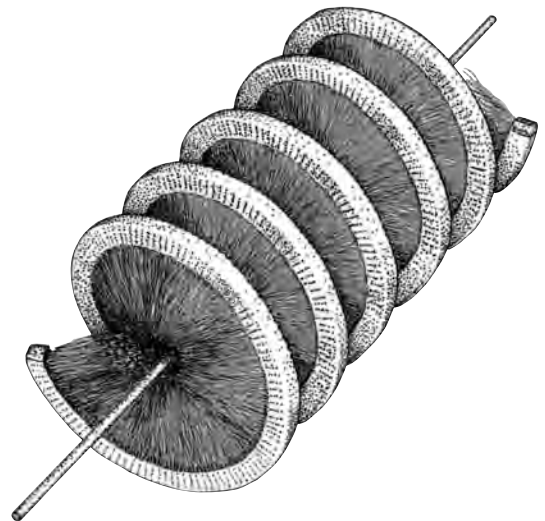

# Specialty Strip Brush Products

## Flexible Strip Brushes



Flexible strip brush



Flexible strip brush with integrated holder

The non-metal construction of Sealeze's Ez-Flex® flexible strip brush provides flexibility, increasing design options and reducing weight in weight-critical applications as compared to metal-backed strip brushes. Flex brush is constructed with high-quality nylon filaments incorporated into a continuous channel of the same material. Available in a range of filament diameters and lengths, flex brush is manufactured in a continuous process so it can be made in virtually unlimited lengths to span long distances or can be stored in rolls and "cut-to-size" with simple hand tools at your site. Flexible strip brush fits in our stock holders and is available with a molded integrated holder.

Designers who capitalize on the flexibility flex brush brings to design projects can explore possibilities not feasible with typical strip brush products. See charts below for available lengths and filament diameters. Other filament diameters and trim lengths are available. Minimum order quantities may apply. Contact a Sealeze representative to discuss your application.

### Flexible Strip Brush

Section	Product Code	Standard Filament Diameter	X*	Y*	OAT ±0.015	Standard Continuous Length (feet)
C	FXC106BL	0.006	0.180	0.200	0.87	100
	FXC110BL	0.006	0.180	0.200	1.28	100
D	FXD109BL	0.008	0.230	0.245	1.25	100
	FXD112BL	0.008	0.230	0.245	1.50	100
	FXD116BL	0.012	0.230	0.245	1.92	100
	FXD120BL	0.012	0.230	0.245	2.31	100
	FXD130BL	0.012	0.230	0.245	3.31	100

Note: Ez-Flex can be made of polypropylene for orders of 1000 feet or more. (Polypro not available with integrated holder.)

### Flexible Strip Brush with Integrated Holder

Section	Product Code	Standard Filament Diameter	X*	Y*	Flange Thickness ±0.02	Flange Height ±0.05	Exposed‡ ± 0.015	Standard Continuous Length (feet)
C	FXC80IH10BL	0.006	0.18	0.19	0.06	0.50	1.03	10
D	FXD80IH16BL	0.012	0.22	0.25	0.06	0.55	1.60	10
	FXD80IH30BL	0.012	0.22	0.25	0.06	0.55	2.99	10

Note: Ez-Flex flexible brush is an extruded product and as such, greater variance occurs in the X and Y dimensions than is experienced with metal-backed brush.

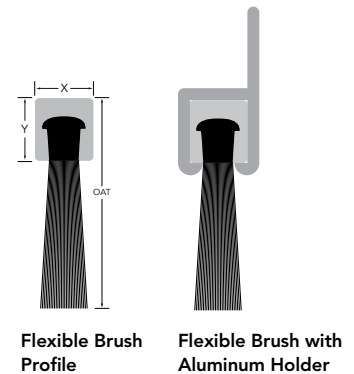

Flexible Brush Profile

Flexible Brush with Aluminum Holder

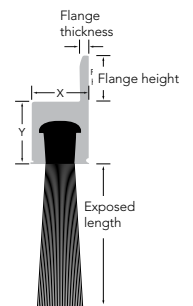

Flexible Brush with Integrated Holder

\* Tolerance for C & D sections, ± 0.02 inches.

‡ Exposed filament from bottom of integrated holder (filament length)

# Specialty Strip Brush Products

## Lever Seals

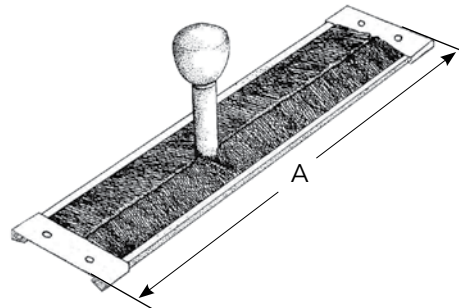

Lever seals are available in a variety of filaments and can be constructed in channel and clip materials to meet your needs. They can be made to almost any length and width.

Lever seals are ideal for sealing gaps where it is necessary to maintain a seal yet allow movement of an object along the gap. For example, lever seals are used to seal the gaps levers traverse in machinery control panels and are used to seal cable entrances on electronic equipment and manage cables in technical furniture applications.

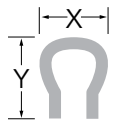

### Channel/Section

Section	X	Y
A	0.095	0.110
B	0.150	0.152
C	0.180	0.199
D	0.240	0.256
F	0.313	0.313
G	0.350	0.370
K	0.500	0.500

### Stock Lever Seal Assemblies

Part Number	Description
<b>LSB103BC</b>	304 stainless steel clips (2); SFB103BC stock nylon brush (cut to length "A") with 0.500 OAT, nylon black crimped filament, galvanized steel channel- assembled.
<b>LSC110BC</b>	304 stainless steel clips (2); SFC110BC stock nylon brush (cut to length "A") with 1.20" OAT, nylon black crimped filament, galvanized steel channel- assembled.
<b>LSD112BC</b>	304 stainless steel clips (2); SFD112BC stock nylon brush (cut to length "A") with 1.50 inches OAT, nylon black crimped filament, galvanized steel channel- assembled.

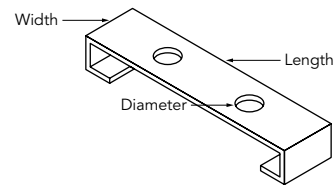

### Stock 304 Stainless Steel Clip Specifications for Stock Lever Seals

Fits Brush Channel	Length	Width	Hole Diameter	Hole Spacing
<b>B</b>	1.06	.316	.138	.340
<b>C</b>	2.46	.315	.138	.807
<b>D</b>	3.06	.500	.190	1.236

## CoolBalance®– for Data Center Cable Management



A brush configuration similar to a lever seal can be used to seal the cable openings in raised-floors in data centers and server rooms. Sealeze has developed a complete line of CoolBalance products for these applications, including products for in-floor and surface mounting as well as through-wall applications. For more information on these products, please visit our CoolBalance website at [www.coolbalance.biz](http://www.coolbalance.biz).



# Specialty Strip Brush Products

## Rotary Brushes

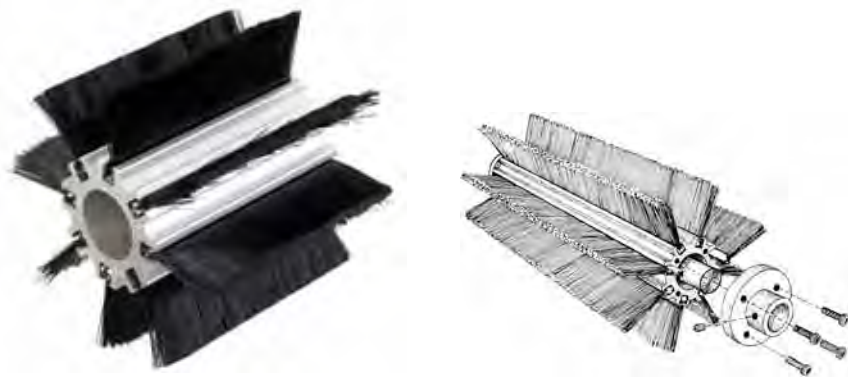

Custom rotary strip brushes are available in two sizes: D Series and G Series. Extrusions are made from aluminum alloy. Machined aluminum alloy mounting hubs are stocked. Hubs for D Series rotary brushes mount on shafts with 0.750 inch diameter; hubs for G Series rotary brushes mount on shafts with 1.000 inch diameter. Brush channel materials include galvanized steel and a variety of stainless steels. A variety of filament materials is available (including crimped and level) with a wide selection of filament diameters. Custom mandrels and hubs can be designed and manufactured. Face-lengths up to 120 inches are available. A minimum face length rotary holder of 3 inches is required with mounting hubs.

These rotary brushes are ideal for light cleaning and product positioning applications with 120 RPM or less. Brushes can be provided with filament length to meet your specific requirements and worn brushes are easily replaced by removing one of the hub ends.

## XtraSeal® Brushes



XtraSeal® brushes are ideal for heavy-duty sealing applications where an impervious, yet flexible, shield is required. Sandwiched between layers of filament, a solid sheet of thin, flexible material (membrane) provides a barrier to debris and sprays. This is ideal for tough applications where debris or jets of fluid need to be contained.

XtraSeal brushes can be provided with membrane lengths to your specification. Typically, the membrane is 0.250 of an inch shorter than the brush filaments to maintain the sweep effect of the brush. XtraSeal brushes are available in all channel sizes, with galvanized steel and stainless steel channel materials. Filament materials include nylon and polypropylene (level and crimped) in a full range of diameters. Barrier materials include: EPDM (not available for size A), polyethylene, polypropylene, and others.

# Specialty Strip Brush Products

## Natural Fiber Brushes



Sealeze manufactures brushes using tampico and horsehair filament for applications where synthetic filaments are not suitable. Tampico is resistant to heat and chemicals, medium-soft in texture, highly water absorbent and most often used for light scrubbing, washing and light-abrasive applications. Horsehair is relatively soft to moderately stiff, depending on bristle length and grade. Horsehair is used dry for polishing or scratch-free cleaning on delicate surfaces or as filament that resists generation of static electricity. Natural fiber brushes, whether made from animal hair or plant based materials, will vary in color.

## Punching Options



Brush holders can be straight or formed and provided with mounting holes in a wide variety of standard shapes and sizes. Holes can be located to your specific requirements. Custom sizes, shapes and notches can be provided as required.

For applications where tolerances are critical we offer milling services. For assistance in selecting the right holder and mounting configuration for your application, contact a Sealeze sales representative.

Standard punch shapes including:

- Obround
- Round
- Square
- Rectangular

# Specialty Strip Brush Products

## Elevated Temperature Brushes



### 300° F or Lower

Our synthetic brushes for elevated temperature applications have excellent abrasion resistance, flex life, bend recovery and solvent resistance. They are designed for working temperatures up to 300°F. Brushes listed below are available from stock, are assembled with straight or angled clear anodized aluminum holders and come in 8 ft. or 10 ft. lengths.

UL rating is for Gasketing Materials for Fire Door Applications, 3-hour rating.

Larger channel sizes and other filament diameters are available.

Product Code	Flange	Exposed Filament Length	Filament Diameter
B210CLA05AZ	Straight	0.500	0.008
B210CLA10AZ	Straight	1.000	0.008
B215CLA05AZ	15 Degree Angle	0.500	0.008
B215CLA10AZ	15 Degree Angle	1.000	0.008
B230CLA05AZ	30 Degree Angle	0.500	0.008
B230CLA10AZ	30 Degree Angle	1.000	0.008

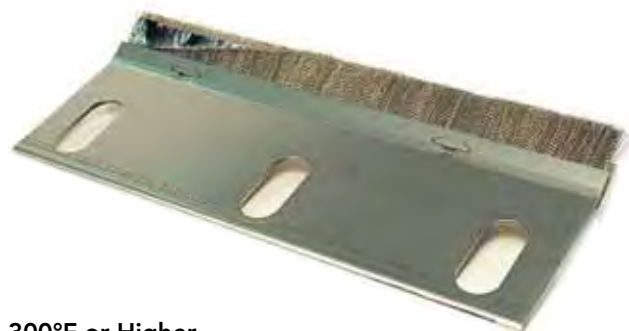

### 300°F or Higher

Consider metal filament brushes. Our wide variety of metal filament materials and diameters meet most application requirements.

Sealeze's all stainless steel brush construction is ideal for low pressure sealing applications with temperatures up to 700°F. Stainless steel filaments nest closely together providing an effective seal for gaps between irregular surfaces while allowing adjacent surfaces to move independently.

For enhanced sealing, XtraSeal® brush, consisting of a solid piece of thin, flexible stainless steel sandwiched between layers of filament, provides a seal that increases the effectiveness of the brush by as much as 80%.

# Customizing Brush to Your Needs



In addition to manufacturing straight strip brushes with exposed filament lengths of 0.125 inches and greater, we can manufacture brushes with special profile trims. We can die-cut filament profiles to your drawings to provide a brush that will seal or wipe an irregular shape or surface. Filaments are available with diameters of 0.003 inches and larger, in almost any color you might need. Minimum orders may apply for special filament colors, shapes, etc.

Our stock brush channels are galvanized steel and immediately available. We stock stainless steel materials and can provide stainless steel channel brushes in 5 to 10 working days. We have the capability to make brushes with brass and monel channels and will consider other channel materials upon request. Longer lead times and minimum orders may apply.

A variety of standard hole punch sizes and shapes are available to meet your mounting needs. Ask your Sealeze sales representative or go to our web site for a complete list of these punch sizes and shapes. If our standard sizes and shapes don't meet your needs, we can provide mounting holes to your exact dimensions and placement. We can machine-notch the flange to perfectly fit your application and holders can be anodized to your specifications or powder coated to any color. All of our extruded holders are aluminum; roll-formed holders in alloys such as steel, stainless steel, brass and monel are available.

Our in-house engineers are available to help you identify the exact filament and physical requirements for your application. We can work with your engineers to provide custom-formed inverted and external coils, external and inverted spirals, cups, arcs and custom shapes and trim length.

- Machined and formed brushes and holders to your engineering drawings
- Widest Variety of Brush and Holder Materials
- Anodizing and Powder Coating Holders in Any Color
- Assembly and Punching
- Prototyping
- R&D and Consulting— our experienced in-house engineers are here to assist you
- Technical Data Sheets
- FREE Straight Brush Samples— 4 inch piece, for brush property evaluation

# Staple Set Brushes

Staple set brushes\* (also known as punch or tufted brushes) provide an extensive range of design options. Brushes can be designed with a variety of substrate materials and filament types in different shapes, lengths, and diameters to meet the requirements of a specific application. Sealeze offers a range of filament materials in order to provide the best performance and value. Filaments can be combined or angled with special trim profiles to enhance the brushing action. Substrates can also be customized for easy installation using different materials, including wood and synthetic materials (i.e. UHMW, HDPE, Acetal, Polypropylene).

## Radial Brushes



Radial brushes (also referred to as wheel, rotary, or cylinder brushes) can be mounted horizontally or vertically. Best used in transporting and cleaning applications, they are also used for applying solutions and wiping labels. Brush patterns may be designed to provide directional movement of products.

OD range - 1 inch to 14 inches

Lengths - up to 39 inches

500 RPM, maximum - based on substrate and brush design

## Strip Brushes



Strip brushes, used for guiding, sealing, positioning, and shielding, are long and narrow. The substrates can be customized to include mounting features, making separate holders unnecessary in some applications. They can also be designed as inserts for permanent holders, reducing replacement costs. For material handling applications, flexible substrates such as conveyor belting can be specified.

Lengths - unlimited

Widths - up to 12 inches

## Lag Brushes



Lag brushes (or block brushes) are generally identified by a wide brushing area. Typically they are mounted in a stationary position for shielding, guiding or positioning products as well as hand cleaning applications. By varying the face density (brush pattern), lag brushes can also convey product without damaging product surfaces.

Lengths - up to 39 inches

Widths - up to 4 inches

## Disc Brushes



Disc brushes are recommended for cleaning, polishing, and finishing applications. As with all Sealeze staple set brushes, the brush pattern can be designed for a range of light duty to heavy duty functions.

OD range - up to 20 inches

\* All information is provided as general reference. Other specifications or materials may be available depending on application and brush design.

# Staple Set Brushes

## Modular Brushes



Modular brushes are used for general cleaning, transporting and in applications with varying levels of movement. Basically, they are radial brushes with substrates designed to interlock allowing individual segments† to be replaced as needed. Seams between brushes are prevented through the specially designed connections. Different sizes can be combined to fit specific applications, large or small.

OD range - 3 inches to 14 inches

Segment length - 4 inches

500 RPM, maximum - depending on selected body size

† Contact a Sealeze representative regarding additional specifications

## Head Brushes



Head brushes (also called dome or goblet brushes) provide brushing action on multiple surfaces. These brushes are generally used for cleaning, polishing, and lubricating the ID's of cylinder bores and tubes, or any internal curved surfaces.

OD range - up to 4 inches

Heights - up to 8 inches

## General guidelines for choosing staple set brush for your application\*

- Tuft diameters - 1/8, 5/32, 7/32, 1/4, and 5/16 of an inch
- Exposed filament length - up to 6 inches depending on filament and brush design
- Flare angle - up to 60 degrees depending on brush design
- Staple wire - galvanized and corrosion-free

<b>Cylinder (Radial and Modular)</b>	Designed for cleaning, transporting, conveyor belts and coiled products, the rotational movement provides brushing action, frequently used for "directional" movement of materials
<b>Lag (Block or Plate)</b>	Designed for general positioning or guiding; can support significant loads for maximum conveying properties while protecting the surface finish; yields good performance in shielding, filtering, and moderate sealing
<b>Strip</b>	Typically used for "long and narrow" applications such as guiding, shielding or filtering; can be assembled in tandem to create larger designs configured for material conveying
<b>Disc</b>	Generally used for surface finishing and polishing of flat surfaces
<b>Head (Goblet)</b>	Specialized design for use on unusual cylindrical surfaces (interior or exterior); can be designed to conform to specific surface dimensions to achieve maximum performance results

\* All information is provided as general reference. Other specifications or materials may be available depending on application and brush design.

All dimensions in inches, unless otherwise indicated.  
Dimensions are to Sealeze manufacturing tolerances. Contact us for more information on tolerances.

# Selecting the Right Brush

These factors need to be considered in order to select the right brush for your application.

- **Application Type:** guiding, shielding, sealing, positioning, conveying, cleaning, closing gaps, static dissipation
- **Environment:** wet/dry, acid/alkaline/solvent, hot/cold, FDA requirements, direct sun light, static or EMI present
- **Operation Cycles:** heavy, medium, light
- **Physical Properties:** soft or aggressive filament, synthetic/natural/metal filament, filament length
- **Stationary or Kinetic:** RPM, torque

When factors such as these are properly considered, selecting the right brush type, construction material, size, and filament for your application is ensured. The table below shows the properties and working environments for several commonly used filament materials. When selecting brush materials, the working environment is a primary consideration. The type of application (guiding, sealing, shielding, etc.) often determines which type of brush construction is best. Sections of this catalog describe each type of brush we manufacture and our general capabilities and specifications. Our web site, [www.sealeze.com](http://www.sealeze.com), provides additional information, specifications, white papers, reports and worksheets. Our experienced sales representatives are always available to help select the best brush for YOUR application.

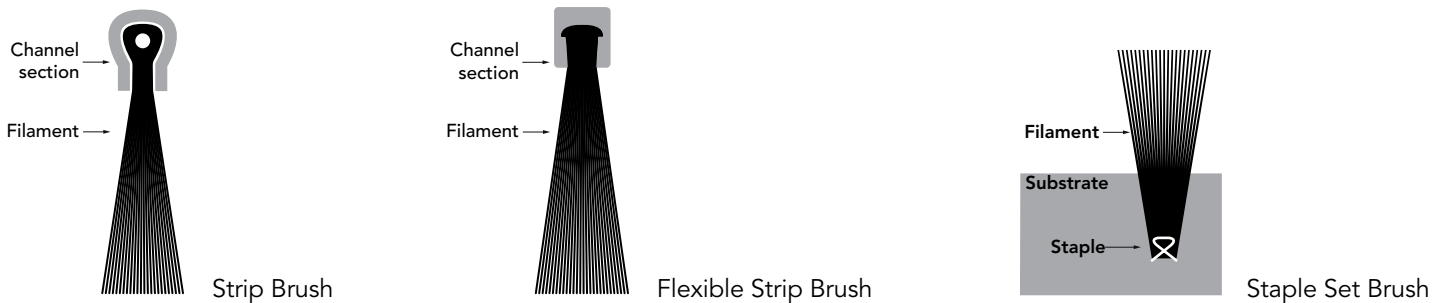

Properties	Nylon 6	Nylon 6.6	Nylon 6.12	Polypropylene	Polyester	Synthetic for Elevated Temp	Horse Hair	Tampico (plant)
Shape	Level or Crimped	Level or Crimped	Level or Crimped	Level or Crimped	Level or Crimped	Level	Level	Level
Flex Life	E	E	E	E	G	E	E	F
Springiness/Flicking	E	E	E	G	E	E	F	G
Bend Recovery	E	E	E	G	E	E	F	P
Resistance to Set	G	G	G	F	G	G	G	F
Abrasion Resistance	E	E	E	F	G	E	F	P
Water Absorption	9%	9%	3%	<0.2%	<0.5%	9%	—	—
Stiffness in Water	F	F	G	E	E	G	F	P
<b>Environment</b>								
Working Temperature (degrees F) (MAX)	200-230°F	200-230°F	200-230°F	180°F	200-230°F	250-300°F	na	na
Hot Water	G	G	G	E	E	G	P	E
Melting Point (degrees F)	410°F	500°F	415°F	320°F	430°F	495°F	—	—
Acidic	G	G	G	E	G	G	P	E
Alkaline	E	E	E	E	G	material dependent	—	—
Petroleum Distillates	E	E	E	G	G	E	—	—

E= Excellent, G= Good, F= Fair, P= Poor

All dimensions in inches, unless otherwise indicated. Dimensions are to Sealeze manufacturing tolerances. Contact us for more information on tolerances.

# Help and How to Order

## Contact Us

For immediate answers and free samples\*:

- Call: 800.787.7325  
804.743.0982
- Fax: 800.448.2908  
804.743.3413

- Visit: [www.sealeze.com](http://www.sealeze.com)
- Email: [industrial@sealeze.com](mailto:industrial@sealeze.com)

\* A 4-inch sample of a brush and holder will be sent to you following a discussion with a Sealeze sales representative regarding your application requirements.

## Terms and Condition of Sale and Payment Methods

**Sealeze Terms and Conditions of Sale are available on our website at [www.sealeze.com](http://www.sealeze.com).**

**Sealeze accepts Master Card, Visa, American Express and Discover. We offer payment terms to qualified customers who have completed our credit application with satisfactory credit checks and D&B ratings. Our credit application is available on our website at [www.sealeze.com](http://www.sealeze.com).**

## General Ordering

Sealeze's experienced sales representatives are available to assist you in ordering the right brush for your application. Depending on the type of brush you need, the information shown below will be necessary. Please take a few minutes to fill out the appropriate worksheet, ensuring accuracy regarding brush requirements. Contact a Sealeze Representative or visit our website to download a worksheet in PDF format.

### **For Straight Strip Brush Products:**

- Channel material: galvanized steel, stainless steel, flexible-backed, etc.
- Channel dimensions: X and Y or channel section size (A, B, C, etc.)
- Filament material: nylon, metal, polypropylene, etc.
- Filament diameter and shape (level or crimped)
- Filament trim length (OAT) or exposed length
- Holder material: aluminum, stainless steel, etc.
- Overall length of brushes and quantity required
- Holder dimensions: see Sealeze Stock Aluminum Holders for available shapes and dimensions

### **For Formed Strip Brush Products:**

- Inverted coil: OD and ID
- Exterior coil: ID and OD
- Inverted spiral: OD, ID, overall length and pitch
- External spiral: ID, OD, face length, pitch, mandrel (if any)
- Inverted arc: OR, IR, degrees of arc
- Quantity

### **For Staple Set Brush Products**

- Brush type: radial, strip, lag or disc
- Substrate material
- Filament material
- Dimensions: diameters, lengths, etc
- Quantity





8000 Whitepine Road  
North Chesterfield, VA 23237

800.446.7325  
804.743.1218  
fax: 800.448.2908  
804.743.3413  
weatherseal@sealeze.com

ISO 9001 Certified  
A Jason Company  
[www.sealeze.com](http://www.sealeze.com)

03.2015

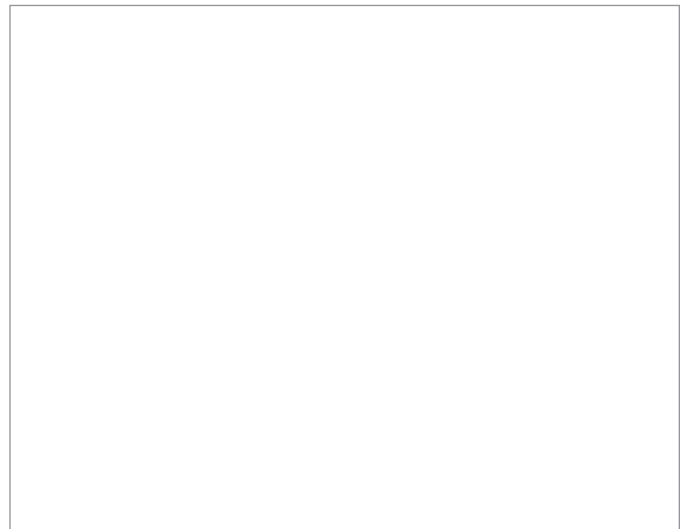

Contact your Sealeze Sales Representative