

# EDELMANN

## Oil Cooler Lines

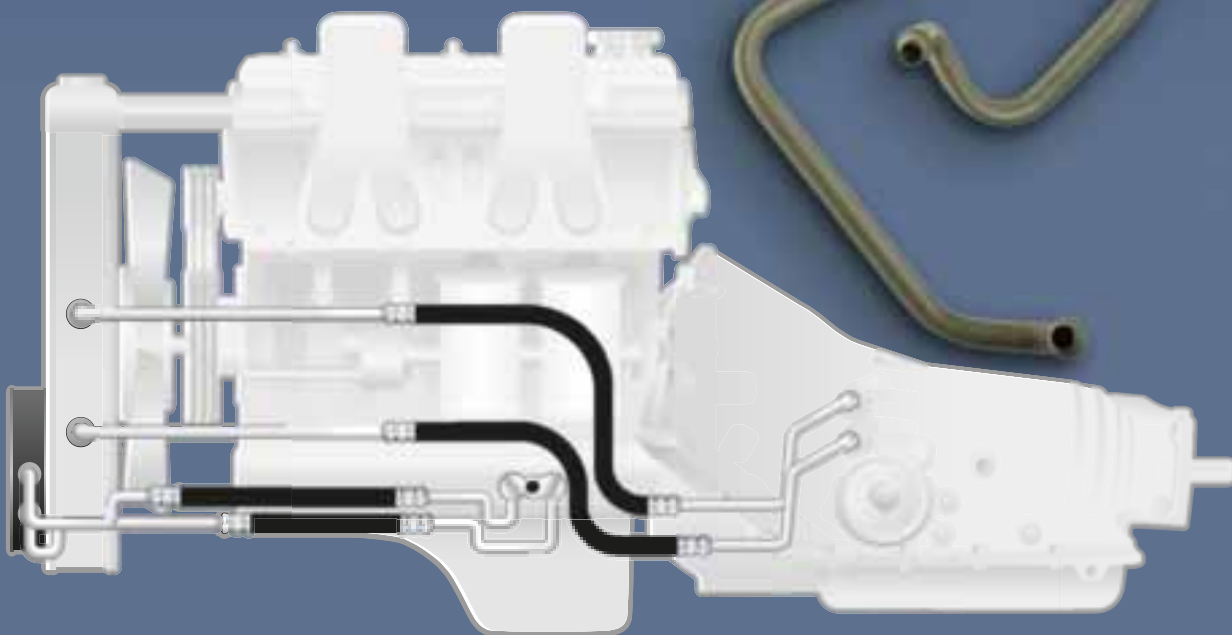

### *Engine Oil & Transmission Oil Cooler Lines*

**IMPORTANT  
TECH-TIPS  
INSIDE!**

## ***LIMITED WARRANTY***

**Warranty:** We make a commitment that our products, at the time of sale to the customer, meet standards applicable to uses recommended by the manufacturer. Our products will offer best service when installed, used and maintained according to our recommendations. If we determine that a product does not meet these standards, the product will, at our option, be replaced, repaired or credited. This is the exclusive remedy, limited to the customer's purchase price of the product. Damage to the product due to abuse, misuse, improper use, inadequate maintenance or failure to follow published installation, use and service recommendations automatically voids the warranty.

For warranty service, please contact your supplier or the Customer Service Department, Plews/Edelmann Division, Route 38, Airport Industrial Park, Dixon, Illinois, 61021.

THERE IS NO OTHER WARRANTY, EXPRESSED OR IMPLIED, INCLUDING FITNESS FOR A PARTICULAR PURPOSE. ALL IMPLIED WARRANTIES ARE EXPRESSLY DISCLAIMED. LIABILITY FOR CONSEQUENTIAL OR INCIDENTAL DAMAGES UNDER ANY AND ALL WARRANTIES ARE EXCLUDED TO THE EXTENT EXCLUSION IS PERMITTED BY LAW.

## ***TRANSMISSION OR ENGINE OIL COOLER LINE PROBLEMS?***



### ***Call Us On Our Toll Free Numbers***

For Technical Assistance Only  
Call **1-800-323-6294**

For Placing Orders Only  
Call Customer Service  
**1-800-770-4639**

# TABLE OF CONTENTS

<b>Product Section .....</b>	<b>A2–A9</b>
<b>Troubleshooting .....</b>	<b>A10–A12</b>
<b>EOC Applications .....</b>	<b>1–10</b>
<b>TOC Applications .....</b>	<b>11–114</b>
<b>Numerical Listing .....</b>	<b>115–179</b>
<b>Manufacturers' Part Numbers .....</b>	<b>180–182</b>
<b>End Fittings .....</b>	<b>183–187</b>
<b>Illustrations .....</b>	<b>188–270</b>

Product Section

Troubleshooting

EOC Applications

TOC Applications

Numerical Listing

Manufacturers'  
Part Numbers

End Fittings

Illustrations

# Cooler Line Highlights

Welcome to the world of transmission and engine oil cooler lines. Here are the most critical pieces of information in understanding this category!

## Identifying Your Cooler Line

Transmission oil cooler lines are typically routed along the **passenger** side of the vehicle under the hood. Leaking fluid will be red.

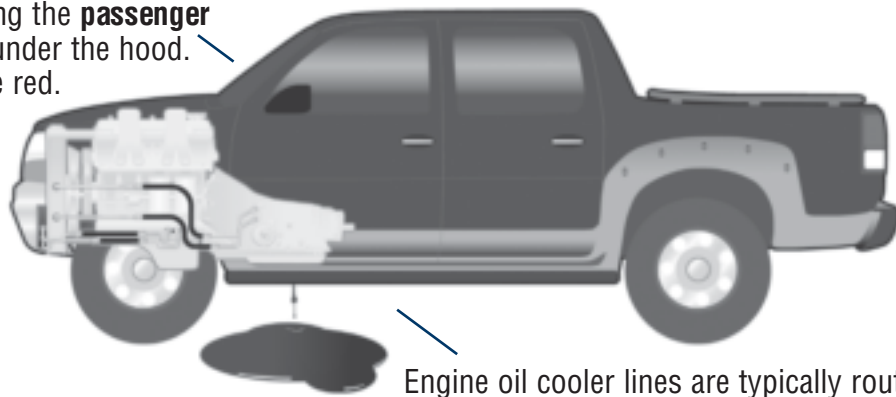

Engine oil cooler lines are typically routed along the **driver** side of the vehicle under the hood. Leaking fluid will be brown or black.

## Terminology in This Catalog

**UPPER** — Assembly is physically routed into radiator at the higher position.

**LOWER** — Assembly is physically routed into radiator at the lower position.

**INLET** — Assembly carries flow of oil **IN** to cooler from engine.

**OUTLET** — Assembly carries flow of oil **OUT** of cooler into engine.

Some nomenclature, like below is listed to help you match part numbers listed in our application section with the location of an assembly on the vehicle.

**DRIVER SIDE** — Assembly connects to cooler on driver side of vehicle.

**PASSENGER SIDE** — Assembly connects to cooler on passenger side of vehicle.

The information found on pages A10-A11 is also available as a handy installer tech-tip wall poster. Ask your sales representative about this piece (PE-0068).

## Using This Catalog

While there is a great deal of information in this catalog, it is only useful if you understand how to identify the hose assembly you need and verify it.

- Identify hose part number by application given in application section.  
(Make/Model/Year/Engine Size/Qualifiers)
- Verify hose by illustration section with digital image.
- Confirm hose by OEM number (if available on original hose) in our Manufacturers' Part Numbers Section

## *Typical Engine with Engine Oil Cooler Lines*

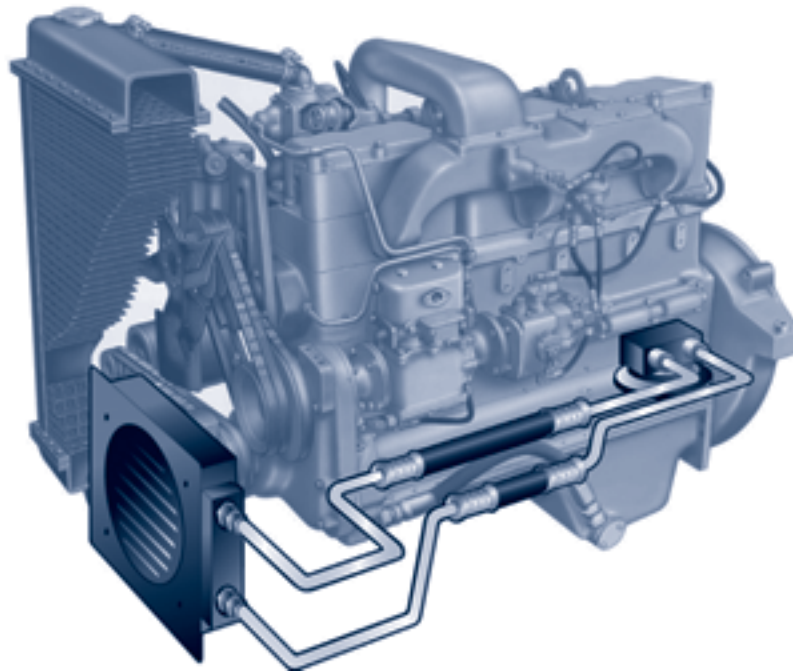

- Engine oil cooler lines are found on many late-model light trucks, vans, SUVs and vehicles with tow packages.
- The primary function of engine oil cooler lines is to carry hot engine oil away from the engine to an external cooler typically located in front of or around the radiator. The oil is cooled, then cycled back to the engine through an outlet hose.
- The external cooler associated with these lines is typically located in front of the radiator.
- When replacing other engine components, do not contaminate the new engine oil and system by reinstalling old cooler lines. Hoses will break down internally over time from heat, and trapped particles can cycle through the system causing further damage.

## Transmission Oil Cooler Assemblies OEM Fit and Performance

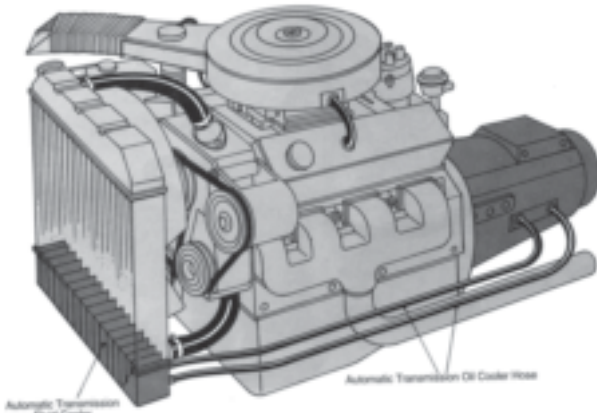

**Down-Flow Radiator**

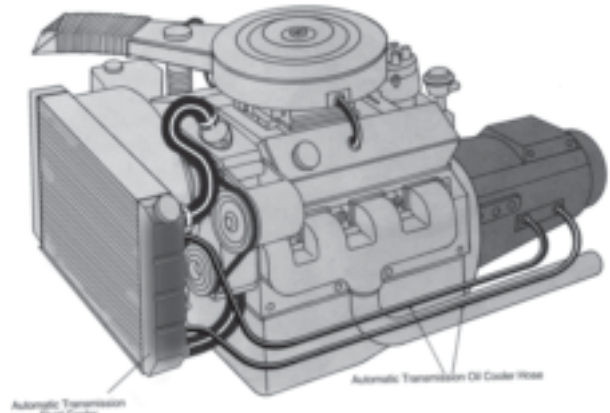

**Cross-Flow Radiator**

### **Until now, the only source for replacing Transmission Cooler Lines was the OE Dealership.**

- With the complexities of today's vehicles, it is always recommended that you replace a transmission oil cooler line with a new assembly that follows the original equipment design. OE-designed assemblies allow the automatic transmission fluid (ATF) to cool down during the cycle of the fluid. "Quick Fix" or short-cutting repairs can greatly reduce ATF life and could compromise the transmission. A new transmission can cost over \$2,000 to replace.
- Automatic transmission fluid cools by traveling out of the transmission via the oil cooler line to a reservoir in the radiator. The cooled fluid from the radiator dissipates the ATF heat and is then returned to the transmission for another cycle. In a down-flow radiator, the transmission oil cooler is located in the bottom portion of the radiator. In a cross-flow radiator, the transmission oil cooler is located in the side of the radiator.
- Transmission oil cooler assemblies consist of metal tubing or an assembly of metal tubing and rubber hose. Transmission oil cooler hose is used to absorb engine and road vibration.
- While ATF was designed to operate at temperatures of 175°F, the reality is that transmission and cooling lines are routinely subjected to conditions that cause it to operate at 220°F or more, up to 300°F intermittent. As the heat goes up, assembly life goes down.
- Transmission cooler lines are also subjected to high pressure. On older vehicles, 75 to 150 psi is standard. Surges up to 300 psi can be seen on newer electronically controlled transmissions. A small leak under these pressures can lead to serious problems.

## Transmission Oil Cooler Assemblies

OEM Fit and Performance

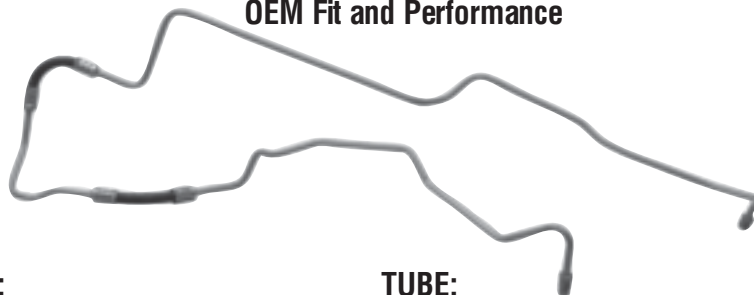

### HOSE:

**Tube:** CPE

**Cover:** Hypalon

**Temperature:** 300°F

### TUBE:

**Original Equipment Ends**

**Pro Coated Tubes**

Protects against rust and corrosion

**Single Lock Beading with Barbed Tube Ends**

Superior hose/coupling integrity

**Heat and Abrasion Guard Where Needed**

## Engine Oil Cooler Assemblies

OEM Fit and Performance

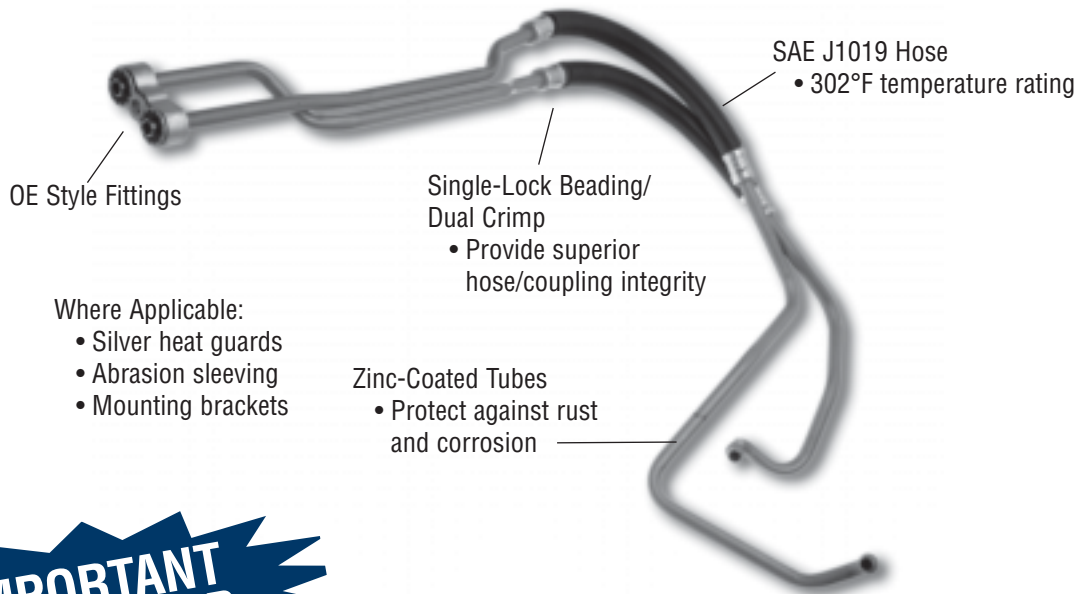

Where Applicable:

- Silver heat guards
- Abrasion sleeving
- Mounting brackets

**IMPORTANT SERVICE TIP**

## Connectors and Fittings

OEM Fit and Quality Equivalent

- It is recommended to always replace fittings when changing a line. If the opportunity to change fittings does not exist, you should make sure you can install new clips, O-rings and washers.



## Patented Jiffy-Tite® Tool

Part No: A63200

Tools designed to quickly and easily remove the transmission oil cooler assembly from the adapter on GM vehicles.



## Two Standard Tool Kits

Quickly separates coupling and tubing on popular domestic and import vehicles. Use on transmission, engine oil cooler, air conditioning, radiator and fuel lines.

Part No: A63201

6-Piece Quick Disconnect



Part No: A63202

8-Piece Quick Disconnect



## DIY Tool and Clips

Part No: A63301 (3/8")

Part No: A63302 (1/2")

Perfect for the do-it-yourselfer. One plastic tool for quick and easy removal of the transmission oil cooler assembly with two spare clips.





## Assortments

### O-Ring and Washer Kit

**Part No: A63303**

An assortment of the most popular O-rings and sealing washers used on transmission oil cooler assemblies today. Kit contains 25 each of the following:

Part No.	Part No.	Part No.
A63089	A63090	A63091
A63093	A63094	A63095
A63096	A63097	A63100
A63101	A63102	A63103
A63104	A63105	A63106
A63107	A63108	A63109

Replacement O-rings and washers sold in packages of 25.

### GM Clip Assortment

**Part No: A63300**

An assortment of the three most popular sizes of Jiffy-Tite® clips used on GM vehicles.

Part No.	Qty.
A63098	25
A63099	10
A63110	10

Replacement GM retainer clips sold in packages of 25.



## Bulk Hose

**Tube:** CPE

**Cover:** Hypalon

**Temperature:** 300°F

Part No.	DESCRIPTION	Length
A63000	5/16" Bulk Hose	25'
A63001	3/8" Bulk Hose	25'
A63002	1/2" Bulk Hose	10'
A63003	5/8" Bulk Hose	10'
A63004	5/16" Bulk Tubing	25'
A63005	3/8" Bulk Tubing	25'
A63111	5/16" Bulk Hose	3'
A63112	3/8" Bulk Hose	3'
A63113	1/2" Bulk Hose	3'
A63114	5/8" Bulk Hose	3'



# QUALITY

# COVERAGE

## Installer Repair Problems

Engine cavitations, road vibration and reduced underhood space can have an effect on your hydraulic hoses.

- Improperly routed assemblies can frequently be pinched or kinked against the frame or other hard parts causing premature failure.
- Additionally, heat dissipation is critical to the longevity of the assembly and can be greatly reduced by shortening the assembly or not using the correct length of tubing.

Edelmann design and materials ensure that your customer will not experience these problems when you fix their vehicle with Edelmann Engine and Transmission Oil Cooler Lines.

As with power steering, we have paid close attention to:

- Duplicating the original routing
- OEM-style fittings
- Safety features
- Methods of assembly

We use only quality materials in the manufacturing of all our Oil Cooler Lines for years of trouble-free driving:

- Rubber hose meets or exceeds OEM specifications to withstand the high heat under-the-hood of today's vehicles
- Zinc-coated steel tubes protect against rust and corrosion

We carefully study what the OEM puts on the vehicle to make sure that what you get matches the original in form, fit and function.

We want to make sure that when it goes out your door, it doesn't come back!

We have criss-crossed the country talking to repair shop professionals, like yourself. We have identified the most failure prone vehicles in this category as:

EOC - Late model Chevy/GMC Blazers, Jimmys, pickups, Astro vans, Suburbans and Yukons.

TOC - Late model Dodge trucks, Chrysler mini-vans and GM front-wheel drives.

We covered not only these applications, but many more. Edelmann offers you the ability to say "yes" to your customer every time.

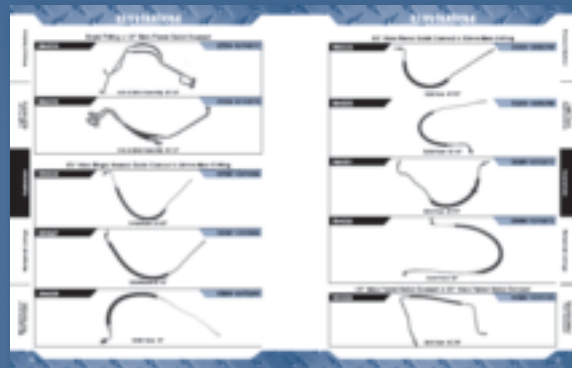

Our catalog research goes through rigorous filters and checks to bring you the exact information you need in an easy format.

Electronic rollouts happen six times a year to continuously bring you up-to-date coverage on new assemblies!

A hallmark of our power steering line offering has been to continuously add new coverage to meet the growing needs of the market. We are supporting our Oil Cooler Lines with the same diligence.



# AVAILABILITY

# SAVINGS



Until now, your best source for Oil Cooler Lines was the dealership. But dealerships haven't always stocked the model year coverage you require. Now, we manufacture and are making available to you the hard-to-find parts that you need.

Edelmann has the availability on older vehicles giving you those hard-to-find parts in addition to the many fittings, seals and other parts that should be replaced when you do a repair.

In many cases, not replacing O-rings, seals, clips, brackets, etc. can lead your customer right back to you.

Edelmann directly services thousands of customers and has products distributed through tens of thousands of warehouses and jobbers in all 50 states, Canada, Mexico, Puerto Rico and across the globe.

Our distribution network ensures that our product will be available through the local distribution partner you have come to know and trust.

Time is money and you can save both by partnering with Edelmann today!

Our efforts to bring you the very best quality, coverage and availability easily translates into savings.

- Edelmann quality means you will save time by getting a hose that will fit every time, clearing your bay quicker.
- Edelmann coverage means you will save time by not having to search around town for hard-to-find parts.
- Edelmann availability means you will save the sale by knowing the part will be available the same day. You will know who to put at the top of your speed dial.
- Edelmann hydraulic lines are competitively priced against the OEM dealerships enabling you to improve profit on the parts that you buy.



# WHICH LINE

## TRANSMISSION OIL COOLER LINE



Transmission oil cooler lines are typically 5'-6' in length

Female quick connect fittings can only be found on transmission oil cooler lines

### Installation Tips

Hose diameter is typically 5/16" or 3/8"

### TOC – Transmission Oil Cooler Lines

#### • When Changing:

- Flush transmission/change the filter and replace fluids.
- Replace Quick Connect Fittings: Do not reuse the O-rings as they can shrink, become hard or brittle and may not seal properly with the new line.
- Take note of the color and odor of fluid prior to flushing. If color is dark or brown and there is a burnt odor, this may be an indication of worn, burnt or damaged plates.

Leaking transmission fluid will typically have a red tint

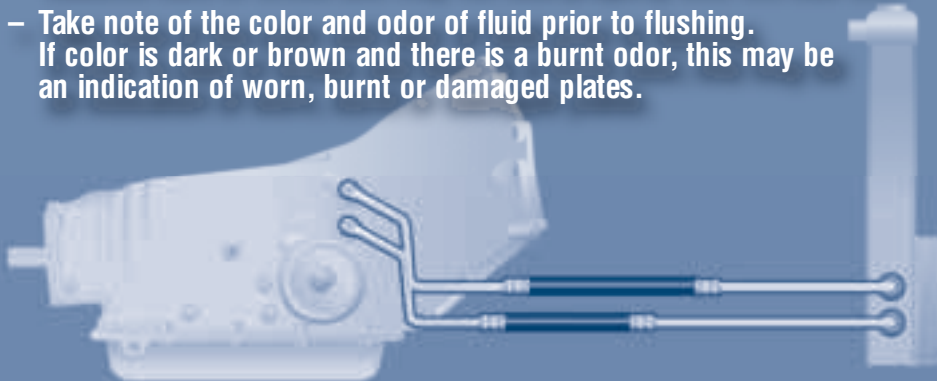

### TOC – Transmission Oil Cooler Lines

- The routing of transmission lines will go from the radiator into the transmission bell housing.
- Transmission lines can have both rubber and coupled steel tubing in addition to only steel tubing lines.

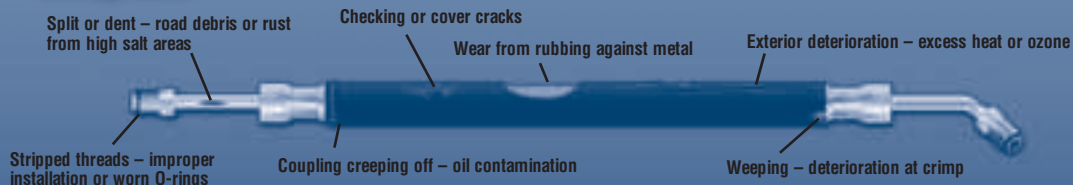

# IS LEAKING?

## ENGINE OIL COOLER LINE

Dual-block fittings can only be found on engine oil cooler lines

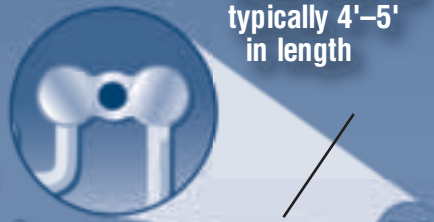

Engine oil cooler lines are typically 4'-5' in length



Hose diameter is typically 1/2" or 5/8"

Leaking engine oil will typically be brown or black in color and may have a burnt odor

### Tech Tips:

Routing of your hydraulic line assembly is critical due to many factors including road vibration and heat dissipation. Install an assembly that follows the OEM routing. Not doing so can cause kinking, pinching and premature failure.

Upon completing an installation, it is always wise to clean and dry the affected areas to show the customer the leak no longer exists. Leaving it may cause your customer to question the repair.

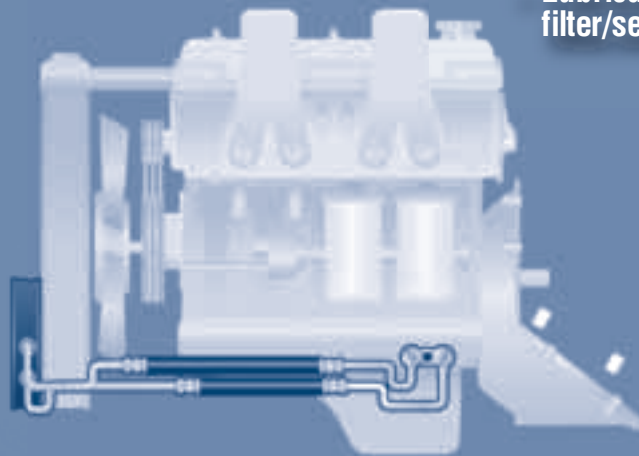

### EOC – Engine Oil Cooler Lines

- The routing of engine oil cooler lines will also go from the radiator, but will be routed into the engine casing.
- All engine oil cooler lines have some portion of rubber in them.

### Installation Tips

#### EOC – Engine Oil Cooler Lines

- When Changing:
  - Change oil and filter.
  - Replace Quick Connect Fittings: Do not reuse the O-rings as they can shrink, become hard or brittle and may not seal properly with the new line.
  - Remember to tighten oil drain plugs and filter.
  - Check for metal chips on oil drain plug.
  - Lubricate seal or filter/seal could tear.

# TROUBLESHOOTING GUIDE

Product Section

Troubleshooting

EOC Applications

TOC Applications

Numerical Listing

Manufacturers' Part Numbers

End Fittings

Illustrations

Most problems in transmissions and engines are the result of leaking hoses, fittings, gaskets and O-rings. Repairing or adjusting these problems does not involve extremely complicated procedures.

In the composite drawing and in the table below, various types of transmission and engine oil cooler assembly problems are illustrated.

Because of exposure to underhood heat, high fluid temperatures, ozone, flexing, abrasion, grease and oil, assemblies and hoses should be inspected and replaced, if necessary, to ensure safe operation.

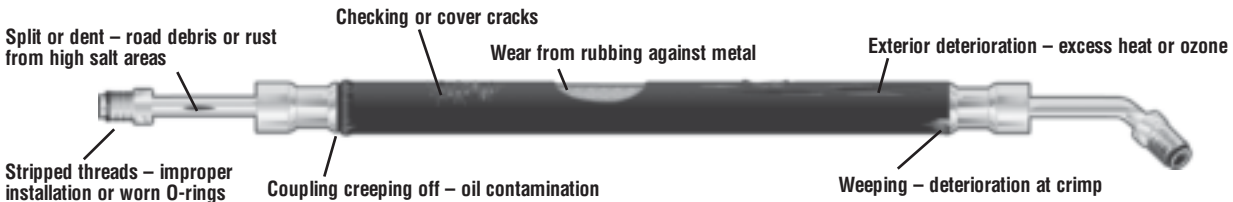

Symptom	Cause
Oil "weeping" from hose and coupling	Deterioration of hose at crimp due to excessive heat
Exterior deterioration	Oil contamination of hose Prolonged exposure to ozone Excess heat Wear from rubbing Checking (cover cracks) Road debris
Coupling separation	Oil contamination Excess heat Hose reinforcement separation
Split or dented tubing	Road debris Rust due to environments with high salt concentrations Accidents
Leaking at thread configuration	Improper installation Stripped threads Worn O-rings or gaskets

**Preventive Maintenance Tip:** Low fluid levels can seriously damage the transmission, so it's wise to check it when checking engine oil. A drop in transmission fluid level indicates there might be a leak in the transmission oil cooler line.

Overheating will also cause a drop in fluid levels. See the chart below for how much a 20°F increase in operating temperatures can reduce oil and transmission life.

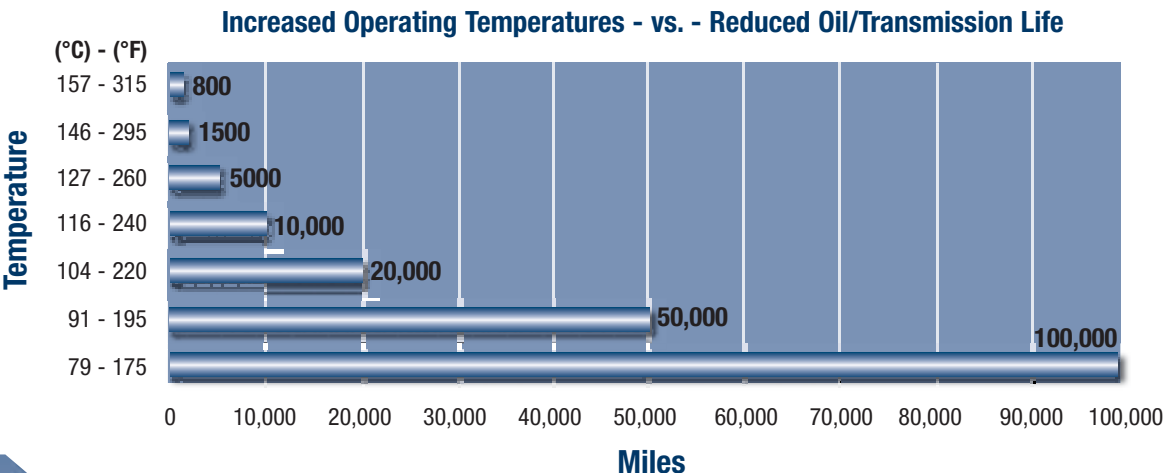

# Engine Oil Cooler Assemblies for Light Trucks Alphabetical Listing

Application	Assembly Number	Application	Assembly Number
<b>CADILLAC</b>		<b>CHEVROLET - Continued</b>	
<b>ESCALADE</b>		<b>BLAZER - Continued</b>	
<b>2000-1999</b>		<b>1994</b>	
<b>V-8 5.7 L ENG.</b>		<b>V-6 4.3 L ENG.</b>	
Inlet (Lower); W/2WD .....	B64230	Inlet & Outlet Assy. From Oil Filter to Rad.; W/4WD; Eng. VIN W .....	B64261
Inlet (Lower); W/4WD .....	B64210	Inlet & Outlet Assy. From Oil Filter to Rad.; W/4WD; Eng. VIN Z .....	B64260
Outlet (Upper); W/2WD .....	B64229	Inlet & Outlet Assy. To Remote Oil Filter; W/4WD .....	B64219
Outlet (Upper); W/4WD .....	B64211	Inlet (Lower); W/2WD .....	B64263
<b>CHEVROLET</b>		Outlet (Upper); W/2WD; Eng. VIN Z .....	
IMPORTANT: PLEASE NOTE. To select correct replacement parts, it may be necessary to identify the code character for the engine by looking at the VIN (Vehicle Identification Number) located on the dash panel. For 1981 and newer cars, refer to the 8th digit of VIN for the correct engine code. For 1980 and older cars, refer to the 5th digit of VIN for the correct engine code.		B64264	
<b>ASTRO</b>		<b>V-8 5.7 L ENG.</b>	
<b>2005-1996</b>		Inlet (Upper); W/4WD .....	
<b>V-6 4.3 L ENG.</b>		B64208	
Inlet & Outlet Assy. ....	B64222	Outlet (Lower); W/4WD .....	
<b>1995</b>		B64209	
<b>V-6 4.3 L ENG.</b>		<b>V-8 6.5 L DIESEL ENG.</b>	
Inlet (Upper) .....	B64240	Aux. Cooler Inlet (Pass. Side) .....	
Outlet (Lower) .....	B64239	B64253	
<b>1994</b>		Aux. Cooler Outlet (Driver Side) .....	
<b>V-6 4.3 L ENG.</b>		B64252	
Inlet (Upper); W/2WD .....	B64241	<b>1993-1992</b>	
Outlet (Lower); W/2WD .....	B64242	<b>V-6 4.3 L ENG.</b>	
<b>1993-1990</b>		Inlet & Outlet Assy. From Oil Filter to Rad.; W/4WD; Eng. VIN W .....	
<b>V-6 4.3 L ENG.</b>		B64261	
Inlet (Upper); W/2WD .....	B64200	Inlet & Outlet Assy. From Oil Filter to Rad.; W/4WD; Eng. VIN Z .....	
Outlet (Lower); W/2WD .....	B64201	B64260	
<b>1989-1985</b>		Inlet & Outlet Assy. To Remote Oil Filter; W/4WD .....	
<b>V-6 4.3 L ENG.</b>		B64219	
Inlet (Upper) .....	B64200	Inlet (Lower); W/2WD .....	
Outlet (Lower) .....	B64201	B64263	
<b>BLAZER</b>		Outlet (Upper); W/2WD; Eng. VIN Z .....	
<b>2005-1996</b>		B64264	
<b>V-6 4.3 L ENG.</b>		<b>V-8 5.7 L ENG.</b>	
Inlet & Outlet Assy.; W/2WD .....	B64224	Aux. Cooler Inlet (Pass. Side); W/4WD .....	
Inlet & Outlet Assy. From Oil Filter to Rad.; W/4WD .....	B64225	B64269	
Inlet & Outlet Assy. To Eng. Block Adapter; W/4WD .....	B64220	Aux. Cooler Outlet (Driver Side); W/4WD .....	
<b>1995</b>		B64270	
<b>V-6 4.3 L ENG.</b>		Inlet (Lower); W/2WD .....	
Inlet & Outlet Assy. From Oil Filter to Rad.; W/4WD .....	B64223	B64216	
Inlet & Outlet Assy. To Eng. Block Adapter; W/4WD .....	B64221	Inlet (Upper); W/4WD; W/O Aux. Cooler .....	
Inlet (Upper); W/2WD .....	B64204	B64247	
Outlet (Lower); W/2WD .....	B64205	Outlet (Lower); W/4WD; W/O Aux. Cooler .....	
		B64248	
		Outlet (Upper); W/2WD .....	
		B64226	
		<b>1991-1990</b>	
		<b>V-6 4.3 L ENG.</b>	
		Inlet & Outlet Assy. From Oil Filter to Rad.; W/4WD .....	
		B64261	
		Inlet & Outlet Assy. To Remote Oil Filter; W/4WD .....	
		B64219	
		Inlet (Lower); W/2WD .....	
		B64263	
		Outlet (Upper); W/2WD .....	
		B64264	
		<b>V-8 5.7 L ENG.</b>	
		Aux. Cooler Inlet (Pass. Side) .....	
		B64243	
		Aux. Cooler Outlet (Driver Side) .....	
		B64244	
		<b>V-8 6.2 L DIESEL ENG.</b>	
		Inlet Hose (Upper) From Eng. Block .....	
		B64277	
		Outlet Hose (Lower) From Eng. Block .....	
		B64278	
		<b>1989-1988</b>	
		<b>V-6 4.3 L ENG.</b>	
		Inlet & Outlet Assy. From Oil Filter to Rad.; W/4WD .....	
		B64260	
		Inlet & Outlet Assy. To Remote Oil Filter; W/4WD .....	
		B64219	
		Inlet (Lower); W/2WD .....	
		B64263	
		Outlet (Upper); W/2WD .....	
		B64264	
		<b>V-8 5.7 L ENG.</b>	
		Aux. Cooler Inlet (Pass. Side) .....	
		B64243	
		Aux. Cooler Outlet (Driver Side) .....	
		B64244	
		<b>V-8 6.2 L DIESEL ENG.</b>	
		Inlet Hose (Upper) From Eng. Block .....	
		B64277	
		Outlet Hose (Lower) From Eng. Block .....	
		B64278	

See Pages 11 - 114 for Transmission Oil Cooler Applications.

## Engine Oil Cooler Assemblies for Light Trucks

Application	Assembly Number	Application	Assembly Number
<b>CHEVROLET - Continued</b>		<b>CHEVROLET - Continued</b>	
<b>C &amp; K SERIES PICKUP</b>		<b>C &amp; K SERIES PICKUP - Continued</b>	
<b>2000</b>		<b>1997 - Continued</b>	
<b>V-8 5.7 L ENG.</b>		<b>V-8 7.4 L ENG. - Continued</b>	
Inlet (Lower); W/2WD .....	B64229	Outlet (Upper); Exc. 3500HD .....	B64232
Inlet (Lower); W/4WD .....	B64210		
Outlet (Upper); W/2WD .....	B64230		
Outlet (Upper); W/4WD .....	B64211		
<b>V-8 7.4 L ENG.</b>		<b>1996</b>	
Inlet (Lower) .....	B64231	<b>V-6 4.3 L ENG.</b>	
Outlet (Upper); 3500HD .....	B64274	Inlet (Upper) .....	B64249
Outlet (Upper); Exc. 3500HD .....	B64232	Outlet (Lower) .....	B64250
<b>1999</b>		<b>V-8 5.0 L ENG.</b>	
<b>V-8 5.0 L ENG.</b>		Inlet (Lower); W/140A. Alt.; W/2WD .....	
Inlet (Lower); W/140A. Alt.; W/2WD .....	B64229	Inlet (Lower); W/140A. Alt.; W/4WD .....	B64229
Inlet (Lower); W/140A. Alt.; W/4WD .....	B64210	Outlet (Upper); W/140A. Alt.; W/2WD .....	B64210
Outlet (Upper); W/140A. Alt.; W/2WD .....	B64230	Outlet (Upper); W/140A. Alt.; W/4WD .....	B64230
Outlet (Upper); W/140A. Alt.; W/4WD .....	B64211	Outlet (Upper); W/140A. Alt.; W/4WD .....	B64211
<b>V-8 5.7 L ENG.</b>		<b>V-8 5.7 L ENG.</b>	
Inlet (Lower); W/2WD .....	B64229	Inlet (Lower); W/2WD .....	B64229
Inlet (Lower); W/4WD .....	B64210	Inlet (Lower); W/4WD .....	B64210
Outlet (Upper); W/2WD .....	B64230	Outlet (Upper); W/2WD .....	B64230
Outlet (Upper); W/4WD .....	B64211	Outlet (Upper); W/4WD .....	B64211
<b>V-8 7.4 L ENG.</b>		<b>V-8 6.5 L DIESEL ENG.</b>	
Inlet (Lower) .....	B64231	Inlet (Driver Side); 3500HD .....	B64258
Outlet (Upper); 3500HD .....	B64274	Inlet (Driver Side); Exc. 3500HD .....	B64214
Outlet (Upper); Exc. 3500HD .....	B64232	Outlet (Pass. Side); 3500HD .....	B64259
		Outlet (Pass. Side); Exc. 3500HD .....	B64215
<b>1998</b>		<b>V-8 7.4 L ENG.</b>	
<b>V-6 4.3 L ENG.</b>		Inlet (Lower) .....	
Inlet (Upper) .....	B64249	Outlet (Upper); 3500HD .....	B64231
Outlet (Lower) .....	B64250	Outlet (Upper); Exc. 3500HD .....	B64274
<b>V-8 5.0 L ENG.</b>		Outlet (Upper); Exc. 3500HD .....	
Inlet (Lower); W/140A. Alt.; W/2WD .....	B64229		
Inlet (Lower); W/140A. Alt.; W/4WD .....	B64210		
Outlet (Upper); W/140A. Alt.; W/2WD .....	B64230		
Outlet (Upper); W/140A. Alt.; W/4WD .....	B64211		
<b>V-8 5.7 L ENG.</b>		<b>1995</b>	
Inlet (Lower); W/2WD .....	B64229	<b>V-6 4.3 L ENG.</b>	
Inlet (Lower); W/4WD .....	B64210	Inlet (Upper) .....	B64271
Outlet (Upper); W/2WD .....	B64230	Outlet (Lower) .....	B64272
Outlet (Upper); W/4WD .....	B64211	<b>V-8 5.0 L ENG.</b>	
<b>V-8 7.4 L ENG.</b>		Inlet (Lower); W/2WD .....	
Inlet (Lower) .....	B64231	Inlet (Upper); W/4WD .....	B64217
Outlet (Upper); 3500HD .....	B64274	Outlet (Lower); W/4WD .....	B64218
Outlet (Upper); Exc. 3500HD .....	B64232	Outlet (Upper); W/2WD .....	B64228
		Outlet (Lower); W/4WD .....	B64227
<b>1997</b>		<b>V-8 5.7 L ENG.</b>	
<b>V-6 4.3 L ENG.</b>		Inlet (Lower); W/2WD .....	
Inlet (Upper) .....	B64249	Inlet (Lower); W/4WD .....	B64245
Outlet (Lower) .....	B64250	Inlet (Upper); W/4WD .....	B64208
<b>V-8 5.0 L ENG.</b>		Outlet (Lower); W/4WD .....	
Inlet (Lower); W/140A. Alt.; W/2WD .....	B64229	Outlet (Upper); W/2WD .....	B64209
Inlet (Lower); W/140A. Alt.; W/4WD .....	B64210	Outlet (Upper); W/2WD .....	B64246
Outlet (Upper); W/140A. Alt.; W/2WD .....	B64230	<b>V-8 6.5 L DIESEL ENG.</b>	
Outlet (Upper); W/140A. Alt.; W/4WD .....	B64211	Inlet (Driver Side); 3500HD .....	
<b>V-8 5.7 L ENG.</b>		Inlet (Driver Side); Exc. 3500HD .....	
Inlet (Lower); W/2WD .....	B64229	Outlet (Pass. Side); 3500HD .....	
Inlet (Lower); W/4WD .....	B64210	Outlet (Pass. Side); Exc. 3500HD .....	
Outlet (Upper); W/2WD .....	B64230	<b>V-8 7.4 L ENG.</b>	
Outlet (Upper); W/4WD .....	B64211	Inlet (Lower); W/O Aux. Cooler .....	
<b>V-8 7.4 L ENG.</b>		Outlet (Upper); W/O Aux. Cooler .....	
Inlet (Lower) .....	B64231		
Outlet (Upper); 3500HD .....	B64274		
Outlet (Upper); Exc. 3500HD .....	B64232		
<b>1997</b>		<b>1994</b>	
<b>V-6 4.3 L ENG.</b>		<b>V-6 4.3 L ENG.</b>	
Inlet (Upper) .....	B64249	Inlet (Upper) .....	B64271
Outlet (Lower) .....	B64250	Outlet (Lower) .....	B64272
<b>V-8 5.0 L ENG.</b>		<b>V-8 5.0 L ENG.</b>	
Inlet (Lower); W/140A. Alt.; W/2WD .....	B64229	Inlet (Lower); W/2WD .....	
Inlet (Lower); W/140A. Alt.; W/4WD .....	B64210	Inlet (Upper); W/4WD .....	
Outlet (Upper); W/140A. Alt.; W/2WD .....	B64230	Outlet (Lower); W/4WD .....	
Outlet (Upper); W/140A. Alt.; W/4WD .....	B64211	Outlet (Upper); W/2WD .....	
<b>V-8 5.7 L ENG.</b>		<b>V-8 5.7 L ENG.</b>	
Inlet (Lower); W/2WD .....	B64229	Inlet (Lower); W/2WD; Exc. Chassis Cab .....	
Inlet (Lower); W/4WD .....	B64210	Inlet (Lower); W/2WD; W/Chassis Cab .....	
Outlet (Upper); W/140A. Alt.; W/2WD .....	B64230	Inlet (Upper); W/4WD; Exc. Chassis Cab .....	
Outlet (Upper); W/140A. Alt.; W/4WD .....	B64211	Inlet (Upper); W/4WD; W/Chassis Cab .....	
<b>V-8 7.4 L ENG.</b>		Outlet (Lower); W/4WD; Exc. Chassis Cab .....	
Inlet (Lower) .....	B64231	Outlet (Lower); W/4WD; W/Chassis Cab .....	
Outlet (Upper); 3500HD .....	B64274	Outlet (Upper); W/2WD; Exc. Chassis Cab .....	
Outlet (Upper); Exc. 3500HD .....	B64232	Outlet (Upper); W/2WD; W/Chassis Cab .....	
<b>1997</b>		<b>1994</b>	
<b>V-6 4.3 L ENG.</b>		<b>V-6 4.3 L ENG.</b>	
Inlet (Upper) .....	B64249	Inlet (Upper) .....	B64271
Outlet (Lower) .....	B64250	Outlet (Lower) .....	B64272
<b>V-8 5.0 L ENG.</b>		<b>V-8 5.0 L ENG.</b>	
Inlet (Lower); W/140A. Alt.; W/2WD .....	B64229	Inlet (Lower); W/2WD .....	
Inlet (Lower); W/140A. Alt.; W/4WD .....	B64210	Inlet (Upper); W/4WD .....	
Outlet (Upper); W/140A. Alt.; W/2WD .....	B64230	Outlet (Lower); W/4WD .....	
Outlet (Upper); W/140A. Alt.; W/4WD .....	B64211	Outlet (Upper); W/2WD .....	
<b>V-8 5.7 L ENG.</b>		<b>V-8 5.7 L ENG.</b>	
Inlet (Lower); W/2WD .....	B64229	Inlet (Lower); W/2WD; Exc. Chassis Cab .....	
Inlet (Lower); W/4WD .....	B64210	Inlet (Lower); W/2WD; W/Chassis Cab .....	
Outlet (Upper); W/140A. Alt.; W/2WD .....	B64230	Inlet (Upper); W/4WD; Exc. Chassis Cab .....	
Outlet (Upper); W/140A. Alt.; W/4WD .....	B64211	Inlet (Upper); W/4WD; W/Chassis Cab .....	
<b>V-8 7.4 L ENG.</b>		Outlet (Lower); W/4WD; Exc. Chassis Cab .....	
Inlet (Lower) .....	B64231	Outlet (Lower); W/4WD; W/Chassis Cab .....	
Outlet (Upper); 3500HD .....	B64274	Outlet (Upper); W/2WD; Exc. Chassis Cab .....	
Outlet (Upper); Exc. 3500HD .....	B64232	Outlet (Upper); W/2WD; W/Chassis Cab .....	

See Pages 11 - 114 for Transmission Oil Cooler Applications.



## Engine Oil Cooler Assemblies for Light Trucks

Application	Assembly Number	Application	Assembly Number
<b>CHEVROLET - Continued</b>		<b>CHEVROLET - Continued</b>	
<b>C &amp; K SERIES PICKUP - Continued</b>		<b>C &amp; K SERIES PICKUP - Continued</b>	
<b>1994 - Continued</b>		<b>1990-1989 - Continued</b>	
<b>V-8 6.5 L DIESEL ENG.</b>		<b>V-8 5.7 L ENG.</b>	
Aux. Cooler Inlet (Pass. Side); Exc. 3500HD.....	B64253	Aux. Cooler Inlet (Driver Side); W/4WD .....	B64269
Aux. Cooler Outlet (Driver Side); Exc. 3500HD .....	B64252	Aux. Cooler Outlet (Pass. Side); W/4WD .....	B64273
<b>V-8 7.4 L ENG.</b>		Inlet (Lower); W/O Aux. Cooler; W/2WD .....	B64217
Inlet (Lower); W/O Aux. Cooler .....	B64212	Inlet (Upper); W/O Aux. Cooler; W/4WD .....	B64218
Outlet (Upper); W/O Aux. Cooler .....	B64213	Outlet (Lower); W/O Aux. Cooler; W/4WD .....	B64228
<b>1993-1992</b>		Outlet (Upper); W/O Aux. Cooler; W/2WD .....	B64227
<b>V-6 4.3 L ENG.</b>		<b>V-8 6.2 L DIESEL ENG.</b>	
Inlet (Upper) .....	B64267	Aux. Cooler Inlet (Driver Side) .....	B64251
Outlet (Lower) .....	B64268	Aux. Cooler Outlet (Pass. Side) .....	B64252
<b>V-8 5.0 L ENG.</b>		Inlet (Upper); W/O Aux. Cooler .....	B64254
Inlet (Lower); W/2WD .....	B64217	Outlet (Lower); W/O Aux. Cooler .....	B64255
Inlet (Upper); W/4WD .....	B64218	<b>1988</b>	
Outlet (Lower); W/4WD .....	B64228	<b>V-6 4.3 L ENG.</b>	
Outlet (Upper); W/2WD .....	B64227	Inlet (Upper); Late .....	B64267
<b>V-8 5.7 L ENG.</b>		Outlet (Lower); Late .....	B64268
Aux. Cooler Inlet (Driver Side); W/4WD .....	B64269	<b>V-8 5.0 L ENG.</b>	
Aux. Cooler Outlet (Pass. Side); W/4WD .....	B64270	Inlet (Lower); W/2WD; Late .....	B64217
Inlet (Lower); W/O Aux. Cooler; W/2WD .....	B64216	Inlet (Upper); W/4WD; Late .....	B64218
Inlet (Upper); W/O Aux. Cooler; W/4WD .....	B64247	Outlet (Lower); W/4WD; Late .....	B64228
Outlet (Lower); W/O Aux. Cooler; W/4WD .....	B64248	Outlet (Upper); W/2WD; Late .....	B64227
Outlet (Upper); W/O Aux. Cooler; W/2WD .....	B64226	<b>V-8 5.7 L ENG.</b>	
<b>V-8 6.2 L DIESEL ENG.; V-8 6.5 L DIESEL ENG.</b>		Aux. Cooler Inlet (Driver Side); W/4WD .....	B64269
Aux. Cooler Inlet (Driver Side) .....	B64253	Aux. Cooler Outlet (Pass. Side); W/4WD .....	B64273
Aux. Cooler Outlet (Pass. Side) .....	B64252	Inlet (Lower); W/O Aux. Cooler; W/2WD .....	B64217
Inlet (Upper); W/O Aux. Cooler .....	B64254	Inlet (Upper); W/O Aux. Cooler; W/4WD .....	B64218
Outlet (Lower); W/O Aux. Cooler .....	B64255	Outlet (Lower); W/O Aux. Cooler; W/4WD .....	B64228
<b>V-8 7.4 L ENG.</b>		Outlet (Upper); W/O Aux. Cooler; W/2WD .....	B64227
Inlet (Lower); W/O Aux. Cooler; Exc. H.D. ....	B64256	<b>V-8 6.2 L DIESEL ENG.</b>	
Outlet (Upper); W/O Aux. Cooler; Exc. H.D. ....	B64257	Aux. Cooler Inlet (Driver Side); W/2WD .....	B64251
<b>1991</b>		Aux. Cooler Inlet (Driver Side); W/4WD .....	B64251
<b>V-6 4.3 L ENG.</b>		Aux. Cooler Outlet (Pass. Side); W/2WD .....	B64252
Inlet (Upper) .....	B64267	Aux. Cooler Outlet (Pass. Side); W/4WD; 2nd Design .....	B64252
Outlet (Lower) .....	B64268	Aux. Cooler Outlet (Pass. Side); W/4WD; 2nd Design .....	B64252
<b>V-8 5.0 L ENG.</b>		Inlet (Upper); W/O Aux. Cooler .....	B64254
Inlet (Lower); W/2WD .....	B64217	Outlet (Lower); W/O Aux. Cooler .....	B64255
Inlet (Upper); W/4WD .....	B64218	<b>EXPRESS</b>	
Outlet (Lower); W/4WD .....	B64228	<b>2002-1996</b>	
Outlet (Upper); W/2WD .....	B64227	<b>V-6 4.3 L ENG.</b>	
<b>V-8 5.7 L ENG.</b>		Inlet & Outlet Assy. ....	
Aux. Cooler Inlet (Driver Side); W/4WD .....	B64269	<b>V-8 5.0 L ENG.; V-8 5.7 L ENG.</b>	
Aux. Cooler Outlet (Pass. Side); W/4WD .....	B64273	Inlet (Upper) .....	B64233
Inlet (Lower); W/O Aux. Cooler; W/2WD; Exc. H.D. ....	B64217	Outlet (Lower) .....	B64234
Inlet (Upper); W/O Aux. Cooler; W/2WD; H.D. ....	B64216	<b>G SERIES VAN</b>	
Inlet (Upper); W/O Aux. Cooler; W/4WD; Exc. H.D. ....	B64218	<b>1998-1997</b>	
Inlet (Upper); W/O Aux. Cooler; W/4WD; H.D. ....	B64247	<b>V-6 4.3 L ENG.</b>	
Outlet (Lower); W/O Aux. Cooler; W/2WD; H.D. ....	B64226	Inlet & Outlet Assy. ....	
Outlet (Lower); W/O Aux. Cooler; W/4WD; Exc. H.D. ....	B64228	<b>V-8 5.0 L ENG.; V-8 5.7 L ENG.</b>	
Outlet (Lower); W/O Aux. Cooler; W/4WD; H.D. ....	B64248	Inlet (Upper) .....	B64233
Outlet (Upper); W/O Aux. Cooler; W/2WD; Exc. H.D. ....	B64227	Outlet (Lower) .....	B64234
<b>V-8 6.2 L DIESEL ENG.</b>		<b>1996-1994</b>	
Aux. Cooler Inlet (Driver Side) .....	B64251	<b>V-6 4.3 L ENG.</b>	
Aux. Cooler Outlet (Pass. Side) .....	B64252	Inlet (Lower) .....	
Inlet (Upper); W/O Aux. Cooler .....	B64254	Outlet (Upper) .....	
Outlet (Lower); W/O Aux. Cooler .....	B64255	<b>V-8 5.0 L ENG.; V-8 5.7 L ENG.</b>	
<b>1990-1989</b>		Inlet (Upper) .....	
<b>V-6 4.3 L ENG.</b>		Outlet (Lower) .....	
Inlet (Upper) .....	B64267	<b>1996-1994</b>	
Outlet (Lower) .....	B64268	<b>V-6 4.3 L ENG.</b>	
<b>V-8 5.0 L ENG.</b>		Inlet (Lower) .....	
Inlet (Lower); W/2WD .....	B64217	Outlet (Upper) .....	
Inlet (Upper); W/4WD .....	B64218	<b>V-8 5.0 L ENG.; V-8 5.7 L ENG.</b>	
Outlet (Lower); W/4WD .....	B64228	Inlet Hose (Upper) To Oil Filter Adapter .....	
Outlet (Upper); W/2WD .....	B64227	Outlet Hose (Lower) To Oil Filter Adapter .....	
<b>V-8 6.5 L DIESEL ENG.</b>		<b>V-8 6.5 L DIESEL ENG.</b>	
Inlet (Lower) .....	B64202	Inlet (Lower) .....	
Outlet (Upper) .....	B64203	Outlet (Upper) .....	

See Pages 11 - 114 for Transmission Oil Cooler Applications.

## Engine Oil Cooler Assemblies for Light Trucks

Application	Assembly Number	Application	Assembly Number
<b>CHEVROLET - Continued</b>		<b>CHEVROLET - Continued</b>	
<b>G SERIES VAN - Continued</b>		<b>S SERIES PICKUP - Continued</b>	
<b>1993-1992</b>		<b>1989-1988</b>	
<b>V-6 4.3 L ENG.</b>		<b>V-6 4.3 L ENG.</b>	
Inlet (Lower); W/Front A.C.....	B64237	Inlet & Outlet Assy. From Oil Filter to Rad.; W/4WD.....	B64260
Inlet (Upper); W/O Front A.C.....	B64235	Inlet & Outlet Assy. To Remote Oil Filter; W/4WD.....	B64219
Outlet (Upper); W/Front A.C.....	B64238	Inlet (Lower); W/2WD.....	B64263
Outlet (Upper); W/O Front A.C.....	B64236	Outlet (Upper); W/2WD.....	B64264
<b>V-8 5.0 L ENG.; V-8 5.7 L ENG.</b>		<b>SUBURBAN</b>	
Inlet Hose (Upper) To Oil Filter Adapter.....	A64002	<b>1999-1998</b>	
Outlet Hose (Lower) To Oil Filter Adapter.....	A64002	<b>V-8 5.7 L ENG.</b>	
<b>V-8 6.2 L DIESEL ENG.</b>		Inlet (Lower); W/2WD.....	
Inlet Hose (Lower) From Eng. Block.....	B64275	Inlet (Lower); W/4WD.....	
Outlet Hose (Upper) From Eng. Block.....	B64276	Outlet (Upper); W/2WD.....	
<b>1991-1985</b>		Outlet (Upper); W/4WD.....	
<b>V-6 4.3 L ENG.</b>		<b>V-8 7.4 L ENG.</b>	
Inlet (Lower).....	B64235	Inlet (Lower).....	
Outlet (Upper).....	B64236	Outlet (Upper).....	
<b>V-8 5.0 L ENG.; V-8 5.7 L ENG.</b>		<b>1997</b>	
Inlet Hose (Upper) To Oil Filter Adapter.....	A64000	<b>V-8 5.7 L ENG.</b>	
Outlet Hose (Lower) To Oil Filter Adapter.....	A64001	Inlet (Lower); W/2WD.....	
<b>V-8 6.2 L DIESEL ENG.</b>		Inlet (Lower); W/4WD.....	
Inlet (Upper).....	B64206	Outlet (Upper); W/2WD.....	
Outlet (Lower).....	B64207	Outlet (Upper); W/4WD.....	
<b>R &amp; V SERIES PICKUP</b>		<b>V-8 6.5 L DIESEL ENG.</b>	
<b>1991-1988</b>		Inlet (Driver Side); W/1/2" Tubing.....	
<b>V-8 5.7 L ENG.; V-8 7.4 L ENG.</b>		Outlet (Pass. Side); W/1/2" Tubing.....	
Aux. Cooler Inlet (Pass. Side); W/2WD.....	B64265	<b>V-8 7.4 L ENG.</b>	
Aux. Cooler Inlet (Pass. Side); W/4WD.....	B64243	Inlet (Lower).....	
Aux. Cooler Outlet (Driver Side); W/2WD.....	B64266	Outlet (Upper).....	
Aux. Cooler Outlet (Driver Side); W/4WD.....	B64244	<b>1996</b>	
<b>V-8 6.2 L DIESEL ENG.</b>		<b>V-8 5.7 L ENG.</b>	
Inlet Hose (Upper) From Eng. Block.....	B64277	Inlet (Lower); W/2WD.....	
Outlet Hose (Lower) From Eng. Block.....	B64278	Inlet (Lower); W/4WD.....	
<b>S SERIES PICKUP</b>		Outlet (Upper); W/2WD.....	
<b>2004-1996</b>		Outlet (Upper); W/4WD.....	
<b>V-6 4.3 L ENG.</b>		<b>V-8 6.5 L DIESEL ENG.</b>	
Inlet & Outlet Assy.; W/2WD.....	B64224	Inlet (Driver Side).....	
Inlet & Outlet Assy. From Oil Filter to Rad.; W/4WD.....	B64225	Outlet (Pass. Side).....	
Inlet & Outlet Assy. To Eng. Block Adapter; W/4WD.....	B64220	<b>V-8 7.4 L ENG.</b>	
<b>1995-1994</b>		Inlet (Lower).....	
<b>V-6 4.3 L ENG.</b>		Outlet (Upper).....	
Inlet & Outlet Assy. From Oil Filter to Rad.; W/4WD.....	B64223	<b>1995</b>	
Inlet & Outlet Assy. To Eng. Block Adapter; W/4WD.....	B64221	<b>V-8 5.7 L ENG.</b>	
Inlet (Upper); W/2WD.....	B64204	Inlet (Lower); W/2WD.....	
Outlet (Lower); W/2WD.....	B64205	Inlet (Upper); W/4WD.....	
<b>1993-1992</b>		Outlet (Lower); W/4WD.....	
<b>V-6 4.3 L ENG.</b>		<b>V-8 6.5 L DIESEL ENG.</b>	
Inlet & Outlet Assy. From Oil Filter to Rad.; W/4WD; Eng. VIN W.....	B64261	Inlet (Driver Side).....	
Inlet & Outlet Assy. From Oil Filter to Rad.; W/4WD; Eng. VIN Z.....	B64260	Outlet (Pass. Side).....	
Inlet & Outlet Assy. To Remote Oil Filter; W/4WD.....	B64219	<b>V-8 7.4 L ENG.</b>	
Inlet (Lower); W/2WD.....	B64263	Inlet (Lower); W/O Aux. Cooler.....	
Outlet (Upper); W/2WD; Eng. VIN Z.....	B64264	Outlet (Upper); W/O Aux. Cooler.....	
<b>1991-1990</b>		<b>1994</b>	
<b>V-6 4.3 L ENG.</b>		<b>V-8 5.7 L ENG.</b>	
Inlet & Outlet Assy. From Oil Filter to Rad.; W/4WD.....	B64261	Inlet (Lower); W/2WD.....	
Inlet & Outlet Assy. To Remote Oil Filter; W/4WD.....	B64219	Inlet (Upper); W/4WD.....	
Inlet (Lower); W/2WD.....	B64263	Outlet (Lower); W/4WD.....	
Outlet (Upper); W/2WD.....	B64264	Outlet (Upper); W/2WD.....	
<b>V-8 7.4 L ENG.</b>		<b>V-8 7.4 L ENG.</b>	
Inlet (Lower); W/O Aux. Cooler.....	B64212	Inlet (Lower); W/O Aux. Cooler.....	
Outlet (Upper); W/O Aux. Cooler.....	B64213	Outlet (Upper); W/O Aux. Cooler.....	

See Pages 11 - 114 for Transmission Oil Cooler Applications.

## Engine Oil Cooler Assemblies for Light Trucks

Application	Assembly Number	Application	Assembly Number
<b>CHEVROLET - Continued</b>		<b>GMC</b>	
<b>SUBURBAN - Continued</b>		<p>IMPORTANT: PLEASE NOTE. To select correct replacement parts, it may be necessary to identify the code character for the engine by looking at the VIN (Vehicle Identification Number) located on the dash panel. For 1981 and newer cars, refer to the 8th digit of VIN for the correct engine code. For 1980 and older cars, refer to the 5th digit of VIN for the correct engine code.</p>	
<b>1993-1992</b>		<b>C &amp; K SERIES PICKUP</b>	
<b>V-8 5.7 L ENG.</b>		<b>2000</b>	
Aux. Cooler Inlet (Pass. Side); W/4WD .....	B64270	<b>V-8 5.7 L ENG.</b>	
Aux. Cooler Outlet (Driver Side); W/4WD .....	B64269	Inlet (Lower); W/2WD .....	B64229
Inlet (Lower); W/O Aux. Cooler; W/2WD .....	B64216	Inlet (Lower); W/4WD .....	B64210
Inlet (Upper); W/O Aux. Cooler; W/4WD .....	B64247	Outlet (Upper); W/2WD .....	B64230
Outlet (Lower); W/O Aux. Cooler; W/4WD .....	B64248	Outlet (Upper); W/4WD .....	B64211
Outlet (Upper); W/O Aux. Cooler; W/2WD .....	B64226	<b>V-8 7.4 L ENG.</b>	
<b>V-8 7.4 L ENG.</b>		Inlet (Lower) .....	B64231
Inlet (Lower); W/O Aux. Cooler .....	B64256	Outlet (Upper); 3500HD .....	B64274
Outlet (Upper); W/O Aux. Cooler .....	B64257	Outlet (Upper); Exc. 3500HD .....	B64232
<b>1991-1988</b>		<b>1999</b>	
<b>V-8 5.7 L ENG.; V-8 7.4 L ENG.</b>		<b>V-8 5.0 L ENG.</b>	
Aux. Cooler Inlet (Pass. Side); W/2WD .....	B64265	Inlet (Lower); W/140A. Alt.; W/2WD .....	B64229
Aux. Cooler Inlet (Pass. Side); W/4WD .....	B64243	Inlet (Lower); W/140A. Alt.; W/4WD .....	B64210
Aux. Cooler Outlet (Driver Side); W/2WD .....	B64266	Outlet (Upper); W/140A. Alt.; W/2WD .....	B64230
Aux. Cooler Outlet (Driver Side); W/4WD .....	B64244	Outlet (Upper); W/140A. Alt.; W/4WD .....	B64211
<b>V-8 6.2 L DIESEL ENG.</b>		<b>V-8 5.7 L ENG.</b>	
Inlet Hose (Upper) From Eng. Block .....	B64277	Inlet (Lower); W/2WD .....	B64229
Outlet Hose (Lower) From Eng. Block .....	B64278	Inlet (Lower); W/4WD .....	B64210
<b>TAHOE</b>		Outlet (Upper); W/2WD .....	B64230
<b>2000-1998</b>		Outlet (Upper); W/4WD .....	B64211
<b>V-8 5.7 L ENG.</b>		<b>V-8 7.4 L ENG.</b>	
Inlet (Lower); W/2WD .....	B64229	Inlet (Lower) .....	B64231
Inlet (Lower); W/4WD .....	B64210	Outlet (Upper); 3500HD .....	B64274
Outlet (Upper); W/2WD .....	B64230	Outlet (Upper); Exc. 3500HD .....	B64232
Outlet (Upper); W/4WD .....	B64211	<b>1998</b>	
<b>1997</b>		<b>V-6 4.3 L ENG.</b>	
<b>V-8 5.7 L ENG.</b>		Inlet (Upper) .....	B64249
Inlet (Lower); W/2WD .....	B64229	Outlet (Lower) .....	B64250
Inlet (Lower); W/4WD .....	B64210	<b>V-8 5.0 L ENG.</b>	
Outlet (Upper); W/2WD .....	B64230	Inlet (Lower); W/140A. Alt.; W/2WD .....	B64229
Outlet (Upper); W/4WD .....	B64211	Inlet (Lower); W/140A. Alt.; W/4WD .....	B64210
<b>V-8 6.5 L DIESEL ENG.</b>		Outlet (Upper); W/140A. Alt.; W/2WD .....	B64230
Inlet (Driver Side); W/1/2" Tubing .....	B64214	Outlet (Upper); W/140A. Alt.; W/4WD .....	B64211
Outlet (Pass. Side); W/1/2" Tubing .....	B64215	<b>V-8 5.7 L ENG.</b>	
<b>1996</b>		Inlet (Lower); W/2WD .....	B64229
<b>V-8 5.7 L ENG.</b>		Inlet (Lower); W/4WD .....	B64210
Inlet (Lower); W/2WD .....	B64229	Outlet (Upper); W/2WD .....	B64230
Inlet (Lower); W/4WD .....	B64210	Outlet (Upper); W/4WD .....	B64211
Outlet (Upper); W/2WD .....	B64230	<b>V-8 7.4 L ENG.</b>	
Outlet (Upper); W/4WD .....	B64211	Inlet (Lower) .....	B64231
<b>V-8 6.5 L DIESEL ENG.</b>		Outlet (Upper); 3500HD .....	B64274
Inlet (Driver Side) .....	B64214	Outlet (Upper); Exc. 3500HD .....	B64232
Outlet (Pass. Side) .....	B64215	<b>1997</b>	
<b>1995</b>		<b>V-6 4.3 L ENG.</b>	
<b>V-8 5.7 L ENG.</b>		Inlet (Upper) .....	B64249
Inlet (Lower); W/2WD .....	B64245	Outlet (Lower) .....	B64250
Inlet (Upper); W/4WD .....	B64208	<b>V-8 5.0 L ENG.</b>	
Outlet (Lower); W/4WD .....	B64209	Inlet (Lower); W/140A. Alt.; W/2WD .....	B64229
Outlet (Upper); W/2WD .....	B64246	Inlet (Lower); W/140A. Alt.; W/4WD .....	B64210
<b>V-8 6.5 L DIESEL ENG.</b>		Outlet (Upper); W/140A. Alt.; W/2WD .....	B64230
Inlet (Driver Side) .....	B64214	Outlet (Upper); W/140A. Alt.; W/4WD .....	B64211
Outlet (Pass. Side) .....	B64215	<b>V-8 5.7 L ENG.</b>	
<b>1994</b>		Inlet (Lower); W/2WD .....	B64229
<b>V-8 5.7 L ENG.</b>		Inlet (Lower); W/4WD .....	B64210
Inlet (Lower); W/2WD .....	B64245	Outlet (Upper); W/2WD .....	B64230
Inlet (Upper); W/4WD .....	B64208	Outlet (Upper); W/4WD .....	B64211
Outlet (Lower); W/4WD .....	B64209	<b>V-8 6.5 L DIESEL ENG.</b>	
Outlet (Upper); W/2WD .....	B64246	Inlet (Driver Side); W/1/2" Tubing; 3500HD .....	B64258
<b>V-8 6.5 L DIESEL ENG.</b>		Inlet (Driver Side); W/1/2" Tubing; Exc. 3500HD .....	B64214
Inlet (Driver Side) .....	B64214		
Outlet (Pass. Side) .....	B64215		

See Pages 11 - 114 for Transmission Oil Cooler Applications.

## Engine Oil Cooler Assemblies for Light Trucks

Application	Assembly Number	Application	Assembly Number
<b>GMC - Continued</b>		<b>GMC - Continued</b>	
<b>C &amp; K SERIES PICKUP - Continued</b>		<b>C &amp; K SERIES PICKUP - Continued</b>	
<b>1997 - Continued</b>		<b>1994 - Continued</b>	
<b>V-8 6.5 L DIESEL ENG. - Continued</b>		<b>V-8 5.7 L ENG. - Continued</b>	
Outlet (Pass. Side); W/1/2" Tubing; 3500HD.....	B64259	Inlet (Upper); W/4WD; Exc. Chassis Cab.....	B64218
Outlet (Pass. Side); W/1/2" Tubing; Exc. 3500HD.....	B64215	Inlet (Upper); W/4WD; W/Chassis Cab.....	B64208
<b>V-8 7.4 L ENG.</b>		Outlet (Lower); W/4WD; Exc. Chassis Cab.....	B64228
Inlet (Lower).....	B64231	Outlet (Lower); W/4WD; W/Chassis Cab.....	B64209
Outlet (Upper); 3500HD.....	B64274	Outlet (Upper); W/2WD; Exc. Chassis Cab.....	B64227
Outlet (Upper); Exc. 3500HD.....	B64232	Outlet (Upper); W/2WD; W/Chassis Cab.....	B64246
<b>1996</b>		<b>V-8 6.5 L DIESEL ENG.</b>	
<b>V-6 4.3 L ENG.</b>		Aux. Cooler Inlet (Pass. Side); Exc. 3500HD.....	B64253
Inlet (Upper).....	B64249	Aux. Cooler Outlet (Driver Side); Exc. 3500HD.....	B64252
Outlet (Lower).....	B64250	<b>V-8 7.4 L ENG.</b>	
<b>V-8 5.0 L ENG.</b>		Inlet (Lower); W/O Aux. Cooler.....	B64212
Inlet (Lower); W/140A. Alt.; W/2WD.....	B64229	Outlet (Upper); W/O Aux. Cooler.....	B64213
Inlet (Lower); W/140A. Alt.; W/4WD.....	B64210	<b>1993-1992</b>	
Outlet (Upper); W/140A. Alt.; W/2WD.....	B64230	<b>V-6 4.3 L ENG.</b>	
Outlet (Upper); W/140A. Alt.; W/4WD.....	B64211	Inlet (Upper).....	B64267
<b>V-8 5.7 L ENG.</b>		Outlet (Lower).....	B64268
Inlet (Lower); W/2WD.....	B64229	<b>V-8 5.0 L ENG.</b>	
Inlet (Lower); W/4WD.....	B64210	Inlet (Lower); W/2WD.....	B64217
Outlet (Upper); W/2WD.....	B64230	Inlet (Upper); W/4WD.....	B64218
Outlet (Upper); W/4WD.....	B64211	Outlet (Lower); W/4WD.....	B64228
<b>V-8 6.5 L DIESEL ENG.</b>		Outlet (Upper); W/2WD.....	B64227
Inlet (Driver Side); 3500HD.....	B64258	<b>V-8 5.7 L ENG.</b>	
Inlet (Driver Side); Exc. 3500HD.....	B64214	Aux. Cooler Inlet (Driver Side); W/4WD.....	B64269
Outlet (Pass. Side); 3500HD.....	B64259	Aux. Cooler Outlet (Pass. Side); W/4WD.....	B64270
Outlet (Pass. Side); Exc. 3500HD.....	B64215	Inlet (Lower); W/O Aux. Cooler; W/2WD.....	B64216
<b>V-8 7.4 L ENG.</b>		Inlet (Upper); W/O Aux. Cooler; W/4WD.....	B64247
Inlet (Lower).....	B64231	Outlet (Lower); W/O Aux. Cooler; W/4WD.....	B64248
Outlet (Upper); 3500HD.....	B64274	Outlet (Upper); W/O Aux. Cooler; W/2WD.....	B64226
Outlet (Upper); Exc. 3500HD.....	B64232	<b>V-8 6.2 L DIESEL ENG.; V-8 6.5 L DIESEL ENG.</b>	
<b>1995</b>		Aux. Cooler Inlet (Driver Side).....	B64253
<b>V-6 4.3 L ENG.</b>		Aux. Cooler Outlet (Pass. Side).....	B64252
Inlet (Upper).....	B64271	Inlet (Upper); W/O Aux. Cooler.....	B64254
Outlet (Lower).....	B64272	Outlet (Lower); W/O Aux. Cooler.....	B64255
<b>V-8 5.0 L ENG.</b>		<b>V-8 7.4 L ENG.</b>	
Inlet (Lower); W/2WD.....	B64217	Inlet (Lower); W/O Aux. Cooler; Exc. H.D.....	B64256
Inlet (Upper); W/4WD.....	B64218	Outlet (Upper); W/O Aux. Cooler; Exc. H.D.....	B64257
Outlet (Lower); W/4WD.....	B64228	<b>1991</b>	
Outlet (Upper); W/2WD.....	B64227	<b>V-6 4.3 L ENG.</b>	
<b>V-8 5.7 L ENG.</b>		Inlet (Upper).....	B64267
Inlet (Lower); W/2WD.....	B64245	Outlet (Lower).....	B64268
Inlet (Upper); W/4WD.....	B64208	<b>V-8 5.0 L ENG.</b>	
Outlet (Lower); W/4WD.....	B64209	Inlet (Lower); W/2WD.....	B64217
Outlet (Upper); W/2WD.....	B64246	Inlet (Upper); W/4WD.....	B64218
<b>V-8 6.5 L DIESEL ENG.</b>		Outlet (Lower); W/4WD.....	B64228
Inlet (Driver Side); 3500HD.....	B64258	Outlet (Upper); W/2WD.....	B64227
Inlet (Driver Side); Exc. 3500HD.....	B64214	<b>V-8 5.7 L ENG.</b>	
Outlet (Pass. Side); 3500HD.....	B64259	Aux. Cooler Inlet (Driver Side); W/4WD.....	B64269
Outlet (Pass. Side); Exc. 3500HD.....	B64215	Aux. Cooler Outlet (Pass. Side); W/4WD.....	B64273
<b>V-8 7.4 L ENG.</b>		Inlet (Lower); W/O Aux. Cooler; W/2WD; Exc. H.D.....	B64217
Inlet (Lower); W/O Aux. Cooler.....	B64212	Inlet (Upper); W/O Aux. Cooler; W/2WD; H.D.....	B64216
Outlet (Upper); W/O Aux. Cooler.....	B64213	Inlet (Upper); W/O Aux. Cooler; W/4WD; Exc. H.D.....	B64218
<b>1994</b>		Inlet (Upper); W/O Aux. Cooler; W/4WD; H.D.....	B64247
<b>V-6 4.3 L ENG.</b>		Outlet (Lower); W/O Aux. Cooler; W/2WD; H.D.....	B64226
Inlet (Upper).....	B64271	Outlet (Lower); W/O Aux. Cooler; W/4WD; Exc. H.D.....	B64228
Outlet (Lower).....	B64272	Outlet (Lower); W/O Aux. Cooler; W/4WD; H.D.....	B64248
<b>V-8 5.0 L ENG.</b>		Outlet (Upper); W/O Aux. Cooler; W/2WD; Exc. H.D.....	B64227
Inlet (Lower); W/2WD.....	B64217	<b>V-8 6.2 L DIESEL ENG.</b>	
Inlet (Upper); W/4WD.....	B64218	Aux. Cooler Inlet (Driver Side).....	B64251
Outlet (Lower); W/4WD.....	B64228	Aux. Cooler Outlet (Pass. Side).....	B64252
Outlet (Upper); W/2WD.....	B64227	Inlet (Upper); W/O Aux. Cooler.....	B64254
<b>V-8 5.7 L ENG.</b>		Outlet (Lower); W/O Aux. Cooler.....	B64255
Inlet (Lower); W/2WD; Exc. Chassis Cab.....	B64217	<b>1990-1989</b>	
Inlet (Lower); W/2WD; W/Chassis Cab.....	B64245	<b>V-6 4.3 L ENG.</b>	
		Inlet (Upper).....	
		B64267	

See Pages 11 - 114 for Transmission Oil Cooler Applications.

## Engine Oil Cooler Assemblies for Light Trucks

Application	Assembly Number	Application	Assembly Number
<b>GMC - Continued</b>		<b>GMC - Continued</b>	
<b>C &amp; K SERIES PICKUP - Continued</b>		<b>G SERIES VAN - Continued</b>	
<b>1990-1989 - Continued</b>		<b>1993-1992</b>	
<b>V-6 4.3 L ENG. - Continued</b>		<b>V-6 4.3 L ENG.</b>	
Outlet (Lower) .....	B64268	Inlet (Lower); W/Front A.C. ....	B64237
<b>V-8 5.0 L ENG.</b>		Inlet (Upper); W/O Front A.C. ....	B64235
Inlet (Lower); W/2WD .....	B64217	Outlet (Upper); W/Front A.C. ....	B64238
Inlet (Upper); W/4WD .....	B64218	Outlet (Upper); W/O Front A.C. ....	B64236
Outlet (Lower); W/4WD .....	B64228	<b>V-8 5.0 L ENG.; V-8 5.7 L ENG.</b>	
Outlet (Upper); W/2WD .....	B64227	Inlet Hose (Upper) To Oil Filter Adapter .....	A64002
<b>V-8 5.7 L ENG.</b>		Outlet Hose (Lower) To Oil Filter Adapter .....	A64002
Aux. Cooler Inlet (Driver Side); W/4WD .....	B64269	<b>V-8 6.2 L DIESEL ENG.</b>	
Aux. Cooler Outlet (Pass. Side); W/4WD .....	B64273	Inlet Hose (Lower) From Eng. Block .....	B64275
Inlet (Lower); W/O Aux. Cooler; W/2WD .....	B64217	Outlet Hose (Upper) From Eng. Block .....	B64276
Inlet (Upper); W/O Aux. Cooler; W/4WD .....	B64218	<b>1991-1985</b>	
Outlet (Lower); W/O Aux. Cooler; W/4WD .....	B64228	<b>V-6 4.3 L ENG.</b>	
Outlet (Upper); W/O Aux. Cooler; W/2WD .....	B64227	Inlet (Lower) .....	B64235
<b>V-8 6.2 L DIESEL ENG.</b>		Outlet (Upper) .....	B64236
Aux. Cooler Inlet (Driver Side) .....	B64251	<b>V-8 5.0 L ENG.; V-8 5.7 L ENG.</b>	
Aux. Cooler Outlet (Pass. Side) .....	B64252	Inlet Hose (Upper) To Oil Filter Adapter .....	A64000
Inlet (Upper); W/O Aux. Cooler .....	B64254	Outlet Hose (Lower) To Oil Filter Adapter .....	A64001
Outlet (Lower); W/O Aux. Cooler .....	B64255	<b>V-8 6.2 L DIESEL ENG.</b>	
<b>1988</b>		Inlet (Upper) .....	B64206
<b>V-6 4.3 L ENG.</b>		Outlet (Lower) .....	B64207
Inlet (Upper); Late .....	B64267	<b>JIMMY</b>	
Outlet (Lower); Late .....	B64268	<b>2004-2002</b>	
<b>V-8 5.0 L ENG.</b>		<b>V-6 4.3 L ENG. (CANADA)</b>	
Inlet (Lower); W/2WD; Late .....	B64217	Inlet & Outlet Assy.; W/2WD .....	B64224
Inlet (Upper); W/4WD; Late .....	B64218	Inlet & Outlet Assy. From Oil Filter to Rad.; W/4WD .....	B64225
Outlet (Lower); W/4WD; Late .....	B64228	Inlet & Outlet Assy. To Eng. Block Adapter; W/4WD .....	B64220
Outlet (Upper); W/2WD; Late .....	B64227	<b>2001-1996</b>	
<b>V-8 5.7 L ENG.</b>		<b>V-6 4.3 L ENG.</b>	
Aux. Cooler Inlet (Driver Side); W/4WD .....	B64269	Inlet & Outlet Assy.; W/2WD .....	B64224
Aux. Cooler Outlet (Pass. Side); W/4WD .....	B64273	Inlet & Outlet Assy. From Oil Filter to Rad.; W/4WD .....	B64225
Inlet (Lower); W/O Aux. Cooler; W/2WD .....	B64217	Inlet & Outlet Assy. To Eng. Block Adapter; W/4WD .....	B64220
Inlet (Upper); W/O Aux. Cooler; W/4WD .....	B64218	<b>1995</b>	
Outlet (Lower); W/O Aux. Cooler; W/4WD .....	B64228	<b>V-6 4.3 L ENG.</b>	
Outlet (Upper); W/O Aux. Cooler; W/2WD .....	B64227	Inlet & Outlet Assy. From Oil Filter to Rad.; W/4WD .....	B64223
<b>V-8 6.2 L DIESEL ENG.</b>		Inlet & Outlet Assy. To Eng. Block Adapter; W/4WD .....	B64221
Aux. Cooler Inlet (Driver Side); W/2WD .....	B64251	Inlet (Upper); W/2WD .....	B64204
Aux. Cooler Inlet (Driver Side); W/4WD; 2nd Design .....	B64251	Outlet (Lower); W/2WD .....	B64205
Aux. Cooler Outlet (Pass. Side); W/2WD .....	B64252	<b>1994-1992</b>	
Aux. Cooler Outlet (Pass. Side); W/4WD; 2nd Design .....	B64252	<b>V-6 4.3 L ENG.</b>	
Inlet (Upper); W/O Aux. Cooler .....	B64254	Inlet & Outlet Assy. From Oil Filter to Rad.; W/4WD; Eng. VIN	
Outlet (Lower); W/O Aux. Cooler .....	B64255	W .....	B64261
<b>G SERIES VAN</b>		Inlet & Outlet Assy. From Oil Filter to Rad.; W/4WD; Eng. VIN Z	B64260
<b>1996</b>		Inlet & Outlet Assy. To Remote Oil Filter; W/4WD .....	B64219
<b>V-6 4.3 L ENG.</b>		Inlet (Lower); W/2WD .....	B64263
Inlet (Lower) .....	B64237	Outlet (Upper); W/2WD; Eng. VIN Z .....	B64264
Outlet (Upper) .....	B64238	<b>1991-1990</b>	
<b>V-8 5.7 L ENG.</b>		<b>V-6 4.3 L ENG.</b>	
Inlet Hose (Upper) To Oil Filter Adapter .....	A64002	Inlet & Outlet Assy. From Oil Filter to Rad.; W/4WD .....	B64261
Outlet Hose (Lower) To Oil Filter Adapter .....	A64002	Inlet & Outlet Assy. To Remote Oil Filter; W/4WD .....	B64219
<b>V-8 6.5 L DIESEL ENG.</b>		Inlet (Lower); W/2WD .....	B64263
Inlet (Lower) .....	B64202	Outlet (Upper); W/2WD .....	B64264
Outlet (Upper) .....	B64203	<b>1995-1994</b>	
<b>1995-1994</b>		<b>V-6 4.3 L ENG.</b>	
<b>V-6 4.3 L ENG.</b>		Inlet (Lower) .....	B64237
Inlet (Lower) .....	B64237	Outlet (Upper) .....	B64238
Outlet (Upper) .....	B64238	<b>V-8 5.0 L ENG.; V-8 5.7 L ENG.</b>	
<b>V-8 5.0 L ENG.; V-8 5.7 L ENG.</b>		Inlet Hose (Upper) To Oil Filter Adapter .....	A64002
Inlet Hose (Upper) To Oil Filter Adapter .....	A64002	Outlet Hose (Lower) To Oil Filter Adapter .....	A64002
Outlet Hose (Lower) To Oil Filter Adapter .....	A64002	<b>V-8 6.5 L DIESEL ENG.</b>	
<b>V-8 6.5 L DIESEL ENG.</b>		Inlet (Lower) .....	B64202
Inlet (Lower) .....	B64202	Outlet (Upper) .....	B64203
Outlet (Upper) .....	B64203	<b>1994-1992</b>	
<b>1995-1994</b>		<b>V-6 4.3 L ENG.</b>	
<b>V-6 4.3 L ENG.</b>		Inlet & Outlet Assy. From Oil Filter to Rad.; W/4WD; Eng. VIN	
Inlet (Lower) .....	B64237	W .....	B64261
Outlet (Upper) .....	B64238	Inlet & Outlet Assy. From Oil Filter to Rad.; W/4WD; Eng. VIN Z	B64260
<b>V-8 5.0 L ENG.; V-8 5.7 L ENG.</b>		Inlet & Outlet Assy. To Remote Oil Filter; W/4WD .....	B64219
Inlet Hose (Upper) To Oil Filter Adapter .....	A64002	Inlet (Lower); W/2WD .....	B64263
Outlet Hose (Lower) To Oil Filter Adapter .....	A64002	Outlet (Upper); W/2WD; Eng. VIN Z .....	B64264
<b>V-8 6.5 L DIESEL ENG.</b>		<b>1991-1990</b>	
Inlet (Lower) .....	B64202	<b>V-6 4.3 L ENG.</b>	
Outlet (Upper) .....	B64203	Inlet & Outlet Assy. From Oil Filter to Rad.; W/4WD .....	B64261
<b>1995-1994</b>		Inlet & Outlet Assy. To Remote Oil Filter; W/4WD .....	B64219
<b>V-6 4.3 L ENG.</b>		Inlet (Lower); W/2WD .....	B64263
Inlet (Lower) .....	B64237	Outlet (Upper); W/2WD .....	B64264
Outlet (Upper) .....	B64238	<b>V-8 5.7 L ENG.</b>	
<b>V-8 5.0 L ENG.; V-8 5.7 L ENG.</b>		Aux. Cooler Inlet (Pass. Side) .....	B64243
Inlet Hose (Upper) To Oil Filter Adapter .....	A64002	Aux. Cooler Outlet (Driver Side) .....	B64244
Outlet Hose (Lower) To Oil Filter Adapter .....	A64002	<b>V-8 6.2 L DIESEL ENG.</b>	
<b>V-8 6.5 L DIESEL ENG.</b>		Inlet Hose (Upper) From Eng. Block .....	B64277
Inlet (Lower) .....	B64202	Outlet Hose (Lower) From Eng. Block .....	B64278
Outlet (Upper) .....	B64203		

## Engine Oil Cooler Assemblies for Light Trucks

Application	Assembly Number	Application	Assembly Number
<b>GMC - Continued</b>		<b>GMC - Continued</b>	
<b>JIMMY - Continued</b>		<b>SAVANA</b>	
<b>1989-1988</b>		<b>2002-1996</b>	
<b>V-6 4.3 L ENG.</b>		<b>V-6 4.3 L ENG.</b>	
Inlet & Outlet Assy. From Oil Filter to Rad.; W/4WD.....	B64260	Inlet & Outlet Assy.....	B64262
Inlet & Outlet Assy. To Remote Oil Filter; W/4WD.....	B64219	<b>V-8 5.0 L ENG.; V-8 5.7 L ENG.</b>	
Inlet (Lower); W/2WD.....	B64263	Inlet (Upper).....	B64233
Outlet (Upper); W/2WD.....	B64264	Outlet (Lower).....	B64234
<b>V-8 5.7 L ENG.</b>		<b>SONOMA</b>	
Aux. Cooler Inlet (Pass. Side).....	B64243	<b>2004-1996</b>	
Aux. Cooler Outlet (Driver Side).....	B64244	<b>V-6 4.3 L ENG.</b>	
<b>V-8 6.2 L DIESEL ENG.</b>		Inlet & Outlet Assy.; W/2WD.....	
Inlet Hose (Upper) From Eng. Block.....	B64277	Inlet & Outlet Assy. From Oil Filter to Rad.; W/4WD.....	
Outlet Hose (Lower) From Eng. Block.....	B64278	Inlet & Outlet Assy. To Eng. Block Adapter; W/4WD.....	
<b>R &amp; V SERIES PICKUP</b>		<b>1995-1994</b>	
<b>1991-1988</b>		<b>V-6 4.3 L ENG.</b>	
<b>V-8 5.7 L ENG.; V-8 7.4 L ENG.</b>		Inlet & Outlet Assy. From Oil Filter to Rad.; W/4WD.....	
Aux. Cooler Inlet (Pass. Side); W/2WD.....	B64265	Inlet & Outlet Assy. To Eng. Block Adapter; W/4WD.....	
Aux. Cooler Inlet (Pass. Side); W/4WD.....	B64243	Inlet (Upper); W/2WD.....	
Aux. Cooler Outlet (Driver Side); W/2WD.....	B64266	Outlet (Lower); W/2WD.....	
Aux. Cooler Outlet (Driver Side); W/4WD.....	B64244	<b>1993-1992</b>	
<b>V-8 6.2 L DIESEL ENG.</b>		<b>V-6 4.3 L ENG.</b>	
Inlet Hose (Upper) From Eng. Block.....	B64277	Inlet & Outlet Assy. From Oil Filter to Rad.; W/4WD; Eng. VIN	
Outlet Hose (Lower) From Eng. Block.....	B64278	W.....	
<b>S SERIES PICKUP</b>		Inlet & Outlet Assy. From Oil Filter to Rad.; W/4WD; Eng. VIN Z.....	
<b>1990</b>		Inlet & Outlet Assy. To Remote Oil Filter; W/4WD.....	
<b>V-6 4.3 L ENG.</b>		Inlet (Lower); W/2WD.....	
Inlet & Outlet Assy. From Oil Filter to Rad.; W/4WD.....	B64261	Outlet (Upper); W/2WD; Eng. VIN Z.....	
Inlet & Outlet Assy. To Remote Oil Filter; W/4WD.....	B64219	<b>1991</b>	
Inlet (Lower); W/2WD.....	B64263	<b>V-6 4.3 L ENG.</b>	
Outlet (Upper); W/2WD.....	B64264	Inlet & Outlet Assy. From Oil Filter to Rad.; W/4WD.....	
<b>1989-1988</b>		Inlet & Outlet Assy. To Remote Oil Filter; W/4WD.....	
<b>V-6 4.3 L ENG.</b>		Inlet (Lower); W/2WD.....	
Inlet & Outlet Assy. From Oil Filter to Rad.; W/4WD.....	B64260	Outlet (Upper); W/2WD.....	
Inlet & Outlet Assy. To Remote Oil Filter; W/4WD.....	B64219	<b>SUBURBAN</b>	
Inlet (Lower); W/2WD.....	B64263	<b>1999-1998</b>	
Outlet (Upper); W/2WD.....	B64264	<b>V-8 5.7 L ENG.</b>	
<b>SAFARI</b>		Inlet (Lower); W/2WD.....	
<b>2005-1996</b>		Inlet (Lower); W/4WD.....	
<b>V-6 4.3 L ENG.</b>		Outlet (Upper); W/2WD.....	
Inlet & Outlet Assy.....	B64222	Outlet (Upper); W/4WD.....	
<b>1995</b>		<b>V-8 7.4 L ENG.</b>	
<b>V-6 4.3 L ENG.</b>		Inlet (Lower).....	
Inlet (Upper).....	B64240	Outlet (Upper).....	
Outlet (Lower).....	B64239	<b>1997</b>	
<b>1994</b>		<b>V-8 5.7 L ENG.</b>	
<b>V-6 4.3 L ENG.</b>		Inlet (Lower); W/2WD.....	
Inlet (Upper); W/2WD.....	B64241	Inlet (Lower); W/4WD.....	
Outlet (Lower); W/2WD.....	B64242	Outlet (Upper); W/2WD.....	
<b>1993-1990</b>		Outlet (Upper); W/4WD.....	
<b>V-6 4.3 L ENG.</b>		<b>V-8 6.5 L DIESEL ENG.</b>	
Inlet (Upper); W/2WD.....	B64200	Inlet (Driver Side); W/1/2" Tubing.....	
Outlet (Lower); W/2WD.....	B64201	Outlet (Pass. Side); W/1/2" Tubing.....	
<b>1989-1985</b>		<b>V-8 7.4 L ENG.</b>	
<b>V-6 4.3 L ENG.</b>		Inlet (Lower).....	
Inlet (Upper).....	B64200	Outlet (Upper).....	
Outlet (Lower).....	B64201	<b>1996</b>	
<b>1989-1985</b>		<b>V-8 5.7 L ENG.</b>	
<b>V-6 4.3 L ENG.</b>		Inlet (Lower); W/2WD.....	
Inlet (Upper).....	B64200	Inlet (Lower); W/4WD.....	
Outlet (Lower).....	B64201	Outlet (Upper); W/2WD.....	

See Pages 11 - 114 for Transmission Oil Cooler Applications.

## Engine Oil Cooler Assemblies for Light Trucks

Application	Assembly Number	Application	Assembly Number
<b>GMC - Continued</b>		<b>GMC - Continued</b>	
<b>SUBURBAN - Continued</b>		<b>SYCLONE - Continued</b>	
<b>1996 - Continued</b>		<b>1991</b>	
<b>V-8 5.7 L ENG. - Continued</b>		<b>V-6 4.3 L ENG.</b>	
Outlet (Upper); W/4WD.....	B64211	Inlet & Outlet Assy. From Oil Filter to Rad.; W/4WD.....	B64261
<b>V-8 6.5 L DIESEL ENG.</b>		Inlet & Outlet Assy. To Remote Oil Filter; W/4WD.....	B64219
Inlet (Driver Side).....	B64214	Inlet (Lower); W/2WD.....	B64263
Outlet (Pass. Side).....	B64215	Outlet (Upper); W/2WD.....	B64264
<b>V-8 7.4 L ENG.</b>		<b>TYPHOON</b>	
Inlet (Lower).....	B64231	<b>1993-1992</b>	
Outlet (Upper).....	B64232	<b>V-6 4.3 L ENG.</b>	
<b>1995</b>		Inlet & Outlet Assy. From Oil Filter to Rad.; W/4WD.....	
<b>V-8 5.7 L ENG.</b>		Inlet & Outlet Assy. To Remote Oil Filter; W/4WD.....	
Inlet (Lower); W/2WD.....	B64245	B64260	
Inlet (Upper); W/4WD.....	B64208	B64219	
Outlet (Lower); W/4WD.....	B64209		
Outlet (Upper); W/2WD.....	B64246	<b>YUKON</b>	
<b>V-8 6.5 L DIESEL ENG.</b>		<b>2000-1998</b>	
Inlet (Driver Side).....	B64214	<b>V-8 5.7 L ENG.</b>	
Outlet (Pass. Side).....	B64215	Inlet (Lower); W/2WD.....	
<b>V-8 7.4 L ENG.</b>		Inlet (Lower); W/4WD.....	
Inlet (Lower); W/O Aux. Cooler.....	B64212	Outlet (Upper); W/2WD.....	
Outlet (Upper); W/O Aux. Cooler.....	B64213	Outlet (Upper); W/4WD.....	
<b>1994</b>		<b>1997</b>	
<b>V-8 5.7 L ENG.</b>		<b>V-8 5.7 L ENG.</b>	
Inlet (Lower); W/2WD.....	B64245	Inlet (Lower); W/2WD.....	
Inlet (Upper); W/4WD.....	B64208	Inlet (Lower); W/4WD.....	
Outlet (Lower); W/4WD.....	B64209	Outlet (Upper); W/2WD.....	
Outlet (Upper); W/2WD.....	B64246	Outlet (Upper); W/4WD.....	
<b>V-8 7.4 L ENG.</b>		<b>V-8 6.5 L DIESEL ENG.</b>	
Inlet (Lower); W/O Aux. Cooler.....	B64212	Inlet (Driver Side); W/1/2" Tubing.....	
Outlet (Upper); W/O Aux. Cooler.....	B64213	Outlet (Pass. Side); W/1/2" Tubing.....	
<b>1993-1992</b>		<b>1996</b>	
<b>V-8 5.7 L ENG.</b>		<b>V-8 5.7 L ENG.</b>	
Aux. Cooler Inlet (Pass. Side); W/4WD.....	B64270	Inlet (Lower); W/2WD.....	
Aux. Cooler Outlet (Driver Side); W/4WD.....	B64269	Inlet (Lower); W/4WD.....	
Inlet (Lower); W/O Aux. Cooler; W/2WD.....	B64216	Outlet (Upper); W/2WD.....	
Inlet (Upper); W/O Aux. Cooler; W/4WD.....	B64247	Outlet (Upper); W/4WD.....	
Outlet (Lower); W/O Aux. Cooler; W/4WD.....	B64248	<b>V-8 6.5 L DIESEL ENG.</b>	
Outlet (Upper); W/O Aux. Cooler; W/2WD.....	B64226	Inlet (Driver Side).....	
<b>V-8 7.4 L ENG.</b>		Outlet (Pass. Side).....	
Inlet (Lower); W/O Aux. Cooler.....	B64256	B64214	
Outlet (Upper); W/O Aux. Cooler.....	B64257	B64215	
<b>1991-1988</b>		<b>1995</b>	
<b>V-8 5.7 L ENG.; V-8 7.4 L ENG.</b>		<b>V-8 5.7 L ENG.</b>	
Aux. Cooler Inlet (Pass. Side); W/2WD.....	B64265	Inlet (Lower); W/2WD.....	
Aux. Cooler Inlet (Pass. Side); W/4WD.....	B64243	Inlet (Upper); W/4WD.....	
Aux. Cooler Outlet (Driver Side); W/2WD.....	B64266	Outlet (Lower); W/4WD.....	
Aux. Cooler Outlet (Driver Side); W/4WD.....	B64244	Outlet (Upper); W/2WD.....	
<b>V-8 6.2 L DIESEL ENG.</b>		<b>V-8 6.5 L DIESEL ENG.</b>	
Inlet Hose (Upper) From Eng. Block.....	B64277	Inlet (Driver Side).....	
Outlet Hose (Lower) From Eng. Block.....	B64278	Outlet (Pass. Side).....	
<b>SYCLONE</b>		<b>1994</b>	
<b>1992</b>		<b>V-8 5.7 L ENG.</b>	
<b>V-6 4.3 L ENG.</b>		Inlet (Lower); W/2WD.....	
Inlet & Outlet Assy. From Oil Filter to Rad.; W/4WD; Eng. VIN W.....	B64261	Inlet (Upper); W/4WD.....	
Inlet & Outlet Assy. From Oil Filter to Rad.; W/4WD; Eng. VIN Z	B64260	Outlet (Lower); W/4WD.....	
Inlet & Outlet Assy. To Remote Oil Filter; W/4WD.....	B64219	Outlet (Upper); W/2WD.....	
Inlet (Lower); W/2WD.....	B64263	B64246	
Outlet (Upper); W/2WD; Eng. VIN Z.....	B64264		
		<b>1993-1992</b>	
		<b>V-8 5.7 L ENG.</b>	
		Inlet (Lower); W/O Aux. Cooler.....	
		Outlet (Upper); W/O Aux. Cooler.....	

See Pages 11 - 114 for Transmission Oil Cooler Applications.

## Engine Oil Cooler Assemblies for Light Trucks

Application	Assembly Number	Application	Assembly Number
<b>OLDSMOBILE</b> IMPORTANT: PLEASE NOTE. To select correct replacement parts, it may be necessary to identify the code character for the engine by looking at the VIN (Vehicle Identification Number) located on the dash panel. For 1981 and newer cars, refer to the 8th digit of VIN for the correct engine code. For 1980 and older cars, refer to the 5th digit of VIN for the correct engine code.		<b>OLDSMOBILE - Continued</b>	
<b>BRAVADA</b> <b>2001-1996</b> <b>V-6 4.3 L ENG.</b> Inlet & Outlet Assy.; W/2WD ..... <b>B64224</b> Inlet & Outlet Assy. From Oil Filter to Rad.; W/4WD ..... <b>B64225</b> Inlet & Outlet Assy. To Eng. Block Adapter; W/4WD ..... <b>B64220</b>		<b>BRAVADA - Continued</b> <b>1992</b> <b>V-6 4.3 L ENG.</b> Inlet & Outlet Assy. From Oil Filter to Rad.; W/4WD; Eng. VIN W ..... <b>B64261</b> Inlet & Outlet Assy. From Oil Filter to Rad.; W/4WD; Eng. VIN Z ..... <b>B64260</b> Inlet & Outlet Assy. To Remote Oil Filter; W/4WD ..... <b>B64219</b> Inlet (Lower); W/2WD ..... <b>B64263</b> Outlet (Upper); W/2WD; Eng. VIN Z ..... <b>B64264</b>	
<b>1994-1993</b> <b>V-6 4.3 L ENG.</b> Inlet & Outlet Assy. From Oil Filter to Rad.; W/4WD ..... <b>B64261</b> Inlet & Outlet Assy. To Remote Oil Filter; W/4WD ..... <b>B64219</b> Inlet (Lower); W/2WD ..... <b>B64263</b>		<b>1991</b> <b>V-6 4.3 L ENG.</b> Inlet & Outlet Assy. From Oil Filter to Rad.; W/4WD ..... <b>B64260</b> Inlet & Outlet Assy. To Remote Oil Filter; W/4WD ..... <b>B64219</b> Inlet (Lower); W/2WD ..... <b>B64263</b> Outlet (Upper); W/2WD ..... <b>B64264</b>	

See Pages 11 - 114 for Transmission Oil Cooler Applications.



# Transmission Oil Cooler Assemblies for Passenger Cars & Light Trucks

## Alphabetical Listing

Application	Assembly Number	Hoses & Tubes	Connectors & Fittings	Application	Assembly Number	Hoses & Tubes	Connectors & Fittings
<b>BUICK</b>				<b>BUICK - Continued</b>			
IMPORTANT: PLEASE NOTE. To select correct replacement parts, it may be necessary to identify the code character for the engine by looking at the VIN (Vehicle Identification Number) located on the dash panel. For 1981 and newer cars, refer to the 8th digit of VIN for the correct engine code. For 1980 and older cars, refer to the 5th digit of VIN for the correct engine code.				<b>CENTURY - Continued</b>			
<b>CENTURY</b>				<b>1992</b>			
<b>2003-2000</b>				<b>4-CYL. 2.5 L ENG.; V-6 3.3 L ENG.</b>			
<b>V-6 3.1 L ENG.</b>				Inlet Fitting To Trans. (Upper) .....			A63006
Connector From Rad. ....			②A63065	Inlet From Rad. (Upper).....	∞A63004		
Inlet Fitting To Trans. (Upper).....			A63021	Inlet To Trans. (Upper).....	∞A63004		
Outlet Fitting To Trans. (Lower).....			A63064	Outlet Fitting To Trans. (Lower).....			A63006
Wire Retainer (Connectors & Fittings).....			●A63098	Outlet From Rad. (Lower).....	∞A63004		
				Outlet To Trans. (Lower).....	∞A63004		
				Tube Nut; W/Aux. Cooler.....			⑥A63011
				Tube Nut; W/O Aux. Cooler.....			④A63011
				Tube To Tube (Lower).....	∞A63000		
				Tube To Tube (Upper).....	∞A63000		
<b>1999-1998</b>				<b>1991-1990</b>			
<b>V-6 3.1 L ENG.</b>				<b>4-CYL. 2.5 L ENG.</b>			
Connector From Rad. ....			②A63018	Inlet Fitting To Trans. (Upper).....			A63006
Inlet (Upper) .....	B61239			Inlet From Rad. (Upper).....	∞A63004		
Inlet Fitting To Trans. (Upper).....			A63007	Inlet To Trans. (Upper).....	∞A63004		
Outlet (Lower).....	B61238			Outlet Fitting To Trans. (Lower).....			A63006
Outlet Fitting To Trans. (Lower).....			A63008	Outlet From Rad. (Lower).....	∞A63004		
Wire Retainer (Connectors & Fittings).....			②A63098	Outlet To Trans. (Lower).....	∞A63004		
				Tube Nut; W/Aux. Cooler.....			⑥A63011
				Tube Nut; W/O Aux. Cooler.....			④A63011
				Tube To Tube (Lower).....	∞A63000		
				Tube To Tube (Upper).....	∞A63000		
<b>1997</b>				<b>V-6 3.3 L ENG.</b>			
<b>V-6 3.1 L ENG.</b>				Inlet Fitting To Trans. (Upper).....			
Inlet Fitting To Trans. (Upper).....			A63007	Inlet From Rad. (Upper).....	∞A63004		A63006
Inlet To Trans. (Upper).....	A61031			Inlet To Trans. (Upper).....	∞A63004		
Outlet Fitting To Trans. (Lower).....			A63008	Outlet Fitting To Trans. (Lower);			
Outlet To Trans. (Lower).....	A61030			W/3-Speed Trans. ....			A63006
				Outlet From Rad. (Lower).....	∞A63004		
				Outlet To Trans. (Lower).....	∞A63004		
				Tube Nut; W/Aux. Cooler.....			⑥A63011
				Tube Nut; W/O Aux. Cooler.....			④A63011
				Tube To Tube (Lower).....	∞A63000		
				Tube To Tube (Upper).....	∞A63000		
<b>1996-1994</b>				<b>1989</b>			
<b>4-CYL. 2.2 L ENG.</b>				<b>4-CYL. 2.5 L ENG.</b>			
Inlet Fitting To Trans. (Upper).....			A63006	Inlet Fitting To Trans. (Upper).....			A63006
Inlet To Trans. (Upper).....	A61052			Inlet Hose (Upper).....	∞A63000		
Outlet Fitting To Trans. (Lower).....			A63006	Inlet Tube From Rad. (Upper).....	∞A63004		
Outlet To Trans. (Lower).....	A61052			Inlet Tube To Trans. (Upper).....	∞A63004		
				Outlet Fitting To Trans. (Lower).....			A63006
				Outlet Hose (Lower).....	∞A63000		
				Outlet Tube From Rad. (Lower).....	∞A63004		
				Outlet Tube To Trans. (Lower).....	∞A63004		
				Tube Nut.....			④A63011
<b>V-6 3.1 L ENG.</b>				<b>V-6 2.8 L ENG.; V-6 3.3 L ENG.</b>			
Inlet Fitting To Trans. (Upper).....			A63007	Inlet Fitting To Trans. (Upper).....			A63006
Inlet Hose To Trans. (Upper).....	A61298			Inlet Hose (Upper).....	∞A63000		
Inlet Tube From Rad. (Upper).....		∞A63004		Inlet Tube From Rad. (Upper).....	∞A63004		
Outlet Fitting To Trans. (Lower).....			A63008	Inlet Tube To Trans. (Upper).....	∞A63004		
Outlet Hose To Trans. (Lower).....	A61299			Outlet Fitting To Trans. (Lower).....			A63006
Outlet Tube From Rad. (Lower).....		∞A63004		Outlet Hose (Lower).....	∞A63000		
Tube Nut.....			②A63011	Outlet Tube From Rad. (Lower).....	∞A63004		
				Outlet Tube To Trans. (Lower).....	∞A63004		
				Tube Nut.....			④A63011
<b>1993</b>				<b>1993</b>			
<b>4-CYL. 2.2 L ENG.; V-6 3.3 L ENG.</b>				<b>4-CYL. 2.2 L ENG.; V-6 3.3 L ENG.</b>			
Inlet Fitting To Trans. (Upper).....			A63006	Inlet Fitting To Trans. (Upper).....			A63006
Inlet From Rad. (Upper).....		∞A63004		Inlet From Rad. (Upper).....	∞A63004		
Inlet To Trans. (Upper).....		∞A63004		Inlet To Trans. (Upper).....	∞A63004		
Outlet Fitting To Trans. (Lower).....			A63006	Outlet Fitting To Trans. (Lower).....			A63006
Outlet From Rad. (Lower).....		∞A63004		Outlet From Rad. (Lower).....	∞A63004		
Outlet To Trans. (Lower).....		∞A63004		Outlet To Trans. (Lower).....	∞A63004		
Tube Nut; W/Aux. Cooler.....			⑥A63011	Tube Nut; W/Aux. Cooler.....			⑥A63011
Tube Nut; W/O Aux. Cooler.....			④A63011	Tube Nut; W/O Aux. Cooler.....			④A63011
Tube To Tube (Lower).....		∞A63000		Tube To Tube (Lower).....	∞A63000		
Tube To Tube (Upper).....		∞A63000		Tube To Tube (Upper).....	∞A63004		

② Two Required.  
③ Three Required.

④ Four Required.  
⑤ Five Required.

⑥ Six Required.  
⑦ Seven Required.

∞ Cut To Fit.  
● As Required.

See Pages 1 - 10 for Engine Oil Cooler Applications.

## Transmission Oil Cooler Assemblies for Passenger Cars &amp; Light Trucks

Application	Assembly Number	Hoses & Tubes	Connectors & Fittings	Application	Assembly Number	Hoses & Tubes	Connectors & Fittings
<b>BUICK - Continued</b>				<b>BUICK - Continued</b>			
<b>CENTURY - Continued</b>				<b>ELECTRA - Continued</b>			
<b>1989 - Continued</b>				<b>1989-1988 - Continued</b>			
V-6 2.8 L ENG.; V-6 3.3 L ENG. - Continued				V-8 5.0 L ENG. - Continued			
Tube Nut.....			④A63011	Outlet Hose To Trans. (Lower).....	A61035		
<b>1988</b>				Outlet Tube From Rad. (Lower);			
4-CYL. 2.5 L ENG.				W/Aux. Cooler.....	B61037		
Inlet Fitting To Trans. (Upper).....			A63006	Outlet Tube From Rad. (Lower);			
Inlet Hose (Upper).....	≡A63000			W/O Aux. Cooler.....	B61033		
Inlet Tube From Rad. (Upper).....	≡A63004			Tube Nut.....			●A63011
Inlet Tube To Trans. (Upper).....	≡A63004			<b>1987-1986</b>			
Outlet Fitting To Trans. (Lower).....			A63006	V-6 3.8 L ENG.			
Outlet Hose (Lower).....	≡A63000			Inlet (Upper).....	A61044		
Outlet Tube From Rad. (Lower).....	≡A63004			Inlet Fitting To Trans. (Upper).....			A63006
Outlet Tube To Trans. (Lower).....	≡A63004			Outlet (Lower).....	A61045		
Tube Nut.....			④A63011	<b>V-8 5.0 L ENG.</b>			
<b>V-6 2.8 L ENG.; V-6 3.8 L ENG.</b>				Inlet (Upper).....	A61044		
Inlet Fitting To Trans. (Upper).....			A63006	Inlet Fitting To Trans. (Upper).....			A63006
Inlet Hose (Upper).....	≡A63000			Outlet (Lower).....	A61045		
Inlet Tube From Rad. (Upper).....	≡A63004			Tube Nut.....			●A63011
Inlet Tube To Trans. (Upper).....	≡A63004			<b>LESABRE</b>			
Outlet Fitting To Trans. (Lower);			A63006	<b>2005-2004</b>			
W/3-Speed Trans.....				V-6 3.8 L ENG.			
Outlet Hose (Lower).....	≡A63000			Connector From Rad. ....			②A63018
Outlet Tube From Rad. (Lower).....	≡A63004			Inlet (Upper).....	B61293		
Outlet Tube To Trans. (Lower).....	≡A63004			Outlet (Lower).....	B61292		
Tube Nut.....			④A63011	Wire Retainer (Connectors & Fit-			
<b>ELECTRA</b>				tings).....			④A63098
<b>1990</b>				<b>2003-2000</b>			
V-6 3.8 L ENG.				V-6 3.8 L ENG.			
Inlet Fitting To Trans. (Upper).....			A63006	Connector From Rad. ....			②A63018
Inlet Hose From Rad. (Upper);				Inlet (Upper).....	B61293		
W/Aux. Cooler.....	B61036			Inlet Fitting To Trans. (Upper).....			A63021
Inlet Tube From Rad. (Upper);				Outlet (Lower).....	B61292		
W/O Aux. Cooler.....	B61032			Outlet Fitting To Trans. (Lower).....			A63064
Inlet Tube To Trans. (Upper).....	A61034			Wire Retainer (Connectors & Fit-			④A63098
Outlet Hose To Trans. (Lower);	A61035			tings).....			
W/Aux. Cooler.....	B61037			<b>1999-1998</b>			
Outlet Tube From Rad. (Lower);				V-6 3.8 L ENG.			
W/O Aux. Cooler.....	B61033			Inlet Fitting To Trans. (Upper).....			A63007
Tube Nut.....			●A63011	Inlet From Rad. (Upper).....	B61112		
Tube To Tube (Lower).....				Outlet From Rad. (Lower).....	B61111		
Tube To Tube (Upper).....			≡A63000	<b>1997</b>			
			≡A63000	V-6 3.8 L ENG.			
<b>1989-1988</b>				Inlet Fitting To Trans. (Upper).....			A63007
V-6 3.8 L ENG.				Inlet From Rad. (Upper); Feb. 18 &			
Inlet Fitting To Trans. (Upper).....			A63006	Older.....	B61241		
Inlet Hose From Rad. (Upper);				Inlet From Rad. (Upper); Feb. 19 &			
W/Aux. Cooler.....	B61036			Newer.....	B61112		
Inlet Tube From Rad. (Upper);				Outlet Fitting To Trans. (Lower).....			A63008
W/O Aux. Cooler.....	B61032			Outlet From Rad. (Lower); Feb. 18			
Inlet Tube To Trans. (Upper).....	A61034			& Older.....	B61009		
Outlet Hose To Trans. (Lower).....	A61035			Outlet From Rad. (Lower); Feb. 19			
Outlet Tube From Rad. (Lower);				& Newer.....	B61111		
W/Aux. Cooler.....	B61037			<b>1996</b>			
Outlet Tube From Rad. (Lower);				V-6 3.8 L ENG.			
W/O Aux. Cooler.....	B61033			Inlet Fitting To Trans. (Upper).....			A63007
Tube Nut.....			●A63011	Inlet From Rad. (Upper).....	B61241		
Tube To Tube (Lower).....				Outlet Fitting To Trans. (Lower).....			A63008
Tube To Tube (Upper).....			≡A63000	Outlet From Rad. (Lower).....	B61009		
			≡A63000	<b>1996</b>			
<b>V-8 5.0 L ENG.</b>				V-6 3.8 L ENG.			
Inlet Fitting To Trans. (Upper).....			A63006	Inlet Fitting To Trans. (Upper).....			A63007
Inlet Hose From Rad. (Upper);				Inlet From Rad. (Upper).....	B61241		
W/Aux. Cooler.....	B61036			Outlet Fitting To Trans. (Lower).....			A63008
Inlet Hose From Rad. (Upper);				Outlet From Rad. (Lower).....	B61009		
W/O Aux. Cooler.....							
Inlet Tube From Rad. (Upper);							
W/O Aux. Cooler.....	B61032						
Inlet Tube To Trans. (Upper).....	A61034						

② Two Required.  
③ Three Required.

④ Four Required.  
⑤ Five Required.

⑥ Six Required.  
⑦ Seven Required.

≡ Cut To Fit.  
● As Required.

See Pages 1 - 10 for Engine Oil Cooler Applications.

## Transmission Oil Cooler Assemblies for Passenger Cars & Light Trucks

Application	Assembly Number	Hoses & Tubes	Connectors & Fittings	Application	Assembly Number	Hoses & Tubes	Connectors & Fittings
<b>BUICK - Continued</b>				<b>BUICK - Continued</b>			
<b>LESABRE - Continued</b>				<b>LESABRE - Continued</b>			
<b>1995-1994</b>				<b>1987-1986</b>			
<b>V-6 3.8 L ENG.</b>				<b>V-6 3.8 L ENG.; V-8 5.0 L ENG.</b>			
Aux. Cooler Supply From Rad. (Upper) .....	A61271			Inlet (Upper) .....	A61044		A63006
Inlet Fitting To Trans. (Upper) .....			A63007	Inlet Fitting To Trans. (Upper) .....			
Inlet From Rad. (Upper); W/Aux. Cooler .....	B61110			Outlet (Lower) .....	A61045		
Inlet From Rad. (Upper); W/O Aux. Cooler .....	B61112			<b>PARK AVENUE</b>			
Outlet Fitting To Trans. (Lower) .....			A63008	<b>2005</b>			
Outlet From Rad. (Lower) .....	B61111			<b>V-6 3.8 L ENG.</b>			
<b>1993</b>				<b>V-6 3.8 L ENG.</b>			
<b>V-6 3.8 L ENG.</b>				<b>Connector From Rad. ....</b>			
Aux. Cooler Supply From Rad. (Upper) .....	A61271			Inlet (Upper) .....	B61293		②A63018
Inlet Fitting To Trans. (Lower) .....			A63007	Outlet (Lower) .....	B61292		
Inlet From Rad. (Upper); W/Aux. Cooler .....	B61110			Wire Retainer (Connectors & Fittings) .....			④A63098
Inlet From Rad. (Upper); W/O Aux. Cooler .....	B61112			<b>2004</b>			
Outlet Fitting To Trans. (Upper) .....			A63008	<b>V-6 3.8 L ENG.</b>			
Outlet From Rad. (Lower) .....	B61244			<b>Connector From Rad. ....</b>			
Outlet To Trans. (Upper) .....	A61243			Inlet (Upper) .....	B61293		②A63018
<b>1992-1991</b>				<b>V-6 3.8 L ENG.</b>			
<b>V-6 3.8 L ENG.</b>				<b>Connector From Rad. ....</b>			
Aux. Cooler Supply From Rad. (Upper) .....	A61271			Inlet Fitting To Trans. (Upper) .....	B61292		A63064
Inlet Fitting To Trans. (Lower) .....			A63007	Outlet (Lower) .....	B61292		A63021
Inlet From Rad. (Upper); W/Aux. Cooler .....	B61245			Outlet Fitting To Trans. (Lower) .....			A63021
Inlet From Rad. (Upper); W/O Aux. Cooler .....	B61242			Wire Retainer (Connectors & Fittings) .....			④A63098
Inlet To Trans. (Lower) .....	A61274			<b>2003-2000</b>			
Outlet Fitting To Trans. (Upper) .....			A63008	<b>V-6 3.8 L ENG.</b>			
Outlet From Rad. (Lower) .....	B61244			<b>Connector From Rad. ....</b>			
Outlet To Trans. (Upper) .....	A61243			Inlet (Upper) .....	B61293		A63021
<b>1990-1988</b>				<b>V-6 3.8 L ENG.</b>			
<b>V-6 3.8 L ENG.</b>				<b>Connector From Rad. ....</b>			
Inlet Fitting To Trans. (Upper) .....			A63006	Inlet Fitting To Trans. (Upper) .....	B61292		A63064
Inlet Hose From Rad. (Upper); W/Aux. Cooler .....	B61036			Outlet (Lower) .....	B61292		A63064
Inlet Hose From Rad. (Upper); W/O Aux. Cooler .....		⊗A63000		Outlet Fitting To Trans. (Lower) .....			A63064
Inlet Tube From Rad. (Upper); W/O Aux. Cooler .....	B61032			Wire Retainer (Connectors & Fittings) .....			④A63098
Inlet Tube To Trans. (Upper) .....	A61034			<b>1999-1997</b>			
Outlet Hose To Trans. (Lower) .....	A61035			<b>V-6 3.8 L ENG.</b>			
Outlet Tube From Rad. (Lower); W/Aux. Cooler .....	B61037			<b>Inlet (Upper) .....</b>			
Outlet Tube From Rad. (Lower); W/O Aux. Cooler .....	B61033			<b>Inlet Fitting To Trans. (Upper) .....</b>			
<b>V-8 5.0 L ENG.</b>				<b>Outlet (Lower) .....</b>			
Inlet Fitting To Trans. (Upper) .....			A63006	<b>B61273</b>			
Inlet Hose From Rad. (Upper); W/Aux. Cooler .....	B61036			<b>B61272</b>			
Inlet Hose From Rad. (Upper); W/O Aux. Cooler .....		⊗A63004		<b>1996</b>			
Inlet Tube From Rad. (Upper); W/O Aux. Cooler .....	B61032			<b>1996</b>			
Inlet Tube To Trans. (Upper) .....	A61034			<b>V-6 3.8 L ENG.</b>			
Outlet Hose To Trans. (Lower) .....	A61035			<b>Aux. Cooler Supply From Rad. (Upper) .....</b>			
Outlet Tube From Rad. (Lower); W/Aux. Cooler .....	B61037			<b>(Upper) .....</b>			
Outlet Tube From Rad. (Lower); W/O Aux. Cooler .....	B61033			<b>Inlet Fitting To Trans. (Upper) .....</b>			
Tube Nut .....			●A63011	<b>Inlet From Rad. (Upper); W/O Aux. Cooler .....</b>			
				<b>Outlet (Lower) .....</b>			
				<b>B61099</b>			
				<b>1995-1994</b>			
				<b>V-6 3.8 L ENG.</b>			
				<b>Aux. Cooler Supply From Rad. (Upper) .....</b>			
				<b>(Upper) .....</b>			
				<b>A61271</b>			
				<b>Inlet Fitting To Trans. (Upper) .....</b>			
				<b>Inlet From Rad. (Upper); W/Aux. Cooler .....</b>			
				<b>W/O Aux. Cooler .....</b>			
				<b>B61110</b>			
				<b>Inlet From Rad. (Upper); W/O Aux. Cooler .....</b>			
				<b>W/O Aux. Cooler .....</b>			
				<b>B61112</b>			
				<b>Outlet Fitting To Trans. (Lower) .....</b>			
				<b>Outlet From Rad. (Lower) .....</b>			
				<b>B61111</b>			
				<b>1993-1991</b>			
				<b>V-6 3.8 L ENG.</b>			
				<b>Aux. Cooler Supply From Rad. (Upper) .....</b>			
				<b>(Upper) .....</b>			
				<b>A61271</b>			
				<b>Inlet Fitting To Trans. (Lower) .....</b>			
				<b>Outlet (Lower) .....</b>			
				<b>A63007</b>			

② Two Required.  
③ Three Required.

④ Four Required.  
⑤ Five Required.

⑥ Six Required.  
⑦ Seven Required.

⊗ Cut To Fit.  
● As Required.

See Pages 1 - 10 for Engine Oil Cooler Applications.

Product Section

Troubleshooting

EOC Applications

TOC Applications

Numerical Listing

Manufacturers' Part Numbers

End Fittings

Illustrations

## Transmission Oil Cooler Assemblies for Passenger Cars &amp; Light Trucks

Application	Assembly Number	Hoses & Tubes	Connectors & Fittings	Application	Assembly Number	Hoses & Tubes	Connectors & Fittings
<b>BUICK - Continued</b>				<b>BUICK - Continued</b>			
<b>PARK AVENUE - Continued</b>				<b>REGAL - Continued</b>			
<b>1993-1991 - Continued</b>				<b>1997</b>			
<b>V-6 3.8 L ENG. - Continued</b>				<b>V-6 3.8 L ENG.</b>			
Inlet From Rad. (Upper); W/Aux.				Inlet Fitting To Trans. (Upper).....			A63007
Cooler.....	B61245			Inlet To Trans. (Upper).....	A61031		
Inlet From Rad. (Upper); W/O Aux.				Outlet Fitting To Trans. (Lower);			A63008
Cooler.....	B61242			Eng. VIN K.....			
Inlet To Trans. (Lower).....	A61274		A63008	Outlet To Trans. (Lower).....	A61030		
Outlet Fitting To Trans. (Upper).....				<b>1996-1994</b>			
Outlet From Rad. (Lower).....	B61244			<b>V-6 3.1 L ENG.; V-6 3.8 L ENG.</b>			
Outlet To Trans. (Upper).....	A61243			Inlet Fitting To Trans. (Upper).....			A63007
<b>RAINIER</b>				Inlet To Trans. (Upper).....	A61031		A63008
<b>2004</b>				Outlet Fitting To Trans. (Lower).....			
<b>6-CYL. 4.2 L ENG.</b>				Outlet To Trans. (Lower).....	A61030		
Inlet Fitting To Trans. (Lower).....			A63021	<b>1993-1992</b>			
Outlet Fitting To Trans. (Upper).....			A63021	<b>V-6 3.1 L ENG.; V-6 3.8 L ENG.</b>			
Wire Retainer (Connectors & Fittings).....			●A63098	Inlet Fitting To Trans. (Upper).....			A63007
<b>V-8 5.3 L ENG.</b>				Inlet To Trans. (Upper).....	A61031		
Aux. Cooler Inlet (Pass. Side).....	B61264			Inlet Tube From Rad. (Upper).....		≠A63005	
Aux. Cooler Outlet (Driver Side).....	B61266			Outlet Fitting To Trans. (Lower).....			A63008
Connector From Rad.; W/Aux.				Outlet To Trans. (Lower).....	A61030		
Cooler.....			●A63019	Outlet Tube From Rad. (Lower).....		≠A63005	
Connector From Rad.; W/O Aux.				Tube Nut.....			●A63013
Cooler.....			●A63018	<b>1991</b>			
Inlet (Upper); W/O Aux. Cooler.....	B61267			<b>V-6 3.1 L ENG.</b>			
Inlet Fitting To Trans. (Upper).....			A63021	Inlet Fitting To Trans. (Upper);			
Outlet (Lower).....	B61262			W/3/8" Tubing.....			A63007
Outlet Fitting To Trans. (Lower).....			A63006	Inlet Fitting To Trans. (Upper);			
Wire Retainer (Connectors & Fittings).....			●A63098	W/5/16" Tubing; W/O Check Ball			A63006
<b>REATTA</b>				Inlet Hose To Trans. (Upper);			
<b>1991</b>				W/5/16" Tubing.....		≠A63000	
<b>V-6 3.8 L ENG.</b>				Inlet To Trans. (Upper); W/3/8"			
Inlet (Lower).....	B61143			Tubing.....	A61031		
Inlet Fitting To Trans. (Lower).....			A63007	Inlet Tube From Rad. (Upper);			
Outlet Fitting To Trans. (Upper).....			A63008	W/3/8" Tubing.....		≠A63005	
<b>1990-1988</b>				Inlet Tube From Rad. (Upper);			
<b>V-6 3.8 L ENG.</b>				W/5/16" Tubing.....		≠A63004	
Inlet Fitting To Trans. (Upper).....			A63006	Inlet Tube To Trans. (Upper);			
Inlet Hose (Upper).....		A63000		W/5/16" Tubing.....		≠A63004	
Inlet Tube (Upper).....		A63004		Outlet Fitting To Trans. (Lower);			A63008
Outlet Fitting To Trans. (Lower);				W/3/8" Tubing.....			
W/O Check Ball.....				Outlet Fitting To Trans. (Lower);			A63006
Outlet Hose (Lower).....		A63000		W/5/16" Tubing.....		≠A63000	
Outlet Tube (Lower).....		A63004		Outlet To Trans. (Lower); W/3/8"			
Tube Nut.....			●A63011	Tubing.....	A61030		
<b>REGAL</b>				Outlet Tube From Rad. (Lower);			
<b>2003-2000</b>				W/3/8" Tubing.....		≠A63005	
<b>V-6 3.8 L ENG.</b>				Outlet Tube From Rad. (Lower);			
Connector From Rad. ....			②A63065	W/5/16" Tubing.....		≠A63004	
Inlet Fitting To Trans. (Upper).....			A63021	Outlet Tube To Trans. (Lower);			
Outlet Fitting To Trans. (Lower).....			A63064	W/5/16" Tubing.....		≠A63004	
Wire Retainer (Connectors & Fittings).....			●A63098	Tube Nut; W/3/8" Tubing.....			●A63013
<b>1999-1998</b>				Tube Nut; W/5/16" Tubing.....			●A63011
<b>V-6 3.8 L ENG.</b>				<b>V-6 3.8 L ENG.</b>			
Connector From Rad. ....			②A63018	Inlet Fitting To Trans. (Upper).....			A63007
Inlet (Upper).....	B61239			Inlet To Trans. (Upper).....	A61031		
Inlet Fitting To Trans. (Upper).....			A63007	Inlet Tube From Rad. (Upper).....		≠A63005	
Outlet (Lower).....	B61238			Outlet Fitting To Trans. (Lower).....			A63008
Wire Retainer (Connectors).....			●A63098	Outlet To Trans. (Lower).....	A61030		
				Outlet Tube From Rad. (Lower).....		≠A63005	
				Tube Nut.....			●A63013
				<b>1990</b>			
				<b>V-6 3.1 L ENG.</b>			
				Inlet Fitting To Trans. (Upper).....			②A63006
				Outlet Hose To Trans. (Lower).....		≠A63000	

② Two Required.  
③ Three Required.

④ Four Required.  
⑤ Five Required.

⑥ Six Required.  
⑦ Seven Required.

≠ Cut To Fit.  
● As Required.

See Pages 1 - 10 for Engine Oil Cooler Applications.

## Transmission Oil Cooler Assemblies for Passenger Cars & Light Trucks

Application	Assembly Number	Hoses & Tubes	Connectors & Fittings	Application	Assembly Number	Hoses & Tubes	Connectors & Fittings
<b>BUICK - Continued</b>				<b>BUICK - Continued</b>			
<b>REGAL - Continued</b>				<b>RIVIERA - Continued</b>			
<b>1990 - Continued</b>				<b>1990</b>			
<b>V-6 3.1 L ENG. - Continued</b>				<b>V-6 3.8 L ENG.</b>			
Outlet Tube From Rad. (Lower) .....		∅-A63004	●A63011	Aux. Cooler Outlet Hose (Upper) ....		∅-A63000	
Tube Nut.....				Aux. Cooler Outlet Tube (Upper) ....		∅-A63004	②A63006
<b>V-6 3.8 L ENG.</b>				Inlet Fitting To Trans. (Lower).....			
Inlet Fitting To Trans. (Upper).....			A63007	Inlet Hose From Rad. To Trans. (Lower) .....		∅-A63000	
Inlet To Trans. (Upper).....	A61031			Inlet Tube From Rad. To Trans. (Lower) .....		∅-A63004	
Inlet Tube From Rad. (Upper).....		∅-A63005	A63008	Outlet Hose From Rad. (Upper) To Aux. Cooler (Lower).....			
Outlet Fitting To Trans. (Lower) .....				Outlet Hose To Trans. (Upper).....			
Outlet To Trans. (Lower) .....	A61030			Outlet Tube From Rad. (Upper) To Aux. Cooler (Lower).....			
Outlet Tube From Rad. (Lower) .....		∅-A63005	●A63013	Outlet Tube To Trans. (Upper).....			
Tube Nut.....				Tube Nut.....			
<b>1989</b>				<b>1989-1986</b>			
<b>V-6 2.8 L ENG.; V-6 3.1 L ENG.</b>				<b>V-6 3.8 L ENG.</b>			
Inlet Fitting To Trans. (Upper).....			②A63006	Inlet Fitting To Trans. (Lower).....			②A63006
Outlet Hose To Trans. (Lower).....		∅-A63000		Inlet Hose (Lower).....		∅-A63000	
Outlet Tube From Rad. (Lower) .....		∅-A63004	●A63011	Inlet Tube (Upper).....		∅-A63004	
Tube Nut.....				Outlet Hose (Upper).....		∅-A63000	
<b>1988</b>				Outlet Tube (Upper).....			
<b>V-6 2.8 L ENG.</b>				Tube Nut.....			
Inlet Fitting To Trans. (Upper).....			②A63006	<b>ROADMASTER</b>			
Outlet Hose To Trans. (Lower).....		∅-A63000		<b>1996-1994</b>			
Outlet Tube From Rad. (Lower) .....		∅-A63004	●A63011	<b>V-8 5.7 L ENG.</b>			
Tube Nut.....				Inlet Fitting To Trans. (Upper).....			
<b>1987-1986</b>				Outlet Fitting To Trans. (Lower) .....			
<b>V-6 3.8 L ENG.; V-8 5.0 L ENG.</b>				Rad. Supply Tube (Upper To Lower); W/Aux. Cooler .....			
Inlet Fitting To Trans. (Upper).....			A63006	Rad. Supply Tube Nut (Upper); W/Aux. Cooler.....			
Inlet Tube (Upper).....		∅-A63004					
Outlet Fitting To Trans. (Lower) .....			A63006				
Outlet Tube (Lower).....		∅-A63004	④A63013				
Tube Nut.....							
<b>RENDEZVOUS</b>				<b>1993-1992</b>			
<b>2003-2002</b>				<b>V-8 5.7 L ENG.</b>			
<b>V-6 3.4 L ENG.</b>				Inlet Fitting To Trans. (Upper).....			
Inlet Fitting To Trans. (Upper).....			A63021	Inlet Tube (Upper).....			
Outlet Fitting To Trans. (Lower) .....			A63064	Outlet Fitting To Trans. (Lower) .....			
Wire Retainer (Connectors & Fittings).....			●A63098	Outlet Tube (Lower).....			
<b>RIVIERA</b>				Tube Nut To Trans. (Upper).....			
<b>1999-1997</b>				Tube Nuts From Rad. ....			
<b>V-6 3.8 L ENG.</b>				<b>1991</b>			
Inlet Fitting To Trans. (Lower).....			A63007	<b>V-8 5.0 L ENG.</b>			
<b>1996-1995</b>				Inlet Fitting To Trans. (Upper).....			
<b>V-6 3.8 L ENG.</b>				Inlet Tube (Upper).....			
Inlet Fitting To Trans. (Lower).....			A63007	Outlet Fitting To Trans. (Lower) .....			
Outlet Fitting To Trans. (Upper) .....			A63008	Outlet Tube (Lower).....			
<b>1993-1991</b>				Tube Nut To Trans. (Upper).....			
<b>V-6 3.8 L ENG.</b>				Tube Nuts From Rad. ....			
Aux. Cooler Outlet Hose (Upper) ....		∅-A63001		<b>1991</b>			
Aux. Cooler Outlet Hose Fitting (Upper) .....			A63087	<b>V-8 5.0 L ENG.</b>			
Inlet Fitting To Trans. (Lower).....			A63007	Inlet Fitting To Trans. (Upper).....			
Inlet From Rad. (Upper).....	B61137			Inlet Tube (Upper).....			
Outlet Fitting To Trans. (Upper) .....			A63008	Outlet Fitting To Trans. (Lower) .....			
Outlet From Rad. (Lower).....	B61143			Outlet Tube (Lower).....			
Outlet To Trans. (Upper) .....	A61140			Tube Nut To Trans. (Upper).....			
				Tube Nuts From Rad. ....			
				<b>SKYHAWK</b>			
				<b>1989-1987</b>			
				<b>4-CYL. 2.0 L ENG.</b>			
				Inlet (Upper) .....	A61230		
				Inlet Fitting To Trans. (Upper).....			A63006
				Outlet (Lower).....	A61150		
				Outlet Fitting To Trans. (Lower) .....			A63006
				<b>1986-1985</b>			
				<b>4-CYL. 1.8 L ENG.; 4-CYL. 2.0 L ENG.</b>			
				Inlet (Upper) .....	A61230		
				Inlet Fitting To Trans. (Upper).....			A63006
				Outlet (Lower).....	A61150		
				Outlet Fitting To Trans. (Lower) .....			

② Two Required.  
③ Three Required.

④ Four Required.  
⑤ Five Required.

⑥ Six Required.  
⑦ Seven Required.

∅ Cut To Fit.  
● As Required.

See Pages 1 - 10 for Engine Oil Cooler Applications.

## Transmission Oil Cooler Assemblies for Passenger Cars &amp; Light Trucks

Application	Assembly Number	Hoses & Tubes	Connectors & Fittings	Application	Assembly Number	Hoses & Tubes	Connectors & Fittings
<b>BUICK - Continued</b>				<b>BUICK - Continued</b>			
<b>SKYHAWK - Continued</b>				<b>SKYLARK - Continued</b>			
<b>1986-1985 - Continued</b>				<b>1988 - Continued</b>			
4-CYL. 1.8 L ENG.; 4-CYL. 2.0 L ENG. - Continued				4-CYL. 2.3 L ENG.; V-6 3.0 L ENG. - Continued			
Outlet Fitting To Trans. (Lower) .....			A63006	Outlet Fitting To Trans. (Lower) .....			A63006
<b>SKYLARK</b>				4-CYL. 2.5 L ENG.			
<b>1998-1996</b>				Inlet (Upper) .....			
4-CYL. 2.4 L ENG.; V-6 3.1 L ENG.				A61223			
Inlet (Upper) .....	B61119		A63007	Inlet Fitting To Trans. (Upper) .....			A63006
Inlet Fitting To Trans. (Upper) .....			A63008	Outlet (Lower) .....	A61248		
Outlet (Lower) .....	A61134			Outlet Fitting To Trans. (Lower) .....			A63006
Outlet Fitting To Trans. (Lower) .....				<b>1987-1986</b>			
<b>1995-1994</b>				4-CYL. 2.5 L ENG.; V-6 3.0 L ENG.			
4-CYL. 2.3 L ENG.				Inlet (Upper) .....			
Inlet (Upper); W/3-Speed Trans. ....	B61232		A63006	Inlet Fitting To Trans. (Upper) .....	A61231		A63006
Inlet (Upper); W/4-Speed Trans. ....	B61119		A63007	Outlet (Lower) .....	A61249		A63006
Inlet Fitting To Trans. (Upper);				Outlet Fitting To Trans. (Lower) .....			A63006
W/3-Speed Trans. ....				<b>1985</b>			
Inlet Fitting To Trans. (Upper);				4-CYL. 2.5 L ENG.; V-6 2.8 L ENG.			
W/4-Speed Trans. ....				Inlet (Upper) .....	A61231		A63006
Outlet (Lower); W/3-Speed Trans. ....	B61233		A63006	Inlet Fitting To Trans. (Upper) .....			A63006
Outlet (Lower); W/4-Speed Trans. ....	A61134			Outlet (Lower) .....	A61249		A63006
Outlet Fitting To Trans. (Lower);				Outlet Fitting To Trans. (Lower) .....			
W/3-Speed Trans. ....				<b>SOMERSET</b>			
Outlet Fitting To Trans. (Lower);			A63008	<b>1987-1986</b>			
W/4-Speed Trans. ....				4-CYL. 2.5 L ENG.			
<b>V-6 3.1 L ENG.</b>				Inlet (Upper) .....			
Inlet (Upper) .....	B61119		A63007	Inlet Fitting To Trans. (Upper) .....	A61231		A63006
Inlet Fitting To Trans. (Upper) .....			A63008	Outlet (Lower) .....	A61248		A63006
Outlet (Lower) .....	A61134			Outlet Fitting To Trans. (Lower) .....			A63006
Outlet Fitting To Trans. (Lower) .....				<b>V-6 3.0 L ENG.</b>			
<b>1993-1992</b>				Inlet (Upper) .....			
4-CYL. 2.3 L ENG.; V-6 3.3 L ENG.				A61231			
Inlet (Upper) .....	A61228		A63006	Inlet Fitting To Trans. (Upper) .....			A63006
Inlet Fitting To Trans. (Upper) .....				Outlet (Lower) .....	A61249		A63006
Outlet (Lower) .....	A61227		A63006	Outlet Fitting To Trans. (Lower) .....			
Outlet Fitting To Trans. (Lower) .....				<b>SOMERSET REGAL</b>			
<b>1991-1990</b>				<b>1985</b>			
4-CYL. 2.3 L ENG.; V-6 3.3 L ENG.				4-CYL. 2.5 L ENG.			
Inlet (Upper) .....	A61225		A63006	Inlet (Upper) .....	A61231		A63006
Inlet Fitting To Trans. (Upper) .....			A63006	Inlet Fitting To Trans. (Upper) .....			A63006
Outlet (Lower) .....	A61226			Outlet (Lower) .....	A61248		A63006
Outlet Fitting To Trans. (Lower) .....				Outlet Fitting To Trans. (Lower) .....			
<b>4-CYL. 2.5 L ENG.</b>				<b>V-6 3.0 L ENG.</b>			
Inlet (Upper) .....	A61224		A63006	Inlet (Upper) .....	A61231		A63006
Inlet Fitting To Trans. (Upper) .....			A63006	Inlet Fitting To Trans. (Upper) .....			A63006
Outlet (Lower) .....	A61248		A63006	Outlet (Lower) .....	A61249		A63006
Outlet Fitting To Trans. (Lower) .....				Outlet Fitting To Trans. (Lower) .....			
<b>1989</b>				<b>CADILLAC</b>			
4-CYL. 2.3 L ENG.; V-6 3.3 L ENG.				<b>ALLANTE</b>			
Inlet (Upper) .....	A61223		A63006	<b>1993</b>			
Inlet Fitting To Trans. (Upper) .....			A63006	V-8 4.6 L ENG.			
Outlet (Lower) .....	A61222			Inlet Fitting "O" Ring .....			
Outlet Fitting To Trans. (Lower) .....				A63089			
<b>4-CYL. 2.5 L ENG.</b>				Inlet From Rad. (Upper);			
Inlet (Upper) .....	A61223		A63006	W/Mid-Year ID Tag .....			
Inlet Fitting To Trans. (Upper) .....			A63006	B61105			
Outlet (Lower) .....	A61248		A63006	Outlet Fitting "O" Ring .....			
Outlet Fitting To Trans. (Lower) .....				A63089			
<b>1988</b>				Outlet From Rad. (Lower) .....			
4-CYL. 2.3 L ENG.; V-6 3.0 L ENG.				A61300			
Inlet (Upper) .....	A61223		A63006	<b>1992-1990</b>			
Inlet Fitting To Trans. (Upper) .....				V-8 4.5 L ENG.			
Outlet (Lower) .....	A61222			Inlet Fitting To Trans. (Upper) .....			
				A63007			
				Outlet Fitting To Trans. (Lower) .....			
				A63008			

② Two Required.  
③ Three Required.

④ Four Required.  
⑤ Five Required.

⑥ Six Required.  
⑦ Seven Required.

≠ Cut To Fit.  
● As Required.

See Pages 1 - 10 for Engine Oil Cooler Applications.

# Transmission Oil Cooler Assemblies for Passenger Cars & Light Trucks

Application	Assembly Number	Hoses & Tubes	Connectors & Fittings	Application	Assembly Number	Hoses & Tubes	Connectors & Fittings
<b>CADILLAC - Continued</b>				<b>CADILLAC - Continued</b>			
<b>ALLANTE - Continued</b>				<b>DEVILLE - Continued</b>			
<b>1989</b>				<b>2000</b>			
<b>V-8 4.5 L ENG.</b>				<b>V-8 4.6 L ENG.</b>			
Inlet Fitting To Trans. (Upper).....			A63006	Connector From Rad. (Upper).....			A63018
Outlet Fitting To Trans. (Lower);				Inlet Fitting "O" Ring (Upper).....			A63090
W/O Check Ball .....			A63006	Outlet Fitting "O" Ring (Lower).....			A63089
				Wire Retainer (Connectors).....			A63098
<b>1988-1987</b>				<b>1999-1996</b>			
<b>V-8 4.1 L ENG.</b>				<b>V-8 4.6 L ENG.</b>			
Inlet Fitting To Trans. (Upper).....			A63006	Inlet Fitting "O" Ring (Upper).....			A63090
Outlet Fitting To Trans. (Lower);				Inlet From Rad. (Upper).....	B61106		A63089
W/O Check Ball .....			A63006	Outlet Fitting "O" Ring (Lower).....			
				Outlet From Rad. (Lower).....	A61300		
<b>BROUGHAM</b>				<b>1995-1994</b>			
<b>1992</b>				<b>V-8 4.6 L ENG.</b>			
<b>V-8 5.0 L ENG.</b>				<b>V-8 4.9 L ENG.</b>			
Inlet Fitting To Trans. (Upper).....			②A63006	Aux. Cooler Outlet Hose (Upper) ...		≈A63001	
Outlet Fitting To Trans. (Lower).....			A63006	Aux. Cooler Outlet Hose Fitting			
				(Upper) .....			A63087
<b>V-8 5.7 L ENG.</b>				Inlet Fitting To Trans. (Lower).....			
Inlet Fitting To Trans. (Upper).....			②A63006	Inlet From Rad. (Upper).....	B61137		A63008
				Outlet Fitting To Trans. (Upper).....			
<b>1991-1990</b>				Outlet From Rad. (Lower).....			
<b>V-8 5.0 L ENG.; V-8 5.7 L ENG.</b>				Outlet To Trans. (Upper).....			
Inlet Fitting To Trans. (Upper).....			②A63006	Outlet From Rad. (Lower).....	B61143		
Outlet Fitting To Trans. (Lower).....			A63006	Outlet To Trans. (Upper).....	A61140		
<b>1989-1987</b>				<b>1993-1991</b>			
<b>V-8 5.0 L ENG.</b>				<b>V-8 4.9 L ENG.</b>			
Inlet Fitting To Trans. (Upper).....			②A63006	Aux. Cooler Supply From Rad.			
Outlet Fitting To Trans. (Lower).....			A63006	(Upper) .....	A61271		A63007
				Inlet Fitting To Trans. (Lower).....			
<b>CIMARRON</b>				Inlet From Rad. (Upper); W/Aux.			
<b>1988-1987</b>				Cooler.....			
<b>V-6 2.8 L ENG.</b>				Inlet From Rad. (Upper); W/O Aux.			
Inlet (Upper).....	A61231			Cooler.....	B61242		
Inlet Fitting To Trans. (Upper).....			A63006	Inlet To Trans. (Lower).....	A61274		
Outlet (Lower).....	A61249			Outlet Fitting To Trans. (Upper).....			A63008
Outlet Fitting To Trans. (Lower).....			A63006	Outlet From Rad. (Lower).....	B61244		
				Outlet To Trans. (Upper).....	A61243		
<b>1986-1985</b>				<b>1990-1988</b>			
<b>4-CYL. 2.0 L ENG.</b>				<b>V-8 4.5 L ENG.</b>			
Inlet (Upper).....			≈A63004	Inlet Fitting To Trans. (Upper).....			A63006
Inlet Fitting To Trans. (Upper).....				Inlet Tube From Rad. (Upper).....		≈A63004	
Outlet (Lower).....			≈A63004	Outlet Tube From Rad. (Lower).....		≈A63004	
Outlet Fitting To Trans. (Lower).....				Tube Nut.....			②A63011
Tube Nut.....			A63006				
			●A63011	<b>ELDORADO</b>			
<b>V-6 2.8 L ENG.</b>				<b>2002</b>			
Inlet (Upper).....	A61231			<b>V-8 4.6 L ENG.</b>			
Inlet Fitting To Trans. (Upper).....			A63006	Connector From Rad. (Upper).....			
Outlet (Lower).....	A61249			Inlet Fitting "O" Ring (Upper).....			
Outlet Fitting To Trans. (Lower).....			A63006	Inlet Fitting To Trans. (Upper);			
				W/Quick Connect Fitting.....			
				Outlet Fitting "O" Ring (Lower).....			
				Outlet Fitting To Trans. (Lower);			
				W/Quick Connect Fitting.....			
				Outlet From Rad. (Lower); 1st De-			
				sign; W/Threaded Fitting.....			
				Outlet Seal From Rad. (Lower).....			
				Wire Retainer (Connectors & Fit-			
				tings).....			

② Two Required.  
③ Three Required.

④ Four Required.  
⑤ Five Required.

⑥ Six Required.  
⑦ Seven Required.

≈ Cut To Fit.  
● As Required.

See Pages 1 - 10 for Engine Oil Cooler Applications.

Product Section

Troubleshooting

EOC Applications

TOC Applications

Numerical Listing

Manufacturers' Part Numbers

End Fittings

Illustrations

## Transmission Oil Cooler Assemblies for Passenger Cars &amp; Light Trucks

Application	Assembly Number	Hoses & Tubes	Connectors & Fittings	Application	Assembly Number	Hoses & Tubes	Connectors & Fittings
<b>CADILLAC - Continued</b>				<b>CADILLAC - Continued</b>			
<b>ELDORADO - Continued</b>				<b>ELDORADO - Continued</b>			
<b>2001</b>				<b>1990 - Continued</b>			
<b>V-8 4.6 L ENG.</b>				<b>V-8 4.5 L ENG. - Continued</b>			
Connector From Rad. (Upper).....			A63065	Outlet Tube From Rad. (Upper) To			
Inlet Fitting "O" Ring (Upper).....			A63090	Aux. Cooler (Lower).....		¾ A63000	
Inlet Fitting To Trans. (Upper);				Outlet Tube To Trans. (Upper).....		¾ A63000	
W/Quick Connect Fitting.....			A63063	Tube Nut.....			● A63011
Inlet From Rad. (Upper); 1st De-				<b>1989-1988</b>			
sign; W/Threaded Fitting.....	B61106			<b>V-8 4.5 L ENG.</b>			
Outlet Fitting "O" Ring (Lower).....			A63089	Inlet Fitting To Trans. (Upper).....			
Outlet Fitting To Trans. (Lower);							A63006
W/Quick Connect Fitting.....			A63025	<b>ESCALADE</b>			
Outlet From Rad. (Lower).....	A61300			<b>2004-2002</b>			
Outlet Seal From Rad. (Lower).....			A63108	<b>V-8 5.3 L ENG.; V-8 6.0 L ENG.</b>			
Wire Retainer (Connectors).....			A63098	Aux. Cooler Inlet (Pass. Side).....	B61264		
<b>2000-1996</b>				Aux. Cooler Outlet (Driver Side).....	B61266		
<b>V-8 4.6 L ENG.</b>				Connector From Rad.; W/Aux.			
Inlet Fitting "O" Ring (Upper).....			A63090	Cooler.....			● A63019
Inlet From Rad. (Upper).....	B61106		A63089	Connector From Rad.; W/O Aux.			● A63018
Outlet Fitting "O" Ring (Lower).....				Cooler.....			A63021
Outlet From Rad. (Lower).....	A61300			Inlet (Upper); W/O Aux. Cooler.....	B61267		
<b>1995-1994</b>				Inlet Fitting To Trans. (Upper).....			A63021
<b>V-8 4.6 L ENG.</b>				Outlet (Lower).....	B61262		
Inlet Fitting "O" Ring (Upper).....			A63090	Outlet Fitting To Trans. (Lower).....			A63006
Inlet Fitting To Trans. (Upper).....			② A63006	Wire Retainer (Connectors & Fit-			● A63098
Inlet From Rad. (Upper).....	B61105			tings).....			
Outlet Fitting "O" Ring (Lower).....			A63089	<b>2000-1999</b>			
Outlet From Rad. (Lower).....	A61300			<b>V-8 5.7 L ENG.</b>			
<b>1993</b>				Aux. Cooler Inlet (Driver Side).....	B61058		
<b>V-8 4.6 L ENG.</b>				Aux. Cooler Outlet (Pass. Side).....	B61056		
Inlet Fitting "O" Ring (Upper).....			A63090	Connector From Aux. Cooler.....			② A63019
Inlet Fitting To Trans. (Upper).....			② A63006	Inlet Fitting To Trans. (Upper).....			A63007
Inlet From Rad. (Upper).....	B61105			Inlet Tube (Upper); W/Aux. Cooler;			
Outlet Fitting "O" Ring (Lower).....			A63089	Service Item; Remove Current			
Outlet From Rad. (Lower).....	B61143			Line & Trans. Fittings. Replace			
<b>V-8 4.9 L ENG.</b>				Using Bulk Tubing & Service			
Aux. Cooler Outlet Hose (Upper) ...			¾ A63001	Item Listed.....			¾ A63005
Aux. Cooler Outlet Hose Fitting				Inlet Tube (Upper); W/O Aux. Cool-			
(Upper).....			A63087	er.....	B61057		
Inlet Fitting To Trans. (Lower).....			A63007	Outlet (Lower); W/O Aux. Cooler ...	B61055		
Inlet From Rad. (Upper).....	B61137			Outlet Fitting To Trans. (Lower).....			A63007
Outlet Fitting To Trans. (Upper).....			A63008	Quick Connect Tube Fitting (Low-			
Outlet From Rad. (Lower).....	B61143			er).....			A63021
Outlet To Trans. (Upper).....	A61140			Quick Connect Tube Fitting (Up-			
<b>1992-1991</b>				per).....			A63021
<b>V-8 4.9 L ENG.</b>				Tube Nut; Service Item.....			② A63013
Aux. Cooler Outlet Hose (Upper) ...			¾ A63001	Wire Retainer (Connectors & Fit-			● A63098
Aux. Cooler Outlet Hose Fitting				tings); W/3/8" Retainer.....			● A63099
(Upper).....			A63087	Wire Retainer (Connectors & Fit-			
Inlet Fitting To Trans. (Lower).....			A63007	tings); W/5/8" Retainer.....			
Inlet From Rad. (Upper).....	B61137			<b>FLEETWOOD</b>			
Outlet Fitting To Trans. (Upper).....			A63008	<b>1996-1994</b>			
Outlet From Rad. (Lower).....	B61143			<b>V-8 5.7 L ENG.</b>			
Outlet To Trans. (Upper).....	A61140			Inlet Fitting To Trans. (Lower).....			
<b>1990</b>				Outlet Fitting To Trans. (Upper).....			
<b>V-8 4.5 L ENG.</b>				A63007			
Aux. Cooler Outlet Hose (Upper) ...			¾ A63004	A63007			
Aux. Cooler Outlet Tube (Upper) ...			¾ A63000	<b>1993</b>			
Inlet Fitting To Trans. (Lower).....				<b>V-8 5.7 L ENG.</b>			
Inlet Hose From Rad. To Trans.			A63006	Inlet Fitting To Trans. (Upper).....			
(Lower).....				Inlet From Rad. (Upper).....			
Inlet Tube From Rad. To Trans.				Outlet Fitting To Trans. (Lower).....			
(Lower).....			¾ A63000	Outlet From Rad. (Lower).....			
Outlet Hose From Rad. (Upper) To				Tube Nut From Rad. (Lower).....			
Aux. Cooler (Lower).....			¾ A63004	Tube Nut From Rad. (Upper).....			
Outlet Hose To Trans. (Upper).....			¾ A63004	A63006			

② Two Required.  
③ Three Required.

④ Four Required.  
⑤ Five Required.

⑥ Six Required.  
⑦ Seven Required.

¾ Cut To Fit.  
● As Required.

See Pages 1 - 10 for Engine Oil Cooler Applications.



## Transmission Oil Cooler Assemblies for Passenger Cars & Light Trucks

Application	Assembly Number	Hoses & Tubes	Connectors & Fittings	Application	Assembly Number	Hoses & Tubes	Connectors & Fittings
<b>CADILLAC - Continued</b>				<b>CADILLAC - Continued</b>			
<b>FLEETWOOD - Continued</b>				<b>SEVILLE - Continued</b>			
<b>1992-1991</b>				<b>1993 - Continued</b>			
<b>V-8 4.9 L ENG.</b>				<b>V-8 4.6 L ENG. - Continued</b>			
Aux. Cooler Supply From Rad. (Upper) .....	A61271			Outlet From Rad. (Lower).....	A61300		
Inlet Fitting To Trans. (Lower).....			A63007	<b>V-8 4.9 L ENG.</b>			
Inlet From Rad. (Upper); W/Aux. Cooler.....	B61245			Aux. Cooler Outlet Hose (Upper) ...		≠A63001	
Inlet From Rad. (Upper); W/O Aux. Cooler.....	B61242			Aux. Cooler Outlet Hose Fitting (Upper) .....			A63087
Inlet To Trans. (Lower) .....	A61274			Inlet Fitting To Trans. (Lower).....			A63007
Outlet Fitting To Trans. (Upper).....			A63008	Inlet From Rad. (Upper).....	B61137		
Outlet From Rad. (Lower).....	B61244			Outlet Fitting To Trans. (Upper).....			A63008
Outlet To Trans. (Upper) .....	A61243			Outlet From Rad. (Lower).....	B61143		
				Outlet To Trans. (Upper) .....	A61140		
<b>1990</b>				<b>1992-1991</b>			
<b>V-8 4.5 L ENG.</b>				<b>V-8 4.9 L ENG.</b>			
Inlet Fitting To Trans. (Upper).....			A63006	Aux. Cooler Outlet Hose (Upper) ...		≠A63001	
Inlet Tube From Rad. (Upper).....	≠A63004			Aux. Cooler Outlet Hose Fitting (Upper) .....			A63087
Outlet Tube From Rad. (Lower).....	≠A63004		②A63011	Inlet Fitting To Trans. (Lower).....			A63007
Tube Nut.....				Inlet From Rad. (Upper).....	B61137		
				Outlet Fitting To Trans. (Upper).....			A63008
<b>1989-1988</b>				<b>1990</b>			
<b>V-8 4.5 L ENG.</b>				<b>V-8 4.5 L ENG.</b>			
Inlet Fitting To Trans. (Lower).....			A63006	Aux. Cooler Outlet Hose (Upper) ...		≠A63000	
Inlet Tube From Rad. (Upper).....	≠A63004			Aux. Cooler Outlet Tube (Upper) ...		≠A63004	
Outlet Tube From Rad. (Lower).....	≠A63004		②A63011	Inlet Fitting To Trans. (Lower).....			A63006
Tube Nut.....				Inlet Hose From Rad. To Trans. (Lower) .....		≠A63000	
				Inlet Tube From Rad. To Trans. (Lower) .....		≠A63004	
<b>SEVILLE</b>				<b>1990</b>			
<b>2003-2001</b>				<b>V-8 4.5 L ENG.</b>			
<b>V-8 4.6 L ENG.</b>				Aux. Cooler Outlet Hose (Upper) ...			
Connector From Rad. (Upper).....			A63065	Aux. Cooler Outlet Tube (Upper) ...		≠A63004	
Inlet Fitting "O" Ring (Upper).....			A63090	Inlet Fitting To Trans. (Lower).....			A63006
Inlet Fitting To Trans. (Upper); W/Quick Connect Fitting.....			A63063	Inlet Hose From Rad. To Trans. (Lower) .....		≠A63000	
Outlet Fitting "O" Ring (Lower).....			A63089	Inlet Tube From Rad. To Trans. (Lower) .....		≠A63004	
Outlet Fitting To Trans. (Lower); W/Quick Connect Fitting.....			A63025	Outlet Tube From Rad. (Upper) To Aux. Cooler (Lower).....		≠A63004	
Outlet Seal From Rad. (Lower).....			A63108	Outlet Tube To Trans. (Upper).....		≠A63004	
Wire Retainer (Connectors).....			A63098	Tube Nut.....			●A63011
<b>2000</b>				<b>1989-1988</b>			
<b>V-8 4.6 L ENG.</b>				<b>V-8 4.5 L ENG.</b>			
Connector From Rad. (Upper).....			A63018	Inlet Fitting To Trans. (Upper).....			A63006
Inlet Fitting "O" Ring (Upper).....			A63090				
Outlet Fitting "O" Ring (Lower).....			A63089	<b>SIXTY SPECIAL</b>			
Wire Retainer (Connectors).....			A63098	<b>1993</b>			
<b>1999-1996</b>				<b>V-8 4.9 L ENG.</b>			
<b>V-8 4.6 L ENG.</b>				Aux. Cooler Supply From Rad. (Upper) .....			
Inlet Fitting "O" Ring (Upper).....			A63090	(Upper) .....	A61271		
Inlet From Rad. (Upper).....	B61106			Inlet Fitting To Trans. (Lower).....			A63007
Outlet Fitting "O" Ring (Lower).....			A63089	Inlet From Rad. (Upper); W/Aux. Cooler.....	B61245		
Outlet From Rad. (Lower).....	A61300			Inlet From Rad. (Upper); W/O Aux. Cooler.....	B61242		
<b>1995-1994</b>				<b>1993</b>			
<b>V-8 4.6 L ENG.</b>				<b>V-8 4.6 L ENG.</b>			
Inlet Fitting "O" Ring (Upper).....			A63090	Inlet Fitting "O" Ring (Upper).....			A63008
Inlet Fitting To Trans. (Upper).....			②A63006	Inlet From Rad. (Upper).....	B61105		
Inlet From Rad. (Upper).....	B61105			Outlet Fitting "O" Ring (Lower).....			A63089
Outlet Fitting "O" Ring (Lower).....			A63089	Outlet From Rad. (Lower).....	A61300		
Outlet From Rad. (Lower).....	A61300			<b>CHEVROLET</b>			
<b>1993</b>				<b>ASTRO</b>			
<b>V-8 4.6 L ENG.</b>				<b>2005-1996</b>			
Inlet Fitting To Trans. (Upper).....			A63007	<b>V-6 4.3 L ENG.</b>			
Inlet From Rad. (Upper).....	B61105			Connector From Rad. ....			②A63018
Outlet Fitting To Trans. (Lower).....			A63008	Inlet (Upper) .....	B61251		

② Two Required.  
③ Three Required.

④ Four Required.  
⑤ Five Required.

⑥ Six Required.  
⑦ Seven Required.

≠ Cut To Fit.  
● As Required.

See Pages 1 - 10 for Engine Oil Cooler Applications.

Product Section

Troubleshooting

EOC Applications

TOC Applications

Numerical Listing

Manufacturers' Part Numbers

End Fittings

Illustrations

## Transmission Oil Cooler Assemblies for Passenger Cars &amp; Light Trucks

Application	Assembly Number	Hoses & Tubes	Connectors & Fittings	Application	Assembly Number	Hoses & Tubes	Connectors & Fittings
<b>CHEVROLET - Continued</b>				<b>CHEVROLET - Continued</b>			
<b>ASTRO - Continued</b>				<b>BERETTA</b>			
<b>2005-1996 - Continued</b>				<b>1996-1995</b>			
<b>V-6 4.3 L ENG. - Continued</b>				<b>4-CYL. 2.2 L ENG.</b>			
Inlet Fitting To Trans. (Upper).....	B61250		A63021	Inlet (Upper); W/3-Speed Trans. ....	B61232		
Outlet (Lower).....			A63021	Inlet Fitting To Trans. (Upper).....			②A63006
Outlet Fitting To Trans. (Lower).....			④A63098	Outlet (Lower); W/3-Speed Trans....	B61233		
Wire Retainer (Connectors & Fittings).....				Outlet Fitting To Trans. (Lower).....			
<b>1995</b>				<b>V-6 3.1 L ENG.</b>			
<b>V-6 4.3 L ENG.</b>				Inlet (Upper).....			
Inlet Fitting To Trans. (Upper).....			A63006	Inlet Fitting To Trans. (Upper).....	B61119		A63007
Outlet Fitting To Trans. (Lower).....			A63006	Outlet (Lower).....	A61134		A63008
<b>1994-1991</b>				Outlet Fitting To Trans. (Lower).....			
<b>V-6 4.3 L ENG.</b>				Inlet (Upper).....			
Inlet Fitting To Trans. (Upper).....			A63006	Inlet Fitting To Trans. (Upper).....			A63007
Inlet Tube (Upper).....		≠A63004	A63006	Outlet (Lower).....	A61134		A63008
Outlet Fitting To Trans. (Lower).....			A63006	Outlet Fitting To Trans. (Lower).....			
Outlet Tube (Lower).....		≠A63004	④A63011	<b>1994</b>			
Tube Nut.....				<b>4-CYL. 2.2 L ENG.</b>			
<b>1990</b>				Inlet (Upper); W/3-Speed Trans. ....			
<b>4-CYL. 2.5 L ENG.</b>				Inlet (Upper); W/4-Speed Trans. ....			
Connector From Rad. ....			②A63006	Inlet Fitting To Trans. (Upper);			A63006
Inlet Fitting To Trans. (Upper).....			A63006	W/4-Speed Trans. ....			A63007
Inlet Tube (Upper).....		≠A63004	A63006	Outlet (Lower); W/3-Speed Trans....	B61233		
Outlet Fitting To Trans. (Lower).....			A63006	Outlet (Lower); W/4-Speed Trans....	A61134		
Outlet Tube (Lower).....		≠A63004	④A63011	Outlet Fitting To Trans. (Lower);			A63006
Tube Nut.....				W/3-Speed Trans. ....			A63008
<b>V-6 4.3 L ENG.</b>				Outlet Fitting To Trans. (Lower);			
Connector From Rad.; W/RWD.....			②A63006	W/4-Speed Trans. ....			A63008
Inlet Fitting To Trans. (Upper).....			A63006	<b>V-6 3.1 L ENG.</b>			
Inlet Tube (Upper).....		≠A63004	A63006	Inlet (Upper).....			
Outlet Fitting To Trans. (Lower).....			A63006	Inlet Fitting To Trans. (Upper).....			
Outlet Tube (Lower).....		≠A63004	④A63011	Outlet (Lower).....			
Tube Nut.....				Outlet Fitting To Trans. (Lower).....			
<b>1989-1985</b>				Outlet (Lower).....			
<b>4-CYL. 2.5 L ENG.; V-6 4.3 L ENG.</b>				W/3-Speed Trans. ....			
Connector From Rad. ....			②A63006	W/4-Speed Trans. ....			
Inlet Fitting To Trans. (Upper).....			A63006	<b>V-6 3.1 L ENG.</b>			
Inlet Tube (Upper).....		≠A63004	A63006	Inlet (Upper).....			
Outlet Fitting To Trans. (Lower).....			A63006	Inlet Fitting To Trans. (Upper).....			
Outlet Tube (Lower).....		≠A63004	④A63011	Outlet (Lower).....			
Tube Nut.....				Outlet Fitting To Trans. (Lower).....			
<b>2003-2002</b>				Outlet (Lower).....			
<b>V-8 5.3 L ENG.</b>				W/3-Speed Trans. ....			
Aux. Cooler Inlet (Pass. Side).....	B61264			W/4-Speed Trans. ....			
Aux. Cooler Outlet (Driver Side).....	B61266			<b>1993-1992</b>			
Connector From Rad.; W/Aux.			●A63019	<b>4-CYL. 2.2 L ENG.; V-6 3.1 L ENG.</b>			
Cooler.....			●A63018	Inlet (Upper).....			
Connector From Rad.; W/O Aux.			A63021	Inlet Fitting To Trans. (Upper).....			
Cooler.....			A63006	Outlet (Lower).....			
Inlet (Upper); W/O Aux. Cooler.....	B61267		A63006	Outlet Fitting To Trans. (Lower).....			
Inlet Fitting To Trans. (Upper).....			●A63098	<b>1991-1990</b>			
Outlet (Lower).....	B61262			<b>4-CYL. 2.2 L ENG.; V-6 3.1 L ENG.</b>			
Outlet Fitting To Trans. (Lower).....				Inlet (Upper); W/3-Speed Trans. ....			
Wire Retainer (Connectors & Fittings).....				Inlet Fitting To Trans. (Upper).....			
<b>V-8 8.1 L ENG.</b>				Outlet (Lower); W/3-Speed Trans....			
Connector From Aux. Cooler.....			②A63019	Outlet Fitting To Trans. (Lower).....			
Inlet Fitting To Trans. (Upper).....			A63021	<b>1989-1987</b>			
Inlet From Rad. (Lower).....	B61270		A63021	<b>4-CYL. 2.0 L ENG.; V-6 2.8 L ENG.</b>			
Outlet Fitting To Trans. (Lower).....			●A63098	Inlet (Upper); W/3-Speed Trans. ....			
Wire Retainer (Connectors & Fittings).....				Inlet Fitting To Trans. (Upper).....			
				Outlet (Lower); W/3-Speed Trans....			
				Outlet Fitting To Trans. (Lower).....			
				<b>BLAZER</b>			
				<b>2004-1996</b>			
				<b>V-6 4.3 L ENG.</b>			
				Connector From Rad. ....			
				Inlet (Lower).....			
				Inlet Fitting To Trans. (Lower).....			
				Outlet (Upper).....			
				Outlet Fitting To Trans. (Upper).....			

② Two Required.  
③ Three Required.

④ Four Required.  
⑤ Five Required.

⑥ Six Required.  
⑦ Seven Required.

≠ Cut To Fit.  
● As Required.

See Pages 1 - 10 for Engine Oil Cooler Applications.

# Transmission Oil Cooler Assemblies for Passenger Cars & Light Trucks

Application	Assembly Number	Hoses & Tubes	Connectors & Fittings	Application	Assembly Number	Hoses & Tubes	Connectors & Fittings
<b>CHEVROLET - Continued</b>				<b>CHEVROLET - Continued</b>			
<b>BLAZER - Continued</b>				<b>BLAZER - Continued</b>			
<b>2004-1996 - Continued</b>				<b>1993 - Continued</b>			
<b>V-6 4.3 L ENG. - Continued</b>				<b>V-8 5.7 L ENG. - Continued</b>			
Wire Retainer (Connectors & Fittings).....			●A63098	Inlet Fitting To Trans. (Upper).....			A63006
<b>1995</b>				Inlet Tube (Upper).....	∞A63004		A63006
<b>V-6 4.3 L ENG.</b>				Outlet Fitting To Trans. (Lower).....			A63006
Connector From Rad.....			②A63006	Outlet Tube (Lower); W/O Aux. Cooler.....	∞A63004		
Inlet Fitting To Trans. (Lower).....			A63006	Tube Nut; W/Aux. Cooler.....			②A63011
Inlet Tube (Lower).....	∞A63004			Tube Nut; W/O Aux. Cooler.....			④A63011
Outlet Fitting To Trans. (Upper).....			A63006	Wire Retainer (Connectors).....			●A63110
Outlet Tube (Upper).....	∞A63004			<b>1992</b>			
Tube Nut.....			④A63011	<b>V-6 4.3 L ENG.; V-8 5.7 L ENG.</b>			
<b>1994</b>				Inlet Fitting To Trans.....			A63006
<b>V-6 4.3 L ENG.</b>				Inlet Tube.....	∞A63004		A63006
Connector From Rad.....			②A63006	Outlet Fitting To Trans.....	∞A63004		A63006
Inlet Fitting To Trans. (Lower).....			A63006	Outlet Tube.....			④A63011
Inlet Tube.....	∞A63004			Tube Nut.....			
Outlet Fitting To Trans. (Upper).....			A63006	<b>1991-1990</b>			
Outlet Tube (Upper).....	∞A63004			<b>V-6 4.3 L ENG.; V-8 5.7 L ENG.</b>			
Tube Nut.....			④A63011	Inlet Fitting To Trans.....			A63006
<b>V-8 5.7 L ENG.</b>				Inlet Tube.....	∞A63004		A63006
Aux. Cooler Inlet (Pass. Side);				Outlet Fitting To Trans.....	∞A63004		A63006
W/16-Bolt Trans. Pan (M30).....	A61217			Outlet Tube.....			④A63011
Aux. Cooler Inlet (Pass. Side);				Tube Nut.....			
W/17-Bolt Trans. Pan (MT1).....	A61172			<b>V-8 6.2 L DIESEL ENG.</b>			
Aux. Cooler Outlet (Driver Side);				Connector From Aux. Cooler.....			②A63017
W/16-Bolt Trans. Pan (M30).....	B61211			Inlet Fitting To Trans. (Upper).....			A63006
Aux. Cooler Outlet (Driver Side);				Inlet Tube.....	∞A63004		A63006
W/17-Bolt Trans. Pan (MT1).....	B61235			Outlet Fitting To Trans. (Lower).....			A63006
Connector From Aux. Cooler.....			②A63017	Outlet Tube.....	∞A63004		A63006
Inlet Fitting To Trans. (Upper).....			A63006	Tube Nut.....			●A63011
Inlet Tube (Upper).....	∞A63004			Wire Retainer (Connectors).....			●A63110
Outlet Fitting To Trans. (Lower).....			A63006	<b>1989</b>			
Outlet Tube (Lower); W/O Aux. Cooler.....	∞A63004			<b>V-6 2.8 L ENG.; V-6 4.3 L ENG.; V-8 5.7 L ENG.</b>			
Tube Nut; W/Aux. Cooler.....			②A63011	Inlet Fitting To Trans.....			A63006
Tube Nut; W/O Aux. Cooler.....			④A63011	Inlet Tube.....	∞A63004		A63006
Wire Retainer (Connectors).....			●A63110	Outlet Fitting To Trans.....	∞A63004		A63006
<b>V-8 6.5 L DIESEL ENG.</b>				Outlet Tube.....			④A63011
Aux. Cooler Inlet (Pass. Side).....	A61219			Tube Nut.....			
Aux. Cooler Outlet (Driver Side).....	B61165			<b>V-8 6.2 L DIESEL ENG.</b>			
Connector From Aux. Cooler.....			②A63017	Connector From Aux. Cooler.....			②A63017
Inlet Fitting To Trans. (Upper).....			A63006	Inlet Fitting To Trans. (Upper).....			A63006
Inlet Tube (Upper).....	∞A63004			Inlet Tube.....	∞A63004		A63006
Outlet Fitting To Trans. (Lower).....			A63006	Outlet Fitting To Trans. (Lower).....			A63006
Outlet Tube (Lower); W/O Aux. Cooler.....	∞A63004			Outlet Tube.....	∞A63004		A63006
Tube Nut; W/Aux. Cooler.....			②A63011	Tube Nut.....			●A63011
Tube Nut; W/O Aux. Cooler.....			④A63011	Wire Retainer (Connectors).....			●A63110
Wire Retainer (Connectors).....			●A63110	<b>1988</b>			
<b>1993</b>				<b>4-CYL. 2.5 L ENG.; V-6 2.8 L ENG.; V-6 4.3 L ENG.; V-8 5.7 L ENG.</b>			
<b>V-6 4.3 L ENG.</b>				Inlet Fitting To Trans.....			A63006
Inlet Fitting To Trans. (Lower).....			A63006	Inlet Tube.....	∞A63004		A63006
Inlet Tube (Lower).....	∞A63004			Outlet Fitting To Trans.....	∞A63004		A63006
Outlet Fitting To Trans. (Upper).....			A63006	Outlet Tube.....			④A63011
Outlet Tube (Upper).....	∞A63004			Tube Nut.....			
Tube Nut.....			④A63011	<b>V-8 6.2 L DIESEL ENG.</b>			
<b>V-8 5.7 L ENG.</b>				Connector From Aux. Cooler.....			②A63017
Aux. Cooler Inlet (Pass. Side);				Inlet Fitting To Trans. (Upper).....			A63006
W/16-Bolt Trans. Pan (M30).....	A61217			Inlet Tube.....	∞A63004		A63006
Aux. Cooler Inlet (Pass. Side);				Outlet Fitting To Trans. (Lower).....			A63006
W/17-Bolt Trans. Pan (MT1).....	A61172			Outlet Tube.....	∞A63004		A63006
Aux. Cooler Outlet (Driver Side);				Tube Nut.....			●A63011
W/16-Bolt Trans. Pan (M30).....	B61211			Wire Retainer (Connectors).....			●A63110
Aux. Cooler Outlet (Driver Side);				<b>1988</b>			
W/17-Bolt Trans. Pan (MT1).....	B61235			<b>4-CYL. 2.5 L ENG.; V-6 2.8 L ENG.; V-6 4.3 L ENG.; V-8 5.7 L ENG.</b>			
Connector From Aux. Cooler.....			②A63017	Inlet Fitting To Trans.....			A63006

② Two Required.  
③ Three Required.

④ Four Required.  
⑤ Five Required.

⑥ Six Required.  
⑦ Seven Required.

∞ Cut To Fit.  
● As Required.

See Pages 1 - 10 for Engine Oil Cooler Applications.

## Transmission Oil Cooler Assemblies for Passenger Cars &amp; Light Trucks

Application	Assembly Number	Hoses & Tubes	Connectors & Fittings	Application	Assembly Number	Hoses & Tubes	Connectors & Fittings
<b>CHEVROLET - Continued</b>				<b>CHEVROLET - Continued</b>			
<b>BLAZER - Continued</b>				<b>C &amp; K SERIES PICKUP - Continued</b>			
<b>1987</b>				<b>2000</b>			
<b>4-CYL. 2.5 L ENG.; V-6 2.8 L ENG.; V-8 5.0 L ENG.; V-8 5.7 L ENG.</b>				<b>V-8 5.7 L ENG.</b>			
Inlet Fitting To Trans.....			A63006	Aux. Cooler Inlet (Pass. Side); 3500HD .....	A61027		
Inlet Tube .....	≡A63004		A63006	Aux. Cooler Inlet (Pass. Side); Exc. 3500HD; W/16-Bolt Trans. Pan (M30) .....	B61056		
Outlet Fitting To Trans.....			A63006	Aux. Cooler Inlet (Pass. Side); Exc. 3500HD; W/17-Bolt Trans. Pan (MT1) .....	A61028		
Outlet Tube.....	≡A63004		ⓐA63011	Aux. Cooler Outlet (Driver Side); 3500HD .....	B61108		
Tube Nut.....			ⓐA63017	Aux. Cooler Outlet (Driver Side); Exc. 3500HD; W/16-Bolt Trans. Pan (M30) .....	B61058		
<b>V-8 6.2 L DIESEL ENG.</b>				<b>V-8 5.7 L ENG.</b>			
Connector From Aux. Cooler.....			ⓐA63017	Aux. Cooler Outlet (Driver Side); Exc. 3500HD; W/17-Bolt Trans. Pan (MT1) .....	B61029		
Inlet Fitting To Trans. (Upper).....			A63006	Connector From Aux. Cooler.....			ⓐA63019
Inlet Tube .....	≡A63004		A63006	Inlet (Upper); W/O Aux. Cooler; W/16-Bolt Trans. Pan (M30).....	B61057		
Outlet Fitting To Trans. (Lower).....			A63006	Inlet Fitting To Trans. (Upper); Service Item.....			A63007
Outlet Tube.....	≡A63004		●A63011	Inlet Fitting To Trans. (Upper); W/16-Bolt Trans. Pan (M30).....			A63007
Tube Nut.....			●A63110	Inlet Fitting To Trans. (Upper); W/Factory Inst. Fitting; W/17-Bolt Trans. Pan (MT1).....			A63006
Wire Retainer (Connectors).....				Inlet Fitting To Trans. Case (Upper); W/Factory Inst. Fitting; W/17-Bolt Trans. Pan (MT1) .....			A63027
<b>C &amp; K SERIES PICKUP</b>				<b>V-8 5.7 L ENG.</b>			
<b>2002-2001</b>				<b>V-8 6.5 L DIESEL ENG.</b>			
<b>V-8 6.5 L DIESEL ENG.</b>				Aux. Cooler Inlet (Pass. Side)..... A61027			
Aux. Cooler Inlet (Pass. Side).....	A61027			Aux. Cooler Outlet (Driver Side).....	B61108		
Aux. Cooler Outlet (Driver Side).....	B61108			Connector From Aux. Cooler.....			ⓐA63019
Connector From Aux. Cooler.....			ⓐA63019	Inlet Fitting To Trans. (Upper); Service Item.....			A63007
Inlet Fitting To Trans. (Upper); Service Item.....			A63007	Inlet Fitting To Trans. (Upper); W/Factory Inst. Fitting.....			A63006
Inlet Fitting To Trans. (Upper); W/Factory Inst. Fitting.....			A63006	Inlet Fitting To Trans. Case (Upper); W/Factory Inst. Fitting; W/17-Bolt Trans. Pan (MT1) .....			A63027
Inlet Fitting To Trans. Case (Upper); W/Factory Inst. Fitting.....			A63027	Inlet Tube (Upper); W/Aux. Cooler; Service Item; Remove Current Line & Trans. Fittings. Replace Using Bulk Tubing & Service Item Listed.....			≡A63005
Inlet Tube (Upper); Service Item; Remove Current Line & Trans. Fittings. Replace Using Bulk Tubing & Service Item Listed.....			≡A63005	Outlet (Lower); W/O Aux. Cooler; W/16-Bolt Trans. Pan (M30).....	B61055		
Outlet Fitting To Trans. (Lower).....			A63006	Outlet Fitting To Trans. (Lower); W/16-Bolt Trans. Pan (M30).....			A63007
Quick Connect Tube Fitting (Lower).....			A63021	Outlet Fitting To Trans. (Lower); W/17-Bolt Trans. Pan (MT1) .....			A63006
Quick Connect Tube Fitting (Upper).....			A63021	Quick Connect Tube Fitting (Lower).....			A63021
Tube Nut; Service Item.....			●A63013	Quick Connect Tube Fitting (Upper).....			A63021
Wire Retainer (Connectors & Fittings); W/3/8" Retainer.....			●A63098	Tube Nut; Service Item.....			ⓐA63013
Wire Retainer (Connectors & Fittings); W/5/8" Retainer.....			●A63099	Wire Retainer (Connectors & Fittings); W/3/8" Retainer.....			●A63098
<b>V-8 8.1 L ENG.</b>				<b>V-8 6.5 L DIESEL ENG.</b>			
Connector From Aux. Cooler.....			ⓐA63019	Aux. Cooler Inlet (Pass. Side); 3500HD .....	A61027		
Inlet Fitting To Trans. (Upper); Service Item.....			A63007	Aux. Cooler Inlet (Pass. Side); Exc. 3500HD .....	A61028		
Inlet Fitting To Trans. (Upper); W/Factory Inst. Fitting.....			A63006	Aux. Cooler Outlet (Driver Side); 3500HD .....	B61108		
Inlet Fitting To Trans. Case (Upper); W/Factory Inst. Fitting.....			A63027	Aux. Cooler Outlet (Driver Side); Exc. 3500HD .....	B61107		
Inlet Tube (Upper); Service Item; Remove Current Line & Trans. Fittings. Replace Using Bulk Tubing & Service Item Listed.....			≡A63005	Connector From Aux. Cooler.....			ⓐA63019
Outlet Fitting To Trans. (Lower).....			A63006	Inlet Fitting To Trans. (Upper); Service Item.....			A63007
Quick Connect Tube Fitting (Lower).....			A63021	Inlet Fitting To Trans. (Upper); W/Factory Inst. Fitting.....			A63006
Quick Connect Tube Fitting (Upper).....			A63021	Inlet Fitting To Trans. Case (Upper).....			A63027
Tube Nut; Service Item.....			ⓐA63013	Inlet Tube (Upper); Service Item; Remove Current Line & Trans. Fittings. Replace Using Bulk Tubing & Service Item Listed.....			≡A63005
Wire Retainer (Connectors & Fittings); W/3/8" Retainer.....			●A63098	Outlet Fitting To Trans. (Lower).....			A63006
Wire Retainer (Connectors & Fittings); W/5/8" Retainer.....			●A63099				

ⓐ Two Required.  
ⓑ Three Required.

ⓐ Four Required.  
ⓑ Five Required.

ⓐ Six Required.  
ⓑ Seven Required.

≡ Cut To Fit.  
● As Required.

See Pages 1 - 10 for Engine Oil Cooler Applications.

# Transmission Oil Cooler Assemblies for Passenger Cars & Light Trucks

Application	Assembly Number	Hoses & Tubes	Connectors & Fittings	Application	Assembly Number	Hoses & Tubes	Connectors & Fittings
<b>CHEVROLET - Continued</b>				<b>CHEVROLET - Continued</b>			
<b>C &amp; K SERIES PICKUP - Continued</b>				<b>C &amp; K SERIES PICKUP - Continued</b>			
<b>2000 - Continued</b>				<b>1999 - Continued</b>			
<b>V-8 6.5 L DIESEL ENG. - Continued</b>				<b>V-8 5.7 L ENG. - Continued</b>			
Quick Connect Tube Fitting (Lower)			A63021	Aux. Cooler Outlet (Driver Side); Exc. 3500HD; W/17-Bolt Trans. Pan (MT1)	B61029		②A63019
Quick Connect Tube Fitting (Upper)			A63021	Connector From Aux. Cooler			
Tube Nut; Service Item			②A63013	Inlet (Upper); W/O Aux. Cooler; W/16-Bolt Trans. Pan (M30)	B61057		
Wire Retainer (Connectors & Fittings); W/3/8" Retainer			●A63098	Inlet Fitting To Trans. (Upper); Service Item			A63007
Wire Retainer (Connectors & Fittings); W/5/8" Retainer			●A63099	Inlet Fitting To Trans. (Upper); W/16-Bolt Trans. Pan (M30)			A63007
<b>V-8 7.4 L ENG.</b>				Inlet Fitting To Trans. (Upper); W/Factory Inst. Fitting; W/17-Bolt Trans. Pan (MT1)			
Aux. Cooler Inlet (Pass. Side); 3500HD	A61027			Inlet Fitting To Trans. Case (Upper); W/Factory Inst. Fitting; W/17-Bolt Trans. Pan (MT1)			A63006
Aux. Cooler Inlet (Pass. Side); Exc. 3500HD	B61025			Quick Connect Tube Fitting (Lower)			A63027
Aux. Cooler Outlet (Driver Side); 3500HD	B61108			Outlet (Lower); W/O Aux. Cooler; W/16-Bolt Trans. Pan (M30)	B61055		
Aux. Cooler Outlet (Driver Side); Exc. 3500HD	B61026			Outlet Fitting To Trans. (Lower); W/17-Bolt Trans. Pan (MT1)			A63007
Connector From Aux. Cooler			②A63019	Quick Connect Tube Fitting (Lower)			A63006
Inlet Fitting To Trans. (Upper); Service Item			A63007	Quick Connect Tube Fitting (Upper)			A63021
Inlet Fitting To Trans. (Upper); W/Factory Inst. Fitting			A63006	Tube Nut; Service Item			②A63013
Inlet Fitting To Trans. Case (Upper)			A63027	Wire Retainer (Connectors & Fittings); W/3/8" Retainer			●A63098
Inlet Tube (Upper); Service Item; Remove Current Line & Trans. Fittings. Replace Using Bulk Tubing & Service Item Listed		≈A63005		Wire Retainer (Connectors & Fittings); W/5/8" Retainer			●A63099
Outlet Fitting To Trans. (Lower)			A63006	<b>V-8 6.5 L DIESEL ENG.</b>			
Quick Connect Tube Fitting (Lower)			A63021	Aux. Cooler Inlet (Pass. Side); 3500HD	A61027		
Quick Connect Tube Fitting (Upper); W/Factory Inst. Fitting			A63021	Aux. Cooler Inlet (Pass. Side); Exc. 3500HD	A61028		
Tube Nut; Service Item			②A63013	Aux. Cooler Outlet (Driver Side); 3500HD	B61108		
Wire Retainer (Connectors & Fittings); W/3/8" Retainer			●A63098	Aux. Cooler Outlet (Driver Side); Exc. 3500HD	B61107		
Wire Retainer (Connectors & Fittings); W/5/8" Retainer			●A63099	Connector From Aux. Cooler			②A63019
<b>1999</b>				Inlet Fitting To Trans. (Upper); Service Item			
<b>V-8 5.0 L ENG.</b>				Inlet Fitting To Trans. (Upper); W/Factory Inst. Fitting			
Inlet (Upper); W/140A. Gen.	B61057			Inlet Fitting To Trans. Case (Upper)			A63027
Inlet (Upper); W/O 140A. Gen.	B61059		A63007	Inlet Tube (Upper); Service Item; Remove Current Line & Trans. Fittings. Replace Using Bulk Tubing & Service Item Listed		≈A63005	A63006
Inlet Fitting To Trans. (Upper)			A63007	Outlet Fitting To Trans. (Lower)			A63021
Outlet (Lower); W/140A. Gen.	B61055			Quick Connect Tube Fitting (Lower)			A63021
Outlet (Lower); W/O 140A. Gen.	B61060			Quick Connect Tube Fitting (Upper)			②A63013
Outlet Fitting To Trans. (Lower)			A63007	Tube Nut; Service Item			A63007
Quick Connect Tube Fitting (Lower)			A63021	Wire Retainer (Connectors & Fittings); W/3/8" Retainer			●A63098
Quick Connect Tube Fitting (Upper)			A63021	Wire Retainer (Connectors & Fittings); W/5/8" Retainer			●A63099
Wire Retainer (Fittings); W/3/8" Retainer			●A63098	<b>V-8 5.7 L ENG.</b>			
Wire Retainer (Fittings); W/5/8" Retainer			●A63099	Aux. Cooler Inlet (Pass. Side); 3500HD	A61027		
<b>V-8 5.7 L ENG.</b>				Aux. Cooler Inlet (Pass. Side); Exc. 3500HD; W/16-Bolt Trans. Pan (M30)			
Aux. Cooler Inlet (Pass. Side); 3500HD	A61027			Aux. Cooler Outlet (Driver Side); 3500HD	B61108		
Aux. Cooler Inlet (Pass. Side); Exc. 3500HD; W/16-Bolt Trans. Pan (M30)	B61056			Aux. Cooler Outlet (Driver Side); Exc. 3500HD	B61107		
Aux. Cooler Inlet (Pass. Side); Exc. 3500HD; W/17-Bolt Trans. Pan (MT1)	A61028			Connector From Aux. Cooler			②A63019
Aux. Cooler Outlet (Driver Side); 3500HD	B61108			Inlet Fitting To Trans. (Upper); Service Item			A63007
Aux. Cooler Outlet (Driver Side); Exc. 3500HD; W/16-Bolt Trans. Pan (M30)	B61058			Inlet Fitting To Trans. (Upper); W/Factory Inst. Fitting			A63006
				Inlet Fitting To Trans. Case (Upper)			
				Inlet Tube (Upper); Service Item; Remove Current Line & Trans. Fittings. Replace Using Bulk Tubing & Service Item Listed			
				Outlet Fitting To Trans. (Lower)			
				Quick Connect Tube Fitting (Lower)			
				Quick Connect Tube Fitting (Upper)			
				Tube Nut; Service Item			
				Wire Retainer (Connectors & Fittings); W/3/8" Retainer			
				Wire Retainer (Connectors & Fittings); W/5/8" Retainer			
				<b>V-8 7.4 L ENG.</b>			
				Aux. Cooler Inlet (Pass. Side); 3500HD			
				A61027			

② Two Required.  
③ Three Required.

④ Four Required.  
⑤ Five Required.

⑥ Six Required.  
⑦ Seven Required.

≈ Cut To Fit.  
● As Required.

See Pages 1 - 10 for Engine Oil Cooler Applications.

## Transmission Oil Cooler Assemblies for Passenger Cars &amp; Light Trucks

Application	Assembly Number	Hoses & Tubes	Connectors & Fittings	Application	Assembly Number	Hoses & Tubes	Connectors & Fittings
<b>CHEVROLET - Continued</b>				<b>CHEVROLET - Continued</b>			
<b>C &amp; K SERIES PICKUP - Continued</b>				<b>C &amp; K SERIES PICKUP - Continued</b>			
<b>1999 - Continued</b>				<b>1998 - Continued</b>			
<b>V-8 7.4 L ENG. - Continued</b>				<b>V-8 5.7 L ENG. - Continued</b>			
Aux. Cooler Inlet (Pass. Side); Exc. 3500HD .....	B61025			Aux. Cooler Outlet (Driver Side); Exc. 3500HD; W/16-Bolt Trans. Pan (M30) .....	B61058		
Aux. Cooler Outlet (Driver Side); 3500HD .....	B61108			Aux. Cooler Outlet (Driver Side); Exc. 3500HD; W/17-Bolt Trans. Pan (MT1) .....	B61029		
Aux. Cooler Outlet (Driver Side); Exc. 3500HD .....	B61026			Connector From Aux. Cooler .....			②A63019
Connector From Aux. Cooler .....			②A63019	Inlet (Upper); W/O Aux. Cooler; W/16-Bolt Trans. Pan (M30) .....	B61057		
Inlet Fitting To Trans. (Upper); Service Item .....			A63007	Inlet Fitting To Trans. (Upper); Service Item .....			A63007
Inlet Fitting To Trans. (Upper); W/Factory Inst. Fitting .....			A63006	Inlet Fitting To Trans. (Upper); W/16-Bolt Trans. Pan (M30) .....			A63007
Inlet Fitting To Trans. Case (Upper) .....			A63027	Inlet Fitting To Trans. (Upper); W/Factory Inst. Fitting; W/17-Bolt Trans. Pan (MT1) .....			A63006
Inlet Tube (Upper); Service Item; Remove Current Line & Trans. Fittings. Replace Using Bulk Tubing & Service Item Listed .....		≠A63005	A63006	Inlet Fitting To Trans. Case (Upper); W/Factory Inst. Fitting; W/17-Bolt Trans. Pan (MT1) .....			A63027
Outlet Fitting To Trans. (Lower) .....			A63021	Inlet Tube (Upper); W/Aux. Cooler; Service Item; Remove Current Line & Trans. Fittings. Replace Using Bulk Tubing & Service Item Listed .....		≠A63005	
Quick Connect Tube Fitting (Lower) .....			A63021	Outlet (Lower); W/O Aux. Cooler; W/16-Bolt Trans. Pan (M30) .....	B61055		
Quick Connect Tube Fitting (Upper); W/Factory Inst. Fitting .....			A63021	Outlet Fitting To Trans. (Lower); W/16-Bolt Trans. Pan (M30) .....			A63007
Tube Nut; Service Item .....			②A63013	Outlet Fitting To Trans. (Lower); W/17-Bolt Trans. Pan (MT1) .....			A63006
Wire Retainer (Connectors & Fittings); W/3/8" Retainer .....			●A63098	Quick Connect Tube Fitting (Lower) .....			A63021
Wire Retainer (Connectors & Fittings); W/5/8" Retainer .....			●A63099	Quick Connect Tube Fitting (Upper) .....			A63021
				Tube Nut; Service Item .....			●A63013
				Wire Retainer (Connectors & Fittings); W/3/8" Retainer .....			●A63098
				Wire Retainer (Connectors & Fittings); W/5/8" Retainer .....			●A63099
<b>1998</b>				<b>V-8 6.5 L DIESEL ENG.</b>			
<b>V-6 4.3 L ENG.</b>				Aux. Cooler Inlet (Pass. Side); 3500HD .....			
Inlet (Upper) .....	B61059		A63007	Aux. Cooler Inlet (Pass. Side); Exc. 3500HD .....	A61027		
Inlet Fitting To Trans. (Upper) .....			A63007	Aux. Cooler Outlet (Driver Side); 3500HD .....	A61028		
Outlet (Lower) .....	B61060		A63021	Aux. Cooler Outlet (Driver Side); Exc. 3500HD .....	B61108		
Outlet Fitting To Trans. (Lower) .....			A63021	Connector From Aux. Cooler .....	B61107		
Quick Connect Tube Fitting (Lower) .....			●A63098	Inlet Fitting To Trans. (Upper); Service Item .....			②A63019
Quick Connect Tube Fitting (Upper) .....			●A63099	Inlet Fitting To Trans. (Upper); W/Factory Inst. Fitting .....			A63007
Wire Retainer (Fittings); W/3/8" Retainer .....				Inlet Fitting To Trans. Case (Upper) .....			A63006
Wire Retainer (Fittings); W/5/8" Retainer .....				Inlet Tube (Upper); Service Item; Remove Current Line & Trans. Fittings. Replace Using Bulk Tubing & Service Item Listed .....		≠A63005	A63027
				Outlet Fitting To Trans. (Lower) .....			A63006
				Quick Connect Tube Fitting (Lower) .....			A63021
				Quick Connect Tube Fitting (Upper) .....			A63021
				Tube Nut; Service Item .....			②A63013
				Wire Retainer (Connectors & Fittings); W/3/8" Retainer .....			●A63098
				Wire Retainer (Connectors & Fittings); W/5/8" Retainer .....			●A63099
<b>V-8 5.0 L ENG.</b>							
Inlet (Upper); W/140A. Gen. ....	B61057		A63007				
Inlet (Upper); W/O 140A. Gen. ....	B61059		A63007				
Inlet Fitting To Trans. (Upper) .....			A63007				
Outlet (Lower); W/140A. Gen. ....	B61055		A63021				
Outlet (Lower); W/O 140A. Gen. ....	B61060		A63021				
Outlet Fitting To Trans. (Lower) .....			●A63098				
Quick Connect Tube Fitting (Lower) .....			●A63099				
Quick Connect Tube Fitting (Upper) .....							
Wire Retainer (Fittings); W/3/8" Retainer .....							
Wire Retainer (Fittings); W/5/8" Retainer .....							
<b>V-8 5.7 L ENG.</b>							
Aux. Cooler Inlet (Pass. Side); 3500HD .....	A61027						
Aux. Cooler Inlet (Pass. Side); Exc. 3500HD; W/16-Bolt Trans. Pan (M30) .....	B61056						
Aux. Cooler Inlet (Pass. Side); Exc. 3500HD; W/17-Bolt Trans. Pan (MT1) .....	A61028						
Aux. Cooler Outlet (Driver Side); 3500HD .....	B61108						

② Two Required.  
③ Three Required.

④ Four Required.  
⑤ Five Required.

⑥ Six Required.  
⑦ Seven Required.

≠ Cut To Fit.  
● As Required.

See Pages 1 - 10 for Engine Oil Cooler Applications.

# Transmission Oil Cooler Assemblies for Passenger Cars & Light Trucks

Application	Assembly Number	Hoses & Tubes	Connectors & Fittings	Application	Assembly Number	Hoses & Tubes	Connectors & Fittings
<b>CHEVROLET - Continued</b> <b>C &amp; K SERIES PICKUP - Continued</b> <b>1998 - Continued</b> <b>V-8 7.4 L ENG.</b> Aux. Cooler Inlet (Pass. Side); 3500HD ..... <b>A61027</b> Aux. Cooler Inlet (Pass. Side); Exc. 3500HD ..... <b>B61025</b> Aux. Cooler Outlet (Driver Side); 3500HD ..... <b>B61108</b> Aux. Cooler Outlet (Driver Side); Exc. 3500HD ..... <b>B61026</b> Connector From Aux. Cooler ..... <b>②A63019</b> Inlet Fitting To Trans. (Upper); Ser- vice Item ..... <b>A63007</b> Inlet Fitting To Trans. (Upper); W/Factory Inst. Fitting ..... <b>A63006</b> Inlet Fitting To Trans. Case (Up- per) ..... <b>A63027</b> Inlet Tube (Upper); Service Item; Remove Current Line & Trans. Fittings. Replace Using Bulk Tubing & Service Item Listed ..... <b>≧A63005</b> Outlet Fitting To Trans. (Lower) ..... <b>A63006</b> Quick Connect Tube Fitting (Low- er) ..... <b>A63021</b> Quick Connect Tube Fitting (Up- per); W/Factory Inst. Fitting ..... <b>A63021</b> Tube Nut; Service Item ..... <b>④A63013</b> Wire Retainer (Connectors & Fit- tings); W/3/8" Retainer ..... <b>●A63098</b> Wire Retainer (Connectors & Fit- tings); W/5/8" Retainer ..... <b>●A63099</b>  <b>1997</b> <b>V-6 4.3 L ENG.</b> Inlet Fitting To Trans. (Upper); Ser- vice Item ..... <b>A63007</b> Inlet Tube (Upper); Service Item; Remove Current Line & Trans. Fittings. Replace Using Bulk Tubing & Service Item Listed ..... <b>≧A63005</b> Outlet Fitting To Trans. (Lower); Service Item ..... <b>A63007</b> Outlet Tube (Lower); Service Item; Remove Current Line & Trans. Fittings. Replace Using Bulk Tubing & Service Item Listed ..... <b>≧A63005</b> Quick Connect Tube Fitting (Low- er); W/Factory Inst. Fitting ..... <b>A63021</b> Quick Connect Tube Fitting (Up- per); W/Factory Inst. Fitting ..... <b>A63021</b> Tube Nut; Service Item ..... <b>④A63013</b> Wire Retainer (Fittings); W/3/8" Re- tainer ..... <b>●A63098</b> Wire Retainer (Fittings); W/5/8" Re- tainer ..... <b>●A63099</b>  <b>V-8 5.0 L ENG.</b> Inlet Fitting To Trans. (Upper); Ser- vice Item ..... <b>A63007</b> Inlet Fitting To Trans. (Upper); W/Factory Inst. Fitting ..... <b>A63006</b> Inlet Tube (Upper); Service Item; Remove Current Line & Trans. Fittings. Replace Using Bulk Tubing & Service Item Listed ..... <b>≧A63005</b> Outlet Fitting To Trans. (Lower); Service Item ..... <b>A63007</b> Outlet Fitting To Trans. (Lower); W/Factory Inst. Fitting ..... <b>A63006</b> Outlet Tube (Lower); Service Item; Remove Current Line & Trans. Fittings. Replace Using Bulk Tubing & Service Item Listed ..... <b>≧A63005</b>				<b>CHEVROLET - Continued</b> <b>C &amp; K SERIES PICKUP - Continued</b> <b>1997 - Continued</b> <b>V-8 5.0 L ENG. - Continued</b> Quick Connect Tube Fitting (Low- er); W/Factory Inst. Fitting ..... <b>A63021</b> Quick Connect Tube Fitting (Up- per); W/Factory Inst. Fitting ..... <b>A63021</b> Tube Nut; Service Item ..... <b>④A63013</b> Wire Retainer (Fittings); W/3/8" Re- tainer ..... <b>●A63098</b> Wire Retainer (Fittings); W/5/8" Re- tainer ..... <b>●A63099</b>  <b>V-8 5.7 L ENG.</b> Aux. Cooler Inlet (Pass. Side); 3500HD ..... <b>A61027</b> Aux. Cooler Inlet (Pass. Side); Exc. 3500HD; W/16-Bolt Trans. Pan (M30) ..... <b>B61240</b> Aux. Cooler Inlet (Pass. Side); Exc. 3500HD; W/17-Bolt Trans. Pan (MT1) ..... <b>A61028</b> Aux. Cooler Outlet (Driver Side); 3500HD ..... <b>B61108</b> Aux. Cooler Outlet (Driver Side); Exc. 3500HD; W/16-Bolt Trans. Pan (M30) ..... <b>B61252</b> Aux. Cooler Outlet (Driver Side); Exc. 3500HD; W/17-Bolt Trans. Pan (MT1) ..... <b>B61029</b> Connector From Aux. Cooler ..... <b>②A63019</b> Inlet Fitting To Trans. (Upper); Ser- vice Item ..... <b>A63007</b> Inlet Fitting To Trans. (Upper); W/16-Bolt Trans. Pan (M30) ..... <b>A63007</b> Inlet Fitting To Trans. (Upper); W/Factory Inst. Fitting; W/17-Bolt Trans. Pan (MT1) ..... <b>A63006</b> Inlet Fitting To Trans. Case (Up- per); W/Factory Inst. Fitting; W/17-Bolt Trans. Pan (MT1) ..... <b>A63027</b> Inlet Tube (Upper); Service Item; Remove Current Line & Trans. Fittings. Replace Using Bulk Tubing & Service Item Listed ..... <b>≧A63005</b> Outlet Fitting To Trans. (Lower); W/16-Bolt Trans. Pan (M30) ..... <b>A63007</b> Outlet Fitting To Trans. (Lower); W/17-Bolt Trans. Pan (MT1) ..... <b>A63006</b> Quick Connect Tube Fitting (Low- er) ..... <b>A63021</b> Quick Connect Tube Fitting (Up- per) ..... <b>A63021</b> Tube Nut; Service Item ..... <b>②A63013</b> Wire Retainer (Connectors & Fit- tings); W/3/8" Retainer ..... <b>●A63098</b> Wire Retainer (Connectors & Fit- tings); W/5/8" Retainer ..... <b>●A63099</b>  <b>V-8 6.5 L DIESEL ENG.</b> Aux. Cooler Inlet (Pass. Side); 3500HD ..... <b>A61027</b> Aux. Cooler Inlet (Pass. Side); Exc. 3500HD ..... <b>A61028</b> Aux. Cooler Outlet (Driver Side); 3500HD ..... <b>B61108</b> Aux. Cooler Outlet (Driver Side); Exc. 3500HD ..... <b>B61107</b> Connector From Aux. Cooler ..... <b>②A63019</b> Inlet Fitting To Trans. (Upper); Ser- vice Item ..... <b>A63007</b> Inlet Fitting To Trans. (Upper); W/Factory Inst. Fitting ..... <b>A63006</b> Inlet Fitting To Trans. Case (Up- per) ..... <b>A63027</b>			

② Two Required.  
 ③ Three Required.

④ Four Required.  
 ⑤ Five Required.

⑥ Six Required.  
 ⑦ Seven Required.

≧ Cut To Fit.  
 ● As Required.

See Pages 1 - 10 for Engine Oil Cooler Applications.

Product Section

Troubleshooting

EOC Applications

TOC Applications

Numerical Listing

Manufacturers'  
Part Numbers

End Fittings

Illustrations

## Transmission Oil Cooler Assemblies for Passenger Cars &amp; Light Trucks

Application	Assembly Number	Hoses & Tubes	Connectors & Fittings	Application	Assembly Number	Hoses & Tubes	Connectors & Fittings
<b>CHEVROLET - Continued</b>				<b>CHEVROLET - Continued</b>			
<b>C &amp; K SERIES PICKUP - Continued</b>				<b>C &amp; K SERIES PICKUP - Continued</b>			
<b>1997 - Continued</b>				<b>1996 - Continued</b>			
<b>V-8 6.5 L DIESEL ENG. - Continued</b>				<b>V-8 5.7 L ENG. - Continued</b>			
Inlet Tube (Upper); Service Item; Remove Current Line & Trans. Fittings. Replace Using Bulk Tubing & Service Item Listed.....			≈A63005	Aux. Cooler Inlet (Pass. Side); Exc. 3500HD; W/17-Bolt Trans. Pan (MT1).....	A61028		
Outlet Fitting To Trans. (Lower).....			A63006	Aux. Cooler Outlet (Driver Side); Exc. 3500HD; W/16-Bolt Trans. Pan (M30).....	B61252		
Quick Connect Tube Fitting (Lower) .....			A63021	Aux. Cooler Outlet (Driver Side); Exc. 3500HD; W/17-Bolt Trans. Pan (MT1).....	B61253		
Quick Connect Tube Fitting (Upper) .....			A63021	Connector From Aux. Cooler.....			②A63019
Tube Nut; Service Item.....			②A63013	Inlet Fitting To Trans. (Upper); Ser- vice Item.....			A63007
Wire Retainer (Connectors & Fit- tings); W/3/8" Retainer.....			●A63098	Inlet Fitting To Trans. (Upper); W/16-Bolt Trans. Pan (M30).....			A63007
Wire Retainer (Connectors & Fit- tings); W/5/8" Retainer.....			●A63099	Inlet Fitting To Trans. (Upper); W/Factory Inst. Fitting; W/17-Bolt Trans. Pan (MT1).....			A63006
<b>V-8 7.4 L ENG.</b>				<b>V-8 6.5 L DIESEL ENG.</b>			
Aux. Cooler Inlet (Pass. Side); 3500HD.....	A61027			Aux. Cooler Inlet (Pass. Side); 3500HD.....	A61027		
Aux. Cooler Inlet (Pass. Side); Exc. 3500HD.....	B61025			Connector From Aux. Cooler.....			②A63019
Aux. Cooler Outlet (Driver Side); 3500HD.....	B61108			Inlet Fitting To Trans. (Upper); Ser- vice Item.....			A63007
Aux. Cooler Outlet (Driver Side); Exc. 3500HD.....	B61026			Inlet Fitting To Trans. (Upper); W/Factory Inst. Fitting.....			A63006
Connector From Aux. Cooler.....			②A63019	Inlet Fitting To Trans. Case (Up- per).....			A63027
Inlet Fitting To Trans. (Upper); Ser- vice Item.....			A63007	Inlet Tube (Upper); Service Item; Remove Current Line & Trans. Fittings. Replace Using Bulk Tubing & Service Item Listed.....			≈A63005
Inlet Fitting To Trans. (Upper); W/Factory Inst. Fitting.....			A63006	Outlet Fitting To Trans. (Lower).....			A63006
Inlet Fitting To Trans. Case (Up- per).....			A63027	Quick Connect Tube Fitting (Low- er).....			A63021
Quick Connect Tube Fitting (Upper); W/Factory Inst. Fitting.....			A63021	Quick Connect Tube Fitting (Up- per).....			A63021
Tube Nut; Service Item.....			②A63013	Tube Nut; Service Item.....			②A63013
Wire Retainer (Connectors & Fit- tings); W/3/8" Retainer.....			●A63098	Wire Retainer (Connectors & Fit- tings); W/3/8" Retainer.....			●A63098
Wire Retainer (Connectors & Fit- tings); W/5/8" Retainer.....			●A63099	Wire Retainer (Connectors & Fit- tings); W/5/8" Retainer.....			●A63099
<b>1996</b>				<b>V-8 5.7 L ENG.</b>			
<b>V-6 4.3 L ENG.; V-8 5.0 L ENG.</b>				Aux. Cooler Inlet (Pass. Side); 3500HD.....			
Inlet Fitting To Trans. (Upper); Ser- vice Item.....			A63007	Connector From Aux. Cooler.....			②A63019
Inlet Tube (Upper); Service Item; Remove Current Line & Trans. Fittings. Replace Using Bulk Tubing & Service Item Listed.....			≈A63005	Inlet Fitting To Trans. (Upper); Ser- vice Item.....			A63007
Outlet Fitting To Trans. (Lower); Service Item.....			A63007	Inlet Fitting To Trans. (Upper); W/Factory Inst. Fitting.....			A63006
Outlet Tube (Lower); Service Item; Remove Current Line & Trans. Fittings. Replace Using Bulk Tubing & Service Item Listed.....			≈A63005	Inlet Tube (Upper); Service Item; Remove Current Line & Trans. Fittings. Replace Using Bulk Tubing & Service Item Listed.....			≈A63005
Quick Connect Tube Fitting; W/Factory Inst. Fitting.....			②A63021	Outlet Fitting To Trans. (Lower); Service Item.....			A63007
Tube Nut; Service Item.....			④A63013	Outlet Fitting To Trans. (Lower); W/Factory Inst. Fitting.....			A63006
Wire Retainer (Fittings).....			●A63098	Outlet Tube (Lower); W/O Aux. Cooler; Service Item; Remove Current Line & Trans. Fittings. Replace Using Bulk Tubing & Service Item Listed.....			≈A63005
<b>V-8 5.7 L ENG.</b>				Quick Connect Tube Fitting (Low- er).....			
Aux. Cooler Inlet (Pass. Side); 3500HD.....	A61027			Quick Connect Tube Fitting (Up- per).....			A63021
Aux. Cooler Inlet (Pass. Side); Exc. 3500HD; W/16-Bolt Trans. Pan (M30).....	B61240			Tube Nut; Service Item.....			②A63013
				Wire Retainer (Connectors & Fit- tings); W/3/8" Retainer.....			
				●A63098			
				Wire Retainer (Connectors & Fit- tings); W/5/8" Retainer.....			
				●A63099			
				<b>V-8 7.4 L ENG.</b>			
				Aux. Cooler Inlet (Pass. Side); 3500HD.....			
				A61027			
				Aux. Cooler Inlet (Pass. Side); Exc. 3500HD.....			
				B61025			

② Two Required.  
③ Three Required.

④ Four Required.  
⑤ Five Required.

⑥ Six Required.  
⑦ Seven Required.

≈ Cut To Fit.  
● As Required.

See Pages 1 - 10 for Engine Oil Cooler Applications.



# Transmission Oil Cooler Assemblies for Passenger Cars & Light Trucks

Application	Assembly Number	Hoses & Tubes	Connectors & Fittings	Application	Assembly Number	Hoses & Tubes	Connectors & Fittings
<b>CHEVROLET - Continued</b>				<b>CHEVROLET - Continued</b>			
<b>C &amp; K SERIES PICKUP - Continued</b>				<b>C &amp; K SERIES PICKUP - Continued</b>			
<b>1996 - Continued</b>				<b>1995-1994 - Continued</b>			
<b>V-8 7.4 L ENG. - Continued</b>				<b>V-8 7.4 L ENG.</b>			
Aux. Cooler Outlet (Driver Side); Exc. 3500HD.....	B61254			Aux. Cooler Inlet (Pass. Side); Exc. 3500HD .....	B61169		
Connector From Aux. Cooler.....			②A63019	Aux. Cooler Outlet (Driver Side); 3500HD .....	B61109		
Inlet Fitting To Trans. (Upper).....			A63007	Aux. Cooler Outlet (Pass. Side); Exc. 3500HD .....	B61159		
Inlet Tube (Upper); Service Item; Remove Current Line & Trans. Fittings. Replace Using Bulk Tubing & Service Item Listed.....		≡A63005		Connector "O" Ring.....			●A63091
Outlet Fitting To Trans. (Upper).....			A63007	Connector From Aux. Cooler.....		≡A63004	②A63017
Quick Connect Tube Fitting (Low- er).....			A63021	Inlet (Upper).....			A63006
Quick Connect Tube Fitting (Up- per).....			A63021	Inlet Fitting To Trans. (Upper).....			A63006
Tube Nut; Service Item.....			●A63013	Outlet Fitting To Trans. (Lower).....			●A63011
Wire Retainer (Connectors & Fit- tings); W/3/8" Retainer.....			●A63098	Tube Nut.....			●A63110
Wire Retainer (Connectors & Fit- tings); W/5/8" Retainer.....			●A63099	<b>1993</b>			
				<b>V-6 4.3 L ENG.; V-8 5.0 L ENG.</b>			
<b>1995-1994</b>				Inlet (Lower).....	≡A63004		A63006
<b>V-6 4.3 L ENG.; V-8 5.0 L ENG.</b>				Inlet Fitting To Trans. (Lower).....			A63006
Inlet (Upper).....		≡A63004		Outlet (Upper).....	≡A63004		A63006
Inlet Fitting To Trans. (Upper).....			A63006	Outlet Fitting To Trans. (Upper).....			A63006
Outlet (Lower).....		≡A63004		Tube Nut.....			④A63011
Outlet Fitting To Trans. (Lower).....			A63006	<b>V-8 5.7 L ENG.</b>			
Tube Nut.....			④A63011	Aux. Cooler Inlet (Pass. Side); Exc. 3500HD; W/16-Bolt Trans. Pan (M30) .....	A61217		
<b>V-8 5.7 L ENG.</b>				Aux. Cooler Inlet (Pass. Side); Exc. 3500HD; W/17-Bolt Trans. Pan (MT1) .....	A61172		
Aux. Cooler Inlet (Pass. Side); Exc. 3500HD; W/16-Bolt Trans. Pan (M30) .....	A61217			Aux. Cooler Outlet (Driver Side); Exc. 3500HD; W/16-Bolt Trans. Pan (M30) .....	B61211		
Aux. Cooler Inlet (Pass. Side); Exc. 3500HD; W/17-Bolt Trans. Pan (MT1) .....	A61172			Aux. Cooler Outlet (Driver Side); Exc. 3500HD; W/17-Bolt Trans. Pan (MT1) .....	B61235		
Aux. Cooler Outlet (Driver Side); 3500HD .....	B61109			Connector "O" Ring.....			●A63091
Aux. Cooler Outlet (Driver Side); Exc. 3500HD; W/16-Bolt Trans. Pan (M30) .....	B61211			Connector From Aux. Cooler.....			②A63017
Aux. Cooler Outlet (Driver Side); Exc. 3500HD; W/17-Bolt Trans. Pan (MT1) .....	B61235			Inlet (Upper); W/Aux. Cooler.....		≡A63004	
Connector "O" Ring.....			●A63091	Inlet (Upper); W/O Aux. Cooler.....		≡A63004	
Connector From Aux. Cooler.....			②A63017	Inlet Fitting To Trans. (Upper).....			A63006
Inlet (Upper); W/Aux. Cooler.....		≡A63004		Outlet (Lower); W/O Aux. Cooler....		≡A63004	
Inlet (Upper); W/O Aux. Cooler.....		≡A63004		Outlet Fitting To Trans. (Lower).....			A63006
Inlet Fitting To Trans. (Upper).....			A63006	Tube Nut.....			●A63011
Outlet (Lower); W/O Aux. Cooler....		≡A63004		Wire Retainer (Connectors) .....			●A63110
Outlet Fitting To Trans. (Lower).....			A63006	<b>V-8 6.2 L DIESEL ENG.</b>			
Tube Nut.....			●A63011	Inlet (Upper).....		≡A63004	
Wire Retainer (Connectors) .....			●A63110	Inlet Fitting To Trans. (Upper).....			A63006
<b>V-8 6.5 L DIESEL ENG.</b>				Outlet (Lower).....		≡A63004	
Aux. Cooler Inlet (Pass. Side); W/16-Bolt Trans. Pan (M30).....	B61218			Outlet Fitting To Trans. (Lower).....			A63006
Aux. Cooler Inlet (Pass. Side); W/17-Bolt Trans. Pan (MT1).....	A61219			Tube Nut.....			A63006
Aux. Cooler Outlet (Driver Side); 3500HD .....	B61109			Wire Retainer (Connectors) .....			④A63011
Aux. Cooler Outlet (Driver Side); W/16-Bolt Trans. Pan (M30).....	B61212			<b>V-8 6.5 L DIESEL ENG.</b>			
Aux. Cooler Outlet (Driver Side); W/17-Bolt Trans. Pan (MT1).....	B61165			Aux. Cooler Inlet (Pass. Side); W/16-Bolt Trans. Pan (M30).....	B61218		
Connector "O" Ring.....			●A63091	Aux. Cooler Inlet (Pass. Side); W/17-Bolt Trans. Pan (MT1).....	A61219		
Connector From Aux. Cooler.....			②A63017	Aux. Cooler Outlet (Driver Side); 3500HD .....	B61109		
Inlet (Upper).....		≡A63004		Aux. Cooler Outlet (Driver Side); W/16-Bolt Trans. Pan (M30).....	B61212		
Inlet Fitting To Trans. (Upper).....			A63006	Aux. Cooler Outlet (Driver Side); W/17-Bolt Trans. Pan (MT1).....	B61165		
Outlet Fitting To Trans. (Lower).....			A63006	Connector "O" Ring.....			●A63091
Tube Nut.....			●A63011	Connector From Aux. Cooler.....			②A63017
Wire Retainer (Connectors) .....			●A63110	Inlet (Upper).....		≡A63004	
				Inlet Fitting To Trans. (Upper).....			A63006
				Outlet Fitting To Trans. (Lower).....			A63006
				Tube Nut.....			●A63011
				Wire Retainer (Connectors) .....			●A63110

② Two Required.  
③ Three Required.

④ Four Required.  
⑤ Five Required.

⑥ Six Required.  
⑦ Seven Required.

≡ Cut To Fit.  
● As Required.

See Pages 1 - 10 for Engine Oil Cooler Applications.

Product Section

Troubleshooting

EOC Applications

TOC Applications

Numerical Listing

Manufacturers' Part Numbers

End Fittings

Illustrations

## Transmission Oil Cooler Assemblies for Passenger Cars &amp; Light Trucks

Application	Assembly Number	Hoses & Tubes	Connectors & Fittings	Application	Assembly Number	Hoses & Tubes	Connectors & Fittings
<b>CHEVROLET - Continued</b>				<b>CHEVROLET - Continued</b>			
<b>C &amp; K SERIES PICKUP - Continued</b>				<b>CAMARO - Continued</b>			
<b>1993 - Continued</b>				<b>1997-1996 - Continued</b>			
<b>V-8 7.4 L ENG.</b>				<b>V-6 3.8 L ENG.; V-8 5.7 L ENG. - Continued</b>			
Aux. Cooler Inlet (Pass. Side); Exc. 3500HD .....	B61169			Outlet Tube To Trans. (Lower).....		≠A63004	●A63011
Aux. Cooler Outlet (Driver Side); 3500HD .....	B61109			Tube Nut.....			
Aux. Cooler Outlet (Pass. Side); Exc. 3500HD .....	B61159			<b>1995</b>			
Connector "O" Ring.....			●A63091	<b>V-6 3.4 L ENG.; V-6 3.8 L ENG.; V-8 5.7 L ENG.</b>			
Connector From Aux. Cooler.....			②A63017	Inlet Fitting To Trans. (Upper).....	A61221		A63006
Inlet (Upper).....		≠A63004		Inlet From Rad. (Upper).....		≠A63004	A63006
Inlet Fitting To Trans. (Upper).....			A63006	Inlet Tube To Trans. (Upper).....		≠A63004	A63006
Outlet Fitting To Trans. (Lower).....			A63006	Outlet Fitting To Trans. (Lower).....		≠A63000	A63006
Tube Nut.....			●A63011	Outlet Hose From Rad. (Lower).....		≠A63004	●A63011
Wire Retainer (Connectors).....			●A63110	Outlet Tube From Rad. (Lower).....		≠A63004	
				Outlet Tube To Trans. (Lower).....		≠A63004	
				Tube Nut.....			
<b>1992</b>				<b>1994-1993</b>			
<b>V-6 4.3 L ENG.; V-8 5.0 L ENG.; V-8 5.7 L ENG.; V-8 6.2 L DIESEL ENG.; V-8 6.5 L DIESEL ENG.; V-8 7.4 L ENG.</b>				<b>V-6 3.4 L ENG.; V-8 5.7 L ENG.</b>			
Inlet (Upper).....		≠A63004	A63006	Inlet Fitting To Trans. (Upper).....			A63006
Inlet Fitting To Trans. (Upper).....				Inlet From Rad. (Upper).....	A61221		
Outlet (Lower).....		≠A63004		Inlet Tube To Trans. (Upper).....		≠A63004	A63006
Outlet Fitting To Trans. (Lower).....			A63006	Outlet Fitting To Trans. (Lower).....			A63006
Tube Nut.....			④A63011	Outlet Hose From Rad. (Lower).....		≠A63000	
				Outlet Tube From Rad. (Lower).....		≠A63004	
				Outlet Tube To Trans. (Lower).....		≠A63004	●A63011
				Tube Nut.....			
<b>1991-1988</b>				<b>1992-1990</b>			
<b>V-6 4.3 L ENG.; V-8 5.0 L ENG.; V-8 5.7 L ENG.; V-8 6.2 L DIESEL ENG.; V-8 7.4 L ENG.</b>				<b>V-6 3.1 L ENG.; V-8 5.0 L ENG.; V-8 5.7 L ENG.</b>			
Inlet (Upper).....		≠A63004	A63006	Inlet (Upper).....		≠A63004	A63006
Inlet Fitting To Trans. (Upper).....				Inlet Fitting To Trans. (Upper).....		≠A63004	A63006
Outlet (Lower).....		≠A63004	A63006	Outlet (Lower).....		≠A63004	A63006
Outlet Fitting To Trans. (Lower).....			④A63011	Outlet Fitting To Trans. (Lower).....			A63006
Tube Nut.....				Tube Nut.....			④A63011
<b>1986-1985</b>				<b>1989-1987</b>			
<b>6-CYL. 4.8 L ENG.; V-6 4.3 L ENG.; V-8 5.0 L ENG.; V-8 5.7 L ENG.; V-8 6.2 L DIESEL ENG.; V-8 7.4 L ENG.</b>				<b>V-6 2.8 L ENG.; V-8 5.0 L ENG.; V-8 5.7 L ENG.</b>			
Inlet (Upper).....		≠A63004	A63006	Inlet (Upper).....		≠A63004	A63006
Inlet Fitting To Trans. (Upper).....				Inlet Fitting To Trans. (Upper).....		≠A63004	A63006
Outlet (Lower).....		≠A63004	A63006	Outlet (Lower).....		≠A63004	A63006
Outlet Fitting To Trans. (Lower).....			④A63011	Outlet Fitting To Trans. (Lower).....			④A63011
Tube Nut.....				Tube Nut.....			
<b>CAMARO</b>				<b>1986-1983</b>			
<b>2002-1998</b>				<b>4-CYL. 2.5 L ENG.; V-6 2.8 L ENG.; V-8 5.0 L ENG.</b>			
<b>V-6 3.8 L ENG.</b>				Inlet (Upper).....			
Inlet Fitting To Trans. (Upper).....			A63021			≠A63004	A63006
Inlet From Rad. (Upper).....	A61221			Inlet Fitting To Trans. (Upper).....		≠A63004	A63006
Inlet To Trans. (Lower).....	B61297			Outlet (Lower).....		≠A63004	A63006
Outlet Fitting To Trans. (Lower).....			A63021	Outlet Fitting To Trans. (Lower).....			A63006
Outlet From Rad. (Lower).....	B61296			Tube Nut.....			④A63011
Wire Retainer (Fittings).....			②A63098				
				<b>CAPRICE</b>			
<b>V-8 5.7 L ENG.</b>				<b>1996-1994</b>			
Inlet Fitting To Trans. (Upper).....			A63021	<b>V-8 4.3 L ENG.; V-8 5.7 L ENG.</b>			
Inlet From Rad. (Upper).....	A61221			Inlet Fitting To Trans. (Upper).....			A63007
Inlet To Trans. (Lower).....	B61295			Outlet Fitting To Trans. (Lower).....			A63007
Outlet Fitting To Trans. (Lower).....			A63021	Rad. Supply Tube (Upper To Lower); W/Aux. Cooler.....		≠A63005	
Outlet From Rad. (Lower).....	B61294			Rad. Supply Tube Nut (Upper); W/Aux. Cooler.....			A63013
Wire Retainer (Fittings).....			②A63098				
				<b>1993</b>			
<b>1997-1996</b>				<b>V-6 4.3 L ENG.</b>			
<b>V-6 3.8 L ENG.; V-8 5.7 L ENG.</b>				Inlet (Upper).....			
Inlet Fitting To Trans. (Upper).....			A63006			≠A63004	A63006
Inlet From Rad. (Upper).....	A61221			Inlet Fitting To Trans. (Upper).....			A63006
Inlet Tube To Trans. (Upper).....		≠A63004		Outlet (Lower).....		≠A63004	A63006
Outlet Fitting To Trans. (Lower).....			A63006	Outlet Fitting To Trans. (Lower).....			A63006
Outlet Hose From Rad. (Lower).....		≠A63000		Tube Nut To Trans. (Upper).....			A63011
Outlet Tube From Rad. (Lower).....		≠A63004		Tube Nuts From Rad.....			④A63011

② Two Required.  
③ Three Required.

④ Four Required.  
⑤ Five Required.

⑥ Six Required.  
⑦ Seven Required.

≠ Cut To Fit.  
● As Required.

See Pages 1 - 10 for Engine Oil Cooler Applications.

# Transmission Oil Cooler Assemblies for Passenger Cars & Light Trucks

Application	Assembly Number	Hoses & Tubes	Connectors & Fittings	Application	Assembly Number	Hoses & Tubes	Connectors & Fittings
<b>CHEVROLET - Continued</b>				<b>CHEVROLET - Continued</b>			
<b>CAPRICE - Continued</b>				<b>CAVALIER - Continued</b>			
<b>1993 - Continued</b>				<b>1994-1990 - Continued</b>			
<b>V-8 5.0 L ENG.; V-8 5.7 L ENG.</b>				<b>V-6 3.1 L ENG. - Continued</b>			
Inlet (Upper); W/O Aux. Cooler .....		✂-A63004		Inlet Fitting To Trans. (Upper); W/3-Speed Trans. ....	A61249		A63006
Inlet Fitting To Trans. (Upper) .....			A63006	Outlet (Lower) .....			A63006
Outlet (Lower) .....		✂-A63004		Outlet Fitting To Trans. (Lower); W/3-Speed Trans. ....			A63006
Outlet Fitting To Trans. (Lower) .....			A63006				
Tube Nut From Rad.; W/O Aux. Cooler .....			②A63011				
Tube Nut To Trans. (Upper); W/O Aux. Cooler .....			A63011				
<b>1992</b>				<b>1989-1986</b>			
<b>V-6 4.3 L ENG.; V-8 5.0 L ENG.; V-8 5.7 L ENG.</b>				<b>4-CYL. 2.0 L ENG.</b>			
Inlet (Upper) .....		✂-A63004		Inlet (Upper) .....	A61230		
Inlet Fitting To Trans. (Upper) .....			A63006	Inlet Fitting To Trans. (Upper); W/3-Speed Trans. ....			A63006
Outlet (Lower) .....		✂-A63004		Outlet (Lower) .....	A61150		A63006
Outlet Fitting To Trans. (Lower) .....			A63006	Outlet Fitting To Trans. (Lower); W/3-Speed Trans. ....			A63006
Tube Nut From Rad. ....			②A63011				
Tube Nut To Trans. (Upper) .....			A63011				
<b>1991</b>				<b>V-6 2.8 L ENG.</b>			
<b>V-8 5.0 L ENG.; V-8 5.7 L ENG.</b>				Inlet (Upper) .....			
Inlet (Upper) .....		✂-A63004		Inlet Fitting To Trans. (Upper); W/3-Speed Trans. ....	A61249		A63006
Inlet Fitting To Trans. (Upper) .....			A63006	Outlet (Lower) .....			A63006
Outlet (Lower) .....		✂-A63004		Outlet Fitting To Trans. (Lower); W/3-Speed Trans. ....			A63006
Outlet Fitting To Trans. (Lower) .....			A63006				
Tube Nut From Rad. ....			②A63011				
Tube Nut To Trans. (Upper) .....			A63011				
<b>1990-1986</b>				<b>1985</b>			
<b>V-6 4.3 L ENG.; V-8 5.0 L ENG.; V-8 5.7 L ENG.</b>				<b>V-6 2.8 L ENG.</b>			
Inlet (Upper) .....		✂-A63004		Inlet (Upper) .....	A61231		
Inlet Fitting To Trans. (Upper) .....			A63006	Inlet Fitting To Trans. (Upper); W/3-Speed Trans. ....			A63006
Outlet (Lower) .....		✂-A63004		Outlet (Lower) .....	A61249		A63006
Outlet Fitting To Trans. (Lower) .....			A63006	Outlet Fitting To Trans. (Lower); W/3-Speed Trans. ....			A63006
Tube Nut From Rad. ....			②A63011				
Tube Nut To Trans. (Upper) .....			A63011				
<b>1985</b>				<b>1985</b>			
<b>V-6 4.3 L ENG.; V-8 5.0 L ENG.; V-8 5.7 L DIESEL ENG.</b>				<b>V-6 2.8 L ENG.</b>			
Inlet (Upper) .....		✂-A63004		Inlet (Upper) .....	A61231		
Inlet Fitting To Trans. (Upper) .....			A63006	Inlet Fitting To Trans. (Upper); W/3-Speed Trans. ....			A63006
Outlet (Lower) .....		✂-A63004		Outlet (Lower) .....	A61249		A63006
Outlet Fitting To Trans. (Lower) .....			A63006	Outlet Fitting To Trans. (Lower); W/3-Speed Trans. ....			A63006
Tube Nut From Rad. ....			②A63011				
Tube Nut To Trans. (Upper) .....			A63011				
<b>CAVALIER</b>				<b>CELEBRITY</b>			
<b>2001-1995</b>				<b>1990</b>			
<b>4-CYL. 2.2 L ENG.</b>				<b>4-CYL. 2.5 L ENG.; V-6 3.1 L ENG.</b>			
Inlet (Upper); W/3-Speed Trans. ....	A61002			Inlet Fitting To Trans. (Upper) .....			A63006
Inlet Fitting To Trans. (Upper); W/3-Speed Trans. ....			A63006	Inlet Hose (Upper) .....		✂-A63000	
Outlet (Lower); W/3-Speed Trans. ....	A61003			Inlet Tube From Rad. (Upper) .....		✂-A63004	
Outlet Fitting To Trans. (Lower); W/3-Speed Trans. ....			A63006	Inlet Tube To Trans. (Upper) .....		✂-A63004	
				Outlet Fitting To Trans. (Lower) .....			A63006
				Outlet Hose (Lower) .....		✂-A63000	
				Outlet Tube From Rad. (Lower) .....		✂-A63004	
				Outlet Tube To Trans. (Lower) .....		✂-A63004	
				Tube Nut .....			④A63011
<b>1994-1990</b>				<b>1989-1985</b>			
<b>4-CYL. 2.2 L ENG.</b>				<b>4-CYL. 2.5 L ENG.; V-6 2.8 L ENG.</b>			
Inlet (Upper) .....	A61230			Inlet Fitting To Trans. (Upper) .....			A63006
Inlet Fitting To Trans. (Upper); W/3-Speed Trans. ....			A63006	Inlet Hose (Upper) .....		✂-A63000	
Outlet (Lower) .....	A61150			Inlet Tube From Rad. (Upper) .....		✂-A63004	
Outlet Fitting To Trans. (Lower); W/3-Speed Trans. ....			A63006	Inlet Tube To Trans. (Upper) .....		✂-A63004	
				Outlet Fitting To Trans. (Lower) .....			A63006
				Outlet Hose (Lower) .....		✂-A63000	
				Outlet Tube From Rad. (Lower) .....		✂-A63004	
				Outlet Tube To Trans. (Lower) .....		✂-A63004	
				Tube Nut .....			④A63011
<b>V-6 3.1 L ENG.</b>				<b>CORSICA</b>			
Inlet (Upper) .....	A61231			<b>1996-1994</b>			
				<b>4-CYL. 2.2 L ENG.</b>			
				Inlet (Upper) .....	B61232		A63006
				Inlet Fitting To Trans. (Upper) .....			A63006
				Outlet (Lower) .....	B61233		A63006
				Outlet Fitting To Trans. (Lower) .....			A63006
				<b>V-6 3.1 L ENG.</b>			
				Inlet (Upper) .....	B61119		

② Two Required.  
③ Three Required.

④ Four Required.  
⑤ Five Required.

⑥ Six Required.  
⑦ Seven Required.

✂ Cut To Fit.  
● As Required.

See Pages 1 - 10 for Engine Oil Cooler Applications.

Product Section

Troubleshooting

EOC Applications

TOC Applications

Numerical Listing

Manufacturers' Part Numbers

End Fittings

Illustrations

## Transmission Oil Cooler Assemblies for Passenger Cars &amp; Light Trucks

Application	Assembly Number	Hoses & Tubes	Connectors & Fittings	Application	Assembly Number	Hoses & Tubes	Connectors & Fittings
<b>CHEVROLET - Continued</b>				<b>CHEVROLET - Continued</b>			
<b>CORSICA - Continued</b>				<b>EXPRESS - Continued</b>			
<b>1996-1994 - Continued</b>				<b>2003 - Continued</b>			
<b>V-6 3.1 L ENG. - Continued</b>				<b>V-6 4.3 L ENG. - Continued</b>			
Inlet Fitting To Trans. (Upper).....			A63007	Outlet Fitting To Trans. Case (Lower); W/17-Bolt Trans. Pan (MT1).			A63027
Outlet (Lower).....	A61134		A63008	Quick Connect Tube Fitting (Lower); W/16-Bolt Trans. Pan (M30).			A63021
Outlet Fitting To Trans. (Lower).....				Quick Connect Tube Fitting (Upper); W/16-Bolt Trans. Pan (M30).....			A63021
<b>1993-1992</b>				Wire Retainer (Fittings).....			●A63098
<b>4-CYL. 2.2 L ENG.; V-6 3.1 L ENG.</b>				<b>V-8 4.8 L ENG.</b>			
Inlet (Upper).....	A61229		A63006	Connector From Aux. Cooler; W/16-Bolt Trans. Pan (M30).....			⊗A63017
Inlet Fitting To Trans. (Upper).....			A63006	Connector From Aux. Cooler; W/17-Bolt Trans. Pan (MT1).....			⊗A63006
Outlet (Lower).....	A61227		A63006	Inlet Fitting From Rad. (Upper); W/Aux. Cooler.....			A63027
Outlet Fitting To Trans. (Lower).....				Inlet Fitting To Trans. (Upper); W/Aux. Cooler.....			A63027
<b>1991-1990</b>				Outlet Fitting From Rad. (Lower); W/Aux. Cooler.....			A63027
<b>4-CYL. 2.2 L ENG.; V-6 3.1 L ENG.</b>				Outlet Fitting To Trans. (Lower); W/Aux. Cooler.....			A63027
Inlet (Upper).....	A61246		A63006	Quick Connect Tube Fitting (Lower); W/O Aux. Cooler.....			⊗A63021
Inlet Fitting To Trans. (Upper).....			A63006	Quick Connect Tube Fitting (Upper); W/O Aux. Cooler.....			⊗A63021
Outlet (Lower).....	A61247		A63006	Wire Retainer (Connectors & Fittings).....			●A63098
Outlet Fitting To Trans. (Lower).....				<b>V-8 5.3 L ENG.</b>			
<b>1989-1987</b>				<b>V-8 6.0 L ENG.</b>			
<b>4-CYL. 2.0 L ENG.; V-6 2.8 L ENG.</b>				<b>2002-2001</b>			
Inlet (Upper).....	A61246		A63006	<b>V-6 4.3 L ENG.</b>			
Inlet Fitting To Trans. (Upper).....			A63006	Aux. Cooler Inlet (Upper); W/17-Bolt Trans. Pan (MT1).....	A61314		
Outlet (Lower).....	A61247		A63006	Connector From Rad.; W/16-Bolt Trans. Pan (M30).....			⊗A63018
Outlet Fitting To Trans. (Lower).....				Connector From Rad.; W/17-Bolt Trans. Pan (MT1).....			⊗A63006
<b>CORVETTE</b>				<b>2002-2001</b>			
<b>2003-1997</b>				<b>V-6 4.3 L ENG.</b>			
<b>V-8 5.7 L ENG.</b>				<b>V-6 4.3 L ENG.</b>			
Inlet Fitting To Trans. (Upper).....			A63007	Aux. Cooler Inlet (Upper); W/17-Bolt Trans. Pan (MT1).....	A61314		
Inlet Tube To Trans. (Upper).....	≠A63005		A63007	Connector From Rad.; W/16-Bolt Trans. Pan (M30).....			⊗A63018
Outlet Fitting To Trans. (Upper).....				Connector From Rad.; W/17-Bolt Trans. Pan (MT1).....			⊗A63006
Outlet Tube To Trans. (Lower).....	≠A63005			Inlet Fitting To Trans. (Upper); W/16-Bolt Trans. Pan (M30).....			A63021
Tube Nut.....			⊕A63013	Inlet Fitting To Trans. (Upper); W/17-Bolt Trans. Pan (MT1).....			A63006
<b>1996-1984</b>				<b>2002-2001</b>			
<b>V-8 5.7 L ENG.</b>				<b>V-6 4.3 L ENG.</b>			
Inlet (Upper).....			≠A63004	Aux. Cooler Inlet (Upper); W/17-Bolt Trans. Pan (MT1).....	A61314		
Inlet Fitting To Trans. (Upper).....				Connector From Rad.; W/16-Bolt Trans. Pan (M30).....			⊗A63018
Outlet (Lower).....			≠A63004	Connector From Rad.; W/17-Bolt Trans. Pan (MT1).....			⊗A63006
Outlet Fitting To Trans. (Lower).....				Inlet Fitting To Trans. (Upper); W/16-Bolt Trans. Pan (M30).....			A63021
Tube Nut From Rad.....				Inlet Fitting To Trans. (Upper); W/17-Bolt Trans. Pan (MT1).....			A63006
<b>EL CAMINO</b>				<b>2002-2001</b>			
<b>1987-1986</b>				<b>V-6 4.3 L ENG.</b>			
<b>V-6 4.3 L ENG.; V-8 5.0 L ENG.</b>				<b>V-6 4.3 L ENG.</b>			
Inlet (Upper).....			≠A63004	Aux. Cooler Inlet (Upper); W/17-Bolt Trans. Pan (MT1).....	A61314		
Inlet Fitting To Trans. (Upper).....				Connector From Rad.; W/16-Bolt Trans. Pan (M30).....			⊗A63018
Outlet (Lower).....			≠A63004	Connector From Rad.; W/17-Bolt Trans. Pan (MT1).....			⊗A63006
Outlet Fitting To Trans. (Lower).....				Inlet Fitting To Trans. (Upper); W/16-Bolt Trans. Pan (M30).....			A63021
Tube Nut.....				Inlet Fitting To Trans. (Upper); W/17-Bolt Trans. Pan (MT1).....			A63006
<b>EXPRESS</b>				<b>2002-2001</b>			
<b>2003</b>				<b>V-6 4.3 L ENG.</b>			
<b>V-6 4.3 L ENG.</b>				<b>V-6 4.3 L ENG.</b>			
Connector From Rad.; W/16-Bolt Trans. Pan (M30).....			⊕A63021	Aux. Cooler Inlet (Upper); W/17-Bolt Trans. Pan (MT1).....	A61314		
Inlet Fitting To Trans. (Upper); W/17-Bolt Trans. Pan (MT1).....			A63006	Connector From Rad.; W/16-Bolt Trans. Pan (M30).....			⊗A63018
Inlet Fitting To Trans. Case (Upper); W/17-Bolt Trans. Pan (MT1).....			A63027	Connector From Rad.; W/17-Bolt Trans. Pan (MT1).....			⊗A63006
Outlet Fitting To Trans. (Lower); W/17-Bolt Trans. Pan (MT1).....			A63006	Inlet Fitting To Trans. (Upper); W/16-Bolt Trans. Pan (M30).....			A63021
				Inlet Fitting To Trans. (Upper); W/17-Bolt Trans. Pan (MT1).....			A63006
				Inlet Fitting To Trans. Case (Upper); W/17-Bolt Trans. Pan (MT1).....			A63027
				Outlet Fitting To Trans. (Lower); W/16-Bolt Trans. Pan (M30).....			A63021
				Outlet Fitting To Trans. (Lower); W/17-Bolt Trans. Pan (MT1).....			A63006
				Wire Retainer (Connectors & Fittings).....			●A63098
				<b>V-8 5.0 L ENG.</b>			
				Connector From Rad. ....			⊗A63018
				Inlet (Upper).....	B61311		
				Inlet Fitting To Trans. (Upper).....			A63021
				Outlet (Lower).....	B61259		
				Outlet Fitting To Trans. (Lower).....			A63021
				Wire Retainer (Connectors & Fittings).....			●A63098

⊗ Two Required.  
⊕ Three Required.

⊕ Four Required.  
⊖ Five Required.

⊖ Six Required.  
⊗ Seven Required.

≠ Cut To Fit.  
● As Required.

See Pages 1 - 10 for Engine Oil Cooler Applications.

# Transmission Oil Cooler Assemblies for Passenger Cars & Light Trucks

Application	Assembly Number	Hoses & Tubes	Connectors & Fittings	Application	Assembly Number	Hoses & Tubes	Connectors & Fittings
<b>CHEVROLET - Continued</b>				<b>CHEVROLET - Continued</b>			
<b>EXPRESS - Continued</b>				<b>EXPRESS - Continued</b>			
<b>2002-2001 - Continued</b>				<b>2000-1998 - Continued</b>			
<b>V-8 5.7 L ENG.</b>				<b>V-8 5.7 L ENG. - Continued</b>			
Aux. Cooler Inlet (Upper); W/17-Bolt Trans. Pan (MT1) .....	A61314			Inlet Fitting To Trans. (Upper); W/17-Bolt Trans. Pan (MT1) .....			A63006
Aux. Cooler Outlet (Driver Side); W/17-Bolt Trans. Pan (MT1) .....	B61261			Inlet Fitting To Trans. Case (Upper); W/17-Bolt Trans. Pan (MT1) .....			A63027
Connector From Rad.; W/16-Bolt Trans. Pan (M30) .....			②A63018	Inlet From Rad. (Upper); W/16-Bolt Trans. Pan (M30) .....	B61311		
Connector From Rad.; W/17-Bolt Trans. Pan (MT1) .....			②A63006	Inlet From Rad. (Upper); W/17-Bolt Trans. Pan (MT1) .....	B61260		
Inlet Fitting To Trans. (Upper); W/16-Bolt Trans. Pan (M30) .....			A63021	Outlet (Lower); W/16-Bolt Trans. Pan (M30) .....	B61259		
Inlet Fitting To Trans. (Upper); W/17-Bolt Trans. Pan (MT1) .....			A63027	Outlet Fitting To Trans. (Lower); W/16-Bolt Trans. Pan (M30) .....			A63021
Inlet From Rad. (Upper); W/16-Bolt Trans. Pan (M30) .....	B61311			Outlet Fitting To Trans. (Lower); W/17-Bolt Trans. Pan (MT1) .....			A63006
Inlet From Rad. (Upper); W/17-Bolt Trans. Pan (MT1) .....	B61260			Wire Retainer (Connectors & Fit- tings) .....			●A63098
Outlet (Lower); W/16-Bolt Trans. Pan (M30) .....	B61259			<b>V-8 6.5 L DIESEL ENG.; V-8 7.4 L ENG.</b>			
Outlet Fitting To Trans. (Lower) .....			A63021	Connector From Rad. ....			②A63006
Wire Retainer (Connectors & Fit- tings) .....			●A63098	Inlet Fitting To Trans. (Upper) .....			A63021
<b>V-8 6.5 L DIESEL ENG.; V-8 8.1 L ENG.</b>				Inlet Fitting To Trans. Case (Up- per) .....			A63027
Connector From Rad. ....			②A63006	Outlet Fitting To Trans. (Lower) .....			A63021
Inlet Fitting To Trans. (Upper) .....			A63021	Wire Retainer (Fittings) .....			●A63098
Inlet Fitting To Trans. Case (Up- per) .....			A63027				
Outlet Fitting To Trans. (Lower) .....			A63021	<b>1997</b>			
Wire Retainer (Fittings) .....			●A63098	<b>V-6 4.3 L ENG.</b>			
<b>2000-1998</b>				Aux. Cooler Inlet (Upper); W/17-Bolt Trans. Pan (MT1) .....	A61314		
<b>V-6 4.3 L ENG.</b>				Connector From Rad.; W/16-Bolt Trans. Pan (M30) .....			②A63018
Aux. Cooler Inlet (Upper); W/17-Bolt Trans. Pan (MT1) .....	A61314			Connector From Rad.; W/17-Bolt Trans. Pan (MT1) .....			②A63006
Connector From Rad.; W/16-Bolt Trans. Pan (M30) .....			②A63018	Inlet Fitting To Trans. (Upper); W/16-Bolt Trans. Pan (M30) .....			A63021
Connector From Rad.; W/17-Bolt Trans. Pan (MT1) .....			②A63006	Inlet Fitting To Trans. (Upper); W/17-Bolt Trans. Pan (MT1) .....			A63006
Inlet Fitting To Trans. (Upper); W/16-Bolt Trans. Pan (M30) .....			A63021	Inlet Fitting To Trans. Case (Up- per); W/17-Bolt Trans. Pan (MT1) .....			A63027
Inlet Fitting To Trans. (Upper); W/17-Bolt Trans. Pan (MT1) .....			A63006	Outlet Fitting To Trans. (Lower); W/16-Bolt Trans. Pan (M30) .....			A63021
Inlet Fitting To Trans. Case (Up- per); W/17-Bolt Trans. Pan (MT1) .....			A63027	Outlet Fitting To Trans. (Lower); W/17-Bolt Trans. Pan (MT1) .....			A63006
Outlet Fitting To Trans. (Lower); W/16-Bolt Trans. Pan (M30) .....			A63021	Wire Retainer (Connectors & Fit- tings) .....			●A63098
Outlet Fitting To Trans. (Lower); W/17-Bolt Trans. Pan (MT1) .....			A63006	<b>V-8 5.0 L ENG.</b>			
Wire Retainer (Connectors & Fit- tings) .....			●A63098	Connector From Rad. ....			②A63018
<b>V-8 5.0 L ENG.</b>				Inlet (Upper) .....	B61269		A63021
Connector From Rad. ....			②A63018	Inlet Fitting To Trans. (Upper) .....			A63021
Inlet (Upper) .....	B61311		A63021	Outlet (Lower) .....	B61268		A63021
Inlet Fitting To Trans. (Upper) .....				Outlet Fitting To Trans. (Lower) .....			A63021
Outlet (Lower) .....	B61259			Wire Retainer (Connectors & Fit- tings) .....			●A63098
Outlet Fitting To Trans. (Lower) .....			A63021	<b>V-8 5.7 L ENG.</b>			
Wire Retainer (Connectors & Fit- tings) .....			●A63098	Aux. Cooler Inlet (Upper); W/17-Bolt Trans. Pan (MT1) .....	A61314		
<b>V-8 5.7 L ENG.</b>				Aux. Cooler Outlet (Driver Side); W/17-Bolt Trans. Pan (MT1) .....	B61261		
Aux. Cooler Inlet (Upper); W/17-Bolt Trans. Pan (MT1) .....	A61314			Connector From Rad.; W/16-Bolt Trans. Pan (M30) .....			②A63018
Aux. Cooler Outlet (Driver Side); W/17-Bolt Trans. Pan (MT1) .....	B61261			Connector From Rad.; W/17-Bolt Trans. Pan (MT1) .....			②A63006
Connector From Rad.; W/16-Bolt Trans. Pan (M30) .....			②A63018	Inlet (Upper); W/16-Bolt Trans. Pan (M30) .....	B61269		
Connector From Rad.; W/17-Bolt Trans. Pan (MT1) .....			②A63006	Inlet Fitting To Trans. (Upper); W/16-Bolt Trans. Pan (M30) .....			A63021
Inlet Fitting To Trans. (Upper); W/16-Bolt Trans. Pan (M30) .....			A63021	Inlet Fitting To Trans. (Upper); W/17-Bolt Trans. Pan (MT1) .....			A63021

② Two Required.  
③ Three Required.

④ Four Required.  
⑤ Five Required.

⑥ Six Required.  
⑦ Seven Required.

✂ Cut To Fit.  
● As Required.

See Pages 1 - 10 for Engine Oil Cooler Applications.

## Transmission Oil Cooler Assemblies for Passenger Cars &amp; Light Trucks

Application	Assembly Number	Hoses & Tubes	Connectors & Fittings	Application	Assembly Number	Hoses & Tubes	Connectors & Fittings
<b>CHEVROLET - Continued</b>				<b>CHEVROLET - Continued</b>			
<b>EXPRESS - Continued</b>				<b>EXPRESS - Continued</b>			
<b>1997 - Continued</b>				<b>1996 - Continued</b>			
<b>V-8 5.7 L ENG. - Continued</b>				<b>V-8 7.4 L ENG. - Continued</b>			
Inlet Fitting To Trans. Case (Upper); W/17-Bolt Trans. Pan (MT1).....			A63027	Outlet Fitting To Trans. (Lower); W/O Aux. Cooler.....			A63006
Inlet From Rad. (Upper); W/17-Bolt Trans. Pan (MT1).....	B61260			Outlet Fitting To Trans. Case (Lower); W/O Aux. Cooler.....			A63007
Outlet (Lower).....	B61268			Wire Retainer (Fittings).....			●A63098
Outlet Fitting To Trans. (Lower); W/16-Bolt Trans. Pan (M30).....			A63021	<b>G SERIES VAN</b>			
Outlet Fitting To Trans. (Lower); W/17-Bolt Trans. Pan (MT1).....			A63006	<b>1998</b>			
Wire Retainer (Connectors & Fittings).....			●A63098	<b>V-6 4.3 L ENG.</b>			
<b>V-8 6.5 L DIESEL ENG.; V-8 7.4 L ENG.</b>				Aux. Cooler Inlet (Upper); W/17-Bolt Trans. Pan (MT1).....			
Connector From Rad. ....			②A63006		A61314		
Inlet Fitting To Trans. (Upper).....			A63021	Connector From Rad.; W/16-Bolt Trans. Pan (M30).....			②A63018
Inlet Fitting To Trans. Case (Upper).....			A63027	Connector From Rad.; W/17-Bolt Trans. Pan (MT1).....			②A63006
Outlet Fitting To Trans. (Lower).....			A63021	Inlet Fitting To Trans. (Upper); W/16-Bolt Trans. Pan (M30).....			A63021
Wire Retainer (Fittings).....			●A63098	Inlet Fitting To Trans. (Upper); W/17-Bolt Trans. Pan (MT1).....			A63006
<b>1996</b>				Inlet Fitting To Trans. Case (Upper); W/17-Bolt Trans. Pan (MT1).....			
<b>V-6 4.3 L ENG.; V-8 5.7 L ENG.</b>				Outlet Fitting To Trans. (Lower); W/16-Bolt Trans. Pan (M30).....			
Aux. Cooler Inlet (Upper); W/17-Bolt Trans. Pan (MT1).....	A61314			Outlet Fitting To Trans. (Lower); W/17-Bolt Trans. Pan (MT1).....			A63006
Connector From Rad.; W/16-Bolt Trans. Pan (M30).....			②A63018	Wire Retainer (Connectors & Fittings).....			●A63098
Connector From Rad.; W/17-Bolt Trans. Pan (MT1).....			②A63006	<b>V-8 5.0 L ENG.</b>			
Inlet Fitting To Trans. (Upper); W/16-Bolt Trans. Pan (M30).....			A63021	Connector From Rad. ....			
Inlet Fitting To Trans. (Upper); W/17-Bolt Trans. Pan (MT1).....			A63006	Inlet (Upper).....			
Inlet Fitting To Trans. Case (Upper).....			A63007	Inlet Fitting To Trans. (Upper).....			
Outlet Fitting To Trans. (Lower); W/16-Bolt Trans. Pan (M30).....			A63021	Outlet (Lower).....			
Outlet Fitting To Trans. (Lower); W/17-Bolt Trans. Pan (MT1).....			A63006	Outlet Fitting To Trans. (Lower).....			
Wire Retainer (Connectors & Fittings).....			●A63098	Wire Retainer (Connectors & Fittings).....			
<b>V-8 5.0 L ENG.</b>				Inlet Fitting To Trans. (Upper); W/16-Bolt Trans. Pan (M30).....			
Connector From Rad. ....			②A63018	Inlet Fitting To Trans. (Upper); W/17-Bolt Trans. Pan (MT1).....			
Inlet Fitting To Trans. (Upper).....			A63021	Inlet Fitting To Trans. Case (Upper); W/17-Bolt Trans. Pan (MT1).....			
Inlet Fitting To Trans. Case (Upper).....			A63007	Inlet Fitting To Trans. Case (Upper); W/17-Bolt Trans. Pan (MT1).....			
Outlet Fitting To Trans. (Lower).....			A63021	Inlet From Rad. (Upper); W/16-Bolt Trans. Pan (M30).....			
Wire Retainer (Connectors & Fittings).....			●A63098	Inlet From Rad. (Upper); W/17-Bolt Trans. Pan (MT1).....			
<b>V-8 6.5 L DIESEL ENG.</b>				Outlet (Lower); W/16-Bolt Trans. Pan (M30).....			
Connector From Rad.; W/O Quick Connect Fitting.....			②A63006	Outlet Fitting To Trans. (Lower); W/16-Bolt Trans. Pan (M30).....			
Connector From Rad.; W/Quick Connect Fitting.....			②A63018	Outlet Fitting To Trans. (Lower); W/17-Bolt Trans. Pan (MT1).....			
Inlet Fitting To Trans. (Upper).....			A63006	Wire Retainer (Fittings).....			
Outlet Fitting To Trans. (Lower).....			A63006	<b>V-8 7.4 L ENG.</b>			
Wire Retainer (Fittings).....			●A63098	Connector From Rad.; W/Aux. Cooler.....			
<b>V-8 7.4 L ENG.</b>				Connector From Rad.; W/O Aux. Cooler.....			
Connector From Rad.; W/Aux. Cooler.....			②A63018	Inlet Fitting To Trans. (Upper); W/Aux. Cooler.....			
Connector From Rad.; W/O Aux. Cooler.....			②A63006	Inlet Fitting To Trans. (Upper); W/O Aux. Cooler.....			
Inlet Fitting To Trans. (Upper); W/Aux. Cooler.....			A63018	Inlet Fitting To Trans. Case (Upper); W/O Aux. Cooler.....			
Inlet Fitting To Trans. (Upper); W/O Aux. Cooler.....			A63006	Outlet Fitting To Trans. (Lower); W/Aux. Cooler.....			
Inlet Fitting To Trans. Case (Upper); W/O Aux. Cooler.....			A63007	Outlet Fitting To Trans. (Lower); W/Aux. Cooler.....			
Outlet Fitting To Trans. (Lower); W/Aux. Cooler.....			A63018				

② Two Required.  
③ Three Required.

④ Four Required.  
⑤ Five Required.

⑥ Six Required.  
⑦ Seven Required.

≠ Cut To Fit.  
● As Required.

See Pages 1 - 10 for Engine Oil Cooler Applications.

# Transmission Oil Cooler Assemblies for Passenger Cars & Light Trucks

Application	Assembly Number	Hoses & Tubes	Connectors & Fittings	Application	Assembly Number	Hoses & Tubes	Connectors & Fittings
<b>CHEVROLET - Continued</b>				<b>CHEVROLET - Continued</b>			
<b>G SERIES VAN - Continued</b>				<b>G SERIES VAN - Continued</b>			
<b>1998 - Continued</b>				<b>1996</b>			
<b>V-8 6.5 L DIESEL ENG.; V-8 7.4 L ENG. - Continued</b>				<b>V-6 4.3 L ENG.; V-8 5.7 L ENG.; V-8 6.5 L DIESEL ENG.</b>			
Inlet Fitting To Trans. Case (Upper).....			A63027	Aux. Cooler Inlet Hose (Lower).....	A61220		
Outlet Fitting To Trans. (Lower).....			A63021	Inlet (Upper).....		≠A63004	
Wire Retainer (Fittings).....			●A63098	Inlet Fitting To Trans. (Upper).....			A63006
				Outlet (Lower); W/O Aux. Cooler....		≠A63004	
				Outlet Fitting To Trans. (Lower).....			A63006
				Tube Nut.....			●A63011
<b>1997</b>				<b>V-8 7.4 L ENG.</b>			
<b>V-6 4.3 L ENG.</b>				Aux. Cooler Inlet Hose (Lower).....	A61213		
Aux. Cooler Inlet (Upper);				Inlet (Upper).....		≠A63004	
W/17-Bolt Trans. Pan (MT1).....	A61314			Inlet Fitting To Trans. (Upper).....			A63006
Connector From Rad.; W/16-Bolt				Outlet (Lower); W/Aux. Cooler.....	B61214		
Trans. Pan (M30).....			②A63018	Outlet (Lower); W/O Aux. Cooler....		≠A63004	
Connector From Rad.; W/17-Bolt				Outlet Fitting To Trans. (Lower).....			A63006
Trans. Pan (MT1).....			②A63006	Tube Nut.....			●A63011
Inlet Fitting To Trans. (Upper);							
W/16-Bolt Trans. Pan (M30).....			A63021				
Inlet Fitting To Trans. (Upper);							
W/17-Bolt Trans. Pan (MT1).....			A63006				
Inlet Fitting To Trans. Case (Upper);							
W/17-Bolt Trans. Pan			A63027				
(MT1).....							
Outlet Fitting To Trans. (Lower);							
W/16-Bolt Trans. Pan (M30).....			A63021				
Outlet Fitting To Trans. (Lower);							
W/17-Bolt Trans. Pan (MT1).....			A63006				
Wire Retainer (Connectors & Fittings).....			●A63098				
<b>V-8 5.0 L ENG.</b>							
Connector From Rad. ....			②A63018				
Inlet (Upper).....	B61269						
Inlet Fitting To Trans. (Upper).....			A63021				
Outlet (Lower).....	B61268						
Outlet Fitting To Trans. (Lower).....			A63021				
Wire Retainer (Connectors & Fittings).....			●A63098				
<b>V-8 5.7 L ENG.</b>							
Aux. Cooler Inlet (Upper);							
W/17-Bolt Trans. Pan (MT1).....	A61314						
Aux. Cooler Outlet (Driver Side);							
W/17-Bolt Trans. Pan (MT1).....	B61261						
Connector From Rad.; W/16-Bolt							
Trans. Pan (M30).....			②A63018				
Connector From Rad.; W/17-Bolt							
Trans. Pan (MT1).....			②A63006				
Inlet (Upper); W/16-Bolt Trans. Pan							
(M30).....	B61269						
Inlet Fitting To Trans. (Upper);							
W/16-Bolt Trans. Pan (M30).....			A63021				
Inlet Fitting To Trans. (Upper);							
W/17-Bolt Trans. Pan (MT1).....			A63006				
Inlet Fitting To Trans. Case (Upper);							
W/17-Bolt Trans. Pan			A63027				
(MT1).....							
Inlet From Rad. (Upper); W/17-Bolt							
Trans. Pan (MT1).....	B61260						
Outlet (Lower).....	B61268						
Outlet Fitting To Trans. (Lower);							
W/16-Bolt Trans. Pan (M30).....			A63021				
Outlet Fitting To Trans. (Lower);							
W/17-Bolt Trans. Pan (MT1).....			A63006				
Wire Retainer (Connectors & Fittings).....			●A63098				
<b>V-8 6.5 L DIESEL ENG.; V-8 7.4 L ENG.</b>							
Connector From Rad. ....			②A63006				
Inlet Fitting To Trans. (Upper).....			A63021				
Inlet Fitting To Trans. Case (Upper)							
.....			A63027				
Outlet Fitting To Trans. (Lower).....							
Wire Retainer (Fittings).....			●A63098				

② Two Required.  
③ Three Required.

④ Four Required.  
⑤ Five Required.

⑥ Six Required.  
⑦ Seven Required.

≠ Cut To Fit.  
● As Required.

See Pages 1 - 10 for Engine Oil Cooler Applications.

Product Section

Troubleshooting

EOC Applications

TOC Applications

Numerical Listing

Manufacturers' Part Numbers

End Fittings

Illustrations

## Transmission Oil Cooler Assemblies for Passenger Cars &amp; Light Trucks

Application	Assembly Number	Hoses & Tubes	Connectors & Fittings	Application	Assembly Number	Hoses & Tubes	Connectors & Fittings
<b>CHEVROLET - Continued</b>				<b>CHEVROLET - Continued</b>			
<b>IMPALA - Continued</b>				<b>LUMINA - Continued</b>			
<b>2003-2000 - Continued</b>				<b>1997-1995</b>			
<b>V-6 3.4 L ENG.; V-6 3.8 L ENG. - Continued</b>				<b>V-6 3.1 L ENG.; V-6 3.4 L ENG.</b>			
Inlet Fitting To Trans. (Upper).....			A63021	Aux. Cooler Inlet (Upper).....	B61237		
Outlet Fitting To Trans. (Lower).....			A63064	Aux. Cooler Outlet (Lower).....	A61236		
Wire Retainer (Connectors & Fittings).....			●A63098	Inlet Fitting To Trans. (Upper).....			A63007
				Inlet To Trans. (Upper).....	A61031		
				Outlet Fitting To Trans. (Lower).....			A63008
				Outlet To Trans. (Lower).....	A61030		
<b>1985</b>				<b>1994</b>			
<b>V-6 4.3 L ENG.; V-8 5.0 L ENG.; V-8 5.7 L ENG.</b>				<b>V-6 3.1 L ENG.; V-6 3.4 L ENG.</b>			
Inlet (Upper).....		≠A63004		Inlet Fitting To Trans. (Upper).....			A63007
Inlet Fitting To Trans. (Upper).....			A63006	Inlet To Trans. (Upper).....	A61031		
Outlet (Lower).....		≠A63004		Outlet Fitting To Trans. (Lower).....			A63008
Outlet Fitting To Trans. (Lower).....			A63006	Outlet To Trans. (Lower).....	A61030		
Tube Nut From Rad.....			ⓐA63011				
Tube Nut To Trans. (Upper).....			A63011				
<b>IMPALA SS</b>				<b>1993</b>			
<b>1996-1994</b>				<b>V-6 3.1 L ENG.</b>			
<b>V-8 5.7 L ENG.</b>				Inlet Fitting To Trans. (Upper);			
Inlet Fitting To Trans. (Upper).....			A63007	W/3-Speed Trans.....			A63006
Outlet Fitting To Trans. (Lower).....			A63007	Inlet Fitting To Trans. (Upper);			
Rad. Supply Tube (Upper To Lower); W/Aux. Cooler.....		≠A63005		W/4-Speed Trans.....			A63007
Rad. Supply Tube Nut (Upper); W/Aux. Cooler.....			A63013	Inlet Hose To Trans. (Upper);			
				W/3-Speed Trans.....		≠A63000	
				Inlet Tube From Rad. (Upper);			
				W/4-Speed Trans.....		≠A63005	
				Inlet Tube To Trans. (Upper);			
				W/3-Speed Trans.....		≠A63004	
				Inlet Tube To Trans. (Upper);			
				W/4-Speed Trans.....	A61031		
				Outlet Fitting To Trans. (Lower);			A63006
				W/3-Speed Trans.....			
				Outlet Fitting To Trans. (Lower);			A63008
				W/4-Speed Trans.....			
				Outlet Hose To Trans. (Lower);			
				W/3-Speed Trans.....		≠A63000	
				Outlet To Trans. (Lower);			
				W/4-Speed Trans.....	A61030		
				Outlet Tube From Rad. (Lower);			
				W/4-Speed Trans.....		≠A63005	
				Outlet Tube To Trans. (Lower);			
				W/3-Speed Trans.....		≠A63004	
				Tube Nut; W/3-Speed Trans.....			ⓐA63011
				Tube Nut; W/4-Speed Trans.....			ⓐA63013
				<b>V-6 3.4 L ENG.</b>			
				Inlet Fitting To Trans. (Upper);			
				W/4-Speed Trans.....			A63007
				Inlet From Rad. (Upper);			
				W/4-Speed Trans.....		≠A63005	
				Inlet To Trans. (Upper); W/4-Speed			
				Trans. ....	A61031		
				Outlet Fitting To Trans. (Lower);			
				W/4-Speed Trans.....			A63008
				Outlet From Rad. (Lower);			
				W/4-Speed Trans.....		≠A63005	
				Outlet To Trans. (Lower);			
				W/4-Speed Trans.....	A61030		
				Tube Nut; W/4-Speed Trans.....			ⓐA63013
				<b>1992-1991</b>			
				<b>4-CYL. 2.5 L ENG.</b>			
				Inlet Fitting To Trans. (Upper).....			A63006
				Inlet Hose To Trans. (Upper).....		≠A63000	
				Inlet Tube To Trans. (Upper).....		≠A63004	
				Outlet Fitting To Trans. (Lower).....			A63006
				Outlet Hose To Trans. (Lower).....		≠A63000	
				Outlet Tube To Trans. (Lower).....		≠A63004	
				Tube Nut.....			ⓐA63011

ⓐ Two Required.  
 ⓑ Three Required.

Ⓒ Four Required.  
 Ⓓ Five Required.

Ⓔ Six Required.  
 Ⓕ Seven Required.

≠ Cut To Fit.  
 ● As Required.

See Pages 1 - 10 for Engine Oil Cooler Applications.



# Transmission Oil Cooler Assemblies for Passenger Cars & Light Trucks

Application	Assembly Number	Hoses & Tubes	Connectors & Fittings	Application	Assembly Number	Hoses & Tubes	Connectors & Fittings
<b>CHEVROLET - Continued</b>				<b>CHEVROLET - Continued</b>			
<b>LUMINA - Continued</b>				<b>LUMINA APV</b>			
<b>1992-1991 - Continued</b>				<b>1996</b>			
<b>V-6 3.1 L ENG.</b>				<b>V-6 3.4 L ENG.</b>			
Inlet Fitting To Trans. (Upper); W/3-Speed Trans.....			A63006	Inlet Fitting To Trans. (Upper).....			A63007
Inlet Fitting To Trans. (Upper); W/4-Speed Trans.....			A63007	Inlet From Rad. (Upper).....	B61053		A63008
Inlet Hose To Trans. (Upper); W/3-Speed Trans.....		✂-A63000		Outlet Fitting To Trans. (Lower).....			
Inlet To Trans. (Upper); W/4-Speed Trans.....	A61031						
Inlet Tube From Rad. (Upper); W/4-Speed Trans.....		✂-A63005				✂-A63004	A63006
Inlet Tube To Trans. (Upper); W/3-Speed Trans.....		✂-A63004		Inlet To Trans. (Upper).....	A61052		A63006
Outlet Fitting To Trans. (Lower); W/3-Speed Trans.....			A63006	Outlet Fitting To Trans. (Lower).....		✂-A63004	A63006
Outlet Fitting To Trans. (Lower); W/4-Speed Trans.....			A63008	Outlet From Rad. (Lower).....		✂-A63004	
Outlet Hose To Trans. (Lower); W/3-Speed Trans.....		✂-A63000		Outlet To Trans. (Lower).....	A61052		
Outlet To Trans. (Lower); W/4-Speed Trans.....	A61030			Rad. Supply Tube (Upper To Low- er).....		✂-A63004	●A63011
Outlet Tube From Rad. (Lower); W/4-Speed Trans.....		✂-A63005		Tube Nut.....			
Outlet Tube To Trans. (Lower); W/3-Speed Trans.....		✂-A63004					
Tube Nut; W/3-Speed Trans.....			④A63011	<b>V-6 3.8 L ENG.</b>			A63007
Tube Nut; W/4-Speed Trans.....			②A63013	Inlet Fitting To Trans. (Upper).....			A63007
				Inlet From Rad. (Lower); W/Aux. Cooler.....	B61054		
<b>V-6 3.4 L ENG.</b>				Inlet From Rad. (Upper); W/O Aux. Cooler.....	B61053		A63008
Inlet Fitting To Trans. (Upper); W/4-Speed Trans.....			A63007	Outlet Fitting To Trans. (Lower).....			
Inlet To Trans. (Upper); W/4-Speed Trans.....	A61031			Outlet From Rad. (Lower); W/Aux. Cooler.....		✂-A63005	
Inlet Tube From Rad. (Upper); W/4-Speed Trans.....		✂-A63005		Outlet To Trans. (Upper); W/Aux. Cooler.....		✂-A63001	
Outlet Fitting To Trans. (Lower); W/4-Speed Trans.....			A63008				
Outlet To Trans. (Lower); W/4-Speed Trans.....	A61030			<b>1991-1990</b>			
Outlet Tube From Rad. (Lower); W/4-Speed Trans.....		✂-A63005		<b>V-6 3.1 L ENG.</b>			A63006
Tube Nut; W/4-Speed Trans.....	②B61013			Inlet Fitting To Trans. (Upper).....		✂-A63004	A63006
				Inlet From Rad. (Upper).....	A61052		A63006
				Inlet To Trans. (Upper).....		✂-A63004	
				Outlet Fitting To Trans. (Lower).....	A61052		A63006
				Outlet From Rad. (Lower).....		✂-A63004	
				Outlet To Trans. (Lower).....		✂-A63004	
				Rad. Supply Tube (Upper To Low- er).....		✂-A63004	●A63011
				Tube Nut.....			
				<b>MONTE CARLO</b>			
				<b>2003-2000</b>			
				<b>V-6 3.4 L ENG.; V-6 3.8 L ENG.</b>			
			A63006	Connector From Rad. ....			②A63065
		✂-A63000		Inlet Fitting To Trans. (Upper).....			A63021
		✂-A63004		Outlet Fitting To Trans. (Lower).....			A63064
		✂-A63000	A63006	Wire Retainer (Connectors & Fit- tings).....			●A63098
		✂-A63004					
			④A63011	<b>1999-1998</b>			
				<b>V-6 3.1 L ENG.; V-6 3.8 L ENG.</b>			
			A63006	Aux. Cooler Inlet (Upper).....	B61237		
		✂-A63000		Aux. Cooler Outlet (Lower).....	A61236		
		✂-A63004		Connector From Rad.; W/Aux. Cooler.....			②A63018
		✂-A63004		Inlet (Upper); W/O Aux. Cooler.....	B61239		A63007
		✂-A63004		Inlet Fitting To Trans. (Upper).....			
			A63006	Inlet To Trans. (Upper); W/Aux. Cooler.....	A61031		A63008
		✂-A63000		Outlet (Lower); W/O Aux. Cooler....	B61238		
		✂-A63004		Outlet Fitting To Trans. (Lower).....			
		✂-A63004		Outlet To Trans. (Lower); W/Aux. Cooler.....	A61030		
		✂-A63004	④A63011	Wire Retainer (Connectors & Fit- tings).....			●A63098

② Two Required.  
③ Three Required.

④ Four Required.  
⑤ Five Required.

⑥ Six Required.  
⑦ Seven Required.

✂ Cut To Fit.  
● As Required.

See Pages 1 - 10 for Engine Oil Cooler Applications.

## Transmission Oil Cooler Assemblies for Passenger Cars &amp; Light Trucks

Application	Assembly Number	Hoses & Tubes	Connectors & Fittings	Application	Assembly Number	Hoses & Tubes	Connectors & Fittings
<b>CHEVROLET - Continued</b>				<b>CHEVROLET - Continued</b>			
<b>MONTE CARLO - Continued</b>				<b>S SERIES PICKUP - Continued</b>			
<b>1997-1995</b>				<b>2003 - Continued</b>			
<b>V-6 3.1 L ENG.; V-6 3.4 L ENG.</b>				<b>4-CYL. 2.2 L ENG. - Continued</b>			
Aux. Cooler Inlet (Upper).....	B61237			Outlet Fitting To Trans. (Upper).....			A63021
Aux. Cooler Outlet (Lower).....	A61236			Wire Retainer (Connectors & Fittings).....			●A63098
Inlet Fitting To Trans. (Upper).....			A63007	<b>V-6 4.3 L ENG.</b>			
Inlet To Trans. (Upper).....	A61031			Connector From Rad.; Mar. 9 & Older.....			⊕A63065
Outlet Fitting To Trans. (Lower).....			A63008	Inlet Fitting To Trans. (Lower).....			A63021
Outlet To Trans. (Lower).....	A61030			Outlet Fitting To Trans. (Upper).....			A63021
<b>1988-1985</b>				<b>Wire Retainer (Connectors &amp; Fittings).....</b>			
<b>V-6 4.3 L ENG.; V-8 5.0 L ENG.</b>				●A63098			
Inlet Fitting To Trans. (Upper).....			A63006	<b>2002</b>			
Inlet Tube (Upper).....	⊗A63004			<b>4-CYL. 2.2 L ENG.</b>			
Outlet Fitting To Trans. (Lower).....			A63006	Connector From Rad. ....			⊕A63018
Outlet Tube (Lower).....	⊗A63004			Inlet Fitting To Trans. (Lower).....			A63021
Tube Nut From Rad.....			⊕A63011	Outlet Fitting To Trans. (Upper).....			A63021
Tube Nut To Trans. (Upper).....			A63011	Wire Retainer (Connectors & Fittings).....			●A63098
<b>1984-1982</b>				<b>2001-1998</b>			
<b>V-6 3.8 L ENG.; V-8 5.0 L ENG.</b>				<b>4-CYL. 2.2 L ENG.</b>			
Inlet Fitting To Trans. (Upper).....			A63006	Connector From Rad. ....			⊕A63018
Inlet Tube (Upper).....	⊗A63004			Inlet Fitting To Trans. (Lower).....			A63021
Outlet Fitting To Trans. (Lower).....			A63006	Outlet Fitting To Trans. (Upper).....			A63021
Outlet Tube (Lower).....	⊗A63004			Wire Retainer (Connectors & Fittings).....			●A63098
Tube Nut From Rad.....			⊕A63011	<b>V-6 4.3 L ENG.</b>			
Tube Nut To Trans. (Upper).....			A63011	Connector From Rad. ....			⊕A63065
<b>R &amp; V SERIES PICKUP</b>				Inlet Fitting To Trans. (Lower).....			
<b>1991-1989</b>				A63021			
<b>V-8 5.7 L ENG.; V-8 6.2 L DIESEL ENG.; V-8 7.4 L ENG.</b>				A63021			
Inlet (Upper).....	⊗A63004		A63006	Wire Retainer (Connectors & Fittings).....			●A63098
Inlet Fitting To Trans. (Upper).....				<b>2001-1998</b>			
Outlet (Lower).....	⊗A63004		A63006	<b>4-CYL. 2.2 L ENG.</b>			
Outlet Fitting To Trans. (Lower).....			⊕A63011	Connector From Rad. ....			⊕A63018
Tube Nut.....				Inlet Fitting To Trans. (Lower).....			A63021
<b>1988</b>				A63021			
<b>6-CYL. 4.8 L ENG.; V-8 5.7 L ENG.; V-8 6.2 L DIESEL ENG.;</b>				●A63098			
<b>V-8 7.4 L ENG.</b>				<b>V-6 4.3 L ENG.</b>			
Inlet (Upper).....	⊗A63004		A63006	Connector From Rad. ....	B61042		⊕A63018
Inlet Fitting To Trans. (Upper).....				Inlet (Lower).....			A63021
Outlet (Lower).....	⊗A63004		A63006	Inlet Fitting To Trans. (Lower).....			A63021
Outlet Fitting To Trans. (Lower).....			⊕A63011	Outlet (Upper).....	B61043		A63021
Tube Nut.....				Outlet Fitting To Trans. (Upper).....			A63021
<b>1987</b>				Wire Retainer (Connectors & Fittings).....			
<b>6-CYL. 4.8 L ENG.; V-6 4.3 L ENG.; V-8 5.7 L ENG.; V-8 6.2 L DIESEL ENG.; V-8 7.4 L ENG.</b>				●A63098			
Inlet (Upper).....	⊗A63004		A63006	<b>1997-1996</b>			
Inlet Fitting To Trans. (Upper).....				<b>4-CYL. 2.2 L ENG.</b>			
Outlet (Lower).....	⊗A63004		A63006	Inlet (Lower).....		⊗A63004	A63006
Outlet Fitting To Trans. (Lower).....			⊕A63011	Inlet Fitting To Trans. (Lower).....		⊗A63004	A63006
Tube Nut.....				Outlet (Upper).....			A63006
<b>S SERIES PICKUP</b>				Outlet Fitting To Trans. (Upper).....			
<b>2004</b>				⊕A63011			
<b>V-6 4.3 L ENG.</b>				<b>V-6 4.3 L ENG.</b>			
Inlet Fitting To Trans. (Lower).....			A63021	Connector From Rad. ....			⊕A63018
Outlet Fitting To Trans. (Upper).....			A63021	Inlet (Lower).....	B61042		A63021
Wire Retainer (Connectors & Fittings).....			●A63098	Inlet Fitting To Trans. (Lower).....			A63021
<b>2003</b>				Outlet (Upper).....			
<b>4-CYL. 2.2 L ENG.</b>				B61043			
Connector From Rad. ....			⊕A63018	Outlet Fitting To Trans. (Upper).....			A63021
Inlet Fitting To Trans. (Lower).....			A63021	Wire Retainer (Connectors & Fittings).....			●A63098
<b>1995-1994</b>				<b>1997-1996</b>			
<b>4-CYL. 2.2 L ENG.</b>				<b>4-CYL. 2.2 L ENG.</b>			
Inlet (Lower).....		⊗A63004	A63006	Inlet (Lower).....		⊗A63004	A63006
Inlet Fitting To Trans. (Lower).....		⊗A63004	A63006	Outlet (Upper).....		⊗A63004	A63006
Outlet (Upper).....			⊕A63011	Outlet Fitting To Trans. (Upper).....			A63006
Outlet Fitting To Trans. (Upper).....				Tube Nut.....			⊕A63011
Tube Nut.....				<b>V-6 4.3 L ENG.</b>			
<b>2003</b>				⊕A63018			
<b>4-CYL. 2.2 L ENG.</b>				A63021			
Connector From Rad. ....			⊕A63018	Connector From Rad. ....			⊕A63006
Inlet Fitting To Trans. (Lower).....			A63021	Inlet (Lower).....	⊗A63004		

⊕ Two Required.  
⊗ Three Required.

⊕ Four Required.  
⊗ Five Required.

⊕ Six Required.  
⊗ Seven Required.

⊗ Cut To Fit.  
● As Required.

See Pages 1 - 10 for Engine Oil Cooler Applications.

## Transmission Oil Cooler Assemblies for Passenger Cars & Light Trucks

Application	Assembly Number	Hoses & Tubes	Connectors & Fittings	Application	Assembly Number	Hoses & Tubes	Connectors & Fittings
<b>CHEVROLET - Continued</b>				<b>CHEVROLET - Continued</b>			
<b>S SERIES PICKUP - Continued</b>				<b>SILVERADO SERIES PICKUP - Continued</b>			
<b>1995-1994 - Continued</b>				<b>2003 - Continued</b>			
<b>V-6 4.3 L ENG. - Continued</b>				<b>V-8 8.1 L ENG. - Continued</b>			
Inlet Fitting To Trans. (Lower).....			A63006	Wire Retainer (Connectors & Fittings).....			●A63098
Outlet (Upper).....		✂A63004					
Outlet Fitting To Trans. (Upper).....			A63006				
Tube Nut.....			④A63011				
<b>1993-1988</b>				<b>2002</b>			
<b>4-CYL. 2.5 L ENG.; V-6 2.8 L ENG.; V-6 4.3 L ENG.</b>				<b>V-6 4.3 L ENG.; V-8 4.8 L ENG.; V-8 5.3 L ENG.</b>			
Inlet (Lower).....		✂A63004		Aux. Cooler Inlet (Pass. Side).....	B61264		
Inlet Fitting To Trans. (Lower).....			A63006	Aux. Cooler Outlet (Driver Side).....	B61266		
Outlet (Upper).....		✂A63004		Connector From Rad.; W/Aux. Cooler.....			●A63019
Outlet Fitting To Trans. (Upper).....			A63006	Connector From Rad.; W/O Aux. Cooler.....			●A63018
Tube Nut.....			④A63011	Inlet (Upper); W/O Aux. Cooler.....	B61267		A63021
<b>1987-1986</b>				<b>V-8 6.0 L ENG.</b>			
<b>4-CYL. 2.5 L ENG.; V-6 2.8 L ENG.</b>				Aux. Cooler Inlet (Driver Side); W/17-Bolt Trans. Pan (MT1).....			
Inlet (Lower).....		✂A63004		Aux. Cooler Inlet (Pass. Side); W/16-Bolt Trans. Pan (M30).....	B61264		
Inlet Fitting To Trans. (Lower).....			A63006	Aux. Cooler Outlet (Driver Side); W/16-Bolt Trans. Pan (M30).....	B61266		
Outlet (Upper).....		✂A63004		Aux. Cooler Outlet (Pass. Side); W/17-Bolt Trans. Pan (MT1).....	B61313		
Outlet Fitting To Trans. (Upper).....			A63006	Connector From Aux. Cooler.....			②A63019
Tube Nut.....			④A63011	Connector From Rad. ....			②A63018
<b>SILVERADO SERIES PICKUP</b>				<b>V-8 6.6 L DIESEL ENG.</b>			
<b>2003</b>				Connector From Aux. Cooler.....			
<b>V-6 4.3 L ENG.; V-8 4.8 L ENG.; V-8 5.3 L ENG.</b>				Connector From Rad. ....			
Aux. Cooler Inlet (Pass. Side).....	B61264			Inlet (Upper); W/16-Bolt Trans. Pan (M30); W/O Aux. Cooler.....	B61267		
Aux. Cooler Outlet (Driver Side).....	B61266			Inlet Fitting To Trans. Case (Lower); W/17-Bolt Trans. Pan (MT1).			A63027
Connector From Rad.; W/Aux. Cooler.....			●A63019	Outlet (Lower); W/16-Bolt Trans. Pan (M30).....	B61262		
Connector From Rad.; W/O Aux. Cooler.....			●A63018	Outlet (Lower); W/17-Bolt Trans. Pan (MT1).....	B61312		
Connector From Rad.; W/O Aux. Cooler.....				Outlet Fitting To Trans. (Lower); W/16-Bolt Trans. Pan (M30).....			A63006
Inlet (Upper); W/O Aux. Cooler.....	B61267			Quick Connect Tube Fitting (Lower); W/17-Bolt Trans. Pan (MT1).....			A63021
Inlet Fitting To Trans. (Upper).....			A63021	Quick Connect Tube Fitting (Upper).....			A63021
Outlet (Lower).....	B61262			Wire Retainer (Connectors & Fittings).....			●A63098
Outlet Fitting To Trans. (Lower).....			A63006				
Wire Retainer (Connectors & Fittings).....			●A63098	<b>V-8 8.1 L ENG.</b>			
<b>V-8 6.0 L ENG.</b>				Connector From Aux. Cooler.....			
Aux. Cooler Inlet (Driver Side); W/17-Bolt Trans. Pan (MT1).....	B61263			Connector From Rad. ....			②A63068
Aux. Cooler Inlet (Pass. Side); W/16-Bolt Trans. Pan (M30).....	B61264			Wire Retainer (Aux. Cooler).....			②A63067
Aux. Cooler Outlet (Driver Side); W/16-Bolt Trans. Pan (M30).....	B61266						②A63099
Aux. Cooler Outlet (Pass. Side); W/17-Bolt Trans. Pan (MT1).....	B61313			<b>V-8 8.1 L ENG.</b>			
Connector From Aux. Cooler.....			②A63019	Connector From Aux. Cooler.....			②A63019
Connector From Rad. ....			②A63018	Inlet Fitting To Trans. (Upper).....			A63021
Inlet (Upper); W/16-Bolt Trans. Pan (M30); W/O Aux. Cooler.....	B61267			Inlet From Rad. (Lower).....	B61270		
Inlet Fitting To Trans. (Lower).....			A63027	Outlet Fitting To Trans. (Lower).....			A63021
Outlet (Lower); W/16-Bolt Trans. Pan (M30).....	B61262			Wire Retainer (Connectors & Fittings).....			●A63098
Outlet (Lower); W/17-Bolt Trans. Pan (MT1).....	B61312						
Quick Connect Tube Fitting (Lower).....			A63021	<b>2001</b>			
Quick Connect Tube Fitting (Upper).....			A63021	<b>V-6 4.3 L ENG.; V-8 4.8 L ENG.; V-8 5.3 L ENG.</b>			
Wire Retainer (Connectors & Fittings).....			●A63098	Aux. Cooler Inlet (Pass. Side).....	B61264		
<b>V-8 6.6 L DIESEL ENG.</b>				Aux. Cooler Outlet (Driver Side).....			
Connector From Rad. ....			②A63067	Connector From Rad.; W/Aux. Cooler.....			●A63019
<b>V-8 8.1 L ENG.</b>				Connector From Rad.; W/O Aux. Cooler.....			
Connector From Aux. Cooler.....			②A63019	Connector From Rad.; W/O Aux. Cooler.....			●A63018
Inlet Fitting To Trans. (Upper).....			A63021	Inlet (Upper); W/O Aux. Cooler.....	B61267		
Inlet From Rad. (Lower).....	B61270			Inlet Fitting To Trans. (Upper).....			A63021
Outlet (Lower).....	B61262			Outlet (Lower).....			
Outlet Fitting To Trans. (Lower).....			A63021	Outlet Fitting To Trans. (Lower).....			A63006

② Two Required.  
③ Three Required.

④ Four Required.  
⑤ Five Required.

⑥ Six Required.  
⑦ Seven Required.

✂ Cut To Fit.  
● As Required.

See Pages 1 - 10 for Engine Oil Cooler Applications.

## Transmission Oil Cooler Assemblies for Passenger Cars &amp; Light Trucks

Application	Assembly Number	Hoses & Tubes	Connectors & Fittings	Application	Assembly Number	Hoses & Tubes	Connectors & Fittings
<b>CHEVROLET - Continued</b>				<b>CHEVROLET - Continued</b>			
<b>SILVERADO SERIES PICKUP - Continued</b>				<b>SILVERADO SERIES PICKUP - Continued</b>			
<b>2001 - Continued</b>				<b>2000 - Continued</b>			
<b>V-6 4.3 L ENG.; V-8 4.8 L ENG.; V-8 5.3 L ENG. - Continued</b>				<b>V-8 5.3 L ENG. - Continued</b>			
Wire Retainer (Connectors & Fittings).....			●A63098	Aux. Cooler Outlet (Driver Side); 2500.....	B61265		
<b>V-8 6.0 L ENG.</b>				Connector From Rad.; W/Aux. Cooler.....			●A63019
Aux. Cooler Inlet (Driver Side); W/17-Bolt Trans. Pan (MT1).....	B61263			Connector From Rad.; W/O Aux. Cooler.....			●A63018
Aux. Cooler Inlet (Pass. Side); W/16-Bolt Trans. Pan (M30).....	B61264			Inlet (Upper); W/O Aux. Cooler.....	B61267		A63021
Aux. Cooler Outlet (Driver Side); W/16-Bolt Trans. Pan (M30).....	B61266			Inlet Fitting To Trans. (Upper).....			A63006
Aux. Cooler Outlet (Pass. Side); W/17-Bolt Trans. Pan (MT1).....	B61313			Outlet (Lower).....	B61262		
Connector From Aux. Cooler.....			②A63019	Outlet Fitting To Trans. (Lower).....			●A63098
Connector From Rad. ....			②A63018	Wire Retainer (Connectors & Fittings).....			
Inlet (Upper); W/16-Bolt Trans. Pan (M30); W/O Aux. Cooler.....	B61267			<b>V-8 6.0 L ENG.</b>			
Inlet Fitting To Trans. Case (Lower); W/17-Bolt Trans. Pan (MT1).....			A63027	Aux. Cooler Inlet (Driver Side).....	B61313		
Outlet (Lower); W/16-Bolt Trans. Pan (M30).....	B61262			Aux. Cooler Supply From Rad. (Upper); 2nd Design.....	B61263		②A63019
Outlet (Lower); W/17-Bolt Trans. Pan (MT1).....	B61312			Connector From Aux. Cooler.....			②A63018
Outlet Fitting To Trans. (Lower); W/16-Bolt Trans. Pan (M30).....			A63006	Connector From Rad. ....			A63027
Quick Connect Tube Fitting (Lower); W/16-Bolt Trans. Pan (M30).....			A63021	Inlet Fitting To Trans. Case (Lower) .....			A63021
Quick Connect Tube Fitting (Lower); W/17-Bolt Trans. Pan (MT1).....			A63021	Outlet From Rad. (Lower); 2nd Design.....	B61312		
Quick Connect Tube Fitting (Upper); W/16-Bolt Trans. Pan (M30).....			A63021	Quick Connect Tube Fitting (Lower) .....			A63021
Quick Connect Tube Fitting (Upper); W/17-Bolt Trans. Pan (MT1).....			A63021	Quick Connect Tube Fitting (Upper) .....			A63021
Wire Retainer (Connectors & Fittings).....			●A63098	Wire Retainer (Aux. Cooler).....			●A63098
<b>V-8 6.6 L DIESEL ENG.</b>				<b>1999</b>			
Connector From Aux. Cooler.....			②A63068	<b>V-6 4.3 L ENG.; V-8 4.8 L ENG.</b>			
Connector From Rad. ....			②A63067	Aux. Cooler Inlet (Pass. Side).....	B61264		
Wire Retainer (Aux. Cooler).....			②A63099	Aux. Cooler Outlet (Driver Side).....	B61266		
<b>V-8 8.1 L ENG.</b>				Connector From Rad.; W/Aux. Cooler.....			●A63019
Connector From Aux. Cooler.....			②A63019	Connector From Rad.; W/O Aux. Cooler.....			●A63018
Inlet Fitting To Trans. (Upper).....			A63021	Inlet (Upper); W/O Aux. Cooler.....	B61267		A63021
Inlet From Rad. (Lower).....	B61270			Inlet Fitting To Trans. (Upper).....			A63006
Outlet Fitting To Trans. (Lower).....			A63021	Outlet (Lower).....	B61262		
Wire Retainer (Connectors & Fittings).....			●A63098	Outlet Fitting To Trans. (Lower).....			A63006
<b>2000</b>				Wire Retainer (Connectors & Fittings).....			●A63098
<b>V-6 4.3 L ENG.; V-8 4.8 L ENG.</b>				<b>V-8 5.3 L ENG.</b>			
Aux. Cooler Inlet (Pass. Side).....	B61264			Aux. Cooler Inlet (Pass. Side); 1500, 3500.....	B61264		
Aux. Cooler Outlet (Driver Side).....	B61266			Aux. Cooler Inlet (Pass. Side); 2500.....	B61263		
Connector From Rad.; W/Aux. Cooler.....			●A63019	Aux. Cooler Outlet (Driver Side); 1500, 3500.....	B61266		
Connector From Rad.; W/O Aux. Cooler.....			●A63018	Aux. Cooler Outlet (Driver Side); 2500.....	B61265		
Inlet (Upper); W/O Aux. Cooler.....	B61267			Connector From Rad.; W/Aux. Cooler.....			●A63019
Inlet Fitting To Trans. (Upper).....			A63021	Connector From Rad.; W/O Aux. Cooler.....			●A63018
Outlet (Lower).....	B61262			Inlet (Upper); W/O Aux. Cooler.....	B61267		A63021
Outlet Fitting To Trans. (Lower).....			A63006	Inlet Fitting To Trans. (Upper).....			A63006
Wire Retainer (Connectors & Fittings).....			●A63098	Outlet (Lower).....	B61262		
<b>V-8 5.3 L ENG.</b>				Outlet Fitting To Trans. (Lower).....			A63006
Aux. Cooler Inlet (Pass. Side); 1500, 3500.....	B61264			Wire Retainer (Connectors & Fittings).....			●A63098
Aux. Cooler Inlet (Pass. Side); 2500.....	B61263			<b>V-8 6.0 L ENG.</b>			
Aux. Cooler Outlet (Driver Side); 1500, 3500.....	B61266			Aux. Cooler Inlet (Driver Side).....	B61313		②A63019
				Connector From Aux. Cooler.....			②A63018
				Connector From Rad. ....			A63027
				Inlet Fitting To Trans. Case (Lower) .....			A63021
				Quick Connect Tube Fitting (Lower) .....			

② Two Required.  
③ Three Required.

④ Four Required.  
⑤ Five Required.

⑥ Six Required.  
⑦ Seven Required.

≠ Cut To Fit.  
● As Required.

See Pages 1 - 10 for Engine Oil Cooler Applications.

## Transmission Oil Cooler Assemblies for Passenger Cars & Light Trucks

Application	Assembly Number	Hoses & Tubes	Connectors & Fittings	Application	Assembly Number	Hoses & Tubes	Connectors & Fittings
<b>CHEVROLET - Continued</b>				<b>CHEVROLET - Continued</b>			
<b>SILVERADO SERIES PICKUP - Continued</b>				<b>SUBURBAN - Continued</b>			
<b>1999 - Continued</b>				<b>2003 - Continued</b>			
<b>V-8 6.0 L ENG. - Continued</b>				<b>V-8 6.0 L ENG. - Continued</b>			
Quick Connect Tube Fitting (Upper).....			A63021	Connector From Aux. Cooler.....			②A63019
Wire Retainer (Aux. Cooler).....			●A63098	Connector From Rad. ....			②A63018
<b>V-8 6.5 L DIESEL ENG.</b>				<b>2003 - Continued</b>			
Aux. Cooler Inlet (Pass. Side); 3500HD.....	A61027			Inlet (Upper); W/16-Bolt Trans. Pan (M30); W/O Aux. Cooler.....	B61267		
Aux. Cooler Inlet (Pass. Side); Exc. 3500HD.....	A61028			Inlet Fitting To Trans. (Lower).....			A63027
Aux. Cooler Outlet (Driver Side); 3500HD.....	B61108			Outlet (Lower); W/16-Bolt Trans. Pan (M30).....	B61262		
Aux. Cooler Outlet (Driver Side); Exc. 3500HD.....	B61107			Outlet (Lower); W/17-Bolt Trans. Pan (MT1).....	B61312		
Connector From Aux. Cooler.....			②A63019	Quick Connect Tube Fitting (Lower).....			A63021
Inlet Fitting To Trans. (Upper); Service Item.....			A63007	Quick Connect Tube Fitting (Upper).....			A63021
Inlet Fitting To Trans. (Upper); W/Factory Inst. Fitting.....			A63006	Wire Retainer (Connectors & Fittings).....			●A63098
Inlet Fitting To Trans. Case (Upper); W/Factory Inst. Fitting.....			A63027	<b>V-8 8.1 L ENG.</b>			
Inlet Tube (Upper); Service Item; Remove Current Line & Trans. Fittings. Replace Using Bulk Tubing & Service Item Listed.....		⊗A63005		Connector From Aux. Cooler.....			②A63019
Outlet Fitting To Trans. (Lower).....			A63006	Connector From Rad. ....			②A63019
Quick Connect Tube Fitting (Lower).....			A63021	Inlet Fitting To Trans. Case (Lower).....			A63027
Quick Connect Tube Fitting (Upper).....			A63021	Inlet From Rad. (Lower).....	B61270		
Tube Nut; Service Item.....			A63021	Quick Connect Tube Fitting (Lower).....			A63021
Wire Retainer (Connectors & Fittings); W/3/8" Retainer.....			●A63098	Quick Connect Tube Fitting (Upper).....			A63021
Wire Retainer (Connectors & Fittings); W/5/8" Retainer.....			●A63099	Wire Retainer (Connectors & Fittings).....			●A63098
<b>SSR</b>				<b>2002-2001</b>			
<b>2003</b>				<b>V-8 5.3 L ENG.</b>			
<b>V-8 5.3 L ENG.</b>				Aux. Cooler Inlet (Pass. Side).....			
Connector From Rad.; W/O Beveled Washer.....			A63065	Aux. Cooler Outlet (Driver Side).....	B61264		B61266
Inlet Fitting To Trans. (Upper).....			A63021	Connector From Rad.; W/Aux. Cooler.....			●A63019
Outlet Fitting To Trans. (Lower).....			A63021	Connector From Rad.; W/O Aux. Cooler.....			●A63018
Wire Retainer (Fittings).....			●A63098	Inlet (Upper); W/O Aux. Cooler.....	B61267		
<b>SUBURBAN</b>				Inlet Fitting To Trans. (Upper).....			
<b>2003</b>				Outlet (Lower).....			
<b>V-8 5.3 L ENG.</b>				Outlet Fitting To Trans. (Lower).....			
Aux. Cooler Inlet (Pass. Side).....	B61264			Wire Retainer (Connectors & Fittings).....			●A63098
Aux. Cooler Outlet (Driver Side).....	B61266			<b>V-8 6.0 L ENG.</b>			
Connector From Rad.; W/Aux. Cooler.....			●A63019	Aux. Cooler Inlet (Driver Side); W/17-Bolt Trans. Pan (MT1).....	B61263		
Connector From Rad.; W/O Aux. Cooler.....			●A63018	Aux. Cooler Inlet (Pass. Side); W/16-Bolt Trans. Pan (M30).....	B61264		
Inlet (Upper); W/O Aux. Cooler.....	B61267			Aux. Cooler Outlet (Driver Side); W/16-Bolt Trans. Pan (M30).....	B61266		
Inlet Fitting To Trans. (Upper).....			A63021	Aux. Cooler Outlet (Pass. Side); W/17-Bolt Trans. Pan (MT1).....	B61313		
Outlet (Lower).....	B61262			Connector From Aux. Cooler.....			②A63019
Outlet Fitting To Trans. (Lower).....			A63006	Connector From Rad. ....			②A63018
Wire Retainer (Connectors & Fittings).....			●A63098	Inlet (Upper); W/16-Bolt Trans. Pan (M30); W/O Aux. Cooler.....	B61267		
<b>V-8 6.0 L ENG.</b>				Inlet Fitting To Trans. (Lower).....			
Aux. Cooler Inlet (Driver Side); W/17-Bolt Trans. Pan (MT1).....	B61263			Outlet (Lower); W/16-Bolt Trans. Pan (M30).....	B61262		
Aux. Cooler Inlet (Pass. Side); W/16-Bolt Trans. Pan (M30).....	B61264			Outlet (Lower); W/17-Bolt Trans. Pan (MT1).....	B61312		
Aux. Cooler Outlet (Driver Side); W/16-Bolt Trans. Pan (M30).....	B61266			Quick Connect Tube Fitting (Lower).....			A63021
Aux. Cooler Outlet (Pass. Side); W/17-Bolt Trans. Pan (MT1).....	B61313			Quick Connect Tube Fitting (Upper).....			A63021
				Wire Retainer (Connectors & Fittings).....			
				●A63098			
				<b>V-8 8.1 L ENG.</b>			
				Connector From Aux. Cooler.....			
				Connector From Rad. ....			

② Two Required.                      ④ Four Required.                      ⑥ Six Required.                      ✕ Cut To Fit.  
 ③ Three Required.                    ⑤ Five Required.                      ⑦ Seven Required.                    ● As Required.

See Pages 1 - 10 for Engine Oil Cooler Applications.

## Transmission Oil Cooler Assemblies for Passenger Cars &amp; Light Trucks

Application	Assembly Number	Hoses & Tubes	Connectors & Fittings	Application	Assembly Number	Hoses & Tubes	Connectors & Fittings
<b>CHEVROLET - Continued</b>				<b>CHEVROLET - Continued</b>			
<b>SUBURBAN - Continued</b>				<b>SUBURBAN - Continued</b>			
<b>2002-2001 - Continued</b>				<b>1999-1998 - Continued</b>			
<b>V-8 8.1 L ENG. - Continued</b>				<b>V-8 5.7 L ENG. - Continued</b>			
Inlet Fitting To Trans. (Lower).....			A63027	Inlet Tube (Upper); Service Item; Remove Current Line & Trans. Fittings. Replace Using Bulk Tubing & Service Item Listed.....		≡A63005	
Inlet From Rad. (Lower).....	B61270			Outlet (Lower); W/O Aux. Cooler; W/16-Bolt Trans. Pan (M30).....	B61055		
Quick Connect Tube Fitting (Lower) .....			A63021	Outlet Fitting To Trans. (Lower); W/16-Bolt Trans. Pan (M30).....			A63007
Quick Connect Tube Fitting (Upper) .....			A63021	Outlet Fitting To Trans. (Lower); W/17-Bolt Trans. Pan (MT1).....			A63006
Wire Retainer (Connectors & Fittings) .....			●A63098	Quick Connect Tube Fitting (Lower) .....			A63021
<b>2000</b>				<b>V-8 5.7 L ENG. - Continued</b>			
<b>V-8 5.3 L ENG.</b>				<b>1999-1998 - Continued</b>			
Aux. Cooler Inlet (Pass. Side); 1500.....	B61264			Quick Connect Tube Fitting (Upper) .....			A63021
Aux. Cooler Inlet (Pass. Side); 2500.....	B61263			Tube Nut; Service Item.....			ⓄA63013
Aux. Cooler Outlet (Driver Side); 1500.....	B61266			Wire Retainer (Connectors & Fittings); W/3/8" Retainer.....			●A63098
Aux. Cooler Outlet (Driver Side); 2500.....	B61265			Wire Retainer (Connectors & Fittings); W/5/8" Retainer.....			●A63099
Connector From Rad.; W/Aux. Cooler.....			●A63019	<b>V-8 6.5 L DIESEL ENG.</b>			
Connector From Rad.; W/O Aux. Cooler.....			●A63018	Aux. Cooler Inlet (Pass. Side).....	A61028		
Inlet (Upper); W/O Aux. Cooler.....	B61267			Aux. Cooler Outlet (Driver Side).....	B61107		
Inlet Fitting To Trans. (Upper).....			A63021	Connector From Aux. Cooler.....			ⓄA63019
Outlet (Lower).....	B61262			Inlet Fitting To Trans. (Upper); Service Item.....			A63007
Outlet Fitting To Trans. (Lower).....			A63006	Inlet Fitting To Trans. (Upper); W/Factory Inst. Fitting.....			A63006
Wire Retainer (Connectors & Fittings) .....			●A63098	Inlet Fitting To Trans. Case (Upper); W/Factory Inst. Fitting.....			A63027
<b>V-8 6.0 L ENG.</b>				<b>V-8 6.5 L DIESEL ENG. - Continued</b>			
Aux. Cooler Inlet (Driver Side).....	B61313			Inlet Tube (Upper); Service Item; Remove Current Line & Trans. Fittings. Replace Using Bulk Tubing & Service Item Listed.....		≡A63005	
Aux. Cooler Supply From Rad. (Upper); 2nd Design.....	B61263			Outlet Fitting To Trans. (Lower).....			A63006
Connector From Aux. Cooler.....			ⓄA63019	Quick Connect Tube Fitting (Lower) .....			A63021
Connector From Rad.....			ⓄA63018	Quick Connect Tube Fitting (Upper) .....			A63021
Inlet Fitting To Trans. Case (Lower) .....			A63027	Tube Nut; Service Item.....			ⓄA63013
Outlet From Rad. (Lower); 2nd Design .....	B61312			Wire Retainer (Connectors & Fittings); W/3/8" Retainer.....			●A63098
Quick Connect Tube Fitting (Lower) .....			A63021	Wire Retainer (Connectors & Fittings); W/5/8" Retainer.....			●A63099
Quick Connect Tube Fitting (Upper) .....			A63021	<b>V-8 7.4 L ENG.</b>			
Wire Retainer (Aux. Cooler).....			●A63098	Aux. Cooler Inlet (Pass. Side).....	B61025		
<b>1999-1998</b>				Aux. Cooler Outlet (Driver Side).....	B61026		
<b>V-8 5.7 L ENG.</b>				Connector From Aux. Cooler.....			ⓄA63019
Aux. Cooler Inlet (Pass. Side); W/16-Bolt Trans. Pan (M30).....	B61056			Inlet Fitting To Trans. (Upper); Service Item.....			A63007
Aux. Cooler Inlet (Pass. Side); W/17-Bolt Trans. Pan (MT1).....	A61028			Inlet Fitting To Trans. (Upper); W/Factory Inst. Fitting.....			A63006
Aux. Cooler Outlet (Driver Side); W/16-Bolt Trans. Pan (M30).....	B61058			Inlet Fitting To Trans. Case (Upper); W/Factory Inst. Fitting.....			A63027
Aux. Cooler Outlet (Driver Side); W/17-Bolt Trans. Pan (MT1).....	B61029			Inlet Tube (Upper); Service Item; Remove Current Line & Trans. Fittings. Replace Using Bulk Tubing & Service Item Listed.....		≡A63005	
Connector From Aux. Cooler.....			ⓄA63019	Outlet Fitting To Trans. (Lower).....			A63006
Inlet (Upper); W/O Aux. Cooler; W/16-Bolt Trans. Pan (M30).....	B61057			Quick Connect Tube Fitting (Lower) .....			A63021
Inlet Fitting To Trans. (Upper); Service Item.....			A63007	Quick Connect Tube Fitting (Upper) .....			A63021
Inlet Fitting To Trans. (Upper); W/16-Bolt Trans. Pan (M30).....			A63007	Tube Nut; Service Item.....			ⓄA63013
Inlet Fitting To Trans. (Upper); W/Factory Inst. Fitting; W/17-Bolt Trans. Pan (MT1).....			A63006	Wire Retainer (Connectors & Fittings); W/3/8" Retainer.....			●A63098
Inlet Fitting To Trans. Case (Upper); W/Factory Inst. Fitting; W/17-Bolt Trans. Pan (MT1).....			A63027	Wire Retainer (Connectors & Fittings); W/5/8" Retainer.....			●A63099

Ⓞ Two Required.  
Ⓜ Three Required.

Ⓞ Four Required.  
Ⓜ Five Required.

Ⓞ Six Required.  
Ⓜ Seven Required.

≡ Cut To Fit.  
● As Required.

See Pages 1 - 10 for Engine Oil Cooler Applications.

## Transmission Oil Cooler Assemblies for Passenger Cars & Light Trucks

Application	Assembly Number	Hoses & Tubes	Connectors & Fittings	Application	Assembly Number	Hoses & Tubes	Connectors & Fittings
<b>CHEVROLET - Continued</b>				<b>CHEVROLET - Continued</b>			
<b>SUBURBAN - Continued</b>				<b>SUBURBAN - Continued</b>			
<b>1997</b>				<b>1997 - Continued</b>			
<b>V-8 5.7 L ENG.</b>				<b>V-8 7.4 L ENG. - Continued</b>			
Aux. Cooler Inlet (Pass. Side); W/16-Bolt Trans. Pan (M30).....	B61240			Inlet Tube (Upper); Service Item; Remove Current Line & Trans. Fittings. Replace Using Bulk Tubing & Service Item Listed.....		≈A63005	
Aux. Cooler Inlet (Pass. Side); W/17-Bolt Trans. Pan (MT1).....	A61028			Outlet Fitting To Trans. (Lower).....			A63006
Aux. Cooler Outlet (Driver Side); W/16-Bolt Trans. Pan (M30).....	B61252			Quick Connect Tube Fitting (Lower) .....			A63021
Aux. Cooler Outlet (Driver Side); W/17-Bolt Trans. Pan (MT1).....	B61029			Quick Connect Tube Fitting (Upper) .....			A63021
Connector From Aux. Cooler.....			②A63019	Tube Nut; Service Item.....			②A63013
Inlet Fitting To Trans. (Upper); Service Item.....			A63007	Wire Retainer (Connectors & Fittings); W/3/8" Retainer.....			●A63098
Inlet Fitting To Trans. (Upper); W/16-Bolt Trans. Pan (M30).....			A63007	Wire Retainer (Connectors & Fittings); W/5/8" Retainer.....			●A63099
Inlet Fitting To Trans. (Upper); W/Factory Inst. Fitting; W/17-Bolt Trans. Pan (MT1).....			A63006	<b>1996</b>			
Inlet Fitting To Trans. Case (Upper); W/Factory Inst. Fitting; W/17-Bolt Trans. Pan (MT1).....			A63027	<b>V-8 5.7 L ENG.</b>			
Inlet Tube (Upper); Service Item; Remove Current Line & Trans. Fittings. Replace Using Bulk Tubing & Service Item Listed.....			≈A63005	Aux. Cooler Inlet (Pass. Side); W/16-Bolt Trans. Pan (M30).....	B61240		
Outlet Fitting To Trans. (Lower); W/16-Bolt Trans. Pan (M30).....			A63007	Aux. Cooler Inlet (Pass. Side); W/17-Bolt Trans. Pan (MT1).....	A61028		
Outlet Fitting To Trans. (Lower); W/17-Bolt Trans. Pan (MT1).....			A63006	Aux. Cooler Outlet (Driver Side); W/16-Bolt Trans. Pan (M30).....	B61252		
Quick Connect Tube Fitting (Lower) .....			A63021	Aux. Cooler Outlet (Driver Side); W/17-Bolt Trans. Pan (MT1).....	B61253		
Quick Connect Tube Fitting (Upper); W/Factory Inst. Fitting.....			A63021	Connector From Aux. Cooler.....			②A63019
Tube Nut; Service Item.....			②A63013	Inlet Fitting To Trans. (Upper); Service Item.....			A63007
Wire Retainer (Connectors & Fittings); W/3/8" Retainer.....			●A63098	Inlet Fitting To Trans. (Upper); W/16-Bolt Trans. Pan (M30).....			A63007
Wire Retainer (Connectors & Fittings); W/5/8" Retainer.....			●A63099	Inlet Fitting To Trans. (Upper); W/Factory Inst. Fitting; W/17-Bolt Trans. Pan (MT1).....			A63006
<b>V-8 6.5 L DIESEL ENG.</b>				<b>V-8 5.7 L ENG.</b>			
Aux. Cooler Inlet (Pass. Side).....	A61028			Aux. Cooler Inlet (Pass. Side); W/16-Bolt Trans. Pan (M30).....	B61240		
Aux. Cooler Outlet (Driver Side).....	B61107			Aux. Cooler Inlet (Pass. Side); W/17-Bolt Trans. Pan (MT1).....	A61028		
Connector From Aux. Cooler.....			②A63019	Aux. Cooler Outlet (Driver Side); W/16-Bolt Trans. Pan (M30).....	B61252		
Inlet Fitting To Trans. (Upper); Service Item.....			A63007	Aux. Cooler Outlet (Driver Side); W/17-Bolt Trans. Pan (MT1).....	B61253		
Inlet Fitting To Trans. (Upper); W/Factory Inst. Fitting.....			A63006	Connector From Aux. Cooler.....			②A63019
Inlet Fitting To Trans. Case (Upper); W/Factory Inst. Fitting.....			A63027	Inlet Fitting To Trans. (Upper); Service Item.....			A63007
Inlet Tube (Upper); Service Item; Remove Current Line & Trans. Fittings. Replace Using Bulk Tubing & Service Item Listed.....			≈A63005	Inlet Fitting To Trans. (Upper); W/16-Bolt Trans. Pan (M30).....			A63007
Outlet Fitting To Trans. (Lower).....			A63006	Inlet Tube (Upper); Service Item; Remove Current Line & Trans. Fittings. Replace Using Bulk Tubing & Service Item Listed.....		≈A63005	
Quick Connect Tube Fitting (Lower) .....			A63021	Outlet Fitting To Trans. (Lower); W/16-Bolt Trans. Pan (M30).....			A63007
Quick Connect Tube Fitting (Upper) .....			A63021	Outlet Fitting To Trans. (Lower); W/17-Bolt Trans. Pan (MT1).....			A63006
Tube Nut; Service Item.....			②A63013	Quick Connect Tube Fitting (Lower) .....			A63021
Wire Retainer (Connectors & Fittings); W/3/8" Retainer.....			●A63098	Quick Connect Tube Fitting (Upper); W/Factory Inst. Fitting.....			A63021
Wire Retainer (Connectors & Fittings); W/5/8" Retainer.....			●A63099	Tube Nut; Service Item.....			②A63013
<b>V-8 7.4 L ENG.</b>				<b>V-8 6.5 L DIESEL ENG.</b>			
Aux. Cooler Inlet (Pass. Side).....	B61025			Connector From Aux. Cooler.....			②A63019
Aux. Cooler Outlet (Driver Side).....	B61026			Inlet Fitting To Trans. (Upper); Service Item.....			A63007
Connector From Aux. Cooler.....			②A63019	Inlet Fitting To Trans. (Upper); W/Factory Inst. Fitting.....			A63006
Inlet Fitting To Trans. (Upper); Service Item.....			A63007	Inlet Tube (Upper); Service Item; Remove Current Line & Trans. Fittings. Replace Using Bulk Tubing & Service Item Listed.....		≈A63005	
Inlet Fitting To Trans. (Upper); W/Factory Inst. Fitting.....			A63006	Outlet Fitting To Trans. (Lower).....			A63006
Inlet Fitting To Trans. Case (Upper); W/Factory Inst. Fitting.....			A63027	Quick Connect Tube Fitting (Lower) .....			A63021

② Two Required.      ④ Four Required.      ⑥ Six Required.      ≈ Cut To Fit.  
 ③ Three Required.      ⑤ Five Required.      ⑦ Seven Required.      ● As Required.

See Pages 1 - 10 for Engine Oil Cooler Applications.

## Transmission Oil Cooler Assemblies for Passenger Cars &amp; Light Trucks

Application	Assembly Number	Hoses & Tubes	Connectors & Fittings	Application	Assembly Number	Hoses & Tubes	Connectors & Fittings
<b>CHEVROLET - Continued</b>				<b>CHEVROLET - Continued</b>			
<b>SUBURBAN - Continued</b>				<b>SUBURBAN - Continued</b>			
<b>1996 - Continued</b>				<b>1993 - Continued</b>			
<b>V-8 7.4 L ENG.</b>				<b>V-8 5.7 L ENG. - Continued</b>			
Aux. Cooler Inlet (Pass. Side).....	B61026			Aux. Cooler Inlet (Pass. Side); W/17-Bolt Trans. Pan (MT1) .....	A61172		
Aux. Cooler Outlet (Driver Side).....	B61254		ⓉA63019	Aux. Cooler Outlet (Driver Side); W/16-Bolt Trans. Pan (M30).....	B61211		
Connector From Aux. Cooler.....			A63007	Aux. Cooler Outlet (Driver Side); W/17-Bolt Trans. Pan (MT1) .....	B61235		
Inlet Fitting To Trans. (Upper); Ser- vice Item.....			A63006	Connector "O" Ring.....			●A63091
Inlet Fitting To Trans. (Upper); W/Factory Inst. Fitting.....			A63027	Connector From Aux. Cooler.....			ⓉA63017
Inlet Fitting To Trans. Case (Up- per); W/Factory Inst. Fitting.....			A63006	Inlet (Upper); W/Aux. Cooler .....		≠A63004	
Inlet Tube (Upper); Service Item; Remove Current Line & Trans. Fittings. Replace Using Bulk Tubing & Service Item Listed.....		≠A63005	A63021	Inlet (Upper); W/O Aux. Cooler .....		≠A63004	A63006
Outlet Fitting To Trans. (Lower) .....			A63006	Inlet Fitting To Trans. (Upper).....			A63006
Quick Connect Tube Fitting (Low- er).....			A63021	Outlet (Lower); W/O Aux. Cooler ...			A63006
Quick Connect Tube Fitting (Up- per).....			A63021	Outlet Fitting To Trans. (Lower) .....			●A63011
Tube Nut; Service Item.....			ⓉA63013	Tube Nut.....			●A63110
Wire Retainer (Connectors & Fit- tings); W/3/8" Retainer.....			●A63098	Wire Retainer (Connectors).....			
Wire Retainer (Connectors & Fit- tings); W/5/8" Retainer.....			●A63099				
<b>1995-1994</b>				<b>V-8 7.4 L ENG.</b>			
<b>V-8 5.7 L ENG.</b>				Aux. Cooler Inlet (Pass. Side).....			
Aux. Cooler Inlet (Pass. Side); W/16-Bolt Trans. Pan (M30).....	A61217			Aux. Cooler Outlet (Driver Side).....	B61169		
Aux. Cooler Inlet (Pass. Side); W/17-Bolt Trans. Pan (MT1) .....	A61172			Connector "O" Ring.....	B61159		
Aux. Cooler Outlet (Driver Side); W/16-Bolt Trans. Pan (M30).....	B61211			Connector From Aux. Cooler.....			●A63091
Aux. Cooler Outlet (Driver Side); W/17-Bolt Trans. Pan (MT1) .....	B61235			Inlet (Upper).....			ⓉA63017
Connector "O" Ring.....			●A63091	Inlet Fitting To Trans. (Upper).....			A63006
Connector From Aux. Cooler.....			ⓉA63017	Outlet Fitting To Trans. (Lower) .....			A63006
Inlet (Upper); W/Aux. Cooler .....		≠A63004		Tube Nut.....			●A63011
Inlet (Upper); W/O Aux. Cooler .....		≠A63004		Wire Retainer (Connectors).....			●A63110
Inlet Fitting To Trans. (Upper).....			A63006				
Outlet (Lower); W/O Aux. Cooler ...			A63006				
Outlet Fitting To Trans. (Lower) .....			●A63011				
Tube Nut.....			●A63110				
Wire Retainer (Connectors).....							
<b>V-8 6.5 L DIESEL ENG.</b>				<b>1992</b>			
Aux. Cooler Inlet (Pass. Side).....	A61219			<b>V-8 5.7 L ENG.; V-8 7.4 L ENG.</b>			
Aux. Cooler Outlet (Driver Side).....	B61165			Inlet (Upper).....		≠A63004	
Connector "O" Ring.....			●A63091	Inlet Fitting To Trans. (Upper).....			A63006
Connector From Aux. Cooler.....			ⓉA63017	Outlet (Lower).....		≠A63004	
Inlet (Upper).....			≠A63004	Outlet Fitting To Trans. (Lower) .....			A63006
Inlet Fitting To Trans. (Upper).....			A63006	Tube Nut.....			ⓉA63011
Outlet Fitting To Trans. (Lower) .....			A63006				
Tube Nut.....			●A63011				
Wire Retainer (Connectors).....			●A63110				
<b>V-8 7.4 L ENG.</b>				<b>1991-1988</b>			
Aux. Cooler Inlet (Pass. Side).....	B61169			<b>V-8 5.7 L ENG.; V-8 6.2 L DIESEL ENG.; V-8 7.4 L ENG.</b>			
Aux. Cooler Outlet (Driver Side).....	B61159			Inlet (Upper).....		≠A63004	
Connector "O" Ring.....			●A63091	Inlet Fitting To Trans. (Upper).....			A63006
Connector From Aux. Cooler.....			ⓉA63017	Outlet (Lower).....		≠A63004	
Inlet (Upper).....			≠A63004	Outlet Fitting To Trans. (Lower) .....			A63006
Inlet Fitting To Trans. (Upper).....			A63006	Tube Nut.....			ⓉA63011
Outlet Fitting To Trans. (Lower) .....			A63006				
Tube Nut.....			●A63011				
Wire Retainer (Connectors).....			●A63110				
<b>V-8 7.4 L ENG.</b>				<b>1987-1985</b>			
Aux. Cooler Inlet (Pass. Side).....	B61169			<b>V-8 5.0 L ENG.; V-8 5.7 L ENG.; V-8 6.2 L DIESEL ENG.;</b>			
Aux. Cooler Outlet (Driver Side).....	B61159			<b>V-8 7.4 L ENG.</b>			
Connector "O" Ring.....			●A63091	Inlet (Upper).....		≠A63004	
Connector From Aux. Cooler.....			ⓉA63017	Inlet Fitting To Trans. (Upper).....			A63006
Inlet (Upper).....			≠A63004	Outlet (Lower).....		≠A63004	
Inlet Fitting To Trans. (Upper).....			A63006	Outlet Fitting To Trans. (Lower) .....			A63006
Outlet Fitting To Trans. (Lower) .....			A63006	Tube Nut.....			ⓉA63011
Tube Nut.....			●A63011				
Wire Retainer (Connectors).....			●A63110				
<b>1993</b>				<b>TAHOE</b>			
<b>V-8 5.7 L ENG.</b>				<b>2003-2001</b>			
Aux. Cooler Inlet (Pass. Side); W/16-Bolt Trans. Pan (M30).....	A61217			<b>V-8 4.8 L ENG.; V-8 5.3 L ENG.</b>			
				Aux. Cooler Inlet (Pass. Side).....	B61264		
				Aux. Cooler Outlet (Driver Side).....	B61266		
				Connector From Rad.; W/Aux. Cooler.....			●A63019
				Connector From Rad.; W/O Aux. Cooler.....			●A63018
				Inlet (Upper); W/O Aux. Cooler .....	B61267		
				Inlet Fitting To Trans. (Upper).....			A63021
				Outlet (Lower).....	B61262		
				Outlet Fitting To Trans. (Lower) .....			A63006
				Wire Retainer (Connectors & Fit- tings).....			●A63098

Ⓣ Two Required.  
Ⓝ Three Required.

Ⓞ Four Required.  
Ⓟ Five Required.

Ⓠ Six Required.  
Ⓡ Seven Required.

≠ Cut To Fit.  
● As Required.

See Pages 1 - 10 for Engine Oil Cooler Applications.



# Transmission Oil Cooler Assemblies for Passenger Cars & Light Trucks

Application	Assembly Number	Hoses & Tubes	Connectors & Fittings	Application	Assembly Number	Hoses & Tubes	Connectors & Fittings
<b>CHEVROLET - Continued</b>				<b>CHEVROLET - Continued</b>			
<b>TAHOE - Continued</b>				<b>TAHOE - Continued</b>			
<b>2000</b>				<b>1999-1998 - Continued</b>			
<b>V-8 4.8 L ENG.; V-8 5.3 L ENG.</b>				<b>V-8 6.5 L DIESEL ENG. - Continued</b>			
Aux. Cooler Inlet (Pass. Side).....	B61264			Inlet Tube (Upper); Service Item; Remove Current Line & Trans. Fittings. Replace Using Bulk Tubing & Service Item Listed.....		≠A63005	
Aux. Cooler Outlet (Driver Side).....	B61266			Outlet Fitting To Trans. (Lower) .....			A63006
Connector From Rad.; W/Aux. Cooler .....			●A63019	Quick Connect Tube Fitting (Low- er) .....			A63021
Connector From Rad.; W/O Aux. Cooler .....			●A63018	Quick Connect Tube Fitting (Up- per) .....			A63021
Inlet (Upper); W/O Aux. Cooler .....	B61267		A63021	Tube Nut; Service Item .....			②A63013
Inlet Fitting To Trans. (Upper).....				Wire Retainer (Connectors & Fit- tings); W/3/8" Retainer.....			●A63098
Outlet (Lower).....	B61262		A63006	Wire Retainer (Connectors & Fit- tings); W/5/8" Retainer.....			●A63099
Outlet Fitting To Trans. (Lower) .....							
Wire Retainer (Connectors & Fit- tings).....			●A63098				
<b>V-8 5.7 L ENG.</b>				<b>1997</b>			
Aux. Cooler Inlet (Pass. Side).....	B61056			<b>V-8 5.7 L ENG.</b>			
Aux. Cooler Outlet (Driver Side).....	B61058			Aux. Cooler Inlet (Pass. Side).....	B61240		
Connector From Aux. Cooler.....			②A63019	Aux. Cooler Outlet (Driver Side).....	B61252		
Inlet (Upper); W/O Aux. Cooler .....	B61057		A63007	Connector From Aux. Cooler.....			②A63019
Inlet Fitting To Trans. (Upper).....				Inlet Fitting To Trans. (Upper); Ser- vice Item.....			A63007
Inlet Tube (Upper); Service Item; Remove Current Line & Trans. Fittings. Replace Using Bulk Tubing & Service Item Listed.....			≠A63005	Inlet Tube (Upper); Service Item; Remove Current Line & Trans. Fittings. Replace Using Bulk Tubing & Service Item Listed.....			≠A63005
Outlet (Lower); W/O Aux. Cooler .....	B61055			Outlet Fitting To Trans. (Lower) .....			A63007
Outlet Fitting To Trans. (Lower) .....			A63007	Quick Connect Tube Fitting (Low- er) .....			A63021
Quick Connect Tube Fitting (Low- er) .....			A63021	Quick Connect Tube Fitting (Up- per) .....			A63021
Quick Connect Tube Fitting (Up- per) .....			A63021	Quick Connect Tube Fitting (Up- per) .....			A63021
Tube Nut; Service Item .....			②A63013	Tube Nut; Service Item .....			②A63013
Wire Retainer (Connectors & Fit- tings); W/3/8" Retainer.....			●A63098	Wire Retainer (Connectors & Fit- tings); W/3/8" Retainer.....			●A63098
Wire Retainer (Connectors & Fit- tings); W/5/8" Retainer.....			●A63099	Wire Retainer (Connectors & Fit- tings); W/5/8" Retainer.....			●A63099
<b>1999-1998</b>				<b>V-8 6.5 L DIESEL ENG.</b>			
<b>V-8 5.7 L ENG.</b>				Aux. Cooler Inlet (Pass. Side).....			
Aux. Cooler Inlet (Pass. Side).....	B61056			Aux. Cooler Outlet (Driver Side).....	B61107		
Aux. Cooler Outlet (Driver Side).....	B61058			Connector From Aux. Cooler.....			②A63019
Connector From Aux. Cooler.....			②A63019	Inlet Fitting To Trans. (Upper); Ser- vice Item.....			A63007
Inlet (Upper); W/O Aux. Cooler .....	B61057		A63007	Inlet Fitting To Trans. (Upper); W/Factory Inst. Fitting.....			A63006
Inlet Fitting To Trans. (Upper).....				Inlet Fitting To Trans. Case (Up- per); W/Factory Inst. Fitting.....			A63027
Inlet Tube (Upper); Service Item; Remove Current Line & Trans. Fittings. Replace Using Bulk Tubing & Service Item Listed.....			≠A63005	Inlet Tube (Upper); Service Item; Remove Current Line & Trans. Fittings. Replace Using Bulk Tubing & Service Item Listed.....			≠A63005
Outlet (Lower); W/O Aux. Cooler .....	B61055			Outlet Fitting To Trans. (Lower) .....			A63006
Outlet Fitting To Trans. (Lower) .....			A63007	Quick Connect Tube Fitting (Low- er) .....			A63021
Quick Connect Tube Fitting (Low- er) .....			A63021	Quick Connect Tube Fitting (Low- er) .....			A63021
Quick Connect Tube Fitting (Up- per) .....			②A63013	Quick Connect Tube Fitting (Up- per) .....			A63021
Tube Nut; Service Item .....			●A63098	Tube Nut; Service Item .....			②A63013
Wire Retainer (Connectors & Fit- tings); W/3/8" Retainer.....			●A63098	Wire Retainer (Connectors & Fit- tings); W/3/8" Retainer.....			●A63098
Wire Retainer (Connectors & Fit- tings); W/5/8" Retainer.....			●A63099	Wire Retainer (Connectors & Fit- tings); W/5/8" Retainer.....			●A63099
<b>V-8 6.5 L DIESEL ENG.</b>				<b>1996</b>			
Aux. Cooler Inlet (Pass. Side).....	A61028			<b>V-8 5.7 L ENG.</b>			
Aux. Cooler Outlet (Driver Side).....	B61107			Aux. Cooler Inlet (Pass. Side); W/16-Bolt Trans. Pan (M30).....	B61240		
Connector From Aux. Cooler.....			②A63019	Aux. Cooler Inlet (Pass. Side); W/17-Bolt Trans. Pan (MT1) .....	A61028		
Inlet Fitting To Trans. (Upper); Ser- vice Item.....			A63007	Aux. Cooler Outlet (Driver Side); W/16-Bolt Trans. Pan (M30).....	B61252		
Inlet Fitting To Trans. (Upper); W/Factory Inst. Fitting.....			A63006				
Inlet Fitting To Trans. Case (Up- per); W/Factory Inst. Fitting.....			A63027				

② Two Required.  
③ Three Required.

④ Four Required.  
⑤ Five Required.

⑥ Six Required.  
⑦ Seven Required.

≠ Cut To Fit.  
● As Required.

See Pages 1 - 10 for Engine Oil Cooler Applications.

## Transmission Oil Cooler Assemblies for Passenger Cars &amp; Light Trucks

Application	Assembly Number	Hoses & Tubes	Connectors & Fittings	Application	Assembly Number	Hoses & Tubes	Connectors & Fittings
<b>CHEVROLET - Continued</b>				<b>CHEVROLET - Continued</b>			
<b>TAHOE - Continued</b>				<b>TRAILBLAZER - Continued</b>			
<b>1996 - Continued</b>				<b>2004-2003 - Continued</b>			
V-8 5.7 L ENG. - Continued				6-CYL. 4.2 L ENG. - Continued			
Aux. Cooler Outlet (Driver Side);				Outlet Fitting To Trans. (Upper).....			A63021
W/17-Bolt Trans. Pan (MT1).....	B61253		②A63019	Wire Retainer (Connectors & Fit-			●A63098
Connector From Aux. Cooler.....			A63007	tings).....			
Inlet Fitting To Trans. (Upper); Ser-							
vice Item.....				V-8 5.3 L ENG.			
Inlet Tube (Upper); Service Item;				Aux. Cooler Inlet (Pass. Side).....	B61264		
Remove Current Line & Trans.				Aux. Cooler Outlet (Driver Side).....	B61266		
Fittings. Replace Using Bulk				Connector From Rad.; W/Aux.			
Tubing & Service Item Listed.....		≡A63005		Cooler.....			●A63019
Outlet Fitting To Trans. (Lower).....			A63007	Connector From Rad.; W/O Aux.			●A63018
Quick Connect Tube Fitting (Low-				Cooler.....			
er).....				Inlet (Upper); W/O Aux. Cooler.....	B61267		
Quick Connect Tube Fitting (Up-				Inlet Fitting To Trans. (Upper).....			A63021
per).....				Outlet (Lower).....	B61262		
Tube Nut; Service Item.....				Outlet Fitting To Trans. (Lower).....			A63006
Wire Retainer (Connectors & Fit-				Wire Retainer (Connectors & Fit-			●A63098
tings); W/3/8" Retainer.....			●A63098	tings).....			
Wire Retainer (Connectors & Fit-			●A63099				
tings); W/5/8" Retainer.....				<b>2002</b>			
<b>V-8 6.5 L DIESEL ENG.</b>				6-CYL. 4.2 L ENG.			
Connector From Aux. Cooler.....			②A63019	Inlet Fitting To Trans. (Lower).....			A63021
Inlet Fitting To Trans. (Upper); Ser-			A63007	Outlet Fitting To Trans. (Upper).....			A63021
vice Item.....				Wire Retainer (Connectors & Fit-			●A63098
Inlet Fitting To Trans. (Upper);				tings).....			
W/Factory Inst. Fitting.....			A63006				
Inlet Tube (Upper); Service Item;				<b>VENTURE</b>			
Remove Current Line & Trans.				<b>2003-2000</b>			
Fittings. Replace Using Bulk				V-6 3.4 L ENG.			
Tubing & Service Item Listed.....		≡A63005		Connector From Rad. ....			②A63064
Outlet Fitting To Trans. (Lower).....			A63006	Inlet Fitting To Trans. (Upper).....			A63021
Quick Connect Tube Fitting (Low-				Outlet Fitting To Trans. (Lower).....			A63021
er).....				Wire Retainer (Connectors & Fit-			●A63098
Quick Connect Tube Fitting (Up-				tings).....			
per); W/Factory Inst. Fitting.....				<b>1999-1997</b>			
Tube Nut; Service Item.....				V-6 3.4 L ENG.			
Wire Retainer (Connectors & Fit-				Inlet Fitting To Trans. (Lower).....			A63007
tings); W/3/8" Retainer.....			●A63098				
Wire Retainer (Connectors & Fit-			●A63099				
tings); W/5/8" Retainer.....				<b>CHRYSLER</b>			
<b>1995</b>				<b>CIRRUS</b>			
V-8 5.7 L ENG.				<b>2000</b>			
Aux. Cooler Inlet (Pass. Side).....	A61217			V-6 2.5 L ENG.			
Aux. Cooler Outlet (Driver Side).....	B61211		●A63091	Inlet Hose (Pass. Side).....	B61038		
Connector "O" Ring.....			②A63017				
Connector From Aux. Cooler.....				<b>1999-1998</b>			
Inlet (Upper); W/Aux. Cooler.....			≡A63004	V-6 2.5 L ENG.			
Inlet (Upper); W/O Aux. Cooler.....			≡A63004	Inlet (Upper).....	B61038		
Inlet Fitting To Trans. (Upper).....				Outlet (Lower).....	A61039		
Outlet (Lower); W/O Aux. Cooler.....							
Outlet Fitting To Trans. (Lower).....				<b>1997</b>			
Tube Nut.....				4-CYL. 2.4 L ENG.			
Wire Retainer (Connectors).....				Inlet (Pass. Side).....	A61079		
				Outlet (Driver Side).....	A61080		
				V-6 2.5 L ENG.			
				Inlet (Upper).....	B61038		
				Outlet (Lower).....	A61039		
				<b>1996-1995</b>			
				4-CYL. 2.4 L ENG.			
				Aux. Cooler Inlet Tube (Pass.			
				Side).....	A61040		
				Aux. Cooler Outlet Tube (Driver			
				Side).....	A61041		
				Inlet (Pass. Side).....	A61079		

② Two Required.  
③ Three Required.

④ Four Required.  
⑤ Five Required.

⑥ Six Required.  
⑦ Seven Required.

≡ Cut To Fit.  
● As Required.

See Pages 1 - 10 for Engine Oil Cooler Applications.

# Transmission Oil Cooler Assemblies for Passenger Cars & Light Trucks

Application	Assembly Number	Hoses & Tubes	Connectors & Fittings	Application	Assembly Number	Hoses & Tubes	Connectors & Fittings
<b>CHRYSLER - Continued</b>				<b>CHRYSLER - Continued</b>			
<b>CIRRUS - Continued</b>				<b>IMPERIAL</b>			
<b>1996-1995 - Continued</b>				<b>1993-1991</b>			
<b>4-CYL. 2.4 L ENG. - Continued</b>				<b>V-6 3.8 L ENG.</b>			
Outlet (Driver Side) .....	A61080			"O" Ring From Cooler.....			②A63093
<b>V-6 2.5 L ENG.</b>				<b>LEBARON</b>			
Aux. Cooler Inlet Tube (Pass. Side) .....	A61040			<b>1995</b>			
Aux. Cooler Outlet Tube (Driver Side) .....	A61041			<b>V-6 3.0 L ENG.</b>			
Inlet (Upper) .....	B61038			Aux. Cooler Inlet Hose.....	∅A63000		
Outlet (Lower) .....	A61039			Aux. Cooler Outlet Hose.....	∅A63000		
<b>CONCORDE</b>				<b>1994-1993</b>			
<b>2004-2002</b>				<b>4-CYL. 2.5 L ENG.; V-6 3.0 L ENG.</b>			
<b>V-6 2.7 L ENG.</b>				Aux. Cooler Inlet Hose.....	∅A63000		
Inlet Fitting To Trans. (Lower) .....			A63035	Aux. Cooler Outlet Hose.....	∅A63000		
Inlet From Rad. (Upper).....	B61068			<b>1992-1991</b>			
Outlet Fitting To Trans. (Upper) .....			A63035	<b>4-CYL. 2.5 L ENG.</b>			
Outlet From Rad. (Lower).....	B61067			Aux. Cooler Inlet Hose.....	∅A63000		
<b>V-6 3.5 L ENG.</b>				Aux. Cooler Outlet Hose.....			
Inlet Fitting To Trans. (Upper).....			A63035	Aux. Cooler Inlet Hose.....	∅A63000		
Outlet Fitting To Trans. (Lower) .....			A63035	Aux. Cooler Outlet Hose.....	∅A63000		
<b>2001-1998</b>				<b>V-6 3.0 L ENG.</b>			
<b>V-6 2.7 L ENG.</b>				"O" Ring From Water Cooled			
Inlet Fitting To Trans. (Lower).....			A63035	Trans. Cooler .....			②A63093
Inlet From Rad. (Upper).....	B61068			Aux. Cooler Inlet Hose.....	∅A63000		
Outlet Fitting To Trans. (Upper) .....			A63035	Aux. Cooler Outlet Hose.....	∅A63000		
Outlet From Rad. (Lower).....	B61067			<b>1990</b>			
<b>V-6 3.2 L ENG.</b>				<b>4-CYL. 2.2 L ENG.; 4-CYL. 2.5 L ENG.; V-6 3.0 L ENG.</b>			
Inlet Fitting To Trans. (Upper).....			A63035	"O" Ring.....			②A63093
Outlet Fitting To Trans. (Lower) .....			A63035	Aux. Cooler Inlet Hose.....	∅A63000		
<b>1997</b>				Aux. Cooler Outlet Hose.....			
<b>V-6 3.5 L ENG.</b>				<b>1989-1986</b>			
Aux. Cooler Inlet (Pass. Side).....	A61072			<b>4-CYL. 2.2 L ENG.; 4-CYL. 2.5 L ENG.</b>			
Aux. Cooler Outlet (Driver Side).....	B61073			"O" Ring.....			②A63093
Inlet (Upper) .....	B61010			<b>LHS</b>			
Inlet Fitting To Trans. (Upper).....			A63035	<b>2001-1999</b>			
Outlet (Lower).....	B61011			<b>V-6 3.5 L ENG.</b>			
Outlet Fitting To Trans. (Lower) .....			A63035	Inlet Fitting To Trans. (Upper).....			A63035
<b>1996-1993</b>				Outlet Fitting To Trans. (Lower) .....			
<b>V-6 3.3 L ENG.; V-6 3.5 L ENG.</b>				<b>1997-1994</b>			
Aux. Cooler Inlet (Pass. Side).....	A61072			<b>V-6 3.5 L ENG.</b>			
Aux. Cooler Outlet (Driver Side).....	B61073			Aux. Cooler Inlet (Pass. Side).....	A61072		
Inlet (Upper) .....	B61010			Aux. Cooler Outlet (Driver Side).....	B61073		
Inlet Fitting To Trans. (Upper).....			A63035	Inlet (Upper) .....	B61010		
Outlet (Lower).....	B61011			Inlet Fitting To Trans. (Upper).....			A63035
Outlet Fitting To Trans. (Lower) .....			A63035	Outlet (Lower).....	B61011		
<b>FIFTH AVENUE</b>				Outlet Fitting To Trans. (Lower) .....			
<b>1989-1984</b>				<b>NEW YORKER</b>			
<b>V-8 5.2 L ENG.</b>				<b>1996-1994</b>			
Inlet .....		∅A63000		<b>V-6 3.5 L ENG.</b>			
Inlet Fitting To Trans.....			A63042	Aux. Cooler Inlet (Pass. Side).....	A61072		
Outlet .....		∅A63000		Aux. Cooler Outlet (Driver Side).....	B61073		
Outlet Fitting To Trans.....			A63042	Inlet (Upper) .....	B61010		
<b>GRAND VOYAGER</b>				Inlet Fitting To Trans. (Upper).....			
<b>2000</b>				Outlet (Lower).....			
<b>V-6 3.0 L ENG.; V-6 3.3 L ENG.</b>				Outlet Fitting To Trans. (Lower) .....			
Aux. Cooler Tube To Tube.....	A61007			<b>1993</b>			
Inlet (Upper) .....	A61102			<b>V-6 3.3 L ENG.; V-6 3.8 L ENG.</b>			
Outlet (Lower); W/A.C.....	A61006			"O" Ring From Cooler.....			②A63093
Outlet (Lower); W/O A.C.....	A61008						

② Two Required.  
③ Three Required.

④ Four Required.  
⑤ Five Required.

⑥ Six Required.  
⑦ Seven Required.

∅ Cut To Fit.  
● As Required.

See Pages 1 - 10 for Engine Oil Cooler Applications.

Product Section

Troubleshooting

EOC Applications

TOC Applications

Numerical Listing

Manufacturers' Part Numbers

End Fittings

Illustrations

## Transmission Oil Cooler Assemblies for Passenger Cars &amp; Light Trucks

Application	Assembly Number	Hoses & Tubes	Connectors & Fittings	Application	Assembly Number	Hoses & Tubes	Connectors & Fittings
<b>CHRYSLER - Continued</b>				<b>CHRYSLER - Continued</b>			
<b>NEW YORKER - Continued</b>				<b>SEBRING - Continued</b>			
<b>1992-1991</b>				<b>1996 - Continued</b>			
<b>V-6 3.3 L ENG.; V-6 3.8 L ENG.</b>				<b>V-6 2.5 L ENG.</b>			
"O" Ring; W/Water Cooled Trans.				Aux. Cooler Inlet Tube (Pass. Side).....			
Cooler.....				A61040			
<b>1988</b>				Aux. Cooler Outlet Tube (Driver Side).....			
<b>4-CYL. 2.2 L ENG.</b>				A61041			
"O" Ring From Water Cooled Trans. Cooler.....				B61038			
<b>1987-1986</b>				A61039			
<b>4-CYL. 2.2 L ENG.; 4-CYL. 2.5 L ENG.</b>				<b>1995</b>			
"O" Ring From Water Cooled Trans. Cooler.....				<b>4-CYL. 2.0 L ENG.</b>			
<b>SEBRING</b>				Aux. Cooler Inlet Tube (Pass. Side).....			
<b>2003-2001</b>				A61040			
<b>4-CYL. 2.4 L ENG.</b>				Aux. Cooler Outlet Tube (Driver Side).....			
Banjo Washers; W/SOHC Eng.....				A61041			
<b>V-6 3.0 L ENG.</b>				A61079			
Banjo Washers.....				A61080			
<b>2000</b>				<b>V-6 2.5 L ENG.</b>			
<b>V-6 2.5 L ENG.</b>				Aux. Cooler Inlet Tube (Pass. Side).....			
Rad. To Inlet Tube (Pass. Side); Coupe; W/O Calif. Emission System.....				A61040			
<b>1999</b>				Aux. Cooler Outlet Tube (Driver Side).....			
<b>4-CYL. 2.0 L ENG.</b>				A61041			
Rad. To Inlet Tube (Pass. Side); Convertible.....				B61038			
<b>1999</b>				A61039			
<b>4-CYL. 2.0 L ENG.</b>				<b>TC MASERATI</b>			
Rad. To Inlet Tube (Pass. Side); Coupe; W/O Calif. Emission System.....				<b>1991</b>			
<b>1999</b>				<b>V-6 3.0 L ENG.</b>			
<b>4-CYL. 2.4 L ENG.</b>				Cooler "O" Ring.....			
Inlet (Lower).....				A61079			
Outlet (Upper).....				A61080			
<b>V-6 2.5 L ENG.</b>				<b>1990</b>			
Inlet (Pass. Side); Convertible.....				<b>4-CYL. 2.2 L ENG.; V-6 3.0 L ENG.</b>			
Outlet (Driver Side); Convertible.....				Cooler "O" Ring.....			
Rad. To Inlet Tube (Pass. Side); Coupe; W/O Calif. Emission System.....				A61039			
<b>1998-1997</b>				<b>1989</b>			
<b>4-CYL. 2.4 L ENG.</b>				<b>4-CYL. 2.2 L ENG.</b>			
Inlet (Lower).....				Cooler "O" Ring.....			
Outlet (Upper).....				A61039			
<b>V-6 2.5 L ENG.</b>				<b>TOWN &amp; COUNTRY</b>			
Aux. Cooler Inlet Tube (Driver Side); Convertible.....				<b>1988-1986</b>			
Aux. Cooler Outlet Tube (Pass. Side); Convertible.....				<b>4-CYL. 2.2 L ENG.; 4-CYL. 2.5 L ENG.</b>			
Inlet (Driver Side); Convertible.....				"O" Ring; W/Water Cooled Trans.			
Outlet (Pass. Side); Convertible.....				Cooler.....			
<b>1996</b>				A61039			
<b>4-CYL. 2.0 L ENG.; 4-CYL. 2.4 L ENG.</b>				<b>TOWN &amp; COUNTRY VAN</b>			
Aux. Cooler Inlet Tube (Pass. Side).....				<b>2000</b>			
A61040				<b>V-6 3.3 L ENG.; V-6 3.8 L ENG.</b>			
Aux. Cooler Outlet Tube (Driver Side).....				Aux. Cooler Tube To Tube.....			
A61041				A61007			
Inlet (Pass. Side).....				Inlet (Upper); W/A.C.....			
A61079				A61102			
Outlet (Driver Side).....				Inlet (Upper); W/O A.C.....			
A61080				A61074			
<b>1996</b>				Outlet (Lower); W/A.C.....			
<b>4-CYL. 2.0 L ENG.; 4-CYL. 2.4 L ENG.</b>				A61006			
Aux. Cooler Inlet Tube (Pass. Side).....				A61008			
A61040				<b>1999</b>			
Aux. Cooler Outlet Tube (Pass. Side); Convertible.....				<b>V-6 3.3 L ENG.; V-6 3.8 L ENG.</b>			
A61041				Aux. Cooler Tube To Tube.....			
Inlet (Driver Side); Convertible.....				A61007			
A61038				Inlet (Upper); W/O Aux. Cooler.....			
Outlet (Pass. Side); Convertible.....				A61102			
A61039				Outlet (Lower); W/O Aux. Cooler....			
<b>1996</b>				A61006			
<b>4-CYL. 2.0 L ENG.; 4-CYL. 2.4 L ENG.</b>				<b>1998</b>			
Aux. Cooler Inlet Tube (Pass. Side).....				<b>V-6 3.3 L ENG.; V-6 3.8 L ENG.</b>			
A61040				Aux. Cooler Tube To Tube.....			
Aux. Cooler Outlet Tube (Driver Side).....				A61007			
A61041				Inlet (Upper); W/Front A.C.....			
Inlet (Pass. Side).....				A61102			
A61079				Inlet (Upper); W/H.D. Rad.....			
Outlet (Driver Side).....				A61082			
A61080				Inlet (Upper); W/Rear A.C.....			
				A61074			

② Two Required.  
③ Three Required.

④ Four Required.  
⑤ Five Required.

⑥ Six Required.  
⑦ Seven Required.

≠ Cut To Fit.  
● As Required.

See Pages 1 - 10 for Engine Oil Cooler Applications.

# Transmission Oil Cooler Assemblies for Passenger Cars & Light Trucks

Application	Assembly Number	Hoses & Tubes	Connectors & Fittings	Application	Assembly Number	Hoses & Tubes	Connectors & Fittings
<b>CHRYSLER - Continued</b>				<b>CHRYSLER - Continued</b>			
<b>TOWN &amp; COUNTRY VAN - Continued</b>				<b>TOWN &amp; COUNTRY VAN - Continued</b>			
<b>1998 - Continued</b>				<b>1993 - Continued</b>			
<b>V-6 3.3 L ENG.; V-6 3.8 L ENG. - Continued</b>				<b>V-6 3.3 L ENG. - Continued</b>			
Outlet (Lower); W/Front A.C.....	A61006			Outlet (Lower); W/Water Cooled Trans. Cooler; W/O A.C.....	A61090		
Outlet (Lower); W/H.D. Rad.....	A61082			Outlet Tube; W/Air Cooled Trans. Cooler.....	B61064		
Outlet (Lower); W/Rear A.C.....	A61008						
Rad. Oil Cooler Inlet (Lower).....	B61065						
Rad. Oil Cooler Supply (Upper).....	B61066						
<b>1997</b>				<b>1992</b>			
<b>V-6 3.3 L ENG.</b>				<b>V-6 3.3 L ENG.</b>			
Aux. Cooler Tube To Tube.....	A61007			"O" Ring; W/Water Cooled Trans. Cooler.....			②A63093
Inlet (Upper); W/4-Speed Trans. ....	A61102			Inlet Hose; W/Air Cooled Trans. Cooler; W/AWD.....		⊗A63000	
Inlet (Upper); W/H.D. Rad.; W/O Trlr. Tow. Pkg. ....	A61096			Outlet Hose; W/Air Cooled Trans. Cooler; W/AWD.....		⊗A63000	
Inlet (Upper); W/Rear A.C.; W/4-Speed Trans. ....	A61074						
Outlet (Lower); W/4-Speed Trans....	A61006						
Outlet (Lower); W/H.D. Rad.; W/O Trlr. Tow. Pkg. ....	A61095						
Outlet (Lower); W/Rear A.C.; W/4-Speed Trans. ....	A61008						
Rad. Oil Cooler Inlet (Lower); W/Trlr. Tow. Pkg. ....	B61065						
Rad. Oil Cooler Supply (Upper); W/Trlr. Tow. Pkg. ....	B61066						
<b>V-6 3.8 L ENG.</b>				<b>1991-1990</b>			
Aux. Cooler Tube To Tube.....	A61007			<b>V-6 3.3 L ENG.</b>			
Inlet (Upper); W/4-Speed Trans. ....	A61102			"O" Ring; W/Water Cooled Trans. Cooler.....			②A63093
Outlet (Lower); W/4-Speed Trans....	A61006						
Rad. Oil Cooler Inlet (Lower); W/Trlr. Tow. Pkg. ....	B61065						
Rad. Oil Cooler Supply (Upper); W/Trlr. Tow. Pkg. ....	B61066						
<b>1996</b>				<b>VOYAGER</b>			
<b>V-6 3.3 L ENG.; V-6 3.8 L ENG.</b>				<b>2003</b>			
Rad. Oil Cooler Inlet (Lower); W/Trlr. Tow. Pkg. ....	B61065			<b>4-CYL. 2.4 L ENG.; V-6 3.3 L ENG.</b>			
Rad. Oil Cooler Supply (Upper); W/Trlr. Tow. Pkg. ....	B61066			Aux. Cooler Inlet Hose (Upper).....		⊗A63000	
				Aux. Cooler Outlet Hose (Lower)....		⊗A63000	
<b>1995-1994</b>				<b>2002-2001</b>			
<b>V-6 3.8 L ENG.</b>				<b>V-6 3.3 L ENG.</b>			
"O" Ring; W/Water Cooled Trans. Cooler.....			②A63093	Aux. Cooler Inlet Hose (Upper).....		⊗A63000	
Inlet (Upper); W/Water Cooled Trans. Cooler; W/A.C.....	A61094			Aux. Cooler Outlet Hose (Lower)....		⊗A63000	
Inlet (Upper); W/Water Cooled Trans. Cooler; W/O A.C. ....	A61091						
Inlet Hose; W/Air Cooled Trans. Cooler.....	A61063						
Outlet (Lower); W/Water Cooled Trans. Cooler; W/A.C.....	A61092						
Outlet (Lower); W/Water Cooled Trans. Cooler; W/O A.C. ....	A61090						
Outlet Tube; W/Air Cooled Trans. Cooler.....	B61064						
<b>1993</b>				<b>2000</b>			
<b>V-6 3.3 L ENG.</b>				<b>V-6 3.0 L ENG.; V-6 3.3 L ENG.</b>			
"O" Ring; W/Water Cooled Trans. Cooler.....			②A63093	Aux. Cooler Tube To Tube.....	A61007		
Inlet (Upper); W/Water Cooled Trans. Cooler; W/A.C.....	A61094			Inlet (Upper).....	A61102		
Inlet (Upper); W/Water Cooled Trans. Cooler; W/O A.C. ....	A61091			Outlet (Lower); W/A.C.....	A61006		
Inlet Hose; W/Air Cooled Trans. Cooler.....	A61063			Outlet (Lower); W/O A.C.....	A61008		
Outlet (Lower); W/Water Cooled Trans. Cooler; W/A.C.....	A61092						
Outlet (Lower); W/Water Cooled Trans. Cooler; W/O A.C. ....	A61090						
Outlet Tube; W/Air Cooled Trans. Cooler.....	B61064						
<b>2004-1999</b>				<b>300M</b>			
<b>V-6 3.5 L ENG.</b>				<b>2004-1999</b>			
Inlet Fitting To Trans. (Upper).....	A63035			<b>V-6 3.5 L ENG.</b>			
Outlet Fitting To Trans. (Lower)....	A63035			Inlet Fitting To Trans. (Upper).....			A63035
				Outlet Fitting To Trans. (Lower)....			A63035
<b>DODGE</b>				<b>DODGE</b>			
<b>ARIES</b>				<b>ARIES</b>			
<b>1987-1986</b>				<b>1987-1986</b>			
<b>4-CYL. 2.2 L ENG.; 4-CYL. 2.5 L ENG.</b>				<b>4-CYL. 2.2 L ENG.; 4-CYL. 2.5 L ENG.</b>			
"O" Ring From Aux. Cooler.....			②A63093	"O" Ring From Aux. Cooler.....			②A63093
<b>ARIES AMERICA</b>				<b>ARIES AMERICA</b>			
<b>1989-1988</b>				<b>1989-1988</b>			
<b>4-CYL. 2.2 L ENG.; 4-CYL. 2.5 L ENG.</b>				<b>4-CYL. 2.2 L ENG.; 4-CYL. 2.5 L ENG.</b>			
"O" Ring From Aux. Cooler.....			②A63093	"O" Ring From Aux. Cooler.....			②A63093
<b>AVENGER</b>				<b>AVENGER</b>			
<b>2000</b>				<b>2000</b>			
<b>V-6 2.5 L ENG.</b>				<b>V-6 2.5 L ENG.</b>			
Rad. To Inlet Tube (Pass. Side); W/O Calif. Emission System.....			⊗A63000	Rad. To Inlet Tube (Pass. Side); W/O Calif. Emission System.....			⊗A63000

② Two Required.  
③ Three Required.

④ Four Required.  
⑤ Five Required.

⑥ Six Required.  
⑦ Seven Required.

⊗ Cut To Fit.  
● As Required.

See Pages 1 - 10 for Engine Oil Cooler Applications.

Product Section

Troubleshooting

EOC Applications

TOC Applications

Numerical Listing

Manufacturers' Part Numbers

End Fittings

Illustrations



# Transmission Oil Cooler Assemblies for Passenger Cars & Light Trucks

Application	Assembly Number	Hoses & Tubes	Connectors & Fittings	Application	Assembly Number	Hoses & Tubes	Connectors & Fittings
<b>DODGE - Continued</b>				<b>DODGE - Continued</b>			
<b>B SERIES VAN - Continued</b>				<b>CARAVAN - Continued</b>			
<b>1993-1990 - Continued</b>				<b>1997</b>			
<b>V-6 3.9 L ENG.; V-8 5.2 L ENG.; V-8 5.9 L ENG. - Continued</b>				<b>4-CYL. 2.4 L ENG.</b>			
Outlet Tube.....		∅-A63005		Inlet (Upper); W/4-Speed Trans. ....	A61074		
				Outlet (Lower); W/4-Speed Trans....	A61008		
<b>1989-1988</b>				<b>V-6 3.0 L ENG.</b>			
<b>V-6 3.9 L ENG.; V-8 5.2 L ENG.; V-8 5.9 L ENG.</b>				Inlet (Upper); W/H.D. Rad. ....			
Inlet Fitting To Trans.....			A63042	Outlet (Lower); W/H.D. Rad.....	A61095		
Inlet Hose .....		∅-A63004		<b>V-6 3.3 L ENG.; V-6 3.8 L ENG.</b>			
Inlet Tube .....		∅-A63000		Aux. Cooler Tube To Tube.....	A61007		
Outlet Fitting To Trans.....			A63042	Inlet (Upper); W/4-Speed Trans. ....	A61102		
Outlet Hose .....		∅-A63004		Inlet (Upper); W/H.D. Rad.; W/O			
Outlet Tube.....		∅-A63000		Trlr. Tow. Pkg. ....	A61096		
<b>1987-1984</b>				Inlet (Upper); W/Rear A.C. ....			
<b>V-8 5.2 L ENG.; V-8 5.9 L ENG.</b>				Outlet (Lower); W/4-Speed Trans....			
Inlet Fitting To Trans.....			A63042	Outlet (Lower); W/H.D. Rad.; W/O			
Inlet Hose .....		∅-A63004		Trlr. Tow. Pkg. ....	A61095		
Inlet Tube .....		∅-A63000		Outlet (Lower); W/Rear A.C.....	A61008		
Outlet Fitting To Trans.....			A63042	Rad. Oil Cooler Inlet (Lower);			
Outlet Hose .....		∅-A63004		W/Trlr. Tow. Pkg.....	B61065		
Outlet Tube.....		∅-A63000		Rad. Oil Cooler Supply (Upper);			
<b>CARAVAN</b>				W/Trlr. Tow. Pkg.....			
<b>2002-2001</b>				B61066			
<b>V-6 3.3 L ENG.</b>				<b>1996</b>			
Aux. Cooler Inlet (Upper).....		∅-A63000		<b>4-CYL. 2.4 L ENG.</b>			
Aux. Cooler Outlet (Lower).....		∅-A63000		Inlet (Upper); W/3-Speed Trans. ....			
<b>2000</b>				Outlet (Lower); W/3-Speed Trans....			
<b>V-6 3.0 L ENG.; V-6 3.3 L ENG.</b>				A61084			
Aux. Cooler Tube To Tube.....	A61007			Outlet (Lower); W/3-Speed Trans....			
Inlet (Upper) .....	A61102			A61083			
Outlet (Lower); W/A.C.....	A61006			<b>V-6 3.0 L ENG.</b>			
Outlet (Lower); W/O A.C.....	A61008			Inlet (Upper) .....			
<b>1999</b>				Outlet (Lower).....			
<b>V-6 3.0 L ENG.; V-6 3.3 L ENG.; V-6 3.8 L ENG.</b>				A61084			
Aux. Cooler Tube To Tube.....	A61007			A61083			
Inlet (Upper) .....	A61102			<b>V-6 3.3 L ENG.; V-6 3.8 L ENG.</b>			
Outlet (Lower).....	A61006			Rad. Oil Cooler Inlet (Upper);			
<b>1998</b>				W/Trlr. Tow. Pkg.....			
<b>V-6 3.0 L ENG.</b>				B61066			
Inlet (Upper); W/4-Speed Trans.;				W/Trlr. Tow. Pkg.....			
W/Front A.C. ....	A61102			B61065			
Inlet (Upper); W/4-Speed Trans.;				W/Trlr. Tow. Pkg.....			
W/O A.C.....	A61074			B61066			
Inlet (Upper); W/4-Speed Trans.;				<b>1995-1994</b>			
W/Rear A.C. ....	A61096			<b>4-CYL. 2.5 L ENG.</b>			
Outlet (Lower); W/4-Speed Trans.;				"O" Ring; W/Water Cooled Trans.			
W/Front A.C. ....	A61006			Cooler.....			
Outlet (Lower); W/4-Speed Trans.;				②A63093			
W/O A.C.....	A61008			Inlet (Upper); W/Water Cooled			
Outlet (Lower); W/4-Speed Trans.;				Trans. Cooler .....			
W/Rear A.C. ....	A61095			A61061			
Rad. Oil Cooler Inlet (Lower);				Inlet Hose; W/Air Cooled Trans.			
W/3-Speed Trans.....	B61065			Cooler .....			
Rad. Oil Cooler Supply (Upper);				A61063			
W/3-Speed Trans.....	B61066			Outlet (Lower); W/Water Cooled			
<b>V-6 3.3 L ENG.; V-6 3.8 L ENG.</b>				Trans. Cooler .....			
Aux. Cooler Tube To Tube.....	A61007			A61062			
Inlet (Upper); W/Front A.C.....	A61102			<b>V-6 3.0 L ENG.</b>			
Inlet (Upper); W/H.D. Rad. ....	A61082			"O" Ring; W/Water Cooled			
Inlet (Upper); W/Rear A.C. ....	A61074			Cooler.....			
Outlet (Lower); W/Front A.C.....	A61006			A63093			
Outlet (Lower); W/H.D. Rad. ....	A61082			Inlet (Upper); W/Water Cooled			
Outlet (Lower); W/Rear A.C.....	A61008			Trans. Cooler; W/3-Speed			
Rad. Oil Cooler Inlet (Lower).....	B61065			Trans.; W/O Rear A.C. ....			
Rad. Oil Cooler Supply (Upper) .....	B61066			A61062			
				Inlet (Upper); W/Water Cooled			
				Trans. Cooler; W/3-Speed			
				Trans.; W/Rear A.C. ....			
				A61089			
				Inlet (Upper); W/Water Cooled			
				Trans. Cooler; W/4-Speed			
				Trans.; W/A.C.....			
				A61093			
				Inlet (Upper); W/Water Cooled			
				Trans. Cooler; W/4-Speed			
				Trans.; W/O A.C. ....			
				A61087			
				Inlet Hose; W/Air Cooled Trans.			
				Cooler .....			
				A61063			
				Outlet (Lower); W/Water Cooled			
				Trans. Cooler; W/3-Speed			
				Trans.; W/O Rear A.C. ....			
				A61061			

② Two Required.  
③ Three Required.

④ Four Required.  
⑤ Five Required.

⑥ Six Required.  
⑦ Seven Required.

∅ Cut To Fit.  
● As Required.

See Pages 1 - 10 for Engine Oil Cooler Applications.

## Transmission Oil Cooler Assemblies for Passenger Cars &amp; Light Trucks

Application	Assembly Number	Hoses & Tubes	Connectors & Fittings	Application	Assembly Number	Hoses & Tubes	Connectors & Fittings
<b>DODGE - Continued</b>				<b>DODGE - Continued</b>			
<b>CARAVAN - Continued</b>				<b>CARAVAN - Continued</b>			
<b>1995-1994 - Continued</b>				<b>1992 - Continued</b>			
<b>V-6 3.0 L ENG. - Continued</b>				<b>V-6 3.3 L ENG.</b>			
Outlet (Lower); W/Water Cooled Trans. Cooler; W/3-Speed Trans.; W/Rear A.C. ....	A61088			"O" Ring; W/Water Cooled Trans. Cooler.....			②A63093
Outlet (Lower); W/Water Cooled Trans. Cooler; W/4-Speed Trans.; W/A.C.....	A61092			Inlet Hose; W/Air Cooled Trans. Cooler; W/AWD.....		≠A63000	
Outlet (Lower); W/Water Cooled Trans. Cooler; W/4-Speed Trans.; W/O A.C. ....	A61085			Outlet Hose; W/Air Cooled Trans. Cooler; W/AWD.....		≠A63000	
Outlet Tube; W/Air Cooled Trans. Cooler.....	B61064			<b>1991</b>			
<b>V-6 3.3 L ENG.</b>				<b>4-CYL. 2.5 L ENG.</b>			
"O" Ring; W/Water Cooled Trans. Cooler.....			②A63093	"O" Ring; W/Water Cooled Trans. Cooler.....			②A63093
Inlet (Upper); W/Water Cooled Trans. Cooler; W/A.C.....	A61094			<b>V-6 3.0 L ENG.; V-6 3.3 L ENG.</b>			
Inlet (Upper); W/Water Cooled Trans. Cooler; W/O A.C. ....	A61091			"O" Ring; W/Water Cooled Trans. Cooler.....			②A63093
Inlet Hose; W/Air Cooled Trans. Cooler.....	A61063			Inlet Hose; W/Air Cooled Trans. Cooler; W/AWD.....		≠A63000	
Outlet (Lower); W/Water Cooled Trans. Cooler; W/A.C.....	A61092			Outlet Hose; W/Air Cooled Trans. Cooler; W/AWD.....		≠A63000	
Outlet (Lower); W/Water Cooled Trans. Cooler; W/O A.C. ....	A61090			<b>1990</b>			
Outlet Tube; W/Air Cooled Trans. Cooler.....	B61064			<b>4-CYL. 2.5 L ENG.; V-6 3.0 L ENG.; V-6 3.3 L ENG.</b>			
<b>1993</b>				<b>4-CYL. 2.5 L ENG.; V-6 3.0 L ENG.; V-6 3.3 L ENG.</b>			
<b>4-CYL. 2.5 L ENG.</b>				<b>"O" Ring; W/Water Cooled Trans.</b>			
"O" Ring; W/Water Cooled Trans. Cooler.....			②A63093	<b>Cooler.....</b>			
Inlet (Upper); W/Water Cooled Trans. Cooler.....	A61061			<b>1989-1988</b>			
Inlet Hose; W/Air Cooled Trans. Cooler.....	A61063			<b>4-CYL. 2.5 L ENG.; V-6 3.0 L ENG.</b>			
Outlet (Lower); W/Water Cooled Trans. Cooler.....	A61062			<b>"O" Ring; W/Water Cooled Trans.</b>			
Outlet Tube; W/Air Cooled Trans. Cooler.....	B61064			<b>Cooler.....</b>			
<b>V-6 3.0 L ENG.</b>				<b>1987-1986</b>			
"O" Ring; W/Water Cooled Trans. Cooler.....			②A63093	<b>4-CYL. 2.2 L ENG.</b>			
Inlet (Upper); W/Water Cooled Trans. Cooler; W/O Rear A.C. ....	A61086			<b>"O" Ring; W/Water Cooled Trans.</b>			
Inlet (Upper); W/Water Cooled Trans. Cooler; W/Rear A.C. ....	A61087			<b>Cooler.....</b>			
Inlet Hose; W/Air Cooled Trans. Cooler.....	A61063			<b>②A63093</b>			
Outlet (Lower); W/Water Cooled Trans. Cooler.....	A61085			<b>D &amp; W SERIES PICKUP</b>			
Outlet Tube; W/Air Cooled Trans. Cooler.....	B61064			<b>1993-1990</b>			
<b>V-6 3.3 L ENG.</b>				<b>6-CYL. 5.9 L DIESEL ENG.</b>			
"O" Ring; W/Water Cooled Trans. Cooler.....			②A63093	Hose From Oil Cooler To Tube (Upper).....			
Inlet (Upper); W/Water Cooled Trans. Cooler; W/Rear A.C. ....	A61087			Inlet Fitting To Trans.....			
Inlet (Upper); W/Water Cooled Trans. Cooler; W/Rear A.C. ....	A61087			Oil Cooler Hose Elbows.....			
Inlet Hose; W/Air Cooled Trans. Cooler.....	A61063			Oil Cooler Inlet Tube To Trans. (Front); W/Sensor.....			
Outlet (Lower); W/Water Cooled Trans. Cooler.....	A61085			Outlet Fitting To Trans.....			
Outlet Tube; W/Air Cooled Trans. Cooler.....	B61064			<b>V-6 3.9 L ENG.; V-8 5.2 L ENG.; V-8 5.9 L ENG.</b>			
<b>V-6 3.3 L ENG.</b>				<b>Inlet Fitting To Trans.....</b>			
"O" Ring; W/Water Cooled Trans. Cooler.....			②A63093	Inlet Hose (Pass. Side).....			
Inlet (Upper); W/Water Cooled Trans. Cooler.....	A61091			Inlet Tube (Pass. Side).....			
Inlet Hose; W/Air Cooled Trans. Cooler.....	A61063			Outlet Fitting To Trans.....			
Outlet (Lower); W/Water Cooled Trans. Cooler.....	A61090			Outlet Hose (Driver Side).....			
Outlet Tube; W/Air Cooled Trans. Cooler.....	B61064			Outlet Tube (Driver Side).....			
<b>1992</b>				<b>1989</b>			
<b>4-CYL. 2.5 L ENG.; V-6 3.0 L ENG.</b>				<b>6-CYL. 5.9 L DIESEL ENG.</b>			
"O" Ring; W/Water Cooled Trans. Cooler.....			②A63093	Hose From Oil Cooler To Tube (Upper).....			
<b>② Two Required.</b>				Inlet Fitting To Trans.....			
<b>③ Three Required.</b>				Oil Cooler Hose Elbows.....			
<b>④ Four Required.</b>				Oil Cooler Inlet Tube To Trans. (Front); W/Sensor.....			
<b>⑤ Five Required.</b>				Outlet Fitting To Trans.....			
<b>⑥ Six Required.</b>				<b>V-6 3.9 L ENG.; V-8 5.2 L ENG.; V-8 5.9 L ENG.</b>			
<b>⑦ Seven Required.</b>				<b>Inlet Fitting To Trans.....</b>			
<b>≠ Cut To Fit.</b>				<b>As Required.</b>			

② Two Required.  
③ Three Required.

④ Four Required.  
⑤ Five Required.

⑥ Six Required.  
⑦ Seven Required.

≠ Cut To Fit.  
● As Required.

See Pages 1 - 10 for Engine Oil Cooler Applications.





## Transmission Oil Cooler Assemblies for Passenger Cars &amp; Light Trucks

Application	Assembly Number	Hoses & Tubes	Connectors & Fittings	Application	Assembly Number	Hoses & Tubes	Connectors & Fittings
<b>DODGE - Continued</b>				<b>DODGE - Continued</b>			
<b>DAKOTA - Continued</b>				<b>DAYTONA - Continued</b>			
<b>1996-1994 - Continued</b>				<b>1991</b>			
<b>V-6 3.9 L ENG. - Continued</b>				<b>4-CYL. 2.5 L ENG.; V-6 3.0 L ENG.</b>			
Rad. Outlet Tube To Aux. Cooler (Upper).....	B61116			"O" Ring; W/Water Cooled Trans. Cooler.....			ⓄA63093
Rad. Supply Tube To Aux. Cooler (Lower).....	A61115			Aux. Cooler Inlet.....	≠A63000		
<b>V-8 5.2 L ENG.</b>				Aux. Cooler Outlet.....	≠A63000		
Aux. Cooler Hose.....		≠A63001		<b>1990</b>			
Inlet Fitting To Trans.; W/Flared Tube.....			A63035	<b>4-CYL. 2.2 L ENG.; 4-CYL. 2.5 L ENG.; V-6 3.0 L ENG.</b>			
Inlet Fitting To Trans.; W/Quick Connect Tube.....			A63032	"O" Ring.....			ⓄA63093
Inlet Hose From Rad. (Pass. Side); W/O Snow Plow Pkg. ....	A61136			Aux. Cooler Inlet.....	≠A63000		
Inlet Tube To Trans. (Pass. Side); W/O Snow Plow Pkg. ....	B61135			Aux. Cooler Outlet.....	≠A63000		
Outlet (Driver Side).....	B61132			<b>1989-1988</b>			
Outlet Fitting To Trans.; W/Flared Tube.....			A63035	<b>4-CYL. 2.2 L ENG.; 4-CYL. 2.5 L ENG.</b>			
Outlet Fitting To Trans.; W/Quick Connect Tube.....			A63032	"O" Ring From Aux. Cooler.....			ⓄA63093
Rad. Outlet Tube To Aux. Cooler (Upper).....	B61116			<b>1987-1986</b>			
Rad. Supply Tube To Aux. Cooler (Lower).....	A61115			<b>4-CYL. 2.2 L ENG.; 4-CYL. 2.5 L ENG.</b>			
<b>1993-1990</b>				"O" Ring; W/Water Cooled Trans. Cooler.....			ⓄA63093
<b>V-6 3.9 L ENG.; V-8 5.2 L ENG.</b>				<b>DIPLOMAT</b>			
Inlet Fitting To Trans.....			A63035	<b>1989-1984</b>			
Inlet Hose (Pass. Side).....		≠A63001		<b>V-8 5.2 L ENG.</b>			
Inlet Tube (Pass. Side).....		≠A63005		Inlet.....	≠A63000		A63042
Outlet Fitting To Trans.....			A63035	Inlet Fitting To Trans.....			A63042
Outlet Hose (Driver Side).....		≠A63001		Outlet.....	≠A63000		
Outlet Tube (Driver Side).....		≠A63005		Outlet Fitting To Trans.....			A63042
<b>1989</b>				<b>DURANGO</b>			
<b>V-6 3.9 L ENG.; V-8 5.2 L ENG.</b>				<b>2003-2001</b>			
"O" Ring; W/Aux. Cooler.....			ⓄA63093	<b>V-8 5.9 L ENG.</b>			
Inlet Fitting To Trans.....			A63042	Inlet Fitting To Trans.....			A63035
Inlet Hose (Pass. Side).....		≠A63000		Inlet Hose From Rad. (Pass. Side).....	A61162		
Inlet Tube (Pass. Side).....		≠A63004		Inlet Tube To Trans. (Front).....	B61203		
Outlet Fitting To Trans.....			A63042	Outlet Fitting To Trans.....			A63035
Outlet Hose (Driver Side).....		≠A63000		Outlet From Rad. (Driver Side).....	B61164		
Outlet Tube (Driver Side).....		≠A63004		<b>2000</b>			
<b>1988-1987</b>				<b>V-8 5.2 L ENG.</b>			
<b>V-6 3.9 L ENG.</b>				Inlet Fitting To Trans.....			
"O" Ring; W/Aux. Cooler.....			ⓄA63093	Inlet Hose From Rad. (Pass. Side).....	A61162		A63035
Inlet Fitting To Trans.....			A63042	Inlet Tube To Trans. (Pass. Side)...	B61200		
Inlet Hose (Pass. Side).....		≠A63000		Outlet Fitting To Trans.....			A63035
Inlet Tube (Pass. Side).....		≠A63004		<b>V-8 5.9 L ENG.</b>			
Outlet Fitting To Trans.....			A63042	Inlet Fitting To Trans.....			
Outlet Hose (Driver Side).....		≠A63000		Inlet Hose From Rad. (Pass. Side).....			
Outlet Tube (Driver Side).....		≠A63004		Inlet Tube To Trans. (Pass. Side)...			
<b>DAYTONA</b>				Outlet Fitting To Trans.....			
<b>1993</b>				Outlet From Rad. (Driver Side).....			
<b>4-CYL. 2.5 L ENG.; V-6 3.0 L ENG.</b>				<b>1999</b>			
Aux. Cooler Inlet.....		≠A63000		<b>V-6 3.9 L ENG.</b>			
Aux. Cooler Outlet.....		≠A63000		Inlet Fitting To Trans.....			
<b>1992</b>				Inlet Hose From Rad. (Pass. Side); W/2WD.....			
<b>4-CYL. 2.2 L ENG.; 4-CYL. 2.5 L ENG.; V-6 3.0 L ENG.</b>				Inlet Hose From Rad. (Pass. Side); W/4WD.....			
"O" Ring; W/Water Cooled Trans. Cooler.....			ⓄA63093	Inlet Tube To Trans. (Pass. Side); W/2WD.....			
Aux. Cooler Inlet.....		≠A63000		Inlet Tube To Trans. (Pass. Side); W/4WD.....			
Aux. Cooler Outlet.....		≠A63000		Outlet (Driver Side); W/2WD.....			
				Outlet (Driver Side); W/4WD.....			
				Outlet Fitting To Trans.....			

Ⓞ Two Required.  
Ⓜ Three Required.

Ⓠ Four Required.  
Ⓡ Five Required.

Ⓢ Six Required.  
Ⓣ Seven Required.

≠ Cut To Fit.  
● As Required.

See Pages 1 - 10 for Engine Oil Cooler Applications.

# Transmission Oil Cooler Assemblies for Passenger Cars & Light Trucks

Application	Assembly Number	Hoses & Tubes	Connectors & Fittings	Application	Assembly Number	Hoses & Tubes	Connectors & Fittings
<b>DODGE - Continued</b>				<b>DODGE - Continued</b>			
<b>DURANGO - Continued</b>				<b>GRAND CARAVAN</b>			
<b>1999 - Continued</b>				<b>2002-2001</b>			
<b>V-8 5.2 L ENG.</b>				<b>V-6 3.3 L ENG.; V-6 3.8 L ENG.</b>			
Inlet Fitting To Trans.....			A63035	Aux. Cooler Inlet (Upper).....		④A63000	
Inlet Hose From Rad. (Pass. Side); W/2WD .....	A61162			Aux. Cooler Outlet (Lower).....		④A63000	
Inlet Hose From Rad. (Pass. Side); W/4WD .....	A61152			<b>2000</b>			
Inlet Tube To Trans. (Pass. Side); W/2WD .....	B61200			<b>V-6 3.0 L ENG.; V-6 3.3 L ENG.; V-6 3.8 L ENG.</b>			
Inlet Tube To Trans. (Pass. Side); W/4WD .....	B61166			Aux. Cooler Tube To Tube.....	A61007		
Outlet Fitting To Trans.....			A63035	Inlet (Upper) .....	A61102		
Outlet From Rad. (Driver Side); W/2WD .....	B61153			Outlet (Lower); W/A.C.....	A61006		
Outlet From Rad. (Driver Side); W/4WD .....	B61167			Outlet (Lower); W/O A.C.....	A61008		
Rad. Outlet Tube To Aux. Cooler (Upper) .....	B61104			<b>1999</b>			
Rad. Supply Tube To Aux. Cooler (Lower) .....	A61131			<b>V-6 3.0 L ENG.; V-6 3.3 L ENG.; V-6 3.8 L ENG.</b>			
<b>V-8 5.9 L ENG.</b>				<b>V-6 3.0 L ENG.</b>			
Inlet Fitting To Trans.....			A63035	Aux. Cooler Tube To Tube.....	A61007		
Inlet Hose From Rad. (Pass. Side); W/2WD .....	A61162			Inlet (Upper) .....	A61102		
Inlet Hose From Rad. (Pass. Side); W/4WD .....	A61152			Outlet (Lower).....	A61006		
Inlet Tube To Trans. (Pass. Side); W/2WD .....	B61161			<b>1998</b>			
Inlet Tube To Trans. (Pass. Side); W/4WD .....	B61166			<b>V-6 3.0 L ENG.</b>			
Outlet Fitting To Trans.....			A63035	Inlet (Upper); W/4-Speed Trans.; W/Front A.C. ....	A61102		
Outlet From Rad. (Driver Side); W/2WD .....	B61164			Inlet (Upper); W/4-Speed Trans.; W/O A.C. ....	A61074		
Outlet From Rad. (Driver Side); W/4WD .....	B61167			Inlet (Upper); W/4-Speed Trans.; W/Rear A.C. ....	A61096		
Rad. Outlet Tube To Aux. Cooler (Upper) .....	B61104			Outlet (Lower); W/4-Speed Trans.; W/Front A.C. ....	A61006		
Rad. Supply Tube To Aux. Cooler (Lower) .....	A61131			Outlet (Lower); W/4-Speed Trans.; W/O A.C. ....	A61008		
<b>1998</b>				Outlet (Lower); W/4-Speed Trans.; W/Rear A.C. ....			
<b>V-6 3.9 L ENG.</b>				Rad. Oil Cooler Inlet (Lower); W/3-Speed Trans. ....			
Inlet Fitting To Trans.....			A63035	Rad. Oil Cooler Supply (Upper); W/3-Speed Trans. ....	B61066		
Inlet Hose From Rad. (Pass. Side).....	A61152			<b>V-6 3.3 L ENG.; V-6 3.8 L ENG.</b>			
Inlet Tube To Trans. (Pass. Side).....	B61166			Aux. Cooler Tube To Tube.....	A61007		
Outlet (Driver Side) .....	B61167			Inlet (Upper); W/Front A.C. ....	A61102		
Outlet Fitting To Trans.....			A63035	Inlet (Upper); W/H.D. Rad. ....	A61082		
<b>V-8 5.2 L ENG.; V-8 5.9 L ENG.</b>				Inlet (Upper); W/Rear A.C. ....			
Inlet Fitting To Trans.....			A63035	Outlet (Lower); W/Front A.C. ....	A61006		
Inlet Hose From Rad. (Pass. Side).....	A61152			Outlet (Lower); W/H.D. Rad. ....	A61082		
Inlet Tube To Trans. (Pass. Side).....	B61166			Outlet (Lower); W/Rear A.C. ....	A61008		
Outlet (Driver Side) .....	B61167			Rad. Oil Cooler Inlet (Lower).....	B61065		
Outlet Fitting To Trans.....			A63035	Rad. Oil Cooler Supply (Upper) ....	B61066		
<b>V-8 5.2 L ENG.; V-8 5.9 L ENG.</b>				<b>1997</b>			
Inlet Fitting To Trans.....			A63035	<b>4-CYL. 2.4 L ENG.</b>			
Inlet Hose From Rad. (Pass. Side).....	A61152			<b>Inlet (Upper); W/4-Speed Trans. ....</b>			
Inlet Tube To Trans. (Pass. Side).....	B61166			<b>Outlet (Lower); W/4-Speed Trans....</b>			
Outlet (Driver Side) .....	B61167			<b>V-6 3.0 L ENG.</b>			
Outlet Fitting To Trans.....			A63035	<b>Inlet (Upper); W/H.D. Rad. ....</b>			
Rad. Outlet Tube To Aux. Cooler (Upper) .....	B61104			<b>Outlet (Lower); W/H.D. Rad. ....</b>			
Rad. Supply Tube To Aux. Cooler (Lower) .....	A61131			<b>V-6 3.3 L ENG.; V-6 3.8 L ENG.</b>			
<b>DYNASTY</b>				<b>Aux. Cooler Tube To Tube.....</b>			
<b>1993</b>				<b>Inlet (Upper); W/4-Speed Trans. ....</b>			
<b>V-6 3.0 L ENG.; V-6 3.3 L ENG.</b>				<b>Outlet (Lower); W/4-Speed Trans....</b>			
"O" Ring From Cooler.....			②A63093	<b>Inlet (Upper); W/H.D. Rad.; W/O Trlr. Tow. Pkg. ....</b>			
<b>1992-1991</b>				<b>Inlet (Upper); W/Rear A.C. ....</b>			
<b>4-CYL. 2.5 L ENG.; V-6 3.0 L ENG.; V-6 3.3 L ENG.</b>				<b>Outlet (Lower); W/4-Speed Trans....</b>			
"O" Ring; W/Water Cooled Trans. Cooler .....			②A63093	<b>Outlet (Lower); W/H.D. Rad.; W/O Trlr. Tow. Pkg. ....</b>			
				<b>Rad. Oil Cooler Inlet (Lower); W/Trlr. Tow. Pkg. ....</b>			
				<b>Rad. Oil Cooler Supply (Upper); W/Trlr. Tow. Pkg. ....</b>			

② Two Required.  
③ Three Required.

④ Four Required.  
⑤ Five Required.

⑥ Six Required.  
⑦ Seven Required.

✂ Cut To Fit.  
● As Required.

See Pages 1 - 10 for Engine Oil Cooler Applications.

## Transmission Oil Cooler Assemblies for Passenger Cars &amp; Light Trucks

Application	Assembly Number	Hoses & Tubes	Connectors & Fittings	Application	Assembly Number	Hoses & Tubes	Connectors & Fittings
<b>DODGE - Continued</b>				<b>DODGE - Continued</b>			
<b>GRAND CARAVAN - Continued</b>				<b>GRAND CARAVAN - Continued</b>			
<b>1996</b>				<b>1994 - Continued</b>			
<b>4-CYL. 2.4 L ENG.</b>				<b>V-6 3.0 L ENG. - Continued</b>			
Inlet (Upper); W/3-Speed Trans. ....	A61084			Outlet (Lower); W/Water Cooled			
Outlet (Lower); W/3-Speed Trans. ....	A61083			Trans. Cooler; W/4-Speed			
<b>V-6 3.0 L ENG.</b>				Trans.; W/A.C. ....	A61092		
Inlet (Upper) .....	A61084			Outlet (Lower); W/Water Cooled			
Outlet (Lower) .....	A61083			Trans. Cooler; W/4-Speed			
<b>V-6 3.3 L ENG.; V-6 3.8 L ENG.</b>				Trans.; W/O A.C. ....	A61085		
Rad. Oil Cooler Inlet (Upper);				Outlet Tube; W/Air Cooled Trans.			
W/Trlr. Tow. Pkg. ....	B61066			Cooler .....	B61064		
Rad. Oil Cooler Outlet (Lower);				<b>V-6 3.3 L ENG.; V-6 3.8 L ENG.</b>			
W/Trlr. Tow. Pkg. ....	B61065			"O" Ring; W/Water Cooled Trans.			ⓐA63093
<b>1995</b>				Cooler .....			
<b>V-6 3.0 L ENG.</b>				Inlet (Upper); W/Water Cooled			
"O" Ring; W/Water Cooled Trans.				Trans. Cooler; W/A.C. ....	A61094		
Cooler .....			A63093	Inlet (Upper); W/Water Cooled			
Inlet (Upper); W/Water Cooled				Trans. Cooler; W/O A.C. ....	A61091		
Trans. Cooler; W/A.C. ....	A61093			Inlet Hose; W/Air Cooled Trans.			
Inlet (Upper); W/Water Cooled				Cooler .....	A61063		
Trans. Cooler; W/O A.C. ....	A61087			Outlet (Lower); W/Water Cooled			
Inlet Hose; W/Air Cooled Trans.				Trans. Cooler; W/A.C. ....	A61092		
Cooler .....	A61063			Outlet (Lower); W/Water Cooled			
Outlet (Lower); W/Water Cooled				Trans. Cooler; W/O A.C. ....	A61090		
Trans. Cooler; W/A.C. ....	A61092			Outlet Tube; W/Air Cooled Trans.			
Outlet (Lower); W/Water Cooled				Cooler .....	B61064		
Trans. Cooler; W/O A.C. ....	A61085			<b>1993</b>			
Outlet Tube; W/Air Cooled Trans.				<b>V-6 3.0 L ENG.</b>			
Cooler .....	B61064			"O" Ring; W/Water Cooled Trans.			ⓐA63093
<b>V-6 3.3 L ENG.; V-6 3.8 L ENG.</b>				Cooler .....			
"O" Ring; W/Water Cooled Trans.			ⓐA63093	Inlet (Upper); W/Water Cooled			
Cooler .....				Trans. Cooler; W/O Rear A.C. ....	A61086		
Inlet (Upper); W/Water Cooled				Inlet (Upper); W/Water Cooled			
Trans. Cooler; W/A.C. ....	A61094			Trans. Cooler; W/Rear A.C. ....	A61087		
Inlet (Upper); W/Water Cooled				Inlet Hose; W/Air Cooled Trans.			
Trans. Cooler; W/O A.C. ....	A61091			Cooler .....	A61063		
Inlet Hose; W/Air Cooled Trans.				Outlet (Lower); W/Water Cooled			
Cooler .....	A61063			Trans. Cooler .....	A61085		
Outlet (Lower); W/Water Cooled				Outlet Tube; W/Air Cooled Trans.			
Trans. Cooler; W/A.C. ....	A61092			Cooler .....	B61064		
Outlet (Lower); W/Water Cooled				<b>V-6 3.3 L ENG.</b>			
Trans. Cooler; W/O A.C. ....	A61090			"O" Ring; W/Water Cooled Trans.			ⓐA63093
Outlet Tube; W/Air Cooled Trans.				Cooler .....			
Cooler .....	B61064			Inlet (Upper); W/Water Cooled			
<b>1994</b>				Trans. Cooler .....	A61091		
<b>V-6 3.0 L ENG.</b>				Inlet Hose; W/Air Cooled Trans.			
"O" Ring; W/Water Cooled Trans.			A63093	Cooler .....	A61063		
Cooler .....				Outlet (Lower); W/Water Cooled			
Inlet (Upper); W/Water Cooled				Trans. Cooler .....	A61090		
Trans. Cooler; W/3-Speed				Outlet Tube; W/Air Cooled Trans.			
Trans.; W/O Rear A.C. ....	A61062			Cooler .....	B61064		
Inlet (Upper); W/Water Cooled				<b>1992</b>			
Trans. Cooler; W/3-Speed				<b>V-6 3.0 L ENG.</b>			
Trans.; W/Rear A.C. ....	A61089			"O" Ring; W/Water Cooled Trans.			ⓐA63093
Inlet (Upper); W/Water Cooled				Cooler .....			
Trans. Cooler; W/4-Speed				<b>V-6 3.3 L ENG.</b>			
Trans.; W/A.C. ....	A61093			"O" Ring; W/Water Cooled Trans.			ⓐA63093
Inlet (Upper); W/Water Cooled				Cooler .....			
Trans. Cooler; W/4-Speed				Inlet Hose; W/Air Cooled Trans.			ⓐA63000
Trans.; W/O A.C. ....	A61087			Cooler; W/AWD .....			ⓐA63000
Inlet Hose; W/Air Cooled Trans.				Outlet Hose; W/Air Cooled Trans.			
Cooler .....	A61063			Cooler; W/AWD .....			
Outlet (Lower); W/Water Cooled				<b>1991</b>			
Trans. Cooler; W/3-Speed				<b>V-6 3.3 L ENG.</b>			
Trans.; W/O Rear A.C. ....	A61061			"O" Ring; W/Water Cooled Trans.			ⓐA63093
Outlet (Lower); W/Water Cooled				Cooler .....			
Trans. Cooler; W/3-Speed				Inlet Hose; W/Air Cooled Trans.			ⓐA63000
Trans.; W/Rear A.C. ....	A61088			Cooler; W/AWD .....			

ⓐ Two Required.  
 ⓑ Three Required.

Ⓒ Four Required.  
 Ⓓ Five Required.

Ⓔ Six Required.  
 Ⓕ Seven Required.

Ⓧ Cut To Fit.  
 ● As Required.

See Pages 1 - 10 for Engine Oil Cooler Applications.

# Transmission Oil Cooler Assemblies for Passenger Cars & Light Trucks

Application	Assembly Number	Hoses & Tubes	Connectors & Fittings	Application	Assembly Number	Hoses & Tubes	Connectors & Fittings
<b>DODGE - Continued</b>				<b>DODGE - Continued</b>			
<b>GRAND CARAVAN - Continued</b>				<b>MINI RAM VAN</b>			
<b>1991 - Continued</b>				<b>1988</b>			
<b>V-6 3.3 L ENG. - Continued</b>				<b>4-CYL. 2.5 L ENG.</b>			
Outlet Hose; W/Air Cooled Trans.				"O" Ring; W/Water Cooled Trans.			
Cooler; W/AWD.....		④A63000		Cooler.....			②A63093
<b>1990</b>				<b>MONACO</b>			
<b>V-6 3.3 L ENG.</b>				<b>1992-1990</b>			
"O" Ring; W/Water Cooled Trans.				<b>V-6 3.0 L ENG.</b>			
Cooler.....			②A63093	Inlet Fitting To Trans.....			A63035
<b>1989</b>				<b>4-CYL. 2.5 L ENG.; V-6 3.0 L ENG.</b>			
"O" Ring; W/Water Cooled Trans.				Inlet Hose From Rad. (Upper).....		④A63001	
Cooler.....			②A63093	Inlet Tube From Rad. (Upper).....		④A63005	
<b>1988</b>				<b>NEON</b>			
<b>4-CYL. 2.5 L ENG.</b>				<b>1999-1995</b>			
"O" Ring; W/Water Cooled Trans.				<b>4-CYL. 2.0 L ENG.</b>			
Cooler.....			②A63093	Inlet Hose (Pass. Side); W/A.C.....	A61077		
<b>INTREPID</b>				<b>2004-2002</b>			
<b>V-6 2.7 L ENG.</b>				<b>V-6 2.7 L ENG.</b>			
Inlet Fitting To Trans. (Lower).....			A63035	Inlet Fitting To Trans. (Lower).....			A63035
Inlet From Rad. (Upper).....	B61068			Inlet From Rad. (Upper).....	B61068		
Outlet Fitting To Trans. (Upper).....			A63035	Outlet Fitting To Trans. (Upper).....			A63035
Outlet From Rad. (Lower).....	B61067			Outlet From Rad. (Lower).....	B61067		
<b>V-6 3.5 L ENG.</b>				<b>V-6 3.5 L ENG.</b>			
Inlet Fitting To Trans. (Upper).....			A63035	Inlet Fitting To Trans. (Upper).....			A63035
Outlet Fitting To Trans. (Lower).....			A63035	Outlet Fitting To Trans. (Lower).....			A63035
<b>2001-2000</b>				<b>2001-2000</b>			
<b>V-6 2.7 L ENG.</b>				<b>V-6 2.7 L ENG.</b>			
Inlet Fitting To Trans. (Lower).....			A63035	Inlet Fitting To Trans. (Lower).....			A63035
Inlet From Rad. (Upper).....	B61068			Inlet From Rad. (Upper).....	B61068		
Outlet Fitting To Trans. (Upper).....			A63035	Outlet Fitting To Trans. (Upper).....			A63035
Outlet From Rad. (Lower).....	B61067			Outlet From Rad. (Lower).....	B61067		
<b>V-6 3.2 L ENG.; V-6 3.5 L ENG.</b>				<b>V-6 3.2 L ENG.; V-6 3.5 L ENG.</b>			
Inlet Fitting To Trans. (Upper).....			A63035	Inlet Fitting To Trans. (Upper).....			A63035
Outlet Fitting To Trans. (Lower).....			A63035	Outlet Fitting To Trans. (Lower).....			A63035
<b>1999-1998</b>				<b>1999-1998</b>			
<b>V-6 2.7 L ENG.</b>				<b>V-6 2.7 L ENG.</b>			
Inlet Fitting To Trans. (Lower).....			A63035	Inlet Fitting To Trans. (Lower).....			A63035
Inlet From Rad. (Upper).....	B61068			Inlet From Rad. (Upper).....	B61068		
Outlet Fitting To Trans. (Upper).....			A63035	Outlet Fitting To Trans. (Upper).....			A63035
Outlet From Rad. (Lower).....	B61067			Outlet From Rad. (Lower).....	B61067		
<b>V-6 3.2 L ENG.</b>				<b>V-6 3.2 L ENG.</b>			
Inlet Fitting To Trans. (Upper).....			A63035	Inlet Fitting To Trans. (Upper).....			A63035
Outlet Fitting To Trans. (Lower).....			A63035	Outlet Fitting To Trans. (Lower).....			A63035
<b>1997-1993</b>				<b>1997-1993</b>			
<b>V-6 3.3 L ENG.; V-6 3.5 L ENG.</b>				<b>V-6 3.3 L ENG.; V-6 3.5 L ENG.</b>			
Aux. Cooler Inlet (Pass. Side).....	A61072			Aux. Cooler Inlet (Pass. Side).....	A61072		
Aux. Cooler Outlet (Driver Side).....	B61073			Aux. Cooler Outlet (Driver Side).....	B61073		
Inlet (Upper).....	B61010			Inlet (Upper).....	B61010		
Inlet Fitting To Trans. (Upper).....			A63035	Inlet Fitting To Trans. (Upper).....			A63035
Outlet (Lower).....	B61011			Outlet (Lower).....	B61011		
Outlet Fitting To Trans. (Lower).....			A63035	Outlet Fitting To Trans. (Lower).....			A63035
<b>LANCER</b>				<b>LANCER</b>			
<b>1989-1986</b>				<b>1989-1986</b>			
<b>4-CYL. 2.2 L ENG.; 4-CYL. 2.5 L ENG.</b>				<b>4-CYL. 2.2 L ENG.; 4-CYL. 2.5 L ENG.</b>			
"O" Ring From Aux. Cooler.....			②A63093	"O" Ring From Aux. Cooler.....			②A63093

② Two Required.  
③ Three Required.

④ Four Required.  
⑤ Five Required.

⑥ Six Required.  
⑦ Seven Required.

✂ Cut To Fit.  
● As Required.

See Pages 1 - 10 for Engine Oil Cooler Applications.

## Transmission Oil Cooler Assemblies for Passenger Cars &amp; Light Trucks

Application	Assembly Number	Hoses & Tubes	Connectors & Fittings	Application	Assembly Number	Hoses & Tubes	Connectors & Fittings
<b>DODGE - Continued</b>				<b>DODGE - Continued</b>			
<b>RAM SERIES PICKUP - Continued</b>				<b>RAM SERIES PICKUP - Continued</b>			
<b>2002 - Continued</b>				<b>2000 - Continued</b>			
<b>V-10 8.0 L ENG.</b>				<b>V-8 5.2 L ENG.; V-8 5.9 L ENG.</b>			
Inlet Fitting To Trans.....			A63035	Aux. Cooler Supply From Rad. (Upper) .....	A61130		
Inlet Hose From Rad. (Upper).....	A61158			Inlet Fitting To Trans.....			A63035
Inlet Tube To Trans. (Upper).....	B61157			Inlet Hose From Rad. (Upper); W/Ext. Cab.....	A61156		
Outlet (Lower).....	B61020			Inlet Hose From Rad. (Upper); W/Std. Cab; Jan. 16 & Older.....	A61049		
Outlet Fitting To Trans.....			A63035	Inlet Hose From Rad. (Upper); W/Std. Cab; Jan. 17 & Newer.....	A61156		
				Inlet Tube To Trans. (Upper).....	B61204		
				Outlet Fitting To Trans.....			A63035
<b>2001</b>				<b>V-10 8.0 L ENG.</b>			
<b>6-CYL. 5.9 L DIESEL ENG.</b>				Inlet Fitting To Trans.; W/4-Speed 46RE Trans.....			
Inlet Fitting To Trans.; W/4-Speed 46RE Trans.....			A63035	Inlet Fitting To Trans.; W/4-Speed 47RE Trans.....			A63035
Inlet Fitting To Trans.; W/4-Speed 47RE Trans.....			A63033	Oil Cooler Outlet Hose To Trans. (Rear) .....	B61050		
Oil Cooler Outlet Hose To Trans. (Rear) .....	B61050			Outlet Fitting To Trans.; W/4-Speed 46RE Trans.....			A63035
Outlet Fitting To Trans.; W/4-Speed 46RE Trans.....			A63035	Outlet Fitting To Trans.; W/4-Speed 47RE Trans.....			A63033
Outlet Fitting To Trans.; W/4-Speed 47RE Trans.....			A63033				
<b>V-6 3.9 L ENG.</b>				<b>V-8 5.2 L ENG.; V-8 5.9 L ENG.</b>			
Inlet Fitting To Trans.....			A63035	Aux. Cooler Supply From Rad. (Upper) .....	A61130		
Inlet Hose From Rad. (Upper).....	A61156			Inlet Fitting To Trans.....			A63035
Inlet Tube To Trans. (Upper).....	B61160			Inlet Hose From Rad. (Upper); W/Aux. Cooler.....	A61049		
Outlet (Lower).....	B61168			Inlet Hose From Rad. (Upper); W/O Aux. Cooler.....	A61156		
Outlet Fitting To Trans.....			A63035	Inlet Tube To Trans. (Upper).....	B61204		
				Outlet Fitting To Trans.....			A63035
<b>V-8 5.2 L ENG.; V-8 5.9 L ENG.</b>				<b>1999</b>			
Aux. Cooler Supply From Rad. (Upper) .....	A61130			<b>6-CYL. 5.9 L DIESEL ENG.</b>			
Inlet Fitting To Trans.....			A63035	Aux. Cooler Inlet (Pass. Side).....	A61098		
Inlet Hose From Rad. (Upper); W/Aux. Cooler.....	A61049			Aux. Cooler Outlet (Driver Side).....	A61097		
Inlet Hose From Rad. (Upper); W/O Aux. Cooler.....	A61156			Inlet Fitting To Trans.; W/4-Speed 46RE Trans.....			A63035
Inlet Tube To Trans. (Upper).....	B61204			Inlet Fitting To Trans.; W/4-Speed 47RE Trans.....			A63033
Outlet Fitting To Trans.....			A63035	Oil Cooler Outlet Hose To Trans. (Rear) .....	B61050		
				Outlet Fitting To Trans.; W/4-Speed 46RE Trans.....			A63035
<b>V-10 8.0 L ENG.</b>				Outlet Fitting To Trans.; W/4-Speed 47RE Trans.....			
Inlet Fitting To Trans.; W/4-Speed 46RE Trans.....			A63035				A63033
Inlet Fitting To Trans.; W/4-Speed 47RE Trans.....			A63033	<b>V-6 3.9 L ENG.</b>			
Inlet Hose From Rad. (Upper).....	A61158			Inlet Fitting To Trans.....			A63035
Inlet Tube To Trans. (Upper).....	B61157			Inlet Hose From Rad. (Upper).....	A61156		
Outlet (Lower).....	B61020			Inlet Tube To Trans. (Upper).....	B61160		
Outlet Fitting To Trans.; W/4-Speed 46RE Trans.....			A63035	Outlet (Lower).....	B61168		
Outlet Fitting To Trans.; W/4-Speed 47RE Trans.....			A63033	Outlet Fitting To Trans.....			A63035
				<b>V-8 5.2 L ENG.; V-8 5.9 L ENG.</b>			
<b>2000</b>				Aux. Cooler Supply From Rad. (Upper) .....			
<b>6-CYL. 5.9 L DIESEL ENG.</b>				Inlet Fitting To Trans.....			
Aux. Cooler Inlet (Pass. Side).....	A61098			Inlet Hose From Rad. (Upper).....	A61156		
Aux. Cooler Outlet (Driver Side).....	A61097			Inlet Tube To Trans. (Upper).....	B61160		
Inlet Fitting To Trans.; W/4-Speed 46RE Trans.....			A63035	Outlet (Lower).....	B61168		
Inlet Fitting To Trans.; W/4-Speed 47RE Trans.....			A63033	Outlet Fitting To Trans.....			A63035
Oil Cooler Outlet Hose To Trans. (Rear) .....	B61050			<b>V-10 8.0 L ENG.</b>			
Outlet Fitting To Trans.; W/4-Speed 46RE Trans.....			A63035	Inlet Fitting To Trans.; W/4-Speed 46RE Trans.....			A63035
Outlet Fitting To Trans.; W/4-Speed 47RE Trans.....			A63033	Inlet Fitting To Trans.; W/4-Speed 47RE Trans.....			A63033
				Inlet Hose From Rad. (Upper).....	A61158		
<b>V-6 3.9 L ENG.</b>				Inlet Tube To Trans. (Upper).....			
Inlet Fitting To Trans.....			A63035	Outlet (Lower).....	B61020		
Inlet Hose From Rad. (Upper).....	A61156			Outlet Fitting To Trans.; W/4-Speed 46RE Trans.....			A63035
Inlet Tube To Trans. (Upper).....	B61160			Outlet Fitting To Trans.; W/4-Speed 47RE Trans.....			A63033
Outlet (Lower).....	B61168						
Outlet Fitting To Trans.....			A63035	<b>1998-1997</b>			
				<b>6-CYL. 5.9 L DIESEL ENG.</b>			
				Aux. Cooler Inlet (Pass. Side).....	A61098		

② Two Required.  
③ Three Required.

④ Four Required.  
⑤ Five Required.

⑥ Six Required.  
⑦ Seven Required.

≠ Cut To Fit.  
● As Required.

See Pages 1 - 10 for Engine Oil Cooler Applications.

# Transmission Oil Cooler Assemblies for Passenger Cars & Light Trucks

Application	Assembly Number	Hoses & Tubes	Connectors & Fittings	Application	Assembly Number	Hoses & Tubes	Connectors & Fittings
<b>DODGE - Continued</b>				<b>DODGE - Continued</b>			
<b>RAM SERIES PICKUP - Continued</b>				<b>RAM SERIES PICKUP - Continued</b>			
<b>1998-1997 - Continued</b>				<b>1996 - Continued</b>			
<b>6-CYL. 5.9 L DIESEL ENG. - Continued</b>				<b>V-6 3.9 L ENG. - Continued</b>			
Aux. Cooler Outlet (Driver Side).....	A61097			Inlet Hose From Rad. (Upper);			
Inlet Fitting To Trans.; W/4-Speed				W/46RH Trans. ....	A61049		
46RE Trans. ....			A63035	Inlet Tube To Trans. (Upper);			
Inlet Fitting To Trans.; W/4-Speed				W/42RH Trans. ....	B61160		
47RE Trans. ....			A63033	Inlet Tube To Trans. (Upper);			
Oil Cooler Hose Elbows.....	③A61081			W/46RH Trans. ....	B61101		
Oil Cooler Inlet Hose To Tube				Outlet (Lower).....	B61168		
(Front); W/O Sensor Port.....	A61142			Outlet Fitting To Trans.....			A63032
Oil Cooler Outlet Hose To Trans.				<b>V-8 5.2 L ENG.; V-8 5.9 L ENG.</b>			
(Rear).....	B61050			Aux. Cooler Supply From Rad.			
Oil Cooler Tube Connector (Upper				(Upper) .....	A61130		
Front).....		≧A63003		Inlet Fitting To Trans.....			A63035
Outlet Fitting To Trans.;				Inlet Hose From Rad. (Upper).....	A61156		
W/4-Speed 46RE Trans.....			A63035	Inlet Tube To Trans. (Upper).....	B61155		
Outlet Fitting To Trans.;				Outlet (Lower).....	B61018		
W/4-Speed 47RE Trans.....			A63033	Outlet Fitting To Trans.....			A63035
<b>V-6 3.9 L ENG.</b>				<b>V-10 8.0 L ENG.</b>			
Inlet Fitting To Trans.....			A63035	Inlet Hose From Rad. (Upper).....	A61158		
Inlet Hose From Rad. (Upper).....	A61156			Inlet Tube To Trans. (Upper).....	B61157		
Inlet Tube To Trans. (Upper).....	B61160			Outlet (Lower).....	B61020		
Outlet (Lower).....	B61168			Outlet Fitting To Trans.....			A63035
Outlet Fitting To Trans.....			A63035	<b>1995</b>			
<b>V-8 5.2 L ENG.; V-8 5.9 L ENG.</b>				<b>6-CYL. 5.9 L DIESEL ENG.</b>			
Aux. Cooler Supply From Rad.				Aux. Cooler Inlet (Pass. Side).....	A61098		
(Upper) .....	A61130			Aux. Cooler Outlet (Driver Side).....	A61097		
Inlet Fitting To Trans.....			A63035	Inlet Fitting To Trans.; W/4-Speed			
Inlet Hose From Rad. (Upper).....	A61156			46RE Trans. ....			A63035
Inlet Tube To Trans. (Upper).....	B61155			Inlet Fitting To Trans.; W/4-Speed			
Outlet (Lower).....	B61018			47RE Trans. ....			A63033
Outlet Fitting To Trans.....			A63035	Oil Cooler Hose Elbows.....	③A61081		
<b>V-10 8.0 L ENG.</b>				<b>V-6 3.9 L ENG.</b>			
Inlet Fitting To Trans.; W/4-Speed				Inlet Fitting To Trans.....			A63032
46RE Trans. ....			A63035	Inlet Hose From Rad. (Upper);			
Inlet Fitting To Trans.; W/4-Speed				W/42RH Trans. ....	A61156		
47RE Trans. ....			A63033	Inlet Hose From Rad. (Upper);			
Inlet Hose From Rad. (Upper).....	A61158			W/46RH Trans. ....	A61049		
Inlet Tube To Trans. (Upper).....	B61157			Inlet Tube To Trans. (Upper);			
Outlet (Lower).....	B61020			W/42RH Trans. ....	B61160		
Outlet Fitting To Trans.;				Inlet Tube To Trans. (Upper);			
W/4-Speed 46RE Trans.....			A63035	W/46RH Trans. ....	B61101		
Outlet Fitting To Trans.;				Outlet (Lower).....	B61168		
W/4-Speed 47RE Trans.....			A63033	Outlet Fitting To Trans.....			A63032
<b>1996</b>				<b>V-8 5.2 L ENG.; V-8 5.9 L ENG.</b>			
<b>6-CYL. 5.9 L DIESEL ENG.</b>				<b>Aux. Cooler Supply From Rad.</b>			
Aux. Cooler Inlet (Pass. Side).....	A61098			(Upper) .....	A61130		
Aux. Cooler Outlet (Driver Side).....	A61097			Inlet Fitting To Trans.....			A63032
Inlet Fitting To Trans.; W/4-Speed				Inlet Hose From Rad. (Upper);			
46RE Trans. ....			A63035	W/O Sensor Port On Tube.....	A61156		
Inlet Fitting To Trans.; W/4-Speed				Inlet Hose From Rad. (Upper);			
47RE Trans. ....			A63033	W/Sensor Port On Tube.....	A61049		
Oil Cooler Hose Elbows.....	③A61081			Inlet Tube To Trans. (Upper);			
Oil Cooler Inlet Hose To Tube				W/46RH Trans. ....	B61101		
(Front).....	A61142			Outlet (Lower).....	B61168		
Oil Cooler Inlet Tube To Trans.				Outlet Fitting To Trans.....			A63032
(Front).....	B61141			<b>V-8 5.2 L ENG.; V-8 5.9 L ENG.</b>			
Oil Cooler Outlet Hose To Trans.				Aux. Cooler Supply From Rad.			
(Rear) .....	B61050			(Upper) .....	A61130		
Oil Cooler Tube Connector (Upper				Inlet Fitting To Trans.....			A63032
Front).....		≧A63003		Inlet Hose From Rad. (Upper);			
Outlet Fitting To Trans.;				W/4-Speed 46RE Trans.....	A61156		
W/4-Speed 46RE Trans.....			A63035	Inlet Hose From Rad. (Upper);			
Outlet Fitting To Trans.;				W/Sensor Port On Tube.....	A61049		
W/4-Speed 47RE Trans.....			A63033	Inlet Tube To Trans. (Upper);			
<b>V-6 3.9 L ENG.</b>				<b>W/Sensor Port On Tube.....</b>			
Inlet Fitting To Trans.....			A63032	Sensor Port .....	B61155		
Inlet Hose From Rad. (Upper);				Inlet Tube To Trans. (Upper);			
W/42RH Trans. ....				W/Sensor.....	B61048		
Inlet Tube To Trans. (Upper);				Outlet (Lower).....	B61018		
W/42RH Trans. ....				Outlet Fitting To Trans.....			A63032
Inlet Tube To Trans. (Upper);							
W/46RH Trans. ....							
Outlet (Lower).....							
Outlet Fitting To Trans.....							

② Two Required.  
③ Three Required.

④ Four Required.  
⑤ Five Required.

⑥ Six Required.  
⑦ Seven Required.

≧ Cut To Fit.  
● As Required.

See Pages 1 - 10 for Engine Oil Cooler Applications.

## Transmission Oil Cooler Assemblies for Passenger Cars &amp; Light Trucks

Application	Assembly Number	Hoses & Tubes	Connectors & Fittings	Application	Assembly Number	Hoses & Tubes	Connectors & Fittings
<b>DODGE - Continued</b>				<b>DODGE - Continued</b>			
<b>RAM SERIES PICKUP - Continued</b>				<b>RAMCHARGER</b>			
<b>1995 - Continued</b>				<b>1993-1990</b>			
<b>V-10 8.0 L ENG.</b>				<b>V-8 5.2 L ENG.; V-8 5.9 L ENG.</b>			
Inlet Hose From Rad. (Upper).....	A61158			Inlet Fitting To Trans.....			A63035
Outlet (Lower).....	B61020			Inlet Hose (Pass. Side).....	✂ A63001		
<b>1994</b>				Inlet Tube (Pass. Side).....	✂ A63005		A63035
<b>6-CYL. 5.9 L DIESEL ENG.</b>				Outlet Fitting To Trans.....			A63035
Aux. Cooler Inlet (Pass. Side).....	A61098			Outlet Hose (Driver Side).....	✂ A63001		
Aux. Cooler Outlet (Driver Side).....	A61097			Outlet Tube (Driver Side).....	✂ A63005		
Inlet Fitting To Trans.; W/4-Speed 46RE Trans. ....			A63035	<b>1989-1984</b>			
Inlet Fitting To Trans.; W/4-Speed 47RE Trans. ....			A63033	<b>V-8 5.2 L ENG.; V-8 5.9 L ENG.</b>			
Oil Cooler Hose Elbows.....	③ A61081			Inlet Fitting To Trans.....			A63042
Oil Cooler Inlet Hose To Tube (Front).....	A61142			Inlet Hose (Pass. Side).....	✂ A63000		
Oil Cooler Inlet Tube To Trans. (Front).....	B61141			Inlet Tube (Pass. Side).....	✂ A63004		A63042
Oil Cooler Outlet Hose To Trans. (Rear).....	B61050			Outlet Fitting To Trans.....			A63042
Oil Cooler Tube Connector (Upper Front).....		✂ A63003		Outlet Hose (Driver Side).....	✂ A63000		
Outlet Fitting To Trans.; W/4-Speed 46RE Trans.....			A63035	Outlet Tube (Driver Side).....	✂ A63004		
Outlet Fitting To Trans.; W/4-Speed 47RE Trans.....			A63033	<b>SHADOW</b>			
<b>V-6 3.9 L ENG.</b>				<b>1991-1988</b>			
Inlet Fitting To Trans.....			A63032	<b>4-CYL. 2.2 L ENG.; 4-CYL. 2.5 L ENG.</b>			
Inlet Hose From Rad. (Upper); W/42RH Trans. ....	A61156			"O" Ring; W/O Water Cooled Trans. Cooler .....			② A63093
Inlet Hose From Rad. (Upper); W/46RH Trans. ....	A61049			<b>1987</b>			
Inlet Tube To Trans. (Upper); W/42RH Trans. ....	B61160			<b>4-CYL. 2.2 L ENG.</b>			
Inlet Tube To Trans. (Upper); W/46RH Trans. ....	B61101			"O" Ring; W/Water Cooled Trans. Cooler.....			② A63093
Outlet (Lower).....	B61168			<b>SPIRIT</b>			
Outlet Fitting To Trans.....			A63032	<b>1995-1991</b>			
<b>V-8 5.2 L ENG.</b>				<b>V-6 3.0 L ENG.</b>			
Aux. Cooler Supply From Rad. (Upper).....	A61130			"O" Ring; W/Water Cooled Trans. Cooler.....			② A63093
Inlet Fitting To Trans.....			A63032	<b>1990-1989</b>			
Inlet Hose From Rad. (Upper); W/O Sensor Port On Tube.....	A61156			<b>4-CYL. 2.5 L ENG.; V-6 3.0 L ENG.</b>			
Inlet Hose From Rad. (Upper); W/Sensor Port On Tube.....	A61049			"O" Ring; W/Water Cooled Trans. Cooler.....			② A63093
Inlet Tube To Trans. (Upper); W/O Sensor Port.....	B61155			<b>STEALTH</b>			
Inlet Tube To Trans. (Upper); W/Sensor.....	B61048			<b>1996-1995</b>			
Outlet (Lower).....	B61018			<b>V-6 3.0 L ENG.</b>			
Outlet Fitting To Trans.....			A63032	Banjo Washers.....			
<b>V-8 5.9 L ENG.</b>				⑧ A63109			
Inlet Fitting To Trans.....			A63032	<b>1994-1992</b>			
Inlet Hose From Rad. (Upper); W/O Sensor Port On Tube.....	A61156			<b>V-6 3.0 L ENG.</b>			
Inlet Hose From Rad. (Upper); W/Sensor Port On Tube.....	A61049			"O" Ring To Trans. ....			
Inlet Tube To Trans. (Upper); W/O Sensor Port.....	B61155			Banjo Washers (Aux. Cooler).....			
Inlet Tube To Trans. (Upper); W/Sensor.....	B61048			② A63097			
Oil Cooler Inlet Tube To Trans. (Front).....	B61141			④ A63109			
Outlet (Lower).....	B61018			<b>1991</b>			
Outlet Fitting To Trans.....			A63032	<b>V-6 3.0 L ENG.</b>			
<b>V-10 8.0 L ENG.</b>				"O" Ring To Trans. ....			
Inlet Hose From Rad. (Upper).....	A61158			② A63097			
Outlet (Lower).....	B61020			<b>STRATUS</b>			
<b>1993-2001</b>				<b>2003-2001</b>			
<b>4-CYL. 2.4 L ENG.</b>				<b>4-CYL. 2.4 L ENG.</b>			
Banjo Washers; W/SOHC Eng. ....				Banjo Washers; W/SOHC Eng. ....			
④ A63100				④ A63100			
<b>V-6 3.0 L ENG.</b>				<b>V-6 3.0 L ENG.</b>			
Banjo Washers.....				Banjo Washers.....			
④ A63100				④ A63100			

② Two Required.  
③ Three Required.

④ Four Required.  
⑤ Five Required.

⑥ Six Required.  
⑦ Seven Required.

✂ Cut To Fit.  
● As Required.

See Pages 1 - 10 for Engine Oil Cooler Applications.



# Transmission Oil Cooler Assemblies for Passenger Cars & Light Trucks

Application	Assembly Number	Hoses & Tubes	Connectors & Fittings	Application	Assembly Number	Hoses & Tubes	Connectors & Fittings
<b>DODGE - Continued</b>				<b>EAGLE - Continued</b>			
<b>STRATUS - Continued</b>				<b>TALON - Continued</b>			
<b>2000</b>				<b>1994-1993 - Continued</b>			
<b>V-6 2.5 L ENG.</b>				<b>4-CYL. 2.0 L ENG. - Continued</b>			
Inlet Hose (Pass. Side).....	B61038			Banjo Washers.....			④A63109
<b>1999-1998</b>				Inlet Hose; W/O Turbo.....		✂A63000	
<b>V-6 2.5 L ENG.</b>				Outlet Hose; W/O Turbo.....		✂A63000	
Inlet (Upper).....	B61038			<b>1992-1990</b>			
Outlet (Lower).....	A61039			<b>4-CYL. 2.0 L ENG.</b>			
<b>1997-1996</b>				"O" Ring To Trans. ....			②A63097
<b>4-CYL. 2.0 L ENG.; 4-CYL. 2.4 L ENG.</b>				Banjo Washers.....			④A63109
Inlet (Pass. Side).....	A61079			Inlet Hose; W/O Turbo.....		✂A63000	
Outlet (Driver Side).....	A61080			Outlet Hose; W/O Turbo.....		✂A63000	
<b>V-6 2.5 L ENG.</b>				<b>VISION</b>			
Inlet (Upper).....	B61038			<b>1997</b>			
Outlet (Lower).....	A61039			<b>V-6 3.3 L ENG. (CANADA); V-6 3.5 L ENG.</b>			
<b>1995</b>				Aux. Cooler Inlet (Pass. Side).....	A61072		
<b>4-CYL. 2.0 L ENG.; 4-CYL. 2.4 L ENG.</b>				Aux. Cooler Outlet (Driver Side).....	B61073		
Aux. Cooler Inlet Tube (Pass. Side).....	A61040			Inlet (Upper).....	B61010		
Aux. Cooler Outlet Tube (Driver Side).....	A61041			Inlet Fitting To Trans. (Upper).....			A63035
Inlet (Pass. Side).....	A61079			Outlet (Lower).....	B61011		A63035
Outlet (Driver Side).....	A61080			Outlet Fitting To Trans. (Lower).....			A63035
<b>V-6 2.5 L ENG.</b>				<b>1996-1993</b>			
Aux. Cooler Inlet Tube (Pass. Side).....	A61040			<b>V-6 3.3 L ENG.; V-6 3.5 L ENG.</b>			
Aux. Cooler Outlet Tube (Driver Side).....	A61041			Aux. Cooler Inlet (Pass. Side).....	A61072		
Inlet (Upper).....	B61038			Aux. Cooler Outlet (Driver Side).....	B61073		
Outlet (Lower).....	A61039			Inlet (Upper).....	B61010		
<b>600</b>				Inlet Fitting To Trans. (Upper).....			A63035
<b>1988-1986</b>				Outlet (Lower).....	B61011		A63035
<b>4-CYL. 2.2 L ENG.; 4-CYL. 2.5 L ENG.</b>				Outlet Fitting To Trans. (Lower).....			A63035
"O" Ring From Aux. Cooler.....				<b>1996-1993</b>			
			②A63093	<b>V-6 3.0 L ENG.; V-6 4.0 L ENG.</b>			
<b>EAGLE</b>				"O" Ring (Connector & Fitting).....			●A63090
<b>PREMIER</b>				Inlet Hose.....		✂A63001	
<b>1992-1988</b>				Inlet Tube.....		✂A63005	
<b>V-6 3.0 L ENG.</b>				Outlet Hose.....		✂A63001	
Inlet Fitting To Trans.....			A63035	Outlet Tube.....		✂A63005	
Inlet Hose From Rad. (Upper).....	✂A63001			Tube Nut To Trans. ....			②A63013
Inlet Tube From Rad. (Upper).....	✂A63005			<b>1989-1987</b>			
Inlet Tube To Trans. (Upper).....	✂A63005			<b>V-6 3.0 L ENG.</b>			
Outlet Fitting To Trans. ....			A63035	"O" Ring (Connector & Fitting).....			●A63090
Outlet Tube To Trans. (Lower).....	✂A63005			Inlet Hose.....		✂A63001	
<b>TALON</b>				Inlet Tube.....		✂A63005	
<b>1998-1995</b>				Outlet Hose.....		✂A63001	
<b>4-CYL. 2.0 L ENG.</b>				Outlet Tube.....		✂A63005	
Banjo Washers; W/Turbo.....			④A63109	Tube Nut To Trans. ....			②A63013
Tube To Tube; W/O Turbo.....		✂A63000		<b>ASPIRE</b>			
<b>1994-1993</b>				<b>1997-1994</b>			
<b>4-CYL. 1.8 L ENG.</b>				<b>4-CYL. 1.3 L ENG.</b>			
"O" Ring To Trans. ....			②A63097	Banjo Washers From Pump.....			②A63103
Banjo Washers.....			④A63109	Banjo Washers To Trans.....			②A63100
Inlet Hose.....		✂A63000		<b>BRONCO</b>			
Outlet Hose.....		✂A63000		<b>1996-1993</b>			
<b>4-CYL. 2.0 L ENG.</b>				<b>V-8 5.0 L ENG.; V-8 5.8 L ENG.</b>			
"O" Ring To Trans. ....			②A63097	"O" Ring (Connector & Fitting).....			●A63094
				Connector From Rad. ....			②A63050

② Two Required.  
③ Three Required.

④ Four Required.  
⑤ Five Required.

⑥ Six Required.  
⑦ Seven Required.

✂ Cut To Fit.  
● As Required.

See Pages 1 - 10 for Engine Oil Cooler Applications.

## Transmission Oil Cooler Assemblies for Passenger Cars &amp; Light Trucks

Application	Assembly Number	Hoses & Tubes	Connectors & Fittings	Application	Assembly Number	Hoses & Tubes	Connectors & Fittings
<b>FORD - Continued</b>				<b>FORD - Continued</b>			
<b>BRONCO - Continued</b>				<b>COUNTRY SQUIRE - Continued</b>			
<b>1996-1993 - Continued</b>				<b>1988 - Continued</b>			
<b>V-8 5.0 L ENG.; V-8 5.8 L ENG. - Continued</b>				<b>V-8 5.0 L ENG. - Continued</b>			
Inlet Hose .....		✕A63000		Inlet Tube .....		✕A63004	
Inlet Tube .....		✕A63004		Outlet Fitting To Trans.; Apr. 17 & Older .....			A63049
Outlet Hose .....		✕A63000		Outlet Hose .....		✕A63000	
Outlet Tube .....		✕A63004		Outlet Tube .....		✕A63004	
Tube Nut From Rad. ....			②A63047	Tube Nut From Rad. ....			②A63047
Tube Nut To Trans. ....			②A63011	Tube Nut To Trans. ....			②A63011
<b>1992-1991</b>				<b>CROWN VICTORIA</b>			
<b>6-CYL. 4.9 L ENG.; V-8 5.0 L ENG.; V-8 5.8 L ENG.</b>				<b>2003-2000</b>			
"O" Ring (Connector & Fitting) .....			●A63094	<b>V-8 4.6 L ENG.</b>			
Connector From Rad. ....			②A63050	"O" Ring (Fitting) .....			
Inlet Hose .....		✕A63000		Aux. Cooler Hose .....			
Inlet Tube .....		✕A63004		Inlet & Outlet Assy. ....			
Outlet Hose .....		✕A63000			B61016		●A63094
Outlet Tube .....		✕A63004		<b>1999-1998</b>			
Tube Nut From Rad. ....			②A63047	<b>V-8 4.6 L ENG.</b>			
Tube Nut To Trans. ....			②A63011	"O" Ring (Connector & Fitting) .....			
<b>1990-1988</b>				Connector From Rad. ....			
<b>6-CYL. 4.9 L ENG.; V-8 5.0 L ENG.; V-8 5.8 L ENG.</b>				Inlet Hose .....			
"O" Ring (Connector & Fitting) .....			●A63094	Inlet Tube .....			
Connector From Rad. ....			②A63050	Outlet Hose .....			
Inlet Hose .....		✕A63000		Outlet Tube .....			
Inlet Tube .....		✕A63004		Tube Nut From Rad. ....			
Outlet Hose .....		✕A63000		Tube Nut To Trans. ....			
Outlet Tube .....		✕A63004		<b>V-6 2.9 L ENG.</b>			
Tube Nut From Rad. ....			②A63047	"O" Ring (Connector & Fitting) .....			
Tube Nut To Trans. ....			②A63011	Inlet Hose .....			
<b>CONTOUR</b>				Inlet Tube .....			
<b>1997</b>				Outlet Hose .....			
<b>4-CYL. 2.0 L ENG.; V-6 2.5 L ENG.</b>				Outlet Tube .....			
"O" Ring (Fitting); Nov. 23 & Older. ....			②A63090	Tube Nut From Rad. ....			
<b>1996-1995</b>				Tube Nut To Trans. ....			
<b>4-CYL. 2.0 L ENG.; V-6 2.5 L ENG.</b>				<b>V-6 2.9 L ENG.</b>			
"O" Ring (Fitting) .....			②A63090	"O" Ring (Connector & Fitting) .....			
<b>COUNTRY SQUIRE</b>				Inlet Hose .....			
<b>1991-1989</b>				Inlet Tube .....			
<b>V-8 5.0 L ENG.</b>				Outlet Hose .....			
"O" Ring (Connector & Fitting) .....			●A63094	Outlet Tube .....			
Connector From Rad. ....			②A63050	Tube Nut From Rad. ....			
Inlet Hose .....		✕A63000		Tube Nut To Trans. ....			
Inlet Tube .....		✕A63004		<b>CONTOUR</b>			
Outlet Hose .....		✕A63000		<b>1997</b>			
Outlet Tube .....		✕A63004		<b>4-CYL. 2.0 L ENG.; V-6 2.5 L ENG.</b>			
Tube Nut From Rad. ....			②A63047	"O" Ring (Fitting); Nov. 23 & Older. ....			
Tube Nut To Trans. ....			②A63011	<b>1996-1995</b>			
<b>1988</b>				<b>4-CYL. 2.0 L ENG.; V-6 2.5 L ENG.</b>			
<b>V-8 5.0 L ENG.</b>				"O" Ring (Fitting) .....			
"O" Ring (Connector) .....			②A63094	"O" Ring (Fitting) .....			
"O" Ring (Fitting); Apr. 18 & Newer			②A63094	"O" Ring (Fitting) .....			
Connector From Rad. ....			②A63050	"O" Ring (Fitting) .....			
Inlet Fitting To Trans.; Apr. 17 & Older .....			A63049	"O" Ring (Fitting) .....			
Inlet Hose .....		✕A63000		"O" Ring (Fitting) .....			
<b>1988</b>				"O" Ring (Fitting) .....			
<b>V-8 5.0 L ENG.</b>				"O" Ring (Fitting) .....			
"O" Ring (Connector) .....			②A63094	"O" Ring (Fitting) .....			
"O" Ring (Fitting); Apr. 18 & Newer			②A63094	"O" Ring (Fitting) .....			
Connector From Rad. ....			②A63050	"O" Ring (Fitting) .....			
Inlet Fitting To Trans.; Apr. 17 & Older .....			A63049	"O" Ring (Fitting) .....			
Inlet Hose .....		✕A63000		"O" Ring (Fitting) .....			

② Two Required.  
③ Three Required.

④ Four Required.  
⑤ Five Required.

⑥ Six Required.  
⑦ Seven Required.

✕ Cut To Fit.  
● As Required.

See Pages 1 - 10 for Engine Oil Cooler Applications.

# Transmission Oil Cooler Assemblies for Passenger Cars & Light Trucks

Application	Assembly Number	Hoses & Tubes	Connectors & Fittings	Application	Assembly Number	Hoses & Tubes	Connectors & Fittings
<b>FORD - Continued</b>				<b>FORD - Continued</b>			
<b>E SERIES VAN - Continued</b>				<b>E SERIES VAN - Continued</b>			
<b>2003-1999 - Continued</b>				<b>1998-1997 - Continued</b>			
<b>V-6 4.2 L ENG. - Continued</b>				<b>V-8 5.4 L ENG. - Continued</b>			
Aux. Cooler Inlet Hose (Driver Side).....		≡A63000		Outlet To Trans. (Front); W/E4OD/4R100 Trans. ....	B61310		
Aux. Cooler Outlet Hose (Pass. Side).....		≡A63000		<b>V-8 7.3 L DIESEL ENG.; V-10 6.8 L ENG.</b>			
Connector From Rad.; W/1/4" Male Pipe Thread.....			●A63050	"O" Ring (Connector).....			●A63094
Inlet (Upper).....	B61308			Aux. Cooler Inlet Hose (Driver Side).....		≡A63001	
<b>V-8 4.6 L ENG.</b>				Aux. Cooler Outlet Hose (Pass. Side).....		≡A63001	
"O" Ring (Connector & Fitting).....			●A63094	By Pass Valve Washers (Front).....			●A63105
Aux. Cooler Inlet Hose (Driver Side).....		≡A63000		By Pass Valve Washers (Rear).....			●A63106
Aux. Cooler Outlet Hose (Pass. Side).....		≡A63000		Connector From Rad.; W/1/4" Male Pipe Thread.....			ⓐA63050
Connector From Rad.; W/1/4" Male Pipe Thread.....			●A63050	<b>1996-1988</b>			
Inlet (Upper).....	B61307			<b>6-CYL. 4.9 L ENG.; V-8 5.0 L ENG.; V-8 5.8 L ENG.; V-8 7.3 L DIESEL ENG.; V-8 7.5 L ENG.</b>			
Outlet (Lower).....	B61309			"O" Ring (Connector & Fitting).....			●A63094
<b>V-8 5.4 L ENG.</b>				By Pass Valve Washers (Front); W/535 I.D. Washer; W/4-Speed Auto. Trans.....			●A63105
"O" Ring (Connector).....			●A63094	By Pass Valve Washers (Rear); W/668 I.D. Washer; W/4-Speed Auto. Trans.....			●A63106
Aux. Cooler Inlet Hose (Driver Side).....		≡A63001		Connector From Rad.; W/1/4" Male Pipe Thread.....			ⓐA63050
Aux. Cooler Outlet Hose (Pass. Side).....		≡A63001		Inlet Hose.....		≡A63000	
By Pass Valve Washers (Front); W/4R100 Trans.....			●A63105	Inlet Tube.....		≡A63004	
By Pass Valve Washers (Rear); W/4R100 Trans.....			●A63106	Outlet Hose.....		≡A63000	
Connector From Rad.; W/1/4" Male Pipe Thread.....			ⓐA63050	Outlet Tube.....		≡A63004	
Inlet To Trans. (Rear); W/4R100 Trans. ....	B61306			Tube Nut From Rad.....			ⓐA63047
Outlet To Trans. (Front); W/4R100 Trans. ....	B61310			Tube Nut To Trans. ....			ⓐA63011
				Washer From Rad.....			A63107
<b>1998-1997</b>				<b>ESCORT</b>			
<b>V-6 4.2 L ENG.</b>				<b>2002-1997</b>			
"O" Ring (Connector & Fitting).....			●A63094	<b>4-CYL. 2.0 L ENG.</b>			
Aux. Cooler Inlet Hose (Driver Side).....		≡A63000		Banjo Washers; W/14mm I.D. Banjo.....			
Aux. Cooler Outlet Hose (Pass. Side).....		≡A63000					
Connector From Rad.; W/1/4" Male Pipe Thread.....			ⓐA63050	Banjo Washers; W/16mm I.D. Banjo.....			
Inlet (Upper).....	B61308			Outlet Hose.....			
<b>V-8 4.6 L ENG.</b>							
"O" Ring (Connector & Fitting).....			●A63094	<b>1995-1991</b>			
Aux. Cooler Inlet Hose (Driver Side).....		≡A63000		<b>4-CYL. 1.8 L ENG.; 4-CYL. 1.9 L ENG.</b>			
Aux. Cooler Outlet Hose (Pass. Side).....		≡A63000		Banjo Washers; W/14mm I.D. Banjo.....			
Connector From Rad.; W/1/4" Male Pipe Thread.....			ⓐA63050				
Inlet (Upper).....	B61307			Banjo Washers; W/16mm I.D. Banjo.....			
Outlet (Lower).....	B61309			Outlet Hose.....			
<b>V-8 5.4 L ENG.</b>							
"O" Ring (Connector).....			●A63094	<b>1990-1988</b>			
Aux. Cooler Inlet Hose (Driver Side).....		≡A63001		<b>4-CYL. 1.9 L ENG.</b>			
Aux. Cooler Outlet Hose (Pass. Side).....		≡A63001		"O" Ring (Connector & Fitting).....			
By Pass Valve Washers (Front); W/E4OD/4R100 Trans.....			●A63105	Connector From Rad.; W/Auto. Overdrive Trans. ....			
By Pass Valve Washers (Rear); W/E4OD/4R100 Trans.....			●A63106	Inlet Fitting To Trans.; W/Factory Inst. Fitting.....			
Connector From Rad.; W/1/4" Male Pipe Thread.....			ⓐA63050	Inlet Hose.....			
Inlet (Upper); W/4R70W Trans. ....	B61307			Inlet Tube.....			
Inlet To Trans. (Rear); W/E4OD/4R100 Trans. ....	B61306			Outlet Fitting To Trans.; W/Factory Inst. Fitting.....			
				Outlet Hose.....			
				Outlet Tube.....			
				Tube Nut From Rad.; W/Auto. Overdrive Trans. ....			
				Tube Nut To Trans.; Service Item...			

② Two Required.  
③ Three Required.

④ Four Required.  
⑤ Five Required.

⑥ Six Required.  
⑦ Seven Required.

≡ Cut To Fit.  
● As Required.

See Pages 1 - 10 for Engine Oil Cooler Applications.



# Transmission Oil Cooler Assemblies for Passenger Cars & Light Trucks

Application	Assembly Number	Hoses & Tubes	Connectors & Fittings	Application	Assembly Number	Hoses & Tubes	Connectors & Fittings
<b>FORD - Continued</b>				<b>FORD - Continued</b>			
<b>EXPEDITION - Continued</b>				<b>EXPEDITION - Continued</b>			
<b>2001 - Continued</b>				<b>1998 - Continued</b>			
<b>V-8 5.4 L ENG. - Continued</b>				<b>V-8 4.6 L ENG. - Continued</b>			
By Pass Valve Washers (Front).....			●A63105	Inlet From Rad. (Lower); W/O Aux. Cooler.....	B61188		
By Pass Valve Washers (Rear).....			●A63106	Inlet To Trans. (Upper); W/Aux. Cooler.....	B61189		
Outlet From Rad. (Upper).....	B61282			Outlet From Rad. (Upper).....	B61191		
<b>2000</b>				<b>V-8 5.4 L ENG.</b>			
<b>V-8 4.6 L ENG.</b>				"O" Ring (Connector).....			
"O" Ring (Connector & Fitting); W/3/8" Tubing.....			●A63090	Aux. Cooler Inlet Tube Fitting (Pass. Side).....	A61019		●A63090
"O" Ring (Connector & Fitting); W/5/16" Tubing.....			●A63094	Aux. Cooler Outlet (Driver Side).....	B61193		
Aux. Cooler Inlet Tube Fitting (Pass. Side); W/Super Cooling....	A61017			By Pass Valve Washers (Front).....			●A63105
Aux. Cooler Outlet (Driver Side); W/Super Cooling.....	B61192			By Pass Valve Washers (Rear).....			●A63106
Inlet From Rad. (Lower); W/O Aux. Cooler; Under 8500 G.V.W. ....	B61196			Inlet From Rad. (Lower); W/O Aux. Cooler.....	B61186		
Inlet To Trans. (Upper); W/Super Cooling; Under 8500 G.V.W. ....	B61189			Inlet To Trans. (Rear); W/Aux. Cooler.....	B61187		
Outlet From Rad. (Upper); W/Super Cooling.....	B61197			Outlet From Rad. (Upper); W/Aux. Cooler.....	B61198		
<b>V-8 5.4 L ENG.</b>				"O" Ring (Connector).....			
"O" Ring (Connector).....			●A63090	Aux. Cooler Inlet Tube Fitting (Pass. Side).....	A61019		
Aux. Cooler Inlet Tube Fitting (Pass. Side).....	B61193			Aux. Cooler Outlet (Driver Side).....	B61193		
Aux. Cooler Outlet (Driver Side).....			●A63105	By Pass Valve Washers (Front).....			●A63106
By Pass Valve Washers (Front).....			●A63106	By Pass Valve Washers (Rear).....			
By Pass Valve Washers (Rear).....				Inlet From Rad. (Lower); W/O Aux. Cooler.....	B61186		
Inlet From Rad. (Lower); W/O Aux. Cooler.....	B61186			Inlet To Trans. (Rear); W/Aux. Cooler.....	B61187		
Inlet To Trans. (Rear); W/Aux. Cooler.....	B61187			Outlet From Rad. (Upper); W/Aux. Cooler.....	B61198		
Outlet From Rad. (Upper); W/Aux. Cooler.....	B61198						
<b>1999</b>				<b>1997</b>			
<b>V-8 4.6 L ENG.</b>				<b>V-8 4.6 L ENG.</b>			
"O" Ring (Connector & Fitting); W/3/8" Tubing.....			●A63090	"O" Ring (Connector & Fitting).....			●A63094
"O" Ring (Connector & Fitting); W/5/16" Tubing.....			●A63094	Aux. Cooler Inlet Hose (Pass. Side).....		⊗A63000	
Aux. Cooler Outlet (Driver Side).....	B61192			Aux. Cooler Inlet Tube Fitting (Pass. Side).....	A61017		
Inlet From Rad. (Lower); W/O Aux. Cooler.....	B61196			Aux. Cooler Outlet (Driver Side).....	B61192		
Inlet To Trans. (Upper); W/Aux. Cooler.....	B61189			Inlet From Rad. (Lower); W/O Aux. Cooler.....	B61188		
Outlet From Rad. (Upper).....	B61197			Inlet To Trans. (Upper); W/Aux. Cooler.....	B61189		
				Outlet From Rad. (Upper).....			
				B61191			
<b>V-8 5.4 L ENG.</b>				<b>V-8 5.4 L ENG.</b>			
"O" Ring (Connector).....			●A63090	"O" Ring (Connector).....			●A63090
Aux. Cooler Inlet Tube Fitting (Pass. Side).....	A61019			Aux. Cooler Inlet Tube Fitting (Pass. Side).....	A61019		
Aux. Cooler Outlet (Driver Side).....	B61193			Aux. Cooler Outlet (Driver Side).....	B61193		
By Pass Valve Washers (Front).....			●A63105	By Pass Valve Washers (Front).....			●A63105
By Pass Valve Washers (Rear).....			●A63106	By Pass Valve Washers (Rear).....			●A63106
Inlet From Rad. (Lower); W/O Aux. Cooler.....	B61186			Inlet From Rad. (Lower); W/O Aux. Cooler.....	B61186		
Inlet To Trans. (Rear); W/Aux. Cooler.....	B61187			Inlet To Trans. (Rear); W/Aux. Cooler.....	B61187		
Outlet From Rad. (Upper).....	B61197			Outlet From Rad. (Upper); W/Aux. Cooler.....	B61190		
				Outlet From Rad. (Upper); W/O Aux. Cooler.....			
				B61194			
<b>1998</b>				<b>EXPLORER</b>			
<b>V-8 4.6 L ENG.</b>				<b>2002</b>			
"O" Ring (Connector & Fitting).....			●A63094	<b>V-6 4.0 L ENG.</b>			
Aux. Cooler Inlet Hose (Pass. Side).....		⊗A63000		"O" Ring (Connector & Fitting).....			②A63090
Aux. Cooler Inlet Tube Fitting (Pass. Side).....	A61017			Aux. Cooler Hose.....		⊗A63001	
Aux. Cooler Outlet (Driver Side).....	B61192			<b>2001-1998</b>			
By Pass Valve Washers (Front).....			●A63105	<b>V-6 4.0 L ENG.</b>			
By Pass Valve Washers (Rear).....			●A63106	"O" Ring (Connector & Fitting).....			②A63090
Inlet From Rad. (Lower); W/O Aux. Cooler.....	B61186			Aux. Cooler Hose.....		⊗A63001	
Inlet To Trans. (Upper); W/Aux. Cooler.....	B61187			Aux. Cooler Outlet (Lower).....	B61279		
Outlet From Rad. (Upper).....	B61197			Inlet From Rad. (Lower); W/O Aux. Cooler.....	B61277		
				Inlet To Trans. (Upper); W/Aux. Cooler.....			
				B61278			
				Outlet To Trans. (Lower).....			
				B61280			

② Two Required.  
③ Three Required.

④ Four Required.  
⑤ Five Required.

⑥ Six Required.  
⑦ Seven Required.

⊗ Cut To Fit.  
● As Required.

See Pages 1 - 10 for Engine Oil Cooler Applications.

Product Section

Troubleshooting

EOC Applications

TOC Applications

Numerical Listing

Manufacturers' Part Numbers

End Fittings

Illustrations

## Transmission Oil Cooler Assemblies for Passenger Cars &amp; Light Trucks

Application	Assembly Number	Hoses & Tubes	Connectors & Fittings	Application	Assembly Number	Hoses & Tubes	Connectors & Fittings
<b>FORD - Continued</b>				<b>FORD - Continued</b>			
<b>EXPLORER - Continued</b>				<b>F SERIES PICKUP - Continued</b>			
<b>2001-1998 - Continued</b>				<b>2002 - Continued</b>			
<b>V-8 5.0 L ENG.</b>				<b>V-8 5.4 L ENG. - Continued</b>			
"O" Ring (Connector & Fitting) .....			②A63090	"O" Ring (Connector & Fitting); W/5/16" Tubing.....			●A63094
Aux. Cooler Hose.....		≡A63001		Aux. Cooler Inlet Tube Fitting (Pass. Side); W/4R70W Trans.;			
Aux. Cooler Outlet (Lower) .....	B61289			W/Super Cooling.....	A61017		
Inlet To Trans. (Upper) .....	B61288			Aux. Cooler Outlet (Driver Side); W/4R70W Trans.; W/Super			
Outlet From Rad. (Upper).....	B61281			Cooling .....	B61192		
<b>1997</b>				<b>By Pass Valve Washers (Front); W/4R100 Trans.....</b>			
<b>V-6 4.0 L ENG.</b>				<b>●A63105</b>			
"O" Ring (Connector & Fitting) .....			②A63090	<b>By Pass Valve Washers (Rear); W/4R100 Trans.....</b>			<b>●A63106</b>
Aux. Cooler Hose.....		≡A63001		<b>Inlet From Rad. (Lower); W/4R70W Trans.; W/O Aux. Cooler.....</b>	B61196		
Aux. Cooler Outlet (Lower) .....	B61279			<b>Inlet To Trans. (Rear); W/4R100 Trans.; W/Aux. Cooler; Under</b>			
Inlet From Rad. (Lower); W/O Aux. Cooler.....	B61277			<b>8500 G.V.W.....</b>	B61187		
Inlet To Trans. (Upper); W/Aux. Cooler.....	B61278			<b>Inlet To Trans. (Upper); W/4R70W Trans.; W/Super Cooling.....</b>	B61189		
Outlet To Trans. (Lower) .....	B61280			<b>Outlet From Rad. (Upper); W/4R100 Trans.....</b>	B61198		
<b>V-8 5.0 L ENG.</b>				<b>Outlet From Rad. (Upper); W/4R70W Trans.; W/Super Cooling .....</b>			
"O" Ring (Connector & Fitting) .....			②A63090		B61197		
Inlet From Rad. (Lower).....	B61183			<b>2001</b>			
Outlet From Rad. (Upper).....	B61184			<b>V-6 4.2 L ENG.; V-8 4.6 L ENG.</b>			
<b>1996</b>				<b>"O" Ring (Connector &amp; Fitting); W/3/8" Tubing .....</b>			
<b>V-6 4.0 L ENG.</b>				<b>●A63090</b>			
"O" Ring (Connector & Fitting) .....			●A63090	<b>"O" Ring (Connector &amp; Fitting); W/5/16" Tubing.....</b>			●A63094
Inlet Hose .....		≡A63001		Aux. Cooler Inlet Tube (Pass. Side); W/Super Cooling.....	A61017		
Inlet Tube .....		≡A63005		Aux. Cooler Outlet (Driver Side); W/Super Cooling.....	B61192		
Outlet Hose .....		≡A63001		<b>Inlet From Rad. (Lower); W/O Aux. Cooler; Under 8500 G.V.W. ....</b>	B61196		
Outlet Tube.....		≡A63005		<b>Inlet To Trans. (Upper); W/Super Cooling; Under 8500 G.V.W.....</b>	B61189		
<b>V-8 5.0 L ENG.</b>				<b>Outlet From Rad. (Upper); W/Super Cooling.....</b>			
"O" Ring (Connector & Fitting) .....			②A63090		B61197		
Inlet From Rad. (Lower).....	B61183			<b>V-8 5.4 L ENG.</b>			
Outlet From Rad. (Upper).....	B61184			"O" Ring (Connector & Fitting); W/3/8" Tubing .....			●A63090
<b>1995-1991</b>				<b>"O" Ring (Connector &amp; Fitting); W/5/16" Tubing.....</b>			
<b>V-6 4.0 L ENG.</b>				<b>●A63094</b>			
"O" Ring (Connector & Fitting) .....			●A63090	Aux. Cooler Inlet Tube (Pass. Side); W/4R70W Trans.;			
Inlet Hose .....		≡A63001		W/Super Cooling.....	A61017		
Inlet Tube .....		≡A63005		Aux. Cooler Outlet (Driver Side); W/4R70W Trans.; W/Super			
Outlet Hose .....		≡A63001		Cooling .....	B61192		
Outlet Tube.....		≡A63005		<b>By Pass Valve Washers (Front); W/4R100 Trans.....</b>			<b>●A63105</b>
Tube Nut To Trans. ....			②A63013	<b>By Pass Valve Washers (Rear); W/4R100 Trans.....</b>			<b>●A63106</b>
<b>EXPLORER SPORT TRAC</b>				<b>Inlet From Rad. (Lower); W/4R70W Trans.; W/O Aux. Cooler.....</b>			
<b>2002-2001</b>				<b>B61196</b>			
<b>V-6 4.0 L ENG.</b>				<b>●A63105</b>			
"O" Ring (Connector & Fitting) .....			②A63090	<b>Inlet To Trans. (Upper); W/4R100 Trans.; W/Super Cooling.....</b>	B61187		
Aux. Cooler Hose.....		≡A63001		<b>Outlet From Rad. (Upper); W/4R100 Trans.....</b>	B61198		
<b>F SERIES PICKUP</b>				<b>Outlet From Rad. (Upper); W/4R70W Trans.; W/Super Cooling .....</b>			
<b>2002</b>				<b>B61197</b>			
<b>V-6 4.2 L ENG.; V-8 4.6 L ENG.</b>				<b>●A63090</b>			
"O" Ring (Connector & Fitting) .....			●A63090	<b>2001</b>			
Aux. Cooler Inlet Tube Fitting (Pass. Side); W/Super Cooling....	A61017			<b>V-8 5.4 L ENG.</b>			
Aux. Cooler Outlet (Driver Side); W/Super Cooling.....	B61192			"O" Ring (Connector & Fitting); W/3/8" Tubing .....			●A63090
Inlet From Rad. (Lower); W/O Aux. Cooler; Under 8500 G.V.W.....	B61196			<b>"O" Ring (Connector &amp; Fitting); W/5/16" Tubing.....</b>			●A63094
Inlet To Trans. (Upper); W/Super Cooling; Under 8500 G.V.W.....	B61189			Aux. Cooler Inlet Tube (Pass. Side); W/4R70W Trans.;			
Outlet From Rad. (Upper); W/Super Cooling.....	B61197			W/Super Cooling.....	A61017		
<b>V-8 5.4 L ENG.</b>				<b>Aux. Cooler Outlet (Driver Side); W/4R70W Trans.; W/Super Cooling .....</b>			
"O" Ring (Connector & Fitting); W/3/8" Tubing .....			●A63090	<b>By Pass Valve Washers (Front); W/4R100 Trans.....</b>			<b>●A63105</b>
				<b>By Pass Valve Washers (Rear); W/4R100 Trans.....</b>			<b>●A63106</b>
				<b>Inlet From Rad. (Lower); W/4R70W Trans.; W/O Aux. Cooler.....</b>	B61196		
				<b>Inlet To Trans. (Rear); W/4R100 Trans.; W/Aux. Cooler; Under</b>			
				<b>8500 G.V.W.....</b>	B61187		
				<b>Inlet To Trans. (Upper); W/4R70W Trans.; W/Super Cooling.....</b>	B61189		
				<b>Outlet From Rad. (Upper); W/4R100 Trans.....</b>	B61198		
				<b>Outlet From Rad. (Upper); W/4R70W Trans.; W/Super Cooling .....</b>	B61197		

② Two Required.  
③ Three Required.

④ Four Required.  
⑤ Five Required.

⑥ Six Required.  
⑦ Seven Required.

≡ Cut To Fit.  
● As Required.

See Pages 1 - 10 for Engine Oil Cooler Applications.

# Transmission Oil Cooler Assemblies for Passenger Cars & Light Trucks

Application	Assembly Number	Hoses & Tubes	Connectors & Fittings	Application	Assembly Number	Hoses & Tubes	Connectors & Fittings
<b>FORD - Continued</b>				<b>FORD - Continued</b>			
<b>F SERIES PICKUP - Continued</b>				<b>F SERIES PICKUP - Continued</b>			
<b>2000</b>				<b>1999 - Continued</b>			
<b>V-6 4.2 L ENG.; V-8 4.6 L ENG.</b>				<b>V-8 5.4 L ENG. - Continued</b>			
"O" Ring (Connector & Fitting); W/3/8" Tubing .....			●A63090	By Pass Valve Washers (Rear); W/4R100 Trans. ....			●A63106
"O" Ring (Connector & Fitting); W/5/16" Tubing.....			●A63094	Inlet From Rad. (Lower); W/4R100 Trans.; Under 8500 G.V.W.....	B61196		
Aux. Cooler Inlet Tube Fitting (Pass. Side); W/Super Cooling....	A61017			Inlet From Rad. (Lower); W/4R100 Trans.; W/O Aux. Cooler .....	B61186		
Aux. Cooler Outlet (Driver Side); W/Super Cooling .....	B61192			Inlet From Rad. (Lower); W/4R70W Trans.; W/O Aux. Cooler .....	B61196		
Inlet From Rad. (Lower); W/O Aux. Cooler.....	B61196			Inlet To Trans. (Rear); W/4R100 Trans.; W/Aux. Cooler .....	B61187		
Inlet To Trans. (Upper); W/Super Cooling .....	B61189			Inlet To Trans. (Upper); W/4R70W Trans.; W/Aux. Cooler .....	B61189		
Outlet From Rad. (Upper); W/Super Cooling .....	B61197			Outlet From Rad. (Upper); W/4R100 Trans. ....	B61198		
<b>V-8 5.4 L ENG.</b>				<b>1998</b>			
"O" Ring (Connector & Fitting); W/3/8" Tubing .....			●A63090	<b>V-6 4.2 L ENG.; V-8 4.6 L ENG.</b>			●A63090
"O" Ring (Connector & Fitting); W/5/16" Tubing.....			●A63094	"O" Ring (Connector) .....			●A63094
Aux. Cooler Inlet Tube Fitting (Pass. Side); W/4R100 Trans.....	A61019			"O" Ring (Fitting) .....			
Aux. Cooler Inlet Tube Fitting (Pass. Side); W/4R70W Trans.; W/Super Cooling .....	A61017			Aux. Cooler Inlet Hose (Pass. Side) .....		≠A63000	
Aux. Cooler Outlet (Driver Side); W/4R70W Trans.; W/Super Cooling .....	B61192			Aux. Cooler Inlet Tube Fitting (Pass. Side).....	A61017		
By Pass Valve Washers (Front); W/4R100 Trans. ....			●A63105	Aux. Cooler Outlet (Driver Side).....	B61192		
By Pass Valve Washers (Rear); W/4R100 Trans. ....			●A63106	Inlet From Rad. (Lower); W/O Aux. Cooler .....	B61188		
Inlet From Rad. (Lower); W/4R100 Trans.; W/O Aux. Cooler .....	B61186			Inlet To Trans. (Upper); W/Aux. Cooler.....	B61189		
Inlet From Rad. (Lower); W/4R70W Trans.; W/O Aux. Cooler .....	B61196			Outlet From Rad. (Upper).....	B61191		
Inlet To Trans. (Rear); W/4R100 Trans.; W/Aux. Cooler; Under 8500 G.V.W.....	B61187			<b>V-8 5.4 L ENG.</b>			
Inlet To Trans. (Upper); W/4R70W Trans.; W/Super Cooling .....	B61189			"O" Ring (Connector & Fitting); W/3/8" Tubing .....			●A63090
Outlet From Rad. (Upper); W/4R100 Trans. ....	B61198			"O" Ring (Connector & Fitting); W/5/16" Tubing.....			●A63094
Outlet From Rad. (Upper); W/4R70W Trans.; W/Super Cooling .....	B61197			Aux. Cooler Inlet Hose (Pass. Side); W/4R70W Trans. ....		≠A63000	
<b>1999</b>				Aux. Cooler Inlet Tube Fitting (Pass. Side); W/4R100 Trans.....	A61019		
<b>V-6 4.2 L ENG.; V-8 4.6 L ENG.</b>				Aux. Cooler Inlet Tube Fitting (Pass. Side); W/4R70W Trans. ...	A61017		
"O" Ring (Connector) .....			●A63090	Aux. Cooler Outlet (Driver Side); W/4R100 Trans. ....	B61193		
"O" Ring (Fitting) .....	B61192		●A63094	Aux. Cooler Outlet (Driver Side); W/4R70W Trans. ....	B61192		
Aux. Cooler Outlet (Driver Side).....	B61196			By Pass Valve Washers (Front); W/4R100 Trans. ....			●A63105
Inlet From Rad. (Lower); W/O Aux. Cooler.....	B61196			By Pass Valve Washers (Rear); W/4R100 Trans. ....			●A63106
Inlet To Trans. (Upper); W/Aux. Cooler .....	B61189			Inlet From Rad. (Lower); W/4R100 Trans.; W/O Aux. Cooler .....	B61186		
Outlet From Rad. (Upper).....	B61197			Inlet From Rad. (Lower); W/4R70W Trans.; W/O Aux. Cooler .....	B61188		
<b>V-8 5.4 L ENG.</b>				Inlet To Trans. (Rear); W/4R100 Trans.; W/Aux. Cooler .....	B61187		
"O" Ring (Connector & Fitting); W/3/8" Tubing .....			●A63090	Inlet To Trans. (Upper); W/4R70W Trans.; W/Aux. Cooler .....	B61189		
"O" Ring (Connector & Fitting); W/5/16" Tubing.....			●A63094	Outlet From Rad. (Upper); W/4R100 Trans.; W/Aux. Cooler.	B61190		
Aux. Cooler Inlet Tube Fitting (Pass. Side); W/4R100 Trans.....	A61019			Outlet From Rad. (Upper); W/4R100 Trans.; W/O Aux. Cooler; Jan. 14 & Older .....	B61194		
Aux. Cooler Outlet (Driver Side); W/4R100 Trans. ....	B61193			Outlet From Rad. (Upper); W/4R100 Trans.; W/O Aux. Cooler; Jan. 15 & Newer .....	B61198		
Aux. Cooler Outlet (Driver Side); W/4R70W Trans. ....	B61192			Outlet From Rad. (Upper); W/4R70W Trans. ....	B61191		
By Pass Valve Washers (Front); W/4R100 Trans. ....			●A63105				

② Two Required.  
③ Three Required.

④ Four Required.  
⑤ Five Required.

⑥ Six Required.  
⑦ Seven Required.

≠ Cut To Fit.  
● As Required.

See Pages 1 - 10 for Engine Oil Cooler Applications.

## Transmission Oil Cooler Assemblies for Passenger Cars &amp; Light Trucks

Application	Assembly Number	Hoses & Tubes	Connectors & Fittings	Application	Assembly Number	Hoses & Tubes	Connectors & Fittings
<b>FORD - Continued</b>				<b>FORD - Continued</b>			
<b>F SERIES PICKUP - Continued</b>				<b>F SERIES PICKUP - Continued</b>			
<b>1997</b>				<b>1996-1990 - Continued</b>			
<b>V-6 4.2 L ENG.; V-8 4.6 L ENG.</b>				<b>6-CYL. 4.9 L ENG.; V-8 5.0 L ENG.; V-8 5.8 L ENG.; V-8 7.3 L DIESEL ENG.; V-8 7.5 L ENG. - Continued</b>			
"O" Ring (Connector & Fitting).....			●A63094	Inlet Hose .....		≡A63000	
Aux. Cooler Inlet Hose (Pass. Side).....		≡A63000		Inlet Tube .....		≡A63004	
Aux. Cooler Inlet Tube Fitting (Pass. Side).....	A61017			Outlet Hose .....		≡A63000	
Aux. Cooler Outlet (Driver Side).....	B61192			Outlet Tube.....		≡A63004	
Connector From Rad.; W/1/4" Male Pipe Thread.....			ⓄA63050	Tube Nut From Rad.....			ⓄA63047
Inlet From Rad. (Lower); W/O Aux. Cooler.....	B61188			Tube Nut To Trans. ....			ⓄA63011
Inlet To Trans. (Upper); W/Aux. Cooler.....	B61189			<b>LTD CROWN VICTORIA</b>			
Outlet From Rad. (Upper).....	B61191			<b>1991-1989</b>			
<b>V-8 5.4 L ENG.</b>				<b>V-8 5.0 L ENG.; V-8 5.8 L ENG.</b>			
"O" Ring (Connector & Fitting); W/3/8" Tubing .....			●A63090	"O" Ring (Connector & Fitting).....			●A63094
"O" Ring (Connector & Fitting); W/5/16" Tubing.....			●A63094	Connector From Rad. ....			ⓄA63050
Aux. Cooler Inlet Hose (Pass. Side); W/4R70W Trans. ....		≡A63000		Inlet Hose .....		≡A63000	
Aux. Cooler Inlet Tube Fitting (Pass. Side); W/4R70W Trans. ....	A61017			Inlet Tube .....		≡A63004	
Aux. Cooler Inlet Tube Fitting (Pass. Side); W/E4OD Trans. ....	A61019			Outlet Hose .....		≡A63000	
Aux. Cooler Outlet (Driver Side); W/4R70W Trans.....	B61192			Outlet Tube.....		≡A63004	
Aux. Cooler Outlet (Driver Side); W/E4OD Trans.....	B61193			Tube Nut From Rad.....			ⓄA63047
By Pass Valve Washers (Front); W/E4OD Trans.....			●A63105	Tube Nut To Trans. ....			ⓄA63011
By Pass Valve Washers (Rear); W/E4OD Trans.....			●A63106	<b>1988</b>			
Inlet From Rad. (Lower); W/4R70W Trans.; W/O Aux. Cooler.....	B61188			<b>V-8 5.0 L ENG.; V-8 5.8 L ENG.</b>			
Inlet From Rad. (Lower); W/E4OD Trans.; W/O Aux. Cooler.....	B61186			"O" Ring (Connector).....			ⓄA63094
Inlet To Trans. (Rear); W/E4OD Trans.; W/Aux. Cooler .....	B61187			"O" Ring (Fitting); Apr. 18 & Newer Connector From Rad. ....			ⓄA63094
Inlet To Trans. (Upper); W/4R70W Trans.; W/Aux. Cooler .....	B61189			Inlet Fitting To Trans.; Apr. 17 & Older.....			ⓄA63050
Outlet From Rad. (Upper); W/4R70W Trans.....	B61191			Inlet Hose .....		≡A63000	A63049
Outlet From Rad. (Upper); W/E4OD Trans.; W/Aux. Cooler..	B61190			Inlet Tube .....		≡A63004	
Outlet From Rad. (Upper); W/E4OD Trans.; W/O Aux. Cooler.....	B61194			Outlet Fitting To Trans.; Apr. 17 & Older.....			A63049
<b>V-8 5.8 L ENG.; V-8 7.3 L DIESEL ENG.; V-8 7.5 L ENG.</b>				<b>1988</b>			
"O" Ring (Connector & Fitting).....			●A63090	Outlet Hose .....		≡A63000	
Aux. Cooler Inlet Tube Fitting (Pass. Side).....	A61019			Outlet Tube.....		≡A63004	
Aux. Cooler Outlet (Driver Side).....	B61193			Tube Nut From Rad.....			ⓄA63047
By Pass Valve Washers (Front).....			●A63105	Tube Nut To Trans. ....			ⓄA63011
By Pass Valve Washers (Rear).....			●A63106	<b>MUSTANG</b>			
Inlet From Rad. (Lower).....	B61186			<b>2002-2001</b>			
Inlet To Trans. (Rear); W/Aux. Cooler.....	B61187			<b>V-6 3.8 L ENG.; V-8 4.6 L ENG.</b>			
Outlet From Rad. (Upper); W/Aux. Cooler.....	B61190			"O" Ring (Connector & Fitting).....			●A63094
Outlet From Rad. (Upper); W/O Aux. Cooler.....	B61194			Connector From Rad. ....			ⓄA63050
<b>1996-1990</b>				<b>2000-1997</b>			
<b>6-CYL. 4.9 L ENG.; V-8 5.0 L ENG.; V-8 5.8 L ENG.; V-8 7.3 L DIESEL ENG.; V-8 7.5 L ENG.</b>				<b>V-6 3.8 L ENG.; V-8 4.6 L ENG.</b>			
"O" Ring (Connector & Fitting).....			●A63094	"O" Ring (Connector & Fitting).....			●A63094
Aux. Cooler Hose.....		≡A63000		Aux. Cooler Inlet Hose.....		≡A63000	
Aux. Cooler Tube.....		≡A63004		Aux. Cooler Outlet Hose.....		≡A63000	
Connector From Rad. ....			ⓄA63050	Connector From Rad. ....			ⓄA63050
<b>1996</b>				<b>1996</b>			
<b>V-6 3.8 L ENG.</b>				<b>V-6 3.8 L ENG.</b>			
"O" Ring (Connector & Fitting).....				"O" Ring (Connector & Fitting).....			●A63094
Aux. Cooler Inlet Hose.....				Aux. Cooler Inlet Hose.....		≡A63000	
Aux. Cooler Outlet Hose.....				Aux. Cooler Outlet Hose.....		≡A63000	
Connector From Rad. ....				Connector From Rad. ....			ⓄA63050
Inlet Hose .....				Inlet Hose .....		≡A63000	
Inlet Tube .....				Inlet Tube .....		≡A63004	
Outlet Hose .....				Outlet Hose .....		≡A63000	
Outlet Tube.....				Outlet Tube.....		≡A63004	
Tube Nut From Rad.....				Tube Nut From Rad.....			ⓄA63047
Tube Nut To Trans. ....				Tube Nut To Trans. ....			ⓄA63011
<b>1995</b>				<b>1995</b>			
<b>V-6 3.8 L ENG.; V-8 5.0 L ENG.; V-8 5.8 L ENG.</b>				<b>V-6 3.8 L ENG.; V-8 5.0 L ENG.; V-8 5.8 L ENG.</b>			
"O" Ring (Connector & Fitting).....				"O" Ring (Connector & Fitting).....			●A63094
Aux. Cooler Inlet Hose.....				Aux. Cooler Inlet Hose.....		≡A63000	

② Two Required.  
③ Three Required.

④ Four Required.  
⑤ Five Required.

⑥ Six Required.  
⑦ Seven Required.

≡ Cut To Fit.  
● As Required.

See Pages 1 - 10 for Engine Oil Cooler Applications.



## Transmission Oil Cooler Assemblies for Passenger Cars & Light Trucks

Application	Assembly Number	Hoses & Tubes	Connectors & Fittings	Application	Assembly Number	Hoses & Tubes	Connectors & Fittings
<b>FORD - Continued</b>				<b>FORD - Continued</b>			
<b>MUSTANG - Continued</b>				<b>MUSTANG - Continued</b>			
<b>1995 - Continued</b>				<b>1989 - Continued</b>			
<b>V-6 3.8 L ENG.; V-8 5.0 L ENG.; V-8 5.8 L ENG. - Continued</b>				<b>4-CYL. 2.3 L ENG.; V-8 5.0 L ENG. - Continued</b>			
Aux. Cooler Outlet Hose.....		④-A63000		Connector From Rad.; W/5/16" Tubing.....			② A63050
Connector From Rad. ....			② A63050	Inlet Hose; W/4-Speed Trans. ....	④-A63001		
Inlet Hose .....		④-A63000		Inlet Hose; W/Auto. Overdrive Trans. ....		④-A63000	
Inlet Tube .....		④-A63004		Inlet Tube; W/4-Speed Trans. ....		④-A63005	
Outlet Hose .....		④-A63000		Inlet Tube; W/Auto. Overdrive Trans. ....		④-A63004	
Outlet Tube.....		④-A63004		Outlet Hose; W/4-Speed Trans. ....		④-A63001	
Tube Nut From Rad.....			② A63047	Outlet Hose; W/Auto. Overdrive Trans. ....		④-A63000	
Tube Nut To Trans. ....			② A63011	Outlet Tube; W/4-Speed Trans.....		④-A63005	
				Outlet Tube; W/Auto. Overdrive Trans. ....		④-A63004	
				Tube Nut From Rad.; W/5/16" Tubing.....			② A63047
				Tube Nut To Trans.; W/5/16" Tubing.....			② A63011
<b>1994</b>				<b>1988</b>			
<b>V-6 3.8 L ENG.; V-8 5.0 L ENG.</b>				<b>4-CYL. 2.3 L ENG.</b>			
"O" Ring (Connector & Fitting) .....			● A63094	"O" Ring (Connector & Fitting); W/Auto. Overdrive Trans. ....			● A63094
Aux. Cooler Inlet Hose.....		④-A63000		Connector From Rad. ....			② A63050
Aux. Cooler Outlet Hose.....		④-A63000		Inlet Fitting To Trans.; W/Auto. Overdrive Trans.; Apr. 17 & Older.....			A63049
Connector From Rad. ....			② A63050	Inlet Hose; W/4-Speed Trans. ....		④-A63001	
Inlet Hose .....		④-A63000		Inlet Hose; W/Auto. Overdrive Trans. ....		④-A63000	
Inlet Tube .....		④-A63004		Inlet Tube; W/4-Speed Trans. ....		④-A63005	
Outlet Hose .....		④-A63000		Inlet Tube; W/Auto. Overdrive Trans. ....		④-A63004	
Outlet Tube.....		④-A63004		Outlet Fitting To Trans.; W/Auto. Overdrive Trans.; Apr. 17 & Older.....			A63049
Tube Nut From Rad.....			② A63047	Outlet Hose; W/4-Speed Trans. ....		④-A63001	
Tube Nut To Trans. ....			② A63011	Outlet Hose; W/Auto. Overdrive Trans. ....		④-A63000	
				Outlet Tube; W/4-Speed Trans.....		④-A63005	
				Outlet Tube; W/Auto. Overdrive Trans. ....		④-A63004	
				Tube Nut From Rad.; W/5/16" Tubing.....			② A63047
				Tube Nut To Trans.; W/5/16" Tubing.....			② A63011
<b>1993</b>				<b>PROBE</b>			
<b>4-CYL. 2.3 L ENG.; V-8 5.0 L ENG.</b>				<b>1997-1993</b>			
"O" Ring (Connector & Fitting); W/Auto. Overdrive Trans. ....			● A63094	<b>4-CYL. 2.0 L ENG.; V-6 2.5 L ENG.</b>			
Connector From Rad.; W/5/16" Tubing.....			② A63050	"O" Ring (Fitting) .....			② A63090
Inlet Hose; W/4-Speed Trans. ....		④-A63001		Banjo Washers; W/14mm I.D. Banjo.....			● A63103
Inlet Hose; W/Auto. Overdrive Trans. ....		④-A63000		Banjo Washers; W/16mm I.D. Banjo.....			● A63104
Inlet Tube; W/4-Speed Trans. ....		④-A63005					
Inlet Tube; W/AOD Trans. ....		④-A63004					
Outlet Hose; W/4-Speed Trans. ....		④-A63001					
Outlet Hose; W/Auto. Overdrive Trans. ....		④-A63000					
Outlet Tube; W/4-Speed Trans.....		④-A63005					
Outlet Tube; W/Auto. Overdrive Trans. ....		④-A63004					
Tube Nut From Rad.; W/5/16" Tubing.....			② A63047				
Tube Nut To Trans.; W/5/16" Tubing.....			② A63011				
<b>1992-1990</b>				<b>1992-1990</b>			
<b>4-CYL. 2.3 L ENG.; V-8 5.0 L ENG.</b>				<b>4-CYL. 2.2 L ENG.</b>			
"O" Ring (Connector & Fitting); W/AOD Trans. ....			● A63094	Banjo Washers; W/12mm I.D. Banjo.....			● A63100
Connector From Rad.; W/5/16" Tubing.....			② A63050	Banjo Washers; W/16mm I.D. Banjo.....			● A63104
Inlet Hose; W/4-Speed Trans. ....		④-A63001					
Inlet Hose; W/AOD Trans. ....		④-A63000					
Inlet Tube; W/4-Speed Trans. ....		④-A63005					
Inlet Tube; W/AOD Trans. ....		④-A63004					
Outlet Hose; W/4-Speed Trans. ....		④-A63001					
Outlet Hose; W/AOD Trans. ....		④-A63000					
Outlet Tube; W/4-Speed Trans.....		④-A63005					
Outlet Tube; W/AOD Trans. ....		④-A63004					
Tube Nut From Rad.; W/5/16" Tubing.....			② A63047				
Tube Nut To Trans.; W/5/16" Tubing.....			② A63011				
<b>1989</b>				<b>RANGER</b>			
<b>4-CYL. 2.3 L ENG.; V-8 5.0 L ENG.</b>				<b>2003-2002</b>			
"O" Ring (Connector & Fitting); W/Auto. Overdrive Trans. ....			● A63094	<b>4-CYL. 2.3 L ENG.</b>			
				"O" Ring (Connector & Fitting) .....			● A63090

② Two Required.  
③ Three Required.

④ Four Required.  
⑤ Five Required.

⑥ Six Required.  
⑦ Seven Required.

✂ Cut To Fit.  
● As Required.

See Pages 1 - 10 for Engine Oil Cooler Applications.

## Transmission Oil Cooler Assemblies for Passenger Cars &amp; Light Trucks

Application	Assembly Number	Hoses & Tubes	Connectors & Fittings	Application	Assembly Number	Hoses & Tubes	Connectors & Fittings
<b>FORD - Continued</b>				<b>FORD - Continued</b>			
<b>RANGER - Continued</b>				<b>RANGER - Continued</b>			
<b>2003-2002 - Continued</b>				<b>2000-1998 - Continued</b>			
<b>V-6 3.0 L ENG.</b>				<b>V-6 4.0 L ENG. - Continued</b>			
"O" Ring (Connector & Fitting) .....			●A63090	Aux. Cooler Inlet Hose (Pass. Side) .....		≡A63001	
Aux. Cooler Inlet Hose (Pass. Side) .....		≡A63001		Aux. Cooler Outlet Hose (Driver Side) .....		≡A63001	
Aux. Cooler Outlet Hose (Driver Side) .....		≡A63001		Aux. Cooler Outlet Tube (Lower) ...	B61279		
Inlet To Trans. (Upper) .....	B61279			Inlet To Trans. (Upper); W/Aux. Cooler .....	B61278		
Outlet To Trans. (Lower) .....	B61286			Inlet To Trans. (Upper); W/O Aux. Cooler .....	B61277		
	B61287			Outlet To Trans. (Lower) .....	B61280		
<b>V-6 4.0 L ENG.</b>				<b>1997-1993</b>			
"O" Ring (Connector & Fitting) .....			●A63090	<b>4-CYL. 2.3 L ENG.; V-6 3.0 L ENG.; V-6 4.0 L ENG.</b>			
Aux. Cooler Inlet Hose (Pass. Side) .....		≡A63001		"O" Ring (Connector & Fitting) .....			●A63090
Aux. Cooler Outlet Hose (Driver Side) .....		≡A63001		Inlet Tube .....		≡A63005	
Aux. Cooler Outlet Tube (Lower) ...	B61279			Outlet Tube .....		≡A63005	
Inlet To Trans. (Upper); W/Aux. Cooler .....	B61278			Tube Nut To Trans. ....			ⓄA63013
Inlet To Trans. (Upper); W/O Aux. Cooler .....	B61277			<b>1992-1991</b>			
Outlet To Trans. (Lower) .....	B61280			<b>4-CYL. 2.3 L ENG.; V-6 2.9 L ENG.; V-6 3.0 L ENG.; V-6 4.0 L ENG.</b>			
<b>2001</b>				<b>1990</b>			
<b>4-CYL. 2.3 L ENG.</b>				<b>4-CYL. 2.3 L ENG.; V-6 2.9 L ENG.; V-6 4.0 L ENG.</b>			
"O" Ring (Connector & Fitting) .....			●A63090	"O" Ring (Connector & Fitting) .....			●A63090
4-CYL. 2.5 L ENG.			●A63090	Inlet Tube .....		≡A63005	
"O" Ring (Connector & Fitting) .....			●A63090	Outlet Tube .....		≡A63005	
Inlet To Trans. (Upper) .....	B61291			Tube Nut To Trans. ....			ⓄA63013
Outlet To Trans. (Lower) .....	B61290			<b>1989</b>			
<b>V-6 3.0 L ENG.</b>				<b>4-CYL. 2.3 L ENG.; V-6 2.9 L ENG.</b>			
"O" Ring (Connector & Fitting) .....			●A63090	"O" Ring (Connector & Fitting) .....			●A63090
Aux. Cooler Inlet Hose (Pass. Side) .....		≡A63001		Inlet Tube .....		≡A63005	
Aux. Cooler Outlet Hose (Driver Side) .....		≡A63001		Outlet Tube .....		≡A63005	
Aux. Cooler Outlet Tube (Lower) ...	B61279			Tube Nut To Trans. ....			ⓄA63013
Inlet To Trans. (Upper) .....	B61286			<b>1988</b>			
Outlet To Trans. (Lower) .....	B61287			<b>4-CYL. 2.0 L ENG.; 4-CYL. 2.3 L ENG.; V-6 2.9 L ENG.</b>			
<b>V-6 4.0 L ENG.</b>				<b>4-CYL. 2.0 L ENG.; 4-CYL. 2.3 L ENG.; V-6 2.9 L ENG.</b>			
"O" Ring (Connector & Fitting) .....			●A63090	"O" Ring (Connector & Fitting) .....			●A63090
Aux. Cooler Inlet Hose (Pass. Side) .....		≡A63001		Inlet Tube .....		≡A63005	
Aux. Cooler Outlet Hose (Driver Side) .....		≡A63001		Outlet Tube .....		≡A63005	
Aux. Cooler Outlet Tube (Lower) ...	B61279			Tube Nut To Trans. ....			ⓄA63013
Inlet To Trans. (Upper); W/Aux. Cooler .....	B61278			<b>SUPER DUTY PICKUP</b>			
Inlet To Trans. (Upper); W/O Aux. Cooler .....	B61277			<b>2002</b>			
Outlet To Trans. (Lower) .....	B61280			<b>V-8 5.4 L ENG.; V-10 6.8 L ENG.</b>			
<b>2000-1998</b>				<b>"O" Ring (Connector) .....</b>			
<b>4-CYL. 2.5 L ENG.</b>				●A63090			
"O" Ring (Connector & Fitting) .....			●A63090	Aux. Cooler Inlet Hose (Upper) .....		≡A63001	
Inlet To Trans. (Upper) .....	B61291			Aux. Cooler Outlet Hose (Lower) ...		≡A63001	
Outlet To Trans. (Lower) .....	B61290			By Pass Valve Washers (Front) .....			●A63105
<b>V-6 3.0 L ENG.</b>				●A63106			
"O" Ring (Connector & Fitting) .....			●A63090	By Pass Valve Washers (Rear) .....			
Aux. Cooler Inlet Hose (Pass. Side) .....		≡A63001		Inlet To Trans. (Rear) .....	B61047		
Aux. Cooler Outlet Hose (Driver Side) .....		≡A63001		Outlet To Trans. (Front) .....	B61100		
Aux. Cooler Outlet Tube (Lower) ...	B61279			<b>V-8 7.3 L DIESEL ENG.</b>			
Inlet To Trans. (Upper) .....	B61286			<b>"O" Ring (Connector) .....</b>			
Outlet To Trans. (Lower) .....	B61287			●A63090			
<b>V-6 4.0 L ENG.</b>				Aux. Cooler Inlet Hose (Upper) .....			
"O" Ring (Connector & Fitting) .....			●A63090	≡A63001			
Aux. Cooler Inlet Hose (Pass. Side) .....		≡A63001		Aux. Cooler Outlet Hose (Lower) ...			
Aux. Cooler Outlet Hose (Driver Side) .....		≡A63001		By Pass Valve Washers (Front);			
Aux. Cooler Outlet Tube (Lower) ...	B61279			W/535 I.D. Washer .....			
Inlet To Trans. (Upper) .....	B61286			●A63105			
Outlet To Trans. (Lower) .....	B61287			By Pass Valve Washers (Rear);			
<b>V-6 4.0 L ENG.</b>				W/668 I.D. Washer .....			
"O" Ring (Connector & Fitting) .....			●A63090	●A63106			
				Inlet To Trans. (Rear) .....			
				B61283			

Ⓞ Two Required.  
Ⓜ Three Required.

Ⓠ Four Required.  
Ⓡ Five Required.

Ⓢ Six Required.  
Ⓣ Seven Required.

≡ Cut To Fit.  
● As Required.

See Pages 1 - 10 for Engine Oil Cooler Applications.



## Transmission Oil Cooler Assemblies for Passenger Cars &amp; Light Trucks

Application	Assembly Number	Hoses & Tubes	Connectors & Fittings	Application	Assembly Number	Hoses & Tubes	Connectors & Fittings
<b>FORD - Continued</b>				<b>FORD - Continued</b>			
<b>SUPER DUTY VAN - Continued</b>				<b>SUPER DUTY VAN - Continued</b>			
<b>2003 - Continued</b>				<b>2001</b>			
<b>V-8 4.6 L ENG. - Continued</b>				<b>V-6 4.2 L ENG.</b>			
Connector From Rad.; W/1/4" Male				"O" Ring (Connector & Fitting).....			●A63094
Pipe Thread.....			●A63050	Aux. Cooler Inlet Hose (Driver			
Inlet (Upper).....	B61307			Side).....	≠A63000		
Outlet (Lower).....	B61309			Aux. Cooler Outlet Hose (Pass.			
				Side).....	≠A63000		
<b>V-8 5.4 L ENG.</b>				<b>V-8 5.4 L ENG.</b>			
"O" Ring (Connector & Fitting).....			●A63094	"O" Ring (Connector & Fitting).....			●A63094
Aux. Cooler Inlet Hose (Driver				Aux. Cooler Inlet Hose (Driver			
Side).....	≠A63001			Side).....	≠A63001		
Aux. Cooler Outlet Hose (Pass.				Connector From Rad.; W/1/4" Male			
Side).....	≠A63001			Pipe Thread.....			●A63050
By Pass Valve Washers (Front);				Inlet (Upper).....	B61308		
W/4R100 Trans.....			●A63105				
By Pass Valve Washers (Rear);				<b>V-8 5.4 L ENG.</b>			
W/4R100 Trans.....			●A63106	"O" Ring (Connector & Fitting).....			●A63094
Connector From Rad.; W/1/4" Male				Aux. Cooler Inlet Hose (Driver			
Pipe Thread.....			⊗A63050	Side).....	≠A63001		
Inlet To Trans. (Rear); W/4R100				Aux. Cooler Outlet Hose (Pass.			
Trans.....	B61306			Side).....	≠A63001		
Outlet To Trans. (Front); W/4R100				By Pass Valve Washers (Front);			●A63105
Trans.....	B61310			W/4R100 Trans.....			●A63106
				By Pass Valve Washers (Rear);			
<b>V-8 7.3 L DIESEL ENG.; V-10 6.8 L ENG.</b>				<b>V-8 7.3 L DIESEL ENG.; V-10 6.8 L ENG.</b>			
"O" Ring (Connector & Fitting).....			●A63094	Connector From Rad.; W/1/4" Male			⊗A63050
Aux. Cooler Inlet Hose (Driver				Pipe Thread.....			
Side).....	≠A63001			Inlet To Trans. (Rear); W/4R100			
Aux. Cooler Outlet Hose (Pass.				Trans.....	B61306		
Side).....	≠A63001			Outlet To Trans. (Front); W/4R100			
By Pass Valve Washers (Front).....			●A63105	Trans.....	B61310		
By Pass Valve Washers (Rear).....			●A63106				
Connector From Rad.; W/1/4" Male				<b>V-8 7.3 L DIESEL ENG.; V-10 6.8 L ENG.</b>			
Pipe Thread.....			⊗A63050	"O" Ring (Connector).....			●A63094
				Aux. Cooler Inlet Hose (Driver			
<b>2002</b>				<b>V-8 5.4 L ENG.</b>			
<b>V-6 4.2 L ENG.</b>				<b>V-8 5.4 L ENG.</b>			
"O" Ring (Connector & Fitting).....			●A63094	"O" Ring (Connector & Fitting).....			●A63094
Aux. Cooler Inlet Hose (Driver				Aux. Cooler Inlet Hose (Driver			
Side).....	≠A63000			Side).....	≠A63001		
Aux. Cooler Outlet Hose (Pass.				Aux. Cooler Outlet Hose (Pass.			
Side).....	≠A63000			Side).....	≠A63001		
Connector From Rad.; W/1/4" Male				By Pass Valve Washers (Front);			●A63105
Pipe Thread.....			●A63050	W/4R100 Trans.....			●A63106
Inlet (Upper).....	B61308			By Pass Valve Washers (Rear);			
				W/4R100 Trans.....			⊗A63050
<b>V-8 5.4 L ENG.</b>				<b>V-8 5.4 L ENG.</b>			
"O" Ring (Connector & Fitting).....			●A63094	Connector From Rad.; W/1/4" Male			⊗A63050
Aux. Cooler Inlet Hose (Driver				Pipe Thread.....			
Side).....	≠A63001			Inlet To Trans. (Rear); W/4R100			
Aux. Cooler Outlet Hose (Pass.				Trans.....	B61306		
Side).....	≠A63001			Outlet To Trans. (Front); W/4R100			
By Pass Valve Washers (Front);			●A63105	Trans.....	B61310		
W/4R100 Trans.....			●A63106				
By Pass Valve Washers (Rear);				<b>V-8 7.3 L DIESEL ENG.; V-10 6.8 L ENG.</b>			
W/4R100 Trans.....			⊗A63050	"O" Ring (Connector).....			●A63094
Connector From Rad.; W/1/4" Male				Aux. Cooler Inlet Hose (Driver			
Pipe Thread.....				Side).....	≠A63001		
Inlet To Trans. (Rear); W/4R100				Aux. Cooler Outlet Hose (Pass.			
Trans.....	B61306			Side).....	≠A63001		
Outlet To Trans. (Front); W/4R100				By Pass Valve Washers (Front).....			●A63105
Trans.....	B61310			By Pass Valve Washers (Rear).....			●A63106
				Connector From Rad.; W/1/4" Male			⊗A63050
<b>V-8 7.3 L DIESEL ENG.; V-10 6.8 L ENG.</b>				<b>V-8 7.3 L DIESEL ENG.; V-10 6.8 L ENG.</b>			
"O" Ring (Connector & Fitting).....			●A63094	Pipe Thread.....			
Aux. Cooler Inlet Hose (Driver							
Side).....	≠A63001			<b>1998</b>			
Aux. Cooler Outlet Hose (Pass.				<b>V-8 5.4 L ENG.</b>			
Side).....	≠A63001			<b>V-8 5.4 L ENG.</b>			
By Pass Valve Washers (Front).....			●A63105	"O" Ring (Connector).....			●A63094
By Pass Valve Washers (Rear).....			●A63106	Aux. Cooler Inlet Hose (Driver			
Connector From Rad.; W/1/4" Male				Side).....	≠A63001		
Pipe Thread.....			⊗A63050				

② Two Required.  
③ Three Required.

④ Four Required.  
⑤ Five Required.

⑥ Six Required.  
⑦ Seven Required.

≠ Cut To Fit.  
● As Required.

See Pages 1 - 10 for Engine Oil Cooler Applications.

# Transmission Oil Cooler Assemblies for Passenger Cars & Light Trucks

Application	Assembly Number	Hoses & Tubes	Connectors & Fittings	Application	Assembly Number	Hoses & Tubes	Connectors & Fittings
<b>FORD - Continued</b>				<b>FORD - Continued</b>			
<b>SUPER DUTY VAN - Continued</b>				<b>TAURUS - Continued</b>			
<b>1998 - Continued</b>				<b>1999 - Continued</b>			
<b>V-8 5.4 L ENG. - Continued</b>				<b>V-8 3.4 L ENG. - Continued</b>			
Aux. Cooler Outlet Hose (Pass. Side).....			✂-A63001	Outlet Fitting To Trans.....			A63076
By Pass Valve Washers (Front); W/E4OD/4R100 Trans.....			●A63105				
By Pass Valve Washers (Rear); W/E4OD/4R100 Trans.....			●A63106				
Connector From Rad.; W/1/4" Male Pipe Thread.....			②A63050				
Inlet (Upper); W/4R70W Trans.....	B61307						
Inlet To Trans. (Rear); W/E4OD/4R100 Trans.....	B61306						
Outlet To Trans. (Front); W/E4OD/4R100 Trans.....	B61310						
<b>V-8 7.3 L DIESEL ENG.; V-10 6.8 L ENG.</b>				<b>1998-1997</b>			
"O" Ring (Connector).....			●A63094	<b>V-6 3.0 L ENG.</b>			
Aux. Cooler Inlet Hose (Driver Side).....			✂-A63001	Inlet (Upper); W/Aux. Cooler; W/AX4N Trans.....	A61014		
Aux. Cooler Outlet Hose (Pass. Side).....			✂-A63001	Inlet Fitting To Trans.....			A63076
By Pass Valve Washers (Front).....			●A63105	Outlet (Lower); W/Aux. Cooler; W/AX4N Trans.....	A61069		
By Pass Valve Washers (Rear).....			●A63106	Outlet (Lower); W/Aux. Cooler; W/AX4S Trans.....	A61071		
Connector From Rad.; W/1/4" Male Pipe Thread.....			②A63050	Outlet Fitting To Trans.....			A63076
<b>1997</b>				<b>V-8 3.4 L ENG.</b>			
<b>V-8 5.4 L ENG.</b>				Inlet (Upper).....			
"O" Ring (Connector).....			●A63094	Inlet Fitting To Trans.....	A61014		A63076
Aux. Cooler Inlet Hose (Driver Side).....			✂-A63001	Outlet (Lower).....	A61069		A63076
Aux. Cooler Outlet Hose (Pass. Side).....			✂-A63001	Outlet Fitting To Trans.....			A63076
By Pass Valve Washers (Front); W/E4OD Trans.....			●A63105				
By Pass Valve Washers (Rear); W/E4OD Trans.....			●A63106				
Connector From Rad.; W/1/4" Male Pipe Thread.....			②A63050				
Inlet (Upper); W/4R70W Trans.....	B61307						
Inlet To Trans. (Rear); W/E4OD/4R100 Trans.....	B61306						
Outlet To Trans. (Front); W/E4OD/4R100 Trans.....	B61310						
<b>V-8 7.3 L DIESEL ENG.; V-10 6.8 L ENG.</b>				<b>1996</b>			
"O" Ring (Connector).....			●A63094	<b>V-6 3.0 L ENG.</b>			
Aux. Cooler Inlet Hose (Driver Side).....			✂-A63001	Inlet (Lower); W/O Aux. Cooler; W/AX4S Trans.....	B61046		
Aux. Cooler Outlet Hose (Pass. Side).....			✂-A63001	Inlet (Upper); W/Aux. Cooler; W/AX4S Trans.....	A61070		
By Pass Valve Washers (Front); W/E4OD Trans.....			●A63105	Inlet Fitting To Trans.....			A63076
By Pass Valve Washers (Rear); W/E4OD Trans.....			●A63106	Outlet (Lower); W/Aux. Cooler; W/AX4N Trans.....	A61069		
Connector From Rad.; W/1/4" Male Pipe Thread.....			②A63050	Outlet (Lower); W/Aux. Cooler; W/AX4S Trans.....	A61071		
Inlet (Upper); W/4R70W Trans.....	B61307			Outlet (Upper); W/O Aux. Cooler; W/AX4S Trans.....	B61013		
Inlet To Trans. (Rear); W/E4OD/4R100 Trans.....	B61306			Outlet Fitting To Trans.....			A63076
Outlet To Trans. (Front); W/E4OD/4R100 Trans.....	B61310						
<b>V-8 3.4 L ENG.</b>				<b>V-8 3.4 L ENG.</b>			
Inlet Fitting To Trans.....			A63076	Inlet Fitting To Trans.....	A61069		A63076
Outlet Fitting To Trans.....			A63076	Outlet (Lower).....			A63076
				Outlet Fitting To Trans.....			A63076
<b>TAURUS</b>				<b>1995-1993</b>			
<b>2003-2000</b>				<b>V-6 3.0 L ENG.</b>			
<b>V-6 3.0 L ENG.</b>				"O" Ring (Connector).....			
Inlet Fitting To Trans.....			A63076	Aux. Cooler Supply Hose.....			✂-A63000 ●A63094
Outlet Fitting To Trans.....			A63076	Aux. Cooler Supply Tube (Lower)...	B61178		②A63050
				Connector From Rad. ....			A63049
				Inlet Fitting To Trans.....			A63049
				Outlet Fitting To Trans.....			A63049
<b>1999</b>				<b>V-6 3.2 L ENG.</b>			
<b>V-6 3.0 L ENG.</b>				"O" Ring (Connector).....			
Inlet Fitting To Trans.....			A63076	Inlet Fitting To Trans.....			②A63090
Outlet Fitting To Trans.....			A63076	Outlet Fitting To Trans.....			A63049
				Outlet Fitting To Trans.....			A63049
<b>V-8 3.4 L ENG.</b>				<b>V-6 3.8 L ENG.</b>			
Inlet (Upper).....	A61014			"O" Ring (Connector).....			●A63094
Inlet Fitting To Trans.....			A63076	Aux. Cooler Supply Hose; W/Police Pkg. ....			✂-A63000
Outlet (Lower).....	A61069			Aux. Cooler Supply Tube (Lower); W/Police Pkg.....	B61178		
				Connector From Rad. ....			②A63050
				Inlet Fitting To Trans.....			A63049
				Outlet Fitting To Trans.....			A63049
				<b>1992</b>			
				<b>V-6 3.0 L ENG.</b>			
				"O" Ring (Connector).....			●A63094
				Connector From Rad. ....			②A63050
				Inlet Fitting To Trans.....			A63049
				Outlet Fitting To Trans.....			A63049
				<b>V-6 3.8 L ENG.</b>			
				"O" Ring (Connector).....			●A63094

② Two Required.  
③ Three Required.

④ Four Required.  
⑤ Five Required.

⑥ Six Required.  
⑦ Seven Required.

✂ Cut To Fit.  
● As Required.

See Pages 1 - 10 for Engine Oil Cooler Applications.

## Transmission Oil Cooler Assemblies for Passenger Cars &amp; Light Trucks

Application	Assembly Number	Hoses & Tubes	Connectors & Fittings	Application	Assembly Number	Hoses & Tubes	Connectors & Fittings
<b>FORD - Continued</b>				<b>FORD - Continued</b>			
<b>TAURUS - Continued</b>				<b>TAURUS - Continued</b>			
<b>1992 - Continued</b>				<b>1987-1986 - Continued</b>			
<b>V-6 3.8 L ENG. - Continued</b>				<b>4-CYL. 2.5 L ENG.; V-6 3.0 L ENG. - Continued</b>			
Aux. Cooler Supply Hose; W/Police Pkg.....		≡A63000		Tube Nut To Trans.; Service Item...			ⓐA63011
Aux. Cooler Supply Tube (Lower); W/Police Pkg.....	B61178			<b>TEMPO</b>			
Connector From Rad.....	B61177		ⓐA63050	<b>1994-1992</b>			
Inlet (Upper).....			A63049	<b>4-CYL. 2.3 L ENG.</b>			
Inlet Fitting To Trans.....			A63049	Inlet Fitting To Trans.....			A63049
Outlet Fitting To Trans.....				Inlet Hose (Upper).....	≡A63000		
<b>1991-1990</b>				Inlet Tube (Upper).....	≡A63004		
<b>4-CYL. 2.5 L ENG.</b>				Outlet Fitting To Trans.....			A63049
"O" Ring (Connector).....			●A63094	Outlet Tube (Lower).....	≡A63004		
Connector From Rad.....			ⓐA63050	<b>V-6 3.0 L ENG.</b>			
Inlet Fitting To Trans.; W/Factory Inst. Fitting.....			A63049	Inlet Fitting To Trans.....			A63049
Inlet Hose (Upper).....	≡A63000			Inlet Hose (Upper).....	≡A63000		
Inlet Tube (Upper).....	≡A63004			Inlet Tube (Upper).....	≡A63004		
Outlet Fitting To Trans.; W/Factory Inst. Fitting.....			A63049	Outlet Fitting To Trans.....			A63049
Outlet Hose (Lower).....	≡A63000			Outlet Hose (Lower).....	≡A63000		
Outlet Tube (Lower).....	≡A63004			Outlet Tube (Lower).....	≡A63004		
Tube Nut From Rad.; Service Item.			ⓐA63047	<b>1991-1988</b>			
Tube Nut To Trans.; Service Item...			ⓐA63011	<b>4-CYL. 2.3 L ENG.</b>			
<b>V-6 3.0 L ENG.</b>				Inlet Fitting To Trans.....			A63049
"O" Ring (Connector).....			●A63094	Inlet Hose (Upper).....	≡A63000		
Connector From Rad.....			ⓐA63050	Inlet Tube (Upper).....	≡A63004		
Inlet Fitting To Trans.....			A63049	Outlet Fitting To Trans.....			A63049
Outlet Fitting To Trans.....			A63049	Outlet Tube (Lower).....	≡A63004		
<b>V-6 3.8 L ENG.</b>				<b>THUNDERBIRD</b>			
"O" Ring (Connector).....			●A63094	<b>1997-1996</b>			
Aux. Cooler Supply Hose; W/Police Pkg.....		≡A63000		<b>V-6 3.8 L ENG.; V-8 4.6 L ENG.</b>			
Aux. Cooler Supply Tube (Lower); W/Police Pkg.....	B61178			"O" Ring (Connector & Fitting).....			●A63094
Connector From Rad.....	B61177		ⓐA63050	Connector From Rad.....			ⓐA63050
Inlet (Upper).....			A63049	Inlet (Upper).....	≡A63004		
Inlet Fitting To Trans.....			A63049	Outlet (Lower).....	≡A63004		
Outlet Fitting To Trans.....				Tube Nut From Rad.....			ⓐA63047
<b>1989-1988</b>				Tube Nut To Trans.....			ⓐA63011
<b>4-CYL. 2.5 L ENG.; V-6 3.0 L ENG.; V-6 3.8 L ENG.</b>				<b>1995-1994</b>			
"O" Ring (Connector).....			●A63094	<b>V-6 3.8 L ENG.</b>			
Connector From Rad.....			ⓐA63050	"O" Ring (Connector & Fitting).....			●A63094
Inlet Fitting To Trans.; W/Factory Inst. Fitting.....			A63049	Connector From Rad.....			ⓐA63050
Inlet Hose (Upper).....	≡A63000			Inlet (Driver Side); W/Supercharger	≡A63004		
Inlet Tube (Upper).....	≡A63004			Inlet (Upper); W/O Supercharger....	B61234		
Outlet Fitting To Trans.; W/Factory Inst. Fitting.....			A63049	Outlet (Lower); W/O Supercharger..	B61176		
Outlet Hose (Lower); W/ATX Trans.....	≡A63000			Outlet (Pass. Side); W/Supercharger .....		≡A63004	
Outlet Tube (Lower); W/ATX Trans.	≡A63004			Tube Nut From Rad.; W/Supercharger .....			ⓐA63047
Tube Nut From Rad.; Service Item.			ⓐA63047	Tube Nut To Trans.; W/Supercharger .....			ⓐA63011
Tube Nut To Trans.; Service Item...			ⓐA63011	<b>V-8 4.6 L ENG.</b>			
<b>1987-1986</b>				<b>"O" Ring (Connector &amp; Fitting).....</b>			
<b>4-CYL. 2.5 L ENG.; V-6 3.0 L ENG.</b>				<b>Connector From Rad.....</b>			
"O" Ring (Connector).....			●A63094	Inlet Hose (Upper).....	≡A63000		
Connector From Rad.....			ⓐA63050	Inlet Tube (Upper).....	≡A63004		
Inlet Fitting To Trans.; W/Factory Inst. Fitting.....			A63049	Outlet Hose (Lower).....	≡A63000		
Inlet Hose (Upper).....	≡A63000			Outlet Tube (Lower).....	≡A63004		
Inlet Tube (Upper).....	≡A63004			<b>1993-1991</b>			
Outlet Fitting To Trans.; W/Factory Inst. Fitting.....			A63049	<b>V-6 3.8 L ENG.</b>			
Outlet Hose (Lower); W/ATX Trans.....	≡A63000			<b>"O" Ring (Connector &amp; Fitting).....</b>			
Outlet Tube (Lower); W/ATX Trans.	≡A63004			<b>Aux. Cooler Hose; W/3/8" I.D.</b>			
Tube Nut From Rad.; Service Item.			ⓐA63047	<b>Hose.....</b>			
				<b>Aux. Cooler Hose; W/5/16" I.D.</b>			
				<b>Hose.....</b>			
				<b>Connector From Rad.....</b>			

② Two Required.  
③ Three Required.

④ Four Required.  
⑤ Five Required.

⑥ Six Required.  
⑦ Seven Required.

≡ Cut To Fit.  
● As Required.

See Pages 1 - 10 for Engine Oil Cooler Applications.

# Transmission Oil Cooler Assemblies for Passenger Cars & Light Trucks

Application	Assembly Number	Hoses & Tubes	Connectors & Fittings	Application	Assembly Number	Hoses & Tubes	Connectors & Fittings
<b>FORD - Continued</b>				<b>FORD - Continued</b>			
<b>THUNDERBIRD - Continued</b>				<b>WINDSTAR</b>			
<b>1993-1991 - Continued</b>				<b>2003-2001</b>			
<b>V-6 3.8 L ENG. - Continued</b>				<b>V-6 3.8 L ENG.</b>			
Inlet (Driver Side); W/Supercharger		∅-A63004		Inlet Fitting To Trans.....			A63076
Inlet (Upper); W/O Supercharger.....	B61234			Outlet Fitting To Trans.....			A63076
Outlet (Lower); W/O Supercharger..	B61176			<b>2000-1999</b>			
Outlet (Pass. Side);				<b>V-6 3.0 L ENG.; V-6 3.8 L ENG.</b>			
W/Supercharger .....		∅-A63004		Inlet Fitting To Trans.....			A63076
Tube Nut From Rad.;			②A63047	Outlet Fitting To Trans.....			A63076
W/Supercharger .....				<b>1998-1995</b>			
Tube Nut To Trans.;			②A63011	<b>V-6 3.0 L ENG.; V-6 3.8 L ENG.</b>			
W/Supercharger .....				Inlet Fitting To Trans.....			A63049
<b>V-8 5.0 L ENG.</b>				Outlet Fitting To Trans.....			A63049
"O" Ring (Connector & Fitting) .....			●A63094	<b>ZX2</b>			
Aux. Cooler Hose; W/3/8" I.D.		∅-A63001		<b>2003</b>			
Hose .....		∅-A63000		<b>4-CYL. 2.0 L ENG.</b>			
Aux. Cooler Hose; W/5/16" I.D.		∅-A63000		Banjo Washers; W/14mm I.D. Ban-			●A63103
Hose .....		∅-A63000		jo.....			●A63104
Connector From Rad. ....			②A63050	Banjo Washers; W/16mm I.D. Ban-			
Inlet (Upper) .....	B61234			jo.....			
Outlet (Lower).....	B61176			Outlet Hose .....		∅-A63000	
<b>1990</b>				<b>GMC</b>			
<b>V-6 3.8 L ENG.</b>				<b>C &amp; K SERIES PICKUP</b>			
"O" Ring (Connector & Fitting) .....			●A63094	<b>2002-2001</b>			
Aux. Cooler Hose; W/3/8" I.D.		∅-A63001		<b>V-8 6.5 L DIESEL ENG.</b>			
Hose .....		∅-A63000		Aux. Cooler Inlet (Pass. Side).....	A61027		
Aux. Cooler Hose; W/5/16" I.D.		∅-A63000		Aux. Cooler Outlet (Driver Side).....	B61108		
Hose .....		∅-A63000		Connector From Aux. Cooler.....			②A63019
Connector From Rad. ....			②A63050	Inlet Fitting To Trans. (Upper); Ser-			A63007
Inlet (Driver Side); W/Supercharger		∅-A63004		vice Item.....			A63006
Inlet (Upper); W/O Supercharger.....	B61234			Inlet Fitting To Trans. (Upper);			A63027
Outlet (Lower); W/O Supercharger..	B61176			W/Factory Inst. Fitting.....			
Outlet (Pass. Side);				Inlet Fitting To Trans. Case (Up-			
W/Supercharger .....		∅-A63004		per); W/Factory Inst. Fitting.....			
Tube Nut From Rad.;			②A63047	Inlet Tube (Upper); Service Item;			
W/Supercharger .....			②A63011	Remove Current Line & Trans.			
Tube Nut To Trans.;				Fittings. Replace Using Bulk			
W/Supercharger .....				Tubing & Service Item Listed.....		∅-A63005	
<b>1989</b>				Outlet Fitting To Trans. (Lower) .....			A63006
<b>V-6 3.8 L ENG.</b>				Quick Connect Tube Fitting (Low-			A63021
"O" Ring (Connector & Fitting) .....			●A63094	er) .....			A63021
Connector From Rad. ....		∅-A63000	②A63050	Quick Connect Tube Fitting (Up-			A63013
Inlet Hose (Upper).....		∅-A63004		per).....			●A63098
Inlet Tube (Upper).....		∅-A63000		Tube Nut; Service Item.....			●A63099
Outlet Hose (Lower).....		∅-A63000		Wire Retainer (Connectors & Fit-			
Outlet Tube (Lower).....		∅-A63004		tings); W/3/8" Retainer.....			
Tube Nut From Rad.....			②A63047	Wire Retainer (Connectors & Fit-			
Tube Nut To Trans. ....			②A63011	tings); W/5/8" Retainer.....			
<b>1988</b>				<b>V-8 8.1 L ENG.</b>			
<b>4-CYL. 2.3 L ENG.; V-6 3.8 L ENG.; V-8 5.0 L ENG.</b>				Connector From Aux. Cooler.....			
"O" Ring (Connector) .....			●A63094	Inlet Fitting To Trans. (Upper); Ser-			②A63019
"O" Ring (Fitting); Apr. 18 & Newer			●A63094	vice Item.....			A63007
Connector From Rad. ....			②A63050	Inlet Fitting To Trans. (Upper);			A63006
Inlet Fitting To Trans.; Apr. 17 &				W/Factory Inst. Fitting.....			A63027
Older.....			A63049	Inlet Fitting To Trans. Case (Up-			
Inlet Hose .....		∅-A63000		per); W/Factory Inst. Fitting.....			
Inlet Tube .....		∅-A63004		Inlet Tube (Upper); Service Item;			
Outlet Fitting To Trans.; Apr. 17 &				Remove Current Line & Trans.			
Older.....			A63049	Fittings. Replace Using Bulk			
Outlet Hose .....		∅-A63000		Tubing & Service Item Listed.....		∅-A63005	
Outlet Tube.....		∅-A63004		Outlet Fitting To Trans. (Lower) .....			A63006
Tube Nut From Rad.; W/4-Speed				Quick Connect Tube Fitting (Low-			A63021
Auto. Trans.....			②A63047	er) .....			
Tube Nut To Trans. ....			②A63011				

② Two Required.  
③ Three Required.

④ Four Required.  
⑤ Five Required.

⑥ Six Required.  
⑦ Seven Required.

∅ Cut To Fit.  
● As Required.

See Pages 1 - 10 for Engine Oil Cooler Applications.

## Transmission Oil Cooler Assemblies for Passenger Cars &amp; Light Trucks

Application	Assembly Number	Hoses & Tubes	Connectors & Fittings	Application	Assembly Number	Hoses & Tubes	Connectors & Fittings
<b>GMC - Continued</b>				<b>GMC - Continued</b>			
<b>C &amp; K SERIES PICKUP - Continued</b>				<b>C &amp; K SERIES PICKUP - Continued</b>			
<b>2002-2001 - Continued</b>				<b>2000 - Continued</b>			
<b>V-8 8.1 L ENG. - Continued</b>				<b>V-8 6.5 L DIESEL ENG. - Continued</b>			
Quick Connect Tube Fitting (Upper) .....			A63021	Inlet Fitting To Trans. (Upper); Service Item .....			A63007
Tube Nut; Service Item .....			②A63013	Inlet Fitting To Trans. (Upper); W/Factory Inst. Fitting .....			A63006
Wire Retainer (Connectors & Fittings); W/3/8" Retainer .....			●A63098	Inlet Fitting To Trans. Case (Upper) .....			A63027
Wire Retainer (Connectors & Fittings); W/5/8" Retainer .....			●A63099	Inlet Tube (Upper); Service Item; Remove Current Line & Trans. Fittings. Replace Using Bulk Tubing & Service Item Listed .....	≠A63005		A63006
<b>2000</b>				Outlet Fitting To Trans. (Lower) .....			A63021
<b>V-8 5.7 L ENG.</b>				Quick Connect Tube Fitting (Lower) .....			A63021
Aux. Cooler Inlet (Pass. Side); 3500HD .....	A61027			Quick Connect Tube Fitting (Upper) .....			A63021
Aux. Cooler Inlet (Pass. Side); Exc. 3500HD; W/16-Bolt Trans. Pan (M30) .....	B61056			Tube Nut; Service Item .....			②A63013
Aux. Cooler Inlet (Pass. Side); Exc. 3500HD; W/17-Bolt Trans. Pan (MT1) .....	A61028			Wire Retainer (Connectors & Fittings); W/3/8" Retainer .....			●A63098
Aux. Cooler Outlet (Driver Side); 3500HD .....	B61108			Wire Retainer (Connectors & Fittings); W/5/8" Retainer .....			●A63099
Aux. Cooler Outlet (Driver Side); Exc. 3500HD; W/16-Bolt Trans. Pan (M30) .....	B61058			<b>V-8 7.4 L ENG.</b>			
Aux. Cooler Outlet (Driver Side); Exc. 3500HD; W/17-Bolt Trans. Pan (MT1) .....	B61029			Aux. Cooler Inlet (Pass. Side); 3500HD .....	A61027		
Connector From Aux. Cooler Inlet (Upper); W/O Aux. Cooler; W/16-Bolt Trans. Pan (M30) .....	B61057		②A63019	Aux. Cooler Inlet (Pass. Side); Exc. 3500HD .....	B61025		
Inlet Fitting To Trans. (Upper); Service Item .....			A63007	Aux. Cooler Outlet (Driver Side); 3500HD .....	B61108		
Inlet Fitting To Trans. (Upper); W/16-Bolt Trans. Pan (M30) .....			A63007	Aux. Cooler Outlet (Driver Side); Exc. 3500HD .....	B61026		
Inlet Fitting To Trans. (Upper); W/Factory Inst. Fitting; W/17-Bolt Trans. Pan (MT1) .....			A63006	Connector From Aux. Cooler .....			②A63019
Inlet Fitting To Trans. Case (Upper); W/Factory Inst. Fitting; W/17-Bolt Trans. Pan (MT1) .....			A63027	Inlet Fitting To Trans. (Upper); Service Item .....			A63007
Inlet Tube (Upper); W/Aux. Cooler; Service Item; Remove Current Line & Trans. Fittings. Replace Using Bulk Tubing & Service Item Listed .....		≠A63005		Inlet Fitting To Trans. (Upper); W/Factory Inst. Fitting .....			A63006
Outlet (Lower); W/O Aux. Cooler; W/16-Bolt Trans. Pan (M30) .....	B61055			Inlet Fitting To Trans. Case (Upper) .....			A63027
Outlet Fitting To Trans. (Lower); W/16-Bolt Trans. Pan (M30) .....			A63007	Inlet Tube (Upper); Service Item; Remove Current Line & Trans. Fittings. Replace Using Bulk Tubing & Service Item Listed .....		≠A63005	A63006
Outlet Fitting To Trans. (Lower); W/17-Bolt Trans. Pan (MT1) .....			A63006	Outlet Fitting To Trans. (Lower) .....			A63021
Quick Connect Tube Fitting (Lower) .....			A63021	Quick Connect Tube Fitting (Lower) .....			A63021
Quick Connect Tube Fitting (Upper) .....			A63021	Quick Connect Tube Fitting (Upper); W/Factory Inst. Fitting .....			A63021
Tube Nut; Service Item .....			②A63013	Tube Nut; Service Item .....			②A63013
Wire Retainer (Connectors & Fittings); W/3/8" Retainer .....			●A63098	Wire Retainer (Connectors & Fittings); W/3/8" Retainer .....			●A63098
Wire Retainer (Connectors & Fittings); W/5/8" Retainer .....			●A63099	Wire Retainer (Connectors & Fittings); W/5/8" Retainer .....			●A63099
<b>V-8 6.5 L DIESEL ENG.</b>				<b>1999</b>			
Aux. Cooler Inlet (Pass. Side); 3500HD .....	A61027			<b>V-8 5.0 L ENG.</b>			
Aux. Cooler Inlet (Pass. Side); Exc. 3500HD .....	A61028			Inlet (Upper); W/140A. Gen. ....	B61057		
Aux. Cooler Outlet (Driver Side); 3500HD .....	B61108			Inlet (Upper); W/O 140A. Gen. ....	B61059		
Aux. Cooler Outlet (Driver Side); Exc. 3500HD .....	B61107			Inlet Fitting To Trans. (Upper) .....			A63007
Connector From Aux. Cooler .....			②A63019	Outlet (Lower); W/140A. Gen. ....	B61055		
				Outlet (Lower); W/O 140A. Gen. ....	B61060		
				Outlet Fitting To Trans. (Lower) .....			A63007
				Quick Connect Tube Fitting (Lower) .....			A63021
				Quick Connect Tube Fitting (Upper) .....			A63021
				Wire Retainer (Fittings); W/3/8" Retainer .....			●A63098
				Wire Retainer (Fittings); W/5/8" Retainer .....			●A63099
				<b>V-8 5.7 L ENG.</b>			
				Aux. Cooler Inlet (Pass. Side); 3500HD .....	A61027		

② Two Required.  
③ Three Required.

④ Four Required.  
⑤ Five Required.

⑥ Six Required.  
⑦ Seven Required.

≠ Cut To Fit.  
● As Required.

See Pages 1 - 10 for Engine Oil Cooler Applications.



# Transmission Oil Cooler Assemblies for Passenger Cars & Light Trucks

Application	Assembly Number	Hoses & Tubes	Connectors & Fittings	Application	Assembly Number	Hoses & Tubes	Connectors & Fittings
<b>GMC - Continued</b>				<b>GMC - Continued</b>			
<b>C &amp; K SERIES PICKUP - Continued</b>				<b>C &amp; K SERIES PICKUP - Continued</b>			
<b>1999 - Continued</b>				<b>1999 - Continued</b>			
<b>V-8 5.7 L ENG. - Continued</b>				<b>V-8 6.5 L DIESEL ENG. - Continued</b>			
Aux. Cooler Inlet (Pass. Side); Exc. 3500HD; W/16-Bolt Trans. Pan (M30) .....	B61056			Quick Connect Tube Fitting (Upper) .....			A63021
Aux. Cooler Inlet (Pass. Side); Exc. 3500HD; W/17-Bolt Trans. Pan (MT1) .....	A61028			Tube Nut; Service Item .....			ⓐA63013
Aux. Cooler Outlet (Driver Side); 3500HD .....	B61108			Wire Retainer (Connectors & Fittings); W/3/8" Retainer .....			●A63098
Aux. Cooler Outlet (Driver Side); Exc. 3500HD; W/16-Bolt Trans. Pan (M30) .....	B61058			Wire Retainer (Connectors & Fittings); W/5/8" Retainer .....			●A63099
Aux. Cooler Outlet (Driver Side); Exc. 3500HD; W/17-Bolt Trans. Pan (MT1) .....	B61029			<b>V-8 7.4 L ENG.</b>			
Connector From Aux. Cooler Inlet (Upper); W/O Aux. Cooler; W/16-Bolt Trans. Pan (M30) .....	B61057		ⓐA63019	Aux. Cooler Inlet (Pass. Side); 3500HD .....	A61027		
Inlet Fitting To Trans. (Upper); Service Item .....			A63007	Aux. Cooler Inlet (Pass. Side); Exc. 3500HD .....	B61025		
Inlet Fitting To Trans. (Upper); W/16-Bolt Trans. Pan (M30) .....			A63007	Aux. Cooler Outlet (Driver Side); 3500HD .....	B61108		
Inlet Fitting To Trans. (Upper); W/Factory Inst. Fitting; W/17-Bolt Trans. Pan (MT1) .....			A63006	Aux. Cooler Outlet (Driver Side); Exc. 3500HD .....	B61026		
Inlet Fitting To Trans. Case (Upper); W/Factory Inst. Fitting; W/17-Bolt Trans. Pan (MT1) .....			A63027	Connector From Aux. Cooler Inlet Fitting To Trans. (Upper); Service Item .....			ⓐA63019
Inlet Tube (Upper); W/Aux. Cooler; Service Item; Remove Current Line & Trans. Fittings. Replace Using Bulk Tubing & Service Item Listed .....		≠A63005		Inlet Fitting To Trans. (Upper); W/Factory Inst. Fitting .....			A63007
Outlet (Lower); W/O Aux. Cooler; W/16-Bolt Trans. Pan (M30) .....	B61055			Inlet Fitting To Trans. Case (Upper) .....			A63006
Outlet Fitting To Trans. (Lower); W/16-Bolt Trans. Pan (M30) .....			A63007	Inlet Tube (Upper); Service Item; Remove Current Line & Trans. Fittings. Replace Using Bulk Tubing & Service Item Listed .....		≠A63005	A63027
Outlet Fitting To Trans. (Lower); W/17-Bolt Trans. Pan (MT1) .....			A63006	Outlet Fitting To Trans. (Lower) .....			A63006
Quick Connect Tube Fitting (Lower) .....			A63021	Quick Connect Tube Fitting (Lower) .....			A63021
Quick Connect Tube Fitting (Upper) .....			A63021	Quick Connect Tube Fitting (Upper); W/Factory Inst. Fitting .....			A63021
Tube Nut; Service Item .....			ⓐA63013	Tube Nut; Service Item .....			ⓐA63013
Wire Retainer (Connectors & Fittings); W/3/8" Retainer .....			●A63098	Wire Retainer (Connectors & Fittings); W/3/8" Retainer .....			●A63098
Wire Retainer (Connectors & Fittings); W/5/8" Retainer .....			●A63099	Wire Retainer (Connectors & Fittings); W/5/8" Retainer .....			●A63099
<b>V-8 6.5 L DIESEL ENG.</b>				<b>1998</b>			
Aux. Cooler Inlet (Pass. Side); 3500HD .....	A61027			<b>V-6 4.3 L ENG.</b>			
Aux. Cooler Inlet (Pass. Side); Exc. 3500HD .....	A61028			Inlet (Upper) .....	B61059		A63007
Aux. Cooler Outlet (Driver Side); 3500HD .....	B61108			Inlet Fitting To Trans. (Upper) .....			A63007
Aux. Cooler Outlet (Driver Side); Exc. 3500HD .....	B61107			Outlet (Lower) .....	B61060		A63007
Connector From Aux. Cooler Inlet Fitting To Trans. (Upper); Service Item .....			ⓐA63019	Outlet Fitting To Trans. (Lower) .....			A63021
Inlet Fitting To Trans. (Upper); W/Factory Inst. Fitting .....			A63007	Quick Connect Tube Fitting (Lower) .....			A63021
Inlet Fitting To Trans. Case (Upper) .....			A63006	Quick Connect Tube Fitting (Upper) .....			A63021
Inlet Tube (Upper); Service Item; Remove Current Line & Trans. Fittings. Replace Using Bulk Tubing & Service Item Listed .....		≠A63005	A63027	Wire Retainer (Fittings); W/3/8" Retainer .....			●A63098
Outlet Fitting To Trans. (Lower) .....			A63006	Wire Retainer (Fittings); W/5/8" Retainer .....			●A63099
Quick Connect Tube Fitting (Lower) .....			A63021	<b>V-8 5.0 L ENG.</b>			
				Inlet (Upper); W/140A. Gen. ....	B61057		
				Inlet (Upper); W/O 140A. Gen. ....	B61059		
				Inlet Fitting To Trans. (Upper) .....			A63007
				Outlet (Lower); W/140A. Gen. ....	B61055		
				Outlet (Lower); W/O 140A. Gen. ....	B61060		
				Outlet Fitting To Trans. (Lower) .....			A63007
				Quick Connect Tube Fitting (Lower) .....			A63021
				Quick Connect Tube Fitting (Upper) .....			A63021
				Wire Retainer (Fittings); W/3/8" Retainer .....			●A63098
				Wire Retainer (Fittings); W/5/8" Retainer .....			●A63099

ⓐ Two Required.  
ⓑ Three Required.

Ⓓ Four Required.  
Ⓔ Five Required.

Ⓢ Six Required.  
Ⓣ Seven Required.

≠ Cut To Fit.  
● As Required.

See Pages 1 - 10 for Engine Oil Cooler Applications.

Product Section

Troubleshooting

EOC Applications

TOC Applications

Numerical Listing

Manufacturers' Part Numbers

End Fittings

Illustrations

## Transmission Oil Cooler Assemblies for Passenger Cars &amp; Light Trucks

Application	Assembly Number	Hoses & Tubes	Connectors & Fittings	Application	Assembly Number	Hoses & Tubes	Connectors & Fittings
<b>GMC - Continued</b>				<b>GMC - Continued</b>			
<b>C &amp; K SERIES PICKUP - Continued</b>				<b>C &amp; K SERIES PICKUP - Continued</b>			
<b>1998 - Continued</b>				<b>1998 - Continued</b>			
<b>V-8 5.7 L ENG.</b>				<b>V-8 6.5 L DIESEL ENG. - Continued</b>			
Aux. Cooler Inlet (Pass. Side); 3500HD .....	A61027			Quick Connect Tube Fitting (Lower) .....			A63021
Aux. Cooler Inlet (Pass. Side); Exc. 3500HD; W/16-Bolt Trans. Pan (M30) .....	B61056			Quick Connect Tube Fitting (Upper) .....			A63021
Aux. Cooler Inlet (Pass. Side); Exc. 3500HD; W/17-Bolt Trans. Pan (MT1) .....	A61028			Tube Nut; Service Item .....			ⓐA63013
Aux. Cooler Outlet (Driver Side); 3500HD .....	B61108			Wire Retainer (Connectors & Fittings); W/3/8" Retainer .....			●A63098
Aux. Cooler Outlet (Driver Side); Exc. 3500HD; W/16-Bolt Trans. Pan (M30) .....	B61058			Wire Retainer (Connectors & Fittings); W/5/8" Retainer .....			●A63099
Aux. Cooler Outlet (Driver Side); Exc. 3500HD; W/17-Bolt Trans. Pan (MT1) .....	B61029			<b>V-8 7.4 L ENG.</b>			
Connector From Aux. Cooler .....			ⓐA63019	Aux. Cooler Inlet (Pass. Side); 3500HD .....	A61027		
Inlet (Upper); W/O Aux. Cooler; W/16-Bolt Trans. Pan (M30) .....	B61057			Aux. Cooler Inlet (Pass. Side); Exc. 3500HD .....	B61025		
Inlet Fitting To Trans. (Upper); Service Item .....			A63007	Aux. Cooler Outlet (Driver Side); 3500HD .....	B61108		
Inlet Fitting To Trans. (Upper); W/16-Bolt Trans. Pan (M30) .....			A63007	Aux. Cooler Outlet (Driver Side); Exc. 3500HD .....	B61026		
Inlet Fitting To Trans. (Upper); W/Factory Inst. Fitting; W/17-Bolt Trans. Pan (MT1) .....			A63006	Connector From Aux. Cooler .....			ⓐA63019
Inlet Fitting To Trans. Case (Upper); W/Factory Inst. Fitting; W/17-Bolt Trans. Pan (MT1) .....			A63027	Inlet Fitting To Trans. (Upper); Service Item .....			A63007
Inlet Tube (Upper); W/Aux. Cooler; Service Item; Remove Current Line & Trans. Fittings. Replace Using Bulk Tubing & Service Item Listed .....			⊖A63005	Inlet Fitting To Trans. (Upper); W/Factory Inst. Fitting .....			A63006
Outlet (Lower); W/O Aux. Cooler; W/16-Bolt Trans. Pan (M30) .....	B61055			Inlet Fitting To Trans. Case (Upper) .....			A63027
Outlet Fitting To Trans. (Lower); W/16-Bolt Trans. Pan (M30) .....			A63007	Inlet Tube (Upper); Service Item; Remove Current Line & Trans. Fittings. Replace Using Bulk Tubing & Service Item Listed .....			⊖A63005
Outlet Fitting To Trans. (Lower); W/17-Bolt Trans. Pan (MT1) .....			A63006	Outlet Fitting To Trans. (Lower) .....			A63006
Quick Connect Tube Fitting (Lower) .....			A63021	Quick Connect Tube Fitting (Lower) .....			A63021
Quick Connect Tube Fitting (Upper) .....			A63021	Quick Connect Tube Fitting (Upper); W/Factory Inst. Fitting .....			A63021
Tube Nut; Service Item .....			ⓐA63013	Tube Nut; Service Item .....			ⓐA63013
Wire Retainer (Connectors & Fittings); W/3/8" Retainer .....			●A63098	Wire Retainer (Connectors & Fittings); W/3/8" Retainer .....			●A63098
Wire Retainer (Connectors & Fittings); W/5/8" Retainer .....			●A63099	Wire Retainer (Connectors & Fittings); W/5/8" Retainer .....			●A63099
<b>V-8 6.5 L DIESEL ENG.</b>				<b>1997</b>			
Aux. Cooler Inlet (Pass. Side); 3500HD .....	A61027			<b>V-6 4.3 L ENG.</b>			
Aux. Cooler Inlet (Pass. Side); Exc. 3500HD .....	A61028			Inlet Fitting To Trans. (Upper) .....			A63007
Aux. Cooler Outlet (Driver Side); 3500HD .....	B61108			Inlet Tube (Upper); Service Item; Remove Current Line & Trans. Fittings. Replace Using Bulk Tubing & Service Item Listed .....			⊖A63005
Aux. Cooler Outlet (Driver Side); Exc. 3500HD .....	B61107			Outlet Fitting To Trans. (Lower) .....			A63007
Connector From Aux. Cooler .....			ⓐA63019	Outlet Tube (Lower); Service Item; Remove Current Line & Trans. Fittings. Replace Using Bulk Tubing & Service Item Listed .....			⊖A63005
Inlet Fitting To Trans. (Upper); Service Item .....			A63007	Quick Connect Tube Fitting (Lower) .....			A63021
Inlet Fitting To Trans. (Upper); W/Factory Inst. Fitting .....			A63006	Quick Connect Tube Fitting (Upper) .....			A63021
Inlet Fitting To Trans. Case (Upper) .....			A63027	Tube Nut; Service Item .....			ⓐA63013
Inlet Tube (Upper); Service Item; Remove Current Line & Trans. Fittings. Replace Using Bulk Tubing & Service Item Listed .....			⊖A63005	Wire Retainer (Fittings); W/3/8" Retainer .....			●A63098
Outlet Fitting To Trans. (Lower) .....			A63006	Wire Retainer (Fittings); W/5/8" Retainer .....			●A63099
				<b>V-8 5.0 L ENG.</b>			
				Inlet Fitting To Trans. (Upper); Service Item .....			A63007
				Inlet Fitting To Trans. (Upper); W/Factory Inst. Fitting .....			A63006
				Inlet Tube (Upper); Service Item; Remove Current Line & Trans. Fittings. Replace Using Bulk Tubing & Service Item Listed .....			⊖A63005

ⓐ Two Required.  
ⓑ Three Required.

Ⓒ Four Required.  
Ⓓ Five Required.

Ⓔ Six Required.  
Ⓕ Seven Required.

⊖ Cut To Fit.  
● As Required.

See Pages 1 - 10 for Engine Oil Cooler Applications.

# Transmission Oil Cooler Assemblies for Passenger Cars & Light Trucks

Application	Assembly Number	Hoses & Tubes	Connectors & Fittings	Application	Assembly Number	Hoses & Tubes	Connectors & Fittings
<b>GMC - Continued</b>				<b>GMC - Continued</b>			
<b>C &amp; K SERIES PICKUP - Continued</b>				<b>C &amp; K SERIES PICKUP - Continued</b>			
<b>1997 - Continued</b>				<b>1997 - Continued</b>			
<b>V-8 5.0 L ENG. - Continued</b>				<b>V-8 6.5 L DIESEL ENG. - Continued</b>			
Outlet Fitting To Trans. (Lower); Service Item .....			A63007	Aux. Cooler Outlet (Driver Side); Exc. 3500HD .....	B61107		
Outlet Fitting To Trans. (Lower); W/Factory Inst. Fitting.....			A63006	Connector From Aux. Cooler.....			②A63019
Outlet Tube (Lower); Service Item; Remove Current Line & Trans. Fittings. Replace Using Bulk Tubing & Service Item Listed.....		⊗A63005		Inlet Fitting To Trans. (Upper); Ser- vice Item.....			A63007
Quick Connect Tube Fitting (Low- er) .....			A63021	Inlet Fitting To Trans. (Upper); W/Factory Inst. Fitting.....			A63006
Quick Connect Tube Fitting (Up- per) .....			A63021	Inlet Fitting To Trans. Case (Up- per) .....			A63027
Tube Nut; Service Item.....			④A63013	Inlet Tube (Upper); Service Item; Remove Current Line & Trans. Fittings. Replace Using Bulk Tubing & Service Item Listed.....		⊗A63005	
Wire Retainer (Fittings); W/3/8" Re- tainer.....			●A63098	Outlet Fitting To Trans. (Lower) .....			A63006
Wire Retainer (Fittings); W/5/8" Re- tainer.....			●A63099	Quick Connect Tube Fitting (Low- er) .....			A63021
<b>V-8 5.7 L ENG.</b>				<b>V-8 7.4 L ENG.</b>			
Aux. Cooler Inlet (Pass. Side); 3500HD .....	A61027			Aux. Cooler Inlet (Pass. Side); 3500HD .....	A61027		
Aux. Cooler Inlet (Pass. Side); Exc. 3500HD; W/16-Bolt Trans. Pan (M30) .....	B61240			Aux. Cooler Inlet (Pass. Side); Exc. 3500HD .....	B61025		
Aux. Cooler Inlet (Pass. Side); Exc. 3500HD; W/17-Bolt Trans. Pan (MT1) .....	A61028			Aux. Cooler Outlet (Driver Side); 3500HD .....	B61108		
Aux. Cooler Outlet (Driver Side); Exc. 3500HD; W/16-Bolt Trans. Pan (M30) .....	B61252			Aux. Cooler Outlet (Driver Side); Exc. 3500HD .....	B61026		
Aux. Cooler Outlet (Driver Side); Exc. 3500HD; W/17-Bolt Trans. Pan (MT1) .....	B61029			Connector From Aux. Cooler.....			②A63019
Connector From Aux. Cooler.....			②A63019	Inlet Fitting To Trans. (Upper); Ser- vice Item.....			A63007
Inlet Fitting To Trans. (Upper); Ser- vice Item.....			A63007	Inlet Fitting To Trans. (Upper); W/Factory Inst. Fitting.....			A63006
Inlet Fitting To Trans. (Upper); W/16-Bolt Trans. Pan (M30).....			A63007	Inlet Fitting To Trans. Case (Up- per) .....			A63027
Inlet Fitting To Trans. (Upper); W/Factory Inst. Fitting; W/17-Bolt Trans. Pan (MT1).....			A63006	Inlet Tube (Upper); Service Item; Remove Current Line & Trans. Fittings. Replace Using Bulk Tubing & Service Item Listed.....		⊗A63005	
Inlet Fitting To Trans. Case (Up- per); W/Factory Inst. Fitting; W/17-Bolt Trans. Pan (MT1) .....			A63027	Outlet Fitting To Trans. (Lower) .....			A63006
Inlet Tube (Upper); Service Item; Remove Current Line & Trans. Fittings. Replace Using Bulk Tubing & Service Item Listed.....		⊗A63005		Quick Connect Tube Fitting (Low- er) .....			A63021
Outlet Fitting To Trans. (Lower); W/16-Bolt Trans. Pan (M30).....			A63007	Quick Connect Tube Fitting (Up- per); W/Factory Inst. Fitting.....			A63021
Outlet Fitting To Trans. (Lower); W/17-Bolt Trans. Pan (MT1) .....			A63006	Tube Nut; Service Item.....			②A63013
Quick Connect Tube Fitting (Low- er) .....			A63021	Wire Retainer (Connectors & Fit- tings); W/3/8" Retainer.....			●A63098
Quick Connect Tube Fitting (Up- per) .....			A63021	Wire Retainer (Connectors & Fit- tings); W/5/8" Retainer.....			●A63099
Tube Nut; Service Item.....			④A63013	<b>1996</b>			
Wire Retainer (Connectors & Fit- tings); W/3/8" Retainer.....			●A63098	<b>V-6 4.3 L ENG.; V-8 5.0 L ENG.</b>			
Wire Retainer (Connectors & Fit- tings); W/5/8" Retainer.....			●A63099	Inlet Fitting To Trans. (Upper); Ser- vice Item.....			A63007
<b>V-8 6.5 L DIESEL ENG.</b>				<b>V-6 4.3 L ENG.; V-8 5.0 L ENG.</b>			
Aux. Cooler Inlet (Pass. Side); 3500HD .....	A61027			Inlet Tube (Upper); Service Item; Remove Current Line & Trans. Fittings. Replace Using Bulk Tubing & Service Item Listed.....		⊗A63005	
Aux. Cooler Inlet (Pass. Side); Exc. 3500HD .....	A61028			Outlet Fitting To Trans. (Lower); Service Item .....			A63007
Aux. Cooler Outlet (Driver Side); 3500HD .....	B61108			Outlet Tube (Lower); Service Item; Remove Current Line & Trans. Fittings. Replace Using Bulk Tubing & Service Item Listed.....		⊗A63005	
				Quick Connect Tube Fitting; W/Factory Inst. Fitting.....			

② Two Required.  
③ Three Required.

④ Four Required.  
⑤ Five Required.

⑥ Six Required.  
⑦ Seven Required.

⊗ Cut To Fit.  
● As Required.

See Pages 1 - 10 for Engine Oil Cooler Applications.

Product Section

Troubleshooting

EOC Applications

TOC Applications

Numerical Listing

Manufacturers' Part Numbers

End Fittings

Illustrations

## Transmission Oil Cooler Assemblies for Passenger Cars &amp; Light Trucks

Application	Assembly Number	Hoses & Tubes	Connectors & Fittings	Application	Assembly Number	Hoses & Tubes	Connectors & Fittings
<b>GMC - Continued</b>				<b>GMC - Continued</b>			
<b>C &amp; K SERIES PICKUP - Continued</b>				<b>C &amp; K SERIES PICKUP - Continued</b>			
<b>1996 - Continued</b>				<b>1996 - Continued</b>			
<b>V-6 4.3 L ENG.; V-8 5.0 L ENG. - Continued</b>				<b>V-8 6.5 L DIESEL ENG. - Continued</b>			
Tube Nut; Service Item.....			④A63013	Wire Retainer (Connectors & Fittings); W/5/8" Retainer.....			●A63099
Wire Retainer (Fittings).....			●A63098				
<b>V-8 5.7 L ENG.</b>				<b>V-8 7.4 L ENG.</b>			
Aux. Cooler Inlet (Pass. Side); 3500HD .....	A61027			Aux. Cooler Inlet (Pass. Side); 3500HD .....	A61027		
Aux. Cooler Inlet (Pass. Side); Exc. 3500HD; W/16-Bolt Trans. Pan (M30) .....	B61240			Aux. Cooler Inlet (Pass. Side); Exc. 3500HD .....	B61025		
Aux. Cooler Inlet (Pass. Side); Exc. 3500HD; W/17-Bolt Trans. Pan (MT1).....	A61028			Aux. Cooler Outlet (Driver Side); Exc. 3500HD .....	B61254		
Aux. Cooler Outlet (Driver Side); Exc. 3500HD; W/16-Bolt Trans. Pan (M30) .....	B61252			Connector From Aux. Cooler.....			②A63019
Aux. Cooler Outlet (Driver Side); Exc. 3500HD; W/17-Bolt Trans. Pan (MT1).....	B61253			Inlet Fitting To Trans. (Upper); Service Item.....			A63007
Connector From Aux. Cooler.....			②A63019	Inlet Fitting To Trans. (Upper); W/Factory Inst. Fitting.....			A63006
Inlet Fitting To Trans. (Upper); Service Item.....			A63007	Inlet Fitting To Trans. Case (Upper) .....			A63027
Inlet Fitting To Trans. (Upper); W/16-Bolt Trans. Pan (M30).....			A63007	Inlet Tube (Upper); Service Item; Remove Current Line & Trans. Fittings. Replace Using Bulk Tubing & Service Item Listed.....		≠A63005	A63006
Inlet Fitting To Trans. (Upper); W/Factory Inst. Fitting; W/17-Bolt Trans. Pan (MT1).....			A63006	Outlet Fitting To Trans. (Lower) .....			A63007
Inlet Tube (Upper); Service Item; Remove Current Line & Trans. Fittings. Replace Using Bulk Tubing & Service Item Listed.....		≠A63005		Outlet Fitting To Trans. (Upper) .....			A63021
Outlet Fitting To Trans. (Lower); W/16-Bolt Trans. Pan (M30).....			A63007	Quick Connect Tube Fitting (Lower) .....			A63021
Outlet Fitting To Trans. (Lower); W/17-Bolt Trans. Pan (MT1) .....			A63006	Quick Connect Tube Fitting (Upper) .....			A63021
Quick Connect Tube Fitting (Lower) .....			A63021	Tube Nut; Service Item.....			②A63013
Quick Connect Tube Fitting (Upper) .....			A63021	Wire Retainer (Connectors & Fittings); W/3/8" Retainer.....			●A63098
Tube Nut; Service Item.....			②A63013	Wire Retainer (Connectors & Fittings); W/5/8" Retainer.....			●A63099
Wire Retainer (Connectors & Fittings); W/3/8" Retainer.....			●A63098				
Wire Retainer (Connectors & Fittings); W/5/8" Retainer.....			●A63099				
<b>V-8 6.5 L DIESEL ENG.</b>				<b>1995-1994</b>			
Aux. Cooler Inlet (Pass. Side); 3500HD .....	A61027			<b>V-6 4.3 L ENG.; V-8 5.0 L ENG.</b>			
Connector From Aux. Cooler.....			②A63019	Inlet (Upper) .....		≠A63004	
Inlet Fitting To Trans. (Upper); Service Item.....			A63007	Inlet Fitting To Trans. (Upper).....			A63006
Inlet Fitting To Trans. (Upper); W/Factory Inst. Fitting.....			A63006	Outlet (Lower).....		≠A63004	A63006
Inlet Tube (Upper); Service Item; Remove Current Line & Trans. Fittings. Replace Using Bulk Tubing & Service Item Listed.....		≠A63005		Outlet Fitting To Trans. (Lower) .....			A63006
Outlet Fitting To Trans. (Lower); Service Item .....			A63007	Tube Nut.....			④A63011
Outlet Fitting To Trans. (Lower); W/Factory Inst. Fitting.....			A63006				
Outlet Tube (Lower); W/O Aux. Cooler; Service Item; Remove Current Line & Trans. Fittings. Replace Using Bulk Tubing & Service Item Listed.....		≠A63005		<b>V-8 5.7 L ENG.</b>			
Quick Connect Tube Fitting (Lower) .....			A63021	Aux. Cooler Inlet (Pass. Side); Exc. 3500HD; W/16-Bolt Trans. Pan (M30) .....	A61217		
Quick Connect Tube Fitting (Upper) .....			A63021	Aux. Cooler Inlet (Pass. Side); Exc. 3500HD; W/17-Bolt Trans. Pan (MT1) .....	A61172		
Tube Nut; Service Item.....			②A63013	Aux. Cooler Outlet (Driver Side); 3500HD .....	B61109		
Wire Retainer (Connectors & Fittings); W/3/8" Retainer.....			●A63098	Aux. Cooler Outlet (Driver Side); Exc. 3500HD; W/16-Bolt Trans. Pan (M30) .....	B61211		
				Aux. Cooler Outlet (Driver Side); Exc. 3500HD; W/17-Bolt Trans. Pan (MT1).....	B61235		
				Connector "O" Ring.....			●A63091
				Connector From Aux. Cooler.....			②A63017
				Inlet (Upper); W/Aux. Cooler .....		≠A63004	
				Inlet (Upper); W/O Aux. Cooler .....		≠A63004	A63006
				Inlet Fitting To Trans. (Upper).....		≠A63004	A63006
				Outlet (Lower); W/O Aux. Cooler .....			●A63011
				Outlet Fitting To Trans. (Lower) .....			●A63110
				Tube Nut.....			
				Wire Retainer (Connectors).....			
				<b>V-8 6.5 L DIESEL ENG.</b>			
				Aux. Cooler Inlet (Pass. Side); W/16-Bolt Trans. Pan (M30).....	B61218		
				Aux. Cooler Inlet (Pass. Side); W/17-Bolt Trans. Pan (MT1) .....	A61219		

② Two Required.  
③ Three Required.

④ Four Required.  
⑤ Five Required.

⑥ Six Required.  
⑦ Seven Required.

≠ Cut To Fit.  
● As Required.

See Pages 1 - 10 for Engine Oil Cooler Applications.

# Transmission Oil Cooler Assemblies for Passenger Cars & Light Trucks

Application	Assembly Number	Hoses & Tubes	Connectors & Fittings	Application	Assembly Number	Hoses & Tubes	Connectors & Fittings
<b>GMC - Continued</b>				<b>GMC - Continued</b>			
<b>C &amp; K SERIES PICKUP - Continued</b>				<b>C &amp; K SERIES PICKUP - Continued</b>			
<b>1995-1994 - Continued</b>				<b>1993 - Continued</b>			
<b>V-8 6.5 L DIESEL ENG. - Continued</b>				<b>V-8 6.5 L DIESEL ENG. - Continued</b>			
Aux. Cooler Outlet (Driver Side); 3500HD .....	B61109			Aux. Cooler Outlet (Driver Side); 3500HD .....	B61109		
Aux. Cooler Outlet (Driver Side); W/16-Bolt Trans. Pan (M30).....	B61212			Aux. Cooler Outlet (Driver Side); W/16-Bolt Trans. Pan (M30).....	B61212		
Aux. Cooler Outlet (Driver Side); W/17-Bolt Trans. Pan (MT1) .....	B61165			Aux. Cooler Outlet (Driver Side); W/17-Bolt Trans. Pan (MT1) .....	B61165		
Connector "O" Ring.....			●A63091	Connector "O" Ring.....			●A63091
Connector From Aux. Cooler.....			②A63017	Connector From Aux. Cooler.....			②A63017
Inlet (Upper) .....	∅A63004		A63006	Inlet (Upper) .....	∅A63004		A63006
Inlet Fitting To Trans. (Upper).....			A63006	Inlet Fitting To Trans. (Upper).....			A63006
Outlet Fitting To Trans. (Lower) .....			●A63011	Outlet Fitting To Trans. (Lower) .....			●A63011
Tube Nut.....			●A63110	Tube Nut.....			●A63110
Wire Retainer (Connectors) .....				Wire Retainer (Connectors) .....			
<b>V-8 7.4 L ENG.</b>				<b>V-8 7.4 L ENG.</b>			
Aux. Cooler Inlet (Pass. Side); Exc. 3500HD .....	B61169			Aux. Cooler Inlet (Pass. Side); Exc. 3500HD .....	B61169		
Aux. Cooler Outlet (Driver Side); 3500HD .....	B61109			Aux. Cooler Outlet (Driver Side); 3500HD .....	B61109		
Aux. Cooler Outlet (Pass. Side); Exc. 3500HD .....	B61159			Aux. Cooler Outlet (Pass. Side); Exc. 3500HD .....	B61159		
Connector "O" Ring.....			●A63091	Connector "O" Ring.....			●A63091
Connector From Aux. Cooler.....			②A63017	Connector From Aux. Cooler.....			②A63017
Inlet (Upper) .....	∅A63004		A63006	Inlet (Upper) .....	∅A63004		A63006
Inlet Fitting To Trans. (Upper).....			A63006	Inlet Fitting To Trans. (Upper).....			A63006
Outlet Fitting To Trans. (Lower) .....			●A63011	Outlet Fitting To Trans. (Lower) .....			●A63011
Tube Nut.....			●A63110	Tube Nut.....			●A63110
Wire Retainer (Connectors) .....				Wire Retainer (Connectors) .....			
<b>1993</b>				<b>1992</b>			
<b>V-6 4.3 L ENG.; V-8 5.0 L ENG.</b>				<b>V-6 4.3 L ENG.; V-8 5.0 L ENG.; V-8 5.7 L ENG.; V-8 6.2 L DIESEL ENG.; V-8 6.5 L DIESEL ENG.; V-8 7.4 L ENG.</b>			
Inlet (Lower) .....	∅A63004		A63006	Inlet (Upper) .....	∅A63004		A63006
Inlet Fitting To Trans. (Lower).....				Inlet Fitting To Trans. (Upper).....			A63006
Outlet (Upper).....	∅A63004		A63006	Outlet (Lower).....	∅A63004		A63006
Outlet Fitting To Trans. (Upper).....			④A63011	Outlet Fitting To Trans. (Lower) .....			A63006
Tube Nut.....				Tube Nut.....			④A63011
<b>V-8 5.7 L ENG.</b>				<b>1991-1988</b>			
Aux. Cooler Inlet (Pass. Side); Exc. 3500HD; W/16-Bolt Trans. Pan (M30) .....	A61217			<b>V-6 4.3 L ENG.; V-8 5.0 L ENG.; V-8 5.7 L ENG.; V-8 6.2 L DIESEL ENG.; V-8 7.4 L ENG.</b>			
Aux. Cooler Inlet (Pass. Side); Exc. 3500HD; W/17-Bolt Trans. Pan (MT1).....	A61172			Inlet (Upper) .....	∅A63004		A63006
Aux. Cooler Outlet (Driver Side); Exc. 3500HD; W/16-Bolt Trans. Pan (M30).....	B61211			Inlet Fitting To Trans. (Upper).....			A63006
Aux. Cooler Outlet (Driver Side); Exc. 3500HD; W/17-Bolt Trans. Pan (MT1).....	B61235			Outlet (Lower).....	∅A63004		A63006
Connector "O" Ring.....			●A63091	Outlet Fitting To Trans. (Lower) .....			④A63011
Connector From Aux. Cooler.....			②A63017	Tube Nut.....			
Inlet (Upper); W/Aux. Cooler .....	∅A63004		A63006	<b>1986-1985</b>			
Inlet (Upper); W/O Aux. Cooler .....	∅A63004		●A63011	<b>6-CYL. 4.8 L ENG.; V-6 4.3 L ENG.; V-8 5.0 L ENG.; V-8 5.7 L ENG.; V-8 6.2 L DIESEL ENG.; V-8 7.4 L ENG.</b>			
Inlet Fitting To Trans. (Upper).....			●A63110	Inlet (Upper) .....	∅A63004		A63006
Outlet (Lower); W/O Aux. Cooler .....	∅A63004			Inlet Fitting To Trans. (Upper).....			A63006
Outlet Fitting To Trans. (Lower) .....				Outlet (Lower).....	∅A63004		A63006
Tube Nut.....				Outlet Fitting To Trans. (Lower) .....			A63006
Wire Retainer (Connectors) .....				Tube Nut.....			④A63011
<b>V-8 6.2 L DIESEL ENG.</b>				<b>CABALLERO</b>			
Inlet (Upper) .....	∅A63004		A63006	<b>1987-1986</b>			
Inlet Fitting To Trans. (Upper).....				<b>V-6 4.3 L ENG.; V-8 5.0 L ENG.</b>			
Outlet (Lower).....	∅A63004		A63006	Inlet (Lower) .....	∅A63004		A63006
Outlet Fitting To Trans. (Lower) .....			④A63011	Inlet Fitting To Trans. (Lower).....			A63006
Tube Nut.....				Outlet (Upper).....	∅A63004		A63006
<b>V-8 6.5 L DIESEL ENG.</b>				<b>V-6 4.3 L ENG.; V-8 5.0 L ENG.</b>			
Aux. Cooler Inlet (Pass. Side); W/16-Bolt Trans. Pan (M30).....	B61218			Inlet (Lower) .....	∅A63004		A63006
Aux. Cooler Inlet (Pass. Side); W/17-Bolt Trans. Pan (MT1) .....	A61219			Inlet Fitting To Trans. (Lower).....			A63006

② Two Required.  
③ Three Required.

④ Four Required.  
⑤ Five Required.

⑥ Six Required.  
⑦ Seven Required.

∅ Cut To Fit.  
● As Required.

See Pages 1 - 10 for Engine Oil Cooler Applications.

## Transmission Oil Cooler Assemblies for Passenger Cars &amp; Light Trucks

Application	Assembly Number	Hoses & Tubes	Connectors & Fittings	Application	Assembly Number	Hoses & Tubes	Connectors & Fittings
<b>GMC - Continued</b>				<b>GMC - Continued</b>			
<b>ENVOY</b>				<b>G SERIES VAN - Continued</b>			
<b>2004-2003</b>				<b>1995-1994 - Continued</b>			
<b>6-CYL. 4.2 L ENG.</b>				<b>V-8 7.4 L ENG. - Continued</b>			
Inlet Fitting To Trans. (Lower).....			A63021	Outlet (Lower); W/Aux. Cooler.....	B61214		
Outlet Fitting To Trans. (Upper).....			A63021	Outlet (Lower); W/O Aux. Cooler....		≠A63004	A63006
Wire Retainer (Connectors & Fittings).....			●A63098	Outlet Fitting To Trans. (Lower).....			●A63011
<b>V-8 5.3 L ENG.</b>				<b>1993-1988</b>			
Aux. Cooler Inlet (Pass. Side).....	B61264			<b>V-6 4.3 L ENG.; V-8 5.0 L ENG.; V-8 5.7 L ENG.; V-8 6.2 L DIESEL ENG.; V-8 7.4 L ENG.</b>			
Aux. Cooler Outlet (Driver Side).....	B61266			Inlet (Upper).....		≠A63004	
Connector From Rad.; W/Aux. Cooler.....			●A63019	Inlet Fitting To Trans. (Upper).....			A63006
Connector From Rad.; W/O Aux. Cooler.....			●A63018	Outlet (Lower).....		≠A63004	A63006
Inlet (Upper); W/O Aux. Cooler.....	B61267		A63021	Outlet Fitting To Trans. (Lower).....			●A63011
Inlet Fitting To Trans. (Upper).....			A63021	<b>1987-1986</b>			
Outlet (Lower).....	B61262		A63006	<b>V-6 4.3 L ENG.; V-8 5.0 L ENG.; V-8 5.7 L ENG.; V-8 6.2 L DIESEL ENG.</b>			
Outlet Fitting To Trans. (Lower).....			●A63098	Inlet (Upper).....		≠A63004	
Wire Retainer (Connectors & Fittings).....				Inlet Fitting To Trans. (Upper).....			A63006
<b>2002</b>				Outlet (Lower).....		≠A63004	A63006
<b>6-CYL. 4.2 L ENG.</b>				Outlet Fitting To Trans. (Lower).....			●A63011
Inlet Fitting To Trans. (Lower).....			A63021	<b>2001-1996</b>			
Outlet Fitting To Trans. (Upper).....			A63021	<b>V-6 4.3 L ENG. (CANADA)</b>			
Wire Retainer (Connectors & Fittings).....			●A63098	Connector From Rad. ....			⊕A63018
<b>G SERIES VAN</b>				<b>2004-2002</b>			
<b>1996</b>				<b>V-6 4.3 L ENG. (CANADA)</b>			
<b>V-6 4.3 L ENG.; V-8 5.7 L ENG.; V-8 6.5 L DIESEL ENG.</b>				Connector From Rad. ....			⊕A63018
Aux. Cooler Inlet Hose (Lower).....	A61220			Inlet (Lower).....	B61042		A63021
Inlet (Upper).....			≠A63004	Inlet Fitting To Trans. (Lower).....			A63021
Inlet Fitting To Trans. (Upper).....			A63006	Outlet (Upper).....	B61043		A63021
Outlet (Lower); W/O Aux. Cooler....			≠A63004	Outlet Fitting To Trans. (Upper).....			●A63098
Outlet Fitting To Trans. (Lower).....			A63006	Wire Retainer (Connectors & Fittings).....			
Tube Nut.....			●A63011	<b>2001-1996</b>			
<b>V-8 7.4 L ENG.</b>				<b>V-6 4.3 L ENG.</b>			
Aux. Cooler Inlet Hose (Lower).....	A61213			Connector From Rad. ....			⊕A63018
Inlet (Upper).....			≠A63004	Inlet (Lower).....	B61042		A63021
Inlet Fitting To Trans. (Upper).....			A63006	Inlet Fitting To Trans. (Lower).....			A63021
Outlet (Lower); W/Aux. Cooler.....	B61214			Outlet (Upper).....	B61043		A63021
Outlet (Lower); W/O Aux. Cooler....			≠A63004	Outlet Fitting To Trans. (Upper).....			●A63098
Outlet Fitting To Trans. (Lower).....			A63006	Wire Retainer (Connectors & Fittings).....			
Tube Nut.....			●A63011	<b>1995-1992</b>			
<b>1995-1994</b>				<b>V-6 4.3 L ENG.</b>			
<b>V-6 4.3 L ENG.; V-8 5.0 L ENG.; V-8 5.7 L ENG.; V-8 6.5 L DIESEL ENG.</b>				Connector From Rad. ....			⊕A63006
Aux. Cooler Inlet Hose From Rad. (Lower); W/16-Bolt Trans. Pan (M30).....	B61215			Inlet Fitting To Trans. (Lower).....			A63006
Aux. Cooler Inlet Hose From Rad. (Lower); W/17-Bolt Trans. Pan (MT1).....	A61220			Inlet Tube (Lower).....		≠A63004	A63006
Inlet (Upper).....			≠A63004	Outlet Fitting To Trans. (Upper).....			≠A63004
Inlet Fitting To Trans. (Upper).....			A63006	Outlet Tube (Upper).....			⊕A63011
Outlet (Lower); W/Aux. Cooler; W/16-Bolt Trans. Pan (M30).....	B61216			<b>1991-1990</b>			
Outlet (Lower); W/Aux. Cooler; W/17-Bolt Trans. Pan (MT1).....			≠A63004	<b>V-6 4.3 L ENG.; V-8 5.7 L ENG.</b>			
Outlet (Lower); W/O Aux. Cooler....			≠A63004	Inlet Fitting To Trans. ....			A63006
Outlet Fitting To Trans. (Lower).....			A63006	Inlet Tube.....		≠A63004	A63006
Tube Nut.....			●A63011	Outlet Fitting To Trans. ....			A63006
<b>V-8 7.4 L ENG.</b>				Outlet Tube.....		≠A63004	⊕A63011
Aux. Cooler Inlet Hose From Rad. (Lower).....	A61213			Tube Nut.....			⊕A63011
Inlet (Upper).....			≠A63004	<b>V-8 6.2 L DIESEL ENG.</b>			
Inlet Fitting To Trans. (Upper).....			A63006	Connector From Aux. Cooler.....			⊕A63017
Outlet (Lower); W/Aux. Cooler; W/17-Bolt Trans. Pan (MT1).....			≠A63004	Inlet Fitting To Trans. (Upper).....			A63006
Outlet (Lower); W/O Aux. Cooler....			≠A63004	Inlet Tube.....		≠A63004	A63006
Outlet Fitting To Trans. (Lower).....			A63006	Outlet Fitting To Trans. (Lower).....			A63006
Tube Nut.....			●A63011	Outlet Tube.....		≠A63004	

⊕ Two Required.  
⊖ Three Required.

Ⓞ Four Required.  
Ⓟ Five Required.

Ⓠ Six Required.  
Ⓡ Seven Required.

≠ Cut To Fit.  
● As Required.

See Pages 1 - 10 for Engine Oil Cooler Applications.

## Transmission Oil Cooler Assemblies for Passenger Cars & Light Trucks

Application	Assembly Number	Hoses & Tubes	Connectors & Fittings	Application	Assembly Number	Hoses & Tubes	Connectors & Fittings
<b>GMC - Continued</b>				<b>GMC - Continued</b>			
<b>JIMMY - Continued</b>				<b>R &amp; V SERIES PICKUP - Continued</b>			
<b>1991-1990 - Continued</b>				<b>1988</b>			
<b>V-8 6.2 L DIESEL ENG. - Continued</b>				<b>6-CYL. 4.8 L ENG.; V-8 5.7 L ENG.; V-8 6.2 L DIESEL ENG.; V-8 7.4 L ENG.</b>			
Tube Nut.....			●A63011	Inlet (Upper).....		∅A63004	A63006
Wire Retainer (Connectors).....			●A63110	Inlet Fitting To Trans. (Upper).....		∅A63004	A63006
<b>1989</b>				<b>1987</b>			
<b>V-6 2.8 L ENG.; V-6 4.3 L ENG.; V-8 5.7 L ENG.</b>				<b>6-CYL. 4.8 L ENG.; V-6 4.3 L ENG.; V-8 5.0 L ENG.; V-8 5.7 L ENG.; V-8 6.2 L DIESEL ENG.; V-8 7.4 L ENG.</b>			
Inlet Fitting To Trans.....			A63006	Inlet (Upper).....		∅A63004	A63006
Inlet Tube.....		∅A63004		Inlet Fitting To Trans. (Upper).....		∅A63004	A63006
Outlet Fitting To Trans.....			A63006	Outlet (Lower).....		∅A63004	A63006
Outlet Tube.....		∅A63004		Outlet Fitting To Trans. (Lower).....			A63006
Tube Nut.....			④A63011	Tube Nut.....			④A63011
<b>V-8 6.2 L DIESEL ENG.</b>				<b>S SERIES PICKUP</b>			
Connector From Aux. Cooler.....			②A63017	<b>1990-1988</b>			
Inlet Fitting To Trans. (Upper).....			A63006	<b>4-CYL. 2.5 L ENG.; V-6 2.8 L ENG.; V-6 4.3 L ENG.</b>			
Inlet Tube.....		∅A63004		Inlet (Lower).....		∅A63004	A63006
Outlet Fitting To Trans. (Lower).....			A63006	Inlet Fitting To Trans. (Lower).....		∅A63004	A63006
Outlet Tube.....		∅A63004		Outlet (Upper).....		∅A63004	A63006
Tube Nut.....			●A63011	Outlet Fitting To Trans. (Upper).....			④A63011
Wire Retainer (Connectors).....			●A63110	Tube Nut.....			
<b>1988</b>				<b>1987-1986</b>			
<b>4-CYL. 2.5 L ENG.; V-6 2.8 L ENG.; V-6 4.3 L ENG.; V-8 5.7 L ENG.</b>				<b>4-CYL. 2.5 L ENG.; V-6 2.8 L ENG.</b>			
Inlet Fitting To Trans.....			A63006	Inlet (Lower).....		∅A63004	A63006
Inlet Tube.....		∅A63004		Inlet Fitting To Trans. (Lower).....		∅A63004	A63006
Outlet Fitting To Trans.....			A63006	Outlet (Upper).....		∅A63004	A63006
Outlet Tube.....		∅A63004		Outlet Fitting To Trans. (Upper).....			④A63011
Tube Nut.....			④A63011	Tube Nut.....			
<b>V-8 6.2 L DIESEL ENG.</b>				<b>2005-1996</b>			
Connector From Aux. Cooler.....			②A63017	<b>V-6 4.3 L ENG.</b>			
Inlet Fitting To Trans. (Upper).....			A63006	Connector From Rad. ....			
Inlet Tube.....		∅A63004		Inlet (Upper).....			
Outlet Fitting To Trans. (Lower).....			A63006	Inlet Fitting To Trans. (Upper).....			
Outlet Tube.....		∅A63004		Outlet (Lower).....			
Tube Nut.....			●A63011	Outlet Fitting To Trans. (Lower).....			
Wire Retainer (Connectors).....			●A63110	Wire Retainer (Connectors & Fittings).....			
<b>1987</b>				<b>1995</b>			
<b>4-CYL. 2.5 L ENG.; V-6 2.8 L ENG.; V-8 5.0 L ENG.; V-8 5.7 L ENG.</b>				<b>V-6 4.3 L ENG.</b>			
Inlet Fitting To Trans.....			A63006	Inlet Fitting To Trans. (Upper).....			
Inlet Tube.....		∅A63004		Outlet Fitting To Trans. (Lower).....			
Outlet Fitting To Trans.....			A63006	Inlet Tube (Upper).....			
Outlet Tube.....		∅A63004		Outlet Fitting To Trans. (Lower).....			
Tube Nut.....			④A63011	Outlet Tube (Lower).....			
<b>V-8 6.2 L DIESEL ENG.</b>				<b>1994-1991</b>			
Connector From Aux. Cooler.....			②A63017	<b>V-6 4.3 L ENG.</b>			
Inlet Fitting To Trans. (Upper).....			A63006	Inlet Fitting To Trans. (Upper).....			
Inlet Tube.....		∅A63004		Inlet Tube (Upper).....			
Outlet Fitting To Trans. (Lower).....			A63006	Outlet Fitting To Trans. (Lower).....			
Outlet Tube.....		∅A63004		Outlet Tube (Lower).....			
Tube Nut.....			●A63011	Tube Nut.....			
Wire Retainer (Connectors).....			●A63110	<b>1990</b>			
<b>R &amp; V SERIES PICKUP</b>				<b>4-CYL. 2.5 L ENG.</b>			
<b>1991-1989</b>				<b>1990</b>			
<b>V-8 5.7 L ENG.; V-8 6.2 L DIESEL ENG.; V-8 7.4 L ENG.</b>				<b>4-CYL. 2.5 L ENG.</b>			
Inlet (Upper).....		∅A63004		Inlet Fitting To Trans. (Upper).....			
Inlet Fitting To Trans. (Upper).....			A63006	Inlet Tube (Upper).....			
Outlet (Lower).....		∅A63004		Outlet Fitting To Trans. (Lower).....			
Outlet Fitting To Trans. (Lower).....			A63006	Outlet Tube (Lower).....			
Tube Nut.....			④A63011	Tube Nut.....			

② Two Required.      ④ Four Required.      ⑥ Six Required.      ∅ Cut To Fit.  
 ③ Three Required.      ⑤ Five Required.      ⑦ Seven Required.      ● As Required.

See Pages 1 - 10 for Engine Oil Cooler Applications.

## Transmission Oil Cooler Assemblies for Passenger Cars &amp; Light Trucks

Application	Assembly Number	Hoses & Tubes	Connectors & Fittings	Application	Assembly Number	Hoses & Tubes	Connectors & Fittings
<b>GMC - Continued</b>				<b>GMC - Continued</b>			
<b>SAFARI - Continued</b>				<b>SAVANA - Continued</b>			
<b>1990 - Continued</b>				<b>2002-2001</b>			
<b>V-6 4.3 L ENG.</b>				<b>V-6 4.3 L ENG.</b>			
Connector From Rad.; W/RWD .....			②A63006	Aux. Cooler Inlet (Upper);			
Inlet Fitting To Trans. (Upper) .....			A63006	W/17-Bolt Trans. Pan (MT1) .....	A61314		
Inlet Tube (Upper) .....	≠A63004			Connector From Rad.; W/16-Bolt			
Outlet Fitting To Trans. (Lower) .....			A63006	Trans. Pan (M30) .....			②A63018
Outlet Tube (Lower) .....	≠A63004			Connector From Rad.; W/17-Bolt			
Tube Nut .....			④A63011	Trans. Pan (MT1) .....			②A63006
				Inlet Fitting To Trans. (Upper);			
				W/16-Bolt Trans. Pan (M30) .....			A63021
				Inlet Fitting To Trans. (Upper);			
				W/17-Bolt Trans. Pan (MT1) .....			A63006
				Inlet Fitting To Trans. Case (Up-			
				per); W/17-Bolt Trans. Pan			A63027
				(MT1) .....			
				Outlet Fitting To Trans. (Lower);			A63021
				W/16-Bolt Trans. Pan (M30) .....			
				Outlet Fitting To Trans. (Lower);			A63006
				W/17-Bolt Trans. Pan (MT1) .....			
				Wire Retainer (Connectors & Fit-			●A63098
				tings) .....			
				<b>V-8 5.0 L ENG.</b>			
				Connector From Rad. ....			②A63018
				Inlet (Upper) .....	B61311		
				Inlet Fitting To Trans. (Upper) .....			A63021
				Outlet (Lower) .....	B61259		
				Outlet Fitting To Trans. (Lower) .....			A63021
				Wire Retainer (Connectors & Fit-			●A63098
				tings) .....			
				<b>V-8 5.7 L ENG.</b>			
				Aux. Cooler Inlet (Pass. Side);			
				W/17-Bolt Trans. Pan (MT1) .....	A61314		
				Aux. Cooler Outlet (Driver Side);			
				W/17-Bolt Trans. Pan (MT1) .....	B61261		
				Connector From Rad.; W/16-Bolt			
				Trans. Pan (M30) .....			②A63018
				Connector From Rad.; W/17-Bolt			②A63006
				Trans. Pan (MT1) .....			
				Inlet Fitting To Trans. (Upper);			A63021
				W/16-Bolt Trans. Pan (M30) .....			
				Inlet Fitting To Trans. (Upper);			A63027
				W/17-Bolt Trans. Pan (MT1) .....			
				Inlet From Rad. (Upper); W/16-Bolt			
				Trans. Pan (M30) .....	B61311		
				Inlet From Rad. (Upper); W/17-Bolt			
				Trans. Pan (MT1) .....	B61260		
				Outlet (Lower); W/16-Bolt Trans.			
				Pan (M30) .....	B61259		
				Outlet Fitting To Trans. (Lower) .....			A63021
				Wire Retainer (Connectors & Fit-			●A63098
				tings) .....			
				<b>V-8 6.5 L DIESEL ENG.; V-8 8.1 L ENG.</b>			
				Connector From Rad. ....			②A63006
				Inlet Fitting To Trans. (Upper) .....			A63021
				Inlet Fitting To Trans. Case (Up-			
				per) .....			A63027
				Outlet Fitting To Trans. (Lower) .....			A63021
				Wire Retainer (Fittings) .....			●A63098
				<b>2000-1998</b>			
				<b>V-6 4.3 L ENG.</b>			
				Aux. Cooler Inlet (Upper);			
				W/17-Bolt Trans. Pan (MT1) .....	A61314		
				Connector From Rad.; W/16-Bolt			
				Trans. Pan (M30) .....			②A63018
				Connector From Rad.; W/17-Bolt			②A63006
				Trans. Pan (MT1) .....			
				Inlet Fitting To Trans. (Upper);			A63021
				W/16-Bolt Trans. Pan (M30) .....			
				Inlet Fitting To Trans. (Upper);			A63006
				W/17-Bolt Trans. Pan (MT1) .....			

② Two Required.  
③ Three Required.

④ Four Required.  
⑤ Five Required.

⑥ Six Required.  
⑦ Seven Required.

≠ Cut To Fit.  
● As Required.

See Pages 1 - 10 for Engine Oil Cooler Applications.



# Transmission Oil Cooler Assemblies for Passenger Cars & Light Trucks

Application	Assembly Number	Hoses & Tubes	Connectors & Fittings	Application	Assembly Number	Hoses & Tubes	Connectors & Fittings
<b>GMC - Continued</b>				<b>GMC - Continued</b>			
<b>SAVANA - Continued</b>				<b>SAVANA - Continued</b>			
<b>2000-1998 - Continued</b>				<b>1997 - Continued</b>			
<b>V-6 4.3 L ENG. - Continued</b>				<b>V-6 4.3 L ENG. - Continued</b>			
Inlet Fitting To Trans. Case (Upper); W/17-Bolt Trans. Pan (MT1).....			A63027	Outlet Fitting To Trans. (Lower); W/16-Bolt Trans. Pan (M30).....			A63021
Outlet Fitting To Trans. (Lower); W/16-Bolt Trans. Pan (M30).....			A63021	Outlet Fitting To Trans. (Lower); W/17-Bolt Trans. Pan (MT1).....			A63006
Outlet Fitting To Trans. (Lower); W/17-Bolt Trans. Pan (MT1).....			A63006	Wire Retainer (Connectors & Fittings).....			●A63098
Wire Retainer (Connectors & Fittings).....			●A63098	<b>V-8 5.0 L ENG.</b>			
<b>V-8 5.0 L ENG.</b>				Connector From Rad. ....			
Connector From Rad. ....			②A63018	Inlet (Upper).....	B61269		A63021
Inlet (Upper).....	B61311		A63021	Inlet Fitting To Trans. (Upper).....	B61268		A63021
Inlet Fitting To Trans. (Upper).....			A63021	Outlet (Lower).....			A63021
Outlet (Lower).....	B61259		A63021	Outlet Fitting To Trans. (Lower).....			●A63098
Outlet Fitting To Trans. (Lower).....			●A63098	<b>V-8 5.7 L ENG.</b>			
Wire Retainer (Connectors & Fittings).....			●A63098	Aux. Cooler Inlet (Pass. Side); W/17-Bolt Trans. Pan (MT1).....			
<b>V-8 5.7 L ENG.</b>				Aux. Cooler Outlet (Driver Side); W/17-Bolt Trans. Pan (MT1).....			
Aux. Cooler Inlet (Pass. Side); W/17-Bolt Trans. Pan (MT1).....	A61314			Connector From Rad.; W/16-Bolt Trans. Pan (M30).....			②A63018
Aux. Cooler Outlet (Driver Side); W/17-Bolt Trans. Pan (MT1).....	B61261			Connector From Rad.; W/17-Bolt Trans. Pan (MT1).....			②A63006
Connector From Rad.; W/16-Bolt Trans. Pan (M30).....			②A63018	Inlet (Upper); W/16-Bolt Trans. Pan (M30).....	B61269		A63021
Connector From Rad.; W/17-Bolt Trans. Pan (MT1).....			②A63006	Inlet Fitting To Trans. (Upper); W/16-Bolt Trans. Pan (M30).....			A63021
Inlet Fitting To Trans. (Upper); W/16-Bolt Trans. Pan (M30).....			A63021	Inlet Fitting To Trans. (Upper); W/17-Bolt Trans. Pan (MT1).....			A63021
Inlet Fitting To Trans. (Upper); W/17-Bolt Trans. Pan (MT1).....			A63006	Inlet Fitting To Trans. Case (Upper); W/17-Bolt Trans. Pan (MT1).....			A63027
Inlet Fitting To Trans. Case (Upper); W/17-Bolt Trans. Pan (MT1).....			A63027	Inlet From Rad. (Upper); W/17-Bolt Trans. Pan (MT1).....	B61260 B61268		B61260 B61268
Inlet From Rad. (Upper); W/16-Bolt Trans. Pan (M30).....	B61311			Outlet (Lower).....			A63021
Inlet From Rad. (Upper); W/17-Bolt Trans. Pan (MT1).....	B61260			Outlet Fitting To Trans. (Lower); W/16-Bolt Trans. Pan (M30).....			A63021
Outlet (Lower); W/16-Bolt Trans. Pan (M30).....	B61259			Outlet Fitting To Trans. (Lower); W/17-Bolt Trans. Pan (MT1).....			A63006
Outlet Fitting To Trans. (Lower); W/16-Bolt Trans. Pan (M30).....			A63021	Wire Retainer (Connectors & Fittings).....			●A63098
Outlet Fitting To Trans. (Lower); W/17-Bolt Trans. Pan (MT1).....			A63006	<b>V-8 6.5 L DIESEL ENG.; V-8 7.4 L ENG.</b>			
Wire Retainer (Connectors & Fittings).....			●A63098	Connector From Rad. ....			
<b>V-8 6.5 L DIESEL ENG.; V-8 7.4 L ENG.</b>				Inlet Fitting To Trans. (Upper).....			
Connector From Rad. ....			②A63006	Inlet Fitting To Trans. Case (Upper).....			A63027
Inlet Fitting To Trans. (Upper).....			A63021	Outlet Fitting To Trans. (Lower).....			A63021
Inlet Fitting To Trans. Case (Upper).....			A63027	Wire Retainer (Fittings).....			●A63098
Outlet Fitting To Trans. (Lower).....			A63021	<b>1996</b>			
Wire Retainer (Fittings).....			●A63098	<b>V-6 4.3 L ENG.</b>			
<b>1997</b>				Aux. Cooler Inlet (Upper); W/17-Bolt Trans. Pan (MT1).....			
<b>V-6 4.3 L ENG.</b>				Connector From Rad.; W/16-Bolt Trans. Pan (M30).....			
Aux. Cooler Inlet (Upper); W/17-Bolt Trans. Pan (MT1).....	A61314			Connector From Rad.; W/17-Bolt Trans. Pan (MT1).....			②A63018
Connector From Rad.; W/16-Bolt Trans. Pan (M30).....			②A63018	Inlet Fitting To Trans. (Upper); W/16-Bolt Trans. Pan (M30).....			A63021
Connector From Rad.; W/17-Bolt Trans. Pan (MT1).....			②A63006	Inlet Fitting To Trans. (Upper); W/17-Bolt Trans. Pan (MT1).....			A63006
Inlet Fitting To Trans. (Upper); W/16-Bolt Trans. Pan (M30).....			A63021	Outlet Fitting To Trans. (Lower); W/16-Bolt Trans. Pan (M30).....			A63021
Inlet Fitting To Trans. (Upper); W/17-Bolt Trans. Pan (MT1).....			A63006	Outlet Fitting To Trans. (Lower); W/17-Bolt Trans. Pan (MT1).....			A63006
Inlet Fitting To Trans. Case (Upper); W/17-Bolt Trans. Pan (MT1).....			A63027	Wire Retainer (Connectors & Fittings).....			●A63098
Outlet Fitting To Trans. (Lower).....			A63021	<b>V-8 5.0 L ENG.</b>			
Wire Retainer (Fittings).....			●A63098	Connector From Rad. ....			

② Two Required.  
③ Three Required.

④ Four Required.  
⑤ Five Required.

⑥ Six Required.  
⑦ Seven Required.

✂ Cut To Fit.  
● As Required.

See Pages 1 - 10 for Engine Oil Cooler Applications.

## Transmission Oil Cooler Assemblies for Passenger Cars &amp; Light Trucks

Application	Assembly Number	Hoses & Tubes	Connectors & Fittings	Application	Assembly Number	Hoses & Tubes	Connectors & Fittings
<b>GMC - Continued</b>				<b>GMC - Continued</b>			
<b>SAVANA - Continued</b>				<b>SIERRA SERIES PICKUP - Continued</b>			
<b>1996 - Continued</b>				<b>2003 - Continued</b>			
<b>V-8 5.0 L ENG. - Continued</b>				<b>V-8 4.8 L ENG.</b>			
Inlet Fitting To Trans. (Upper).....			A63021	Aux. Cooler Inlet (Pass. Side).....	B61264		
Inlet Fitting To Trans. Case (Upper).....			A63007	Aux. Cooler Outlet (Driver Side).....	B61266		
Outlet Fitting To Trans. (Lower).....			A63021	Connector From Rad.; W/Aux. Cooler.....			●A63019
Wire Retainer (Connectors & Fittings).....			●A63098	Connector From Rad.; W/O Aux. Cooler.....			●A63018
<b>V-8 5.7 L ENG.</b>				Inlet (Upper); W/O Aux. Cooler.....	B61267		A63021
Aux. Cooler Inlet (Pass. Side); W/17-Bolt Trans. Pan (MT1).....	A61314			Inlet Fitting To Trans. (Upper).....			
Connector From Rad.; W/16-Bolt Trans. Pan (M30).....			②A63018	Outlet (Lower).....	B61262		A63006
Connector From Rad.; W/17-Bolt Trans. Pan (MT1).....			②A63006	Outlet Fitting To Trans. (Lower).....			
Inlet Fitting To Trans. (Upper); W/16-Bolt Trans. Pan (M30).....			A63021	<b>V-8 6.0 L ENG.</b>			
Inlet Fitting To Trans. (Upper); W/17-Bolt Trans. Pan (MT1).....			A63006	Aux. Cooler Inlet (Driver Side); W/16-Bolt Trans. Pan (M30).....	B61266		
Inlet Fitting To Trans. Case (Upper).....			A63007	Aux. Cooler Inlet (Driver Side); W/17-Bolt Trans. Pan (MT1).....	B61263		
Outlet Fitting To Trans. (Lower); W/16-Bolt Trans. Pan (M30).....			A63021	Aux. Cooler Inlet (Pass. Side); W/16-Bolt Trans. Pan (M30).....	B61264		
Outlet Fitting To Trans. (Lower); W/17-Bolt Trans. Pan (MT1).....			A63006	Aux. Cooler Outlet (Pass. Side); W/17-Bolt Trans. Pan (MT1).....	B61313		
Wire Retainer (Connectors & Fittings).....			●A63098	Connector From Aux. Cooler.....			②A63019
<b>V-8 6.5 L DIESEL ENG.</b>				Connector From Rad. ....			②A63018
Connector From Rad.; W/O Quick Connect Fitting.....			②A63006	Inlet (Upper); W/16-Bolt Trans. Pan (M30); W/O Aux. Cooler.....	B61267		A63027
Connector From Rad.; W/Quick Connect Fitting.....			②A63018	Inlet Fitting To Trans. (Lower).....			
Inlet Fitting To Trans. (Upper).....			A63006	Outlet (Lower); W/16-Bolt Trans. Pan (M30).....	B61262		
Outlet Fitting To Trans. (Lower).....			A63006	Outlet (Lower); W/17-Bolt Trans. Pan (MT1).....	B61312		
Wire Retainer (Fittings).....			●A63098	Quick Connect Tube Fitting (Lower).....			A63021
<b>V-8 7.4 L ENG.</b>				Quick Connect Tube Fitting (Upper).....			A63021
Connector From Rad.; W/Aux. Cooler.....			②A63018	Wire Retainer (Connectors & Fittings).....			●A63098
Connector From Rad.; W/O Aux. Cooler.....			②A63006	<b>V-8 6.6 L DIESEL ENG.</b>			
Inlet Fitting To Trans. (Upper); W/Aux. Cooler.....			A63018	Connector From Rad. ....			②A63067
Inlet Fitting To Trans. (Upper); W/O Aux. Cooler.....			A63006	<b>V-8 8.1 L ENG.</b>			
Inlet Fitting To Trans. Case (Upper); W/O Aux. Cooler.....			A63007	Connector From Aux. Cooler.....			②A63019
Outlet Fitting To Trans. (Lower); W/Aux. Cooler.....			A63018	Inlet Fitting To Trans. (Upper).....			A63021
Outlet Fitting To Trans. (Lower); W/O Aux. Cooler.....			A63006	Inlet From Rad. (Lower).....	B61270		
Outlet Fitting To Trans. Case (Lower); W/O Aux. Cooler.....			A63007	Outlet Fitting To Trans. (Lower).....			A63021
Wire Retainer (Fittings).....			●A63098	Wire Retainer (Connectors & Fittings).....			●A63098
<b>SIERRA SERIES PICKUP</b>				<b>2002</b>			
<b>2003</b>				<b>V-6 4.3 L ENG.; V-8 4.8 L ENG.; V-8 5.3 L ENG.</b>			
<b>V-6 4.3 L ENG.; V-8 5.3 L ENG.</b>				Aux. Cooler Inlet (Pass. Side).....	B61264		
Aux. Cooler Inlet (Pass. Side).....	B61264			Aux. Cooler Outlet (Driver Side).....	B61266		
Aux. Cooler Outlet (Driver Side).....	B61266			Connector From Rad.; W/Aux. Cooler.....			●A63019
Connector From Rad.; W/Aux. Cooler.....			●A63019	Connector From Rad.; W/O Aux. Cooler.....			●A63018
Connector From Rad.; W/O Aux. Cooler.....			●A63018	Inlet (Upper); W/O Aux. Cooler.....	B61267		A63021
Inlet (Upper); W/O Aux. Cooler.....	B61267			Inlet Fitting To Trans. (Upper).....			
Inlet Fitting To Trans. (Upper).....			A63021	Outlet (Lower).....	B61262		A63006
Outlet (Lower).....	B61262			Outlet Fitting To Trans. (Lower).....			A63006
Outlet Fitting To Trans. (Lower).....			A63006	Wire Retainer (Connectors & Fittings).....			●A63098
Wire Retainer (Connectors & Fittings).....			●A63098	<b>V-8 6.0 L ENG.</b>			
				Aux. Cooler Inlet (Driver Side); W/17-Bolt Trans. Pan (MT1).....	B61263		
				Aux. Cooler Inlet (Pass. Side); W/16-Bolt Trans. Pan (M30).....	B61264		
				Aux. Cooler Outlet (Driver Side); W/16-Bolt Trans. Pan (M30).....	B61266		
				Aux. Cooler Outlet (Pass. Side); W/17-Bolt Trans. Pan (MT1).....	B61313		
				Connector From Aux. Cooler.....			②A63019
				Connector From Rad. ....			②A63018

② Two Required.  
③ Three Required.

④ Four Required.  
⑤ Five Required.

⑥ Six Required.  
⑦ Seven Required.

∞ Cut To Fit.  
● As Required.

See Pages 1 - 10 for Engine Oil Cooler Applications.

# Transmission Oil Cooler Assemblies for Passenger Cars & Light Trucks

Application	Assembly Number	Hoses & Tubes	Connectors & Fittings	Application	Assembly Number	Hoses & Tubes	Connectors & Fittings
<b>GMC - Continued</b>				<b>GMC - Continued</b>			
<b>SIERRA SERIES PICKUP - Continued</b>				<b>SIERRA SERIES PICKUP - Continued</b>			
<b>2002 - Continued</b>				<b>2001 - Continued</b>			
<b>V-8 6.0 L ENG. - Continued</b>				<b>V-8 6.0 L ENG. - Continued</b>			
Inlet (Upper); W/O Aux. Cooler.....	B61267			Quick Connect Tube Fitting (Upper); W/17-Bolt Trans. Pan (MT1).....			A63021
Inlet Fitting To Trans. Case (Lower); W/17-Bolt Trans. Pan (MT1). Outlet (Lower); W/16-Bolt Trans. Pan (M30).....	B61262		A63027	Wire Retainer (Connectors & Fittings).....			●A63098
Outlet (Lower); W/17-Bolt Trans. Pan (MT1).....	B61312			<b>V-8 6.6 L DIESEL ENG.</b>			
Outlet Fitting To Trans. (Lower); W/16-Bolt Trans. Pan (M30).....			A63006	Connector From Aux. Cooler.....			②A63068
Quick Connect Tube Fitting (Lower); W/17-Bolt Trans. Pan (MT1). Quick Connect Tube Fitting (Upper).....			A63021	Connector From Rad. ....			②A63067
Wire Retainer (Connectors & Fittings).....			●A63098	Wire Retainer (Aux. Cooler) .....			②A63099
<b>V-8 6.6 L DIESEL ENG.</b>				<b>V-8 8.1 L ENG.</b>			
Connector From Aux. Cooler.....			②A63068	Connector From Aux. Cooler.....			②A63019
Connector From Rad. ....			②A63067	Inlet Fitting To Trans. (Upper).....			A63021
Wire Retainer (Aux. Cooler) .....			②A63099	Inlet From Rad. (Lower).....	B61270		
<b>V-8 8.1 L ENG.</b>				Outlet Fitting To Trans. (Lower).....			A63021
Connector From Aux. Cooler.....			②A63019	Wire Retainer (Connectors & Fittings).....			●A63098
Inlet Fitting To Trans. (Upper).....			A63021	<b>2000</b>			
Inlet From Rad. (Lower).....	B61270			<b>V-6 4.3 L ENG.; V-8 4.8 L ENG.</b>			
Outlet Fitting To Trans. (Lower).....			A63021	Aux. Cooler Inlet (Pass. Side).....	B61264		
Wire Retainer (Connectors & Fittings).....			●A63098	Aux. Cooler Outlet (Driver Side).....	B61266		
<b>2001</b>				Connector From Rad.; W/Aux. Cooler.....			●A63019
<b>V-6 4.3 L ENG.; V-8 4.8 L ENG.; V-8 5.3 L ENG.</b>				Connector From Rad.; W/O Aux. Cooler.....			●A63018
Aux. Cooler Inlet (Pass. Side).....	B61264			Inlet (Upper); W/O Aux. Cooler.....	B61267		
Aux. Cooler Outlet (Driver Side).....	B61266			Inlet Fitting To Trans. (Upper).....			A63021
Connector From Rad.; W/Aux. Cooler.....			●A63019	Outlet (Lower).....	B61262		
Connector From Rad.; W/O Aux. Cooler.....			●A63018	Outlet Fitting To Trans. (Lower).....			A63006
Inlet (Upper); W/O Aux. Cooler.....	B61267			Wire Retainer (Connectors & Fittings).....			●A63098
Inlet Fitting To Trans. (Upper).....			A63021	<b>V-8 5.3 L ENG.</b>			
Outlet (Lower).....	B61262			Aux. Cooler Inlet (Pass. Side); 1500, 3500 .....	B61264		
Outlet Fitting To Trans. (Lower).....			A63006	Aux. Cooler Inlet (Pass. Side); 2500.....	B61263		
Wire Retainer (Connectors & Fittings).....			●A63098	Aux. Cooler Outlet (Driver Side); 1500, 3500 .....	B61266		
<b>V-8 6.0 L ENG.</b>				Aux. Cooler Outlet (Driver Side); 2500.....	B61265		
Aux. Cooler Inlet (Driver Side); W/17-Bolt Trans. Pan (MT1) .....	B61263			Connector From Rad.; W/Aux. Cooler.....			●A63019
Aux. Cooler Inlet (Pass. Side); W/16-Bolt Trans. Pan (M30).....	B61264			Connector From Rad.; W/O Aux. Cooler.....			●A63018
Aux. Cooler Outlet (Driver Side); W/16-Bolt Trans. Pan (M30).....	B61266			Inlet (Upper); W/O Aux. Cooler.....	B61267		
Aux. Cooler Outlet (Pass. Side); W/17-Bolt Trans. Pan (MT1) .....	B61313			Inlet Fitting To Trans. (Upper).....			A63021
Connector From Aux. Cooler.....			②A63019	Outlet (Lower).....	B61262		
Connector From Rad. ....			②A63018	Outlet Fitting To Trans. (Lower).....			A63006
Inlet (Upper); W/O Aux. Cooler.....	B61267			Wire Retainer (Connectors & Fittings).....			●A63098
Inlet Fitting To Trans. Case (Lower); W/17-Bolt Trans. Pan (MT1). Outlet (Lower); W/16-Bolt Trans. Pan (M30).....	B61262		A63027	<b>V-8 6.0 L ENG.</b>			
Outlet (Lower); W/17-Bolt Trans. Pan (MT1).....	B61312			Aux. Cooler Inlet (Driver Side) .....	B61313		
Outlet Fitting To Trans. (Lower); W/16-Bolt Trans. Pan (M30).....			A63006	Aux. Cooler Supply From Rad. (Upper); 2nd Design .....	B61263		
Quick Connect Tube Fitting (Lower); W/16-Bolt Trans. Pan (M30). Quick Connect Tube Fitting (Lower); W/17-Bolt Trans. Pan (MT1). Quick Connect Tube Fitting (Upper); W/16-Bolt Trans. Pan (M30).....			A63021	Connector From Aux. Cooler.....			②A63019
			A63021	Connector From Rad. ....			②A63018
			A63021	Inlet Fitting To Trans. Case (Lower); 2500.....			A63027
			A63021	Outlet From Rad. (Lower); 2nd Design.....	B61312		
			A63021	Quick Connect Tube Fitting (Lower).....			A63021
			A63021	Quick Connect Tube Fitting (Upper).....			A63021
			A63021	Wire Retainer (Aux. Cooler) .....			●A63098

② Two Required.  
③ Three Required.

④ Four Required.  
⑤ Five Required.

⑥ Six Required.  
⑦ Seven Required.

✂ Cut To Fit.  
● As Required.

See Pages 1 - 10 for Engine Oil Cooler Applications.

## Transmission Oil Cooler Assemblies for Passenger Cars &amp; Light Trucks

Application	Assembly Number	Hoses & Tubes	Connectors & Fittings	Application	Assembly Number	Hoses & Tubes	Connectors & Fittings
<b>GMC - Continued</b>				<b>GMC - Continued</b>			
<b>SIERRA SERIES PICKUP - Continued</b>				<b>SIERRA SERIES PICKUP - Continued</b>			
<b>1999</b>				<b>1999 - Continued</b>			
<b>V-6 4.3 L ENG.; V-8 4.8 L ENG.</b>				<b>V-8 6.5 L DIESEL ENG. - Continued</b>			
Aux. Cooler Inlet (Pass. Side).....	B61264			Wire Retainer (Connectors & Fit- tings); W/3/8" Retainer.....			●A63098
Aux. Cooler Outlet (Driver Side).....	B61266			Wire Retainer (Connectors & Fit- tings); W/5/8" Retainer.....			●A63099
Connector From Rad.; W/Aux. Cooler.....			●A63019				
Connector From Rad.; W/O Aux. Cooler.....			●A63018				
Inlet (Upper); W/O Aux. Cooler.....	B61267		A63021				
Inlet Fitting To Trans. (Upper).....			A63006				
Outlet (Lower).....	B61262						
Outlet Fitting To Trans. (Lower).....			●A63098				
Wire Retainer (Connectors & Fit- tings).....							
<b>V-8 5.3 L ENG.</b>				<b>SONOMA</b>			
Aux. Cooler Inlet (Pass. Side); 1500, 3500.....	B61264			<b>2004</b>			
Aux. Cooler Inlet (Pass. Side); 2500.....	B61263			<b>V-6 4.3 L ENG.</b>			
Aux. Cooler Outlet (Driver Side); 1500, 3500.....	B61266			Inlet Fitting To Trans. (Lower).....			A63021
Aux. Cooler Outlet (Driver Side); 2500.....	B61265			Outlet Fitting To Trans. (Upper).....			A63021
Connector From Rad.; W/Aux. Cooler.....			●A63019	Wire Retainer (Connectors & Fit- tings).....			●A63098
Connector From Rad.; W/O Aux. Cooler.....			●A63018				
Inlet (Upper); W/O Aux. Cooler.....	B61267		A63021				
Inlet Fitting To Trans. (Upper).....			A63006				
Outlet (Lower).....	B61262						
Outlet Fitting To Trans. (Lower).....			●A63098				
Wire Retainer (Connectors & Fit- tings).....							
<b>V-8 6.0 L ENG.</b>				<b>2002</b>			
Aux. Cooler Inlet (Driver Side).....	B61313			<b>4-CYL. 2.2 L ENG.</b>			
Connector From Aux. Cooler.....			②A63019	Connector From Rad. ....			②A63018
Connector From Rad. ....			②A63018	Inlet Fitting To Trans. (Lower).....			A63021
Inlet Fitting To Trans. Case (Low- er).....			A63027	Outlet Fitting To Trans. (Upper).....			A63021
Quick Connect Tube Fitting (Low- er).....			A63021	Wire Retainer (Connectors & Fit- tings).....			●A63098
Quick Connect Tube Fitting (Up- per).....			A63021				
Wire Retainer (Aux. Cooler).....			●A63098	<b>V-6 4.3 L ENG.</b>			
<b>V-8 6.5 L DIESEL ENG.</b>				<b>2001-1998</b>			
Aux. Cooler Inlet (Pass. Side); 3500HD.....	A61027			<b>4-CYL. 2.2 L ENG.</b>			
Aux. Cooler Inlet (Pass. Side); Exc. 3500HD.....	A61028			Connector From Rad. ....			②A63018
Aux. Cooler Outlet (Driver Side); 3500HD.....	B61108			Inlet Fitting To Trans. (Lower).....			A63021
Aux. Cooler Outlet (Driver Side); Exc. 3500HD.....	B61107			Outlet Fitting To Trans. (Upper).....			A63021
Connector From Aux. Cooler.....			②A63019	Wire Retainer (Connectors & Fit- tings).....			●A63098
Inlet Fitting To Trans. (Upper); Ser- vice Item.....			A63007				
Inlet Fitting To Trans. (Upper); W/Factory Inst. Fitting.....			A63006	<b>V-6 4.3 L ENG.</b>			
Inlet Fitting To Trans. Case (Up- per); W/Factory Inst. Fitting.....			A63027	Connector From Rad. ....		B61042	②A63018
Inlet Tube (Upper); Service Item; Remove Current Line & Trans. Fittings. Replace Using Bulk Tubing & Service Item Listed.....		≡A63005		Inlet (Lower).....			A63021
Outlet Fitting To Trans. (Lower).....			A63006	Inlet Fitting To Trans. (Lower).....		B61043	A63021
Quick Connect Tube Fitting (Low- er).....			A63021	Outlet (Upper).....			A63021
Quick Connect Tube Fitting (Up- per).....			A63021	Outlet Fitting To Trans. (Upper).....			A63021
Tube Nut; Service Item.....			②A63013	Wire Retainer (Connectors & Fit- tings).....			●A63098

② Two Required.  
③ Three Required.

④ Four Required.  
⑤ Five Required.

⑥ Six Required.  
⑦ Seven Required.

≡ Cut To Fit.  
● As Required.

See Pages 1 - 10 for Engine Oil Cooler Applications.

## Transmission Oil Cooler Assemblies for Passenger Cars & Light Trucks

Application	Assembly Number	Hoses & Tubes	Connectors & Fittings	Application	Assembly Number	Hoses & Tubes	Connectors & Fittings
<b>GMC - Continued</b>				<b>GMC - Continued</b>			
<b>SONOMA - Continued</b>				<b>SUBURBAN - Continued</b>			
<b>1997-1996 - Continued</b>				<b>1999-1998 - Continued</b>			
<b>V-6 4.3 L ENG.</b>				<b>V-8 5.7 L ENG. - Continued</b>			
Connector From Rad.....			②A63018	Quick Connect Tube Fitting (Upper).....			A63021
Inlet (Lower).....	B61042			Tube Nut; Service Item.....			②A63013
Inlet Fitting To Trans. (Lower).....			A63021	Wire Retainer (Connectors & Fittings); W/3/8" Retainer.....			●A63098
Outlet (Upper).....	B61043			Wire Retainer (Connectors & Fittings); W/5/8" Retainer.....			●A63099
Outlet Fitting To Trans. (Upper).....			A63021				
Wire Retainer (Connectors & Fittings).....			●A63098				
<b>1995-1994</b>				<b>V-8 6.5 L DIESEL ENG.</b>			
<b>4-CYL. 2.2 L ENG.</b>				Aux. Cooler Inlet (Pass. Side)..... A61028			
Inlet (Lower).....		≠A63004		Aux. Cooler Outlet (Driver Side)..... B61107			
Inlet Fitting To Trans. (Lower).....			A63006	Connector From Aux. Cooler.....			②A63019
Outlet (Upper).....		≠A63004		Inlet Fitting To Trans. (Upper); Service Item.....			A63007
Outlet Fitting To Trans. (Upper).....			A63006	Inlet Fitting To Trans. (Upper); W/Factory Inst. Fitting.....			A63006
Tube Nut.....			④A63011	Inlet Fitting To Trans. Case (Upper); W/Factory Inst. Fitting.....			A63027
<b>V-6 4.3 L ENG.</b>				Inlet Tube (Upper); Service Item; Remove Current Line & Trans. Fittings. Replace Using Bulk Tubing & Service Item Listed..... ≠A63005			
Connector From Rad.....			②A63006	Outlet Fitting To Trans. (Lower).....			A63006
Inlet (Lower).....		≠A63004		Quick Connect Tube Fitting (Lower).....			A63021
Inlet Fitting To Trans. (Lower).....			A63006	Quick Connect Tube Fitting (Upper).....			A63021
Outlet (Upper).....		≠A63004		Tube Nut; Service Item.....			②A63013
Outlet Fitting To Trans. (Upper).....			A63006	Wire Retainer (Connectors & Fittings); W/3/8" Retainer.....			●A63098
Tube Nut.....			④A63011	Wire Retainer (Connectors & Fittings); W/5/8" Retainer.....			●A63099
<b>1993-1991</b>				<b>V-8 7.4 L ENG.</b>			
<b>4-CYL. 2.5 L ENG.; V-6 2.8 L ENG.; V-6 4.3 L ENG.</b>				Aux. Cooler Inlet (Pass. Side)..... B61025			
Inlet (Lower).....		≠A63004		Aux. Cooler Outlet (Driver Side)..... B61026			
Inlet Fitting To Trans. (Lower).....			A63006	Connector From Aux. Cooler.....			②A63019
Outlet (Upper).....		≠A63004		Inlet Fitting To Trans. (Upper); Service Item.....			A63007
Outlet Fitting To Trans. (Upper).....			A63006	Inlet Fitting To Trans. (Upper); W/Factory Inst. Fitting.....			A63006
Tube Nut.....			④A63011	Inlet Fitting To Trans. Case (Upper); W/Factory Inst. Fitting.....			A63027
<b>SUBURBAN</b>				Inlet Tube (Upper); Service Item; Remove Current Line & Trans. Fittings. Replace Using Bulk Tubing & Service Item Listed..... ≠A63005			
<b>1999-1998</b>				Outlet Fitting To Trans. (Lower).....			
<b>V-8 5.7 L ENG.</b>				Quick Connect Tube Fitting (Lower).....			
Aux. Cooler Inlet (Pass. Side); W/16-Bolt Trans. Pan (M30).....	B61056			Quick Connect Tube Fitting (Upper).....			A63021
Aux. Cooler Inlet (Pass. Side); W/17-Bolt Trans. Pan (MT1).....	A61028			Tube Nut; Service Item.....			②A63013
Aux. Cooler Outlet (Driver Side); W/16-Bolt Trans. Pan (M30).....	B61058			Wire Retainer (Connectors & Fittings); W/3/8" Retainer.....			●A63098
Aux. Cooler Outlet (Driver Side); W/17-Bolt Trans. Pan (MT1).....	B61029			Wire Retainer (Connectors & Fittings); W/5/8" Retainer.....			●A63099
Connector From Aux. Cooler.....			②A63019				
Inlet (Upper); W/O Aux. Cooler; W/16-Bolt Trans. Pan (M30).....	B61057						
Inlet Fitting To Trans. (Upper); Service Item.....			A63007				
Inlet Fitting To Trans. (Upper); W/16-Bolt Trans. Pan (M30).....			A63007				
Inlet Fitting To Trans. (Upper); W/Factory Inst. Fitting; W/17-Bolt Trans. Pan (MT1).....			A63006				
Inlet Fitting To Trans. Case (Upper); W/Factory Inst. Fitting; W/17-Bolt Trans. Pan (MT1).....			A63027				
Inlet Tube (Upper); Service Item; Remove Current Line & Trans. Fittings. Replace Using Bulk Tubing & Service Item Listed.....		≠A63005					
Outlet (Lower); W/O Aux. Cooler; W/16-Bolt Trans. Pan (M30).....	B61055						
Outlet Fitting To Trans. (Lower); W/16-Bolt Trans. Pan (M30).....			A63007				
Outlet Fitting To Trans. (Lower); W/17-Bolt Trans. Pan (MT1).....			A63006				
Quick Connect Tube Fitting (Lower).....			A63021				

② Two Required.  
③ Three Required.

④ Four Required.  
⑤ Five Required.

⑥ Six Required.  
⑦ Seven Required.

≠ Cut To Fit.  
● As Required.

See Pages 1 - 10 for Engine Oil Cooler Applications.

## Transmission Oil Cooler Assemblies for Passenger Cars &amp; Light Trucks

Application	Assembly Number	Hoses & Tubes	Connectors & Fittings	Application	Assembly Number	Hoses & Tubes	Connectors & Fittings
<b>GMC - Continued</b>				<b>GMC - Continued</b>			
<b>SUBURBAN - Continued</b>				<b>SUBURBAN - Continued</b>			
<b>1997 - Continued</b>				<b>1997 - Continued</b>			
V-8 5.7 L ENG. - Continued				V-8 7.4 L ENG. - Continued			
Inlet Fitting To Trans. (Upper); W/16-Bolt Trans. Pan (M30).....			A63007	Wire Retainer (Connectors & Fittings); W/3/8" Retainer.....			●A63098
Inlet Fitting To Trans. (Upper); W/Factory Inst. Fitting; W/17-Bolt Trans. Pan (MT1).....			A63006	Wire Retainer (Connectors & Fittings); W/5/8" Retainer.....			●A63099
Inlet Fitting To Trans. Case (Upper); W/Factory Inst. Fitting; W/17-Bolt Trans. Pan (MT1).....			A63027				
Inlet Tube (Upper); Service Item; Remove Current Line & Trans. Fittings. Replace Using Bulk Tubing & Service Item Listed.....		⊗A63005					
Outlet Fitting To Trans. (Lower); W/16-Bolt Trans. Pan (M30).....			A63007				
Outlet Fitting To Trans. (Lower); W/17-Bolt Trans. Pan (MT1).....			A63006				
Quick Connect Tube Fitting (Lower) .....			A63021				②A63019
Quick Connect Tube Fitting (Upper); W/Factory Inst. Fitting.....			A63021				A63007
Tube Nut; Service Item.....			A63021				A63007
Wire Retainer (Connectors & Fittings); W/3/8" Retainer.....			②A63013				A63006
Wire Retainer (Connectors & Fittings); W/5/8" Retainer.....			●A63098				A63006
			●A63099				
<b>V-8 6.5 L DIESEL ENG.</b>							
Aux. Cooler Inlet (Pass. Side).....	A61028						
Aux. Cooler Outlet (Driver Side).....	B61107						
Connector From Aux. Cooler.....			②A63019				A63007
Inlet Fitting To Trans. (Upper); Service Item.....			A63007				A63006
Inlet Fitting To Trans. (Upper); W/Factory Inst. Fitting.....			A63006				A63021
Inlet Fitting To Trans. Case (Upper); W/Factory Inst. Fitting.....			A63027				A63021
Inlet Tube (Upper); Service Item; Remove Current Line & Trans. Fittings. Replace Using Bulk Tubing & Service Item Listed.....		⊗A63005					②A63013
Outlet Fitting To Trans. (Lower).....			A63006				●A63098
Quick Connect Tube Fitting (Lower) .....			A63021				●A63099
Quick Connect Tube Fitting (Upper) .....			A63021				
Tube Nut; Service Item.....			②A63013				A63006
Wire Retainer (Connectors & Fittings); W/3/8" Retainer.....			●A63098				
Wire Retainer (Connectors & Fittings); W/5/8" Retainer.....			●A63099				
<b>V-8 7.4 L ENG.</b>							
Aux. Cooler Inlet (Pass. Side).....	B61025						
Aux. Cooler Outlet (Driver Side).....	B61026						
Connector From Aux. Cooler.....			②A63019				A63006
Inlet Fitting To Trans. (Upper); Service Item.....			A63007				A63021
Inlet Fitting To Trans. (Upper); W/Factory Inst. Fitting.....			A63006				A63021
Inlet Fitting To Trans. Case (Upper); W/Factory Inst. Fitting.....			A63027				②A63013
Inlet Tube (Upper); Service Item; Remove Current Line & Trans. Fittings. Replace Using Bulk Tubing & Service Item Listed.....		⊗A63005					●A63098
Outlet Fitting To Trans. (Lower).....			A63006				●A63099
Quick Connect Tube Fitting (Lower) .....			A63021				
Quick Connect Tube Fitting (Upper) .....			A63021				
Tube Nut; Service Item.....			②A63013				

② Two Required.  
③ Three Required.

④ Four Required.  
⑤ Five Required.

⑥ Six Required.  
⑦ Seven Required.

⊗ Cut To Fit.  
● As Required.

See Pages 1 - 10 for Engine Oil Cooler Applications.

# Transmission Oil Cooler Assemblies for Passenger Cars & Light Trucks

Application	Assembly Number	Hoses & Tubes	Connectors & Fittings	Application	Assembly Number	Hoses & Tubes	Connectors & Fittings
<b>GMC - Continued</b>				<b>GMC - Continued</b>			
<b>SUBURBAN - Continued</b>				<b>SUBURBAN - Continued</b>			
<b>1996 - Continued</b>				<b>1993 - Continued</b>			
<b>V-8 7.4 L ENG. - Continued</b>				<b>V-8 5.7 L ENG. - Continued</b>			
Inlet Tube (Upper); Service Item; Remove Current Line & Trans. Fittings. Replace Using Bulk Tubing & Service Item Listed.....		≠A63005		Inlet Fitting To Trans. (Upper).....			A63006
Outlet Fitting To Trans. (Lower).....			A63006	Outlet (Lower); W/O Aux. Cooler ....		≠A63004	
Quick Connect Tube Fitting (Low- er).....			A63021	Outlet Fitting To Trans. (Lower).....			A63006
Quick Connect Tube Fitting (Up- per).....			A63021	Tube Nut.....			●A63011
Tube Nut; Service Item.....			②A63013	Wire Retainer (Connectors).....			●A63110
Wire Retainer (Connectors & Fit- tings); W/3/8" Retainer.....			●A63098	<b>V-8 7.4 L ENG.</b>			
Wire Retainer (Connectors & Fit- tings); W/5/8" Retainer.....			●A63099	Aux. Cooler Inlet (Pass. Side).....	B61169		
<b>1995-1994</b>				Aux. Cooler Outlet (Driver Side).....	B61159		
<b>V-8 5.7 L ENG.</b>				Connector "O" Ring.....			●A63091
Aux. Cooler Inlet (Pass. Side); W/16-Bolt Trans. Pan (M30).....	A61217			Connector From Aux. Cooler.....			②A63017
Aux. Cooler Inlet (Pass. Side); W/17-Bolt Trans. Pan (MT1).....	A61172			Inlet (Upper).....		≠A63004	
Aux. Cooler Outlet (Driver Side); W/16-Bolt Trans. Pan (M30).....	B61211			Inlet (Upper); W/O Aux. Cooler.....		≠A63004	
Aux. Cooler Outlet (Driver Side); W/17-Bolt Trans. Pan (MT1).....	B61235			Inlet Fitting To Trans. (Upper).....			A63006
Connector "O" Ring.....			●A63091	Outlet Fitting To Trans. (Lower).....			●A63011
Connector From Aux. Cooler.....			②A63017	Tube Nut.....			●A63110
Inlet (Upper); W/Aux. Cooler.....			≠A63004	<b>1992</b>			
Inlet (Upper); W/O Aux. Cooler.....			≠A63004	<b>V-8 5.7 L ENG.; V-8 7.4 L ENG.</b>			
Inlet Fitting To Trans. (Upper).....			A63006	Inlet (Upper).....		≠A63004	
Outlet (Lower); W/O Aux. Cooler....			≠A63004	Inlet Fitting To Trans. (Upper).....			A63006
Outlet Fitting To Trans. (Lower).....			A63006	Outlet (Lower).....		≠A63004	
Tube Nut.....			●A63011	Outlet Fitting To Trans. (Lower).....			A63006
Wire Retainer (Connectors).....			●A63110	Tube Nut.....			④A63011
<b>V-8 6.5 L DIESEL ENG.</b>				<b>1991-1988</b>			
Aux. Cooler Inlet (Pass. Side).....	A61219			<b>V-8 5.7 L ENG.; V-8 6.2 L DIESEL ENG.; V-8 7.4 L ENG.</b>			
Aux. Cooler Outlet (Driver Side).....	B61165			Inlet (Upper).....		≠A63004	
Connector "O" Ring.....			●A63091	Inlet Fitting To Trans. (Upper).....			A63006
Connector From Aux. Cooler.....			②A63017	Outlet (Lower).....		≠A63004	
Inlet (Upper).....			≠A63004	Outlet Fitting To Trans. (Lower).....			A63006
Inlet Fitting To Trans. (Upper).....			A63006	Tube Nut.....			④A63011
Outlet Fitting To Trans. (Lower).....			A63006	<b>1987-1985</b>			
Tube Nut.....			●A63011	<b>V-8 5.0 L ENG.; V-8 5.7 L ENG.; V-8 6.2 L DIESEL ENG.;</b>			
Wire Retainer (Connectors).....			●A63110	<b>V-8 7.4 L ENG.</b>			
<b>V-8 7.4 L ENG.</b>				<b>V-8 5.0 L ENG.; V-8 5.7 L ENG.; V-8 6.2 L DIESEL ENG.;</b>			
Aux. Cooler Inlet (Pass. Side).....	B61169			Inlet (Upper).....		≠A63004	
Aux. Cooler Outlet (Driver Side).....	B61159			Inlet Fitting To Trans. (Upper).....			A63006
Connector "O" Ring.....			●A63091	Outlet (Lower).....		≠A63004	
Connector From Aux. Cooler.....			②A63017	Outlet Fitting To Trans. (Lower).....			A63006
Inlet (Upper).....			≠A63004	Tube Nut.....			④A63011
Inlet Fitting To Trans. (Upper).....			A63006	<b>SYCLONE</b>			
Outlet Fitting To Trans. (Lower).....			A63006	<b>1992-1991</b>			
Tube Nut.....			●A63011	<b>V-6 4.3 L ENG.</b>			
Wire Retainer (Connectors).....			●A63110	Inlet (Lower).....		≠A63004	
<b>1993</b>				Inlet Fitting To Trans. (Lower).....			A63006
<b>V-8 5.7 L ENG.</b>				Outlet (Upper).....		≠A63004	
Aux. Cooler Inlet (Pass. Side); W/16-Bolt Trans. Pan (M30).....	A61217			Outlet Fitting To Trans. (Upper).....			A63006
Aux. Cooler Inlet (Pass. Side); W/17-Bolt Trans. Pan (MT1).....	A61172			Tube Nut.....			④A63011
Aux. Cooler Outlet (Driver Side); W/16-Bolt Trans. Pan (M30).....	B61211			<b>TYPHOON</b>			
Aux. Cooler Outlet (Driver Side); W/17-Bolt Trans. Pan (MT1).....	B61235			<b>1993-1992</b>			
Connector "O" Ring.....			●A63091	<b>V-6 4.3 L ENG.</b>			
Connector From Aux. Cooler.....			②A63017	Inlet (Lower).....		≠A63004	
Inlet (Upper); W/Aux. Cooler.....			≠A63004	Inlet Fitting To Trans. (Lower).....			A63006
Inlet (Upper); W/O Aux. Cooler.....			≠A63004	Outlet (Upper).....		≠A63004	
<b>1993</b>				Outlet Fitting To Trans. (Upper).....			A63006
<b>V-8 5.7 L ENG.</b>				Tube Nut.....			④A63011
Aux. Cooler Inlet (Pass. Side); W/16-Bolt Trans. Pan (M30).....	A61217			<b>YUKON</b>			
Aux. Cooler Inlet (Pass. Side); W/17-Bolt Trans. Pan (MT1).....	A61172			<b>2003</b>			
Aux. Cooler Outlet (Driver Side); W/16-Bolt Trans. Pan (M30).....	B61211			<b>V-8 4.8 L ENG.; V-8 5.3 L ENG.</b>			
Aux. Cooler Outlet (Driver Side); W/17-Bolt Trans. Pan (MT1).....	B61235			Aux. Cooler Inlet (Pass. Side).....	B61264		
Connector "O" Ring.....			●A63091	Aux. Cooler Outlet (Driver Side).....	B61266		
Connector From Aux. Cooler.....			②A63017				
Inlet (Upper); W/Aux. Cooler.....			≠A63004				
Inlet (Upper); W/O Aux. Cooler.....			≠A63004				

② Two Required.  
③ Three Required.

④ Four Required.  
⑤ Five Required.

⑥ Six Required.  
⑦ Seven Required.

≠ Cut To Fit.  
● As Required.

See Pages 1 - 10 for Engine Oil Cooler Applications.

## Transmission Oil Cooler Assemblies for Passenger Cars &amp; Light Trucks

Application	Assembly Number	Hoses & Tubes	Connectors & Fittings	Application	Assembly Number	Hoses & Tubes	Connectors & Fittings
<b>GMC - Continued</b>				<b>GMC - Continued</b>			
<b>YUKON - Continued</b>				<b>YUKON - Continued</b>			
<b>2003 - Continued</b>				<b>2002-2001 - Continued</b>			
<b>V-8 4.8 L ENG.; V-8 5.3 L ENG. - Continued</b>				<b>V-8 6.0 L ENG. - Continued</b>			
Connector From Rad.; W/Aux.				Connector From Rad. ....			●A63018
Cooler .....			●A63019	Inlet (Upper); W/O Aux. Cooler .....	B61267		A63021
Connector From Rad.; W/O Aux.			●A63018	Inlet Fitting To Trans. (Lower) .....	B61262		A63021
Cooler .....			A63021	Outlet (Lower) .....			●A63098
Inlet (Upper); W/O Aux. Cooler .....	B61267		A63006	Outlet Fitting To Trans. (Upper) .....			●A63019
Inlet Fitting To Trans. (Upper) .....	B61262		●A63098	Wire Retainer (Connectors & Fittings) .....			②A63019
Outlet (Lower) .....				Connector From Rad. ....			②A63006
Outlet Fitting To Trans. (Lower) .....				Inlet Fitting To Trans. (Lower) .....			A63027
Wire Retainer (Connectors & Fittings) .....				Inlet From Rad. (Lower) .....	B61270		A63021
<b>V-8 6.0 L ENG.</b>				Quick Connect Tube Fitting (Lower) .....			A63021
Aux. Cooler Inlet (Driver Side);				Quick Connect Tube Fitting (Upper) .....			A63021
W/16-Bolt Trans. Pan (M30) .....	B61266			Wire Retainer (Connectors & Fittings) .....			●A63098
Aux. Cooler Inlet (Driver Side);							
W/17-Bolt Trans. Pan (MT1) .....	B61263			<b>2000</b>			
Aux. Cooler Inlet (Pass. Side);				<b>V-8 4.8 L ENG.; V-8 5.3 L ENG.</b>			
W/16-Bolt Trans. Pan (M30) .....	B61264			Aux. Cooler Inlet (Pass. Side);			
Aux. Cooler Inlet (Pass. Side);				1500 .....	B61264		
W/17-Bolt Trans. Pan (MT1) .....	B61313		②A63019	Aux. Cooler Inlet (Pass. Side);			
Connector From Aux. Cooler .....			●A63019	2500 .....	B61263		
Connector From Rad.; W/Aux.			②A63018	Aux. Cooler Outlet (Driver Side);			
Cooler .....			A63027	1500 .....	B61266		
Connector From Rad.; W/O Aux.			A63021	Aux. Cooler Outlet (Driver Side);			
Cooler .....				2500 .....	B61265		
Inlet (Upper); W/16-Bolt Trans. Pan				Connector From Rad.; W/Aux.			
(M30); W/O Aux. Cooler .....	B61267			Cooler .....			●A63019
Inlet Fitting To Trans. (Lower) .....			A63006	Connector From Rad.; W/O Aux.			●A63018
Inlet Fitting To Trans. (Upper) .....			A63021	Cooler .....			●A63018
Outlet (Lower); W/16-Bolt Trans.				Inlet (Upper); W/O Aux. Cooler .....	B61267		A63021
Pan (M30) .....	B61262			Inlet Fitting To Trans. (Upper) .....	B61262		A63006
Outlet (Lower); W/17-Bolt Trans.				Outlet (Lower) .....			●A63098
Pan (MT1) .....	B61312			Outlet Fitting To Trans. (Lower) .....			
Outlet Fitting To Trans. (Lower) .....				Wire Retainer (Connectors & Fittings) .....			
Quick Connect Tube Fitting (Lower) .....							
Quick Connect Tube Fitting (Upper) .....				<b>V-8 5.7 L ENG.</b>			
Wire Retainer (Connectors & Fittings) .....			●A63098	Aux. Cooler Inlet (Pass. Side) .....	B61056		
<b>V-8 8.1 L ENG.</b>				Aux. Cooler Outlet (Driver Side) .....	B61058		
Connector From Aux. Cooler .....			②A63019	Connector From Aux. Cooler .....			②A63019
Connector From Rad. ....			②A63019	Inlet (Upper); W/O Aux. Cooler .....	B61057		A63007
Inlet Fitting To Trans. (Lower) .....			A63027	Inlet Fitting To Trans. (Upper) .....			
Inlet From Rad. (Lower) .....	B61270			Outlet Fitting To Trans. (Lower) .....			A63006
Quick Connect Tube Fitting (Lower) .....				Wire Retainer (Connectors & Fittings) .....			●A63098
Quick Connect Tube Fitting (Upper) .....							
Wire Retainer (Connectors & Fittings) .....			●A63098	<b>V-8 6.0 L ENG.</b>			
<b>2002-2001</b>				Aux. Cooler Inlet (Driver Side) .....	B61313		
<b>V-8 4.8 L ENG.; V-8 5.3 L ENG.</b>				Aux. Cooler Supply From Rad.			
Aux. Cooler Inlet (Pass. Side) .....	B61264			(Upper); 2nd Design .....	B61263		②A63019
Aux. Cooler Outlet (Driver Side) .....	B61266			Connector From Rad. ....			②A63018
Connector From Rad.; W/Aux.				Inlet Fitting To Trans. Case (Lower) .....			A63027
Cooler .....							
Connector From Rad.; W/O Aux.							
Cooler .....							
Inlet (Upper); W/O Aux. Cooler .....	B61267						
Inlet Fitting To Trans. (Upper) .....	B61262						
Outlet (Lower) .....							
Outlet Fitting To Trans. (Lower) .....							
Wire Retainer (Connectors & Fittings) .....							
<b>V-8 6.0 L ENG.</b>							
Aux. Cooler Inlet (Driver Side) .....	B61263						
Aux. Cooler Outlet (Pass. Side) .....	B61312						
Connector From Aux. Cooler .....			②A63019				

② Two Required.  
③ Three Required.

④ Four Required.  
⑤ Five Required.

⑥ Six Required.  
⑦ Seven Required.

≠ Cut To Fit.  
● As Required.

See Pages 1 - 10 for Engine Oil Cooler Applications.



# Transmission Oil Cooler Assemblies for Passenger Cars & Light Trucks

Application	Assembly Number	Hoses & Tubes	Connectors & Fittings	Application	Assembly Number	Hoses & Tubes	Connectors & Fittings
<b>GMC - Continued</b>				<b>GMC - Continued</b>			
<b>YUKON - Continued</b>				<b>YUKON - Continued</b>			
<b>2000 - Continued</b>				<b>1997 - Continued</b>			
<b>V-8 6.0 L ENG. - Continued</b>				<b>V-8 5.7 L ENG. - Continued</b>			
Outlet Fitting To Trans. Case (Upper).....			A63021	Inlet Fitting To Trans. Case (Upper); W/Factory Inst. Fitting; W/17-Bolt Trans. Pan (MT1).....			A63027
Outlet From Rad. (Lower); 2nd Design.....	B61312		●A63098	Inlet Tube (Upper); Service Item; Remove Current Line & Trans. Fittings. Replace Using Bulk Tubing & Service Item Listed.....		≠A63005	
Wire Retainer (Aux. Cooler).....				Outlet Fitting To Trans. (Lower); W/16-Bolt Trans. Pan (M30).....			A63007
<b>1999-1998</b>				<b>1997 - Continued</b>			
<b>V-8 5.7 L ENG.</b>				<b>V-8 5.7 L ENG. - Continued</b>			
Aux. Cooler Inlet (Pass. Side); W/16-Bolt Trans. Pan (M30).....	B61056			Outlet Fitting To Trans. (Lower); W/17-Bolt Trans. Pan (MT1).....			A63006
Aux. Cooler Inlet (Pass. Side); W/17-Bolt Trans. Pan (MT1).....	A61028			Quick Connect Tube Fitting (Lower).....			A63021
Aux. Cooler Outlet (Driver Side); W/16-Bolt Trans. Pan (M30).....	B61058			Quick Connect Tube Fitting (Upper); W/Factory Inst. Fitting.....			A63021
Aux. Cooler Outlet (Driver Side); W/17-Bolt Trans. Pan (MT1).....	B61029			Tube Nut; Service Item.....			②A63013
Connector From Aux. Cooler.....			②A63019	Wire Retainer (Connectors & Fittings); W/3/8" Retainer.....			●A63098
Inlet (Upper); W/O Aux. Cooler; W/16-Bolt Trans. Pan (M30).....	B61057			Wire Retainer (Connectors & Fittings); W/5/8" Retainer.....			●A63099
Inlet Fitting To Trans. (Upper); Service Item.....			A63007	<b>V-8 6.5 L DIESEL ENG.</b>			
Inlet Fitting To Trans. (Upper); W/16-Bolt Trans. Pan (M30).....			A63007	Aux. Cooler Inlet (Pass. Side).....	A61028		
Inlet Fitting To Trans. (Upper); W/Factory Inst. Fitting; W/17-Bolt Trans. Pan (MT1).....			A63006	Aux. Cooler Outlet (Driver Side).....	B61107		
Inlet Fitting To Trans. Case (Upper); W/Factory Inst. Fitting; W/17-Bolt Trans. Pan (MT1).....			A63027	Connector From Aux. Cooler.....			②A63019
Inlet Tube (Upper); W/Aux. Cooler; Service Item; Remove Current Line & Trans. Fittings. Replace Using Bulk Tubing & Service Item Listed.....			≠A63005	Inlet Fitting To Trans. (Upper); Service Item.....			A63007
Outlet (Lower); W/O Aux. Cooler; W/16-Bolt Trans. Pan (M30).....	B61055			Inlet Fitting To Trans. Case (Upper); W/Factory Inst. Fitting.....			A63027
Outlet Fitting To Trans. (Lower); W/16-Bolt Trans. Pan (M30).....			A63007	Inlet Tube (Upper); Service Item; Remove Current Line & Trans. Fittings. Replace Using Bulk Tubing & Service Item Listed.....		≠A63005	
Outlet Fitting To Trans. (Lower); W/17-Bolt Trans. Pan (MT1).....			A63006	Outlet Fitting To Trans. (Lower).....			A63006
Quick Connect Tube Fitting (Lower).....			A63021	Quick Connect Tube Fitting (Lower).....			A63021
Quick Connect Tube Fitting (Upper).....			A63021	Quick Connect Tube Fitting (Upper).....			A63021
Tube Nut; Service Item.....			②A63013	Tube Nut; Service Item.....			②A63013
Wire Retainer (Connectors & Fittings); W/3/8" Retainer.....			●A63098	Wire Retainer (Connectors & Fittings); W/3/8" Retainer.....			●A63098
Wire Retainer (Connectors & Fittings); W/5/8" Retainer.....			●A63099	Wire Retainer (Connectors & Fittings); W/5/8" Retainer.....			●A63099
<b>1997</b>				<b>1996</b>			
<b>V-8 5.7 L ENG.</b>				<b>V-8 5.7 L ENG.</b>			
Aux. Cooler Inlet (Pass. Side); W/16-Bolt Trans. Pan (M30).....	B61240			Aux. Cooler Inlet (Pass. Side); W/16-Bolt Trans. Pan (M30).....	B61240		
Aux. Cooler Inlet (Pass. Side); W/17-Bolt Trans. Pan (MT1).....	A61028			Aux. Cooler Inlet (Pass. Side); W/16-Bolt Trans. Pan (M30).....	B61252		
Aux. Cooler Outlet (Driver Side); W/16-Bolt Trans. Pan (M30).....	B61252			Aux. Cooler Outlet (Driver Side); W/17-Bolt Trans. Pan (MT1).....	B61253		
Aux. Cooler Outlet (Driver Side); W/17-Bolt Trans. Pan (MT1).....	B61029			Connector From Aux. Cooler.....			②A63019
Connector From Aux. Cooler.....			②A63019	Inlet Fitting To Trans. (Upper); Service Item.....			A63007
Inlet Fitting To Trans. (Upper); Service Item.....			A63007	Inlet Fitting To Trans. (Upper); W/16-Bolt Trans. Pan (M30).....			A63007
Inlet Fitting To Trans. (Upper); W/16-Bolt Trans. Pan (M30).....			A63007	Inlet Fitting To Trans. (Upper); W/Factory Inst. Fitting; W/17-Bolt Trans. Pan (MT1).....			A63006
Inlet Fitting To Trans. (Upper); W/Factory Inst. Fitting; W/17-Bolt Trans. Pan (MT1).....			A63006	Inlet Tube (Upper); Service Item; Remove Current Line & Trans. Fittings. Replace Using Bulk Tubing & Service Item Listed.....		≠A63005	
				Outlet Fitting To Trans. (Lower); W/16-Bolt Trans. Pan (M30).....			A63007

② Two Required.  
③ Three Required.

④ Four Required.  
⑤ Five Required.

⑥ Six Required.  
⑦ Seven Required.

≠ Cut To Fit.  
● As Required.

See Pages 1 - 10 for Engine Oil Cooler Applications.

Product Section

Troubleshooting

EOC Applications

TOC Applications

Numerical Listing

Manufacturers' Part Numbers

End Fittings

Illustrations

## Transmission Oil Cooler Assemblies for Passenger Cars &amp; Light Trucks

Application	Assembly Number	Hoses & Tubes	Connectors & Fittings	Application	Assembly Number	Hoses & Tubes	Connectors & Fittings
<b>GMC - Continued</b>				<b>GMC - Continued</b>			
<b>YUKON - Continued</b>				<b>YUKON - Continued</b>			
<b>1996 - Continued</b>				<b>1993 - Continued</b>			
<b>V-8 5.7 L ENG. - Continued</b>				<b>V-8 5.7 L ENG. - Continued</b>			
Outlet Fitting To Trans. (Lower); W/17-Bolt Trans. Pan (MT1) .....			A63006	Aux. Cooler Outlet (Driver Side); W/17-Bolt Trans. Pan (MT1) .....	B61235		
Quick Connect Tube Fitting (Lower) .....			A63021	Connector "O" Ring.....			●A63091 ②A63017
Quick Connect Tube Fitting (Upper); W/Factory Inst. Fitting.....			A63021	Connector From Aux. Cooler.....		≠A63004	
Tube Nut; Service Item.....			②A63013	Inlet (Upper); W/Aux. Cooler .....		≠A63004	A63006
Wire Retainer (Connectors & Fittings); W/3/8" Retainer.....			●A63098	Inlet Fitting To Trans. (Upper).....		≠A63004	A63006
Wire Retainer (Connectors & Fittings); W/5/8" Retainer.....			●A63099	Outlet (Lower); W/O Aux. Cooler .....			A63006
				Outlet Fitting To Trans. (Lower) .....			●A63011 ●A63110
				Tube Nut.....			
				Wire Retainer (Connectors).....			
<b>V-8 6.5 L DIESEL ENG.</b>				<b>1992</b>			
Connector From Aux. Cooler.....			②A63019	<b>V-8 5.7 L ENG.</b>			
Inlet Fitting To Trans. (Upper); Service Item.....			A63007	Inlet (Upper).....		≠A63004	
Inlet Fitting To Trans. (Upper); W/Factory Inst. Fitting.....			A63006	Inlet Fitting To Trans. (Upper).....			A63006
Inlet Tube (Upper); Service Item; Remove Current Line & Trans. Fittings. Replace Using Bulk Tubing & Service Item Listed. ....		≠A63005		Outlet (Lower).....		≠A63004	
Outlet Fitting To Trans. (Lower) .....			A63006	Outlet Fitting To Trans. (Lower) .....			A63006
Quick Connect Tube Fitting (Lower) .....			A63021	Tube Nut.....			④A63011
Quick Connect Tube Fitting (Upper); W/Factory Inst. Fitting.....			A63021	<b>JEEP</b>			
Tube Nut; Service Item.....			②A63013	<b>CHEROKEE</b>			
Wire Retainer (Connectors & Fittings); W/3/8" Retainer.....			●A63098	<b>2001</b>			
Wire Retainer (Connectors & Fittings); W/5/8" Retainer.....			●A63099	<b>6-CYL. 4.0 L ENG.</b>			
				"O" Ring To Trans. ....			②A63096
				Aux. Cooler Inlet (Lower).....	A61139		
				Aux. Cooler Outlet (Upper) To Trans. (Rear).....	B61146		
				Inlet From Rad. Tube (Upper) To Trans. (Front).....	B61147		
				Rad. Inlet Tube (Upper).....	B61117		
<b>1995-1994</b>				<b>2000-1999</b>			
<b>V-8 5.7 L ENG.</b>				<b>4-CYL. 2.5 L ENG.</b>			
Aux. Cooler Inlet (Pass. Side); W/16-Bolt Trans. Pan (M30).....	A61217			Inlet Fitting To Trans.....			A63035
Aux. Cooler Inlet (Pass. Side); W/17-Bolt Trans. Pan (MT1) .....	A61172			Inlet Hose From Rad. (Lower).....	A61139		
Aux. Cooler Outlet (Driver Side); W/16-Bolt Trans. Pan (M30).....	B61211			Inlet Tube From Rad. (Upper).....	B61117		
Aux. Cooler Outlet (Driver Side); W/17-Bolt Trans. Pan (MT1) .....	B61235			Outlet Fitting To Trans.....			A63035
Connector "O" Ring.....			●A63091	<b>6-CYL. 4.0 L ENG.</b>			
Connector From Aux. Cooler.....			②A63017	"O" Ring To Trans. ....			②A63096
Inlet (Upper); W/Aux. Cooler .....		≠A63004		Aux. Cooler Inlet (Lower).....	A61139		
Inlet (Upper); W/O Aux. Cooler .....		≠A63004	A63006	Aux. Cooler Outlet (Upper) To Trans. (Rear).....	B61146		
Inlet Fitting To Trans. (Upper).....			A63006	Inlet From Rad. Tube (Upper) To Trans. (Front).....	B61147		
Outlet (Lower); W/O Aux. Cooler .....		≠A63004	●A63011	Rad. Inlet Tube (Upper).....	B61117		
Outlet Fitting To Trans. (Lower) .....			●A63110	<b>1998</b>			
Tube Nut.....				<b>4-CYL. 2.5 L ENG.</b>			
Wire Retainer (Connectors).....				Aux. Cooler Inlet (Lower).....	A61139		
				Inlet Fitting To Trans.....			A63035
				Inlet Hose From Rad. Tube (Up- per).....	A61121		
				Inlet Tube From Rad. (Upper).....	B61117		
				Inlet Tube To Trans. (Front).....	B61120		
				Outlet Fitting To Trans.....			A63035
				<b>6-CYL. 4.0 L ENG.</b>			
				"O" Ring To Trans. ....			②A63096
				Aux. Cooler Inlet (Lower).....	A61139		
				Aux. Cooler Outlet (Upper) To Trans. (Rear).....	B61146		
				Inlet From Rad. Tube (Upper) To Trans. (Front).....	B61147		
				Rad. Inlet Tube (Upper).....	B61117		

② Two Required.  
③ Three Required.

④ Four Required.  
⑤ Five Required.

⑥ Six Required.  
⑦ Seven Required.

≠ Cut To Fit.  
● As Required.

See Pages 1 - 10 for Engine Oil Cooler Applications.



## Transmission Oil Cooler Assemblies for Passenger Cars &amp; Light Trucks

Application	Assembly Number	Hoses & Tubes	Connectors & Fittings	Application	Assembly Number	Hoses & Tubes	Connectors & Fittings
<b>JEEP - Continued</b>				<b>JEEP - Continued</b>			
<b>GRAND CHEROKEE - Continued</b>				<b>GRAND CHEROKEE - Continued</b>			
<b>1997 - Continued</b>				<b>1993 - Continued</b>			
<b>V-8 5.2 L ENG. - Continued</b>				<b>V-8 5.2 L ENG. - Continued</b>			
Aux. Cooler Outlet Tube (Lower) ....	A61128			Inlet Fitting To Trans.....			A63032
Inlet Fitting To Trans. (Front) .....			A63035	Inlet Hose From Rad. (Lower).....	A61145		
Inlet Hose From Rad. (Lower).....	A61206			Inlet Tube (Lower) To Trans. (Front).....	B61144		
Inlet Tube From Rad. (Lower).....	A61118			Inlet Tube From Rad. (Lower) To Trans. (Front).....	A61114		
Inlet Tube From Rad. (Lower) To Trans. (Front) .....	B61207			Outlet Fitting To Trans.....			A63032
Outlet Fitting To Trans. (Rear).....			A63032	Outlet From Rad. (Upper) To Trans. (Rear).....	B61255		
Outlet From Rad. (Upper) To Trans. (Rear).....	B61210						
<b>1996</b>				<b>GRAND WAGONEER</b>			
<b>6-CYL. 4.0 L ENG.</b>				<b>1991-1990</b>			
Aux. Cooler Hose Elbow.....	②A61099			<b>V-8 5.9 L ENG.</b>			
Aux. Cooler Inlet Tube From Rad. (Upper) .....	A61125			Aux. Cooler Inlet Hose.....	A63001		
Aux. Cooler Outlet Tube (Lower) ....	A61126		A63032	Aux. Cooler Inlet Tube.....	∅A63004		
Inlet Fitting To Trans. (Front) .....				Aux. Cooler Outlet Tube.....	∅A63004		②A63041
Inlet Hose From Rad. (Upper).....	A61174			Connector From Rad. ....			
Inlet Tube From Rad. (Upper) To Trans. (Front) .....	B61173		A63032	Inlet Hose From Rad. ....	∅A63000		
Outlet Fitting To Trans. (Rear).....				Outlet Hose From Rad.....	∅A63000		
Outlet From Rad. (Lower) To Trans. (Rear).....	B61175			<b>1989-1987</b>			
Outlet Tube From Rad. (Upper); W/O Aux. Cooler.....	B61103			<b>V-8 5.9 L ENG.</b>			
<b>V-8 5.2 L ENG.</b>				Aux. Cooler Inlet Hose.....			
Aux. Cooler Hose Elbow.....	②A61099			Connector From Rad. ....			②A63041
Aux. Cooler Inlet Tube From Rad. (Upper) .....	B61127			Inlet Hose From Rad. ....	∅A63000		
Aux. Cooler Outlet Tube (Lower) ....	A61128		A63035	Outlet Hose From Rad.....	∅A63000		
Inlet Fitting To Trans. (Front) .....				<b>J SERIES PICKUP</b>			
Inlet Hose From Rad. (Lower).....	A61206			<b>1988</b>			
Inlet Tube From Rad. (Lower).....	A61118			<b>V-8 5.9 L ENG.</b>			
Inlet Tube From Rad. (Lower) To Trans. (Front) .....	B61207		A63032	Connector From Rad. ....			②A63041
Outlet Fitting To Trans. (Rear).....				Inlet Hose From Rad. ....	∅A63000		
Outlet From Rad. (Upper) To Trans. (Rear).....	B61210			Outlet Hose From Rad.....	∅A63000		
<b>1995-1994</b>				<b>1987</b>			
<b>6-CYL. 4.0 L ENG.</b>				<b>6-CYL. 4.2 L ENG.; V-8 5.9 L ENG.</b>			
Aux. Cooler Hose Elbow.....	②A61099			Connector From Rad. ....			②A63041
Aux. Cooler Inlet Tube From Rad. (Upper) .....	A61113			Inlet Hose From Rad. ....	∅A63000		
Aux. Cooler Outlet Tube (Lower) ....	B61051		A63032	Outlet Hose From Rad.....	∅A63000		
Inlet Fitting To Trans. (Front) .....				<b>WAGONEER</b>			
Outlet Fitting To Trans. (Rear).....			A63032	<b>1990-1988</b>			
Outlet Tube From Rad. (Upper); W/O Aux. Cooler.....	B61103			<b>6-CYL. 4.0 L ENG.</b>			
<b>V-8 5.2 L ENG.</b>				"O" Ring From Rad.....			
Aux. Cooler Hose Elbow.....	②A61099			Inlet Fitting To Trans.....			②A63096
Aux. Cooler Inlet Tube From Rad. (Upper) .....	B61127			Inlet From Rad. Tube (Upper) To Trans. (Front) .....	B61208		A63032
Aux. Cooler Outlet Tube (Lower) ....	A61128		A63032	Inlet Tube From Rad. (Upper).....	B61117		
Inlet Fitting To Trans.....				Outlet Fitting To Trans.....			A63032
Inlet Hose From Rad. (Lower).....	A61145			Outlet To Trans. (Rear) .....	B61122		
Inlet Tube (Lower) To Trans. (Front).....	B61144			<b>WRANGLER</b>			
Inlet Tube From Rad. (Lower).....	A61118		A63032	<b>2002-2001</b>			
Outlet Fitting To Trans.....				<b>4-CYL. 2.5 L ENG.</b>			
Outlet From Rad. (Upper) To Trans. (Rear).....	B61255			Inlet Fitting To Trans. (Front) .....			A63035
<b>1993</b>				Outlet Fitting To Trans. (Rear) .....			
<b>V-8 5.2 L ENG.</b>				A63032			
Aux. Cooler Hose Elbow.....	②A61099			<b>6-CYL. 4.0 L ENG.</b>			
Aux. Cooler Inlet Tube From Rad. (Upper) .....	B61127			Inlet Fitting To Trans.....			
Aux. Cooler Outlet Tube (Lower) ....	A61128			Outlet Fitting To Trans.....			
<b>2000</b>				A63032			
<b>V-8 5.2 L ENG.</b>				<b>4-CYL. 2.5 L ENG.; 6-CYL. 4.0 L ENG.</b>			
Aux. Cooler Hose Elbow.....	②A61099			Inlet Fitting To Trans.....			
Aux. Cooler Inlet Tube From Rad. (Upper) .....	B61127			A63032			
Aux. Cooler Outlet Tube (Lower) ....	A61128			A63032			

② Two Required.  
③ Three Required.

④ Four Required.  
⑤ Five Required.

⑥ Six Required.  
⑦ Seven Required.

∅ Cut To Fit.  
● As Required.

See Pages 1 - 10 for Engine Oil Cooler Applications.

# Transmission Oil Cooler Assemblies for Passenger Cars & Light Trucks

Application	Assembly Number	Hoses & Tubes	Connectors & Fittings	Application	Assembly Number	Hoses & Tubes	Connectors & Fittings
<b>JEEP - Continued</b>				<b>LINCOLN - Continued</b>			
<b>WRANGLER - Continued</b>				<b>CONTINENTAL - Continued</b>			
<b>2000 - Continued</b>				<b>1994-1990 - Continued</b>			
<b>4-CYL. 2.5 L ENG.; 6-CYL. 4.0 L ENG. - Continued</b>				<b>V-6 3.8 L ENG. - Continued</b>			
Outlet Fitting To Trans.....			A63032	Outlet Fitting To Trans.....			A63049
<b>1999-1997</b>				<b>1989</b>			
<b>4-CYL. 2.5 L ENG.</b>				<b>V-6 3.8 L ENG.</b>			
Inlet Fitting To Trans.....			A63032	"O" Ring (Connector & Fitting) .....			●A63094
Outlet Fitting To Trans.....			A63032	Connector From Rad. ....			②A63050
<b>6-CYL. 4.0 L ENG.</b>				Inlet Hose .....			
Outlet Fitting To Trans. (Rear) .....			A63032	Inlet Tube .....		⊗A63000	
<b>1995-1994</b>				Outlet Hose .....			
<b>4-CYL. 2.5 L ENG.</b>				Outlet Tube.....			
Aux. Cooler Hose Elbow (Upper)....	A61099			Tube Nut From Rad.....			②A63047
Inlet Fitting To Trans.....			A63032	Tube Nut To Trans. ....			②A63011
Inlet Hose (Driver Side) .....	A61136			<b>1988</b>			
Inlet Tube To Trans. (Front) .....	B61258			<b>V-6 3.8 L ENG.</b>			
Outlet Fitting To Trans.....			A63032	"O" Ring (Connector & Fitting) .....			
Outlet Tube (Pass. Side) To Trans. (Rear) .....	B61257			Connector From Rad. ....			
<b>6-CYL. 4.0 L ENG.</b>				Inlet Fitting To Trans.; W/Quick Connect Fitting; W/Factory Inst. Fitting.....			
Aux. Cooler Hose Elbow (Upper)....	A61099			Inlet Hose.....			
Inlet Fitting To Trans.....			A63032	Inlet Tube .....			
Outlet Fitting To Trans. (Rear); Service Item.....			A63035	Outlet Fitting To Trans.; W/Quick Connect Fitting; W/Factory Inst. Fitting.....			
Outlet Fitting To Trans. (Rear); W/Factory Inst. Fitting.....			A63032	Outlet Hose .....			
Outlet Hose (Pass. Side); Service Item.....		⊗A63001		Outlet Tube.....			
Outlet Tube (Pass. Side) To Trans. (Rear); Service Item.....		⊗A63005		Tube Nut From Rad.....			
<b>1993-1991</b>				Tube Nut To Trans. ....			
<b>4-CYL. 2.5 L ENG.; 6-CYL. 4.0 L ENG.</b>				<b>MARK VII</b>			
Connector From Rad. ....			②A63040	<b>1992-1989</b>			
Inlet Hose .....		⊗A63000		<b>V-8 5.0 L ENG.</b>			
Inlet Tube .....		⊗A63004		"O" Ring (Connector & Fitting) .....			
Outlet Hose .....		⊗A63000		Connector From Rad. ....			
Outlet Tube.....		⊗A63004		Inlet Hose .....			
<b>1990</b>				Inlet Tube .....			
<b>4-CYL. 2.5 L ENG.; 6-CYL. 4.2 L ENG.</b>				Outlet Hose .....			
Connector From Rad. ....			②A63040	Outlet Tube.....			
Inlet Hose (Driver Side) .....		⊗A63000		Tube Nut From Rad.....			
Outlet Hose (Pass. Side) .....		⊗A63000		Tube Nut To Trans. ....			
Outlet Tube (Pass. Side) .....		⊗A63004		<b>1988</b>			
<b>1989-1987</b>				<b>V-8 5.0 L ENG.</b>			
<b>4-CYL. 2.5 L ENG.; 6-CYL. 4.2 L ENG.</b>				"O" Ring (Connector & Fitting) .....			
Connector From Rad. ....			②A63040	Connector From Rad. ....			
Inlet Hose (Driver Side) .....		⊗A63000		Inlet Fitting To Trans.; W/Quick Connect Fitting; W/Factory Inst. Fitting.....			
Outlet Hose (Pass. Side) .....		⊗A63000		Inlet Hose .....			
Outlet Tube (Pass. Side) .....		⊗A63004		Inlet Tube .....			
<b>LINCOLN</b>				Outlet Fitting To Trans.; W/Quick Connect Fitting; W/Factory Inst. Fitting.....			
<b>CONTINENTAL</b>				Outlet Hose .....			
<b>2002-1995</b>				Outlet Tube.....			
<b>V-8 4.6 L ENG.</b>				Tube Nut From Rad.....			
Connector From Rad. ....			②A63050	Tube Nut To Trans. ....			
Inlet Fitting To Trans.....			A63076	<b>MARK VIII</b>			
Outlet Fitting To Trans.....			A63076	<b>1998-1996</b>			
<b>1994-1990</b>				<b>V-8 4.6 L ENG.</b>			
<b>V-6 3.8 L ENG.</b>				"O" Ring (Fitting).....			
Connector From Rad. ....			②A63049	Connector From Rad. ....			
Inlet Fitting To Trans.....			A63049	Inlet Tube .....			
Inlet To Trans. (Lower) .....	B61177			Outlet Tube.....			

② Two Required.  
③ Three Required.

④ Four Required.  
⑤ Five Required.

⑥ Six Required.  
⑦ Seven Required.

⊗ Cut To Fit.  
● As Required.

See Pages 1 - 10 for Engine Oil Cooler Applications.

## Transmission Oil Cooler Assemblies for Passenger Cars &amp; Light Trucks

Application	Assembly Number	Hoses & Tubes	Connectors & Fittings	Application	Assembly Number	Hoses & Tubes	Connectors & Fittings
<b>LINCOLN - Continued</b>				<b>LINCOLN - Continued</b>			
<b>MARK VIII - Continued</b>				<b>TOWN CAR - Continued</b>			
<b>1998-1996 - Continued</b>				<b>1995 - Continued</b>			
<b>V-8 4.6 L ENG. - Continued</b>				<b>V-8 4.6 L ENG. - Continued</b>			
Tube Nut; W/O Aux. Cooler .....			④A63011	Inlet Tube .....		≡A63004	
<b>1995-1993</b>				Outlet Hose .....		≡A63000	
<b>V-8 4.6 L ENG.</b>				Outlet Tube .....		≡A63004	
"O" Ring (Connector & Fitting) .....			●A63094	Tube Nut From Rad. ....			②A63047
Inlet Hose .....		≡A63000		Tube Nut To Trans. ....			②A63011
Inlet Tube .....		≡A63004		<b>1994-1991</b>			
Outlet Hose .....		≡A63000		<b>V-8 4.6 L ENG.</b>			
Outlet Tube .....		≡A63004		<b>"O" Ring (Connector &amp; Fitting) .....</b>			
Tube Nut From Rad. ....			②A63047	Inlet Hose .....		≡A63000	●A63094
Tube Nut To Trans. ....			②A63011	Inlet Tube .....		≡A63004	
<b>NAVIGATOR</b>				Outlet Hose .....		≡A63000	
<b>2002-2001</b>				Outlet Tube .....		≡A63004	
<b>V-8 5.4 L ENG.</b>				Tube Nut From Rad. ....			②A63047
"O" Ring (Connector) .....			●A63090	Tube Nut To Trans. ....			②A63011
By Pass Valve Washers (Front) .....			●A63105	<b>1990-1989</b>			
By Pass Valve Washers (Rear) .....			●A63106	<b>V-8 5.0 L ENG.</b>			
Inlet From Rad. (Lower); W/O Aux. Cooler .....	B61186			<b>"O" Ring (Connector &amp; Fitting) .....</b>			
Outlet From Rad. (Upper) .....	B61282			Connector From Rad. ....			●A63094
<b>2000-1998</b>				Inlet Hose .....		≡A63000	②A63050
<b>V-8 5.4 L ENG.</b>				Inlet Tube .....		≡A63004	
"O" Ring (Connector) .....			●A63090	Outlet Hose .....		≡A63000	
Aux. Cooler Inlet Tube Fitting (Pass. Side) .....	A61019			Outlet Tube .....		≡A63004	
Aux. Cooler Outlet (Driver Side) .....	B61193			Tube Nut From Rad. ....			②A63047
By Pass Valve Washers (Front) .....			●A63105	Tube Nut To Trans. ....			②A63011
By Pass Valve Washers (Rear) .....			●A63106	<b>1988</b>			
Inlet From Rad. (Lower); W/O Aux. Cooler .....	B61186			<b>V-8 5.0 L ENG.</b>			
Inlet To Trans. (Rear); W/Aux. Cooler .....	B61187			<b>"O" Ring (Connector) .....</b>			
Outlet From Rad. (Upper); W/Aux. Cooler .....	B61198			<b>"O" Ring (Fitting); Apr. 18 &amp; Newer</b>			
<b>TOWN CAR</b>				<b>Connector From Rad. ....</b>			
<b>2003-2000</b>				<b>Inlet Fitting To Trans.; Apr. 17 &amp; Older .....</b>			
<b>V-8 4.6 L ENG.</b>				<b>Inlet Hose .....</b>			
"O" Ring (Fitting) .....			●A63094	<b>Inlet Tube .....</b>			
Aux. Cooler Hose .....		≡A63000		<b>Outlet Fitting To Trans.; Apr. 17 &amp; Older .....</b>			
Inlet & Outlet Assy. ....	B61016			<b>Outlet Hose .....</b>			
<b>1999-1998</b>				<b>Outlet Tube .....</b>			
<b>V-8 4.6 L ENG.</b>				<b>Tube Nut From Rad. ....</b>			
"O" Ring (Fitting) .....			●A63094	<b>Tube Nut To Trans. ....</b>			
Aux. Cooler To Rad. (Upper) .....	B61182			<b>MERCURY</b>			
Aux. Cooler To Tube (Lower) .....	B61181			<b>CAPRI</b>			
Inlet & Outlet Assy. ....	B61016			<b>1994</b>			
<b>1997-1996</b>				<b>4-CYL. 1.6 L ENG.</b>			
<b>V-8 4.6 L ENG.</b>				<b>Banjo Washers From Pump .....</b>			
"O" Ring (Fitting) .....			●A63094	<b>Banjo Washers To Trans. ....</b>			
Aux. Cooler To Rad. (Upper) .....	B61182			<b>Inlet Hose .....</b>			
Aux. Cooler To Tube (Lower) .....	B61181			<b>Outlet Hose .....</b>			
Inlet To Trans. (Lower) .....	B61185			<b>1993-1991</b>			
Outlet To Trans. (Upper) .....	B61012			<b>4-CYL. 1.6 L ENG.</b>			
<b>1995</b>				<b>Inlet Hose .....</b>			
<b>V-8 4.6 L ENG.</b>				<b>Outlet Hose .....</b>			
"O" Ring (Connector & Fitting) .....			●A63094	<b>1991-1989</b>			
Aux. Cooler To Rad. (Upper) .....	B61182			<b>1991-1989</b>			
Aux. Cooler To Tube (Lower) .....	B61181			<b>V-8 5.0 L ENG.</b>			
Inlet Hose .....		≡A63000		<b>"O" Ring (Connector &amp; Fitting) .....</b>			
<b>② Two Required.</b>				<b>④ Four Required.</b>			
<b>③ Three Required.</b>				<b>⑤ Five Required.</b>			
				<b>⑥ Six Required.</b>			
				<b>⑦ Seven Required.</b>			
				<b>≡ Cut To Fit.</b>			
				<b>● As Required.</b>			

② Two Required.  
③ Three Required.

④ Four Required.  
⑤ Five Required.

⑥ Six Required.  
⑦ Seven Required.

≡ Cut To Fit.  
● As Required.

See Pages 1 - 10 for Engine Oil Cooler Applications.

# Transmission Oil Cooler Assemblies for Passenger Cars & Light Trucks

Application	Assembly Number	Hoses & Tubes	Connectors & Fittings	Application	Assembly Number	Hoses & Tubes	Connectors & Fittings
<b>MERCURY - Continued</b>				<b>MERCURY - Continued</b>			
<b>COLONY PARK - Continued</b>				<b>COUGAR - Continued</b>			
<b>1991-1989 - Continued</b>				<b>1990 - Continued</b>			
<b>V-8 5.0 L ENG. - Continued</b>				<b>V-6 3.8 L ENG. - Continued</b>			
Outlet Hose .....		↘A63000		Outlet (Pass. Side);			
Outlet Tube.....		↘A63004		W/Supercharger .....		↘A63004	
Tube Nut From Rad.....			②A63047	Tube Nut From Rad.;			②A63047
Tube Nut To Trans. ....			②A63011	W/Supercharger .....			②A63011
				Tube Nut To Trans.;			
				W/Supercharger .....			②A63011
<b>1988</b>				<b>1989</b>			
<b>V-8 5.0 L ENG.</b>				<b>V-6 3.8 L ENG.</b>			
"O" Ring (Connector) .....			②A63094	"O" Ring (Connector & Fitting) .....			●A63094
"O" Ring (Fitting); Apr. 18 & Newer			②A63094	Connector From Rad. ....			②A63050
Connector From Rad. ....			②A63050	Inlet Hose (Upper).....		↘A63000	
Inlet Fitting To Trans.; Apr. 17 &				Inlet Tube (Upper).....		↘A63004	
Older.....			A63049	Outlet Hose (Lower).....		↘A63000	
Inlet Hose .....		↘A63000		Outlet Tube (Lower).....		↘A63004	
Inlet Tube .....		↘A63004		Tube Nut From Rad.....			②A63047
Outlet Fitting To Trans.; Apr. 17 &				Tube Nut To Trans. ....			②A63011
Older.....			A63049				
Outlet Hose .....		↘A63000					
Outlet Tube.....		↘A63004					
Tube Nut From Rad.....			②A63047				
Tube Nut To Trans. ....			②A63011				
<b>COUGAR</b>				<b>1988</b>			
<b>1997-1996</b>				<b>V-6 3.8 L ENG.; V-8 5.0 L ENG.</b>			
<b>V-6 3.8 L ENG.; V-8 4.6 L ENG.</b>				<b>"O" Ring (Connector &amp; Fitting) .....</b>			
"O" Ring (Connector & Fitting) .....			●A63094	"O" Ring (Fitting); Apr. 18 & Newer			●A63094
Connector From Rad. ....			②A63050	Connector From Rad. ....			②A63050
Inlet (Upper).....		↘A63004		Inlet Fitting To Trans.; Apr. 17 &			A63049
Outlet (Lower).....		↘A63004		Older.....			A63049
Tube Nut From Rad.....			②A63047	Inlet Hose .....		↘A63000	
Tube Nut To Trans. ....			②A63011	Inlet Tube .....		↘A63004	
				Outlet Fitting To Trans.; Apr. 17 &			A63049
				Older.....			A63049
				Outlet Hose .....		↘A63000	
				Outlet Tube.....		↘A63004	
				Tube Nut From Rad.; W/4-Speed			
				Auto. Trans.....			②A63047
				Tube Nut To Trans. ....			②A63011
<b>1995-1994</b>				<b>GRAND MARQUIS</b>			
<b>V-6 3.8 L ENG.</b>				<b>2003-2000</b>			
"O" Ring (Connector & Fitting) .....			●A63094	<b>V-8 4.6 L ENG.</b>			
Connector From Rad. ....			②A63050	<b>Aux. Cooler Hose.....</b>			
Inlet (Upper).....	B61234			<b>Inlet &amp; Outlet Assy. ....</b>			
Outlet (Lower).....	B61176			B61016			
				<b>1999-1998</b>			
				<b>V-8 4.6 L ENG.</b>			
				<b>"O" Ring (Connector &amp; Fitting) .....</b>			
				<b>Connector From Rad. ....</b>			
				<b>Inlet &amp; Outlet Assy. ....</b>			
				B61016			
				<b>1997-1996</b>			
				<b>V-8 4.6 L ENG.</b>			
				<b>"O" Ring (Connector &amp; Fitting) .....</b>			
				<b>Aux. Cooler Inlet From Rad. (Up-</b>			
				<b>per) .....</b>			
				B61180			
				<b>Aux. Cooler Outlet (Lower).....</b>			
				B61179			
				<b>Connector From Rad. ....</b>			
				<b>Inlet To Trans. (Lower); W/Aux.</b>			
				<b>Cooler.....</b>			
				B61185			
				<b>Outlet To Trans. (Upper); W/Aux.</b>			
				<b>Cooler.....</b>			
				B61012			
				<b>1995-1992</b>			
				<b>V-8 4.6 L ENG.</b>			
				<b>"O" Ring (Connector &amp; Fitting) .....</b>			
				<b>Connector From Rad. ....</b>			
				<b>Inlet Hose .....</b>			
				<b>Inlet Tube .....</b>			
				<b>Outlet Hose .....</b>			
				<b>Outlet Tube.....</b>			
				B61234			
				B61176			

② Two Required.  
③ Three Required.

④ Four Required.  
⑤ Five Required.

⑥ Six Required.  
⑦ Seven Required.

↘ Cut To Fit.  
● As Required.

See Pages 1 - 10 for Engine Oil Cooler Applications.

Product Section

Troubleshooting

EOC Applications

TOC Applications

Numerical Listing

Manufacturers' Part Numbers

End Fittings

Illustrations

## Transmission Oil Cooler Assemblies for Passenger Cars &amp; Light Trucks

Application	Assembly Number	Hoses & Tubes	Connectors & Fittings	Application	Assembly Number	Hoses & Tubes	Connectors & Fittings
<b>MERCURY - Continued</b>				<b>MERCURY - Continued</b>			
<b>GRAND MARQUIS - Continued</b>				<b>MOUNTAINEER - Continued</b>			
<b>1995-1992 - Continued</b>				<b>1997 - Continued</b>			
<b>V-8 4.6 L ENG. - Continued</b>				<b>V-8 5.0 L ENG. - Continued</b>			
Tube Nut From Rad.....			●A63047	Inlet From Rad. (Lower).....	B61183		
Tube Nut To Trans.....			⊗A63011	Outlet From Rad. (Upper).....	B61184		
<b>1991-1990</b>				<b>MYSTIQUE</b>			
<b>V-8 5.0 L ENG.</b>				<b>1997</b>			
"O" Ring (Connector & Fitting).....			●A63094	<b>4-CYL. 2.0 L ENG.; V-6 2.5 L ENG.</b>			
Connector From Rad. ....			●A63050	"O" Ring (Fitting); Nov. 23 & Older.			⊗A63090
Inlet Hose.....		≠A63000		<b>1996-1995</b>			
Inlet Tube.....		≠A63004		<b>4-CYL. 2.0 L ENG.; V-6 2.5 L ENG.</b>			
Outlet Hose.....		≠A63000		"O" Ring (Fitting).....			⊗A63090
Outlet Tube.....		≠A63004		<b>SABLE</b>			
Tube Nut From Rad.....			●A63047	<b>2003-1999</b>			
Tube Nut To Trans.....			⊗A63011	<b>V-6 3.0 L ENG.</b>			
<b>1989</b>				<b>2003-1999</b>			
<b>V-8 5.0 L ENG.; V-8 5.8 L ENG. (CANADA)</b>				<b>V-6 3.0 L ENG.</b>			
"O" Ring (Connector & Fitting).....			●A63094	Inlet Fitting To Trans.....			A63076
Connector From Rad. ....			●A63050	Outlet Fitting To Trans.....			A63076
Inlet Hose.....		≠A63000		<b>1998-1997</b>			
Inlet Tube.....		≠A63004		<b>V-6 3.0 L ENG.</b>			
Outlet Hose.....		≠A63000		<b>V-6 3.0 L ENG.</b>			
Outlet Tube.....		≠A63004		<b>V-6 3.0 L ENG.</b>			
Tube Nut From Rad.....			●A63047	Inlet (Upper); W/Aux. Cooler;			
Tube Nut To Trans.....			⊗A63011	W/AX4N Trans. ....			
<b>1988</b>				A61014			
<b>V-8 5.0 L ENG.; V-8 5.8 L ENG. (CANADA)</b>				Inlet Fitting To Trans.....			
"O" Ring (Connector).....			⊗A63094	Outlet (Lower); W/Aux. Cooler;			
"O" Ring (Fitting); Apr. 18 & Newer			⊗A63094	W/AX4N Trans. ....			
Connector From Rad. ....			⊗A63050	A61069			
Inlet Fitting To Trans.; Apr. 17 &				Outlet (Lower); W/Aux. Cooler;			
Older.....			A63049	W/AX4S Trans. ....			
Inlet Hose.....		≠A63000		A61071			
Inlet Tube.....		≠A63004		Outlet Fitting To Trans.....			
Outlet Fitting To Trans.; Apr. 17 &				A63076			
Older.....			A63049	<b>1996</b>			
Outlet Hose.....		≠A63000		<b>V-6 3.0 L ENG.</b>			
Outlet Tube.....		≠A63004		Inlet (Lower); W/O Aux. Cooler;			
Tube Nut From Rad.....			⊗A63047	W/AX4S Trans. ....			
Tube Nut To Trans.....			⊗A63011	B61046			
<b>MOUNTAINEER</b>				Inlet (Upper); W/Aux. Cooler;			
<b>2002</b>				W/AX4S Trans. ....			
<b>V-6 4.0 L ENG.; V-8 4.6 L ENG.</b>				A61070			
"O" Ring (Connector & Fitting).....			⊗A63090	Inlet Fitting To Trans.....			
Aux. Cooler Hose.....		≠A63001		A63076			
<b>2001-1998</b>				<b>1995-1993</b>			
<b>V-6 4.0 L ENG.</b>				<b>V-6 3.0 L ENG.</b>			
"O" Ring (Connector & Fitting).....			⊗A63090	"O" Ring (Connector).....			
Aux. Cooler Hose.....		≠A63001		Aux. Cooler Supply Hose.....			
Aux. Cooler Outlet (Lower).....	B61279			Aux. Cooler Supply Tube (Lower)...			
Inlet From Rad. (Lower); W/O Aux.				B61178			
Cooler.....	B61277			Connector From Rad. ....			
Inlet To Trans. (Upper); W/Aux.				Inlet Fitting To Trans.....			
Cooler.....	B61278			Outlet Fitting To Trans.....			
Outlet To Trans. (Lower).....	B61280			<b>V-6 3.8 L ENG.</b>			
<b>V-8 5.0 L ENG.</b>				<b>"O" Ring (Connector).....</b>			
"O" Ring (Connector & Fitting).....			⊗A63090	Aux. Cooler Supply Hose; W/Police			
Aux. Cooler Hose.....		≠A63001		Pkg. ....			
Aux. Cooler Outlet (Lower).....	B61289			≠A63000			
Inlet To Trans. (Upper).....	B61288			Aux. Cooler Supply Tube (Lower);			
Outlet From Rad. (Upper).....	B61281			W/Police Pkg.....			
<b>1997</b>				B61178			
<b>V-8 5.0 L ENG.</b>				Connector From Rad. ....			
"O" Ring (Connector & Fitting).....			⊗A63090	Inlet Fitting To Trans.....			
<b>1992-1990</b>				Outlet Fitting To Trans.....			
<b>V-6 3.0 L ENG.</b>				<b>V-6 3.0 L ENG.</b>			
"O" Ring (Connector).....				"O" Ring (Connector).....			
<b>●A63094</b>				<b>●A63094</b>			

② Two Required.  
③ Three Required.

④ Four Required.  
⑤ Five Required.

⑥ Six Required.  
⑦ Seven Required.

≠ Cut To Fit.  
● As Required.

See Pages 1 - 10 for Engine Oil Cooler Applications.



## Transmission Oil Cooler Assemblies for Passenger Cars & Light Trucks

Application	Assembly Number	Hoses & Tubes	Connectors & Fittings	Application	Assembly Number	Hoses & Tubes	Connectors & Fittings
<b>MERCURY - Continued</b>				<b>MERCURY - Continued</b>			
<b>SABLE - Continued</b>				<b>TOPAZ - Continued</b>			
<b>1992-1990 - Continued</b>				<b>1994-1992 - Continued</b>			
<b>V-6 3.0 L ENG. - Continued</b>				<b>4-CYL. 2.3 L ENG. - Continued</b>			
Connector From Rad. ....			②A63050	Outlet Fitting To Trans.....			A63049
Inlet Fitting To Trans.....			A63049	Outlet Tube (Lower).....	∅A63004		
Outlet Fitting To Trans.....			A63049				
<b>V-6 3.8 L ENG.</b>				<b>V-6 3.0 L ENG.</b>			
"O" Ring (Connector).....			●A63094	Inlet Fitting To Trans.....			A63049
Aux. Cooler Supply Hose; W/Police Pkg.....		∅A63000		Inlet Hose (Upper).....	∅A63000		
Aux. Cooler Supply Tube (Lower); W/Police Pkg.....	B61178			Inlet Tube (Upper).....	∅A63004		
Connector From Rad. ....			②A63050	Outlet Fitting To Trans.....			A63049
Inlet (Upper).....	B61177			Outlet Hose (Lower).....	∅A63004		
Inlet Fitting To Trans.....			A63049	Outlet Tube (Lower).....	∅A63004		
Outlet Fitting To Trans.....			A63049				
<b>1989-1988</b>				<b>1991-1988</b>			
<b>V-6 3.0 L ENG.; V-6 3.8 L ENG.</b>				<b>4-CYL. 2.3 L ENG.</b>			
"O" Ring (Connector).....			●A63094	Inlet Fitting To Trans.....			A63049
Connector From Rad. ....			②A63050	Inlet Hose (Upper).....	∅A63000		
Inlet Fitting To Trans.; W/Factory Inst. Fitting.....			A63049	Inlet Tube (Upper).....	∅A63004		A63049
Inlet Hose (Upper).....		∅A63000		Outlet Fitting To Trans.....			
Inlet Tube (Upper).....		∅A63004		Outlet Tube (Lower).....	∅A63004		
Outlet Fitting To Trans.; W/Factory Inst. Fitting.....			A63049				
Outlet Hose (Lower); W/ATX Trans. ....		∅A63000					
Outlet Tube (Lower); W/ATX Trans. Tube Nut From Rad.; Service Item. Tube Nut To Trans.; Service Item...		∅A63004					
			②A63047				
			②A63011				
<b>1987</b>				<b>TRACER</b>			
<b>V-6 3.0 L ENG.</b>				<b>1999-1997</b>			
"O" Ring (Connector).....			●A63094	<b>4-CYL. 2.0 L ENG.</b>			
Connector From Rad. ....			②A63050	Banjo Washers; W/14mm I.D. Banjo.....			
Inlet Fitting To Trans.; W/Factory Inst. Fitting.....			A63049	Banjo Washers; W/16mm I.D. Banjo.....			
Inlet Hose (Upper).....		∅A63000		Outlet Hose .....			
Inlet Tube (Upper).....		∅A63004					
Outlet Fitting To Trans.; W/Factory Inst. Fitting.....			A63049				
Outlet Hose (Lower); W/ATX Trans. ....		∅A63000					
Outlet Tube (Lower); W/ATX Trans. Tube Nut From Rad.; Service Item. Tube Nut To Trans.; Service Item...		∅A63004					
			②A63047				
			②A63011				
<b>1986</b>				<b>1996-1991</b>			
<b>4-CYL. 2.5 L ENG.; V-6 3.0 L ENG.</b>				<b>4-CYL. 1.8 L ENG.; 4-CYL. 1.9 L ENG.</b>			
"O" Ring (Connector).....			●A63094	Banjo Washers; W/14mm I.D. Banjo.....			
Connector From Rad. ....			②A63050	Banjo Washers; W/16mm I.D. Banjo.....			
Inlet Fitting To Trans.; W/Factory Inst. Fitting.....			A63049	Outlet Hose .....			
Inlet Hose (Upper).....		∅A63000					
Inlet Tube (Upper).....		∅A63004					
Outlet Fitting To Trans.; W/Factory Inst. Fitting.....			A63049				
Outlet Hose (Lower); W/ATX Trans. ....		∅A63000					
Outlet Tube (Lower); W/ATX Trans. Tube Nut From Rad.; Service Item. Tube Nut To Trans.; Service Item...		∅A63004					
			②A63047				
			②A63011				
<b>1985</b>				<b>1989-1988</b>			
<b>4-CYL. 2.5 L ENG.; V-6 3.0 L ENG.</b>				<b>4-CYL. 1.6 L ENG.</b>			
"O" Ring (Connector).....			●A63094	"O" Ring (Connector & Fitting).....			
Connector From Rad. ....			②A63050	Connector From Rad.; W/Auto. Overdrive Trans. ....			
Inlet Fitting To Trans.; W/Factory Inst. Fitting.....			A63049	Inlet Fitting To Trans.; W/Factory Inst. Fitting.....			
Inlet Hose (Upper).....		∅A63000		Inlet Hose .....			
Inlet Tube (Upper).....		∅A63004		Inlet Tube .....			
Outlet Fitting To Trans.; W/Factory Inst. Fitting.....			A63049	Outlet Fitting To Trans.; W/Factory Inst. Fitting.....			
Outlet Hose (Lower); W/ATX Trans. ....		∅A63000		Outlet Hose .....			
Outlet Tube (Lower); W/ATX Trans. Tube Nut From Rad.; Service Item. Tube Nut To Trans.; Service Item...		∅A63004		Outlet Tube.....			
			②A63047	Tube Nut From Rad.; W/Auto. Overdrive Trans. ....			
			②A63011	Tube Nut To Trans.; Service Item...			
<b>1984</b>				<b>NISSAN</b>			
<b>4-CYL. 2.5 L ENG.; V-6 3.0 L ENG.</b>				<b>ALTIMA</b>			
"O" Ring (Connector).....			●A63094	<b>1998</b>			
Connector From Rad. ....			②A63050	<b>4-CYL. 2.4 L ENG.</b>			
Inlet Fitting To Trans.; W/Factory Inst. Fitting.....			A63049	Inlet (Driver Side); Jul. 31 & Older..			
Inlet Hose (Upper).....		∅A63000					
Inlet Tube (Upper).....		∅A63004					
Outlet Fitting To Trans.; W/Factory Inst. Fitting.....			A63049				
Outlet Hose (Lower); W/ATX Trans. ....		∅A63000					
Outlet Tube (Lower); W/ATX Trans. Tube Nut From Rad.; Service Item. Tube Nut To Trans.; Service Item...		∅A63004					
			②A63047				
			②A63011				
<b>1983</b>				<b>1997</b>			
<b>4-CYL. 2.5 L ENG.; V-6 3.0 L ENG.</b>				<b>4-CYL. 2.4 L ENG.</b>			
"O" Ring (Connector).....			●A63094	Inlet (Driver Side).....			
Connector From Rad. ....			②A63050				
Inlet Fitting To Trans.; W/Factory Inst. Fitting.....			A63049				
Inlet Hose (Upper).....		∅A63000					
Inlet Tube (Upper).....		∅A63004					
Outlet Fitting To Trans.; W/Factory Inst. Fitting.....			A63049				
Outlet Hose (Lower); W/ATX Trans. ....		∅A63000					
Outlet Tube (Lower); W/ATX Trans. Tube Nut From Rad.; Service Item. Tube Nut To Trans.; Service Item...		∅A63004					
			②A63047				
			②A63011				

② Two Required.      ④ Four Required.      ⑥ Six Required.      ∅ Cut To Fit.  
 ③ Three Required.      ⑤ Five Required.      ⑦ Seven Required.      ● As Required.

See Pages 1 - 10 for Engine Oil Cooler Applications.



## Transmission Oil Cooler Assemblies for Passenger Cars & Light Trucks

Application	Assembly Number	Hoses & Tubes	Connectors & Fittings	Application	Assembly Number	Hoses & Tubes	Connectors & Fittings
<b>OLDSMOBILE - Continued</b>				<b>OLDSMOBILE - Continued</b>			
<b>CUTLASS CALAIS</b>				<b>CUTLASS CIERA - Continued</b>			
<b>1991-1990</b>				<b>1993 - Continued</b>			
<b>4-CYL. 2.3 L ENG.; V-6 3.3 L ENG.</b>				<b>V-6 3.3 L ENG. - Continued</b>			
Inlet (Upper).....	A61225			Inlet Tube (Upper).....		④ A63004	
Inlet Fitting To Trans. (Upper).....			A63006	Outlet Hose (Lower).....		④ A63000	
Outlet (Lower).....	A61226			Outlet Tube (Lower).....		A63004	
Outlet Fitting To Trans. (Lower).....			A63006	Tube Nut.....			● A63011
<b>4-CYL. 2.5 L ENG.</b>				<b>1992-1990</b>			
Inlet (Upper).....	A61224			<b>4-CYL. 2.5 L ENG.</b>			
Inlet Fitting To Trans. (Upper).....			A63006	Inlet Fitting To Trans. (Upper).....			A63006
Outlet (Lower).....	A61248			Inlet Hose (Upper).....		④ A63000	
Outlet Fitting To Trans. (Lower).....			A63006	Inlet Tube (Upper).....		④ A63004	
<b>1989</b>				Outlet Fitting To Trans. (Lower).....		④ A63000	A63006
<b>4-CYL. 2.3 L ENG.; V-6 3.3 L ENG.</b>				Outlet Hose (Lower).....		④ A63000	
Inlet (Upper).....	A61223			Outlet Tube (Lower).....		A63004	
Inlet Fitting To Trans. (Upper).....			A63006	Tube Nut.....			● A63011
Outlet (Lower).....	A61222			<b>V-6 3.3 L ENG.</b>			
Outlet Fitting To Trans. (Lower).....			A63006	Inlet Fitting To Trans. (Upper).....			A63006
<b>4-CYL. 2.5 L ENG.</b>				Inlet Hose (Upper).....		④ A63000	
Inlet (Upper).....	A61223			Inlet Tube (Upper).....		④ A63004	
Inlet Fitting To Trans. (Upper).....			A63006	Outlet Hose (Lower).....		④ A63000	
Outlet (Lower).....	A61248			Outlet Tube (Lower).....		A63004	
Outlet Fitting To Trans. (Lower).....			A63006	Tube Nut.....			● A63011
<b>1988</b>				<b>1989</b>			
<b>4-CYL. 2.3 L ENG.; V-6 3.0 L ENG.</b>				<b>4-CYL. 2.5 L ENG.</b>			
Inlet (Upper).....	A61223			Inlet Fitting To Trans. (Upper).....			A63006
Inlet Fitting To Trans. (Upper).....			A63006	Inlet Hose (Upper).....		④ A63000	
Outlet (Lower).....	A61222			Inlet Tube (Upper).....		④ A63004	
Outlet Fitting To Trans. (Lower).....			A63006	Outlet Fitting To Trans. (Lower).....		④ A63000	A63006
<b>4-CYL. 2.5 L ENG.</b>				Outlet Hose (Lower).....		④ A63000	
Inlet (Upper).....	A61223			Outlet Tube (Lower).....		A63004	
Inlet Fitting To Trans. (Upper).....			A63006	Tube Nut.....			● A63011
Outlet (Lower).....	A61248			<b>V-6 2.8 L ENG.; V-6 3.3 L ENG.</b>			
Outlet Fitting To Trans. (Lower).....			A63006	Inlet Fitting To Trans. (Upper).....			A63006
<b>CUTLASS CIERA</b>				Inlet Hose (Upper).....		④ A63000	
<b>1996-1994</b>				Inlet Tube (Upper).....		④ A63004	
<b>4-CYL. 2.2 L ENG.</b>				Outlet Fitting To Trans. (Lower).....		④ A63000	A63006
Inlet Fitting To Trans. (Upper).....			A63006	Outlet Hose (Lower).....		④ A63004	
Inlet Hose (Upper).....		④ A63000		Outlet Tube (Lower).....		A63004	
Inlet Tube (Upper).....		④ A63004		Tube Nut.....			● A63011
Outlet Fitting To Trans. (Lower).....			A63006	<b>V-6 3.1 L ENG.</b>			
Outlet Hose (Lower).....		④ A63000		Inlet Fitting To Trans. (Upper).....			A63007
Outlet Tube (Lower).....		A63004		Inlet To Trans. (Upper).....	A61298		
Tube Nut.....			● A63011	Inlet Tube From Rad. (Upper).....		④ A63004	
<b>V-6 3.1 L ENG.</b>				Outlet Fitting To Trans. (Lower).....			A63008
Inlet Fitting To Trans. (Upper).....			A63007	Outlet To Trans. (Lower).....	A61299		
Inlet To Trans. (Upper).....	A61298			Outlet Tube From Rad. (Lower).....		④ A63004	
Inlet Tube From Rad. (Upper).....		④ A63004		Tube Nut.....			● A63011
Outlet Fitting To Trans. (Lower).....			A63008	<b>1993</b>			
Outlet To Trans. (Lower).....	A61299			<b>4-CYL. 2.2 L ENG.</b>			
Outlet Tube From Rad. (Lower).....		④ A63004		Inlet Fitting To Trans. (Upper).....			A63006
Tube Nut.....			● A63011	Inlet Hose (Upper).....		④ A63000	
<b>1993</b>				Inlet Tube (Upper).....		④ A63004	
<b>4-CYL. 2.2 L ENG.</b>				Outlet Fitting To Trans. (Lower).....			A63006
Inlet Fitting To Trans. (Upper).....			A63006	Outlet Hose (Lower).....		④ A63000	
Inlet Hose (Upper).....		④ A63000		Outlet Tube (Lower).....		A63004	
Inlet Tube (Upper).....		④ A63004		Tube Nut.....			● A63011
Outlet Fitting To Trans. (Lower).....			A63006	<b>V-6 3.3 L ENG.</b>			
Outlet Hose (Lower).....		④ A63000		Inlet Fitting To Trans. (Upper).....			A63006
Outlet Tube (Lower).....		A63004		Inlet To Trans. (Upper).....	A61298		
Tube Nut.....			● A63011	Inlet Tube From Rad. (Upper).....		④ A63004	
<b>V-6 3.3 L ENG.</b>				Outlet To Trans. (Lower).....	A61299		
Inlet Fitting To Trans. (Upper).....			A63006	<b>CUTLASS CRUISER</b>			
Inlet Hose (Upper).....		④ A63000		<b>1994</b>			
Inlet Tube (Upper).....		④ A63004		<b>V-6 3.1 L ENG.</b>			
Outlet Fitting To Trans. (Lower).....			A63006	Inlet Fitting To Trans. (Upper).....			A63006
Outlet Hose (Lower).....		④ A63000		Inlet To Trans. (Upper).....			
Outlet Tube (Lower).....		A63004		Inlet Tube From Rad. (Upper).....			
Tube Nut.....			● A63011	Outlet To Trans. (Lower).....			

② Two Required.      ④ Four Required.      ⑥ Six Required.      ✂ Cut To Fit.  
 ③ Three Required.    ⑤ Five Required.      ⑦ Seven Required.    ● As Required.

See Pages 1 - 10 for Engine Oil Cooler Applications.

## Transmission Oil Cooler Assemblies for Passenger Cars &amp; Light Trucks

Application	Assembly Number	Hoses & Tubes	Connectors & Fittings	Application	Assembly Number	Hoses & Tubes	Connectors & Fittings
<b>OLDSMOBILE - Continued</b>				<b>OLDSMOBILE - Continued</b>			
<b>CUTLASS CRUISER - Continued</b>				<b>CUTLASS SUPREME - Continued</b>			
<b>1994 - Continued</b>				<b>1993-1992 - Continued</b>			
<b>V-6 3.1 L ENG. - Continued</b>				<b>V-6 3.1 L ENG.; V-6 3.4 L ENG. - Continued</b>			
Outlet Tube From Rad. (Lower) .....		≠A63004	●A63011	Outlet To Trans. (Lower); W/4-Speed Trans. ....	A61030		
Tube Nut.....				Outlet Tube To Trans. (Lower); W/3-Speed Trans. ....		≠A63004	●A63013
<b>1993-1991</b>				<b>1991</b>			
<b>V-6 3.3 L ENG.</b>				<b>4-CYL. 2.3 L ENG.</b>			
Inlet Fitting To Trans. (Upper) .....			A63006	Aux. Cooler Inlet Tube (Upper) .....		≠A63004	
Inlet Hose (Upper).....		≠A63000		Aux. Cooler Outlet Tube (Lower) ...		≠A63004	A63006
Inlet Tube (Upper).....		≠A63004		Inlet Fitting To Trans. (Upper) .....			A63006
Outlet Hose (Lower).....		≠A63000		Inlet Hose (Upper).....		≠A63000	
Outlet Tube (Lower).....		A63004	●A63011	Inlet Tube To Trans. (Upper).....		≠A63004	A63006
Tube Nut.....				Outlet Fitting To Trans. (Lower) .....			A63006
<b>1990</b>				<b>V-6 3.1 L ENG.; V-6 3.4 L ENG.</b>			
<b>4-CYL. 2.5 L ENG.</b>				<b>V-6 3.1 L ENG.; V-6 3.4 L ENG.</b>			
Inlet Fitting To Trans. (Upper) .....			A63006	Inlet Fitting To Trans. (Upper); W/3-Speed Trans. ....			A63006
Inlet Hose (Upper).....		≠A63000		Inlet Fitting To Trans. (Upper); W/4-Speed Trans. ....			A63007
Inlet Tube (Upper).....		≠A63004		Inlet From Rad. (Upper); W/4-Speed Trans. ....		≠A63005	
Outlet Fitting To Trans. (Lower) .....			A63006	Inlet Hose (Upper); W/3-Speed Trans. ....		≠A63000	
Outlet Hose (Lower).....		≠A63000		Inlet To Trans. (Upper); W/4-Speed Trans. ....	A61031		
Outlet Tube (Lower).....		A63004	●A63011	Inlet Tube To Trans. (Upper); W/3-Speed Trans. ....		≠A63004	
Tube Nut.....				Outlet Fitting To Trans. (Lower); W/3-Speed Trans. ....			A63006
<b>V-6 3.3 L ENG.</b>				<b>V-6 3.1 L ENG.; V-6 3.4 L ENG.</b>			
Inlet Fitting To Trans. (Upper) .....			A63006	Outlet Fitting To Trans. (Lower); W/4-Speed Trans. ....			A63008
Inlet Hose (Upper).....		≠A63000		Outlet Hose (Lower); W/3-Speed Trans. ....		≠A63000	
Inlet Tube (Upper).....		≠A63004		Outlet To Trans. (Lower); W/4-Speed Trans. ....	A61030		
Outlet Hose (Lower).....		≠A63000		Outlet Tube To Trans. (Lower); W/3-Speed Trans. ....		≠A63004	●A63013
Outlet Tube (Lower).....		A63004	●A63011	Tube Nut; W/3-Speed Trans. ....			
Tube Nut.....				<b>1990</b>			
<b>CUTLASS SUPREME</b>				<b>4-CYL. 2.3 L ENG.</b>			
<b>1997</b>				<b>V-6 3.1 L ENG.</b>			
Inlet Fitting To Trans. (Upper) .....			A63007	Aux. Cooler Inlet Tube (Upper) .....		≠A63004	
Inlet To Trans. (Upper) .....	A61031			Aux. Cooler Outlet Tube (Lower) ...		≠A63004	A63006
Outlet Fitting To Trans. (Lower) .....			A63008	Inlet Fitting To Trans. (Upper) .....		≠A63000	
Outlet To Trans. (Lower) .....	A61030			Inlet Hose (Upper).....		≠A63004	A63006
<b>1996-1994</b>				<b>V-6 3.1 L ENG.; V-6 3.4 L ENG.</b>			
<b>V-6 3.1 L ENG.; V-6 3.4 L ENG.</b>				<b>V-6 3.1 L ENG.; V-6 3.4 L ENG.</b>			
Inlet Fitting To Trans. (Upper) .....			A63007	Inlet Tube To Trans. (Upper).....		≠A63000	
Inlet To Trans. (Upper) .....	A61031			Outlet Fitting To Trans. (Lower) .....		≠A63000	A63006
Outlet Fitting To Trans. (Lower) .....			A63008	Outlet Hose (Lower).....		≠A63004	
Outlet To Trans. (Lower) .....	A61030			Outlet Tube To Trans. (Lower).....		≠A63004	●A63011
<b>1993-1992</b>				<b>V-6 3.1 L ENG.</b>			
<b>V-6 3.1 L ENG.; V-6 3.4 L ENG.</b>				<b>V-6 3.1 L ENG.</b>			
Inlet Fitting To Trans. (Upper); W/3-Speed Trans. ....			A63006	Aux. Cooler Inlet Tube (Upper) .....		≠A63004	
Inlet Fitting To Trans. (Upper); W/4-Speed Trans. ....			A63007	Aux. Cooler Outlet Tube (Lower) ...		≠A63004	A63006
Inlet From Rad. (Upper); W/4-Speed Trans. ....		A63005		Inlet Fitting To Trans. (Upper) .....		≠A63000	
Inlet Hose (Upper); W/3-Speed Trans. ....		≠A63000		Inlet Hose (Upper).....		≠A63004	A63006
Inlet To Trans. (Upper); W/4-Speed Trans. ....	A61031			Inlet Tube To Trans. (Upper).....		≠A63000	
Inlet Tube To Trans. (Upper); W/3-Speed Trans. ....		≠A63004		Outlet Fitting To Trans. (Lower) .....		≠A63000	A63006
Outlet Fitting To Trans. (Lower); W/3-Speed Trans. ....			A63006	Outlet Hose (Lower).....		≠A63004	
Outlet Fitting To Trans. (Lower); W/4-Speed Trans. ....			A63008	Outlet Tube To Trans. (Lower).....		≠A63004	●A63011
Outlet From Rad. (Lower); W/4-Speed Trans. ....		≠A63005		Tube Nut.....			●A63013
Outlet Hose (Lower); W/3-Speed Trans. ....		≠A63000		<b>1989</b>			
Tube Nut.....				<b>V-6 2.8 L ENG.; V-6 3.1 L ENG.</b>			
<b>② Two Required.</b>				<b>④ Four Required.</b>			
<b>③ Three Required.</b>				<b>⑤ Five Required.</b>			
				<b>⑥ Six Required.</b>			
				<b>⑦ Seven Required.</b>			
				<b>≠ Cut To Fit.</b>			
				<b>● As Required.</b>			

See Pages 1 - 10 for Engine Oil Cooler Applications.

# Transmission Oil Cooler Assemblies for Passenger Cars & Light Trucks

Application	Assembly Number	Hoses & Tubes	Connectors & Fittings	Application	Assembly Number	Hoses & Tubes	Connectors & Fittings
<b>OLDSMOBILE - Continued</b>				<b>OLDSMOBILE - Continued</b>			
<b>CUTLASS SUPREME - Continued</b>				<b>EIGHTY EIGHT - Continued</b>			
<b>1989 - Continued</b>				<b>1996</b>			
<b>V-6 2.8 L ENG.; V-6 3.1 L ENG. - Continued</b>				<b>V-6 3.8 L ENG.</b>			
Inlet Hose (Upper).....		≈A63000		Aux. Cooler Outlet Tube (Upper) ....	A61271		
Inlet Tube To Trans. (Upper).....		≈A63004		Inlet (Upper); W/O Aux. Cooler.....	B61241		
Outlet Fitting To Trans. (Lower).....			A63006	Inlet Fitting To Trans. (Upper).....			A63007
Outlet Hose (Lower).....		≈A63000		Outlet (Lower).....	B61009		
Outlet Tube To Trans. (Lower).....		≈A63004		Outlet Fitting To Trans. (Lower).....			A63008
Tube Nut.....			●A63013				
<b>1988</b>				<b>1995-1994</b>			
<b>V-6 2.8 L ENG.; V-8 5.0 L ENG.</b>				<b>V-6 3.8 L ENG.</b>			
Inlet Fitting To Trans. (Upper).....			A63006	Aux. Cooler Outlet Tube (Upper) ....	A61271		
Inlet Hose (Upper).....		≈A63000		Inlet Fitting To Trans. (Upper).....			A63007
Inlet Tube (Upper).....		≈A63004		Inlet From Rad. (Upper); W/Aux. Cooler.....	B61110		
Outlet Fitting To Trans. (Lower).....			A63006	Inlet From Rad. (Upper); W/O Aux. Cooler.....	B61112		
Outlet Hose (Lower).....		≈A63000		Outlet Fitting To Trans. (Lower).....			A63008
Outlet Tube (Lower).....		≈A63004		Outlet From Rad. (Lower).....	B61111		
Tube Nut.....			●A63013				
<b>DELTA 88</b>				<b>1993</b>			
<b>1988</b>				<b>V-6 3.8 L ENG.</b>			
<b>V-6 3.8 L ENG.</b>				Aux. Cooler Outlet Tube (Upper) ....			
Inlet Fitting To Trans. (Upper).....			A63006	Inlet Fitting To Trans. (Lower).....	A61271		A63007
Inlet Hose From Rad. (Upper); W/Aux. Cooler.....	B61036			Inlet Fitting To Trans. (Upper).....			A63008
Inlet Tube From Rad. (Upper); W/O Aux. Cooler.....	B61032			Inlet From Rad. (Upper); W/Aux. Cooler.....	B61110		
Inlet Tube To Trans. (Upper).....	A61034			Inlet From Rad. (Upper); W/O Aux. Cooler.....	B61112		
Outlet Fitting To Trans. (Lower).....			A63006	Outlet Fitting To Trans. (Lower).....	A61274		
Outlet Hose To Trans. (Lower).....	A61035			Outlet Fitting To Trans. (Upper).....			A63007
Outlet Tube From Rad. (Lower); W/Aux. Cooler.....	B61037			Outlet From Rad. (Lower).....	B61244		A63008
Outlet Tube From Rad. (Lower); W/O Aux. Cooler.....	B61033			Outlet To Trans. (Upper).....	A61243		
Tube Nut.....			●A63011	Tube Nut.....			●A63013
Tube To Tube (Lower).....		≈A63000					
Tube To Tube (Upper).....		≈A63000		<b>1992</b>			
<b>1987-1986</b>				<b>V-6 3.8 L ENG.</b>			
<b>V-6 3.8 L ENG.</b>				Aux. Cooler Outlet Tube (Upper) ....			
Inlet (Upper).....	A61044			Inlet Fitting To Trans. (Lower).....	A61271		A63007
Inlet Fitting To Trans. (Upper).....			A63006	Inlet From Rad. (Upper); W/O Aux. Cooler.....	B61242		
Outlet (Lower).....	A61045			Inlet To Trans. (Lower); W/Aux. Cooler.....	B61245		
Outlet Fitting To Trans. (Lower).....			A63006	Outlet Fitting To Trans. (Upper).....			A63008
Tube Nut.....			●A63011	Outlet From Rad. (Lower).....	B61244		
<b>EIGHTY EIGHT</b>				Outlet To Trans. (Upper).....			
<b>1999-1998</b>				A61243			
<b>V-6 3.8 L ENG.</b>				<b>1991</b>			
<b>V-6 3.8 L ENG.</b>				<b>V-6 3.8 L ENG.</b>			
Inlet Fitting To Trans. (Upper).....			A63007	Aux. Cooler Outlet Tube (Upper) ....	A61271		A63007
Inlet From Rad. (Upper).....	B61112			Inlet Fitting To Trans. (Lower).....			
Outlet From Rad. (Lower).....	B61111			Inlet From Rad. (Upper); W/O Aux. Cooler.....	B61242		
<b>1997</b>				Inlet To Trans. (Lower); W/Aux. Cooler.....			
<b>V-6 3.8 L ENG.</b>				Inlet To Trans. (Lower); W/O Aux. Cooler.....			
Inlet Fitting To Trans. (Upper).....			A63007	Outlet Fitting To Trans. (Upper).....	A61274		A63008
Inlet From Rad. (Upper); Feb. 18 & Older.....	B61241			Outlet From Rad. (Lower).....	B61244		
Inlet From Rad. (Upper); Feb. 19 & Newer.....	B61112			Outlet To Trans. (Upper).....	A61243		
Outlet Fitting To Trans. (Lower).....			A63008	<b>1990-1989</b>			
Outlet From Rad. (Lower); Feb. 18 & Older.....	B61009			<b>V-6 3.8 L ENG.</b>			
Outlet From Rad. (Lower); Feb. 19 & Newer.....	B61111			Inlet Fitting To Trans. (Upper).....			
				Inlet Hose From Rad. (Upper); W/Aux. Cooler.....			
				Inlet Hose From Rad. (Upper); W/O Aux. Cooler.....			
				B61036			
				≈A63000			

② Two Required.  
③ Three Required.

④ Four Required.  
⑤ Five Required.

⑥ Six Required.  
⑦ Seven Required.

≈ Cut To Fit.  
● As Required.

See Pages 1 - 10 for Engine Oil Cooler Applications.

Product Section

Troubleshooting

EOC Applications

TOC Applications

Numerical Listing

Manufacturers' Part Numbers

End Fittings

Illustrations

## Transmission Oil Cooler Assemblies for Passenger Cars &amp; Light Trucks

Application	Assembly Number	Hoses & Tubes	Connectors & Fittings	Application	Assembly Number	Hoses & Tubes	Connectors & Fittings
<b>OLDSMOBILE - Continued</b>				<b>OLDSMOBILE - Continued</b>			
<b>EIGHTY EIGHT - Continued</b>				<b>INTRIGUE - Continued</b>			
<b>1990-1989 - Continued</b>				<b>1998</b>			
<b>V-6 3.8 L ENG. - Continued</b>				<b>V-6 3.8 L ENG.</b>			
Inlet Tube From Rad. (Upper); W/O Aux. Cooler.....	B61032			Aux. Cooler Inlet (Upper).....	B61237		
Inlet Tube To Trans. (Upper).....	A61034			Aux. Cooler Outlet (Lower).....	A61236		
Outlet Hose To Trans. (Lower).....	A61035			Connector From Rad. ....			②A63018
Outlet Tube From Rad. (Lower); W/Aux. Cooler.....	B61037			Inlet (Upper); W/O Aux. Cooler .....	B61239		A63007
Outlet Tube From Rad. (Lower); W/O Aux. Cooler.....	B61033			Inlet Fitting To Trans. (Upper).....			
				Inlet To Trans. (Upper); W/Aux. Cooler.....	A61031		
				Outlet (Lower); W/O Aux. Cooler ...	B61238		
				Outlet Fitting To Trans. (Lower); W/Check Ball.....			A63008
				Outlet To Trans. (Lower); W/Aux. Cooler.....	A61030		
<b>FIRENZA</b>				<b>NINETY EIGHT</b>			
<b>1988</b>				<b>1996</b>			
<b>4-CYL. 2.0 L ENG.</b>				<b>V-6 3.8 L ENG.</b>			
Inlet (Upper) .....	A61230		A63006	Inlet (Upper) .....	B61241		A63007
Inlet Fitting To Trans. (Upper).....				Inlet Fitting To Trans. (Upper).....			
Outlet (Lower).....	A61150		A63006	Outlet (Lower).....	B61009		A63008
Outlet Fitting To Trans. (Lower) .....				Outlet Fitting To Trans. (Lower) .....			
<b>1987</b>				<b>1995-1994</b>			
<b>4-CYL. 2.0 L ENG.</b>				<b>V-6 3.8 L ENG.</b>			
Inlet (Upper) .....	A61230		A63006	Aux. Cooler Outlet Tube (Upper) ....	A61271		A63007
Inlet Fitting To Trans. (Upper).....				Inlet Fitting To Trans. (Upper).....			
Outlet (Lower).....	A61150		A63006	Inlet From Rad. (Upper); W/Aux. Cooler.....	B61110		
Outlet Fitting To Trans. (Lower) .....				Inlet From Rad. (Upper); W/O Aux. Cooler.....	B61112		A63008
<b>V-6 2.8 L ENG.</b>				Outlet Fitting To Trans. (Lower) .....			
Inlet (Upper) .....	A61231		A63006	Outlet From Rad. (Lower).....	B61111		●A63013
Inlet Fitting To Trans. (Upper).....				Tube Nut.....			
Outlet (Lower).....	A61249		A63006	<b>1993</b>			
Outlet Fitting To Trans. (Lower) .....				<b>V-6 3.8 L ENG.</b>			
<b>1986-1985</b>				Aux. Cooler Outlet Tube (Upper) ....			
<b>4-CYL. 1.8 L ENG.; 4-CYL. 2.0 L ENG.</b>				Inlet Fitting To Trans. (Upper).....			
Inlet (Upper) .....	A61230		A63006	Inlet From Rad. (Upper); W/Aux. Cooler.....	B61110		
Inlet Fitting To Trans. (Upper).....				Inlet From Rad. (Upper); W/O Aux. Cooler.....	B61112		
Outlet (Lower).....	A61150		A63006	Inlet To Trans. (Lower); W/O Aux. Cooler.....	A61274		A63008
Outlet Fitting To Trans. (Lower) .....				Outlet Fitting To Trans. (Lower) .....			
<b>V-6 2.8 L ENG.</b>				Outlet From Rad. (Lower).....			
Inlet (Upper) .....	A61231		A63006	Tube Nut.....			●A63013
Inlet Fitting To Trans. (Upper).....				<b>1992-1991</b>			
Outlet (Lower).....	A61249		A63006	<b>V-6 3.8 L ENG.</b>			
Outlet Fitting To Trans. (Lower) .....				Aux. Cooler Outlet Tube (Upper) ....			
<b>INTRIGUE</b>				Inlet Fitting To Trans. (Lower).....			
<b>2002-2000</b>				Inlet From Rad. (Upper); W/O Aux. Cooler.....			
<b>V-6 3.5 L ENG.</b>				Inlet To Trans. (Lower); W/Aux. Cooler.....			
Connector From Rad. ....			②A63018	Inlet To Trans. (Lower); W/O Aux. Cooler.....	B61245		
Inlet Fitting To Trans. (Upper).....			A63021	Outlet Fitting To Trans. (Upper) .....			A63008
Outlet Fitting To Trans. (Lower).....			A63064	Outlet From Rad. (Lower).....	B61244		A63008
Wire Retainer (Connectors & Fit- tings).....			④A63098	Outlet To Trans. (Upper) .....	A61243		
<b>1999</b>				<b>1990-1988</b>			
<b>V-6 3.5 L ENG.</b>				<b>V-6 3.8 L ENG.</b>			
Connector From Rad. ....			②A63018	Inlet Fitting To Trans. (Upper).....			
Inlet Fitting To Trans. (Upper).....			A63007	Inlet Hose From Rad. (Upper); W/Aux. Cooler.....			
Outlet Fitting To Trans. (Lower); W/Check Ball.....			A63008	B61036			
Wire Retainer (Connectors).....			②A63098				
<b>V-6 3.8 L ENG.</b>							
Connector From Rad. ....			②A63018				
Inlet (Upper) .....	B61239		A63007				
Inlet Fitting To Trans. (Upper).....							
Outlet (Lower).....	B61238		A63008				
Outlet Fitting To Trans. (Lower); W/Check Ball.....			A63008				

② Two Required.  
③ Three Required.

④ Four Required.  
⑤ Five Required.

⑥ Six Required.  
⑦ Seven Required.

✂ Cut To Fit.  
● As Required.

See Pages 1 - 10 for Engine Oil Cooler Applications.

# Transmission Oil Cooler Assemblies for Passenger Cars & Light Trucks

Application	Assembly Number	Hoses & Tubes	Connectors & Fittings	Application	Assembly Number	Hoses & Tubes	Connectors & Fittings
<b>OLDSMOBILE - Continued</b>				<b>OLDSMOBILE - Continued</b>			
<b>NINETY EIGHT - Continued</b>				<b>SILHOUETTE - Continued</b>			
<b>1990-1988 - Continued</b>				<b>1995 - Continued</b>			
<b>V-6 3.8 L ENG. - Continued</b>				<b>V-6 3.8 L ENG. - Continued</b>			
Inlet Hose From Rad. (Upper); W/O Aux. Cooler.....			≈A63000	Outlet From Rad. (Lower); W/Aux. Cooler.....			≈A63005
Inlet Tube From Rad. (Upper); W/O Aux. Cooler.....	B61032			Outlet To Trans. (Upper); W/Aux. Cooler.....			≈A63001
Inlet Tube To Trans. (Upper).....	A61034			<b>1994-1992</b>			
Outlet Hose To Trans. (Lower).....	A61035			<b>V-6 3.1 L ENG.</b>			
Outlet Tube From Rad. (Lower); W/Aux. Cooler.....	B61037			Inlet Fitting To Trans. (Upper).....			A63006
Outlet Tube From Rad. (Lower); W/O Aux. Cooler.....	B61033			Inlet From Rad. (Upper).....			≈A63004
<b>1987-1986</b>				Inlet To Trans. (Upper).....	A61052		A63006
<b>V-6 3.8 L ENG.</b>				Outlet Fitting To Trans. (Lower).....			A63006
Inlet (Upper).....	A61044			Outlet From Rad. (Lower).....			≈A63004
Inlet Fitting To Trans. (Upper).....			A63006	Outlet To Trans. (Lower).....	A61052		≈A63004
Outlet (Lower).....	A61045			Rad. Supply Tube (Upper To Low- er).....			≈A63004
<b>REGENCY</b>				Tube Nut.....			●A63011
<b>1998</b>				<b>V-6 3.8 L ENG.</b>			
<b>V-6 3.8 L ENG.</b>				Inlet Fitting To Trans. (Upper).....			A63007
Inlet Fitting To Trans. (Upper).....				Inlet From Rad. (Lower); W/Aux. Cooler.....	B61054		
Inlet From Rad. (Upper).....	B61112		A63007	Inlet From Rad. (Upper); W/O Aux. Cooler.....	B61053		A63008
Outlet From Rad. (Lower).....	B61111			Outlet Fitting To Trans. (Lower).....			A63008
<b>1997</b>				Outlet From Rad. (Lower); W/Aux. Cooler.....			≈A63005
<b>V-6 3.8 L ENG.</b>				Outlet To Trans. (Upper); W/Aux. Cooler.....			≈A63001
Inlet Fitting To Trans. (Upper).....			A63007	<b>1991-1990</b>			
Inlet From Rad. (Upper); Feb. 18 & Older.....	B61241			<b>V-6 3.1 L ENG.</b>			
Inlet From Rad. (Upper); Feb. 19 & Newer.....	B61112		A63008	Inlet Fitting To Trans. (Upper).....			A63006
Outlet Fitting To Trans. (Lower).....				Inlet From Rad. (Upper).....			≈A63004
Outlet From Rad. (Lower); Feb. 18 & Older.....	B61009			Inlet To Trans. (Upper).....	A61052		A63006
Outlet From Rad. (Lower); Feb. 19 & Newer.....	B61111			Outlet Fitting To Trans. (Lower).....			≈A63004
<b>SILHOUETTE</b>				Outlet From Rad. (Lower).....	A61052		≈A63004
<b>2003-2000</b>				Rad. Supply Tube (Upper To Low- er).....			≈A63004
<b>V-6 3.4 L ENG.</b>				Tube Nut.....			●A63011
Connector From Rad. ....			②A63064	<b>TORONADO</b>			
Inlet Fitting To Trans. (Upper).....			A63021	<b>1992-1991</b>			
Outlet Fitting To Trans. (Lower).....			A63021	<b>V-6 3.8 L ENG.</b>			
Wire Retainer (Connectors & Fit- tings).....			●A63098	Aux. Cooler Outlet Hose (Upper) ...			≈A63001
<b>1999-1997</b>				Inlet Fitting To Trans. (Lower).....			A63087
<b>V-6 3.4 L ENG.</b>				Inlet From Rad. (Upper).....	B61137		A63007
Inlet Fitting To Trans. (Lower).....			A63007	Outlet Fitting To Trans. (Upper).....			A63008
<b>1996</b>				Outlet From Rad. (Lower).....	B61143		
<b>V-6 3.4 L ENG.</b>				Outlet To Trans. (Upper).....	A61140		
Inlet Fitting To Trans. (Upper).....			A63007	<b>1990-1988</b>			
Inlet From Rad. (Upper).....	B61053			<b>V-6 3.8 L ENG.</b>			
Outlet Fitting To Trans. (Lower).....			A63008	Aux. Cooler Inlet Hose (Lower).....			≈A63000
<b>1995</b>				Aux. Cooler Inlet Tube (Lower).....			≈A63004
<b>V-6 3.8 L ENG.</b>				Aux. Cooler Outlet Hose (Upper) ...			≈A63000
Inlet Fitting To Trans. (Upper).....			A63007	Aux. Cooler Outlet Tube (Upper) ...			≈A63004
Inlet From Rad. (Lower); W/Aux. Cooler.....	B61054			Inlet (Lower).....			≈A63000
Inlet From Rad. (Upper); W/O Aux. Cooler.....	B61053		A63008	Inlet Fitting To Trans. (Lower).....			②A63006
Outlet Fitting To Trans. (Lower).....			A63008	Outlet Hose (Upper).....			≈A63000
<b>1995</b>				Outlet Tube (Upper).....			≈A63004
<b>V-6 3.8 L ENG.</b>				Tube Nut.....			●A63011
Inlet Fitting To Trans. (Upper).....			A63007	<b>1987-1986</b>			
Inlet From Rad. (Lower); W/Aux. Cooler.....	B61054			<b>V-6 3.8 L ENG.</b>			
Inlet From Rad. (Upper); W/O Aux. Cooler.....	B61053		A63008	Inlet Fitting To Trans. (Lower).....			
Outlet Fitting To Trans. (Lower).....			A63008				

② Two Required.  
③ Three Required.

④ Four Required.  
⑤ Five Required.

⑥ Six Required.  
⑦ Seven Required.

≈ Cut To Fit.  
● As Required.

See Pages 1 - 10 for Engine Oil Cooler Applications.

## Transmission Oil Cooler Assemblies for Passenger Cars &amp; Light Trucks

Application	Assembly Number	Hoses & Tubes	Connectors & Fittings	Application	Assembly Number	Hoses & Tubes	Connectors & Fittings
<b>OLDSMOBILE - Continued</b>				<b>PLYMOUTH - Continued</b>			
<b>TORONADO - Continued</b>				<b>GRAND VOYAGER - Continued</b>			
<b>1987-1986 - Continued</b>				<b>1998 - Continued</b>			
<b>V-6 3.8 L ENG. - Continued</b>				<b>V-6 3.0 L ENG. - Continued</b>			
Inlet Hose (Lower).....		≡A63000		Outlet (Lower); W/4-Speed Trans.;			
Inlet Tube (Lower).....		≡A63004		W/O A.C. ....	A61008		
Outlet Hose (Lower).....		≡A63000		Outlet (Lower); W/4-Speed Trans.;			
Outlet Tube (Lower).....		≡A63004		W/Rear A.C. ....	A61095		
Tube Nut.....			●A63011	Rad. Oil Cooler Inlet (Lower);			
				W/3-Speed Trans. ....	B61065		
<b>PLYMOUTH</b>				Rad. Oil Cooler Supply (Upper);			
<b>ACCLAIM</b>				W/3-Speed Trans. ....			
<b>1990-1989</b>				B61066			
<b>4-CYL. 2.5 L ENG.; V-6 3.0 L ENG.</b>				<b>V-6 3.3 L ENG.; V-6 3.8 L ENG. (CANADA)</b>			
"O" Ring.....			ⓄA63093	Aux. Cooler Tube To Tube.....	A61007		
<b>BREEZE</b>				Inlet (Upper); W/Front A.C. ....			
<b>1997-1996</b>				A61102			
<b>4-CYL. 2.0 L ENG.</b>				Inlet (Upper); W/H.D. Rad. ....			
Inlet (Pass. Side).....	A61079			A61082			
Outlet (Driver Side).....	A61080			Inlet (Upper); W/Rear A.C. ....	A61074		
<b>CARAVELLE</b>				Outlet (Lower); W/Front A.C. ....			
<b>1988</b>				A61006			
<b>4-CYL. 2.2 L ENG.; 4-CYL. 2.5 L ENG.</b>				Outlet (Lower); W/H.D. Rad. ....			
"O" Ring From Aux. Cooler.....			ⓄA63093	A61082			
<b>1987-1986</b>				Outlet (Lower); W/Rear A.C. ....			
<b>4-CYL. 2.2 L ENG.; 4-CYL. 2.5 L ENG.</b>				A61008			
"O" Ring; W/Water Cooled Trans.				Rad. Oil Cooler Inlet (Lower).....	B61065		
Cooler.....			ⓄA63093	Rad. Oil Cooler Supply (Upper) ....	B61066		
<b>GRAN FURY</b>				<b>1997</b>			
<b>1989-1984</b>				<b>4-CYL. 2.4 L ENG.</b>			
<b>V-8 5.2 L ENG.</b>				Inlet (Upper); W/4-Speed Trans. ....			
Inlet.....		≡A63000		Outlet (Lower); W/4-Speed Trans....	A61008		
Inlet Fitting To Trans.....			A63042	<b>V-6 3.0 L ENG.</b>			
Outlet.....		≡A63000		Inlet (Upper); W/H.D. Rad. ....	A61096		
Outlet Fitting To Trans.....			A63042	Outlet (Lower); W/H.D. Rad. ....	A61095		
<b>GRAND VOYAGER</b>				<b>V-6 3.3 L ENG.; V-6 3.8 L ENG. (CANADA)</b>			
<b>2000</b>				Aux. Cooler Tube To Tube.....			
<b>V-6 3.0 L ENG.; V-6 3.3 L ENG.</b>				A61007			
Aux. Cooler Tube To Tube.....	A61007			Inlet (Upper); W/4-Speed Trans. ....	A61102		
Inlet (Upper).....	A61102			Inlet (Upper); W/H.D. Rad.; W/O			
Outlet (Lower); W/A.C. ....	A61006			Trlr. Tow. Pkg. ....	A61096		
Outlet (Lower); W/O A.C. ....	A61008			Inlet (Upper); W/Rear A.C. ....	A61074		
<b>1999</b>				Outlet (Lower); W/4-Speed Trans....			
<b>V-6 3.0 L ENG.; V-6 3.3 L ENG.; V-6 3.8 L ENG.</b>				A61006			
Aux. Cooler Tube To Tube.....	A61007			Outlet (Lower); W/H.D. Rad.; W/O			
Inlet (Upper).....	A61102			Trlr. Tow. Pkg. ....	A61095		
Outlet (Lower).....	A61006			Outlet (Lower); W/Rear A.C. ....	A61008		
<b>1998</b>				Rad. Oil Cooler Inlet (Lower);			
<b>V-6 3.0 L ENG.</b>				W/Trlr. Tow. Pkg. ....			
Inlet (Upper); W/4-Speed Trans.;				Rad. Oil Cooler Supply (Upper);			
W/Front A.C. ....	A61102			W/Trlr. Tow. Pkg. ....	B61066		
Inlet (Upper); W/4-Speed Trans.;				<b>1996</b>			
W/O A.C. ....	A61074			<b>4-CYL. 2.4 L ENG.</b>			
Inlet (Upper); W/4-Speed Trans.;				Inlet (Upper); W/3-Speed Trans. ....			
W/Rear A.C. ....	A61096			Outlet (Lower); W/3-Speed Trans....			
Outlet (Lower); W/4-Speed Trans.;				A61084			
W/Front A.C. ....	A61006			A61083			
				<b>V-6 3.3 L ENG.; V-6 3.8 L ENG.</b>			
				Rad. Oil Cooler Inlet (Lower);			
				W/Trlr. Tow. Pkg. ....			
				B61065			
				Rad. Oil Cooler Supply (Upper);			
				W/Trlr. Tow. Pkg. ....			
				B61066			
				<b>1995</b>			
				<b>V-6 3.0 L ENG.</b>			
				"O" Ring; W/Water Cooled Trans.			
				Cooler.....			
				ⓄA63093			
				Inlet (Upper); W/Water Cooled			
				Trans. Cooler; W/A.C. ....			
				A61093			
				Inlet (Upper); W/Water Cooled			
				Trans. Cooler; W/O A.C. ....			
				A61087			
				Inlet Hose; W/Air Cooled Trans.			
				Cooler.....			
				A61063			
				Outlet (Lower); W/Water Cooled			
				Trans. Cooler; W/A.C. ....			
				A61092			
				Outlet (Lower); W/Water Cooled			
				Trans. Cooler; W/O A.C. ....			
				A61085			
				Outlet Tube; W/Air Cooled Trans.			
				Cooler.....			
				B61064			

② Two Required.  
③ Three Required.

④ Four Required.  
⑤ Five Required.

⑥ Six Required.  
⑦ Seven Required.

≡ Cut To Fit.  
● As Required.

See Pages 1 - 10 for Engine Oil Cooler Applications.



## Transmission Oil Cooler Assemblies for Passenger Cars & Light Trucks

Application	Assembly Number	Hoses & Tubes	Connectors & Fittings	Application	Assembly Number	Hoses & Tubes	Connectors & Fittings
<b>PLYMOUTH - Continued</b>				<b>PLYMOUTH - Continued</b>			
<b>GRAND VOYAGER - Continued</b>				<b>GRAND VOYAGER - Continued</b>			
<b>1995 - Continued</b>				<b>1993 - Continued</b>			
<b>V-6 3.3 L ENG.; V-6 3.8 L ENG.</b>				<b>V-6 3.0 L ENG. - Continued</b>			
"O" Ring; W/Water Cooled Trans. Cooler.....			②A63093	Inlet (Upper); W/Water Cooled Trans. Cooler; W/Rear A.C. ....	A61087		
Inlet (Upper); W/Water Cooled Trans. Cooler; W/A.C.....	A61094			Inlet Hose; W/Air Cooled Trans. Cooler.....	A61063		
Inlet (Upper); W/Water Cooled Trans. Cooler; W/O A.C. ....	A61091			Outlet (Lower); W/Water Cooled Trans. Cooler.....	A61085		
Inlet Hose; W/Air Cooled Trans. Cooler.....	A61063			Outlet Tube; W/Air Cooled Trans. Cooler.....	B61064		
Outlet (Lower); W/Water Cooled Trans. Cooler; W/A.C.....	A61092			<b>V-6 3.3 L ENG.</b>			
Outlet (Lower); W/Water Cooled Trans. Cooler; W/O A.C. ....	A61090			"O" Ring; W/Water Cooled Trans. Cooler.....			②A63093
Outlet Tube; W/Air Cooled Trans. Cooler.....	B61064			Inlet (Upper); W/Water Cooled Trans. Cooler.....	A61091		
<b>1994</b>				Inlet Hose; W/Air Cooled Trans. Cooler.....	A61063		
<b>V-6 3.0 L ENG.</b>				Outlet (Lower); W/Water Cooled Trans. Cooler.....	A61090		
"O" Ring; W/Water Cooled Trans. Cooler.....			②A63093	Outlet Tube; W/Air Cooled Trans. Cooler.....	B61064		
Inlet (Upper); W/Water Cooled Trans. Cooler; W/3-Speed Trans.; W/O Rear A.C. ....	A61062			<b>1992</b>			
Inlet (Upper); W/Water Cooled Trans. Cooler; W/3-Speed Trans.; W/Rear A.C. ....	A61089			<b>V-6 3.0 L ENG.</b>			
Inlet (Upper); W/Water Cooled Trans. Cooler; W/4-Speed Trans.; W/A.C.....	A61093			"O" Ring; W/Water Cooled Trans. Cooler.....			②A63093
Inlet (Upper); W/Water Cooled Trans. Cooler; W/4-Speed Trans.; W/O A.C. ....	A61087			<b>V-6 3.3 L ENG.</b>			
Inlet Hose; W/Air Cooled Trans. Cooler.....	A61063			"O" Ring; W/Water Cooled Trans. Cooler.....			②A63093
Outlet (Lower); W/Water Cooled Trans. Cooler; W/3-Speed Trans.; W/O Rear A.C. ....	A61061			Inlet Hose; W/Air Cooled Trans. Cooler; W/AWD.....		⊗A63000	
Outlet (Lower); W/Water Cooled Trans. Cooler; W/3-Speed Trans.; W/Rear A.C. ....	A61088			Outlet Hose; W/Air Cooled Trans. Cooler; W/AWD.....		⊗A63000	
Outlet (Lower); W/Water Cooled Trans. Cooler; W/4-Speed Trans.; W/A.C.....	A61092			<b>1991</b>			
Outlet (Lower); W/Water Cooled Trans. Cooler; W/4-Speed Trans.; W/O A.C. ....	A61085			<b>V-6 3.3 L ENG.</b>			
Outlet Tube; W/Air Cooled Trans. Cooler.....	B61064			"O" Ring; W/Water Cooled Trans. Cooler.....			②A63093
<b>V-6 3.3 L ENG.; V-6 3.8 L ENG.</b>				Inlet Hose; W/Air Cooled Trans. Cooler.....		⊗A63000	
"O" Ring; W/Water Cooled Trans. Cooler.....			②A63093	Outlet (Lower); W/Water Cooled Trans. Cooler.....		⊗A63000	
Inlet (Upper); W/Water Cooled Trans. Cooler; W/A.C.....	A61094			<b>1990</b>			
Inlet (Upper); W/Water Cooled Trans. Cooler; W/O A.C. ....	A61091			<b>V-6 3.3 L ENG.</b>			
Inlet Hose; W/Air Cooled Trans. Cooler.....	A61063			"O" Ring; W/Water Cooled Trans. Cooler.....			②A63093
Outlet (Lower); W/Water Cooled Trans. Cooler; W/A.C.....	A61092			Inlet Hose.....		⊗A63000	
Outlet (Lower); W/Water Cooled Trans. Cooler; W/4-Speed Trans.; W/O A.C. ....	A61090			Outlet Hose.....		⊗A63000	
Outlet Tube; W/Air Cooled Trans. Cooler.....	B61064			<b>1989</b>			
<b>1993</b>				<b>4-CYL. 2.5 L ENG.; V-6 3.0 L ENG.</b>			
<b>V-6 3.0 L ENG.</b>				"O" Ring; W/Water Cooled Trans. Cooler.....			②A63093
"O" Ring; W/Water Cooled Trans. Cooler.....			②A63093	<b>1988</b>			
Inlet (Upper); W/Water Cooled Trans. Cooler; W/A.C.....	A61094			<b>4-CYL. 2.5 L ENG.</b>			
Inlet (Upper); W/Water Cooled Trans. Cooler; W/O A.C. ....	A61091			"O" Ring; W/Water Cooled Trans. Cooler.....			②A63093
Inlet Hose; W/Air Cooled Trans. Cooler.....	A61063			<b>HORIZON</b>			
Outlet (Lower); W/Water Cooled Trans. Cooler; W/A.C.....	A61092			<b>1990</b>			
Outlet (Lower); W/Water Cooled Trans. Cooler; W/O A.C. ....	A61090			<b>4-CYL. 2.2 L ENG.</b>			
Outlet Tube; W/Air Cooled Trans. Cooler.....	B61064			"O" Ring; W/Water Cooled Trans. Cooler.....			②A63093

② Two Required.  
③ Three Required.

④ Four Required.  
⑤ Five Required.

⑥ Six Required.  
⑦ Seven Required.

⊗ Cut To Fit.  
● As Required.

See Pages 1 - 10 for Engine Oil Cooler Applications.



## Transmission Oil Cooler Assemblies for Passenger Cars & Light Trucks

Application	Assembly Number	Hoses & Tubes	Connectors & Fittings	Application	Assembly Number	Hoses & Tubes	Connectors & Fittings
<b>PLYMOUTH - Continued</b>				<b>PLYMOUTH - Continued</b>			
<b>VOYAGER - Continued</b>				<b>VOYAGER - Continued</b>			
<b>1996 - Continued</b>				<b>1993 - Continued</b>			
<b>V-6 3.3 L ENG.; V-6 3.8 L ENG.</b>				<b>4-CYL. 2.5 L ENG. - Continued</b>			
Rad. Oil Cooler Inlet (Lower); W/Trlr. Tow. Pkg. ....	<b>B61065</b>			Inlet (Upper); W/Water Cooled Trans. Cooler .....	<b>A61061</b>		
Rad. Oil Cooler Supply (Upper); W/Trlr. Tow. Pkg. ....	<b>B61066</b>			Inlet Hose; W/Air Cooled Trans. Cooler .....	<b>A61063</b>		
<b>1995-1994</b>				Outlet (Lower); W/Water Cooled Trans. Cooler .....			
<b>4-CYL. 2.5 L ENG.</b>				Outlet Tube; W/Air Cooled Trans. Cooler .....			
"O" Ring; W/Water Cooled Trans. Cooler .....			② <b>A63093</b>	<b>V-6 3.0 L ENG.</b>			
Inlet (Upper); W/Water Cooled Trans. Cooler .....	<b>A61061</b>			"O" Ring; W/Water Cooled Trans. Cooler .....			② <b>A63093</b>
Inlet Hose; W/Air Cooled Trans. Cooler .....	<b>A61063</b>			Inlet (Upper); W/Water Cooled Trans. Cooler; W/O Rear A.C. ....	<b>A61086</b>		
Outlet (Lower); W/Water Cooled Trans. Cooler .....	<b>A61062</b>			Inlet (Upper); W/Water Cooled Trans. Cooler; W/Rear A.C. ....	<b>A61087</b>		
Outlet Tube; W/Air Cooled Trans. Cooler .....	<b>B61064</b>			Inlet Hose; W/Air Cooled Trans. Cooler .....	<b>A61063</b>		
<b>V-6 3.0 L ENG.</b>				Outlet (Lower); W/Water Cooled Trans. Cooler .....			
"O" Ring; W/Water Cooled Trans. Cooler .....			② <b>A63093</b>	Outlet Tube; W/Air Cooled Trans. Cooler .....			
Inlet (Upper); W/Water Cooled Trans. Cooler; W/3-Speed Trans.; W/O Rear A.C. ....	<b>A61062</b>			<b>V-6 3.3 L ENG.</b>			
Inlet (Upper); W/Water Cooled Trans. Cooler; W/3-Speed Trans.; W/Rear A.C. ....	<b>A61089</b>			"O" Ring; W/Water Cooled Trans. Cooler .....			② <b>A63093</b>
Inlet (Upper); W/Water Cooled Trans. Cooler; W/4-Speed Trans.; W/A.C. ....	<b>A61093</b>			Inlet (Upper); W/Water Cooled Trans. Cooler .....	<b>A61091</b>		
Inlet (Upper); W/Water Cooled Trans. Cooler; W/4-Speed Trans.; W/O A.C. ....	<b>A61087</b>			Inlet Hose; W/Air Cooled Trans. Cooler .....	<b>A61063</b>		
Inlet Hose; W/Air Cooled Trans. Cooler .....	<b>A61063</b>			Outlet (Lower); W/Water Cooled Trans. Cooler .....	<b>A61090</b>		
Outlet (Lower); W/Water Cooled Trans. Cooler; W/3-Speed Trans.; W/O Rear A.C. ....	<b>A61061</b>			Outlet Tube; W/Air Cooled Trans. Cooler .....	<b>B61064</b>		
Outlet (Lower); W/Water Cooled Trans. Cooler; W/3-Speed Trans.; W/Rear A.C. ....	<b>A61088</b>			<b>1992</b>			
Outlet (Lower); W/Water Cooled Trans. Cooler; W/4-Speed Trans.; W/A.C. ....	<b>A61092</b>			<b>4-CYL. 2.5 L ENG.; V-6 3.0 L ENG.</b>			
Outlet (Lower); W/Water Cooled Trans. Cooler; W/4-Speed Trans.; W/O A.C. ....	<b>A61085</b>			"O" Ring; W/Water Cooled Trans. Cooler .....			② <b>A63093</b>
Outlet Tube; W/Air Cooled Trans. Cooler .....	<b>B61064</b>			<b>V-6 3.3 L ENG.</b>			
<b>V-6 3.3 L ENG.</b>				"O" Ring; W/Water Cooled Trans. Cooler .....			
"O" Ring; W/Water Cooled Trans. Cooler .....			② <b>A63093</b>	Inlet Hose; W/Air Cooled Trans. Cooler; W/AWD .....			
Inlet (Upper); W/Water Cooled Trans. Cooler; W/3-Speed Trans.; W/O Rear A.C. ....	<b>A61094</b>			Outlet Hose; W/Air Cooled Trans. Cooler; W/AWD .....			
Inlet (Upper); W/Water Cooled Trans. Cooler; W/O A.C. ....	<b>A61091</b>			<b>1991</b>			
Inlet Hose; W/Air Cooled Trans. Cooler .....	<b>A61063</b>			<b>4-CYL. 2.5 L ENG.; V-6 3.3 L ENG.</b>			
Outlet (Lower); W/Water Cooled Trans. Cooler; W/A.C. ....	<b>A61092</b>			"O" Ring; W/Water Cooled Trans. Cooler .....			② <b>A63093</b>
Outlet (Lower); W/Water Cooled Trans. Cooler; W/O A.C. ....	<b>A61090</b>			Inlet Hose; W/Air Cooled Trans. Cooler .....	≠ <b>A63000</b>		
Outlet Tube; W/Air Cooled Trans. Cooler .....	<b>B61064</b>			Outlet (Lower); W/Water Cooled Trans. Cooler .....	≠ <b>A63000</b>		
<b>1993</b>				<b>V-6 3.0 L ENG.</b>			
<b>4-CYL. 2.5 L ENG.</b>				"O" Ring; W/Water Cooled Trans. Cooler .....			
"O" Ring; W/Water Cooled Trans. Cooler .....			② <b>A63093</b>	Inlet Hose; W/Air Cooled Trans. Cooler .....			
<b>1993</b>				<b>4-CYL. 2.5 L ENG.</b>			
<b>4-CYL. 2.5 L ENG.</b>				"O" Ring; W/Water Cooled Trans. Cooler .....			
"O" Ring; W/Water Cooled Trans. Cooler .....			② <b>A63093</b>	Inlet Hose; W/Air Cooled Trans. Cooler .....			

② Two Required.  
③ Three Required.

④ Four Required.  
⑤ Five Required.

⑥ Six Required.  
⑦ Seven Required.

≠ Cut To Fit.  
● As Required.

See Pages 1 - 10 for Engine Oil Cooler Applications.

## Transmission Oil Cooler Assemblies for Passenger Cars &amp; Light Trucks

Application	Assembly Number	Hoses & Tubes	Connectors & Fittings	Application	Assembly Number	Hoses & Tubes	Connectors & Fittings
<b>PLYMOUTH - Continued</b>				<b>PONTIAC - Continued</b>			
<b>VOYAGER - Continued</b>				<b>BONNEVILLE - Continued</b>			
<b>1990 - Continued</b>				<b>1996</b>			
<b>V-6 3.0 L ENG.</b>				<b>V-6 3.8 L ENG.</b>			
"O" Ring; W/Water Cooled Trans.				Aux. Cooler Outlet Tube (Upper) ....	A61271		
Cooler.....			⊙A63093	Inlet (Upper); W/O Aux. Cooler .....	B61241		
Inlet Hose; W/Air Cooled Trans.				Inlet Fitting To Trans. (Upper) .....			A63007
Cooler.....	≠A63000			Outlet (Lower).....	B61009		
Outlet Hose; W/Air Cooled Trans.				Outlet Fitting To Trans. (Lower) .....			A63008
Cooler.....	≠A63000			Outlet From Rad. (Lower).....	B61009		
<b>PONTIAC</b>				<b>1995-1994</b>			
<b>AZTEK</b>				<b>V-6 3.8 L ENG.</b>			
<b>2003-2001</b>				<b>V-6 3.8 L ENG.</b>			
V-6 3.4 L ENG.				Aux. Cooler Outlet Tube (Upper) ....	A61271		
Inlet Fitting To Trans. (Upper).....			A63021	Inlet Fitting To Trans. (Upper) .....			A63007
Outlet Fitting To Trans. (Lower) .....			A63064	Inlet From Rad. (Upper); W/Aux.			
Wire Retainer (Connectors & Fit- tings).....			●A63098	Cooler.....	B61110		
<b>BONNEVILLE</b>				Inlet From Rad. (Upper); W/O Aux.			
<b>2005-2004</b>				Cooler.....			
V-6 3.8 L ENG.				Outlet Fitting To Trans. (Lower) .....	B61112		A63008
Connector From Rad. ....			⊙A63018	Outlet From Rad. (Lower).....	B61111		
Inlet (Upper) .....	B61293			<b>1993</b>			
Outlet (Lower).....	B61292			<b>V-6 3.8 L ENG.</b>			
Wire Retainer (Connectors & Fit- tings).....			⊙A63098	Aux. Cooler Outlet Tube (Upper) ....	A61271		
<b>2003-2002</b>				Inlet Fitting To Trans. (Lower) .....			
V-6 3.8 L ENG.				Inlet From Rad. (Upper); W/Aux.			A63007
Connector From Rad. ....			⊙A63018	Cooler.....	B61110		
Inlet (Upper) .....	B61293			Inlet From Rad. (Upper); W/O Aux.			
Inlet Fitting To Trans. (Upper) .....			A63021	Cooler.....	B61112		
Outlet (Lower).....	B61292			Inlet To Trans. (Lower); W/O Aux.			
Outlet Fitting To Trans. (Lower) .....			A63064	Cooler.....	A61274		
Wire Retainer (Connectors & Fit- tings).....			⊙A63098	Outlet Fitting To Trans. (Upper) .....			A63008
<b>2001-2000</b>				Outlet From Rad. (Lower).....			
V-6 3.8 L ENG.				Outlet To Trans. (Upper) .....	B61244		
Connector From Rad. ....			⊙A63018		A61243		
Inlet (Upper) .....	B61293			<b>1992-1991</b>			
Inlet Fitting To Trans. (Upper) .....			A63021	<b>V-6 3.8 L ENG.</b>			
Outlet (Lower).....	B61292			Aux. Cooler Outlet Tube (Upper) ....	A61271		
Outlet Fitting To Trans. (Lower) .....			A63064	Inlet Fitting To Trans. (Lower) .....			A63007
Wire Retainer (Connectors & Fit- tings).....			⊙A63098	Inlet From Rad. (Upper); W/O Aux.			
<b>2001-2000</b>				Cooler.....			
V-6 3.8 L ENG.				Inlet To Trans. (Lower); W/Aux.			
Connector From Rad. ....			⊙A63018	Cooler.....	B61245		
Inlet Fitting To Trans. (Upper).....			A63021	Inlet To Trans. (Lower); W/O Aux.			
Outlet Fitting To Trans. (Lower) .....			A63064	Cooler.....	A61274		
Wire Retainer (Connectors & Fit- tings).....			⊙A63098	Outlet Fitting To Trans. (Upper) .....			A63008
<b>1999-1998</b>				Outlet From Rad. (Lower).....			
V-6 3.8 L ENG.				Outlet To Trans. (Upper) .....	B61244		
Inlet Fitting To Trans. (Upper).....			A63007		A61243		
Inlet From Rad. (Upper).....	B61112			<b>1990-1988</b>			
Outlet From Rad. (Lower).....	B61111			<b>V-6 3.8 L ENG.</b>			
<b>1997</b>				Inlet Fitting To Trans. (Upper).....			
V-6 3.8 L ENG.				Inlet Hose From Rad. (Upper);			
Inlet Fitting To Trans. (Upper).....			A63007	W/Aux. Cooler.....	B61036		
Inlet From Rad. (Upper); Feb. 18 & Older.....	B61241			Inlet Tube From Rad. (Upper);			
Inlet From Rad. (Upper); Feb. 19 & Newer.....	B61112			W/O Aux. Cooler.....	B61032		
Outlet Fitting To Trans. (Lower) .....			A63008	Inlet Tube To Trans. (Upper).....	A61034		
Outlet From Rad. (Lower); Feb. 18 & Older.....	B61009			Outlet Hose To Trans. (Lower).....	A61035		
Outlet From Rad. (Lower); Feb. 19 & Newer.....	B61111			Outlet Tube From Rad. (Lower);			
<b>1999-1998</b>				W/Aux. Cooler.....			
V-6 3.8 L ENG.				Outlet Tube From Rad. (Lower);	B61037		
Inlet Fitting To Trans. (Upper).....			A63007	W/O Aux. Cooler.....	B61033		
Inlet From Rad. (Upper); Feb. 18 & Older.....	B61241			<b>1987</b>			
Inlet From Rad. (Upper); Feb. 19 & Newer.....	B61112			<b>V-6 3.8 L ENG.</b>			
Outlet Fitting To Trans. (Lower) .....			A63008	Inlet (Upper) .....	A61044		
Outlet From Rad. (Lower); Feb. 18 & Older.....	B61009			Inlet Fitting To Trans. (Upper) .....			A63006
Outlet From Rad. (Lower); Feb. 19 & Newer.....	B61111			Outlet (Lower).....	A61045		

⊙ Two Required.  
⊚ Three Required.

⊛ Four Required.  
⊜ Five Required.

⊝ Six Required.  
⊞ Seven Required.

≠ Cut To Fit.  
● As Required.

See Pages 1 - 10 for Engine Oil Cooler Applications.

# Transmission Oil Cooler Assemblies for Passenger Cars & Light Trucks

Application	Assembly Number	Hoses & Tubes	Connectors & Fittings	Application	Assembly Number	Hoses & Tubes	Connectors & Fittings
<b>PONTIAC - Continued</b>				<b>PONTIAC - Continued</b>			
<b>BONNEVILLE - Continued</b>				<b>FIREBIRD - Continued</b>			
<b>1986</b>				<b>1989-1988</b>			
<b>V-6 3.8 L ENG.</b>				<b>V-6 2.8 L ENG.; V-8 5.0 L ENG.; V-8 5.7 L ENG.</b>			
Inlet (Upper) .....	A61044			Inlet (Upper) .....		⊗A63004	
Inlet Fitting To Trans. (Upper) .....			A63006	Inlet Fitting To Trans. (Upper) .....			A63006
Outlet (Lower) .....	A61045			Outlet (Lower) .....		⊗A63004	
Outlet Fitting To Trans. (Lower); W/3-Speed Trans. ....			A63006	Outlet Fitting To Trans. (Lower) .....			A63006
				Tube Nut .....			④A63011
<b>FIREBIRD</b>				<b>GRAND AM</b>			
<b>2002-1998</b>				<b>1998-1996</b>			
<b>V-6 3.8 L ENG.</b>				<b>4-CYL. 2.4 L ENG.; V-6 3.1 L ENG.</b>			
Inlet Fitting To Trans. (Upper) .....			A63021	Inlet (Upper) .....	B61119		
Inlet From Rad. (Upper) .....	A61221			Inlet Fitting To Trans. (Upper) .....			A63007
Inlet To Trans. (Lower) .....	B61297			Outlet (Lower) .....	A61134		
Outlet Fitting To Trans. (Lower) .....			A63021	Outlet Fitting To Trans. (Lower); W/Check Ball .....			A63008
Outlet From Rad. (Lower) .....	B61296			Outlet Fitting To Trans. (Lower); W/O Check Ball .....			A63007
Wire Retainer (Fittings) .....			②A63098				
<b>V-8 5.7 L ENG.</b>				<b>1995-1994</b>			
Inlet Fitting To Trans. (Upper) .....			A63021	<b>4-CYL. 2.3 L ENG.</b>			
Inlet From Rad. (Upper) .....	A61221			Inlet (Upper); W/3-Speed Trans. ....	B61232		
Inlet To Trans. (Lower) .....	B61295			Inlet (Upper); W/4-Speed Trans. ....	B61119		
Outlet Fitting To Trans. (Lower) .....			A63021	Inlet Fitting To Trans. (Upper); W/3-Speed Trans. ....			A63006
Outlet From Rad. (Lower) .....	B61294			Inlet Fitting To Trans. (Upper); W/4-Speed Trans. ....			A63007
Wire Retainer (Fittings) .....			②A63098	Outlet (Lower); W/3-Speed Trans. ....	B61233		
<b>1997-1996</b>				<b>V-6 3.1 L ENG.</b>			
<b>V-6 3.8 L ENG.; V-8 5.7 L ENG.</b>				Inlet (Upper) .....			
Inlet Fitting To Trans. (Upper) .....			A63006	Inlet (Upper) .....	B61119		
Inlet From Rad. (Upper) .....	A61221			Inlet Fitting To Trans. (Upper) .....			A63007
Inlet Tube To Trans. (Upper) .....		⊗A63004		Outlet (Lower) .....	A61134		
Outlet Fitting To Trans. (Lower) .....			A63006	Outlet Fitting To Trans. (Lower); W/3-Speed Trans. ....			A63006
Outlet Hose From Rad. (Lower) .....		⊗A63000		Outlet Fitting To Trans. (Lower); W/4-Speed Trans. ....			A63008
Outlet Tube From Rad. (Lower) .....		⊗A63004		Outlet Fitting To Trans. (Lower); W/4-Speed Trans. ....			A63008
Outlet Tube To Trans. (Lower) .....		⊗A63004					
Tube Nut .....			●A63011				
<b>1995</b>				<b>1993-1992</b>			
<b>V-6 3.4 L ENG.; V-6 3.8 L ENG.; V-8 5.7 L ENG.</b>				<b>4-CYL. 2.3 L ENG.; V-6 3.3 L ENG.</b>			
Inlet Fitting To Trans. (Upper) .....			A63006	Inlet (Upper) .....	A61228		
Inlet From Rad. (Upper) .....	A61221			Inlet Fitting To Trans. (Upper) .....			A63006
Inlet Tube To Trans. (Upper) .....		⊗A63004		Outlet (Lower) .....	A61227		
Outlet Fitting To Trans. (Lower) .....			A63006	Outlet Fitting To Trans. (Lower) .....			A63006
Outlet Hose From Rad. (Lower) .....		⊗A63000					
Outlet Tube From Rad. (Lower) .....		⊗A63004		<b>1991-1990</b>			
Outlet Tube To Trans. (Lower) .....		⊗A63004		<b>4-CYL. 2.3 L ENG.</b>			
Tube Nut .....			●A63011	Inlet (Upper) .....	A61225		
<b>1994-1993</b>				Inlet Fitting To Trans. (Upper) .....			
<b>V-6 3.4 L ENG.; V-8 5.7 L ENG.</b>				Inlet Fitting To Trans. (Upper) .....			
Inlet Fitting To Trans. (Upper) .....			A63006	Outlet (Lower) .....	A61226		A63006
Inlet From Rad. (Upper) .....	A61221			Outlet Fitting To Trans. (Lower) .....			A63006
Inlet Tube To Trans. (Upper) .....		⊗A63004					
Outlet Fitting To Trans. (Lower) .....			A63006	<b>4-CYL. 2.5 L ENG.</b>			
Outlet Hose From Rad. (Lower) .....		⊗A63000		Inlet (Upper) .....	A61224		A63006
Outlet Tube From Rad. (Lower) .....		⊗A63004		Inlet Fitting To Trans. (Upper) .....			A63006
Outlet Tube To Trans. (Lower) .....		⊗A63004		Outlet (Lower) .....	A61248		A63006
Tube Nut .....			●A63011	Outlet Fitting To Trans. (Lower) .....			A63006
<b>1992-1990</b>				<b>1989-1988</b>			
<b>V-6 3.1 L ENG.; V-8 5.0 L ENG.; V-8 5.7 L ENG.</b>				<b>4-CYL. 2.0 L ENG.; 4-CYL. 2.3 L ENG.</b>			
Inlet (Upper) .....		⊗A63004		Inlet (Upper) .....	A61223		
Inlet Fitting To Trans. (Upper) .....			A63006	Inlet Fitting To Trans. (Upper) .....			A63006
Outlet (Lower) .....		⊗A63004		Outlet (Lower) .....	A61222		A63006
Outlet Fitting To Trans. (Lower) .....			A63006	Outlet Fitting To Trans. (Lower) .....			A63006
Tube Nut .....			④A63011	<b>4-CYL. 2.5 L ENG.</b>			
				Inlet (Upper) .....	A61223		A63006
				Inlet Fitting To Trans. (Upper) .....			A63006
				Outlet (Lower) .....	A61248		A63006
				Outlet Fitting To Trans. (Lower) .....			A63006

② Two Required.  
③ Three Required.

④ Four Required.  
⑤ Five Required.

⑥ Six Required.  
⑦ Seven Required.

⊗ Cut To Fit.  
● As Required.

See Pages 1 - 10 for Engine Oil Cooler Applications.

Product Section

Troubleshooting

EOC Applications

TOC Applications

Numerical Listing

Manufacturers' Part Numbers

End Fittings

Illustrations

## Transmission Oil Cooler Assemblies for Passenger Cars &amp; Light Trucks

Application	Assembly Number	Hoses & Tubes	Connectors & Fittings	Application	Assembly Number	Hoses & Tubes	Connectors & Fittings
<b>PONTIAC - Continued</b>				<b>PONTIAC - Continued</b>			
<b>GRAND AM - Continued</b>				<b>GRAND PRIX - Continued</b>			
<b>1989-1988 - Continued</b>				<b>1993-1992 - Continued</b>			
<b>4-CYL. 2.5 L ENG. - Continued</b>				<b>V-6 3.1 L ENG. - Continued</b>			
Outlet Fitting To Trans. (Lower) .....			A63006	Tube Nut; W/3-Speed Trans.....			④ A63011
				Tube Nut; W/4-Speed Trans.....			⑦ A63013
<b>GRAND PRIX</b>				<b>V-6 3.4 L ENG.</b>			
<b>2003-2000</b>				Inlet Fitting To Trans. (Upper).....			
<b>V-6 3.1 L ENG.; V-6 3.8 L ENG.</b>				Inlet To Trans. (Upper).....			
Connector From Rad. ....			② A63065	A61031		⑤ A63005	A63007
Inlet Fitting To Trans. (Upper).....			A63021	Inlet Tube From Rad. (Upper).....			A63008
Outlet Fitting To Trans. (Lower).....			A63064	Outlet Fitting To Trans. (Lower).....	A61030		A63008
Wire Retainer (Connectors & Fittings).....			● A63098	Outlet To Trans. (Lower).....		⑤ A63005	② A63013
				Tube Nut.....			
<b>1999-1998</b>				<b>1991</b>			
<b>V-6 3.1 L ENG.; V-6 3.8 L ENG.</b>				<b>4-CYL. 2.3 L ENG.</b>			
Aux. Cooler Inlet (Upper).....	B61237			Aux. Cooler Inlet Tube (Upper).....		⑤ A63004	
Aux. Cooler Outlet (Lower).....	A61236			Aux. Cooler Outlet Tube (Lower) ...		⑤ A63004	
Connector From Rad.; W/Aux. Cooler .....			② A63018	Inlet Fitting To Trans. (Upper).....			A63006
Inlet (Upper); W/O Aux. Cooler .....	B61239			Inlet Hose (Upper).....		⑤ A63000	
Inlet Fitting To Trans. (Upper).....			A63007	Inlet Tube To Trans. (Upper).....		⑤ A63004	A63006
Inlet To Trans. (Upper); W/Aux. Cooler .....				Outlet Fitting To Trans. (Lower).....		⑤ A63000	
Outlet (Lower); W/O Aux. Cooler ...	B61238			Outlet Hose (Lower).....		⑤ A63004	
Outlet Fitting To Trans. (Lower).....			A63008	Outlet Tube To Trans. (Lower).....			● A63011
Outlet To Trans. (Lower); W/Aux. Cooler .....				Tube Nut.....			
Wire Retainer (Connectors & Fittings).....			● A63098	<b>V-6 3.1 L ENG.; V-6 3.4 L ENG.</b>			
				Inlet Fitting To Trans. (Upper);			A63006
				W/3-Speed Trans.....			A63007
				Inlet Fitting To Trans. (Upper);			A63007
				W/4-Speed Trans.....			
				Inlet Hose (Upper); W/3-Speed Trans. ....		⑤ A63000	
				Inlet To Trans. (Upper); W/4-Speed Trans. ....	A61031		
				Inlet Tube From Rad. (Upper);			
				W/4-Speed Trans.....		⑤ A63005	
				Inlet Tube To Trans. (Upper);			
				W/3-Speed Trans.....		⑤ A63004	
				Outlet Fitting To Trans. (Lower);			A63006
				W/3-Speed Trans.....			A63008
				Outlet Fitting To Trans. (Lower);			
				W/4-Speed Trans.....			
				Outlet Hose (Lower); W/3-Speed Trans. ....		⑤ A63000	
				Outlet To Trans. (Lower);			
				W/4-Speed Trans.....	A61030		
				Outlet Tube To Trans. (Lower);			
				W/3-Speed Trans.....		⑤ A63004	
				Tube Nut; W/3-Speed Trans.....			④ A63011
				Tube Nut; W/4-Speed Trans.....			⑦ A63013
				<b>1990</b>			
				<b>4-CYL. 2.3 L ENG.</b>			
				Aux. Cooler Inlet Tube (Upper).....		⑤ A63004	
				Aux. Cooler Outlet Tube (Lower) ...		⑤ A63004	
				Inlet Fitting To Trans. (Upper).....			A63006
				Inlet Hose (Upper).....		⑤ A63000	
				Inlet Tube To Trans. (Upper).....		⑤ A63004	A63006
				Outlet Fitting To Trans. (Lower).....			A63006
				Outlet Hose (Lower).....		⑤ A63000	
				Outlet Tube To Trans. (Lower).....		⑤ A63004	
				Tube Nut.....			● A63011
				<b>V-6 3.1 L ENG.</b>			
				Inlet Fitting To Trans. (Upper);			A63008
				W/Check Ball.....			
				Inlet Fitting To Trans. (Upper);			● A63006
				W/O Turbo.....			
				Inlet Fitting To Trans. Case (Upper);			A63007
				W/Turbo.....			
				Inlet Hose To Trans. (Upper);			
				W/Turbo.....		⑤ A63000	
				Inlet Tube From Rad. (Upper).....		⑤ A63004	

② Two Required.  
③ Three Required.

④ Four Required.  
⑤ Five Required.

⑥ Six Required.  
⑦ Seven Required.

✕ Cut To Fit.  
● As Required.

See Pages 1 - 10 for Engine Oil Cooler Applications.

## Transmission Oil Cooler Assemblies for Passenger Cars & Light Trucks

Application	Assembly Number	Hoses & Tubes	Connectors & Fittings	Application	Assembly Number	Hoses & Tubes	Connectors & Fittings
<b>PONTIAC - Continued</b>				<b>PONTIAC - Continued</b>			
<b>GRAND PRIX - Continued</b>				<b>LEMANS - Continued</b>			
<b>1990 - Continued</b>				<b>1988 - Continued</b>			
<b>V-6 3.1 L ENG. - Continued</b>				<b>4-CYL. 1.6 L ENG. - Continued</b>			
Inlet Tube To Trans. (Upper); W/Turbo.....		∅-A63004	●A63006	Banjo Washers.....			●A63101
Outlet Fitting To Trans. (Lower).....				Inlet Hose.....	∅-A63001		
Outlet Hose To Trans. (Lower); W/O Turbo.....		∅-A63000		Outlet Hose.....	∅-A63001		
Outlet Tube From Rad. (Lower).....		∅-A63004		<b>MONTANA</b>			
Outlet Tube To Trans. (Lower); W/O Turbo.....		∅-A63004		<b>2003-2001</b>			
Tube Nut.....			●A63011	<b>V-6 3.4 L ENG.</b>			
<b>1989</b>				Inlet Fitting To Trans. (Upper).....			
<b>V-6 2.8 L ENG.</b>				Outlet Fitting To Trans. (Lower).....			
Inlet Fitting To Trans. (Upper).....		∅-A63004	●A63006	Wire Retainer (Connectors & Fittings).....			
Inlet Tube From Rad. (Upper).....							
Outlet Fitting To Trans. (Lower).....		∅-A63000	●A63006	<b>2000</b>			
Outlet Hose To Trans. (Lower).....		∅-A63004		<b>V-6 3.4 L ENG.</b>			
Outlet Tube From Rad. (Lower).....		∅-A63004		Connector From Rad. ....			
Outlet Tube To Trans. (Lower).....		∅-A63004		Inlet Fitting To Trans. (Upper).....			
Tube Nut.....			●A63011	Outlet Fitting To Trans. (Lower).....			
<b>V-6 3.1 L ENG.</b>				Wire Retainer (Connectors & Fittings).....			
Inlet Fitting To Trans. (Upper); W/Check Ball.....			A63008				
Inlet Fitting To Trans. (Upper); W/O Turbo.....			●A63006	<b>1999</b>			
Inlet Fitting To Trans. Case (Upper); W/Turbo.....			A63007	<b>V-6 3.4 L ENG.</b>			
Inlet Hose To Trans. (Upper); W/Turbo.....		∅-A63000		Inlet Fitting To Trans. (Lower).....			
Inlet Tube From Rad. (Upper).....		∅-A63004					
Inlet Tube To Trans. (Upper); W/Turbo.....		∅-A63004		<b>SUNBIRD</b>			
Outlet Fitting To Trans. (Lower).....			●A63006	<b>1994-1991</b>			
Outlet Hose To Trans. (Lower); W/O Turbo.....		∅-A63000		<b>4-CYL. 2.0 L ENG.</b>			
Outlet Tube From Rad. (Lower).....		∅-A63004		Inlet (Upper).....			
Outlet Tube To Trans. (Lower); W/O Turbo.....		∅-A63004		Inlet Fitting To Trans. (Upper); W/3-Speed Trans. ....			
Tube Nut.....			●A63011	Outlet (Lower).....			
<b>1988</b>				Outlet Fitting To Trans. (Lower); W/3-Speed Trans. ....			
<b>V-6 2.8 L ENG.</b>				V-6 3.1 L ENG.			
Inlet Fitting To Trans. (Upper).....			●A63006	Inlet (Upper).....			
Inlet Tube From Rad. (Upper).....		∅-A63004		Inlet Fitting To Trans. (Upper); W/3-Speed Trans. ....			
Outlet Fitting To Trans. (Lower).....			●A63006	Outlet (Lower).....			
Outlet Hose To Trans. (Lower).....		∅-A63000		Outlet Fitting To Trans. (Lower); W/3-Speed Trans. ....			
Outlet Tube From Rad. (Lower).....		∅-A63004		V-6 3.4 L ENG.			
Outlet Tube To Trans. (Lower).....		∅-A63004		Inlet Fitting To Trans. (Lower).....			
Tube Nut.....			●A63011				
<b>LEMANS</b>				<b>1990-1987</b>			
<b>1993-1991</b>				<b>4-CYL. 2.0 L ENG.</b>			
<b>4-CYL. 1.6 L ENG.</b>				Inlet (Upper).....			
Banjo Seals.....			●A63102	Inlet Fitting To Trans. (Upper); W/3-Speed Trans. ....			
Banjo Washers.....			●A63101	Outlet (Lower).....			
Inlet Hose.....		∅-A63001		Outlet Fitting To Trans. (Lower); W/3-Speed Trans. ....			
Outlet Hose.....		∅-A63001		V-6 3.4 L ENG.			
<b>1990-1989</b>				<b>1990-1987</b>			
<b>4-CYL. 1.6 L ENG.; 4-CYL. 2.0 L ENG.</b>				<b>4-CYL. 2.0 L ENG.</b>			
Banjo Seals.....			●A63102	Inlet (Upper).....			
Banjo Washers.....			●A63101	Inlet Fitting To Trans. (Upper); W/3-Speed Trans. ....			
Inlet Hose.....		∅-A63001		Outlet (Lower).....			
Outlet Hose.....		∅-A63001		Outlet Fitting To Trans. (Lower); W/3-Speed Trans. ....			
<b>1988</b>				<b>SUNFIRE</b>			
<b>4-CYL. 1.6 L ENG.</b>				<b>2001-1995</b>			
Banjo Seals.....			●A63102	<b>4-CYL. 2.2 L ENG.</b>			
				Inlet (Upper); W/3-Speed Trans. ....			

② Two Required.      ④ Four Required.      ⑥ Six Required.      ∅ Cut To Fit.  
 ③ Three Required.    ⑤ Five Required.      ⑦ Seven Required.    ● As Required.

See Pages 1 - 10 for Engine Oil Cooler Applications.

## Transmission Oil Cooler Assemblies for Passenger Cars &amp; Light Trucks

Application	Assembly Number	Hoses & Tubes	Connectors & Fittings	Application	Assembly Number	Hoses & Tubes	Connectors & Fittings
<b>PONTIAC - Continued</b>				<b>PONTIAC - Continued</b>			
<b>SUNFIRE - Continued</b>				<b>6000</b>			
<b>2001-1995 - Continued</b>				<b>1991-1990</b>			
<b>4-CYL. 2.2 L ENG. - Continued</b>				<b>4-CYL. 2.5 L ENG.</b>			
Inlet Fitting To Trans. (Upper); W/3-Speed Trans.....	A61003		A63006	Inlet Fitting To Trans. (Upper).....			A63006
Outlet (Lower); W/3-Speed Trans....				Inlet Hose (Upper).....	≠ A63000		
Outlet Fitting To Trans. (Lower); W/3-Speed Trans.....			A63006	Inlet Tube (Upper).....	≠ A63004		A63006
<b>TRANS SPORT</b>				Outlet Fitting To Trans. (Lower).....			
<b>1998-1997</b>				Outlet Hose (Lower).....			
<b>V-6 3.4 L ENG.</b>				Outlet Tube (Lower).....			
Inlet Fitting To Trans. (Lower).....			A63007	Tube Nut.....			● A63011
Outlet Fitting To Trans. (Upper).....			A63008	<b>V-6 3.1 L ENG.</b>			
<b>1996</b>				Inlet Fitting To Trans. (Upper).....			
<b>V-6 3.4 L ENG.</b>				Inlet Hose (Upper).....			
Inlet Fitting To Trans. (Lower).....			A63007	Inlet Tube (Upper).....	≠ A63000		A63006
Outlet Fitting To Trans. (Upper).....			A63008	Outlet Hose (Lower).....	≠ A63004		
<b>1995-1992</b>				Outlet Tube (Lower).....			
<b>V-6 3.1 L ENG.</b>				Tube Nut.....			
Inlet Fitting To Trans. (Upper).....			A63006	<b>V-6 2.8 L ENG.; V-6 3.1 L ENG.</b>			
Inlet To Trans. (Upper).....	A61052			Inlet Fitting To Trans. (Upper).....			A63006
Inlet Tube From Rad. (Upper).....		≠ A63004		Inlet Hose (Upper).....	≠ A63000		
Outlet Fitting To Trans. (Lower).....	A61052		A63006	Inlet Tube (Upper).....	≠ A63004		
Outlet To Trans. (Lower).....				Outlet Fitting To Trans. (Lower); W/3-Speed Trans.....			A63006
Outlet Tube From Rad. (Lower).....		≠ A63004		Outlet Hose (Lower).....	≠ A63000		
Rad. Supply Tube (Upper To Lower)		≠ A63004	● A63011	Outlet Tube (Lower).....	≠ A63004		● A63011
Tube Nut.....				Tube Nut.....			
<b>V-6 3.8 L ENG.</b>				Outlet Fitting To Trans. (Lower).....			
Inlet Fitting To Trans. (Upper).....			A63007	<b>1987-1985</b>			
Inlet From Rad. (Lower); W/Aux. Cooler.....	B61054			<b>4-CYL. 2.5 L ENG.</b>			
Inlet From Rad. (Upper); W/O Aux. Cooler.....	B61053		A63008	Inlet Fitting To Trans. (Upper).....			A63006
Outlet Fitting To Trans. (Lower).....				Inlet Hose (Upper).....	≠ A63000		
Outlet Hose To Trans. (Upper); W/Aux. Cooler.....		≠ A63001		Inlet Tube (Upper).....	≠ A63004		A63006
Outlet Tube From Rad. (Lower); W/Aux. Cooler.....		≠ A63005	⊗ A63013	Outlet Fitting To Trans. (Lower).....			A63006
Tube Nut.....				Outlet Hose (Lower).....	≠ A63000		
<b>1991-1990</b>				Outlet Tube (Lower).....			
<b>V-6 3.1 L ENG.</b>				Tube Nut.....			
Inlet Fitting To Trans. (Upper).....			A63006	<b>V-6 2.8 L ENG.</b>			
Inlet To Trans. (Upper).....	A61052			Inlet Fitting To Trans. (Upper).....			A63006
Inlet Tube From Rad. (Upper).....		≠ A63004		Inlet Hose (Upper).....	≠ A63000		
Outlet Fitting To Trans. (Lower).....	A61052		A63006	Inlet Tube (Upper).....	≠ A63004		
Outlet To Trans. (Lower).....				Outlet Fitting To Trans. (Lower); W/3-Speed Trans.....			A63006
Outlet Tube From Rad. (Lower).....		≠ A63004		Outlet Hose (Lower).....	≠ A63000		
Rad. Supply Tube (Upper To Lower)		≠ A63004	● A63011	Outlet Tube (Lower).....	≠ A63004		● A63011
Tube Nut.....				Tube Nut.....			

② Two Required.  
③ Three Required.

④ Four Required.  
⑤ Five Required.

⑥ Six Required.  
⑦ Seven Required.

≠ Cut To Fit.  
● As Required.

See Pages 1 - 10 for Engine Oil Cooler Applications.



# Numerical Listing

## Oil Cooler Assemblies & End Fittings

### A61002

Chev; Cavalier; 2001-1995; 4-Cyl. 2.2 Eng.; Inlet (Upper); W/3-Spd Trans.  
Pont; Sunfire; 2001-1995; 4-Cyl. 2.2 Eng.; Inlet (Upper); W/3-Spd Trans.

### A61003

Chev; Cavalier; 2001-1995; 4-Cyl. 2.2 Eng.; Outlet (Lower); W/3-Spd Trans.  
Pont; Sunfire; 2001-1995; 4-Cyl. 2.2 Eng.; Outlet (Lower); W/3-Spd Trans.

### A61006

Chry; Grand Voyager; 2000; V-6 3.0 Eng.; Outlet (Lower); W/AC  
Chry; Grand Voyager; 2000; V-6 3.3 Eng.; Outlet (Lower); W/AC  
Chry; Town & Country Van; 2000; V-6 3.3 Eng.; Outlet (Lower); W/AC  
Chry; Town & Country Van; 1999; V-6 3.3 Eng.; Outlet (Lower); W/O Aux. Cooler  
Chry; Town & Country Van; 1998; V-6 3.3 Eng.; Outlet (Lower); W/Front AC  
Chry; Town & Country Van; 1997; V-6 3.3 Eng.; Outlet (Lower); W/4-Spd Trans.  
Chry; Town & Country Van; 2000; V-6 3.8 Eng.; Outlet (Lower); W/AC  
Chry; Town & Country Van; 1999; V-6 3.8 Eng.; Outlet (Lower); W/O Aux. Cooler  
Chry; Town & Country Van; 1998; V-6 3.8 Eng.; Outlet (Lower); W/Front AC  
Chry; Town & Country Van; 1997; V-6 3.8 Eng.; Outlet (Lower); W/4-Spd Trans.  
Chry; Voyager; 2000; V-6 3.0 Eng.; Outlet (Lower); W/AC  
Chry; Voyager; 2000; V-6 3.3 Eng.; Outlet (Lower); W/AC  
Dodge; Caravan; 2000; V-6 3.0 Eng.; Outlet (Lower); W/AC  
Dodge; Caravan; 1999; V-6 3.0 Eng.; Outlet (Lower)  
Dodge; Caravan; 1998; V-6 3.0 Eng.; Outlet (Lower); W/4-Spd Trans.; W/Front AC  
Dodge; Caravan; 2000; V-6 3.3 Eng.; Outlet (Lower); W/AC  
Dodge; Caravan; 1999; V-6 3.3 Eng.; Outlet (Lower)  
Dodge; Caravan; 1998; V-6 3.3 Eng.; Outlet (Lower); W/Front AC  
Dodge; Caravan; 1997; V-6 3.3 Eng.; Outlet (Lower); W/4-Spd Trans.  
Dodge; Caravan; 1999; V-6 3.8 Eng.; Outlet (Lower)  
Dodge; Caravan; 1998; V-6 3.8 Eng.; Outlet (Lower); W/Front AC  
Dodge; Caravan; 1997; V-6 3.8 Eng.; Outlet (Lower); W/4-Spd Trans.  
Dodge; Grand Caravan; 2000; V-6 3.0 Eng.; Outlet (Lower); W/AC  
Dodge; Grand Caravan; 1999; V-6 3.0 Eng.; Outlet (Lower)  
Dodge; Grand Caravan; 1998; V-6 3.0 Eng.; Outlet (Lower); W/4-Spd Trans.; W/Front AC  
Dodge; Grand Caravan; 2000; V-6 3.3 Eng.; Outlet (Lower); W/AC  
Dodge; Grand Caravan; 1999; V-6 3.3 Eng.; Outlet (Lower)  
Dodge; Grand Caravan; 1998; V-6 3.3 Eng.; Outlet (Lower); W/Front AC  
Dodge; Grand Caravan; 1997; V-6 3.3 Eng.; Outlet (Lower); W/4-Spd Trans.  
Dodge; Grand Caravan; 2000; V-6 3.8 Eng.; Outlet (Lower); W/AC  
Dodge; Grand Caravan; 1999; V-6 3.8 Eng.; Outlet (Lower)  
Dodge; Grand Caravan; 1998; V-6 3.8 Eng.; Outlet (Lower); W/Front AC  
Dodge; Grand Caravan; 1997; V-6 3.8 Eng.; Outlet (Lower); W/4-Spd Trans.  
Ply; Grand Voyager; 2000; V-6 3.0 Eng.; Outlet (Lower); W/AC  
Ply; Grand Voyager; 1999; V-6 3.0 Eng.; Outlet (Lower)  
Ply; Grand Voyager; 1998; V-6 3.0 Eng.; Outlet (Lower); W/4-Spd Trans.; W/Front AC  
Ply; Grand Voyager; 2000; V-6 3.3 Eng.; Outlet (Lower); W/AC  
Ply; Grand Voyager; 1999; V-6 3.3 Eng.; Outlet (Lower)  
Ply; Grand Voyager; 1998; V-6 3.3 Eng.; Outlet (Lower); W/Front AC  
Ply; Grand Voyager; 1997; V-6 3.3 Eng.; Outlet (Lower); W/4-Spd Trans.  
Ply; Grand Voyager; 1999; V-6 3.8 Eng.; Outlet (Lower)  
Ply; Grand Voyager; 1998; V-6 3.8 (Canada) Eng.; Outlet (Lower); W/Front AC  
Ply; Grand Voyager; 1997; V-6 3.8 (Canada) Eng.; Outlet (Lower); W/4-Spd Trans.  
Ply; Voyager; 2000; V-6 3.0 Eng.; Outlet (Lower); W/AC  
Ply; Voyager; 1999; V-6 3.0 Eng.; Outlet (Lower)  
Ply; Voyager; 1998; V-6 3.0 Eng.; Outlet (Lower); W/4-Spd Trans.; W/Front AC  
Ply; Voyager; 2000; V-6 3.3 Eng.; Outlet (Lower); W/AC  
Ply; Voyager; 1999; V-6 3.3 Eng.; Outlet (Lower)  
Ply; Voyager; 1998; V-6 3.3 Eng.; Outlet (Lower); W/Front AC  
Ply; Voyager; 1997; V-6 3.3 Eng.; Outlet (Lower); W/4-Spd Trans.  
Ply; Voyager; 1999; V-6 3.8 Eng.; Outlet (Lower)

### A61006 - Continued

Ply; Voyager; 1998; V-6 3.8 (Canada) Eng.; Outlet (Lower); W/Front AC  
Ply; Voyager; 1997; V-6 3.8 (Canada) Eng.; Outlet (Lower); W/4-Spd Trans.

### A61007

Chry; Grand Voyager; 2000; V-6 3.0 Eng.; Aux. Cooler Tube To Tube  
Chry; Grand Voyager; 2000; V-6 3.3 Eng.; Aux. Cooler Tube To Tube  
Chry; Town & Country Van; 2000-1997; V-6 3.3 Eng.; Aux. Cooler Tube To Tube  
Chry; Town & Country Van; 2000-1997; V-6 3.8 Eng.; Aux. Cooler Tube To Tube  
Chry; Voyager; 2000; V-6 3.0 Eng.; Aux. Cooler Tube To Tube  
Chry; Voyager; 2000; V-6 3.3 Eng.; Aux. Cooler Tube To Tube  
Dodge; Caravan; 2000-1999; V-6 3.0 Eng.; Aux. Cooler Tube To Tube  
Dodge; Caravan; 2000-1997; V-6 3.3 Eng.; Aux. Cooler Tube To Tube  
Dodge; Caravan; 1999-1997; V-6 3.8 Eng.; Aux. Cooler Tube To Tube  
Dodge; Grand Caravan; 2000-1999; V-6 3.0 Eng.; Aux. Cooler Tube To Tube  
Dodge; Grand Caravan; 2000-1997; V-6 3.3 Eng.; Aux. Cooler Tube To Tube  
Dodge; Grand Caravan; 2000-1997; V-6 3.8 Eng.; Aux. Cooler Tube To Tube  
Ply; Grand Voyager; 2000-1999; V-6 3.0 Eng.; Aux. Cooler Tube To Tube  
Ply; Grand Voyager; 2000-1997; V-6 3.3 Eng.; Aux. Cooler Tube To Tube  
Ply; Grand Voyager; 1999; V-6 3.8 Eng.; Aux. Cooler Tube To Tube  
Ply; Grand Voyager; 1998-1997; V-6 3.8 (Canada) Eng.; Aux. Cooler Tube To Tube  
Ply; Voyager; 2000-1999; V-6 3.0 Eng.; Aux. Cooler Tube To Tube  
Ply; Voyager; 2000-1997; V-6 3.3 Eng.; Aux. Cooler Tube To Tube  
Ply; Voyager; 1999; V-6 3.8 Eng.; Aux. Cooler Tube To Tube  
Ply; Voyager; 1998-1997; V-6 3.8 (Canada) Eng.; Aux. Cooler Tube To Tube

### A61008

Chry; Grand Voyager; 2000; V-6 3.0 Eng.; Outlet (Lower); W/O AC  
Chry; Grand Voyager; 2000; V-6 3.3 Eng.; Outlet (Lower); W/O AC  
Chry; Town & Country Van; 2000; V-6 3.3 Eng.; Outlet (Lower); W/O AC  
Chry; Town & Country Van; 1998; V-6 3.3 Eng.; Outlet (Lower); W/Rear AC  
Chry; Town & Country Van; 1997; V-6 3.3 Eng.; Outlet (Lower); W/Rear AC; W/4-Spd Trans.  
Chry; Town & Country Van; 2000; V-6 3.8 Eng.; Outlet (Lower); W/O AC  
Chry; Town & Country Van; 1998; V-6 3.8 Eng.; Outlet (Lower); W/Rear AC  
Chry; Voyager; 2000; V-6 3.0 Eng.; Outlet (Lower); W/O AC  
Chry; Voyager; 2000; V-6 3.3 Eng.; Outlet (Lower); W/O AC  
Dodge; Caravan; 1997; 4-Cyl. 2.4 Eng.; Outlet (Lower); W/4-Spd Trans.  
Dodge; Caravan; 2000; V-6 3.0 Eng.; Outlet (Lower); W/O AC  
Dodge; Caravan; 1998; V-6 3.0 Eng.; Outlet (Lower); W/4-Spd Trans.; W/O AC  
Dodge; Caravan; 2000; V-6 3.3 Eng.; Outlet (Lower); W/O AC  
Dodge; Caravan; 1998-1997; V-6 3.3 Eng.; Outlet (Lower); W/Rear AC  
Dodge; Grand Caravan; 2000; V-6 3.8 Eng.; Outlet (Lower); W/O AC  
Dodge; Grand Caravan; 1998-1997; V-6 3.8 Eng.; Outlet (Lower); W/Rear AC  
Ply; Grand Voyager; 1997; 4-Cyl. 2.4 Eng.; Outlet (Lower); W/4-Spd Trans.  
Ply; Grand Voyager; 2000; V-6 3.0 Eng.; Outlet (Lower); W/O AC  
Ply; Grand Voyager; 1998; V-6 3.0 Eng.; Outlet (Lower); W/4-Spd Trans.; W/O AC  
Ply; Grand Voyager; 2000; V-6 3.3 Eng.; Outlet (Lower); W/O AC  
Ply; Grand Voyager; 1998-1997; V-6 3.3 Eng.; Outlet (Lower); W/Rear AC  
Ply; Grand Voyager; 1998-1997; V-6 3.8 (Canada) Eng.; Outlet (Lower); W/Rear AC  
Ply; Voyager; 1997; 4-Cyl. 2.4 Eng.; Outlet (Lower); W/4-Spd Trans.

# Numerical Listing - Oil Cooler Assemblies & End Fittings

## A61008 - Continued

Ply; Voyager; 2000; V-6 3.0 Eng.; Outlet (Lower); W/O AC  
 Ply; Voyager; 1998; V-6 3.0 Eng.; Outlet (Lower); W/4-Spd Trans.; W/O AC  
 Ply; Voyager; 2000; V-6 3.3 Eng.; Outlet (Lower); W/O AC  
 Ply; Voyager; 1998-1997; V-6 3.3 Eng.; Outlet (Lower); W/Rear AC  
 Ply; Voyager; 1998-1997; V-6 3.8 (Canada) Eng.; Outlet (Lower); W/Rear AC

## A61014

Ford; Taurus; 1998-1997; V-6 3.0 Eng.; Inlet (Upper); W/Aux. Cooler; W/AX4N Trans.  
 Ford; Taurus; 1999-1997; V-8 3.4 Eng.; Inlet (Upper)  
 Merc; Sable; 1998-1997; V-6 3.0 Eng.; Inlet (Upper); W/Aux. Cooler; W/AX4N Trans.

## A61017

Ford; Expedition; 2002-2000; V-8 4.6 Eng.; Aux. Cooler Inlet Tube Fitting (Pass. Side); W/Super Cooling  
 Ford; Expedition; 1998-1997; V-8 4.6 Eng.; Aux. Cooler Inlet Tube Fitting (Pass. Side)  
 Ford; F Pickup; 2002; V-6 4.2 Eng.; Aux. Cooler Inlet Tube Fitting (Pass. Side); W/Super Cooling  
 Ford; F Pickup; 2001; V-6 4.2 Eng.; Aux. Cooler Inlet Tube (Pass. Side); W/Super Cooling  
 Ford; F Pickup; 2000; V-6 4.2 Eng.; Aux. Cooler Inlet Tube Fitting (Pass. Side); W/Super Cooling  
 Ford; F Pickup; 1998-1997; V-6 4.2 Eng.; Aux. Cooler Inlet Tube Fitting (Pass. Side)  
 Ford; F Pickup; 2002; V-8 4.6 Eng.; Aux. Cooler Inlet Tube Fitting (Pass. Side); W/Super Cooling  
 Ford; F Pickup; 2001; V-8 4.6 Eng.; Aux. Cooler Inlet Tube (Pass. Side); W/Super Cooling  
 Ford; F Pickup; 2000; V-8 4.6 Eng.; Aux. Cooler Inlet Tube Fitting (Pass. Side); W/Super Cooling  
 Ford; F Pickup; 1998-1997; V-8 4.6 Eng.; Aux. Cooler Inlet Tube Fitting (Pass. Side)  
 Ford; F Pickup; 2002; V-8 5.4 Eng.; Aux. Cooler Inlet Tube Fitting (Pass. Side); W/4R70W Trans.; W/Super Cooling  
 Ford; F Pickup; 2001; V-8 5.4 Eng.; Aux. Cooler Inlet Tube (Pass. Side); W/4R70W Trans.; W/Super Cooling  
 Ford; F Pickup; 2000; V-8 5.4 Eng.; Aux. Cooler Inlet Tube Fitting (Pass. Side); W/4R70W Trans.; W/Super Cooling  
 Ford; F Pickup; 1998-1997; V-8 5.4 Eng.; Aux. Cooler Inlet Tube Fitting (Pass. Side); W/4R70W Trans.

## A61019

Ford; Expedition; 2000-1997; V-8 5.4 Eng.; Aux. Cooler Inlet Tube Fitting (Pass. Side)  
 Ford; F Pickup; 2000-1998; V-8 5.4 Eng.; Aux. Cooler Inlet Tube Fitting (Pass. Side); W/4R100 Trans.  
 Ford; F Pickup; 1997; V-8 5.4 Eng.; Aux. Cooler Inlet Tube Fitting (Pass. Side); W/E4OD Trans.  
 Ford; F Pickup; 1997; V-8 5.8 Eng.; Aux. Cooler Inlet Tube Fitting (Pass. Side)  
 Ford; F Pickup; 1997; V-8 7.3 Diesel Eng.; Aux. Cooler Inlet Tube Fitting (Pass. Side)  
 Ford; F Pickup; 1997; V-8 7.5 Eng.; Aux. Cooler Inlet Tube Fitting (Pass. Side)  
 Ford; Super Duty Pickup; 1997; V-8 7.3 Diesel Eng.; Aux. Cooler Inlet Tube Fitting (Pass. Side)  
 Linc; Navigator; 2000-1998; V-8 5.4 Eng.; Aux. Cooler Inlet Tube Fitting (Pass. Side)

## A61022

Niss; Altima; 1998; 4-Cyl. 2.4 Eng.; Inlet (Driver Side); 7-31 & Older  
 Niss; Altima; 1997-1993; 4-Cyl. 2.4 Eng.; Inlet (Driver Side)

## A61023

Niss; Altima; 1996-1993; 4-Cyl. 2.4 Eng.; Outlet (Pass. Side)

## A61027

Chev; C&K Pickup; 2000-1996; V-8 5.7 Eng.; Aux. Cooler Inlet (Pass. Side); 3500HD  
 Chev; C&K Pickup; 2002-2001; V-8 6.5 Diesel Eng.; Aux. Cooler Inlet (Pass. Side)  
 Chev; C&K Pickup; 2000-1996; V-8 6.5 Diesel Eng.; Aux. Cooler Inlet (Pass. Side); 3500HD  
 Chev; C&K Pickup; 2000-1996; V-8 7.4 Eng.; Aux. Cooler Inlet (Pass. Side); 3500HD

## A61027 - Continued

Chev; Silverado Pickup; 1999; V-8 6.5 Diesel Eng.; Aux. Cooler Inlet (Pass. Side); 3500HD  
 GMC; C&K Pickup; 2000-1996; V-8 5.7 Eng.; Aux. Cooler Inlet (Pass. Side); 3500HD  
 GMC; C&K Pickup; 2002-2001; V-8 6.5 Diesel Eng.; Aux. Cooler Inlet (Pass. Side)  
 GMC; C&K Pickup; 2000-1996; V-8 6.5 Diesel Eng.; Aux. Cooler Inlet (Pass. Side); 3500HD  
 GMC; C&K Pickup; 2000-1996; V-8 7.4 Eng.; Aux. Cooler Inlet (Pass. Side); 3500HD  
 GMC; Sierra Pickup; 1999; V-8 6.5 Diesel Eng.; Aux. Cooler Inlet (Pass. Side); 3500HD

## A61028

Chev; C&K Pickup; 2000-1996; V-8 5.7 Eng.; Aux. Cooler Inlet (Pass. Side); Exc 3500HD; W/17-Bolt Trans. Pan (MT1)  
 Chev; C&K Pickup; 2000-1997; V-8 6.5 Diesel Eng.; Aux. Cooler Inlet (Pass. Side); Exc 3500HD  
 Chev; Silverado Pickup; 1999; V-8 6.5 Diesel Eng.; Aux. Cooler Inlet (Pass. Side); Exc 3500HD  
 Chev; Suburban; 1999-1996; V-8 5.7 Eng.; Aux. Cooler Inlet (Pass. Side); W/17-Bolt Trans. Pan (MT1)  
 Chev; Suburban; 1999-1997; V-8 6.5 Diesel Eng.; Aux. Cooler Inlet (Pass. Side)  
 Chev; Tahoe; 1996; V-8 5.7 Eng.; Aux. Cooler Inlet (Pass. Side); W/17-Bolt Trans. Pan (MT1)  
 Chev; Tahoe; 1999-1997; V-8 6.5 Diesel Eng.; Aux. Cooler Inlet (Pass. Side)  
 GMC; C&K Pickup; 2000-1996; V-8 5.7 Eng.; Aux. Cooler Inlet (Pass. Side); Exc 3500HD; W/17-Bolt Trans. Pan (MT1)  
 GMC; C&K Pickup; 2000-1997; V-8 6.5 Diesel Eng.; Aux. Cooler Inlet (Pass. Side); Exc 3500HD  
 GMC; Sierra Pickup; 1999; V-8 6.5 Diesel Eng.; Aux. Cooler Inlet (Pass. Side); Exc 3500HD  
 GMC; Suburban; 1999-1996; V-8 5.7 Eng.; Aux. Cooler Inlet (Pass. Side); W/17-Bolt Trans. Pan (MT1)  
 GMC; Suburban; 1999-1997; V-8 6.5 Diesel Eng.; Aux. Cooler Inlet (Pass. Side)  
 GMC; Yukon; 1999-1996; V-8 5.7 Eng.; Aux. Cooler Inlet (Pass. Side); W/17-Bolt Trans. Pan (MT1)  
 GMC; Yukon; 1997; V-8 6.5 Diesel Eng.; Aux. Cooler Inlet (Pass. Side)

## A61030

Buick; Century; 1997; V-6 3.1 Eng.; Outlet To Trans. (Lower)  
 Buick; Regal; 1996-1992; V-6 3.1 Eng.; Outlet To Trans. (Lower)  
 Buick; Regal; 1991; V-6 3.1 Eng.; Outlet To Trans. (Lower); W/3/8" Tubing  
 Buick; Regal; 1997-1990; V-6 3.8 Eng.; Outlet To Trans. (Lower)  
 Chev; Lumina; 1999-1998; V-6 3.1 Eng.; Outlet To Trans. (Lower); W/Aux. Cooler  
 Chev; Lumina; 1997-1994; V-6 3.1 Eng.; Outlet To Trans. (Lower)  
 Chev; Lumina; 1993-1991; V-6 3.1 Eng.; Outlet To Trans. (Lower); W/4-Spd Trans.  
 Chev; Lumina; 1997-1994; V-6 3.4 Eng.; Outlet To Trans. (Lower)  
 Chev; Lumina; 1993-1991; V-6 3.4 Eng.; Outlet To Trans. (Lower); W/4-Spd Trans.  
 Chev; Lumina; 1999-1998; V-6 3.8 Eng.; Outlet To Trans. (Lower); W/Aux. Cooler  
 Chev; Monte Carlo; 1999-1998; V-6 3.1 Eng.; Outlet To Trans. (Lower); W/Aux. Cooler  
 Chev; Monte Carlo; 1997-1995; V-6 3.1 Eng.; Outlet To Trans. (Lower)  
 Chev; Monte Carlo; 1997-1995; V-6 3.4 Eng.; Outlet To Trans. (Lower)  
 Chev; Monte Carlo; 1999-1998; V-6 3.8 Eng.; Outlet To Trans. (Lower); W/Aux. Cooler  
 Olds; Cutlass Supreme; 1997-1994; V-6 3.1 Eng.; Outlet To Trans. (Lower)  
 Olds; Cutlass Supreme; 1993-1991; V-6 3.1 Eng.; Outlet To Trans. (Lower); W/4-Spd Trans.  
 Olds; Cutlass Supreme; 1996-1994; V-6 3.4 Eng.; Outlet To Trans. (Lower)  
 Olds; Cutlass Supreme; 1993-1991; V-6 3.4 Eng.; Outlet To Trans. (Lower); W/4-Spd Trans.  
 Olds; Intrigue; 1998; V-6 3.8 Eng.; Outlet To Trans. (Lower); W/Aux. Cooler  
 Pont; Grand Prix; 1999-1998; V-6 3.1 Eng.; Outlet To Trans. (Lower); W/Aux. Cooler  
 Pont; Grand Prix; 1997-1994; V-6 3.1 Eng.; Outlet To Trans. (Lower)  
 Pont; Grand Prix; 1993-1991; V-6 3.1 Eng.; Outlet To Trans. (Lower); W/4-Spd Trans.  
 Pont; Grand Prix; 1996-1992; V-6 3.4 Eng.; Outlet To Trans. (Lower)  
 Pont; Grand Prix; 1991; V-6 3.4 Eng.; Outlet To Trans. (Lower); W/4-Spd Trans.

# Numerical Listing - Oil Cooler Assemblies & End Fittings

## A61030 - Continued

Pont; Grand Prix; 1999-1998; V-6 3.8 Eng.; Outlet To Trans. (Lower);  
W/Aux. Cooler  
Pont; Grand Prix; 1997; V-6 3.8 Eng.; Outlet To Trans. (Lower)

## A61031

Buick; Century; 1997; V-6 3.1 Eng.; Inlet To Trans. (Upper)  
Buick; Regal; 1996-1992; V-6 3.1 Eng.; Inlet To Trans. (Upper)  
Buick; Regal; 1991; V-6 3.1 Eng.; Inlet To Trans. (Upper); W/3/8" Tubing  
Buick; Regal; 1997-1990; V-6 3.8 Eng.; Inlet To Trans. (Upper)  
Chev; Lumina; 1999-1998; V-6 3.1 Eng.; Inlet To Trans. (Upper); W/Aux.  
Cooler  
Chev; Lumina; 1997-1994; V-6 3.1 Eng.; Inlet To Trans. (Upper)  
Chev; Lumina; 1993; V-6 3.1 Eng.; Inlet Tube To Trans. (Upper); W/4-Spd  
Trans.  
Chev; Lumina; 1992-1991; V-6 3.1 Eng.; Inlet To Trans. (Upper); W/4-Spd  
Trans.  
Chev; Lumina; 1997-1994; V-6 3.4 Eng.; Inlet To Trans. (Upper)  
Chev; Lumina; 1993-1991; V-6 3.4 Eng.; Inlet To Trans. (Upper); W/4-Spd  
Trans.  
Chev; Lumina; 1999-1998; V-6 3.8 Eng.; Inlet To Trans. (Upper); W/Aux.  
Cooler  
Chev; Monte Carlo; 1999-1998; V-6 3.1 Eng.; Inlet To Trans. (Upper);  
W/Aux. Cooler  
Chev; Monte Carlo; 1997-1995; V-6 3.1 Eng.; Inlet To Trans. (Upper)  
Chev; Monte Carlo; 1997-1995; V-6 3.4 Eng.; Inlet To Trans. (Upper)  
Chev; Monte Carlo; 1999-1998; V-6 3.8 Eng.; Inlet To Trans. (Upper);  
W/Aux. Cooler  
Olds; Cutlass Supreme; 1997-1994; V-6 3.1 Eng.; Inlet To Trans. (Upper)  
Olds; Cutlass Supreme; 1993-1991; V-6 3.1 Eng.; Inlet To Trans. (Upper);  
W/4-Spd Trans.  
Olds; Cutlass Supreme; 1996-1994; V-6 3.4 Eng.; Inlet To Trans. (Upper)  
Olds; Cutlass Supreme; 1993-1991; V-6 3.4 Eng.; Inlet To Trans. (Upper);  
W/4-Spd Trans.  
Olds; Intrigue; 1998; V-6 3.8 Eng.; Inlet To Trans. (Upper); W/Aux. Cooler  
Pont; Grand Prix; 1999-1998; V-6 3.1 Eng.; Inlet To Trans. (Upper);  
W/Aux. Cooler  
Pont; Grand Prix; 1997-1994; V-6 3.1 Eng.; Inlet To Trans. (Upper)  
Pont; Grand Prix; 1993-1991; V-6 3.1 Eng.; Inlet To Trans. (Upper);  
W/4-Spd Trans.  
Pont; Grand Prix; 1996-1992; V-6 3.4 Eng.; Inlet To Trans. (Upper)  
Pont; Grand Prix; 1991; V-6 3.4 Eng.; Inlet To Trans. (Upper); W/4-Spd  
Trans.  
Pont; Grand Prix; 1999-1998; V-6 3.8 Eng.; Inlet To Trans. (Upper);  
W/Aux. Cooler  
Pont; Grand Prix; 1997; V-6 3.8 Eng.; Inlet To Trans. (Upper)

## A61034

Buick; Electra; 1990-1988; V-6 3.8 Eng.; Inlet Tube To Trans. (Upper)  
Buick; Electra; 1989-1988; V-8 5.0 Eng.; Inlet Tube To Trans. (Upper)  
Buick; Lesabre; 1990-1988; V-6 3.8 Eng.; Inlet Tube To Trans. (Upper)  
Buick; Lesabre; 1990-1988; V-8 5.0 Eng.; Inlet Tube To Trans. (Upper)  
Olds; Delta 88; 1988; V-6 3.8 Eng.; Inlet Tube To Trans. (Upper)  
Olds; Eighty Eight; 1990-1989; V-6 3.8 Eng.; Inlet Tube To Trans. (Upper)  
Olds; Ninety Eight; 1990-1988; V-6 3.8 Eng.; Inlet Tube To Trans. (Upper)  
Pont; Bonneville; 1990-1988; V-6 3.8 Eng.; Inlet Tube To Trans. (Upper)

## A61035

Buick; Electra; 1990-1988; V-6 3.8 Eng.; Outlet Hose To Trans. (Lower)  
Buick; Electra; 1989-1988; V-8 5.0 Eng.; Outlet Hose To Trans. (Lower)  
Buick; Lesabre; 1990-1988; V-6 3.8 Eng.; Outlet Hose To Trans. (Lower)  
Buick; Lesabre; 1990-1988; V-8 5.0 Eng.; Outlet Hose To Trans. (Lower)  
Olds; Delta 88; 1988; V-6 3.8 Eng.; Outlet Hose To Trans. (Lower)  
Olds; Eighty Eight; 1990-1989; V-6 3.8 Eng.; Outlet Hose To Trans. (Lower)  
Olds; Ninety Eight; 1990-1988; V-6 3.8 Eng.; Outlet Hose To Trans. (Lower)  
Pont; Bonneville; 1990-1988; V-6 3.8 Eng.; Outlet Hose To Trans. (Lower)

## A61039

Chry; Cirrus; 1999-1995; V-6 2.5 Eng.; Outlet (Lower)  
Chry; Sebring; 1999; V-6 2.5 Eng.; Outlet (Driver Side); Convertible  
Chry; Sebring; 1998-1997; V-6 2.5 Eng.; Outlet (Pass. Side); Convertible  
Chry; Sebring; 1996-1995; V-6 2.5 Eng.; Outlet (Lower)  
Dodge; Stratus; 1999-1995; V-6 2.5 Eng.; Outlet (Lower)

## A61040

Chry; Cirrus; 1996-1995; 4-Cyl. 2.4 Eng.; Aux. Cooler Inlet Tube (Pass.  
Side)

## A61040 - Continued

Chry; Cirrus; 1996-1995; V-6 2.5 Eng.; Aux. Cooler Inlet Tube (Pass.  
Side)  
Chry; Sebring; 1996-1995; 4-Cyl. 2.0 Eng.; Aux. Cooler Inlet Tube (Pass.  
Side)  
Chry; Sebring; 1996; 4-Cyl. 2.4 Eng.; Aux. Cooler Inlet Tube (Pass. Side)  
Chry; Sebring; 1998-1997; V-6 2.5 Eng.; Aux. Cooler Inlet Tube (Driver  
Side); Convertible  
Chry; Sebring; 1996-1995; V-6 2.5 Eng.; Aux. Cooler Inlet Tube (Pass.  
Side)  
Dodge; Stratus; 1995; 4-Cyl. 2.0 Eng.; Aux. Cooler Inlet Tube (Pass. Side)  
Dodge; Stratus; 1995; 4-Cyl. 2.4 Eng.; Aux. Cooler Inlet Tube (Pass. Side)  
Dodge; Stratus; 1995; V-6 2.5 Eng.; Aux. Cooler Inlet Tube (Pass. Side)

## A61041

Chry; Cirrus; 1996-1995; 4-Cyl. 2.4 Eng.; Aux. Cooler Outlet Tube (Driver  
Side)  
Chry; Cirrus; 1996-1995; V-6 2.5 Eng.; Aux. Cooler Outlet Tube (Driver  
Side)  
Chry; Sebring; 1996-1995; 4-Cyl. 2.0 Eng.; Aux. Cooler Outlet Tube (Driver  
Side)  
Chry; Sebring; 1996; 4-Cyl. 2.4 Eng.; Aux. Cooler Outlet Tube (Driver  
Side)  
Chry; Sebring; 1998-1997; V-6 2.5 Eng.; Aux. Cooler Outlet Tube (Pass.  
Side); Convertible  
Chry; Sebring; 1996-1995; V-6 2.5 Eng.; Aux. Cooler Outlet Tube (Driver  
Side)  
Dodge; Stratus; 1995; 4-Cyl. 2.0 Eng.; Aux. Cooler Outlet Tube (Driver  
Side)  
Dodge; Stratus; 1995; 4-Cyl. 2.4 Eng.; Aux. Cooler Outlet Tube (Driver  
Side)  
Dodge; Stratus; 1995; V-6 2.5 Eng.; Aux. Cooler Outlet Tube (Driver Side)

## A61044

Buick; Electra; 1987-1986; V-6 3.8 Eng.; Inlet (Upper)  
Buick; Electra; 1987-1986; V-8 5.0 Eng.; Inlet (Upper)  
Buick; Lesabre; 1987-1986; V-6 3.8 Eng.; Inlet (Upper)  
Buick; Lesabre; 1987-1986; V-8 5.0 Eng.; Inlet (Upper)  
Olds; Delta 88; 1987-1986; V-6 3.8 Eng.; Inlet (Upper)  
Olds; Ninety Eight; 1987-1986; V-6 3.8 Eng.; Inlet (Upper)  
Pont; Bonneville; 1987-1986; V-6 3.8 Eng.; Inlet (Upper)

## A61045

Buick; Electra; 1987-1986; V-6 3.8 Eng.; Outlet (Lower)  
Buick; Electra; 1987-1986; V-8 5.0 Eng.; Outlet (Lower)  
Buick; Lesabre; 1987-1986; V-6 3.8 Eng.; Outlet (Lower)  
Buick; Lesabre; 1987-1986; V-8 5.0 Eng.; Outlet (Lower)  
Olds; Delta 88; 1987-1986; V-6 3.8 Eng.; Outlet (Lower)  
Olds; Ninety Eight; 1987-1986; V-6 3.8 Eng.; Outlet (Lower)  
Pont; Bonneville; 1987-1986; V-6 3.8 Eng.; Outlet (Lower)

## A61049

Dodge; Ram Pickup; 1996-1994; V-6 3.9 Eng.; Inlet Hose From Rad (Up-  
per); W/46RH Trans.  
Dodge; Ram Pickup; 2001; V-8 5.2 Eng.; Inlet Hose From Rad (Upper);  
W/Aux. Cooler  
Dodge; Ram Pickup; 2000; V-8 5.2 Eng.; Inlet Hose From Rad (Upper);  
W/Std. Cab; 1-16 & Older  
Dodge; Ram Pickup; 1995-1994; V-8 5.2 Eng.; Inlet Hose From Rad (Up-  
per); W/Sensor Port On Tube  
Dodge; Ram Pickup; 2003; V-8 5.9 Eng.; Inlet Hose From Rad (Upper)  
Dodge; Ram Pickup; 2001; V-8 5.9 Eng.; Inlet Hose From Rad (Upper);  
W/Aux. Cooler  
Dodge; Ram Pickup; 2000; V-8 5.9 Eng.; Inlet Hose From Rad (Upper);  
W/Std. Cab; 1-16 & Older  
Dodge; Ram Pickup; 1995-1994; V-8 5.9 Eng.; Inlet Hose From Rad (Up-  
per); W/Sensor Port On Tube

## A61052

Buick; Century; 1996-1994; 4-Cyl. 2.2 Eng.; Inlet To Trans. (Upper)  
Buick; Century; 1996-1994; 4-Cyl. 2.2 Eng.; Outlet To Trans. (Lower)  
Chev; Lumina APV; 1995-1990; V-6 3.1 Eng.; Inlet To Trans. (Upper)  
Chev; Lumina APV; 1995-1990; V-6 3.1 Eng.; Outlet To Trans. (Lower)  
Olds; Silhouette; 1994-1990; V-6 3.1 Eng.; Inlet To Trans. (Upper)  
Olds; Silhouette; 1994-1990; V-6 3.1 Eng.; Outlet To Trans. (Lower)  
Pont; Trans Sport; 1995-1990; V-6 3.1 Eng.; Inlet To Trans. (Upper)  
Pont; Trans Sport; 1995-1990; V-6 3.1 Eng.; Outlet To Trans. (Lower)

# Numerical Listing - Oil Cooler Assemblies & End Fittings

## A61061

Dodge; Caravan; 1995-1993; 4-Cyl. 2.5 Eng.; Inlet (Upper); W/Water Cooled Trans. Cooler  
 Dodge; Caravan; 1995-1994; V-6 3.0 Eng.; Outlet (Lower); W/Water Cooled Trans. Cooler; W/3-Spd Trans.; W/O Rear AC  
 Dodge; Grand Caravan; 1994; V-6 3.0 Eng.; Outlet (Lower); W/Water Cooled Trans. Cooler; W/3-Spd Trans.; W/O Rear AC  
 Ply; Grand Voyager; 1994; V-6 3.0 Eng.; Outlet (Lower); W/Water Cooled Trans. Cooler; W/3-Spd Trans.; W/O Rear AC  
 Ply; Voyager; 1995-1993; 4-Cyl. 2.5 Eng.; Inlet (Upper); W/Water Cooled Trans. Cooler  
 Ply; Voyager; 1995-1994; V-6 3.0 Eng.; Outlet (Lower); W/Water Cooled Trans. Cooler; W/3-Spd Trans.; W/O Rear AC

## A61062

Dodge; Caravan; 1995-1993; 4-Cyl. 2.5 Eng.; Outlet (Lower); W/Water Cooled Trans. Cooler  
 Dodge; Caravan; 1995-1994; V-6 3.0 Eng.; Inlet (Upper); W/Water Cooled Trans. Cooler; W/3-Spd Trans.; W/O Rear AC  
 Dodge; Grand Caravan; 1994; V-6 3.0 Eng.; Inlet (Upper); W/Water Cooled Trans. Cooler; W/3-Spd Trans.; W/O Rear AC  
 Ply; Grand Voyager; 1994; V-6 3.0 Eng.; Inlet (Upper); W/Water Cooled Trans. Cooler; W/3-Spd Trans.; W/O Rear AC  
 Ply; Voyager; 1995-1993; 4-Cyl. 2.5 Eng.; Outlet (Lower); W/Water Cooled Trans. Cooler  
 Ply; Voyager; 1995-1994; V-6 3.0 Eng.; Inlet (Upper); W/Water Cooled Trans. Cooler; W/3-Spd Trans.; W/O Rear AC

## A61063

Chry; Town & Country Van; 1993; V-6 3.3 Eng.; Inlet Hose; W/Air Cooled Trans. Cooler  
 Chry; Town & Country Van; 1995-1994; V-6 3.8 Eng.; Inlet Hose; W/Air Cooled Trans. Cooler  
 Dodge; Caravan; 1995-1993; 4-Cyl. 2.5 Eng.; Inlet Hose; W/Air Cooled Trans. Cooler  
 Dodge; Caravan; 1995-1993; V-6 3.0 Eng.; Inlet Hose; W/Air Cooled Trans. Cooler  
 Dodge; Caravan; 1995-1993; V-6 3.3 Eng.; Inlet Hose; W/Air Cooled Trans. Cooler  
 Dodge; Grand Caravan; 1995-1993; V-6 3.0 Eng.; Inlet Hose; W/Air Cooled Trans. Cooler  
 Dodge; Grand Caravan; 1995-1993; V-6 3.3 Eng.; Inlet Hose; W/Air Cooled Trans. Cooler  
 Dodge; Grand Caravan; 1995-1994; V-6 3.8 Eng.; Inlet Hose; W/Air Cooled Trans. Cooler  
 Ply; Grand Voyager; 1995-1993; V-6 3.0 Eng.; Inlet Hose; W/Air Cooled Trans. Cooler  
 Ply; Grand Voyager; 1995-1993; V-6 3.3 Eng.; Inlet Hose; W/Air Cooled Trans. Cooler  
 Ply; Grand Voyager; 1995-1994; V-6 3.8 Eng.; Inlet Hose; W/Air Cooled Trans. Cooler  
 Ply; Voyager; 1995-1993; 4-Cyl. 2.5 Eng.; Inlet Hose; W/Air Cooled Trans. Cooler  
 Ply; Voyager; 1995-1993; V-6 3.0 Eng.; Inlet Hose; W/Air Cooled Trans. Cooler  
 Ply; Voyager; 1995-1993; V-6 3.3 Eng.; Inlet Hose; W/Air Cooled Trans. Cooler

## A61069

Ford; Taurus; 1998-1996; V-6 3.0 Eng.; Outlet (Lower); W/Aux. Cooler; W/AX4N Trans.  
 Ford; Taurus; 1999-1996; V-8 3.4 Eng.; Outlet (Lower)  
 Merc; Sable; 1998-1996; V-6 3.0 Eng.; Outlet (Lower); W/Aux. Cooler; W/AX4N Trans.

## A61070

Ford; Taurus; 1996; V-6 3.0 Eng.; Inlet (Upper); W/Aux. Cooler; W/AX4S Trans.  
 Merc; Sable; 1996; V-6 3.0 Eng.; Inlet (Upper); W/Aux. Cooler; W/AX4S Trans.

## A61071

Ford; Taurus; 1998-1996; V-6 3.0 Eng.; Outlet (Lower); W/Aux. Cooler; W/AX4S Trans.  
 Merc; Sable; 1998-1996; V-6 3.0 Eng.; Outlet (Lower); W/Aux. Cooler; W/AX4S Trans.

## A61072

Chry; Concorde; 1996-1993; V-6 3.3 Eng.; Aux. Cooler Inlet (Pass. Side)  
 Chry; Concorde; 1997-1993; V-6 3.5 Eng.; Aux. Cooler Inlet (Pass. Side)

## A61072 - Continued

Chry; LHS; 1997-1994; V-6 3.5 Eng.; Aux. Cooler Inlet (Pass. Side)  
 Chry; New Yorker; 1996-1994; V-6 3.5 Eng.; Aux. Cooler Inlet (Pass. Side)  
 Dodge; Intrepid; 1997-1993; V-6 3.3 Eng.; Aux. Cooler Inlet (Pass. Side)  
 Dodge; Intrepid; 1997-1993; V-6 3.5 Eng.; Aux. Cooler Inlet (Pass. Side)  
 Eagle; Vision; 1996-1993; V-6 3.3 Eng.; Aux. Cooler Inlet (Pass. Side)  
 Eagle; Vision; 1997; V-6 3.3 (Canada) Eng.; Aux. Cooler Inlet (Pass. Side)  
 Eagle; Vision; 1997-1993; V-6 3.5 Eng.; Aux. Cooler Inlet (Pass. Side)

## A61074

Chry; Town & Country Van; 2000; V-6 3.3 Eng.; Inlet (Upper); W/O AC  
 Chry; Town & Country Van; 1998; V-6 3.3 Eng.; Inlet (Upper); W/Rear AC  
 Chry; Town & Country Van; 1997; V-6 3.3 Eng.; Inlet (Upper); W/Rear AC; W/4-Spd Trans.  
 Chry; Town & Country Van; 2000; V-6 3.8 Eng.; Inlet (Upper); W/O AC  
 Chry; Town & Country Van; 1998; V-6 3.8 Eng.; Inlet (Upper); W/Rear AC  
 Dodge; Caravan; 1997; 4-Cyl. 2.4 Eng.; Inlet (Upper); W/4-Spd Trans.  
 Dodge; Caravan; 1998; V-6 3.0 Eng.; Inlet (Upper); W/4-Spd Trans.; W/O AC  
 Dodge; Caravan; 1998-1997; V-6 3.3 Eng.; Inlet (Upper); W/Rear AC  
 Dodge; Caravan; 1998-1997; V-6 3.8 Eng.; Inlet (Upper); W/Rear AC  
 Dodge; Grand Caravan; 1997; 4-Cyl. 2.4 Eng.; Inlet (Upper); W/4-Spd Trans.  
 Dodge; Grand Caravan; 1998; V-6 3.0 Eng.; Inlet (Upper); W/4-Spd Trans.; W/O AC  
 Dodge; Grand Caravan; 1998-1997; V-6 3.3 Eng.; Inlet (Upper); W/Rear AC  
 Dodge; Grand Caravan; 1998-1997; V-6 3.8 Eng.; Inlet (Upper); W/Rear AC  
 Dodge; Grand Caravan; 1998-1997; V-6 3.8 Eng.; Inlet (Upper); W/Rear AC  
 Ply; Grand Voyager; 1997; 4-Cyl. 2.4 Eng.; Inlet (Upper); W/4-Spd Trans.  
 Ply; Grand Voyager; 1998; V-6 3.0 Eng.; Inlet (Upper); W/4-Spd Trans.; W/O AC  
 Ply; Grand Voyager; 1998-1997; V-6 3.3 Eng.; Inlet (Upper); W/Rear AC  
 Ply; Grand Voyager; 1998-1997; V-6 3.8 (Canada) Eng.; Inlet (Upper); W/Rear AC  
 Ply; Voyager; 1997; 4-Cyl. 2.4 Eng.; Inlet (Upper); W/4-Spd Trans.  
 Ply; Voyager; 1998; V-6 3.0 Eng.; Inlet (Upper); W/4-Spd Trans.; W/O AC  
 Ply; Voyager; 1998-1997; V-6 3.3 Eng.; Inlet (Upper); W/Rear AC  
 Ply; Voyager; 1998-1997; V-6 3.8 (Canada) Eng.; Inlet (Upper); W/Rear AC

## A61075

Dodge; Neon; 1999-1995; 4-Cyl. 2.0 Eng.; Inlet Hose (Pass. Side); W/O AC  
 Ply; Neon; 1999-1995; 4-Cyl. 2.0 Eng.; Inlet Hose (Pass. Side); W/O AC

## A61076

Dodge; Neon; 1999-1995; 4-Cyl. 2.0 Eng.; Outlet Hose (Driver Side); W/O AC  
 Ply; Neon; 1999-1995; 4-Cyl. 2.0 Eng.; Outlet Hose (Driver Side); W/O AC

## A61077

Dodge; Neon; 1999-1995; 4-Cyl. 2.0 Eng.; Inlet Hose (Pass. Side); W/AC  
 Ply; Neon; 1999-1995; 4-Cyl. 2.0 Eng.; Inlet Hose (Pass. Side); W/AC

## A61078

Dodge; Neon; 1999-1995; 4-Cyl. 2.0 Eng.; Outlet Hose (Driver Side); W/AC  
 Ply; Neon; 1999-1995; 4-Cyl. 2.0 Eng.; Outlet Hose (Driver Side); W/AC

## A61079

Chry; Cirrus; 1997-1995; 4-Cyl. 2.4 Eng.; Inlet (Pass. Side)  
 Chry; Sebring; 1996-1995; 4-Cyl. 2.0 Eng.; Inlet (Pass. Side)  
 Chry; Sebring; 1999-1997; 4-Cyl. 2.4 Eng.; Inlet (Lower)  
 Chry; Sebring; 1996; 4-Cyl. 2.4 Eng.; Inlet (Pass. Side)  
 Dodge; Stratus; 1997-1995; 4-Cyl. 2.0 Eng.; Inlet (Pass. Side)  
 Dodge; Stratus; 1997-1995; 4-Cyl. 2.4 Eng.; Inlet (Pass. Side)  
 Ply; Breeze; 1997-1996; 4-Cyl. 2.0 Eng.; Inlet (Pass. Side)

## A61080

Chry; Cirrus; 1997-1995; 4-Cyl. 2.4 Eng.; Outlet (Driver Side)  
 Chry; Sebring; 1996-1995; 4-Cyl. 2.0 Eng.; Outlet (Driver Side)  
 Chry; Sebring; 1999-1997; 4-Cyl. 2.4 Eng.; Outlet (Upper)  
 Chry; Sebring; 1996; 4-Cyl. 2.4 Eng.; Outlet (Driver Side)  
 Dodge; Stratus; 1997-1995; 4-Cyl. 2.0 Eng.; Outlet (Driver Side)  
 Dodge; Stratus; 1997-1995; 4-Cyl. 2.4 Eng.; Outlet (Driver Side)  
 Ply; Breeze; 1997-1996; 4-Cyl. 2.0 Eng.; Outlet (Driver Side)



## Numerical Listing - Oil Cooler Assemblies & End Fittings

### A61091 - Continued

Dodge; Grand Caravan; 1995-1994; V-6 3.3 Eng.; Inlet (Upper); W/Water Cooled Trans. Cooler; W/O AC  
 Dodge; Grand Caravan; 1993; V-6 3.3 Eng.; Inlet (Upper); W/Water Cooled Trans. Cooler  
 Dodge; Grand Caravan; 1995-1994; V-6 3.8 Eng.; Inlet (Upper); W/Water Cooled Trans. Cooler; W/O AC  
 Ply; Grand Voyager; 1995-1994; V-6 3.3 Eng.; Inlet (Upper); W/Water Cooled Trans. Cooler; W/O AC  
 Ply; Grand Voyager; 1993; V-6 3.3 Eng.; Inlet (Upper); W/Water Cooled Trans. Cooler  
 Ply; Grand Voyager; 1995-1994; V-6 3.8 Eng.; Inlet (Upper); W/Water Cooled Trans. Cooler; W/O AC  
 Ply; Voyager; 1995-1994; V-6 3.3 Eng.; Inlet (Upper); W/Water Cooled Trans. Cooler; W/O AC  
 Ply; Voyager; 1993; V-6 3.3 Eng.; Inlet (Upper); W/Water Cooled Trans. Cooler

### A61092

Chry; Town & Country Van; 1993; V-6 3.3 Eng.; Outlet (Lower); W/Water Cooled Trans. Cooler; W/AC  
 Chry; Town & Country Van; 1995-1994; V-6 3.8 Eng.; Outlet (Lower); W/Water Cooled Trans. Cooler; W/AC  
 Dodge; Caravan; 1995-1994; V-6 3.0 Eng.; Outlet (Lower); W/Water Cooled Trans. Cooler; W/4-Spd Trans.; W/AC  
 Dodge; Caravan; 1995-1994; V-6 3.3 Eng.; Outlet (Lower); W/Water Cooled Trans. Cooler; W/AC  
 Dodge; Grand Caravan; 1995; V-6 3.0 Eng.; Outlet (Lower); W/Water Cooled Trans. Cooler; W/AC  
 Dodge; Grand Caravan; 1994; V-6 3.0 Eng.; Outlet (Lower); W/Water Cooled Trans. Cooler; W/4-Spd Trans.; W/AC  
 Dodge; Grand Caravan; 1995-1994; V-6 3.3 Eng.; Outlet (Lower); W/Water Cooled Trans. Cooler; W/AC  
 Dodge; Grand Caravan; 1995-1994; V-6 3.8 Eng.; Outlet (Lower); W/Water Cooled Trans. Cooler; W/AC  
 Ply; Grand Voyager; 1995; V-6 3.0 Eng.; Outlet (Lower); W/Water Cooled Trans. Cooler; W/AC  
 Ply; Grand Voyager; 1994; V-6 3.0 Eng.; Outlet (Lower); W/Water Cooled Trans. Cooler; W/4-Spd Trans.; W/AC  
 Ply; Grand Voyager; 1995-1994; V-6 3.3 Eng.; Outlet (Lower); W/Water Cooled Trans. Cooler; W/AC  
 Ply; Grand Voyager; 1995-1994; V-6 3.8 Eng.; Outlet (Lower); W/Water Cooled Trans. Cooler; W/AC  
 Ply; Voyager; 1995-1994; V-6 3.0 Eng.; Outlet (Lower); W/Water Cooled Trans. Cooler; W/4-Spd Trans.; W/AC  
 Ply; Voyager; 1995-1994; V-6 3.3 Eng.; Outlet (Lower); W/Water Cooled Trans. Cooler; W/AC

### A61093

Dodge; Caravan; 1995-1994; V-6 3.0 Eng.; Inlet (Upper); W/Water Cooled Trans. Cooler; W/4-Spd Trans.; W/AC  
 Dodge; Grand Caravan; 1995; V-6 3.0 Eng.; Inlet (Upper); W/Water Cooled Trans. Cooler; W/AC  
 Dodge; Grand Caravan; 1994; V-6 3.0 Eng.; Inlet (Upper); W/Water Cooled Trans. Cooler; W/4-Spd Trans.; W/AC  
 Ply; Grand Voyager; 1995; V-6 3.0 Eng.; Inlet (Upper); W/Water Cooled Trans. Cooler; W/AC  
 Ply; Grand Voyager; 1994; V-6 3.0 Eng.; Inlet (Upper); W/Water Cooled Trans. Cooler; W/4-Spd Trans.; W/AC  
 Ply; Voyager; 1995-1994; V-6 3.0 Eng.; Inlet (Upper); W/Water Cooled Trans. Cooler; W/4-Spd Trans.; W/AC

### A61094

Chry; Town & Country Van; 1993; V-6 3.3 Eng.; Inlet (Upper); W/Water Cooled Trans. Cooler; W/AC  
 Chry; Town & Country Van; 1995-1994; V-6 3.8 Eng.; Inlet (Upper); W/Water Cooled Trans. Cooler; W/AC  
 Dodge; Caravan; 1995-1994; V-6 3.3 Eng.; Inlet (Upper); W/Water Cooled Trans. Cooler; W/AC  
 Dodge; Grand Caravan; 1995-1994; V-6 3.3 Eng.; Inlet (Upper); W/Water Cooled Trans. Cooler; W/AC  
 Dodge; Grand Caravan; 1995-1994; V-6 3.8 Eng.; Inlet (Upper); W/Water Cooled Trans. Cooler; W/AC  
 Ply; Grand Voyager; 1995-1994; V-6 3.3 Eng.; Inlet (Upper); W/Water Cooled Trans. Cooler; W/AC  
 Ply; Grand Voyager; 1995-1994; V-6 3.8 Eng.; Inlet (Upper); W/Water Cooled Trans. Cooler; W/AC  
 Ply; Voyager; 1995-1994; V-6 3.3 Eng.; Inlet (Upper); W/Water Cooled Trans. Cooler; W/AC

### A61095

Chry; Town & Country Van; 1997; V-6 3.3 Eng.; Outlet (Lower); W/HD Rad.; W/O Trlr Tow Pkg  
 Dodge; Caravan; 1998; V-6 3.0 Eng.; Outlet (Lower); W/4-Spd Trans.; W/Rear AC  
 Dodge; Caravan; 1997; V-6 3.0 Eng.; Outlet (Lower); W/HD Rad.  
 Dodge; Caravan; 1997; V-6 3.3 Eng.; Outlet (Lower); W/HD Rad.; W/O Trlr Tow Pkg  
 Dodge; Caravan; 1997; V-6 3.8 Eng.; Outlet (Lower); W/HD Rad.; W/O Trlr Tow Pkg  
 Dodge; Grand Caravan; 1998; V-6 3.0 Eng.; Outlet (Lower); W/4-Spd Trans.; W/Rear AC  
 Dodge; Grand Caravan; 1997; V-6 3.0 Eng.; Outlet (Lower); W/HD Rad.  
 Dodge; Grand Caravan; 1997; V-6 3.3 Eng.; Outlet (Lower); W/HD Rad.; W/O Trlr Tow Pkg  
 Dodge; Grand Caravan; 1997; V-6 3.8 Eng.; Outlet (Lower); W/HD Rad.; W/O Trlr Tow Pkg  
 Ply; Grand Voyager; 1998; V-6 3.0 Eng.; Outlet (Lower); W/4-Spd Trans.; W/Rear AC  
 Ply; Grand Voyager; 1997; V-6 3.0 Eng.; Outlet (Lower); W/HD Rad.  
 Ply; Grand Voyager; 1997; V-6 3.3 Eng.; Outlet (Lower); W/HD Rad.; W/O Trlr Tow Pkg  
 Ply; Grand Voyager; 1997; V-6 3.8 (Canada) Eng.; Outlet (Lower); W/HD Rad.; W/O Trlr Tow Pkg  
 Ply; Voyager; 1998; V-6 3.0 Eng.; Outlet (Lower); W/4-Spd Trans.; W/Rear AC  
 Ply; Voyager; 1997; V-6 3.0 Eng.; Outlet (Lower); W/HD Rad.  
 Ply; Voyager; 1997; V-6 3.3 Eng.; Outlet (Lower); W/HD Rad.; W/O Trlr Tow Pkg  
 Ply; Voyager; 1997; V-6 3.8 (Canada) Eng.; Outlet (Lower); W/HD Rad.; W/O Trlr Tow Pkg

### A61096

Chry; Town & Country Van; 1997; V-6 3.3 Eng.; Inlet (Upper); W/HD Rad.; W/O Trlr Tow Pkg  
 Dodge; Caravan; 1998; V-6 3.0 Eng.; Inlet (Upper); W/4-Spd Trans.; W/Rear AC  
 Dodge; Caravan; 1997; V-6 3.0 Eng.; Inlet (Upper); W/HD Rad.  
 Dodge; Caravan; 1997; V-6 3.3 Eng.; Inlet (Upper); W/HD Rad.; W/O Trlr Tow Pkg  
 Dodge; Caravan; 1997; V-6 3.8 Eng.; Inlet (Upper); W/HD Rad.; W/O Trlr Tow Pkg  
 Dodge; Grand Caravan; 1998; V-6 3.0 Eng.; Inlet (Upper); W/4-Spd Trans.; W/Rear AC  
 Dodge; Grand Caravan; 1997; V-6 3.0 Eng.; Inlet (Upper); W/HD Rad.  
 Dodge; Grand Caravan; 1997; V-6 3.3 Eng.; Inlet (Upper); W/HD Rad.; W/O Trlr Tow Pkg  
 Dodge; Grand Caravan; 1997; V-6 3.8 Eng.; Inlet (Upper); W/HD Rad.; W/O Trlr Tow Pkg  
 Ply; Grand Voyager; 1998; V-6 3.0 Eng.; Inlet (Upper); W/4-Spd Trans.; W/Rear AC  
 Ply; Grand Voyager; 1997; V-6 3.0 Eng.; Inlet (Upper); W/HD Rad.  
 Ply; Grand Voyager; 1997; V-6 3.3 Eng.; Inlet (Upper); W/HD Rad.; W/O Trlr Tow Pkg  
 Ply; Grand Voyager; 1997; V-6 3.8 (Canada) Eng.; Inlet (Upper); W/HD Rad.; W/O Trlr Tow Pkg  
 Ply; Voyager; 1998; V-6 3.0 Eng.; Inlet (Upper); W/4-Spd Trans.; W/Rear AC  
 Ply; Voyager; 1997; V-6 3.0 Eng.; Inlet (Upper); W/HD Rad.  
 Ply; Voyager; 1997; V-6 3.3 Eng.; Inlet (Upper); W/HD Rad.; W/O Trlr Tow Pkg  
 Ply; Voyager; 1997; V-6 3.8 (Canada) Eng.; Inlet (Upper); W/HD Rad.; W/O Trlr Tow Pkg

### A61097

Dodge; Ram Pickup; 2000-1994; 6-Cyl. 5.9 Diesel Eng.; Aux. Cooler Outlet (Driver Side)

### A61098

Dodge; Ram Pickup; 2000-1994; 6-Cyl. 5.9 Diesel Eng.; Aux. Cooler Inlet (Pass. Side)

### A61099

Jeep; Grand Cherokee; 1997-1994; 6-Cyl. 4.0 Eng.; Aux. Cooler Hose Elbow; 2 Req'd  
 Jeep; Grand Cherokee; 1997-1993; V-8 5.2 Eng.; Aux. Cooler Hose Elbow; 2 Req'd  
 Jeep; Wrangler; 1995-1994; 4-Cyl. 2.5 Eng.; Aux. Cooler Hose Elbow (Upper)  
 Jeep; Wrangler; 1995-1994; 6-Cyl. 4.0 Eng.; Aux. Cooler Hose Elbow (Upper)

# Numerical Listing - Oil Cooler Assemblies & End Fittings

## A61102

Chry; Grand Voyager; 2000; V-6 3.0 Eng.; Inlet (Upper)  
 Chry; Grand Voyager; 2000; V-6 3.3 Eng.; Inlet (Upper)  
 Chry; Town & Country Van; 2000; V-6 3.3 Eng.; Inlet (Upper); W/AC  
 Chry; Town & Country Van; 1999; V-6 3.3 Eng.; Inlet (Upper); W/O Aux. Cooler  
 Chry; Town & Country Van; 1998; V-6 3.3 Eng.; Inlet (Upper); W/Front AC  
 Chry; Town & Country Van; 1997; V-6 3.3 Eng.; Inlet (Upper); W/4-Spd Trans.  
 Chry; Town & Country Van; 2000; V-6 3.8 Eng.; Inlet (Upper); W/AC  
 Chry; Town & Country Van; 1999; V-6 3.8 Eng.; Inlet (Upper); W/O Aux. Cooler  
 Chry; Town & Country Van; 1998; V-6 3.8 Eng.; Inlet (Upper); W/Front AC  
 Chry; Town & Country Van; 1997; V-6 3.8 Eng.; Inlet (Upper); W/4-Spd Trans.  
 Chry; Voyager; 2000; V-6 3.0 Eng.; Inlet (Upper)  
 Chry; Voyager; 2000; V-6 3.3 Eng.; Inlet (Upper)  
 Dodge; Caravan; 2000-1999; V-6 3.0 Eng.; Inlet (Upper)  
 Dodge; Caravan; 1998; V-6 3.0 Eng.; Inlet (Upper); W/4-Spd Trans.; W/Front AC  
 Dodge; Caravan; 2000-1999; V-6 3.3 Eng.; Inlet (Upper)  
 Dodge; Caravan; 1998; V-6 3.3 Eng.; Inlet (Upper); W/Front AC  
 Dodge; Caravan; 1997; V-6 3.3 Eng.; Inlet (Upper); W/4-Spd Trans.  
 Dodge; Caravan; 1999; V-6 3.8 Eng.; Inlet (Upper)  
 Dodge; Caravan; 1998; V-6 3.8 Eng.; Inlet (Upper); W/Front AC  
 Dodge; Caravan; 1997; V-6 3.8 Eng.; Inlet (Upper); W/4-Spd Trans.  
 Dodge; Grand Caravan; 2000-1999; V-6 3.0 Eng.; Inlet (Upper)  
 Dodge; Grand Caravan; 1998; V-6 3.0 Eng.; Inlet (Upper); W/4-Spd Trans.; W/Front AC  
 Dodge; Grand Caravan; 2000-1999; V-6 3.3 Eng.; Inlet (Upper)  
 Dodge; Grand Caravan; 1998; V-6 3.3 Eng.; Inlet (Upper); W/Front AC  
 Dodge; Grand Caravan; 1997; V-6 3.3 Eng.; Inlet (Upper); W/4-Spd Trans.  
 Dodge; Grand Caravan; 2000-1999; V-6 3.8 Eng.; Inlet (Upper)  
 Dodge; Grand Caravan; 1998; V-6 3.8 Eng.; Inlet (Upper); W/Front AC  
 Dodge; Grand Caravan; 1997; V-6 3.8 Eng.; Inlet (Upper); W/4-Spd Trans.  
 Ply; Grand Voyager; 2000-1999; V-6 3.0 Eng.; Inlet (Upper)  
 Ply; Grand Voyager; 1998; V-6 3.0 Eng.; Inlet (Upper); W/4-Spd Trans.; W/Front AC  
 Ply; Grand Voyager; 2000-1999; V-6 3.3 Eng.; Inlet (Upper)  
 Ply; Grand Voyager; 1998; V-6 3.3 Eng.; Inlet (Upper); W/Front AC  
 Ply; Grand Voyager; 1997; V-6 3.3 Eng.; Inlet (Upper); W/4-Spd Trans.  
 Ply; Grand Voyager; 1999; V-6 3.8 Eng.; Inlet (Upper)  
 Ply; Grand Voyager; 1998; V-6 3.8 (Canada) Eng.; Inlet (Upper); W/Front AC  
 Ply; Grand Voyager; 1997; V-6 3.8 (Canada) Eng.; Inlet (Upper); W/4-Spd Trans.  
 Ply; Voyager; 2000-1999; V-6 3.0 Eng.; Inlet (Upper)  
 Ply; Voyager; 1998; V-6 3.0 Eng.; Inlet (Upper); W/4-Spd Trans.; W/Front AC  
 Ply; Voyager; 2000-1999; V-6 3.3 Eng.; Inlet (Upper)  
 Ply; Voyager; 1998; V-6 3.3 Eng.; Inlet (Upper); W/Front AC  
 Ply; Voyager; 1997; V-6 3.3 Eng.; Inlet (Upper); W/4-Spd Trans.  
 Ply; Voyager; 1999; V-6 3.8 Eng.; Inlet (Upper)  
 Ply; Voyager; 1998; V-6 3.8 (Canada) Eng.; Inlet (Upper); W/Front AC  
 Ply; Voyager; 1997; V-6 3.8 (Canada) Eng.; Inlet (Upper); W/4-Spd Trans.

## A61113

Jeep; Grand Cherokee; 1995-1994; 6-Cyl. 4.0 Eng.; Aux. Cooler Inlet Tube From Rad (Upper)

## A61114

Jeep; Grand Cherokee; 1993; V-8 5.2 Eng.; Inlet Tube From Rad (Lower)

## A61115

Dodge; Dakota; 1996-1994; V-6 3.9 Eng.; Rad Supply Tube To Aux. Cooler (Lower)  
 Dodge; Dakota; 1996-1994; V-8 5.2 Eng.; Rad Supply Tube To Aux. Cooler (Lower)

## A61118

Jeep; Grand Cherokee; 1997-1994; V-8 5.2 Eng.; Inlet Tube From Rad (Lower)

## A61121

Jeep; Cherokee; 1998-1994; 4-Cyl. 2.5 Eng.; Inlet Hose From Rad Tube (Upper)

## A61125

Jeep; Grand Cherokee; 1996; 6-Cyl. 4.0 Eng.; Aux. Cooler Inlet Tube From Rad (Upper)

## A61126

Jeep; Grand Cherokee; 1996; 6-Cyl. 4.0 Eng.; Aux. Cooler Outlet Tube (Lower)

## A61128

Jeep; Grand Cherokee; 1997-1993; V-8 5.2 Eng.; Aux. Cooler Outlet Tube (Lower)

## A61130

Dodge; Ram Pickup; 2001-1994; V-8 5.2 Eng.; Aux. Cooler Supply From Rad (Upper)

Dodge; Ram Pickup; 2002-1995; V-8 5.9 Eng.; Aux. Cooler Supply From Rad (Upper)

## A61131

Dodge; Dakota; 1999-1997; V-6 3.9 Eng.; Rad Supply Tube To Aux. Cooler (Lower)

Dodge; Dakota; 1999-1997; V-8 5.2 Eng.; Rad Supply Tube To Aux. Cooler (Lower)

Dodge; Dakota; 1999-1998; V-8 5.9 Eng.; Rad Supply Tube To Aux. Cooler (Lower)

Dodge; Durango; 1999-1998; V-8 5.2 Eng.; Rad Supply Tube To Aux. Cooler (Lower)

Dodge; Durango; 1999-1998; V-8 5.9 Eng.; Rad Supply Tube To Aux. Cooler (Lower)

## A61134

Buick; Skylark; 1995-1994; 4-Cyl. 2.3 Eng.; Outlet (Lower); W/4-Spd Trans.

Buick; Skylark; 1998-1996; 4-Cyl. 2.4 Eng.; Outlet (Lower)

Buick; Skylark; 1998-1994; V-6 3.1 Eng.; Outlet (Lower)

Chev; Beretta; 1994; 4-Cyl. 2.3 Eng.; Outlet (Lower); W/4-Spd Trans.

Chev; Beretta; 1996-1994; V-6 3.1 Eng.; Outlet (Lower)

Chev; Corsica; 1996-1994; V-6 3.1 Eng.; Outlet (Lower)

Olds; Achieva; 1995-1994; 4-Cyl. 2.3 Eng.; Outlet (Lower); W/4-Spd Trans.

Olds; Achieva; 1998-1997; 4-Cyl. 2.4 Eng.; Outlet (Lower)

Olds; Achieva; 1998-1997; V-6 3.1 Eng.; Outlet (Lower)

Olds; Achieva; 1995-1994; V-6 3.1 Eng.; Outlet (Lower)

Pont; Grand Am; 1995-1994; 4-Cyl. 2.3 Eng.; Outlet (Lower); W/4-Spd Trans.

Pont; Grand Am; 1998-1996; 4-Cyl. 2.4 Eng.; Outlet (Lower)

Pont; Grand Am; 1998-1994; V-6 3.1 Eng.; Outlet (Lower)

## A61136

Dodge; Dakota; 1996-1994; V-6 3.9 Eng.; Inlet Hose From Rad (Pass. Side); W/O Snow Plow Pkg

Dodge; Dakota; 1996-1994; V-8 5.2 Eng.; Inlet Hose From Rad (Pass. Side); W/O Snow Plow Pkg

Jeep; Wrangler; 1995-1994; 4-Cyl. 2.5 Eng.; Inlet Hose (Driver Side)

## A61139

Jeep; Cherokee; 2000-1999; 4-Cyl. 2.5 Eng.; Inlet Hose From Rad (Lower)

Jeep; Cherokee; 1998-1997; 4-Cyl. 2.5 Eng.; Aux. Cooler Inlet (Lower)

Jeep; Cherokee; 2001-1997; 6-Cyl. 4.0 Eng.; Aux. Cooler Inlet (Lower)

## A61140

Buick; Riviera; 1993-1991; V-6 3.8 Eng.; Outlet To Trans. (Upper)

Cad; Deville; 1995-1994; V-8 4.9 Eng.; Outlet To Trans. (Upper)

Cad; Eldorado; 1993-1991; V-8 4.9 Eng.; Outlet To Trans. (Upper)

Cad; Seville; 1993-1991; V-8 4.9 Eng.; Outlet To Trans. (Upper)

Olds; Toronado; 1992-1991; V-6 3.8 Eng.; Outlet To Trans. (Upper)

## A61142

Dodge; Ram Pickup; 1998-1997; 6-Cyl. 5.9 Diesel Eng.; Oil Cooler Inlet Hose To Tube (Front); W/O Sensor Port

Dodge; Ram Pickup; 1996-1994; 6-Cyl. 5.9 Diesel Eng.; Oil Cooler Inlet Hose To Tube (Front)

## Numerical Listing - Oil Cooler Assemblies & End Fittings

### A61145

Jeep; Grand Cherokee; 1995-1993; V-8 5.2 Eng.; Inlet Hose From Rad (Lower)

### A61149

Dodge; B Van; 2003-1998; V-6 3.9 Eng.; Inlet Hose From Rad (Pass. Side)

Dodge; B Van; 2003-1998; V-8 5.2 Eng.; Inlet Hose From Rad (Pass. Side)

Dodge; B Van; 2003-1998; V-8 5.9 Eng.; Inlet Hose From Rad (Pass. Side)

### A61150

Buick; Skyhawk; 1986-1985; 4-Cyl. 1.8 Eng.; Outlet (Lower)

Buick; Skyhawk; 1989-1985; 4-Cyl. 2.0 Eng.; Outlet (Lower)

Chev; Cavalier; 1989-1986; 4-Cyl. 2.0 Eng.; Outlet (Lower)

Chev; Cavalier; 1994-1990; 4-Cyl. 2.2 Eng.; Outlet (Lower)

Olds; Firenza; 1986-1985; 4-Cyl. 1.8 Eng.; Outlet (Lower)

Olds; Firenza; 1988-1985; 4-Cyl. 2.0 Eng.; Outlet (Lower)

Pont; Sunbird; 1986-1985; 4-Cyl. 1.8 Eng.; Outlet (Lower)

Pont; Sunbird; 1994-1985; 4-Cyl. 2.0 Eng.; Outlet (Lower)

### A61152

Dodge; Dakota; 1999-1997; V-6 3.9 Eng.; Inlet Hose From Rad (Pass. Side); W/4WD

Dodge; Dakota; 1999-1997; V-8 5.2 Eng.; Inlet Hose From Rad (Pass. Side); W/4WD

Dodge; Dakota; 2000; V-8 5.9 Eng.; Inlet Hose From Rad (Pass. Side)

Dodge; Dakota; 1999-1998; V-8 5.9 Eng.; Inlet Hose From Rad (Pass. Side); W/4WD

Dodge; Durango; 1999; V-6 3.9 Eng.; Inlet Hose From Rad (Pass. Side); W/4WD

Dodge; Durango; 1998; V-6 3.9 Eng.; Inlet Hose From Rad (Pass. Side)

Dodge; Durango; 1999; V-8 5.2 Eng.; Inlet Hose From Rad (Pass. Side); W/4WD

Dodge; Durango; 1998; V-8 5.2 Eng.; Inlet Hose From Rad (Pass. Side)

Dodge; Durango; 2000; V-8 5.9 Eng.; Inlet Hose From Rad (Pass. Side)

Dodge; Durango; 1999; V-8 5.9 Eng.; Inlet Hose From Rad (Pass. Side); W/4WD

Dodge; Durango; 1998; V-8 5.9 Eng.; Inlet Hose From Rad (Pass. Side)

### A61156

Dodge; Ram Pickup; 2001-1997; V-6 3.9 Eng.; Inlet Hose From Rad (Upper)

Dodge; Ram Pickup; 1996-1994; V-6 3.9 Eng.; Inlet Hose From Rad (Upper); W/42RH Trans.

Dodge; Ram Pickup; 2001; V-8 5.2 Eng.; Inlet Hose From Rad (Upper); W/O Aux. Cooler

Dodge; Ram Pickup; 2000; V-8 5.2 Eng.; Inlet Hose From Rad (Upper); W/Ext. Cab

Dodge; Ram Pickup; 2000; V-8 5.2 Eng.; Inlet Hose From Rad (Upper); W/Std. Cab; 1-17 & Newer

Dodge; Ram Pickup; 1999-1996; V-8 5.2 Eng.; Inlet Hose From Rad (Upper)

Dodge; Ram Pickup; 1995-1994; V-8 5.2 Eng.; Inlet Hose From Rad (Upper); W/O Sensor Port On Tube

Dodge; Ram Pickup; 2002; V-8 5.9 Eng.; Inlet Hose From Rad (Upper)

Dodge; Ram Pickup; 2001; V-8 5.9 Eng.; Inlet Hose From Rad (Upper); W/O Aux. Cooler

Dodge; Ram Pickup; 2000; V-8 5.9 Eng.; Inlet Hose From Rad (Upper); W/Ext. Cab

Dodge; Ram Pickup; 2000; V-8 5.9 Eng.; Inlet Hose From Rad (Upper); W/Std. Cab; 1-17 & Newer

Dodge; Ram Pickup; 1999-1996; V-8 5.9 Eng.; Inlet Hose From Rad (Upper)

Dodge; Ram Pickup; 1995-1994; V-8 5.9 Eng.; Inlet Hose From Rad (Upper); W/O Sensor Port On Tube

### A61158

Dodge; Ram Pickup; 2002-1994; V-10 8.0 Eng.; Inlet Hose From Rad (Upper)

### A61162

Dodge; Dakota; 2002-2000; V-6 3.9 Eng.; Inlet Hose From Rad (Pass. Side)

Dodge; Dakota; 1999-1997; V-6 3.9 Eng.; Inlet Hose From Rad (Pass. Side); W/2WD

Dodge; Dakota; 1999-1997; V-8 5.2 Eng.; Inlet Hose From Rad (Pass. Side); W/2WD

### A61162 - Continued

Dodge; Dakota; 2003-2001; V-8 5.9 Eng.; Inlet Hose From Rad (Pass. Side)

Dodge; Dakota; 1999-1998; V-8 5.9 Eng.; Inlet Hose From Rad (Pass. Side); W/2WD

Dodge; Durango; 1999; V-6 3.9 Eng.; Inlet Hose From Rad (Pass. Side); W/2WD

Dodge; Durango; 2000; V-8 5.2 Eng.; Inlet Hose From Rad (Pass. Side)

Dodge; Durango; 1999; V-8 5.2 Eng.; Inlet Hose From Rad (Pass. Side); W/2WD

Dodge; Durango; 2003-2001; V-8 5.9 Eng.; Inlet Hose From Rad (Pass. Side)

Dodge; Durango; 1999; V-8 5.9 Eng.; Inlet Hose From Rad (Pass. Side); W/2WD

### A61171

Dodge; B Van; 1997-1994; V-6 3.9 Eng.; Inlet Hose From Rad (Pass. Side)

Dodge; B Van; 1997-1994; V-8 5.2 Eng.; Inlet Hose From Rad (Pass. Side)

Dodge; B Van; 1997-1994; V-8 5.9 Eng.; Inlet Hose From Rad (Pass. Side)

### A61172

Chev; Blazer Full Size; 1994-1993; V-8 5.7 Eng.; Aux. Cooler Inlet (Pass. Side); W/17-Bolt Trans. Pan (MT1)

Chev; C&K Pickup; 1995-1993; V-8 5.7 Eng.; Aux. Cooler Inlet (Pass. Side); Exc 3500HD; W/17-Bolt Trans. Pan (MT1)

Chev; Suburban; 1995-1993; V-8 5.7 Eng.; Aux. Cooler Inlet (Pass. Side); W/17-Bolt Trans. Pan (MT1)

GMC; C&K Pickup; 1995-1993; V-8 5.7 Eng.; Aux. Cooler Inlet (Pass. Side); Exc 3500HD; W/17-Bolt Trans. Pan (MT1)

GMC; Suburban; 1995-1993; V-8 5.7 Eng.; Aux. Cooler Inlet (Pass. Side); W/17-Bolt Trans. Pan (MT1)

GMC; Yukon; 1995-1993; V-8 5.7 Eng.; Aux. Cooler Inlet (Pass. Side); W/17-Bolt Trans. Pan (MT1)

### A61174

Jeep; Grand Cherokee; 1997-1996; 6-Cyl. 4.0 Eng.; Inlet Hose From Rad (Upper)

### A61206

Jeep; Grand Cherokee; 1997-1996; V-8 5.2 Eng.; Inlet Hose From Rad (Lower)

### A61213

Chev; G Van; 1996; V-8 7.4 Eng.; Aux. Cooler Inlet Hose (Lower)

Chev; G Van; 1995-1994; V-8 7.4 Eng.; Aux. Cooler Inlet Hose From Rad (Lower)

GMC; G Van; 1996; V-8 7.4 Eng.; Aux. Cooler Inlet Hose (Lower)

GMC; G Van; 1995-1994; V-8 7.4 Eng.; Aux. Cooler Inlet Hose From Rad (Lower)

### A61217

Chev; Blazer Full Size; 1994-1993; V-8 5.7 Eng.; Aux. Cooler Inlet (Pass. Side); W/16-Bolt Trans. Pan (M30)

Chev; C&K Pickup; 1995-1993; V-8 5.7 Eng.; Aux. Cooler Inlet (Pass. Side); Exc 3500HD; W/16-Bolt Trans. Pan (M30)

Chev; Suburban; 1995-1993; V-8 5.7 Eng.; Aux. Cooler Inlet (Pass. Side); W/16-Bolt Trans. Pan (M30)

Chev; Tahoe; 1995; V-8 5.7 Eng.; Aux. Cooler Inlet (Pass. Side)

GMC; C&K Pickup; 1995-1993; V-8 5.7 Eng.; Aux. Cooler Inlet (Pass. Side); Exc 3500HD; W/16-Bolt Trans. Pan (M30)

GMC; Suburban; 1995-1993; V-8 5.7 Eng.; Aux. Cooler Inlet (Pass. Side); W/16-Bolt Trans. Pan (M30)

GMC; Yukon; 1995-1993; V-8 5.7 Eng.; Aux. Cooler Inlet (Pass. Side); W/16-Bolt Trans. Pan (M30)

### A61219

Chev; Blazer Full Size; 1994; V-8 6.5 Diesel Eng.; Aux. Cooler Inlet (Pass. Side)

Chev; C&K Pickup; 1995-1993; V-8 6.5 Diesel Eng.; Aux. Cooler Inlet (Pass. Side); W/17-Bolt Trans. Pan (MT1)

Chev; Suburban; 1995-1994; V-8 6.5 Diesel Eng.; Aux. Cooler Inlet (Pass. Side)

Chev; Tahoe; 1995; V-8 6.5 Diesel Eng.; Aux. Cooler Inlet (Pass. Side)

GMC; C&K Pickup; 1995-1993; V-8 6.5 Diesel Eng.; Aux. Cooler Inlet (Pass. Side); W/17-Bolt Trans. Pan (MT1)



# Numerical Listing - Oil Cooler Assemblies & End Fittings

## A61219 - Continued

GMC; Suburban; 1995-1994; V-8 6.5 Diesel Eng.; Aux. Cooler Inlet (Pass. Side)

## A61220

Chev; G Van; 1996; V-6 4.3 Eng.; Aux. Cooler Inlet Hose (Lower)  
 Chev; G Van; 1995-1994; V-6 4.3 Eng.; Aux. Cooler Inlet Hose From Rad (Lower); W/17-Bolt Trans. Pan (MT1)  
 Chev; G Van; 1995-1994; V-8 5.0 Eng.; Aux. Cooler Inlet Hose From Rad (Lower); W/17-Bolt Trans. Pan (MT1)  
 Chev; G Van; 1996; V-8 5.7 Eng.; Aux. Cooler Inlet Hose (Lower)  
 Chev; G Van; 1995-1994; V-8 5.7 Eng.; Aux. Cooler Inlet Hose From Rad (Lower); W/17-Bolt Trans. Pan (MT1)  
 Chev; G Van; 1996; V-8 6.5 Diesel Eng.; Aux. Cooler Inlet Hose (Lower)  
 Chev; G Van; 1995-1994; V-8 6.5 Diesel Eng.; Aux. Cooler Inlet Hose From Rad (Lower); W/17-Bolt Trans. Pan (MT1)  
 GMC; G Van; 1996; V-6 4.3 Eng.; Aux. Cooler Inlet Hose (Lower)  
 GMC; G Van; 1995-1994; V-6 4.3 Eng.; Aux. Cooler Inlet Hose From Rad (Lower); W/17-Bolt Trans. Pan (MT1)  
 GMC; G Van; 1995-1994; V-8 5.0 Eng.; Aux. Cooler Inlet Hose From Rad (Lower); W/17-Bolt Trans. Pan (MT1)  
 GMC; G Van; 1996; V-8 5.7 Eng.; Aux. Cooler Inlet Hose (Lower)  
 GMC; G Van; 1995-1994; V-8 5.7 Eng.; Aux. Cooler Inlet Hose From Rad (Lower); W/17-Bolt Trans. Pan (MT1)  
 GMC; G Van; 1996; V-8 6.5 Diesel Eng.; Aux. Cooler Inlet Hose (Lower)  
 GMC; G Van; 1995-1994; V-8 6.5 Diesel Eng.; Aux. Cooler Inlet Hose From Rad (Lower); W/17-Bolt Trans. Pan (MT1)

## A61221

Chev; Camaro; 1995-1993; V-6 3.4 Eng.; Inlet From Rad (Upper)  
 Chev; Camaro; 2002-1995; V-6 3.8 Eng.; Inlet From Rad (Upper)  
 Chev; Camaro; 2002-1993; V-8 5.7 Eng.; Inlet From Rad (Upper)  
 Pont; Firebird; 1995-1993; V-6 3.4 Eng.; Inlet From Rad (Upper)  
 Pont; Firebird; 2002-1995; V-6 3.8 Eng.; Inlet From Rad (Upper)  
 Pont; Firebird; 2002-1993; V-8 5.7 Eng.; Inlet From Rad (Upper)

## A61222

Buick; Skylark; 1989-1988; 4-Cyl. 2.3 Eng.; Outlet (Lower)  
 Buick; Skylark; 1988; V-6 3.0 Eng.; Outlet (Lower)  
 Buick; Skylark; 1989; V-6 3.3 Eng.; Outlet (Lower)  
 Olds; Cutlass Calais; 1989-1988; 4-Cyl. 2.3 Eng.; Outlet (Lower)  
 Olds; Cutlass Calais; 1988; V-6 3.0 Eng.; Outlet (Lower)  
 Olds; Cutlass Calais; 1989; V-6 3.3 Eng.; Outlet (Lower)  
 Pont; Grand Am; 1989-1988; 4-Cyl. 2.0 Eng.; Outlet (Lower)  
 Pont; Grand Am; 1989-1988; 4-Cyl. 2.3 Eng.; Outlet (Lower)

## A61223

Buick; Skylark; 1989-1988; 4-Cyl. 2.3 Eng.; Inlet (Upper)  
 Buick; Skylark; 1989-1988; 4-Cyl. 2.5 Eng.; Inlet (Upper)  
 Buick; Skylark; 1988; V-6 3.0 Eng.; Inlet (Upper)  
 Buick; Skylark; 1989; V-6 3.3 Eng.; Inlet (Upper)  
 Olds; Cutlass Calais; 1989-1988; 4-Cyl. 2.3 Eng.; Inlet (Upper)  
 Olds; Cutlass Calais; 1989-1988; 4-Cyl. 2.5 Eng.; Inlet (Upper)  
 Olds; Cutlass Calais; 1988; V-6 3.0 Eng.; Inlet (Upper)  
 Olds; Cutlass Calais; 1989; V-6 3.3 Eng.; Inlet (Upper)  
 Pont; Grand Am; 1989-1988; 4-Cyl. 2.0 Eng.; Inlet (Upper)  
 Pont; Grand Am; 1989-1988; 4-Cyl. 2.3 Eng.; Inlet (Upper)  
 Pont; Grand Am; 1989-1988; 4-Cyl. 2.5 Eng.; Inlet (Upper)

## A61224

Buick; Skylark; 1991-1990; 4-Cyl. 2.5 Eng.; Inlet (Upper)  
 Olds; Cutlass Calais; 1991-1990; 4-Cyl. 2.5 Eng.; Inlet (Upper)  
 Pont; Grand Am; 1991-1990; 4-Cyl. 2.5 Eng.; Inlet (Upper)

## A61225

Buick; Skylark; 1991-1990; 4-Cyl. 2.3 Eng.; Inlet (Upper)  
 Buick; Skylark; 1991-1990; V-6 3.3 Eng.; Inlet (Upper)  
 Olds; Cutlass Calais; 1991-1990; 4-Cyl. 2.3 Eng.; Inlet (Upper)  
 Olds; Cutlass Calais; 1991-1990; V-6 3.3 Eng.; Inlet (Upper)  
 Pont; Grand Am; 1991-1990; 4-Cyl. 2.3 Eng.; Inlet (Upper)

## A61226

Buick; Skylark; 1991-1990; 4-Cyl. 2.3 Eng.; Outlet (Lower)  
 Buick; Skylark; 1991-1990; V-6 3.3 Eng.; Outlet (Lower)  
 Olds; Cutlass Calais; 1991-1990; 4-Cyl. 2.3 Eng.; Outlet (Lower)  
 Olds; Cutlass Calais; 1991-1990; V-6 3.3 Eng.; Outlet (Lower)  
 Pont; Grand Am; 1991-1990; 4-Cyl. 2.3 Eng.; Outlet (Lower)

## A61227

Buick; Skylark; 1993-1992; 4-Cyl. 2.3 Eng.; Outlet (Lower)  
 Buick; Skylark; 1993-1992; V-6 3.3 Eng.; Outlet (Lower)  
 Chev; Beretta; 1993-1992; 4-Cyl. 2.2 Eng.; Outlet (Lower)  
 Chev; Beretta; 1993-1992; V-6 3.1 Eng.; Outlet (Lower)  
 Chev; Corsica; 1993-1992; 4-Cyl. 2.2 Eng.; Outlet (Lower)  
 Chev; Corsica; 1993-1992; V-6 3.1 Eng.; Outlet (Lower)  
 Olds; Achieva; 1993-1992; 4-Cyl. 2.3 Eng.; Outlet (Lower)  
 Olds; Achieva; 1993-1992; V-6 3.3 Eng.; Outlet (Lower)  
 Pont; Grand Am; 1993-1992; 4-Cyl. 2.3 Eng.; Outlet (Lower)  
 Pont; Grand Am; 1993-1992; V-6 3.3 Eng.; Outlet (Lower)

## A61228

Buick; Skylark; 1993-1992; 4-Cyl. 2.3 Eng.; Inlet (Upper)  
 Buick; Skylark; 1993-1992; V-6 3.3 Eng.; Inlet (Upper)  
 Olds; Achieva; 1993-1992; 4-Cyl. 2.3 Eng.; Inlet (Upper)  
 Olds; Achieva; 1993-1992; V-6 3.3 Eng.; Inlet (Upper)  
 Pont; Grand Am; 1993-1992; 4-Cyl. 2.3 Eng.; Inlet (Upper)  
 Pont; Grand Am; 1993-1992; V-6 3.3 Eng.; Inlet (Upper)

## A61229

Chev; Beretta; 1993-1992; 4-Cyl. 2.2 Eng.; Inlet (Upper)  
 Chev; Beretta; 1993-1992; V-6 3.1 Eng.; Inlet (Upper)  
 Chev; Corsica; 1993-1992; 4-Cyl. 2.2 Eng.; Inlet (Upper)  
 Chev; Corsica; 1993-1992; V-6 3.1 Eng.; Inlet (Upper)

## A61230

Buick; Skyhawk; 1986-1985; 4-Cyl. 1.8 Eng.; Inlet (Upper)  
 Buick; Skyhawk; 1989-1985; 4-Cyl. 2.0 Eng.; Inlet (Upper)  
 Chev; Cavalier; 1989-1986; 4-Cyl. 2.0 Eng.; Inlet (Upper)  
 Chev; Cavalier; 1994-1990; 4-Cyl. 2.2 Eng.; Inlet (Upper)  
 Olds; Firenza; 1986-1985; 4-Cyl. 1.8 Eng.; Inlet (Upper)  
 Olds; Firenza; 1988-1985; 4-Cyl. 2.0 Eng.; Inlet (Upper)  
 Pont; Sunbird; 1986-1985; 4-Cyl. 1.8 Eng.; Inlet (Upper)  
 Pont; Sunbird; 1994-1985; 4-Cyl. 2.0 Eng.; Inlet (Upper)

## A61231

Buick; Skylark; 1987-1985; 4-Cyl. 2.5 Eng.; Inlet (Upper)  
 Buick; Skylark; 1985; V-6 2.8 Eng.; Inlet (Upper)  
 Buick; Skylark; 1987-1986; V-6 3.0 Eng.; Inlet (Upper)  
 Buick; Somerset; 1987-1986; 4-Cyl. 2.5 Eng.; Inlet (Upper)  
 Buick; Somerset; 1987-1986; V-6 3.0 Eng.; Inlet (Upper)  
 Buick; Somerset Regal; 1985; 4-Cyl. 2.5 Eng.; Inlet (Upper)  
 Buick; Somerset Regal; 1985; V-6 3.0 Eng.; Inlet (Upper)  
 Cad; Cimarron; 1988-1985; V-6 2.8 Eng.; Inlet (Upper)  
 Chev; Cavalier; 1989-1985; V-6 2.8 Eng.; Inlet (Upper)  
 Chev; Cavalier; 1994-1990; V-6 3.1 Eng.; Inlet (Upper)  
 Olds; Firenza; 1987-1985; V-6 2.8 Eng.; Inlet (Upper)  
 Pont; Sunbird; 1994-1991; V-6 3.1 Eng.; Inlet (Upper)

## A61236

Chev; Lumina; 1999-1995; V-6 3.1 Eng.; Aux. Cooler Outlet (Lower)  
 Chev; Lumina; 1997-1995; V-6 3.4 Eng.; Aux. Cooler Outlet (Lower)  
 Chev; Lumina; 1999-1998; V-6 3.8 Eng.; Aux. Cooler Outlet (Lower)  
 Chev; Monte Carlo; 1999-1995; V-6 3.1 Eng.; Aux. Cooler Outlet (Lower)  
 Chev; Monte Carlo; 1997-1995; V-6 3.4 Eng.; Aux. Cooler Outlet (Lower)  
 Chev; Monte Carlo; 1999-1998; V-6 3.8 Eng.; Aux. Cooler Outlet (Lower)  
 Olds; Intrigue; 1998; V-6 3.8 Eng.; Aux. Cooler Outlet (Lower)  
 Pont; Grand Prix; 1999-1998; V-6 3.1 Eng.; Aux. Cooler Outlet (Lower)  
 Pont; Grand Prix; 1999-1998; V-6 3.8 Eng.; Aux. Cooler Outlet (Lower)

## A61243

Buick; Lesabre; 1993-1991; V-6 3.8 Eng.; Outlet To Trans. (Upper)  
 Buick; Park Ave.; 1993-1991; V-6 3.8 Eng.; Outlet To Trans. (Upper)  
 Cad; Deville; 1993-1991; V-8 4.9 Eng.; Outlet To Trans. (Upper)  
 Cad; Fleetwood; 1992-1991; V-8 4.9 Eng.; Outlet To Trans. (Upper)  
 Cad; Sixty Special; 1993; V-8 4.9 Eng.; Outlet To Trans. (Upper)  
 Olds; Eighty Eight; 1993-1991; V-6 3.8 Eng.; Outlet To Trans. (Upper)  
 Olds; Ninety Eight; 1992-1991; V-6 3.8 Eng.; Outlet To Trans. (Upper)  
 Pont; Bonneville; 1993-1991; V-6 3.8 Eng.; Outlet To Trans. (Upper)

## A61246

Chev; Beretta; 1989-1987; 4-Cyl. 2.0 Eng.; Inlet (Upper); W/3-Spd Trans.  
 Chev; Beretta; 1991-1990; 4-Cyl. 2.2 Eng.; Inlet (Upper); W/3-Spd Trans.  
 Chev; Beretta; 1989-1987; V-6 2.8 Eng.; Inlet (Upper); W/3-Spd Trans.  
 Chev; Beretta; 1991-1990; V-6 3.1 Eng.; Inlet (Upper); W/3-Spd Trans.  
 Chev; Corsica; 1989-1987; 4-Cyl. 2.0 Eng.; Inlet (Upper)

# Numerical Listing - Oil Cooler Assemblies & End Fittings

## A61246 - Continued

Chev; Corsica; 1991-1990; 4-Cyl. 2.2 Eng.; Inlet (Upper)  
Chev; Corsica; 1989-1987; V-6 2.8 Eng.; Inlet (Upper)  
Chev; Corsica; 1991-1990; V-6 3.1 Eng.; Inlet (Upper)

## A61247

Chev; Beretta; 1989-1987; 4-Cyl. 2.0 Eng.; Outlet (Lower); W/3-Spd Trans.  
Chev; Beretta; 1991-1990; 4-Cyl. 2.2 Eng.; Outlet (Lower); W/3-Spd Trans.  
Chev; Beretta; 1989-1987; V-6 2.8 Eng.; Outlet (Lower); W/3-Spd Trans.  
Chev; Beretta; 1991-1990; V-6 3.1 Eng.; Outlet (Lower); W/3-Spd Trans.  
Chev; Corsica; 1989-1987; 4-Cyl. 2.0 Eng.; Outlet (Lower)  
Chev; Corsica; 1991-1990; 4-Cyl. 2.2 Eng.; Outlet (Lower)  
Chev; Corsica; 1989-1987; V-6 2.8 Eng.; Outlet (Lower)  
Chev; Corsica; 1991-1990; V-6 3.1 Eng.; Outlet (Lower)

## A61248

Buick; Skylark; 1991-1988; 4-Cyl. 2.5 Eng.; Outlet (Lower)  
Buick; Somerset; 1987-1986; 4-Cyl. 2.5 Eng.; Outlet (Lower)  
Buick; Somerset Regal; 1985; 4-Cyl. 2.5 Eng.; Outlet (Lower)  
Olds; Cutlass Calais; 1991-1988; 4-Cyl. 2.5 Eng.; Outlet (Lower)  
Pont; Grand Am; 1991-1988; 4-Cyl. 2.5 Eng.; Outlet (Lower)

## A61249

Buick; Skylark; 1987-1985; 4-Cyl. 2.5 Eng.; Outlet (Lower)  
Buick; Skylark; 1985; V-6 2.8 Eng.; Outlet (Lower)  
Buick; Skylark; 1987-1986; V-6 3.0 Eng.; Outlet (Lower)  
Buick; Somerset; 1987-1986; V-6 3.0 Eng.; Outlet (Lower)  
Buick; Somerset Regal; 1985; V-6 3.0 Eng.; Outlet (Lower)  
Cad; Cimarron; 1988-1985; V-6 2.8 Eng.; Outlet (Lower)  
Chev; Cavalier; 1989-1985; V-6 2.8 Eng.; Outlet (Lower)  
Chev; Cavalier; 1994-1990; V-6 3.1 Eng.; Outlet (Lower)  
Olds; Firenza; 1987-1985; V-6 2.8 Eng.; Outlet (Lower)  
Pont; Sunbird; 1994-1991; V-6 3.1 Eng.; Outlet (Lower)

## A61271

Buick; Lesabre; 1995-1991; V-6 3.8 Eng.; Aux. Cooler Supply From Rad (Upper)  
Buick; Park Ave.; 1996-1991; V-6 3.8 Eng.; Aux. Cooler Supply From Rad (Upper)  
Cad; Deville; 1993-1991; V-8 4.9 Eng.; Aux. Cooler Supply From Rad (Upper)  
Cad; Fleetwood; 1992-1991; V-8 4.9 Eng.; Aux. Cooler Supply From Rad (Upper)  
Cad; Sixty Special; 1993; V-8 4.9 Eng.; Aux. Cooler Supply From Rad (Upper)  
Olds; Eighty Eight; 1996-1991; V-6 3.8 Eng.; Aux. Cooler Outlet Tube (Upper)  
Olds; Ninety Eight; 1995-1991; V-6 3.8 Eng.; Aux. Cooler Outlet Tube (Upper)  
Pont; Bonneville; 1996-1991; V-6 3.8 Eng.; Aux. Cooler Outlet Tube (Upper)

## A61274

Buick; Lesabre; 1992-1991; V-6 3.8 Eng.; Inlet To Trans. (Lower)  
Buick; Park Ave.; 1993-1991; V-6 3.8 Eng.; Inlet To Trans. (Lower)  
Cad; Deville; 1993-1991; V-8 4.9 Eng.; Inlet To Trans. (Lower)  
Cad; Fleetwood; 1992-1991; V-8 4.9 Eng.; Inlet To Trans. (Lower)  
Cad; Sixty Special; 1993; V-8 4.9 Eng.; Inlet To Trans. (Lower)  
Olds; Eighty Eight; 1993; V-6 3.8 Eng.; Inlet To Trans. (Lower); W/O Aux. Cooler  
Olds; Eighty Eight; 1991; V-6 3.8 Eng.; Inlet To Trans. (Lower); W/O Aux. Cooler  
Olds; Ninety Eight; 1993-1991; V-6 3.8 Eng.; Inlet To Trans. (Lower); W/O Aux. Cooler  
Pont; Bonneville; 1993-1991; V-6 3.8 Eng.; Inlet To Trans. (Lower); W/O Aux. Cooler

## A61276

Ford; Excursion; 2001; V-8 5.4 Eng.; Aux. Cooler Inlet (Driver Side); 2-24 & Older  
Ford; Excursion; 2000; V-8 5.4 Eng.; Aux. Cooler Inlet (Driver Side)  
Ford; Excursion; 2001; V-8 7.3 Diesel Eng.; Aux. Cooler Inlet (Driver Side); 2-24 & Older  
Ford; Excursion; 2000; V-8 7.3 Diesel Eng.; Aux. Cooler Inlet (Driver Side)  
Ford; Excursion; 2001; V-10 6.8 Eng.; Aux. Cooler Inlet (Driver Side); 2-24 & Older  
Ford; Excursion; 2000; V-10 6.8 Eng.; Aux. Cooler Inlet (Driver Side)  
Ford; Super Duty Pickup; 2001; V-8 5.4 Eng.; Aux. Cooler Inlet (Driver Side); 2-24 & Older

## A61276 - Continued

Ford; Super Duty Pickup; 2000-1999; V-8 5.4 Eng.; Aux. Cooler Inlet (Driver Side)  
Ford; Super Duty Pickup; 2001; V-8 7.3 Diesel Eng.; Aux. Cooler Inlet (Driver Side); 2-24 & Older  
Ford; Super Duty Pickup; 2000-1999; V-8 7.3 Diesel Eng.; Aux. Cooler Inlet (Driver Side)  
Ford; Super Duty Pickup; 2001; V-10 6.8 Eng.; Aux. Cooler Inlet (Driver Side); 2-24 & Older  
Ford; Super Duty Pickup; 2000-1999; V-10 6.8 Eng.; Aux. Cooler Inlet (Driver Side)

## A61298

Buick; Century; 1996-1994; V-6 3.1 Eng.; Inlet Hose To Trans. (Upper)  
Olds; Cutlass Ciera; 1996-1994; V-6 3.1 Eng.; Inlet To Trans. (Upper)  
Olds; Cutlass Cruiser; 1994; V-6 3.1 Eng.; Inlet To Trans. (Upper)

## A61299

Buick; Century; 1996-1994; V-6 3.1 Eng.; Outlet Hose To Trans. (Lower)  
Olds; Cutlass Ciera; 1996-1994; V-6 3.1 Eng.; Outlet To Trans. (Lower)  
Olds; Cutlass Cruiser; 1994; V-6 3.1 Eng.; Outlet To Trans. (Lower)

## A61300

Cad; Allante; 1993; V-8 4.6 Eng.; Outlet From Rad (Lower)  
Cad; Deville; 1999-1994; V-8 4.6 Eng.; Outlet From Rad (Lower)  
Cad; Eldorado; 2002; V-8 4.6 Eng.; Outlet From Rad (Lower); 1st Design; W/Threaded Fitting  
Cad; Eldorado; 2001-1994; V-8 4.6 Eng.; Outlet From Rad (Lower)  
Cad; Seville; 1999-1993; V-8 4.6 Eng.; Outlet From Rad (Lower)

## A61314

Chev; Express; 2002-1996; V-6 4.3 Eng.; Aux. Cooler Inlet (Upper); W/17-Bolt Trans. Pan (MT1)  
Chev; Express; 2002-1996; V-8 5.7 Eng.; Aux. Cooler Inlet (Upper); W/17-Bolt Trans. Pan (MT1)  
Chev; G Van; 1998-1997; V-6 4.3 Eng.; Aux. Cooler Inlet (Upper); W/17-Bolt Trans. Pan (MT1)  
Chev; G Van; 1998-1997; V-8 5.7 Eng.; Aux. Cooler Inlet (Upper); W/17-Bolt Trans. Pan (MT1)  
GMC; Savana; 2002-1996; V-6 4.3 Eng.; Aux. Cooler Inlet (Upper); W/17-Bolt Trans. Pan (MT1)  
GMC; Savana; 2002-1996; V-8 5.7 Eng.; Aux. Cooler Inlet (Pass. Side); W/17-Bolt Trans. Pan (MT1)

## A63000

Buick; Century; 1993; 4-Cyl. 2.2 Eng.; Tube To Tube (Lower); Cut-to-fit  
Buick; Century; 1993; 4-Cyl. 2.2 Eng.; Tube To Tube (Upper); Cut-to-fit  
Buick; Century; 1992-1990; 4-Cyl. 2.5 Eng.; Tube To Tube (Lower); Cut-to-fit  
Buick; Century; 1992-1990; 4-Cyl. 2.5 Eng.; Tube To Tube (Upper); Cut-to-fit  
Buick; Century; 1989-1988; 4-Cyl. 2.5 Eng.; Inlet Hose (Upper); Cut-to-fit  
Buick; Century; 1989-1988; 4-Cyl. 2.5 Eng.; Outlet Hose (Lower); Cut-to-fit  
Buick; Century; 1989-1988; V-6 2.8 Eng.; Inlet Hose (Upper); Cut-to-fit  
Buick; Century; 1989-1988; V-6 2.8 Eng.; Outlet Hose (Lower); Cut-to-fit  
Buick; Century; 1993-1990; V-6 3.3 Eng.; Tube To Tube (Lower); Cut-to-fit  
Buick; Century; 1993-1990; V-6 3.3 Eng.; Tube To Tube (Upper); Cut-to-fit  
Buick; Century; 1989; V-6 3.3 Eng.; Inlet Hose (Upper); Cut-to-fit  
Buick; Century; 1989; V-6 3.3 Eng.; Outlet Hose (Lower); Cut-to-fit  
Buick; Century; 1988; V-6 3.8 Eng.; Inlet Hose (Upper); Cut-to-fit  
Buick; Century; 1988; V-6 3.8 Eng.; Outlet Hose (Lower); Cut-to-fit  
Buick; Electra; 1990-1988; V-6 3.8 Eng.; Tube To Tube (Lower); Cut-to-fit  
Buick; Electra; 1990-1988; V-6 3.8 Eng.; Tube To Tube (Upper); Cut-to-fit  
Buick; Lesabre; 1990-1988; V-6 3.8 Eng.; Inlet Hose From Rad (Upper); W/O Aux. Cooler; Cut-to-fit  
Buick; Reatta; 1990-1988; V-6 3.8 Eng.; Inlet Hose (Upper)  
Buick; Reatta; 1990-1988; V-6 3.8 Eng.; Outlet Hose (Lower)  
Buick; Regal; 1989-1988; V-6 2.8 Eng.; Outlet Hose To Trans. (Lower); Cut-to-fit  
Buick; Regal; 1991; V-6 3.1 Eng.; Inlet Hose To Trans. (Upper); W/5/16" Tubing; Cut-to-fit  
Buick; Regal; 1991; V-6 3.1 Eng.; Outlet Hose To Trans. (Lower); W/5/16" ID Hose; Cut-to-fit  
Buick; Regal; 1990-1989; V-6 3.1 Eng.; Outlet Hose To Trans. (Lower); Cut-to-fit  
Buick; Riviera; 1990; V-6 3.8 Eng.; Aux. Cooler Outlet Hose (Upper); Cut-to-fit  
Buick; Riviera; 1990; V-6 3.8 Eng.; Inlet Hose From Rad To Trans. (Lower); Cut-to-fit

## Numerical Listing - Oil Cooler Assemblies & End Fittings

### A63000 - Continued

Buick; Riviera; 1990; V-6 3.8 Eng.; Outlet Hose From Rad (Upper) To Aux. Cooler (Lower); Cut-to-fit  
 Buick; Riviera; 1990; V-6 3.8 Eng.; Outlet Hose To Trans. (Upper); Cut-to-fit  
 Buick; Riviera; 1989-1986; V-6 3.8 Eng.; Inlet Hose (Lower); Cut-to-fit  
 Buick; Riviera; 1989-1986; V-6 3.8 Eng.; Outlet Hose (Upper); Cut-to-fit  
 Cad; Eldorado; 1990; V-8 4.5 Eng.; Aux. Cooler Outlet Tube (Upper); Cut-to-fit  
 Cad; Eldorado; 1990; V-8 4.5 Eng.; Inlet Tube From Rad To Trans. (Lower); Cut-to-fit  
 Cad; Eldorado; 1990; V-8 4.5 Eng.; Outlet Tube From Rad (Upper) To Aux. Cooler (Lower); Cut-to-fit  
 Cad; Eldorado; 1990; V-8 4.5 Eng.; Outlet Tube To Trans. (Upper); Cut-to-fit  
 Cad; Seville; 1990; V-8 4.5 Eng.; Aux. Cooler Outlet Hose (Upper); Cut-to-fit  
 Cad; Seville; 1990; V-8 4.5 Eng.; Inlet Hose From Rad To Trans. (Lower); Cut-to-fit  
 Cad; Seville; 1990; V-8 4.5 Eng.; Outlet Hose From Rad (Upper) To Aux. Cooler (Lower); Cut-to-fit  
 Cad; Seville; 1990; V-8 4.5 Eng.; Outlet Hose To Trans. (Upper); Cut-to-fit  
 Chev; Camaro; 1995-1993; V-6 3.4 Eng.; Outlet Hose From Rad (Lower); Cut-to-fit  
 Chev; Camaro; 1997-1995; V-6 3.8 Eng.; Outlet Hose From Rad (Lower); Cut-to-fit  
 Chev; Camaro; 1997-1993; V-8 5.7 Eng.; Outlet Hose From Rad (Lower); Cut-to-fit  
 Chev; Celebrity; 1990-1985; 4-Cyl. 2.5 Eng.; Inlet Hose (Upper); Cut-to-fit  
 Chev; Celebrity; 1990-1985; 4-Cyl. 2.5 Eng.; Outlet Hose (Lower); Cut-to-fit  
 Chev; Celebrity; 1989-1985; V-6 2.8 Eng.; Inlet Hose (Upper); Cut-to-fit  
 Chev; Celebrity; 1989-1985; V-6 2.8 Eng.; Outlet Hose (Lower); Cut-to-fit  
 Chev; Celebrity; 1990; V-6 3.1 Eng.; Inlet Hose (Upper); Cut-to-fit  
 Chev; Celebrity; 1990; V-6 3.1 Eng.; Outlet Hose (Lower); Cut-to-fit  
 Chev; Lumina; 1992-1990; 4-Cyl. 2.5 Eng.; Inlet Hose To Trans. (Upper); Cut-to-fit  
 Chev; Lumina; 1992-1990; 4-Cyl. 2.5 Eng.; Outlet Hose To Trans. (Lower); Cut-to-fit  
 Chev; Lumina; 1993-1990; V-6 3.1 Eng.; Inlet Hose To Trans. (Upper); W/3-Spd Trans.; Cut-to-fit  
 Chev; Lumina; 1993-1991; V-6 3.1 Eng.; Outlet Hose To Trans. (Lower); W/3-Spd Trans.; Cut-to-fit  
 Chev; Lumina; 1990; V-6 3.1 Eng.; Outlet Hose To Trans. (Lower); Cut-to-fit  
 Chry; Fifth Ave.; 1989-1984; V-8 5.2 Eng.; Inlet; Cut-to-fit  
 Chry; Fifth Ave.; 1989-1984; V-8 5.2 Eng.; Outlet; Cut-to-fit  
 Chry; Lebaron; 1990; 4-Cyl. 2.2 Eng.; Aux. Cooler Inlet Hose; Cut-to-fit  
 Chry; Lebaron; 1990; 4-Cyl. 2.2 Eng.; Aux. Cooler Outlet Hose; Cut-to-fit  
 Chry; Lebaron; 1994-1990; 4-Cyl. 2.5 Eng.; Aux. Cooler Inlet Hose; Cut-to-fit  
 Chry; Lebaron; 1994-1990; 4-Cyl. 2.5 Eng.; Aux. Cooler Outlet Hose; Cut-to-fit  
 Chry; Lebaron; 1995-1990; V-6 3.0 Eng.; Aux. Cooler Inlet Hose; Cut-to-fit  
 Chry; Lebaron; 1995-1990; V-6 3.0 Eng.; Aux. Cooler Outlet Hose; Cut-to-fit  
 Chry; Sebring; 1999; 4-Cyl. 2.0 Eng.; Rad To Inlet Tube (Pass. Side); Convertible; Cut-to-fit  
 Chry; Sebring; 1999; 4-Cyl. 2.0 Eng.; Rad To Inlet Tube (Pass. Side); Coupe; W/O Calif Emiss; Cut-to-fit  
 Chry; Sebring; 2000-1999; V-6 2.5 Eng.; Rad To Inlet Tube (Pass. Side); Coupe; W/O Calif Emiss; Cut-to-fit  
 Chry; Town & Country Van; 1992; V-6 3.3 Eng.; Inlet Hose; W/Air Cooled Trans. Cooler; W/AWD; Cut-to-fit  
 Chry; Town & Country Van; 1992; V-6 3.3 Eng.; Outlet Hose; W/Air Cooled Trans. Cooler; W/AWD; Cut-to-fit  
 Chry; Voyager; 2003; 4-Cyl. 2.4 Eng.; Aux. Cooler Inlet Hose (Upper); Cut-to-fit  
 Chry; Voyager; 2003; 4-Cyl. 2.4 Eng.; Aux. Cooler Outlet Hose (Lower); Cut-to-fit  
 Chry; Voyager; 2003-2001; V-6 3.3 Eng.; Aux. Cooler Inlet Hose (Upper); Cut-to-fit  
 Chry; Voyager; 2003-2001; V-6 3.3 Eng.; Aux. Cooler Outlet Hose (Lower); Cut-to-fit  
 Dodge; Avenger; 1999; 4-Cyl. 2.0 Eng.; Rad To Inlet Tube (Pass. Side); W/O Calif Emiss; Cut-to-fit  
 Dodge; Avenger; 2000-1999; V-6 2.5 Eng.; Rad To Inlet Tube (Pass. Side); W/O Calif Emiss; Cut-to-fit  
 Dodge; B Van; 1993-1990; V-6 3.9 Eng.; Aux. Cooler Hose; Cut-to-fit  
 Dodge; B Van; 1989-1988; V-6 3.9 Eng.; Inlet Tube; Cut-to-fit  
 Dodge; B Van; 1989-1988; V-6 3.9 Eng.; Outlet Tube; Cut-to-fit  
 Dodge; B Van; 1993-1990; V-8 5.2 Eng.; Aux. Cooler Hose; Cut-to-fit  
 Dodge; B Van; 1989-1984; V-8 5.2 Eng.; Inlet Tube; Cut-to-fit  
 Dodge; B Van; 1989-1984; V-8 5.2 Eng.; Outlet Tube; Cut-to-fit  
 Dodge; B Van; 1993-1990; V-8 5.9 Eng.; Aux. Cooler Hose; Cut-to-fit

### A63000 - Continued

Dodge; B Van; 1989-1984; V-8 5.9 Eng.; Inlet Tube; Cut-to-fit  
 Dodge; B Van; 1989-1984; V-8 5.9 Eng.; Outlet Tube; Cut-to-fit  
 Dodge; Caravan; 1991; V-6 3.0 Eng.; Inlet Hose; W/Air Cooled Trans. Cooler; W/AWD; Cut-to-fit  
 Dodge; Caravan; 1991; V-6 3.0 Eng.; Outlet Hose; W/Air Cooled Trans. Cooler; W/AWD; Cut-to-fit  
 Dodge; Caravan; 2002-2001; V-6 3.3 Eng.; Aux. Cooler Inlet (Upper); Cut-to-fit  
 Dodge; Caravan; 2002-2001; V-6 3.3 Eng.; Aux. Cooler Outlet (Lower); Cut-to-fit  
 Dodge; Caravan; 1992-1991; V-6 3.3 Eng.; Inlet Hose; W/Air Cooled Trans. Cooler; W/AWD; Cut-to-fit  
 Dodge; Caravan; 1992-1991; V-6 3.3 Eng.; Outlet Hose; W/Air Cooled Trans. Cooler; W/AWD; Cut-to-fit  
 Dodge; D & W Pickup; 1987-1982; 6-Cyl. 3.7 Eng.; Inlet Hose (Pass. Side); Cut-to-fit  
 Dodge; D & W Pickup; 1987-1982; 6-Cyl. 3.7 Eng.; Outlet Hose (Driver Side); Cut-to-fit  
 Dodge; D & W Pickup; 1989-1988; V-6 3.9 Eng.; Inlet Hose (Pass. Side); Cut-to-fit  
 Dodge; D & W Pickup; 1989-1988; V-6 3.9 Eng.; Outlet Hose (Driver Side); Cut-to-fit  
 Dodge; D & W Pickup; 1989-1982; V-8 5.2 Eng.; Inlet Hose (Pass. Side); Cut-to-fit  
 Dodge; D & W Pickup; 1989-1982; V-8 5.2 Eng.; Outlet Hose (Driver Side); Cut-to-fit  
 Dodge; D & W Pickup; 1989-1982; V-8 5.9 Eng.; Inlet Hose (Pass. Side); Cut-to-fit  
 Dodge; D & W Pickup; 1989-1982; V-8 5.9 Eng.; Outlet Hose (Driver Side); Cut-to-fit  
 Dodge; Dakota; 1989-1987; V-6 3.9 Eng.; Inlet Hose (Pass. Side); Cut-to-fit  
 Dodge; Dakota; 1989-1987; V-6 3.9 Eng.; Outlet Hose (Driver Side); Cut-to-fit  
 Dodge; Dakota; 1989; V-8 5.2 Eng.; Inlet Hose (Pass. Side); Cut-to-fit  
 Dodge; Dakota; 1989; V-8 5.2 Eng.; Outlet Hose (Driver Side); Cut-to-fit  
 Dodge; Daytona; 1992; 4-Cyl. 2.2 Eng.; Aux. Cooler Inlet; Cut-to-fit  
 Dodge; Daytona; 1992; 4-Cyl. 2.2 Eng.; Aux. Cooler Outlet; Cut-to-fit  
 Dodge; Daytona; 1990; 4-Cyl. 2.2 Eng.; Aux. Cooler Inlet; Cut-to-fit  
 Dodge; Daytona; 1990; 4-Cyl. 2.2 Eng.; Aux. Cooler Outlet; Cut-to-fit  
 Dodge; Daytona; 1993-1990; 4-Cyl. 2.5 Eng.; Aux. Cooler Inlet; Cut-to-fit  
 Dodge; Daytona; 1993-1990; 4-Cyl. 2.5 Eng.; Aux. Cooler Outlet; Cut-to-fit  
 Dodge; Daytona; 1993-1990; V-6 3.0 Eng.; Aux. Cooler Inlet; Cut-to-fit  
 Dodge; Daytona; 1993-1990; V-6 3.0 Eng.; Aux. Cooler Outlet; Cut-to-fit  
 Dodge; Diplomat; 1989-1984; V-8 5.2 Eng.; Inlet; Cut-to-fit  
 Dodge; Diplomat; 1989-1984; V-8 5.2 Eng.; Outlet; Cut-to-fit  
 Dodge; Grand Caravan; 2002-2001; V-6 3.3 Eng.; Aux. Cooler Inlet (Upper); Cut-to-fit  
 Dodge; Grand Caravan; 2002-2001; V-6 3.3 Eng.; Aux. Cooler Outlet (Lower); Cut-to-fit  
 Dodge; Grand Caravan; 1992-1991; V-6 3.3 Eng.; Inlet Hose; W/Air Cooled Trans. Cooler; W/AWD; Cut-to-fit  
 Dodge; Grand Caravan; 1992-1991; V-6 3.3 Eng.; Outlet Hose; W/Air Cooled Trans. Cooler; W/AWD; Cut-to-fit  
 Dodge; Grand Caravan; 2002-2001; V-6 3.8 Eng.; Aux. Cooler Inlet (Upper); Cut-to-fit  
 Dodge; Grand Caravan; 2002-2001; V-6 3.8 Eng.; Aux. Cooler Outlet (Lower); Cut-to-fit  
 Dodge; Ramcharger; 1989-1984; V-8 5.2 Eng.; Inlet Hose (Pass. Side); Cut-to-fit  
 Dodge; Ramcharger; 1989-1984; V-8 5.2 Eng.; Outlet Hose (Driver Side); Cut-to-fit  
 Dodge; Ramcharger; 1989-1984; V-8 5.9 Eng.; Inlet Hose (Pass. Side); Cut-to-fit  
 Dodge; Ramcharger; 1989-1984; V-8 5.9 Eng.; Outlet Hose (Driver Side); Cut-to-fit  
 Eagle; Talon; 1994-1993; 4-Cyl. 1.8 Eng.; Inlet Hose; Cut-to-fit  
 Eagle; Talon; 1994-1993; 4-Cyl. 1.8 Eng.; Outlet Hose; Cut-to-fit  
 Eagle; Talon; 1998-1995; 4-Cyl. 2.0 Eng.; Tube To Tube; W/O Turbo; Cut-to-fit  
 Eagle; Talon; 1994-1990; 4-Cyl. 2.0 Eng.; Inlet Hose; W/O Turbo; Cut-to-fit  
 Eagle; Talon; 1994-1990; 4-Cyl. 2.0 Eng.; Outlet Hose; W/O Turbo; Cut-to-fit  
 Ford; Bronco; 1992-1991; 6-Cyl. 4.9 Eng.; Inlet Hose; Cut-to-fit  
 Ford; Bronco; 1992-1991; 6-Cyl. 4.9 Eng.; Outlet Hose; Cut-to-fit  
 Ford; Bronco; 1996-1991; V-8 5.0 Eng.; Inlet Hose; Cut-to-fit  
 Ford; Bronco; 1996-1991; V-8 5.0 Eng.; Outlet Hose; Cut-to-fit  
 Ford; Bronco; 1996-1991; V-8 5.8 Eng.; Inlet Hose; Cut-to-fit  
 Ford; Bronco; 1996-1991; V-8 5.8 Eng.; Outlet Hose; Cut-to-fit  
 Ford; Bronco Full Size; 1990-1988; 6-Cyl. 4.9 Eng.; Inlet Hose; Cut-to-fit  
 Ford; Bronco Full Size; 1990-1988; 6-Cyl. 4.9 Eng.; Outlet Hose; Cut-to-fit  
 Ford; Bronco Full Size; 1990-1988; V-8 5.0 Eng.; Inlet Hose; Cut-to-fit  
 Ford; Bronco Full Size; 1990-1988; V-8 5.0 Eng.; Outlet Hose; Cut-to-fit

# Numerical Listing - Oil Cooler Assemblies & End Fittings

## A63000 - Continued

Ford; Bronco Full Size; 1990-1988; V-8 5.8 Eng.; Inlet Hose; Cut-to-fit  
 Ford; Bronco Full Size; 1990-1988; V-8 5.8 Eng.; Outlet Hose; Cut-to-fit  
 Ford; Country Squire; 1991-1988; V-8 5.0 Eng.; Inlet Hose; Cut-to-fit  
 Ford; Country Squire; 1991-1988; V-8 5.0 Eng.; Outlet Hose; Cut-to-fit  
 Ford; Crown Victoria; 2003-2000; V-8 4.6 Eng.; Aux. Cooler Hose; Cut-to-fit  
 Ford; Crown Victoria; 1995-1992; V-8 4.6 Eng.; Inlet Hose; Cut-to-fit  
 Ford; Crown Victoria; 1995-1992; V-8 4.6 Eng.; Outlet Hose; Cut-to-fit  
 Ford; E Van; 1996-1988; 6-Cyl. 4.9 Eng.; Inlet Hose; Cut-to-fit  
 Ford; E Van; 1996-1988; 6-Cyl. 4.9 Eng.; Outlet Hose; Cut-to-fit  
 Ford; E Van; 2003-1997; V-6 4.2 Eng.; Aux. Cooler Inlet Hose (Driver Side); Cut-to-fit  
 Ford; E Van; 2003-1997; V-6 4.2 Eng.; Aux. Cooler Outlet Hose (Pass. Side); Cut-to-fit  
 Ford; E Van; 2005-1997; V-8 4.6 Eng.; Aux. Cooler Inlet Hose (Driver Side); Cut-to-fit  
 Ford; E Van; 2003-1997; V-8 4.6 Eng.; Aux. Cooler Outlet Hose (Pass. Side); Cut-to-fit  
 Ford; E Van; 1996-1988; V-8 5.0 Eng.; Inlet Hose; Cut-to-fit  
 Ford; E Van; 1996-1988; V-8 5.0 Eng.; Outlet Hose; Cut-to-fit  
 Ford; E Van; 2005-2004; V-8 5.4 Eng.; Aux. Cooler Inlet Hose (Driver Side); Cut-to-fit  
 Ford; E Van; 1996-1988; V-8 5.8 Eng.; Inlet Hose; Cut-to-fit  
 Ford; E Van; 1996-1988; V-8 5.8 Eng.; Outlet Hose; Cut-to-fit  
 Ford; E Van; 1996-1988; V-8 7.3 Diesel Eng.; Inlet Hose; Cut-to-fit  
 Ford; E Van; 1996-1988; V-8 7.3 Diesel Eng.; Outlet Hose; Cut-to-fit  
 Ford; E Van; 1996-1988; V-8 7.5 Eng.; Inlet Hose; Cut-to-fit  
 Ford; E Van; 1996-1988; V-8 7.5 Eng.; Outlet Hose; Cut-to-fit  
 Ford; Escort; 1995-1991; 4-Cyl. 1.8 Eng.; Outlet Hose; Cut-to-fit  
 Ford; Escort; 1995-1988; 4-Cyl. 1.9 Eng.; Outlet Hose; Cut-to-fit  
 Ford; Escort; 1990-1988; 4-Cyl. 1.9 Eng.; Inlet Hose; Cut-to-fit  
 Ford; Escort; 2002-1997; 4-Cyl. 2.0 Eng.; Outlet Hose; Cut-to-fit  
 Ford; Expedition; 1998-1997; V-8 4.6 Eng.; Aux. Cooler Inlet Hose (Pass. Side); Cut-to-fit  
 Ford; F Pickup; 1996-1990; 6-Cyl. 4.9 Eng.; Aux. Cooler Hose; Cut-to-fit  
 Ford; F Pickup; 1996-1990; 6-Cyl. 4.9 Eng.; Inlet Hose; Cut-to-fit  
 Ford; F Pickup; 1996-1990; 6-Cyl. 4.9 Eng.; Outlet Hose; Cut-to-fit  
 Ford; F Pickup; 1998-1997; V-6 4.2 Eng.; Aux. Cooler Inlet Hose (Pass. Side); Cut-to-fit  
 Ford; F Pickup; 1998-1997; V-8 4.6 Eng.; Aux. Cooler Inlet Hose (Pass. Side); Cut-to-fit  
 Ford; F Pickup; 1996-1990; V-8 5.0 Eng.; Aux. Cooler Hose; Cut-to-fit  
 Ford; F Pickup; 1996-1990; V-8 5.0 Eng.; Inlet Hose; Cut-to-fit  
 Ford; F Pickup; 1996-1990; V-8 5.0 Eng.; Outlet Hose; Cut-to-fit  
 Ford; F Pickup; 1998-1997; V-8 5.4 Eng.; Aux. Cooler Inlet Hose (Pass. Side); W/4R70W Trans.; Cut-to-fit  
 Ford; F Pickup; 1996-1990; V-8 5.8 Eng.; Aux. Cooler Hose; Cut-to-fit  
 Ford; F Pickup; 1996-1990; V-8 5.8 Eng.; Inlet Hose; Cut-to-fit  
 Ford; F Pickup; 1996-1990; V-8 5.8 Eng.; Outlet Hose; Cut-to-fit  
 Ford; F Pickup; 1996-1990; V-8 7.3 Diesel Eng.; Aux. Cooler Hose; Cut-to-fit  
 Ford; F Pickup; 1996-1990; V-8 7.3 Diesel Eng.; Inlet Hose; Cut-to-fit  
 Ford; F Pickup; 1996-1990; V-8 7.5 Eng.; Aux. Cooler Hose; Cut-to-fit  
 Ford; F Pickup; 1996-1990; V-8 7.5 Eng.; Inlet Hose; Cut-to-fit  
 Ford; F Pickup; 1996-1990; V-8 7.5 Eng.; Outlet Hose; Cut-to-fit  
 Ford; Ltd Crown Victoria; 1991-1988; V-8 5.0 Eng.; Inlet Hose; Cut-to-fit  
 Ford; Ltd Crown Victoria; 1991-1988; V-8 5.0 Eng.; Outlet Hose; Cut-to-fit  
 Ford; Ltd Crown Victoria; 1991-1988; V-8 5.8 Eng.; Inlet Hose; Cut-to-fit  
 Ford; Ltd Crown Victoria; 1991-1988; V-8 5.8 Eng.; Outlet Hose; Cut-to-fit  
 Ford; Mustang; 1993; 4-Cyl. 2.3 Eng.; Inlet Hose; W/AOD Trans; Cut-to-fit  
 Ford; Mustang; 1993; 4-Cyl. 2.3 Eng.; Outlet Hose; W/AOD Trans; Cut-to-fit  
 Ford; Mustang; 1992-1990; 4-Cyl. 2.3 Eng.; Inlet Hose; W/AOD Trans.; Cut-to-fit  
 Ford; Mustang; 1992-1990; 4-Cyl. 2.3 Eng.; Outlet Hose; W/AOD Trans.; Cut-to-fit  
 Ford; Mustang; 1989-1988; 4-Cyl. 2.3 Eng.; Inlet Hose; W/AOD Trans.; Cut-to-fit  
 Ford; Mustang; 1989-1988; 4-Cyl. 2.3 Eng.; Outlet Hose; W/AOD Trans.; Cut-to-fit  
 Ford; Mustang; 2000-1994; V-6 3.8 Eng.; Aux. Cooler Inlet Hose; Cut-to-fit  
 Ford; Mustang; 2000-1994; V-6 3.8 Eng.; Aux. Cooler Outlet Hose; Cut-to-fit  
 Ford; Mustang; 1996-1994; V-6 3.8 Eng.; Inlet Hose; Cut-to-fit  
 Ford; Mustang; 1996-1994; V-6 3.8 Eng.; Outlet Hose; Cut-to-fit  
 Ford; Mustang; 2000-1997; V-8 4.6 Eng.; Aux. Cooler Inlet Hose; Cut-to-fit  
 Ford; Mustang; 2000-1997; V-8 4.6 Eng.; Aux. Cooler Outlet Hose; Cut-to-fit  
 Ford; Mustang; 1995-1994; V-8 5.0 Eng.; Aux. Cooler Inlet Hose; Cut-to-fit  
 Ford; Mustang; 1995-1994; V-8 5.0 Eng.; Aux. Cooler Outlet Hose; Cut-to-fit  
 Ford; Mustang; 1995-1994; V-8 5.0 Eng.; Inlet Hose; Cut-to-fit

## A63000 - Continued

Ford; Mustang; 1995-1994; V-8 5.0 Eng.; Outlet Hose; Cut-to-fit  
 Ford; Mustang; 1993; V-8 5.0 Eng.; Inlet Hose; W/AOD Trans; Cut-to-fit  
 Ford; Mustang; 1993; V-8 5.0 Eng.; Outlet Hose; W/AOD Trans; Cut-to-fit  
 Ford; Mustang; 1992-1990; V-8 5.0 Eng.; Inlet Hose; W/AOD Trans.; Cut-to-fit  
 Ford; Mustang; 1992-1990; V-8 5.0 Eng.; Outlet Hose; W/AOD Trans.; Cut-to-fit  
 Ford; Mustang; 1989; V-8 5.0 Eng.; Inlet Hose; W/AOD Trans; Cut-to-fit  
 Ford; Mustang; 1989; V-8 5.0 Eng.; Outlet Hose; W/AOD Trans; Cut-to-fit  
 Ford; Mustang; 1995; V-8 5.8 Eng.; Aux. Cooler Inlet Hose; Cut-to-fit  
 Ford; Mustang; 1995; V-8 5.8 Eng.; Aux. Cooler Outlet Hose; Cut-to-fit  
 Ford; Mustang; 1995; V-8 5.8 Eng.; Inlet Hose; Cut-to-fit  
 Ford; Mustang; 1995; V-8 5.8 Eng.; Outlet Hose; Cut-to-fit  
 Ford; Super Duty Van; 2003-2001; V-6 4.2 Eng.; Aux. Cooler Inlet Hose (Driver Side); Cut-to-fit  
 Ford; Super Duty Van; 2003-2001; V-6 4.2 Eng.; Aux. Cooler Outlet Hose (Pass. Side); Cut-to-fit  
 Ford; Super Duty Van; 2004-2003; V-8 4.6 Eng.; Aux. Cooler Inlet Hose (Driver Side); Cut-to-fit  
 Ford; Super Duty Van; 2003; V-8 4.6 Eng.; Aux. Cooler Outlet Hose (Pass. Side); Cut-to-fit  
 Ford; Super Duty Van; 2005-2004; V-8 5.4 Eng.; Aux. Cooler Inlet Hose (Driver Side); Cut-to-fit  
 Ford; Taurus; 1991-1986; 4-Cyl. 2.5 Eng.; Inlet Hose (Upper); Cut-to-fit  
 Ford; Taurus; 1991-1990; 4-Cyl. 2.5 Eng.; Outlet Hose (Lower); Cut-to-fit  
 Ford; Taurus; 1989-1986; 4-Cyl. 2.5 Eng.; Outlet Hose (Lower); W/ATX Trans.; Cut-to-fit  
 Ford; Taurus; 1995-1993; V-6 3.0 Eng.; Aux. Cooler Supply Hose; Cut-to-fit  
 Ford; Taurus; 1989-1986; V-6 3.0 Eng.; Inlet Hose (Upper); Cut-to-fit  
 Ford; Taurus; 1989-1986; V-6 3.0 Eng.; Outlet Hose (Lower); W/ATX Trans.; Cut-to-fit  
 Ford; Taurus; 1995-1990; V-6 3.8 Eng.; Aux. Cooler Supply Hose; W/Police Pkg; Cut-to-fit  
 Ford; Taurus; 1989-1988; V-6 3.8 Eng.; Inlet Hose (Upper); Cut-to-fit  
 Ford; Taurus; 1989-1988; V-6 3.8 Eng.; Outlet Hose (Lower); W/ATX Trans.; Cut-to-fit  
 Ford; Tempo; 1994-1988; 4-Cyl. 2.3 Eng.; Inlet Hose (Upper); Cut-to-fit  
 Ford; Tempo; 1994-1992; V-6 3.0 Eng.; Inlet Hose (Upper); Cut-to-fit  
 Ford; Tempo; 1994-1992; V-6 3.0 Eng.; Outlet Hose (Lower); Cut-to-fit  
 Ford; Thunderbird; 1988; 4-Cyl. 2.3 Eng.; Inlet Hose; Cut-to-fit  
 Ford; Thunderbird; 1988; 4-Cyl. 2.3 Eng.; Outlet Hose; Cut-to-fit  
 Ford; Thunderbird; 1993-1990; V-6 3.8 Eng.; Aux. Cooler Hose; W/5/16" ID Hose; Cut-to-fit  
 Ford; Thunderbird; 1989; V-6 3.8 Eng.; Inlet Hose (Upper); Cut-to-fit  
 Ford; Thunderbird; 1989; V-6 3.8 Eng.; Outlet Hose (Lower); Cut-to-fit  
 Ford; Thunderbird; 1988; V-6 3.8 Eng.; Inlet Hose; Cut-to-fit  
 Ford; Thunderbird; 1988; V-6 3.8 Eng.; Outlet Hose; Cut-to-fit  
 Ford; Thunderbird; 1995-1994; V-8 4.6 Eng.; Inlet Hose (Upper); Cut-to-fit  
 Ford; Thunderbird; 1995-1994; V-8 4.6 Eng.; Outlet Hose (Lower); Cut-to-fit  
 Ford; Thunderbird; 1993-1991; V-8 5.0 Eng.; Aux. Cooler Hose; W/5/16" ID Hose; Cut-to-fit  
 Ford; Thunderbird; 1988; V-8 5.0 Eng.; Inlet Hose; Cut-to-fit  
 Ford; Thunderbird; 1988; V-8 5.0 Eng.; Outlet Hose; Cut-to-fit  
 Ford; ZX2; 2003; 4-Cyl. 2.0 Eng.; Outlet Hose; Cut-to-fit  
 Jeep; Grand Cherokee; 2003-1999; 6-Cyl. 4.0 Eng.; Inlet Hose From Rad (Upper); Cut-to-fit  
 Jeep; Grand Cherokee; 2003-1999; 6-Cyl. 4.0 Eng.; Outlet Hose From Rad (Lower); Cut-to-fit  
 Jeep; Grand Cherokee; 2003-1999; V-8 4.7 Eng.; Inlet Hose From Rad (Lower); Cut-to-fit  
 Jeep; Grand Cherokee; 2003-1999; V-8 4.7 Eng.; Outlet Hose From Rad (Upper); Cut-to-fit  
 Jeep; Grand Wagoneer; 1991-1987; V-8 5.9 Eng.; Inlet Hose From Rad; Cut-to-fit  
 Jeep; Grand Wagoneer; 1991-1987; V-8 5.9 Eng.; Outlet Hose From Rad; Cut-to-fit  
 Jeep; J Pickup; 1987; 6-Cyl. 4.2 Eng.; Inlet Hose From Rad; Cut-to-fit  
 Jeep; J Pickup; 1987; 6-Cyl. 4.2 Eng.; Outlet Hose From Rad; Cut-to-fit  
 Jeep; J Pickup; 1988-1987; V-8 5.9 Eng.; Inlet Hose From Rad; Cut-to-fit  
 Jeep; J Pickup; 1988-1987; V-8 5.9 Eng.; Outlet Hose From Rad; Cut-to-fit  
 Jeep; Wrangler; 1993-1991; 4-Cyl. 2.5 Eng.; Inlet Hose; Cut-to-fit  
 Jeep; Wrangler; 1993-1991; 4-Cyl. 2.5 Eng.; Outlet Hose; Cut-to-fit  
 Jeep; Wrangler; 1990-1987; 4-Cyl. 2.5 Eng.; Inlet Hose (Driver Side); Cut-to-fit  
 Jeep; Wrangler; 1990-1987; 4-Cyl. 2.5 Eng.; Outlet Hose (Pass. Side); Cut-to-fit  
 Jeep; Wrangler; 1993-1991; 6-Cyl. 4.0 Eng.; Inlet Hose; Cut-to-fit  
 Jeep; Wrangler; 1993-1991; 6-Cyl. 4.0 Eng.; Outlet Hose; Cut-to-fit  
 Jeep; Wrangler; 1990-1987; 6-Cyl. 4.2 Eng.; Inlet Hose (Driver Side); Cut-to-fit

## Numerical Listing - Oil Cooler Assemblies & End Fittings

### A63000 - Continued

Jeep; Wrangler; 1990-1987; 6-Cyl. 4.2 Eng.; Outlet Hose (Pass. Side); Cut-to-fit  
 Linc; Continental; 1989-1988; V-6 3.8 Eng.; Inlet Hose; Cut-to-fit  
 Linc; Continental; 1989-1988; V-6 3.8 Eng.; Outlet Hose; Cut-to-fit  
 Linc; Mark VII; 1992-1988; V-8 5.0 Eng.; Inlet Hose; Cut-to-fit  
 Linc; Mark VII; 1992-1988; V-8 5.0 Eng.; Outlet Hose; Cut-to-fit  
 Linc; Mark VIII; 1995-1993; V-8 4.6 Eng.; Inlet Hose; Cut-to-fit  
 Linc; Mark VIII; 1995-1993; V-8 4.6 Eng.; Outlet Hose; Cut-to-fit  
 Linc; Town Car; 2003-2000; V-8 4.6 Eng.; Aux. Cooler Hose; Cut-to-fit  
 Linc; Town Car; 1995-1991; V-8 4.6 Eng.; Inlet Hose; Cut-to-fit  
 Linc; Town Car; 1995-1991; V-8 4.6 Eng.; Outlet Hose; Cut-to-fit  
 Linc; Town Car; 1990-1988; V-8 5.0 Eng.; Inlet Hose; Cut-to-fit  
 Linc; Town Car; 1990-1988; V-8 5.0 Eng.; Outlet Hose; Cut-to-fit  
 Merc; Capri; 1994-1991; 4-Cyl. 1.6 Eng.; Inlet Hose; Cut-to-fit  
 Merc; Capri; 1994-1991; 4-Cyl. 1.6 Eng.; Outlet Hose; Cut-to-fit  
 Merc; Colony Park; 1991-1988; V-8 5.0 Eng.; Inlet Hose; Cut-to-fit  
 Merc; Colony Park; 1991-1988; V-8 5.0 Eng.; Outlet Hose; Cut-to-fit  
 Merc; Cougar; 1993-1990; V-6 3.8 Eng.; Aux. Cooler Hose; W/5/16" ID Hose; Cut-to-fit  
 Merc; Cougar; 1989; V-6 3.8 Eng.; Inlet Hose (Upper); Cut-to-fit  
 Merc; Cougar; 1989; V-6 3.8 Eng.; Outlet Hose (Lower); Cut-to-fit  
 Merc; Cougar; 1988; V-6 3.8 Eng.; Inlet Hose; Cut-to-fit  
 Merc; Cougar; 1988; V-6 3.8 Eng.; Outlet Hose; Cut-to-fit  
 Merc; Cougar; 1995-1994; V-8 4.6 Eng.; Inlet Hose (Upper); Cut-to-fit  
 Merc; Cougar; 1995-1994; V-8 4.6 Eng.; Outlet Hose (Lower); Cut-to-fit  
 Merc; Cougar; 1993-1991; V-8 5.0 Eng.; Aux. Cooler Hose; W/5/16" ID Hose; Cut-to-fit  
 Merc; Cougar; 1988; V-8 5.0 Eng.; Inlet Hose; Cut-to-fit  
 Merc; Cougar; 1988; V-8 5.0 Eng.; Outlet Hose; Cut-to-fit  
 Merc; Grand Marquis; 2003-2000; V-8 4.6 Eng.; Aux. Cooler Hose; Cut-to-fit  
 Merc; Grand Marquis; 1995-1992; V-8 4.6 Eng.; Inlet Hose; Cut-to-fit  
 Merc; Grand Marquis; 1995-1992; V-8 4.6 Eng.; Outlet Hose; Cut-to-fit  
 Merc; Grand Marquis; 1991-1988; V-8 5.0 Eng.; Inlet Hose; Cut-to-fit  
 Merc; Grand Marquis; 1991-1988; V-8 5.0 Eng.; Outlet Hose; Cut-to-fit  
 Merc; Grand Marquis; 1989-1988; V-8 5.8 (Canada) Eng.; Inlet Hose; Cut-to-fit  
 Merc; Grand Marquis; 1989-1988; V-8 5.8 (Canada) Eng.; Outlet Hose; Cut-to-fit  
 Merc; Sable; 1986; 4-Cyl. 2.5 Eng.; Inlet Hose (Upper); Cut-to-fit  
 Merc; Sable; 1986; 4-Cyl. 2.5 Eng.; Outlet Hose (Lower); W/ATX Trans.; Cut-to-fit  
 Merc; Sable; 1995-1993; V-6 3.0 Eng.; Aux. Cooler Supply Hose; Cut-to-fit  
 Merc; Sable; 1989-1986; V-6 3.0 Eng.; Inlet Hose (Upper); Cut-to-fit  
 Merc; Sable; 1989-1986; V-6 3.0 Eng.; Outlet Hose (Lower); W/ATX Trans.; Cut-to-fit  
 Merc; Sable; 1995-1990; V-6 3.8 Eng.; Aux. Cooler Supply Hose; W/Police Pkg; Cut-to-fit  
 Merc; Sable; 1989-1988; V-6 3.8 Eng.; Inlet Hose (Upper); Cut-to-fit  
 Merc; Sable; 1989-1988; V-6 3.8 Eng.; Outlet Hose (Lower); W/ATX Trans.; Cut-to-fit  
 Merc; Topaz; 1994-1988; 4-Cyl. 2.3 Eng.; Inlet Hose (Upper); Cut-to-fit  
 Merc; Topaz; 1994-1992; V-6 3.0 Eng.; Inlet Hose (Upper); Cut-to-fit  
 Merc; Topaz; 1994-1992; V-6 3.0 Eng.; Outlet Hose (Lower); Cut-to-fit  
 Merc; Tracer; 1989-1988; 4-Cyl. 1.6 Eng.; Inlet Hose; Cut-to-fit  
 Merc; Tracer; 1989-1988; 4-Cyl. 1.6 Eng.; Outlet Hose; Cut-to-fit  
 Merc; Tracer; 1996-1991; 4-Cyl. 1.8 Eng.; Inlet Hose; Cut-to-fit  
 Merc; Tracer; 1996-1991; 4-Cyl. 1.9 Eng.; Outlet Hose; Cut-to-fit  
 Merc; Tracer; 1999-1997; 4-Cyl. 2.0 Eng.; Inlet Hose; Cut-to-fit  
 Olds; Cutlass Ciera; 1996-1993; 4-Cyl. 2.2 Eng.; Inlet Hose (Upper); Cut-to-fit  
 Olds; Cutlass Ciera; 1996-1993; 4-Cyl. 2.2 Eng.; Outlet Hose (Lower); Cut-to-fit  
 Olds; Cutlass Ciera; 1992-1988; 4-Cyl. 2.5 Eng.; Inlet Hose (Upper); Cut-to-fit  
 Olds; Cutlass Ciera; 1992-1988; 4-Cyl. 2.5 Eng.; Outlet Hose (Lower); Cut-to-fit  
 Olds; Cutlass Ciera; 1989-1988; V-6 2.8 Eng.; Inlet Hose (Upper); Cut-to-fit  
 Olds; Cutlass Ciera; 1989-1988; V-6 2.8 Eng.; Outlet Hose (Lower); Cut-to-fit  
 Olds; Cutlass Ciera; 1993-1989; V-6 3.3 Eng.; Inlet Hose (Upper); Cut-to-fit  
 Olds; Cutlass Ciera; 1993-1989; V-6 3.3 Eng.; Outlet Hose (Lower); Cut-to-fit  
 Olds; Cutlass Ciera; 1988; V-6 3.8 Eng.; Inlet Hose (Upper); Cut-to-fit  
 Olds; Cutlass Ciera; 1988; V-6 3.8 Eng.; Outlet Hose (Lower); Cut-to-fit  
 Olds; Cutlass Cruiser; 1990; 4-Cyl. 2.5 Eng.; Inlet Hose (Upper); Cut-to-fit  
 Olds; Cutlass Cruiser; 1990; 4-Cyl. 2.5 Eng.; Outlet Hose (Lower); Cut-to-fit  
 Olds; Cutlass Cruiser; 1993-1990; V-6 3.3 Eng.; Inlet Hose (Upper); Cut-to-fit

### A63000 - Continued

Olds; Cutlass Cruiser; 1993-1990; V-6 3.3 Eng.; Outlet Hose (Lower); Cut-to-fit  
 Olds; Cutlass Supreme; 1991-1990; 4-Cyl. 2.3 Eng.; Inlet Hose (Upper); Cut-to-fit  
 Olds; Cutlass Supreme; 1991-1990; 4-Cyl. 2.3 Eng.; Outlet Hose (Lower); Cut-to-fit  
 Olds; Cutlass Supreme; 1989-1988; V-6 2.8 Eng.; Inlet Hose (Upper); Cut-to-fit  
 Olds; Cutlass Supreme; 1989-1988; V-6 2.8 Eng.; Outlet Hose (Lower); Cut-to-fit  
 Olds; Cutlass Supreme; 1993-1991; V-6 3.1 Eng.; Inlet Hose (Upper); W/3-Spd Trans.; Cut-to-fit  
 Olds; Cutlass Supreme; 1993-1991; V-6 3.1 Eng.; Outlet Hose (Lower); W/3-Spd Trans.; Cut-to-fit  
 Olds; Cutlass Supreme; 1990-1989; V-6 3.1 Eng.; Inlet Hose (Upper); Cut-to-fit  
 Olds; Cutlass Supreme; 1990-1989; V-6 3.1 Eng.; Outlet Hose (Lower); Cut-to-fit  
 Olds; Cutlass Supreme; 1993-1991; V-6 3.4 Eng.; Inlet Hose (Upper); W/3-Spd Trans.; Cut-to-fit  
 Olds; Cutlass Supreme; 1993-1991; V-6 3.4 Eng.; Outlet Hose (Lower); W/3-Spd Trans.; Cut-to-fit  
 Olds; Cutlass Supreme; 1988; V-8 5.0 Eng.; Inlet Hose (Upper); Cut-to-fit  
 Olds; Cutlass Supreme; 1988; V-8 5.0 Eng.; Outlet Hose (Lower); Cut-to-fit  
 Olds; Delta 88; 1988; V-6 3.8 Eng.; Tube To Tube (Lower); Cut-to-fit  
 Olds; Delta 88; 1988; V-6 3.8 Eng.; Tube To Tube (Upper); Cut-to-fit  
 Olds; Eighty Eight; 1990-1989; V-6 3.8 Eng.; Inlet Hose From Rad (Upper); W/O Aux. Cooler; Cut-to-fit  
 Olds; Ninety Eight; 1990-1988; V-6 3.8 Eng.; Inlet Hose From Rad (Upper); W/O Aux. Cooler; Cut-to-fit  
 Olds; Toronado; 1990-1988; V-6 3.8 Eng.; Aux. Cooler Inlet Hose (Lower); Cut-to-fit  
 Olds; Toronado; 1990-1988; V-6 3.8 Eng.; Aux. Cooler Outlet Hose (Upper); Cut-to-fit  
 Olds; Toronado; 1990-1988; V-6 3.8 Eng.; Inlet (Lower); Cut-to-fit  
 Olds; Toronado; 1990-1988; V-6 3.8 Eng.; Outlet Hose (Upper); Cut-to-fit  
 Olds; Toronado; 1987-1986; V-6 3.8 Eng.; Inlet Hose (Lower); Cut-to-fit  
 Olds; Toronado; 1987-1986; V-6 3.8 Eng.; Outlet Hose (Lower); Cut-to-fit  
 Ply; Gran Fury; 1989-1984; V-8 5.2 Eng.; Inlet; Cut-to-fit  
 Ply; Gran Fury; 1989-1984; V-8 5.2 Eng.; Outlet; Cut-to-fit  
 Ply; Grand Voyager; 1992; V-6 3.3 Eng.; Inlet Hose; W/Air Cooled Trans. Cooler; W/AWD; Cut-to-fit  
 Ply; Grand Voyager; 1992; V-6 3.3 Eng.; Outlet Hose; W/Air Cooled Trans. Cooler; W/AWD; Cut-to-fit  
 Ply; Grand Voyager; 1991; V-6 3.3 Eng.; Inlet Hose; W/Air Cooled Trans. Cooler; Cut-to-fit  
 Ply; Grand Voyager; 1991; V-6 3.3 Eng.; Outlet (Lower); W/Water Cooled Trans. Cooler; Cut-to-fit  
 Ply; Grand Voyager; 1990; V-6 3.3 Eng.; Inlet Hose; Cut-to-fit  
 Ply; Grand Voyager; 1990; V-6 3.3 Eng.; Outlet Hose; Cut-to-fit  
 Ply; Laser; 1994-1991; 4-Cyl. 1.8 Eng.; Inlet Hose; Cut-to-fit  
 Ply; Laser; 1994-1991; 4-Cyl. 1.8 Eng.; Outlet Hose; Cut-to-fit  
 Ply; Laser; 1990; 4-Cyl. 1.8 Eng.; Inlet; Cut-to-fit  
 Ply; Laser; 1990; 4-Cyl. 1.8 Eng.; Outlet; Cut-to-fit  
 Ply; Laser; 1994-1991; 4-Cyl. 2.0 Eng.; Inlet; W/O Turbo; Cut-to-fit  
 Ply; Laser; 1994-1991; 4-Cyl. 2.0 Eng.; Outlet; W/O Turbo; Cut-to-fit  
 Ply; Laser; 1990; 4-Cyl. 2.0 Eng.; Inlet; Cut-to-fit  
 Ply; Laser; 1990; 4-Cyl. 2.0 Eng.; Outlet; Cut-to-fit  
 Ply; Voyager; 1991; 4-Cyl. 2.5 Eng.; Inlet Hose; W/Air Cooled Trans. Cooler; Cut-to-fit  
 Ply; Voyager; 1991; 4-Cyl. 2.5 Eng.; Outlet (Lower); W/Water Cooled Trans. Cooler; Cut-to-fit  
 Ply; Voyager; 1991-1990; V-6 3.0 Eng.; Inlet Hose; W/Air Cooled Trans. Cooler; Cut-to-fit  
 Ply; Voyager; 1991-1990; V-6 3.0 Eng.; Outlet Hose; W/Air Cooled Trans. Cooler; Cut-to-fit  
 Ply; Voyager; 1992; V-6 3.3 Eng.; Inlet Hose; W/Air Cooled Trans. Cooler; W/AWD; Cut-to-fit  
 Ply; Voyager; 1992; V-6 3.3 Eng.; Outlet Hose; W/Air Cooled Trans. Cooler; W/AWD; Cut-to-fit  
 Ply; Voyager; 1991; V-6 3.3 Eng.; Inlet Hose; W/Air Cooled Trans. Cooler; Cut-to-fit  
 Ply; Voyager; 1991; V-6 3.3 Eng.; Outlet (Lower); W/Water Cooled Trans. Cooler; Cut-to-fit  
 Pont; Firebird; 1995-1993; V-6 3.4 Eng.; Outlet Hose From Rad (Lower); Cut-to-fit  
 Pont; Firebird; 1997-1995; V-6 3.8 Eng.; Outlet Hose From Rad (Lower); Cut-to-fit  
 Pont; Firebird; 1997-1993; V-8 5.7 Eng.; Outlet Hose From Rad (Lower); Cut-to-fit  
 Pont; Grand Prix; 1991-1990; 4-Cyl. 2.3 Eng.; Inlet Hose (Upper); Cut-to-fit

## Numerical Listing - Oil Cooler Assemblies & End Fittings

### A63000 - Continued

Pont; Grand Prix; 1991-1990; 4-Cyl. 2.3 Eng.; Outlet Hose (Lower); Cut-to-fit  
 Pont; Grand Prix; 1989-1988; V-6 2.8 Eng.; Outlet Hose To Trans. (Lower); Cut-to-fit  
 Pont; Grand Prix; 1993-1992; V-6 3.1 Eng.; Inlet Hose To Trans. (Upper); W/3-Spd Trans.; Cut-to-fit  
 Pont; Grand Prix; 1993-1992; V-6 3.1 Eng.; Outlet Hose To Trans. (Lower); W/3-Spd Trans.; Cut-to-fit  
 Pont; Grand Prix; 1991; V-6 3.1 Eng.; Inlet Hose (Upper); W/3-Spd Trans.; Cut-to-fit  
 Pont; Grand Prix; 1991; V-6 3.1 Eng.; Outlet Hose (Lower); W/3-Spd Trans.; Cut-to-fit  
 Pont; Grand Prix; 1990-1989; V-6 3.1 Eng.; Inlet Hose To Trans. (Upper); W/Turbo; Cut-to-fit  
 Pont; Grand Prix; 1990-1989; V-6 3.1 Eng.; Outlet Hose To Trans. (Lower); W/O Turbo; Cut-to-fit  
 Pont; Grand Prix; 1991; V-6 3.4 Eng.; Inlet Hose (Upper); W/3-Spd Trans.; Cut-to-fit  
 Pont; Grand Prix; 1991; V-6 3.4 Eng.; Outlet Hose (Lower); W/3-Spd Trans.; Cut-to-fit  
 Pont; 6000; 1991-1985; 4-Cyl. 2.5 Eng.; Inlet Hose (Upper); Cut-to-fit  
 Pont; 6000; 1991-1985; 4-Cyl. 2.5 Eng.; Outlet Hose (Lower); Cut-to-fit  
 Pont; 6000; 1989-1985; V-6 2.8 Eng.; Inlet Hose (Upper); Cut-to-fit  
 Pont; 6000; 1989-1985; V-6 2.8 Eng.; Outlet Hose (Lower); Cut-to-fit  
 Pont; 6000; 1991-1988; V-6 3.1 Eng.; Inlet Hose (Upper); Cut-to-fit  
 Pont; 6000; 1991-1988; V-6 3.1 Eng.; Outlet Hose (Lower); Cut-to-fit

### A63001

Buick; Riviera; 1993-1991; V-6 3.8 Eng.; Aux. Cooler Outlet Hose (Upper); Cut-to-fit  
 Cad; Deville; 1995-1994; V-8 4.9 Eng.; Aux. Cooler Outlet Hose (Upper); Cut-to-fit  
 Cad; Eldorado; 1993-1991; V-8 4.9 Eng.; Aux. Cooler Outlet Hose (Upper); Cut-to-fit  
 Cad; Seville; 1993-1991; V-8 4.9 Eng.; Aux. Cooler Outlet Hose (Upper); Cut-to-fit  
 Chev; Lumina APV; 1995-1992; V-6 3.8 Eng.; Outlet To Trans. (Upper); W/Aux. Cooler; Cut-to-fit  
 Dodge; B Van; 1993-1990; V-6 3.9 Eng.; Inlet Hose; Cut-to-fit  
 Dodge; B Van; 1993-1990; V-6 3.9 Eng.; Outlet Hose; Cut-to-fit  
 Dodge; B Van; 1993-1990; V-8 5.2 Eng.; Inlet Hose; Cut-to-fit  
 Dodge; B Van; 1993-1990; V-8 5.2 Eng.; Outlet Hose; Cut-to-fit  
 Dodge; B Van; 1993-1990; V-8 5.9 Eng.; Inlet Hose; Cut-to-fit  
 Dodge; B Van; 1993-1990; V-8 5.9 Eng.; Outlet Hose; Cut-to-fit  
 Dodge; D & W Pickup; 1993-1990; V-6 3.9 Eng.; Inlet Hose (Pass. Side); Cut-to-fit  
 Dodge; D & W Pickup; 1993-1990; V-6 3.9 Eng.; Outlet Hose (Driver Side); Cut-to-fit  
 Dodge; D & W Pickup; 1993-1990; V-8 5.2 Eng.; Inlet Hose (Pass. Side); Cut-to-fit  
 Dodge; D & W Pickup; 1993-1990; V-8 5.2 Eng.; Outlet Hose (Driver Side); Cut-to-fit  
 Dodge; D & W Pickup; 1993-1990; V-8 5.9 Eng.; Inlet Hose (Pass. Side); Cut-to-fit  
 Dodge; D & W Pickup; 1993-1990; V-8 5.9 Eng.; Outlet Hose (Driver Side); Cut-to-fit  
 Dodge; Dakota; 1996-1994; V-6 3.9 Eng.; Aux. Cooler Hose; Cut-to-fit  
 Dodge; Dakota; 1993-1990; V-6 3.9 Eng.; Inlet Hose (Pass. Side); Cut-to-fit  
 Dodge; Dakota; 1993-1990; V-6 3.9 Eng.; Outlet Hose (Driver Side); Cut-to-fit  
 Dodge; Dakota; 1996-1994; V-8 5.2 Eng.; Aux. Cooler Hose; Cut-to-fit  
 Dodge; Dakota; 1993-1990; V-8 5.2 Eng.; Inlet Hose (Pass. Side); Cut-to-fit  
 Dodge; Dakota; 1993-1990; V-8 5.2 Eng.; Outlet Hose (Driver Side); Cut-to-fit  
 Dodge; Monaco; 1992-1990; V-6 3.0 Eng.; Inlet Hose From Rad (Upper); Cut-to-fit  
 Dodge; Ramcharger; 1993-1990; V-8 5.2 Eng.; Inlet Hose (Pass. Side); Cut-to-fit  
 Dodge; Ramcharger; 1993-1990; V-8 5.2 Eng.; Outlet Hose (Driver Side); Cut-to-fit  
 Dodge; Ramcharger; 1993-1990; V-8 5.9 Eng.; Inlet Hose (Pass. Side); Cut-to-fit  
 Dodge; Ramcharger; 1993-1990; V-8 5.9 Eng.; Outlet Hose (Driver Side); Cut-to-fit  
 Eagle; Premier; 1992-1988; V-6 3.0 Eng.; Inlet Hose From Rad (Upper); Cut-to-fit  
 Ford; Aerostar; 1997-1987; V-6 3.0 Eng.; Inlet Hose; Cut-to-fit  
 Ford; Aerostar; 1997-1987; V-6 3.0 Eng.; Outlet Hose; Cut-to-fit  
 Ford; Aerostar; 1997-1990; V-6 4.0 Eng.; Inlet Hose; Cut-to-fit  
 Ford; Aerostar; 1997-1990; V-6 4.0 Eng.; Outlet Hose; Cut-to-fit  
 Ford; Bronco Compact; 1990-1988; V-6 2.9 Eng.; Inlet Hose; Cut-to-fit

### A63001 - Continued

Ford; Bronco Compact; 1990-1988; V-6 2.9 Eng.; Outlet Hose; Cut-to-fit  
 Ford; E Van; 2003-1997; V-8 5.4 Eng.; Aux. Cooler Inlet Hose (Driver Side); Cut-to-fit  
 Ford; E Van; 2003-1997; V-8 5.4 Eng.; Aux. Cooler Outlet Hose (Pass. Side); Cut-to-fit  
 Ford; E Van; 1998-1997; V-8 7.3 Diesel Eng.; Aux. Cooler Inlet Hose (Driver Side); Cut-to-fit  
 Ford; E Van; 1998-1997; V-8 7.3 Diesel Eng.; Aux. Cooler Outlet Hose (Pass. Side); Cut-to-fit  
 Ford; E Van; 1998-1997; V-10 6.8 Eng.; Aux. Cooler Inlet Hose (Driver Side); Cut-to-fit  
 Ford; E Van; 1998-1997; V-10 6.8 Eng.; Aux. Cooler Outlet Hose (Pass. Side); Cut-to-fit  
 Ford; Excursion; 2005-2002; V-8 5.4 Eng.; Aux. Cooler Inlet Hose (Upper); Cut-to-fit  
 Ford; Excursion; 2005-2002; V-8 5.4 Eng.; Aux. Cooler Outlet Hose (Lower); Cut-to-fit  
 Ford; Excursion; 2001; V-8 5.4 Eng.; Aux. Cooler Inlet Hose (Upper); 2-25 & Newer; Cut-to-fit  
 Ford; Excursion; 2001; V-8 5.4 Eng.; Aux. Cooler Outlet Hose (Lower); 2-25 & Newer; Cut-to-fit  
 Ford; Excursion; 2002; V-8 7.3 Diesel Eng.; Aux. Cooler Inlet Hose (Upper); Cut-to-fit  
 Ford; Excursion; 2002; V-8 7.3 Diesel Eng.; Aux. Cooler Outlet Hose (Lower); Cut-to-fit  
 Ford; Excursion; 2001; V-8 7.3 Diesel Eng.; Aux. Cooler Inlet Hose (Upper); 2-25 & Newer; Cut-to-fit  
 Ford; Excursion; 2001; V-8 7.3 Diesel Eng.; Aux. Cooler Outlet Hose (Lower); 2-25 & Newer; Cut-to-fit  
 Ford; Excursion; 2005-2001; V-10 6.8 Eng.; Aux. Cooler Inlet Hose (Upper); Cut-to-fit  
 Ford; Excursion; 2005-2001; V-10 6.8 Eng.; Aux. Cooler Outlet Hose (Lower); Cut-to-fit  
 Ford; Explorer; 2002-1997; V-6 4.0 Eng.; Aux. Cooler Hose; Cut-to-fit  
 Ford; Explorer; 1996-1991; V-6 4.0 Eng.; Inlet Hose; Cut-to-fit  
 Ford; Explorer; 1996-1991; V-6 4.0 Eng.; Outlet Hose; Cut-to-fit  
 Ford; Explorer; 2001-1998; V-8 5.0 Eng.; Aux. Cooler Hose; Cut-to-fit  
 Ford; Explorer Sport Trac; 2002-2001; V-6 4.0 Eng.; Aux. Cooler Hose; Cut-to-fit  
 Ford; Mustang; 1993-1988; 4-Cyl. 2.3 Eng.; Inlet Hose; W/4-Spd Trans.; Cut-to-fit  
 Ford; Mustang; 1993-1988; 4-Cyl. 2.3 Eng.; Outlet Hose; W/4-Spd Trans.; Cut-to-fit  
 Ford; Mustang; 1993-1989; V-8 5.0 Eng.; Inlet Hose; W/4-Spd Trans.; Cut-to-fit  
 Ford; Mustang; 1993-1989; V-8 5.0 Eng.; Outlet Hose; W/4-Spd Trans.; Cut-to-fit  
 Ford; Ranger; 2003-1998; V-6 3.0 Eng.; Aux. Cooler Inlet Hose (Pass. Side); Cut-to-fit  
 Ford; Ranger; 2003-1998; V-6 3.0 Eng.; Aux. Cooler Outlet Hose (Driver Side); Cut-to-fit  
 Ford; Ranger; 2003-1998; V-6 4.0 Eng.; Aux. Cooler Inlet Hose (Pass. Side); Cut-to-fit  
 Ford; Ranger; 2003-1998; V-6 4.0 Eng.; Aux. Cooler Outlet Hose (Driver Side); Cut-to-fit  
 Ford; Super Duty Pickup; 2002; V-8 5.4 Eng.; Aux. Cooler Inlet Hose (Upper); Cut-to-fit  
 Ford; Super Duty Pickup; 2002; V-8 5.4 Eng.; Aux. Cooler Outlet Hose (Lower); Cut-to-fit  
 Ford; Super Duty Pickup; 2001; V-8 5.4 Eng.; Aux. Cooler Inlet Hose (Upper); 2-25 & Newer; Cut-to-fit  
 Ford; Super Duty Pickup; 2001; V-8 5.4 Eng.; Aux. Cooler Outlet Hose (Lower); 2-25 & Newer; Cut-to-fit  
 Ford; Super Duty Pickup; 2002; V-8 7.3 Diesel Eng.; Aux. Cooler Inlet Hose (Upper); Cut-to-fit  
 Ford; Super Duty Pickup; 2002; V-8 7.3 Diesel Eng.; Aux. Cooler Outlet Hose (Lower); Cut-to-fit  
 Ford; Super Duty Pickup; 2001; V-8 7.3 Diesel Eng.; Aux. Cooler Inlet Hose (Upper); 2-25 & Newer; Cut-to-fit  
 Ford; Super Duty Pickup; 2001; V-8 7.3 Diesel Eng.; Aux. Cooler Outlet Hose (Lower); 2-25 & Newer; Cut-to-fit  
 Ford; Super Duty Pickup; 2002; V-10 6.8 Eng.; Aux. Cooler Inlet Hose (Upper); Cut-to-fit  
 Ford; Super Duty Pickup; 2002; V-10 6.8 Eng.; Aux. Cooler Outlet Hose (Lower); Cut-to-fit  
 Ford; Super Duty Pickup; 2001; V-10 6.8 Eng.; Aux. Cooler Inlet Hose (Upper); 2-25 & Newer; Cut-to-fit  
 Ford; Super Duty Pickup; 2001; V-10 6.8 Eng.; Aux. Cooler Outlet Hose (Lower); 2-25 & Newer; Cut-to-fit  
 Ford; Super Duty Van; 2003-1997; V-8 5.4 Eng.; Aux. Cooler Inlet Hose (Driver Side); Cut-to-fit  
 Ford; Super Duty Van; 2003-1997; V-8 5.4 Eng.; Aux. Cooler Outlet Hose (Pass. Side); Cut-to-fit

# Numerical Listing - Oil Cooler Assemblies & End Fittings

## A63001 - Continued

Ford; Super Duty Van; 2003-1997; V-8 7.3 Diesel Eng.; Aux. Cooler Inlet Hose (Driver Side); Cut-to-fit  
 Ford; Super Duty Van; 2003-1997; V-8 7.3 Diesel Eng.; Aux. Cooler Outlet Hose (Pass. Side); Cut-to-fit  
 Ford; Super Duty Van; 2003-1997; V-10 6.8 Eng.; Aux. Cooler Inlet Hose (Driver Side); Cut-to-fit  
 Ford; Super Duty Van; 2003-1997; V-10 6.8 Eng.; Aux. Cooler Outlet Hose (Pass. Side); Cut-to-fit  
 Ford; Thunderbird; 1993-1990; V-6 3.8 Eng.; Aux. Cooler Hose; W/3/8" ID Hose; Cut-to-fit  
 Ford; Thunderbird; 1993-1991; V-8 5.0 Eng.; Aux. Cooler Hose; W/3/8" ID Hose; Cut-to-fit  
 Jeep; Cherokee; 1993-1988; 4-Cyl. 2.5 Eng.; Inlet Tube (Lower); Cut-to-fit  
 Jeep; Cherokee; 1993-1988; 4-Cyl. 2.5 Eng.; Outlet Tube (Upper) To Trans. (Front); Cut-to-fit  
 Jeep; Comanche; 1992-1988; 4-Cyl. 2.5 Eng.; Inlet Tube (Lower); Cut-to-fit  
 Jeep; Comanche; 1992-1988; 4-Cyl. 2.5 Eng.; Outlet Tube (Upper) To Trans. (Front); Cut-to-fit  
 Jeep; Grand Cherokee; 1998; V-8 5.2 Eng.; Aux. Cooler Inlet Hose; Cut-to-fit  
 Jeep; Grand Cherokee; 1998; V-8 5.2 Eng.; Aux. Cooler Outlet Hose; Cut-to-fit  
 Jeep; Grand Cherokee; 1998; V-8 5.9 Eng.; Aux. Cooler Inlet Hose; Cut-to-fit  
 Jeep; Grand Cherokee; 1998; V-8 5.9 Eng.; Aux. Cooler Outlet Hose; Cut-to-fit  
 Jeep; Grand Wagoneer; 1991-1987; V-8 5.9 Eng.; Aux. Cooler Inlet Hose  
 Jeep; Wrangler; 1995-1994; 6-Cyl. 4.0 Eng.; Outlet Hose (Pass. Side); Service Item; Cut-to-fit  
 Merc; Cougar; 1993-1990; V-6 3.8 Eng.; Aux. Cooler Hose; W/3/8" ID Hose; Cut-to-fit  
 Merc; Cougar; 1993-1991; V-8 5.0 Eng.; Aux. Cooler Hose; W/3/8" ID Hose; Cut-to-fit  
 Merc; Mountaineer; 2002-1998; V-6 4.0 Eng.; Aux. Cooler Hose; Cut-to-fit  
 Merc; Mountaineer; 2002; V-8 4.6 Eng.; Aux. Cooler Hose; Cut-to-fit  
 Merc; Mountaineer; 2001-1998; V-8 5.0 Eng.; Aux. Cooler Hose; Cut-to-fit  
 Olds; Silhouette; 1995-1992; V-6 3.8 Eng.; Outlet To Trans. (Upper); W/Aux. Cooler; Cut-to-fit  
 Olds; Toronado; 1992-1991; V-6 3.8 Eng.; Aux. Cooler Outlet Hose (Upper); Cut-to-fit  
 Pont; Lemans; 1993-1988; 4-Cyl. 1.6 Eng.; Inlet Hose; Cut-to-fit  
 Pont; Lemans; 1993-1988; 4-Cyl. 1.6 Eng.; Outlet Hose; Cut-to-fit  
 Pont; Lemans; 1990-1989; 4-Cyl. 2.0 Eng.; Inlet Hose; Cut-to-fit  
 Pont; Lemans; 1990-1989; 4-Cyl. 2.0 Eng.; Outlet Hose; Cut-to-fit  
 Pont; Trans Sport; 1995-1992; V-6 3.8 Eng.; Outlet Hose To Trans. (Upper); W/Aux. Cooler; Cut-to-fit

## A63003

Dodge; D & W Pickup; 1993-1989; 6-Cyl. 5.9 Diesel Eng.; Hose From Oil Cooler To Tube (Upper); Cut-to-fit  
 Dodge; Ram Pickup; 1998-1994; 6-Cyl. 5.9 Diesel Eng.; Oil Cooler Tube Connector (Upper Front); Cut-to-fit

## A63004

Buick; Century; 1993; 4-Cyl. 2.2 Eng.; Inlet From Rad (Upper); Cut-to-fit  
 Buick; Century; 1993; 4-Cyl. 2.2 Eng.; Inlet To Trans. (Upper); Cut-to-fit  
 Buick; Century; 1993; 4-Cyl. 2.2 Eng.; Outlet From Rad (Lower); Cut-to-fit  
 Buick; Century; 1993; 4-Cyl. 2.2 Eng.; Outlet To Trans. (Lower); Cut-to-fit  
 Buick; Century; 1992-1990; 4-Cyl. 2.5 Eng.; Inlet From Rad (Upper); Cut-to-fit  
 Buick; Century; 1992-1990; 4-Cyl. 2.5 Eng.; Inlet To Trans. (Upper); Cut-to-fit  
 Buick; Century; 1992-1990; 4-Cyl. 2.5 Eng.; Outlet From Rad (Lower); Cut-to-fit  
 Buick; Century; 1992-1990; 4-Cyl. 2.5 Eng.; Outlet To Trans. (Lower); Cut-to-fit  
 Buick; Century; 1989-1988; 4-Cyl. 2.5 Eng.; Inlet Tube From Rad (Upper); Cut-to-fit  
 Buick; Century; 1989-1988; 4-Cyl. 2.5 Eng.; Inlet Tube To Trans. (Upper); Cut-to-fit  
 Buick; Century; 1989-1988; 4-Cyl. 2.5 Eng.; Outlet Tube From Rad (Lower); Cut-to-fit  
 Buick; Century; 1989-1988; 4-Cyl. 2.5 Eng.; Outlet Tube To Trans. (Lower); Cut-to-fit  
 Buick; Century; 1989-1988; V-6 2.8 Eng.; Inlet Tube From Rad (Upper); Cut-to-fit  
 Buick; Century; 1989-1988; V-6 2.8 Eng.; Inlet Tube To Trans. (Upper); Cut-to-fit  
 Buick; Century; 1989-1988; V-6 2.8 Eng.; Outlet Tube From Rad (Lower); Cut-to-fit

## A63004 - Continued

Buick; Century; 1989-1988; V-6 2.8 Eng.; Outlet Tube To Trans. (Lower); Cut-to-fit  
 Buick; Century; 1996-1994; V-6 3.1 Eng.; Inlet Tube From Rad (Upper); Cut-to-fit  
 Buick; Century; 1996-1994; V-6 3.1 Eng.; Outlet Tube From Rad (Lower); Cut-to-fit  
 Buick; Century; 1993-1990; V-6 3.3 Eng.; Inlet From Rad (Upper); Cut-to-fit  
 Buick; Century; 1993-1990; V-6 3.3 Eng.; Inlet To Trans. (Upper); Cut-to-fit  
 Buick; Century; 1993-1990; V-6 3.3 Eng.; Outlet From Rad (Lower); Cut-to-fit  
 Buick; Century; 1993-1990; V-6 3.3 Eng.; Outlet To Trans. (Lower); Cut-to-fit  
 Buick; Century; 1989; V-6 3.3 Eng.; Inlet Tube From Rad (Upper); Cut-to-fit  
 Buick; Century; 1989; V-6 3.3 Eng.; Inlet Tube To Trans. (Upper); Cut-to-fit  
 Buick; Century; 1989; V-6 3.3 Eng.; Outlet Tube From Rad (Lower); Cut-to-fit  
 Buick; Century; 1989; V-6 3.3 Eng.; Outlet Tube To Trans. (Lower); Cut-to-fit  
 Buick; Century; 1988; V-6 3.8 Eng.; Inlet Tube From Rad (Upper); Cut-to-fit  
 Buick; Century; 1988; V-6 3.8 Eng.; Inlet Tube To Trans. (Upper); Cut-to-fit  
 Buick; Century; 1988; V-6 3.8 Eng.; Outlet Tube From Rad (Lower); Cut-to-fit  
 Buick; Century; 1988; V-6 3.8 Eng.; Outlet Tube To Trans. (Lower); Cut-to-fit  
 Buick; Electra; 1989-1988; V-8 5.0 Eng.; Inlet Hose From Rad (Upper); W/O Aux. Cooler; Cut-to-fit  
 Buick; Lesabre; 1990-1988; V-8 5.0 Eng.; Inlet Hose From Rad (Upper); W/O Aux. Cooler; Cut-to-fit  
 Buick; Reatta; 1990-1988; V-6 3.8 Eng.; Inlet Tube (Upper)  
 Buick; Reatta; 1990-1988; V-6 3.8 Eng.; Outlet Tube (Lower)  
 Buick; Regal; 1989-1988; V-6 2.8 Eng.; Outlet Tube From Rad (Lower); Cut-to-fit  
 Buick; Regal; 1991; V-6 3.1 Eng.; Inlet Tube From Rad (Upper); W/5/16" Tubing; Cut-to-fit  
 Buick; Regal; 1991; V-6 3.1 Eng.; Inlet Tube To Trans. (Upper); W/5/16" Tubing; Cut-to-fit  
 Buick; Regal; 1991; V-6 3.1 Eng.; Outlet Tube From Rad (Lower); W/5/16" Tubing; Cut-to-fit  
 Buick; Regal; 1991; V-6 3.1 Eng.; Outlet Tube To Trans. (Lower); W/5/16" Tubing; Cut-to-fit  
 Buick; Regal; 1990-1989; V-6 3.1 Eng.; Outlet Tube From Rad (Lower); Cut-to-fit  
 Buick; Regal; 1987-1986; V-6 3.8 Eng.; Inlet Tube (Upper); Cut-to-fit  
 Buick; Regal; 1987-1986; V-6 3.8 Eng.; Outlet Tube (Lower); Cut-to-fit  
 Buick; Regal; 1987-1986; V-8 5.0 Eng.; Inlet Tube (Upper); Cut-to-fit  
 Buick; Regal; 1987-1986; V-8 5.0 Eng.; Outlet Tube (Lower); Cut-to-fit  
 Buick; Riviera; 1990; V-6 3.8 Eng.; Aux. Cooler Outlet Tube (Upper); Cut-to-fit  
 Buick; Riviera; 1990; V-6 3.8 Eng.; Inlet Tube From Rad To Trans. (Lower); Cut-to-fit  
 Buick; Riviera; 1990; V-6 3.8 Eng.; Outlet Tube From Rad (Upper) To Aux. Cooler (Lower); Cut-to-fit  
 Buick; Riviera; 1990; V-6 3.8 Eng.; Outlet Tube To Trans. (Upper); Cut-to-fit  
 Buick; Riviera; 1989-1986; V-6 3.8 Eng.; Inlet Tube (Upper); Cut-to-fit  
 Buick; Riviera; 1989-1986; V-6 3.8 Eng.; Outlet Tube (Upper); Cut-to-fit  
 Buick; Roadmaster; 1991; V-8 5.0 Eng.; Inlet Tube (Upper); Cut-to-fit  
 Buick; Roadmaster; 1991; V-8 5.0 Eng.; Outlet Tube (Lower); Cut-to-fit  
 Buick; Roadmaster; 1993-1992; V-8 5.7 Eng.; Inlet Tube (Upper); Cut-to-fit  
 Buick; Roadmaster; 1993-1992; V-8 5.7 Eng.; Outlet Tube (Lower); Cut-to-fit  
 Cad; Cimarron; 1986-1985; 4-Cyl. 2.0 Eng.; Inlet (Upper); Cut-to-fit  
 Cad; Cimarron; 1986-1985; 4-Cyl. 2.0 Eng.; Outlet (Lower); Cut-to-fit  
 Cad; Deville; 1990-1988; V-8 4.5 Eng.; Inlet Tube From Rad (Upper); Cut-to-fit  
 Cad; Deville; 1990-1988; V-8 4.5 Eng.; Outlet Tube From Rad (Lower); Cut-to-fit  
 Cad; Eldorado; 1990; V-8 4.5 Eng.; Aux. Cooler Outlet Hose (Upper); Cut-to-fit  
 Cad; Eldorado; 1990; V-8 4.5 Eng.; Inlet Hose From Rad To Trans. (Lower); Cut-to-fit  
 Cad; Eldorado; 1990; V-8 4.5 Eng.; Outlet Hose From Rad (Upper) To Aux. Cooler (Lower); Cut-to-fit  
 Cad; Eldorado; 1990; V-8 4.5 Eng.; Outlet Hose To Trans. (Upper); Cut-to-fit  
 Cad; Fleetwood; 1990-1988; V-8 4.5 Eng.; Inlet Tube From Rad (Upper); Cut-to-fit

# Numerical Listing - Oil Cooler Assemblies & End Fittings

Product Section

Troubleshooting

EOC Applications

TOC Applications

Numerical Listing

Manufacturers' Part Numbers

End Fittings

Illustrations

## A63004 - Continued

Cad; Fleetwood; 1990-1988; V-8 4.5 Eng.; Outlet Tube From Rad (Lower); Cut-to-fit  
 Cad; Fleetwood; 1993; V-8 5.7 Eng.; Inlet From Rad (Upper); Cut-to-fit  
 Cad; Fleetwood; 1993; V-8 5.7 Eng.; Outlet From Rad (Lower); Cut-to-fit  
 Cad; Seville; 1990; V-8 4.5 Eng.; Aux. Cooler Outlet Tube (Upper); Cut-to-fit  
 Cad; Seville; 1990; V-8 4.5 Eng.; Inlet Tube From Rad To Trans. (Lower); Cut-to-fit  
 Cad; Seville; 1990; V-8 4.5 Eng.; Outlet Tube From Rad (Upper) To Aux. Cooler (Lower); Cut-to-fit  
 Cad; Seville; 1990; V-8 4.5 Eng.; Outlet Tube To Trans. (Upper); Cut-to-fit  
 Chev; Astro; 1990-1985; 4-Cyl. 2.5 Eng.; Inlet Tube (Upper); Cut-to-fit  
 Chev; Astro; 1990-1985; 4-Cyl. 2.5 Eng.; Outlet Tube (Lower); Cut-to-fit  
 Chev; Astro; 1994-1985; V-6 4.3 Eng.; Inlet Tube (Upper); Cut-to-fit  
 Chev; Astro; 1994-1985; V-6 4.3 Eng.; Outlet Tube (Lower); Cut-to-fit  
 Chev; Blazer; 1995; V-6 4.3 Eng.; Inlet Tube (Lower); Cut-to-fit  
 Chev; Blazer; 1995; V-6 4.3 Eng.; Outlet Tube (Upper); Cut-to-fit  
 Chev; Blazer Compact; 1988-1987; 4-Cyl. 2.5 Eng.; Inlet Tube; Cut-to-fit  
 Chev; Blazer Compact; 1988-1987; 4-Cyl. 2.5 Eng.; Outlet Tube; Cut-to-fit  
 Chev; Blazer Compact; 1989-1987; V-6 2.8 Eng.; Inlet Tube; Cut-to-fit  
 Chev; Blazer Compact; 1989-1987; V-6 2.8 Eng.; Outlet Tube; Cut-to-fit  
 Chev; Blazer Compact; 1994-1993; V-6 4.3 Eng.; Inlet Tube (Lower); Cut-to-fit  
 Chev; Blazer Compact; 1994-1993; V-6 4.3 Eng.; Outlet Tube (Upper); Cut-to-fit  
 Chev; Blazer Compact; 1992-1988; V-6 4.3 Eng.; Inlet Tube; Cut-to-fit  
 Chev; Blazer Compact; 1992-1988; V-6 4.3 Eng.; Outlet Tube; Cut-to-fit  
 Chev; Blazer Full Size; 1987; V-8 5.0 Eng.; Inlet Tube; Cut-to-fit  
 Chev; Blazer Full Size; 1987; V-8 5.0 Eng.; Outlet Tube; Cut-to-fit  
 Chev; Blazer Full Size; 1994-1993; V-8 5.7 Eng.; Inlet Tube (Upper); Cut-to-fit  
 Chev; Blazer Full Size; 1994-1993; V-8 5.7 Eng.; Outlet Tube (Lower); W/O Aux. Cooler; Cut-to-fit  
 Chev; Blazer Full Size; 1992-1987; V-8 5.7 Eng.; Inlet Tube; Cut-to-fit  
 Chev; Blazer Full Size; 1992-1987; V-8 5.7 Eng.; Outlet Tube; Cut-to-fit  
 Chev; Blazer Full Size; 1991-1987; V-8 6.2 Diesel Eng.; Inlet Tube; Cut-to-fit  
 Chev; Blazer Full Size; 1991-1987; V-8 6.2 Diesel Eng.; Outlet Tube; Cut-to-fit  
 Chev; Blazer Full Size; 1994; V-8 6.5 Diesel Eng.; Inlet Tube (Upper); Cut-to-fit  
 Chev; Blazer Full Size; 1994; V-8 6.5 Diesel Eng.; Outlet Tube (Lower); W/O Aux. Cooler; Cut-to-fit  
 Chev; C&K Pickup; 1986-1985; 6-Cyl. 4.8 Eng.; Inlet (Upper); Cut-to-fit  
 Chev; C&K Pickup; 1986-1985; 6-Cyl. 4.8 Eng.; Outlet (Lower); Cut-to-fit  
 Chev; C&K Pickup; 1995-1994; V-6 4.3 Eng.; Inlet (Upper); Cut-to-fit  
 Chev; C&K Pickup; 1995-1994; V-6 4.3 Eng.; Outlet (Lower); Cut-to-fit  
 Chev; C&K Pickup; 1993; V-6 4.3 Eng.; Inlet (Lower); Cut-to-fit  
 Chev; C&K Pickup; 1993; V-6 4.3 Eng.; Outlet (Upper); Cut-to-fit  
 Chev; C&K Pickup; 1992-1988; V-6 4.3 Eng.; Inlet (Upper); Cut-to-fit  
 Chev; C&K Pickup; 1992-1988; V-6 4.3 Eng.; Outlet (Lower); Cut-to-fit  
 Chev; C&K Pickup; 1986-1985; V-6 4.3 Eng.; Inlet (Upper); Cut-to-fit  
 Chev; C&K Pickup; 1986-1985; V-6 4.3 Eng.; Outlet (Lower); Cut-to-fit  
 Chev; C&K Pickup; 1995-1994; V-8 5.0 Eng.; Inlet (Upper); Cut-to-fit  
 Chev; C&K Pickup; 1995-1994; V-8 5.0 Eng.; Outlet (Lower); Cut-to-fit  
 Chev; C&K Pickup; 1993; V-8 5.0 Eng.; Inlet (Lower); Cut-to-fit  
 Chev; C&K Pickup; 1993; V-8 5.0 Eng.; Outlet (Upper); Cut-to-fit  
 Chev; C&K Pickup; 1992-1988; V-8 5.0 Eng.; Inlet (Upper); Cut-to-fit  
 Chev; C&K Pickup; 1992-1988; V-8 5.0 Eng.; Outlet (Lower); Cut-to-fit  
 Chev; C&K Pickup; 1986-1985; V-8 5.0 Eng.; Inlet (Upper); Cut-to-fit  
 Chev; C&K Pickup; 1986-1985; V-8 5.0 Eng.; Outlet (Lower); Cut-to-fit  
 Chev; C&K Pickup; 1995-1993; V-8 5.7 Eng.; Inlet (Upper); W/Aux. Cooler; Cut-to-fit  
 Chev; C&K Pickup; 1995-1993; V-8 5.7 Eng.; Inlet (Upper); W/O Aux. Cooler; Cut-to-fit  
 Chev; C&K Pickup; 1995-1993; V-8 5.7 Eng.; Outlet (Lower); W/O Aux. Cooler; Cut-to-fit  
 Chev; C&K Pickup; 1992-1988; V-8 5.7 Eng.; Inlet (Upper); Cut-to-fit  
 Chev; C&K Pickup; 1992-1988; V-8 5.7 Eng.; Outlet (Lower); Cut-to-fit  
 Chev; C&K Pickup; 1986-1985; V-8 5.7 Eng.; Inlet (Upper); Cut-to-fit  
 Chev; C&K Pickup; 1986-1985; V-8 5.7 Eng.; Outlet (Lower); Cut-to-fit  
 Chev; C&K Pickup; 1993-1988; V-8 6.2 Diesel Eng.; Inlet (Upper); Cut-to-fit  
 Chev; C&K Pickup; 1993-1988; V-8 6.2 Diesel Eng.; Outlet (Lower); Cut-to-fit  
 Chev; C&K Pickup; 1986-1985; V-8 6.2 Diesel Eng.; Inlet (Upper); Cut-to-fit  
 Chev; C&K Pickup; 1986-1985; V-8 6.2 Diesel Eng.; Outlet (Lower); Cut-to-fit  
 Chev; C&K Pickup; 1995-1992; V-8 6.5 Diesel Eng.; Inlet (Upper); Cut-to-fit  
 Chev; C&K Pickup; 1992; V-8 6.5 Diesel Eng.; Outlet (Lower); Cut-to-fit  
 Chev; C&K Pickup; 1995-1988; V-8 7.4 Eng.; Inlet (Upper); Cut-to-fit

## A63004 - Continued

Chev; C&K Pickup; 1992-1988; V-8 7.4 Eng.; Outlet (Lower); Cut-to-fit  
 Chev; C&K Pickup; 1986-1985; V-8 7.4 Eng.; Inlet (Upper); Cut-to-fit  
 Chev; C&K Pickup; 1986-1985; V-8 7.4 Eng.; Outlet (Lower); Cut-to-fit  
 Chev; Camaro; 1986-1983; 4-Cyl. 2.5 Eng.; Inlet (Upper); Cut-to-fit  
 Chev; Camaro; 1986-1983; 4-Cyl. 2.5 Eng.; Outlet (Lower); Cut-to-fit  
 Chev; Camaro; 1989-1983; V-6 2.8 Eng.; Inlet (Upper); Cut-to-fit  
 Chev; Camaro; 1989-1983; V-6 2.8 Eng.; Outlet (Lower); Cut-to-fit  
 Chev; Camaro; 1992-1990; V-6 3.1 Eng.; Inlet (Upper); Cut-to-fit  
 Chev; Camaro; 1992-1990; V-6 3.1 Eng.; Outlet (Lower); Cut-to-fit  
 Chev; Camaro; 1995-1993; V-6 3.4 Eng.; Inlet Tube To Trans. (Upper); Cut-to-fit  
 Chev; Camaro; 1995-1993; V-6 3.4 Eng.; Outlet Tube From Rad (Lower); Cut-to-fit  
 Chev; Camaro; 1995-1993; V-6 3.4 Eng.; Outlet Tube To Trans. (Lower); Cut-to-fit  
 Chev; Camaro; 1997-1995; V-6 3.8 Eng.; Inlet Tube To Trans. (Upper); Cut-to-fit  
 Chev; Camaro; 1997-1995; V-6 3.8 Eng.; Outlet Tube From Rad (Lower); Cut-to-fit  
 Chev; Camaro; 1997-1995; V-6 3.8 Eng.; Outlet Tube To Trans. (Lower); Cut-to-fit  
 Chev; Camaro; 1992-1983; V-8 5.0 Eng.; Inlet (Upper); Cut-to-fit  
 Chev; Camaro; 1992-1983; V-8 5.0 Eng.; Outlet (Lower); Cut-to-fit  
 Chev; Camaro; 1997-1993; V-8 5.7 Eng.; Inlet Tube To Trans. (Upper); Cut-to-fit  
 Chev; Camaro; 1997-1993; V-8 5.7 Eng.; Outlet Tube From Rad (Lower); Cut-to-fit  
 Chev; Camaro; 1997-1993; V-8 5.7 Eng.; Outlet Tube To Trans. (Lower); Cut-to-fit  
 Chev; Camaro; 1992-1987; V-8 5.7 Eng.; Inlet (Upper); Cut-to-fit  
 Chev; Camaro; 1992-1987; V-8 5.7 Eng.; Outlet (Lower); Cut-to-fit  
 Chev; Caprice; 1993-1992; V-6 4.3 Eng.; Inlet (Upper); Cut-to-fit  
 Chev; Caprice; 1993-1992; V-6 4.3 Eng.; Outlet (Lower); Cut-to-fit  
 Chev; Caprice; 1990-1985; V-6 4.3 Eng.; Inlet (Upper); Cut-to-fit  
 Chev; Caprice; 1990-1985; V-6 4.3 Eng.; Outlet (Lower); Cut-to-fit  
 Chev; Caprice; 1993; V-8 5.0 Eng.; Inlet (Upper); W/O Aux. Cooler; Cut-to-fit  
 Chev; Caprice; 1993-1985; V-8 5.0 Eng.; Outlet (Lower); Cut-to-fit  
 Chev; Caprice; 1992-1985; V-8 5.0 Eng.; Inlet (Upper); Cut-to-fit  
 Chev; Caprice; 1993; V-8 5.7 Eng.; Inlet (Upper); W/O Aux. Cooler; Cut-to-fit  
 Chev; Caprice; 1993-1986; V-8 5.7 Eng.; Outlet (Lower); Cut-to-fit  
 Chev; Caprice; 1992-1986; V-8 5.7 Eng.; Inlet (Upper); Cut-to-fit  
 Chev; Caprice; 1985; V-8 5.7 Diesel Eng.; Inlet (Upper); Cut-to-fit  
 Chev; Caprice; 1985; V-8 5.7 Diesel Eng.; Outlet (Lower); Cut-to-fit  
 Chev; Celebrity; 1990-1985; 4-Cyl. 2.5 Eng.; Inlet Tube From Rad (Upper); Cut-to-fit  
 Chev; Celebrity; 1990-1985; 4-Cyl. 2.5 Eng.; Inlet Tube To Trans. (Upper); Cut-to-fit  
 Chev; Celebrity; 1990-1985; 4-Cyl. 2.5 Eng.; Outlet Tube From Rad (Lower); Cut-to-fit  
 Chev; Celebrity; 1990-1985; 4-Cyl. 2.5 Eng.; Outlet Tube To Trans. (Lower); Cut-to-fit  
 Chev; Celebrity; 1989-1985; V-6 2.8 Eng.; Inlet Tube From Rad (Upper); Cut-to-fit  
 Chev; Celebrity; 1989-1985; V-6 2.8 Eng.; Inlet Tube To Trans. (Upper); Cut-to-fit  
 Chev; Celebrity; 1989-1985; V-6 2.8 Eng.; Outlet Tube From Rad (Lower); Cut-to-fit  
 Chev; Celebrity; 1989-1985; V-6 2.8 Eng.; Outlet Tube To Trans. (Lower); Cut-to-fit  
 Chev; Celebrity; 1990; V-6 3.1 Eng.; Inlet Tube From Rad (Upper); Cut-to-fit  
 Chev; Celebrity; 1990; V-6 3.1 Eng.; Inlet Tube To Trans. (Upper); Cut-to-fit  
 Chev; Celebrity; 1990; V-6 3.1 Eng.; Outlet Tube From Rad (Lower); Cut-to-fit  
 Chev; Celebrity; 1990; V-6 3.1 Eng.; Outlet Tube To Trans. (Lower); Cut-to-fit  
 Chev; Corvette; 1996-1984; V-8 5.7 Eng.; Inlet (Upper); Cut-to-fit  
 Chev; Corvette; 1996-1984; V-8 5.7 Eng.; Outlet (Lower); Cut-to-fit  
 Chev; El Camino; 1987-1986; V-6 4.3 Eng.; Inlet (Upper); Cut-to-fit  
 Chev; El Camino; 1987-1986; V-6 4.3 Eng.; Outlet (Lower); Cut-to-fit  
 Chev; El Camino; 1987-1986; V-8 5.0 Eng.; Inlet (Upper); Cut-to-fit  
 Chev; El Camino; 1987-1986; V-8 5.0 Eng.; Outlet (Lower); Cut-to-fit  
 Chev; G Van; 1996-1986; V-6 4.3 Eng.; Inlet (Upper); Cut-to-fit  
 Chev; G Van; 1996-1994; V-6 4.3 Eng.; Outlet (Lower); W/O Aux. Cooler; Cut-to-fit  
 Chev; G Van; 1995-1994; V-6 4.3 Eng.; Outlet (Lower); W/Aux. Cooler; W/17-Bolt Trans. Pan (MT1); Cut-to-fit  
 Chev; G Van; 1993-1986; V-6 4.3 Eng.; Outlet (Lower); Cut-to-fit  
 Chev; G Van; 1995-1986; V-8 5.0 Eng.; Inlet (Upper); Cut-to-fit



# Numerical Listing - Oil Cooler Assemblies & End Fittings

## A63004 - Continued

Chev; G Van; 1995-1994; V-8 5.0 Eng.; Outlet (Lower); W/Aux. Cooler; W/17-Bolt Trans. Pan (MT1); Cut-to-fit  
 Chev; G Van; 1995-1994; V-8 5.0 Eng.; Outlet (Lower); W/O Aux. Cooler; Cut-to-fit  
 Chev; G Van; 1993-1986; V-8 5.0 Eng.; Outlet (Lower); Cut-to-fit  
 Chev; G Van; 1996-1986; V-8 5.7 Eng.; Inlet (Upper); Cut-to-fit  
 Chev; G Van; 1996-1994; V-8 5.7 Eng.; Outlet (Lower); W/O Aux. Cooler; Cut-to-fit  
 Chev; G Van; 1995-1994; V-8 5.7 Eng.; Outlet (Lower); W/Aux. Cooler; W/17-Bolt Trans. Pan (MT1); Cut-to-fit  
 Chev; G Van; 1993-1986; V-8 5.7 Eng.; Outlet (Lower); Cut-to-fit  
 Chev; G Van; 1993-1986; V-8 6.2 Diesel Eng.; Inlet (Upper); Cut-to-fit  
 Chev; G Van; 1993-1986; V-8 6.2 Diesel Eng.; Outlet (Lower); Cut-to-fit  
 Chev; G Van; 1996-1994; V-8 6.5 Diesel Eng.; Inlet (Upper); Cut-to-fit  
 Chev; G Van; 1996-1994; V-8 6.5 Diesel Eng.; Outlet (Lower); W/O Aux. Cooler; Cut-to-fit  
 Chev; G Van; 1995-1994; V-8 6.5 Diesel Eng.; Outlet (Lower); W/Aux. Cooler; W/17-Bolt Trans. Pan (MT1); Cut-to-fit  
 Chev; G Van; 1996-1988; V-8 7.4 Eng.; Inlet (Upper); Cut-to-fit  
 Chev; G Van; 1996-1994; V-8 7.4 Eng.; Outlet (Lower); W/O Aux. Cooler; Cut-to-fit  
 Chev; G Van; 1993-1988; V-8 7.4 Eng.; Outlet (Lower); Cut-to-fit  
 Chev; Impala; 1985; V-6 4.3 Eng.; Inlet (Upper); Cut-to-fit  
 Chev; Impala; 1985; V-6 4.3 Eng.; Outlet (Lower); Cut-to-fit  
 Chev; Impala; 1985; V-8 5.0 Eng.; Inlet (Upper); Cut-to-fit  
 Chev; Impala; 1985; V-8 5.0 Eng.; Outlet (Lower); Cut-to-fit  
 Chev; Impala; 1985; V-8 5.7 Eng.; Inlet (Upper); Cut-to-fit  
 Chev; Impala; 1985; V-8 5.7 Eng.; Outlet (Lower); Cut-to-fit  
 Chev; LLV (Postal Vehicle); 1995-1994; 4-Cyl. 2.2 Eng.; Inlet Tube  
 Chev; LLV (Postal Vehicle); 1995-1994; 4-Cyl. 2.2 Eng.; Outlet Tube  
 Chev; LLV (Postal Vehicle); 1993-1987; 4-Cyl. 2.5 Eng.; Inlet Tube  
 Chev; LLV (Postal Vehicle); 1993-1987; 4-Cyl. 2.5 Eng.; Outlet Tube  
 Chev; Lumina; 1992-1990; 4-Cyl. 2.5 Eng.; Inlet Tube To Trans. (Upper); Cut-to-fit  
 Chev; Lumina; 1992-1990; 4-Cyl. 2.5 Eng.; Outlet Tube To Trans. (Lower); Cut-to-fit  
 Chev; Lumina; 1993-1990; V-6 3.1 Eng.; Inlet Tube To Trans. (Upper); W/3-Spd Trans.; Cut-to-fit  
 Chev; Lumina; 1993-1991; V-6 3.1 Eng.; Outlet Tube To Trans. (Lower); W/3-Spd Trans.; Cut-to-fit  
 Chev; Lumina; 1990; V-6 3.1 Eng.; Inlet Tube From Rad (Upper); W/4-Spd Trans.; Cut-to-fit  
 Chev; Lumina; 1990; V-6 3.1 Eng.; Outlet Tube From Rad (Lower); W/4-Spd Trans.; Cut-to-fit  
 Chev; Lumina; 1990; V-6 3.1 Eng.; Outlet Tube To Trans. (Lower); Cut-to-fit  
 Chev; Lumina APV; 1995-1990; V-6 3.1 Eng.; Inlet From Rad (Upper); Cut-to-fit  
 Chev; Lumina APV; 1995-1990; V-6 3.1 Eng.; Outlet From Rad (Lower); Cut-to-fit  
 Chev; Lumina APV; 1995-1990; V-6 3.1 Eng.; Rad Supply Tube (Upper To Lower); Cut-to-fit  
 Chev; Monte Carlo; 1984-1982; V-6 3.8 Eng.; Inlet Tube (Upper); Cut-to-fit  
 Chev; Monte Carlo; 1984-1982; V-6 3.8 Eng.; Outlet Tube (Lower); Cut-to-fit  
 Chev; Monte Carlo; 1988-1985; V-6 4.3 Eng.; Inlet Tube (Upper); Cut-to-fit  
 Chev; Monte Carlo; 1988-1985; V-6 4.3 Eng.; Outlet Tube (Lower); Cut-to-fit  
 Chev; Monte Carlo; 1988-1982; V-8 5.0 Eng.; Inlet Tube (Upper); Cut-to-fit  
 Chev; Monte Carlo; 1988-1982; V-8 5.0 Eng.; Outlet Tube (Lower); Cut-to-fit  
 Chev; R&V Pickup; 1988-1987; 6-Cyl. 4.8 Eng.; Inlet (Upper); Cut-to-fit  
 Chev; R&V Pickup; 1988-1987; 6-Cyl. 4.8 Eng.; Outlet (Lower); Cut-to-fit  
 Chev; R&V Pickup; 1987; V-6 4.3 Eng.; Inlet (Upper); Cut-to-fit  
 Chev; R&V Pickup; 1987; V-6 4.3 Eng.; Outlet (Lower); Cut-to-fit  
 Chev; R&V Pickup; 1991-1987; V-8 5.7 Eng.; Inlet (Upper); Cut-to-fit  
 Chev; R&V Pickup; 1991-1987; V-8 5.7 Eng.; Outlet (Lower); Cut-to-fit  
 Chev; R&V Pickup; 1991-1987; V-8 6.2 Diesel Eng.; Inlet (Upper); Cut-to-fit  
 Chev; R&V Pickup; 1991-1987; V-8 6.2 Diesel Eng.; Outlet (Lower); Cut-to-fit  
 Chev; R&V Pickup; 1991-1987; V-8 7.4 Eng.; Inlet (Upper); Cut-to-fit  
 Chev; R&V Pickup; 1991-1987; V-8 7.4 Eng.; Outlet (Lower); Cut-to-fit  
 Chev; S Pickup; 1997-1994; 4-Cyl. 2.2 Eng.; Inlet (Lower); Cut-to-fit  
 Chev; S Pickup; 1997-1994; 4-Cyl. 2.2 Eng.; Outlet (Upper); Cut-to-fit  
 Chev; S Pickup; 1993-1986; 4-Cyl. 2.5 Eng.; Inlet (Lower); Cut-to-fit  
 Chev; S Pickup; 1993-1986; 4-Cyl. 2.5 Eng.; Outlet (Upper); Cut-to-fit  
 Chev; S Pickup; 1993-1986; V-6 2.8 Eng.; Inlet (Lower); Cut-to-fit  
 Chev; S Pickup; 1993-1986; V-6 2.8 Eng.; Outlet (Upper); Cut-to-fit  
 Chev; S Pickup; 1995-1988; V-6 4.3 Eng.; Inlet (Lower); Cut-to-fit  
 Chev; S Pickup; 1995-1988; V-6 4.3 Eng.; Outlet (Upper); Cut-to-fit  
 Chev; Suburban; 1987-1985; V-8 5.0 Eng.; Inlet (Upper); Cut-to-fit  
 Chev; Suburban; 1987-1985; V-8 5.0 Eng.; Outlet (Lower); Cut-to-fit

## A63004 - Continued

Chev; Suburban; 1995-1993; V-8 5.7 Eng.; Inlet (Upper); W/Aux. Cooler; Cut-to-fit  
 Chev; Suburban; 1995-1993; V-8 5.7 Eng.; Inlet (Upper); W/O Aux. Cooler; Cut-to-fit  
 Chev; Suburban; 1995-1993; V-8 5.7 Eng.; Outlet (Lower); W/O Aux. Cooler; Cut-to-fit  
 Chev; Suburban; 1992-1985; V-8 5.7 Eng.; Inlet (Upper); Cut-to-fit  
 Chev; Suburban; 1992-1985; V-8 5.7 Eng.; Outlet (Lower); Cut-to-fit  
 Chev; Suburban; 1991-1985; V-8 6.2 Diesel Eng.; Inlet (Upper); Cut-to-fit  
 Chev; Suburban; 1991-1985; V-8 6.2 Diesel Eng.; Outlet (Lower); Cut-to-fit  
 Chev; Suburban; 1995-1994; V-8 6.5 Diesel Eng.; Inlet (Upper); Cut-to-fit  
 Chev; Suburban; 1995-1985; V-8 7.4 Eng.; Inlet (Upper); Cut-to-fit  
 Chev; Suburban; 1992-1985; V-8 7.4 Eng.; Outlet (Lower); Cut-to-fit  
 Chev; Tahoe; 1995; V-8 5.7 Eng.; Inlet (Upper); W/Aux. Cooler; Cut-to-fit  
 Chev; Tahoe; 1995; V-8 5.7 Eng.; Inlet (Upper); W/O Aux. Cooler; Cut-to-fit  
 Chev; Tahoe; 1995; V-8 5.7 Eng.; Outlet (Lower); W/O Aux. Cooler; Cut-to-fit  
 Chev; Tahoe; 1995; V-8 6.5 Diesel Eng.; Inlet (Upper); Cut-to-fit  
 Dodge; B Van; 1993-1990; V-6 3.9 Eng.; Aux. Cooler Tube; Cut-to-fit  
 Dodge; B Van; 1989-1988; V-6 3.9 Eng.; Inlet Hose; Cut-to-fit  
 Dodge; B Van; 1989-1988; V-6 3.9 Eng.; Outlet Hose; Cut-to-fit  
 Dodge; B Van; 1993-1990; V-8 5.2 Eng.; Aux. Cooler Tube; Cut-to-fit  
 Dodge; B Van; 1989-1984; V-8 5.2 Eng.; Inlet Hose; Cut-to-fit  
 Dodge; B Van; 1989-1984; V-8 5.2 Eng.; Outlet Hose; Cut-to-fit  
 Dodge; B Van; 1993-1990; V-8 5.9 Eng.; Aux. Cooler Tube; Cut-to-fit  
 Dodge; B Van; 1989-1984; V-8 5.9 Eng.; Inlet Hose; Cut-to-fit  
 Dodge; B Van; 1989-1984; V-8 5.9 Eng.; Outlet Hose; Cut-to-fit  
 Dodge; D & W Pickup; 1987-1982; 6-Cyl. 3.7 Eng.; Inlet Tube (Pass. Side); Cut-to-fit  
 Dodge; D & W Pickup; 1987-1982; 6-Cyl. 3.7 Eng.; Outlet Tube (Driver Side); Cut-to-fit  
 Dodge; D & W Pickup; 1989-1988; V-6 3.9 Eng.; Inlet Tube (Pass. Side); Cut-to-fit  
 Dodge; D & W Pickup; 1989-1988; V-6 3.9 Eng.; Outlet Tube (Driver Side); Cut-to-fit  
 Dodge; D & W Pickup; 1989-1982; V-8 5.2 Eng.; Inlet Tube (Pass. Side); Cut-to-fit  
 Dodge; D & W Pickup; 1989-1982; V-8 5.2 Eng.; Outlet Tube (Driver Side); Cut-to-fit  
 Dodge; D & W Pickup; 1989-1982; V-8 5.9 Eng.; Inlet Tube (Pass. Side); Cut-to-fit  
 Dodge; D & W Pickup; 1989-1982; V-8 5.9 Eng.; Outlet Tube (Driver Side); Cut-to-fit  
 Dodge; Dakota; 1989-1987; V-6 3.9 Eng.; Inlet Tube (Pass. Side); Cut-to-fit  
 Dodge; Dakota; 1989-1987; V-6 3.9 Eng.; Outlet Tube (Driver Side); Cut-to-fit  
 Dodge; Dakota; 1989; V-8 5.2 Eng.; Inlet Tube (Pass. Side); Cut-to-fit  
 Dodge; Dakota; 1989; V-8 5.2 Eng.; Outlet Tube (Driver Side); Cut-to-fit  
 Dodge; Ramcharger; 1989-1984; V-8 5.2 Eng.; Inlet Tube (Pass. Side); Cut-to-fit  
 Dodge; Ramcharger; 1989-1984; V-8 5.2 Eng.; Outlet Tube (Driver Side); Cut-to-fit  
 Dodge; Ramcharger; 1989-1984; V-8 5.9 Eng.; Inlet Tube (Pass. Side); Cut-to-fit  
 Dodge; Ramcharger; 1989-1984; V-8 5.9 Eng.; Outlet Tube (Driver Side); Cut-to-fit  
 Ford; Bronco; 1992-1991; 6-Cyl. 4.9 Eng.; Inlet Tube; Cut-to-fit  
 Ford; Bronco; 1992-1991; 6-Cyl. 4.9 Eng.; Outlet Tube; Cut-to-fit  
 Ford; Bronco; 1996-1991; V-8 5.0 Eng.; Inlet Tube; Cut-to-fit  
 Ford; Bronco; 1996-1991; V-8 5.0 Eng.; Outlet Tube; Cut-to-fit  
 Ford; Bronco; 1996-1991; V-8 5.8 Eng.; Inlet Tube; Cut-to-fit  
 Ford; Bronco; 1996-1991; V-8 5.8 Eng.; Outlet Tube; Cut-to-fit  
 Ford; Bronco Full Size; 1990-1988; 6-Cyl. 4.9 Eng.; Inlet Tube; Cut-to-fit  
 Ford; Bronco Full Size; 1990-1988; 6-Cyl. 4.9 Eng.; Outlet Tube; Cut-to-fit  
 Ford; Bronco Full Size; 1990-1988; V-8 5.0 Eng.; Inlet Tube; Cut-to-fit  
 Ford; Bronco Full Size; 1990-1988; V-8 5.0 Eng.; Outlet Tube; Cut-to-fit  
 Ford; Bronco Full Size; 1990-1988; V-8 5.8 Eng.; Inlet Tube; Cut-to-fit  
 Ford; Bronco Full Size; 1990-1988; V-8 5.8 Eng.; Outlet Tube; Cut-to-fit  
 Ford; Country Squire; 1991-1988; V-8 5.0 Eng.; Inlet Tube; Cut-to-fit  
 Ford; Country Squire; 1991-1988; V-8 5.0 Eng.; Outlet Tube; Cut-to-fit  
 Ford; Crown Victoria; 1997-1996; V-8 4.6 Eng.; Inlet Tube; W/O Aux. Cooler; Cut-to-fit  
 Ford; Crown Victoria; 1997-1996; V-8 4.6 Eng.; Outlet Tube; W/O Aux. Cooler; Cut-to-fit  
 Ford; Crown Victoria; 1995-1992; V-8 4.6 Eng.; Inlet Tube; Cut-to-fit  
 Ford; Crown Victoria; 1995-1992; V-8 4.6 Eng.; Outlet Tube; Cut-to-fit  
 Ford; E Van; 1996-1988; 6-Cyl. 4.9 Eng.; Inlet Tube; Cut-to-fit  
 Ford; E Van; 1996-1988; 6-Cyl. 4.9 Eng.; Outlet Tube; Cut-to-fit  
 Ford; E Van; 1996-1988; V-8 5.0 Eng.; Inlet Tube; Cut-to-fit  
 Ford; E Van; 1996-1988; V-8 5.0 Eng.; Outlet Tube; Cut-to-fit  
 Ford; E Van; 1996-1988; V-8 5.8 Eng.; Inlet Tube; Cut-to-fit  
 Ford; E Van; 1996-1988; V-8 5.8 Eng.; Outlet Tube; Cut-to-fit

Product Section

Troubleshooting

EOC Applications

TOC Applications

Numerical Listing

Manufacturers' Part Numbers

End Fittings

Illustrations

# Numerical Listing - Oil Cooler Assemblies & End Fittings

## A63004 - Continued

Ford; E Van; 1996-1988; V-8 5.8 Eng.; Outlet Tube; Cut-to-fit  
 Ford; E Van; 1996-1988; V-8 7.3 Diesel Eng.; Inlet Tube; Cut-to-fit  
 Ford; E Van; 1996-1988; V-8 7.3 Diesel Eng.; Outlet Tube; Cut-to-fit  
 Ford; E Van; 1996-1988; V-8 7.5 Eng.; Inlet Tube; Cut-to-fit  
 Ford; E Van; 1996-1988; V-8 7.5 Eng.; Outlet Tube; Cut-to-fit  
 Ford; Escort; 1990-1988; 4-Cyl. 1.9 Eng.; Inlet Tube; Cut-to-fit  
 Ford; Escort; 1990-1988; 4-Cyl. 1.9 Eng.; Outlet Tube; Cut-to-fit  
 Ford; F Pickup; 1996-1990; 6-Cyl. 4.9 Eng.; Aux. Cooler Tube; Cut-to-fit  
 Ford; F Pickup; 1996-1990; 6-Cyl. 4.9 Eng.; Inlet Tube; Cut-to-fit  
 Ford; F Pickup; 1996-1990; 6-Cyl. 4.9 Eng.; Outlet Tube; Cut-to-fit  
 Ford; F Pickup; 1996-1990; V-8 5.0 Eng.; Aux. Cooler Tube; Cut-to-fit  
 Ford; F Pickup; 1996-1990; V-8 5.0 Eng.; Inlet Tube; Cut-to-fit  
 Ford; F Pickup; 1996-1990; V-8 5.0 Eng.; Outlet Tube; Cut-to-fit  
 Ford; F Pickup; 1996-1990; V-8 5.8 Eng.; Aux. Cooler Tube; Cut-to-fit  
 Ford; F Pickup; 1996-1990; V-8 5.8 Eng.; Inlet Tube; Cut-to-fit  
 Ford; F Pickup; 1996-1990; V-8 5.8 Eng.; Outlet Tube; Cut-to-fit  
 Ford; F Pickup; 1996-1990; V-8 7.3 Diesel Eng.; Aux. Cooler Tube; Cut-to-fit  
 Ford; F Pickup; 1996-1990; V-8 7.3 Diesel Eng.; Inlet Tube; Cut-to-fit  
 Ford; F Pickup; 1996-1990; V-8 7.3 Diesel Eng.; Outlet Tube; Cut-to-fit  
 Ford; F Pickup; 1996-1990; V-8 7.5 Eng.; Aux. Cooler Tube; Cut-to-fit  
 Ford; F Pickup; 1996-1990; V-8 7.5 Eng.; Inlet Tube; Cut-to-fit  
 Ford; F Pickup; 1996-1990; V-8 7.5 Eng.; Outlet Tube; Cut-to-fit  
 Ford; Ltd Crown Victoria; 1991-1988; V-8 5.0 Eng.; Inlet Tube; Cut-to-fit  
 Ford; Ltd Crown Victoria; 1991-1988; V-8 5.0 Eng.; Outlet Tube; Cut-to-fit  
 Ford; Ltd Crown Victoria; 1991-1988; V-8 5.8 Eng.; Inlet Tube; Cut-to-fit  
 Ford; Ltd Crown Victoria; 1991-1988; V-8 5.8 Eng.; Outlet Tube; Cut-to-fit  
 Ford; Mustang; 1993; 4-Cyl. 2.3 Eng.; Inlet Tube; W/AOD Trans; Cut-to-fit  
 Ford; Mustang; 1993; 4-Cyl. 2.3 Eng.; Outlet Tube; W/AOD Trans; Cut-to-fit  
 Ford; Mustang; 1992-1990; 4-Cyl. 2.3 Eng.; Inlet Tube; W/AOD Trans; Cut-to-fit  
 Ford; Mustang; 1992-1990; 4-Cyl. 2.3 Eng.; Outlet Tube; W/AOD Trans; Cut-to-fit  
 Ford; Mustang; 1989-1988; 4-Cyl. 2.3 Eng.; Inlet Tube; W/AOD Trans; Cut-to-fit  
 Ford; Mustang; 1989-1988; 4-Cyl. 2.3 Eng.; Outlet Tube; W/AOD Trans; Cut-to-fit  
 Ford; Mustang; 1996-1994; V-6 3.8 Eng.; Inlet Tube; Cut-to-fit  
 Ford; Mustang; 1996-1994; V-6 3.8 Eng.; Outlet Tube; Cut-to-fit  
 Ford; Mustang; 1995-1994; V-8 5.0 Eng.; Inlet Tube; Cut-to-fit  
 Ford; Mustang; 1995-1994; V-8 5.0 Eng.; Outlet Tube; Cut-to-fit  
 Ford; Mustang; 1993; V-8 5.0 Eng.; Inlet Tube; W/AOD Trans; Cut-to-fit  
 Ford; Mustang; 1993; V-8 5.0 Eng.; Outlet Tube; W/AOD Trans; Cut-to-fit  
 Ford; Mustang; 1992-1990; V-8 5.0 Eng.; Inlet Tube; W/AOD Trans; Cut-to-fit  
 Ford; Mustang; 1992-1990; V-8 5.0 Eng.; Outlet Tube; W/AOD Trans; Cut-to-fit  
 Ford; Mustang; 1989; V-8 5.0 Eng.; Inlet Tube; W/AOD Trans; Cut-to-fit  
 Ford; Mustang; 1989; V-8 5.0 Eng.; Outlet Tube; W/AOD Trans; Cut-to-fit  
 Ford; Mustang; 1995; V-8 5.8 Eng.; Inlet Tube; Cut-to-fit  
 Ford; Mustang; 1995; V-8 5.8 Eng.; Outlet Tube; Cut-to-fit  
 Ford; Taurus; 1991-1986; 4-Cyl. 2.5 Eng.; Inlet Tube (Upper); Cut-to-fit  
 Ford; Taurus; 1991-1990; 4-Cyl. 2.5 Eng.; Outlet Tube (Lower); Cut-to-fit  
 Ford; Taurus; 1989-1986; 4-Cyl. 2.5 Eng.; Outlet Tube (Lower); W/ATX Trans.; Cut-to-fit  
 Ford; Taurus; 1989-1986; V-6 3.0 Eng.; Inlet Tube (Upper); Cut-to-fit  
 Ford; Taurus; 1989-1986; V-6 3.0 Eng.; Outlet Tube (Lower); W/ATX Trans.; Cut-to-fit  
 Ford; Taurus; 1989-1988; V-6 3.8 Eng.; Inlet Tube (Upper); Cut-to-fit  
 Ford; Taurus; 1989-1988; V-6 3.8 Eng.; Outlet Tube (Lower); W/ATX Trans.; Cut-to-fit  
 Ford; Tempo; 1994-1988; 4-Cyl. 2.3 Eng.; Inlet Tube (Upper); Cut-to-fit  
 Ford; Tempo; 1994-1988; 4-Cyl. 2.3 Eng.; Outlet Tube (Lower); Cut-to-fit  
 Ford; Tempo; 1994-1992; V-6 3.0 Eng.; Inlet Tube (Upper); Cut-to-fit  
 Ford; Tempo; 1994-1992; V-6 3.0 Eng.; Outlet Tube (Lower); Cut-to-fit  
 Ford; Thunderbird; 1988; 4-Cyl. 2.3 Eng.; Inlet Tube; Cut-to-fit  
 Ford; Thunderbird; 1988; 4-Cyl. 2.3 Eng.; Outlet Tube; Cut-to-fit  
 Ford; Thunderbird; 1997-1996; V-6 3.8 Eng.; Inlet (Upper); Cut-to-fit  
 Ford; Thunderbird; 1997-1996; V-6 3.8 Eng.; Outlet (Lower); Cut-to-fit  
 Ford; Thunderbird; 1995-1990; V-6 3.8 Eng.; Inlet (Driver Side); W/Schgr; Cut-to-fit  
 Ford; Thunderbird; 1995-1990; V-6 3.8 Eng.; Outlet (Pass. Side); W/Schgr; Cut-to-fit  
 Ford; Thunderbird; 1989; V-6 3.8 Eng.; Inlet Tube (Upper); Cut-to-fit  
 Ford; Thunderbird; 1989; V-6 3.8 Eng.; Outlet Tube (Lower); Cut-to-fit  
 Ford; Thunderbird; 1988; V-6 3.8 Eng.; Inlet Tube; Cut-to-fit  
 Ford; Thunderbird; 1988; V-6 3.8 Eng.; Outlet Tube; Cut-to-fit  
 Ford; Thunderbird; 1997-1996; V-8 4.6 Eng.; Inlet (Upper); Cut-to-fit  
 Ford; Thunderbird; 1997-1996; V-8 4.6 Eng.; Outlet (Lower); Cut-to-fit  
 Ford; Thunderbird; 1995-1994; V-8 4.6 Eng.; Inlet Tube (Upper); Cut-to-fit  
 Ford; Thunderbird; 1995-1994; V-8 4.6 Eng.; Outlet Tube (Lower); Cut-to-fit

## A63004 - Continued

Ford; Thunderbird; 1988; V-8 5.0 Eng.; Inlet Tube; Cut-to-fit  
 Ford; Thunderbird; 1988; V-8 5.0 Eng.; Outlet Tube; Cut-to-fit  
 GMC; C&K Pickup; 1986-1985; 6-Cyl. 4.8 Eng.; Inlet (Upper); Cut-to-fit  
 GMC; C&K Pickup; 1986-1985; 6-Cyl. 4.8 Eng.; Outlet (Lower); Cut-to-fit  
 GMC; C&K Pickup; 1995-1994; V-6 4.3 Eng.; Inlet (Upper); Cut-to-fit  
 GMC; C&K Pickup; 1995-1994; V-6 4.3 Eng.; Outlet (Lower); Cut-to-fit  
 GMC; C&K Pickup; 1993; V-6 4.3 Eng.; Inlet (Lower); Cut-to-fit  
 GMC; C&K Pickup; 1993; V-6 4.3 Eng.; Outlet (Upper); Cut-to-fit  
 GMC; C&K Pickup; 1992-1988; V-6 4.3 Eng.; Inlet (Upper); Cut-to-fit  
 GMC; C&K Pickup; 1992-1988; V-6 4.3 Eng.; Outlet (Lower); Cut-to-fit  
 GMC; C&K Pickup; 1986-1985; V-6 4.3 Eng.; Inlet (Upper); Cut-to-fit  
 GMC; C&K Pickup; 1986-1985; V-6 4.3 Eng.; Outlet (Lower); Cut-to-fit  
 GMC; C&K Pickup; 1995-1994; V-8 5.0 Eng.; Inlet (Upper); Cut-to-fit  
 GMC; C&K Pickup; 1995-1994; V-8 5.0 Eng.; Outlet (Lower); Cut-to-fit  
 GMC; C&K Pickup; 1993; V-8 5.0 Eng.; Inlet (Lower); Cut-to-fit  
 GMC; C&K Pickup; 1993; V-8 5.0 Eng.; Outlet (Upper); Cut-to-fit  
 GMC; C&K Pickup; 1992-1988; V-8 5.0 Eng.; Inlet (Upper); Cut-to-fit  
 GMC; C&K Pickup; 1992-1988; V-8 5.0 Eng.; Outlet (Lower); Cut-to-fit  
 GMC; C&K Pickup; 1986-1985; V-8 5.0 Eng.; Inlet (Lower); Cut-to-fit  
 GMC; C&K Pickup; 1986-1985; V-8 5.0 Eng.; Outlet (Lower); Cut-to-fit  
 GMC; C&K Pickup; 1995-1993; V-8 5.7 Eng.; Inlet (Upper); W/Aux. Cooler; Cut-to-fit  
 GMC; C&K Pickup; 1995-1993; V-8 5.7 Eng.; Outlet (Lower); W/O Aux. Cooler; Cut-to-fit  
 GMC; C&K Pickup; 1995-1993; V-8 5.7 Eng.; Outlet (Lower); W/O Aux. Cooler; Cut-to-fit  
 GMC; C&K Pickup; 1992-1988; V-8 5.7 Eng.; Inlet (Upper); Cut-to-fit  
 GMC; C&K Pickup; 1992-1988; V-8 5.7 Eng.; Outlet (Lower); Cut-to-fit  
 GMC; C&K Pickup; 1986-1985; V-8 5.7 Eng.; Inlet (Upper); Cut-to-fit  
 GMC; C&K Pickup; 1986-1985; V-8 5.7 Eng.; Outlet (Lower); Cut-to-fit  
 GMC; C&K Pickup; 1993-1988; V-8 6.2 Diesel Eng.; Inlet (Upper); Cut-to-fit  
 GMC; C&K Pickup; 1993-1988; V-8 6.2 Diesel Eng.; Outlet (Lower); Cut-to-fit  
 GMC; C&K Pickup; 1986-1985; V-8 6.2 Diesel Eng.; Inlet (Upper); Cut-to-fit  
 GMC; C&K Pickup; 1986-1985; V-8 6.2 Diesel Eng.; Outlet (Lower); Cut-to-fit  
 GMC; C&K Pickup; 1995-1992; V-8 6.5 Diesel Eng.; Inlet (Upper); Cut-to-fit  
 GMC; C&K Pickup; 1992; V-8 6.5 Diesel Eng.; Outlet (Lower); Cut-to-fit  
 GMC; C&K Pickup; 1995-1988; V-8 7.4 Eng.; Inlet (Upper); Cut-to-fit  
 GMC; C&K Pickup; 1992-1988; V-8 7.4 Eng.; Outlet (Lower); Cut-to-fit  
 GMC; C&K Pickup; 1986-1985; V-8 7.4 Eng.; Inlet (Upper); Cut-to-fit  
 GMC; C&K Pickup; 1986-1985; V-8 7.4 Eng.; Outlet (Lower); Cut-to-fit  
 GMC; Caballero; 1987-1986; V-6 4.3 Eng.; Inlet (Lower); Cut-to-fit  
 GMC; Caballero; 1987-1986; V-6 4.3 Eng.; Outlet (Upper); Cut-to-fit  
 GMC; Caballero; 1987-1986; V-8 5.0 Eng.; Inlet (Lower); Cut-to-fit  
 GMC; Caballero; 1987-1986; V-8 5.0 Eng.; Outlet (Upper); Cut-to-fit  
 GMC; G Van; 1996-1986; V-6 4.3 Eng.; Inlet (Upper); Cut-to-fit  
 GMC; G Van; 1996-1994; V-6 4.3 Eng.; Outlet (Lower); W/O Aux. Cooler; Cut-to-fit  
 GMC; G Van; 1995-1994; V-6 4.3 Eng.; Outlet (Lower); W/Aux. Cooler; W/17-Bolt Trans. Pan (MT1); Cut-to-fit  
 GMC; G Van; 1993-1986; V-6 4.3 Eng.; Outlet (Lower); Cut-to-fit  
 GMC; G Van; 1995-1986; V-8 5.0 Eng.; Inlet (Upper); Cut-to-fit  
 GMC; G Van; 1995-1994; V-8 5.0 Eng.; Outlet (Lower); W/Aux. Cooler; W/17-Bolt Trans. Pan (MT1); Cut-to-fit  
 GMC; G Van; 1995-1994; V-8 5.0 Eng.; Outlet (Lower); W/O Aux. Cooler; Cut-to-fit  
 GMC; G Van; 1993-1986; V-8 5.0 Eng.; Outlet (Lower); Cut-to-fit  
 GMC; G Van; 1996-1986; V-8 5.7 Eng.; Inlet (Upper); Cut-to-fit  
 GMC; G Van; 1996-1994; V-8 5.7 Eng.; Outlet (Lower); W/O Aux. Cooler; Cut-to-fit  
 GMC; G Van; 1995-1994; V-8 5.7 Eng.; Outlet (Lower); W/Aux. Cooler; W/17-Bolt Trans. Pan (MT1); Cut-to-fit  
 GMC; G Van; 1993-1986; V-8 5.7 Eng.; Outlet (Lower); Cut-to-fit  
 GMC; G Van; 1993-1986; V-8 6.2 Diesel Eng.; Inlet (Upper); Cut-to-fit  
 GMC; G Van; 1993-1986; V-8 6.2 Diesel Eng.; Outlet (Lower); Cut-to-fit  
 GMC; G Van; 1996-1994; V-8 6.5 Diesel Eng.; Inlet (Upper); Cut-to-fit  
 GMC; G Van; 1996-1994; V-8 6.5 Diesel Eng.; Outlet (Lower); W/O Aux. Cooler; Cut-to-fit  
 GMC; G Van; 1995-1994; V-8 6.5 Diesel Eng.; Outlet (Lower); W/Aux. Cooler; W/17-Bolt Trans. Pan (MT1); Cut-to-fit  
 GMC; G Van; 1996-1988; V-8 7.4 Eng.; Inlet (Upper); Cut-to-fit  
 GMC; G Van; 1996-1994; V-8 7.4 Eng.; Outlet (Lower); W/O Aux. Cooler; Cut-to-fit  
 GMC; G Van; 1993-1988; V-8 7.4 Eng.; Outlet (Lower); Cut-to-fit  
 GMC; Jimmy; 1995-1992; V-6 4.3 Eng.; Inlet Tube (Lower); Cut-to-fit  
 GMC; Jimmy; 1995-1992; V-6 4.3 Eng.; Outlet Tube (Upper); Cut-to-fit  
 GMC; Jimmy Compact; 1988-1987; 4-Cyl. 2.5 Eng.; Inlet Tube; Cut-to-fit  
 GMC; Jimmy Compact; 1988-1987; 4-Cyl. 2.5 Eng.; Outlet Tube; Cut-to-fit  
 GMC; Jimmy Compact; 1989-1987; V-6 2.8 Eng.; Inlet Tube; Cut-to-fit

Product Section

Troubleshooting

EOC Applications

TOC Applications

Numerical Listing

Manufacturers' Part Numbers

End Fittings

Illustrations

# Numerical Listing - Oil Cooler Assemblies & End Fittings

## A63004 - Continued

GMC; Jimmy Compact; 1989-1987; V-6 2.8 Eng.; Outlet Tube; Cut-to-fit  
 GMC; Jimmy Compact; 1991-1988; V-6 4.3 Eng.; Inlet Tube; Cut-to-fit  
 GMC; Jimmy Compact; 1991-1988; V-6 4.3 Eng.; Outlet Tube; Cut-to-fit  
 GMC; Jimmy Full Size; 1987; V-8 5.0 Eng.; Inlet Tube; Cut-to-fit  
 GMC; Jimmy Full Size; 1987; V-8 5.0 Eng.; Outlet Tube; Cut-to-fit  
 GMC; Jimmy Full Size; 1991-1987; V-8 5.7 Eng.; Inlet Tube; Cut-to-fit  
 GMC; Jimmy Full Size; 1991-1987; V-8 5.7 Eng.; Outlet Tube; Cut-to-fit  
 GMC; Jimmy Full Size; 1991-1987; V-8 6.2 Diesel Eng.; Inlet Tube; Cut-to-fit  
 GMC; Jimmy Full Size; 1991-1987; V-8 6.2 Diesel Eng.; Outlet Tube; Cut-to-fit  
 GMC; R&V Pickup; 1988-1987; 6-Cyl. 4.8 Eng.; Inlet (Upper); Cut-to-fit  
 GMC; R&V Pickup; 1988-1987; 6-Cyl. 4.8 Eng.; Outlet (Lower); Cut-to-fit  
 GMC; R&V Pickup; 1987; V-6 4.3 Eng.; Inlet (Upper); Cut-to-fit  
 GMC; R&V Pickup; 1987; V-6 4.3 Eng.; Outlet (Lower); Cut-to-fit  
 GMC; R&V Pickup; 1987; V-8 5.0 Eng.; Inlet (Upper); Cut-to-fit  
 GMC; R&V Pickup; 1987; V-8 5.0 Eng.; Outlet (Lower); Cut-to-fit  
 GMC; R&V Pickup; 1991-1987; V-8 5.7 Eng.; Inlet (Upper); Cut-to-fit  
 GMC; R&V Pickup; 1991-1987; V-8 5.7 Eng.; Outlet (Lower); Cut-to-fit  
 GMC; R&V Pickup; 1991-1987; V-8 6.2 Diesel Eng.; Inlet (Upper); Cut-to-fit  
 GMC; R&V Pickup; 1991-1987; V-8 6.2 Diesel Eng.; Outlet (Lower); Cut-to-fit  
 GMC; R&V Pickup; 1991-1987; V-8 7.4 Eng.; Inlet (Upper); Cut-to-fit  
 GMC; R&V Pickup; 1991-1987; V-8 7.4 Eng.; Outlet (Lower); Cut-to-fit  
 GMC; S Pickup; 1990-1986; 4-Cyl. 2.5 Eng.; Inlet (Lower); Cut-to-fit  
 GMC; S Pickup; 1990-1986; 4-Cyl. 2.5 Eng.; Outlet (Upper); Cut-to-fit  
 GMC; S Pickup; 1990-1986; V-6 2.8 Eng.; Inlet (Lower); Cut-to-fit  
 GMC; S Pickup; 1990-1986; V-6 2.8 Eng.; Outlet (Upper); Cut-to-fit  
 GMC; S Pickup; 1990-1988; V-6 4.3 Eng.; Inlet (Lower); Cut-to-fit  
 GMC; S Pickup; 1990-1988; V-6 4.3 Eng.; Outlet (Upper); Cut-to-fit  
 GMC; Safari; 1990-1985; 4-Cyl. 2.5 Eng.; Inlet Tube (Upper); Cut-to-fit  
 GMC; Safari; 1990-1985; 4-Cyl. 2.5 Eng.; Outlet Tube (Lower); Cut-to-fit  
 GMC; Safari; 1994-1985; V-6 4.3 Eng.; Inlet Tube (Upper); Cut-to-fit  
 GMC; Safari; 1994-1985; V-6 4.3 Eng.; Outlet Tube (Lower); Cut-to-fit  
 GMC; Sonoma; 1997-1994; 4-Cyl. 2.2 Eng.; Inlet (Lower); Cut-to-fit  
 GMC; Sonoma; 1997-1994; 4-Cyl. 2.2 Eng.; Outlet (Upper); Cut-to-fit  
 GMC; Sonoma; 1993-1991; 4-Cyl. 2.5 Eng.; Inlet (Lower); Cut-to-fit  
 GMC; Sonoma; 1993-1991; 4-Cyl. 2.5 Eng.; Outlet (Upper); Cut-to-fit  
 GMC; Sonoma; 1993-1991; V-6 2.8 Eng.; Inlet (Lower); Cut-to-fit  
 GMC; Sonoma; 1993-1991; V-6 2.8 Eng.; Outlet (Upper); Cut-to-fit  
 GMC; Sonoma; 1995-1991; V-6 4.3 Eng.; Inlet (Lower); Cut-to-fit  
 GMC; Sonoma; 1995-1991; V-6 4.3 Eng.; Outlet (Upper); Cut-to-fit  
 GMC; Suburban; 1987-1985; V-8 5.0 Eng.; Inlet (Upper); Cut-to-fit  
 GMC; Suburban; 1987-1985; V-8 5.0 Eng.; Outlet (Lower); Cut-to-fit  
 GMC; Suburban; 1995-1993; V-8 5.7 Eng.; Inlet (Upper); W/Aux. Cooler; Cut-to-fit  
 GMC; Suburban; 1995-1993; V-8 5.7 Eng.; Outlet (Lower); W/O Aux. Cooler; Cut-to-fit  
 GMC; Suburban; 1992-1985; V-8 5.7 Eng.; Inlet (Upper); Cut-to-fit  
 GMC; Suburban; 1992-1985; V-8 5.7 Eng.; Outlet (Lower); Cut-to-fit  
 GMC; Suburban; 1991-1985; V-8 6.2 Diesel Eng.; Inlet (Upper); Cut-to-fit  
 GMC; Suburban; 1991-1985; V-8 6.2 Diesel Eng.; Outlet (Lower); Cut-to-fit  
 GMC; Suburban; 1995-1994; V-8 6.5 Diesel Eng.; Inlet (Upper); Cut-to-fit  
 GMC; Suburban; 1995-1985; V-8 7.4 Eng.; Inlet (Upper); Cut-to-fit  
 GMC; Suburban; 1992-1985; V-8 7.4 Eng.; Outlet (Lower); Cut-to-fit  
 GMC; Syclyone; 1992-1991; V-6 4.3 Eng.; Inlet (Lower); Cut-to-fit  
 GMC; Syclyone; 1992-1991; V-6 4.3 Eng.; Outlet (Upper); Cut-to-fit  
 GMC; Typhoon; 1993-1992; V-6 4.3 Eng.; Inlet (Upper); Cut-to-fit  
 GMC; Typhoon; 1993-1992; V-6 4.3 Eng.; Outlet (Upper); Cut-to-fit  
 GMC; Yukon; 1995-1993; V-8 5.7 Eng.; Inlet (Upper); W/Aux. Cooler; Cut-to-fit  
 GMC; Yukon; 1995-1993; V-8 5.7 Eng.; Outlet (Lower); W/O Aux. Cooler; Cut-to-fit  
 GMC; Yukon; 1995-1993; V-8 5.7 Eng.; Outlet (Lower); W/O Aux. Cooler; Cut-to-fit  
 GMC; Yukon; 1992; V-8 5.7 Eng.; Inlet (Upper); Cut-to-fit  
 GMC; Yukon; 1992; V-8 5.7 Eng.; Outlet (Lower); Cut-to-fit  
 GMC; Yukon; 1995-1994; V-8 6.5 Diesel Eng.; Inlet (Upper); Cut-to-fit  
 Jeep; Grand Wagoneer; 1991-1990; V-8 5.9 Eng.; Aux. Cooler Inlet Tube; Cut-to-fit  
 Jeep; Grand Wagoneer; 1991-1990; V-8 5.9 Eng.; Aux. Cooler Outlet Tube; Cut-to-fit  
 Jeep; Wrangler; 1993-1991; 4-Cyl. 2.5 Eng.; Inlet Tube; Cut-to-fit  
 Jeep; Wrangler; 1993-1991; 4-Cyl. 2.5 Eng.; Outlet Tube; Cut-to-fit  
 Jeep; Wrangler; 1990; 4-Cyl. 2.5 Eng.; Outlet Tube (Pass. Side); Cut-to-fit  
 Jeep; Wrangler; 1993-1991; 6-Cyl. 4.0 Eng.; Inlet Tube; Cut-to-fit  
 Jeep; Wrangler; 1993-1991; 6-Cyl. 4.0 Eng.; Outlet Tube; Cut-to-fit  
 Jeep; Wrangler; 1990; 6-Cyl. 4.2 Eng.; Outlet Tube (Pass. Side); Cut-to-fit  
 Linc; Continental; 1989-1988; V-6 3.8 Eng.; Inlet Tube; Cut-to-fit  
 Linc; Continental; 1989-1988; V-6 3.8 Eng.; Outlet Tube; Cut-to-fit

## A63004 - Continued

Linc; Mark VII; 1992-1988; V-8 5.0 Eng.; Inlet Tube; Cut-to-fit  
 Linc; Mark VII; 1992-1988; V-8 5.0 Eng.; Outlet Tube; Cut-to-fit  
 Linc; Mark VIII; 1998-1993; V-8 4.6 Eng.; Inlet Tube; Cut-to-fit  
 Linc; Mark VIII; 1998-1993; V-8 4.6 Eng.; Outlet Tube; Cut-to-fit  
 Linc; Town Car; 1995-1991; V-8 4.6 Eng.; Inlet Tube; Cut-to-fit  
 Linc; Town Car; 1995-1991; V-8 4.6 Eng.; Outlet Tube; Cut-to-fit  
 Linc; Town Car; 1990-1988; V-8 5.0 Eng.; Inlet Tube; Cut-to-fit  
 Linc; Town Car; 1990-1988; V-8 5.0 Eng.; Outlet Tube; Cut-to-fit  
 Merc; Colony Park; 1991-1988; V-8 5.0 Eng.; Inlet Tube; Cut-to-fit  
 Merc; Colony Park; 1991-1988; V-8 5.0 Eng.; Outlet Tube; Cut-to-fit  
 Merc; Cougar; 1997-1996; V-6 3.8 Eng.; Inlet (Upper); Cut-to-fit  
 Merc; Cougar; 1997-1996; V-6 3.8 Eng.; Outlet (Lower); Cut-to-fit  
 Merc; Cougar; 1990; V-6 3.8 Eng.; Inlet (Driver Side); W/Schgr; Cut-to-fit  
 Merc; Cougar; 1990; V-6 3.8 Eng.; Outlet (Pass. Side); W/Schgr; Cut-to-fit  
 Merc; Cougar; 1989; V-6 3.8 Eng.; Inlet Tube (Upper); Cut-to-fit  
 Merc; Cougar; 1989; V-6 3.8 Eng.; Outlet Tube (Lower); Cut-to-fit  
 Merc; Cougar; 1988; V-6 3.8 Eng.; Inlet Tube; Cut-to-fit  
 Merc; Cougar; 1988; V-6 3.8 Eng.; Outlet Tube; Cut-to-fit  
 Merc; Cougar; 1997-1996; V-8 4.6 Eng.; Inlet (Upper); Cut-to-fit  
 Merc; Cougar; 1997-1996; V-8 4.6 Eng.; Outlet (Lower); Cut-to-fit  
 Merc; Cougar; 1995-1994; V-8 4.6 Eng.; Inlet Tube (Upper); Cut-to-fit  
 Merc; Cougar; 1995-1994; V-8 4.6 Eng.; Outlet Tube (Lower); Cut-to-fit  
 Merc; Cougar; 1988; V-8 5.0 Eng.; Inlet Tube; Cut-to-fit  
 Merc; Cougar; 1988; V-8 5.0 Eng.; Outlet Tube; Cut-to-fit  
 Merc; Grand Marquis; 1995-1992; V-8 4.6 Eng.; Inlet Tube; Cut-to-fit  
 Merc; Grand Marquis; 1995-1992; V-8 4.6 Eng.; Outlet Tube; Cut-to-fit  
 Merc; Grand Marquis; 1991-1988; V-8 5.0 Eng.; Inlet Tube; Cut-to-fit  
 Merc; Grand Marquis; 1991-1988; V-8 5.0 Eng.; Outlet Tube; Cut-to-fit  
 Merc; Grand Marquis; 1989-1988; V-8 5.8 (Canada) Eng.; Inlet Tube; Cut-to-fit  
 Merc; Grand Marquis; 1989-1988; V-8 5.8 (Canada) Eng.; Outlet Tube; Cut-to-fit  
 Merc; Sable; 1986; 4-Cyl. 2.5 Eng.; Inlet Tube (Upper); Cut-to-fit  
 Merc; Sable; 1986; 4-Cyl. 2.5 Eng.; Outlet Tube (Lower); W/ATX Trans.; Cut-to-fit  
 Merc; Sable; 1989-1986; V-6 3.0 Eng.; Inlet Tube (Upper); Cut-to-fit  
 Merc; Sable; 1989-1986; V-6 3.0 Eng.; Outlet Tube (Lower); W/ATX Trans.; Cut-to-fit  
 Merc; Sable; 1989-1988; V-6 3.8 Eng.; Inlet Tube (Upper); Cut-to-fit  
 Merc; Sable; 1989-1988; V-6 3.8 Eng.; Outlet Tube (Lower); W/ATX Trans.; Cut-to-fit  
 Merc; Topaz; 1994-1988; 4-Cyl. 2.3 Eng.; Inlet Tube (Upper); Cut-to-fit  
 Merc; Topaz; 1994-1988; 4-Cyl. 2.3 Eng.; Outlet Tube (Lower); Cut-to-fit  
 Merc; Topaz; 1994-1992; V-6 3.0 Eng.; Inlet Tube (Upper); Cut-to-fit  
 Merc; Topaz; 1994-1992; V-6 3.0 Eng.; Outlet Tube (Lower); Cut-to-fit  
 Merc; Tracer; 1989-1988; 4-Cyl. 1.6 Eng.; Inlet Tube; Cut-to-fit  
 Merc; Tracer; 1989-1988; 4-Cyl. 1.6 Eng.; Outlet Tube; Cut-to-fit  
 Olds; Bravada; 1994-1991; V-6 4.3 Eng.; Inlet Tube (Lower); Cut-to-fit  
 Olds; Bravada; 1994-1991; V-6 4.3 Eng.; Outlet Tube (Upper); Cut-to-fit  
 Olds; Custom Cruiser; 1992-1988; V-8 5.0 Eng.; Inlet Tube (Upper); Cut-to-fit  
 Olds; Custom Cruiser; 1992-1988; V-8 5.0 Eng.; Outlet Tube (Lower); Cut-to-fit  
 Olds; Cutlass Ciera; 1996-1993; 4-Cyl. 2.2 Eng.; Inlet Tube (Upper); Cut-to-fit  
 Olds; Cutlass Ciera; 1996-1993; 4-Cyl. 2.2 Eng.; Outlet Tube (Lower); Cut-to-fit  
 Olds; Cutlass Ciera; 1992-1988; 4-Cyl. 2.5 Eng.; Inlet Tube (Upper); Cut-to-fit  
 Olds; Cutlass Ciera; 1992-1988; 4-Cyl. 2.5 Eng.; Outlet Tube (Lower); Cut-to-fit  
 Olds; Cutlass Ciera; 1992-1988; 4-Cyl. 2.5 Eng.; Inlet Tube (Upper); Cut-to-fit  
 Olds; Cutlass Ciera; 1989-1988; V-6 2.8 Eng.; Inlet Tube (Upper); Cut-to-fit  
 Olds; Cutlass Ciera; 1989-1988; V-6 2.8 Eng.; Outlet Tube (Lower); Cut-to-fit  
 Olds; Cutlass Ciera; 1996-1994; V-6 3.1 Eng.; Inlet Tube From Rad (Upper); Cut-to-fit  
 Olds; Cutlass Ciera; 1996-1994; V-6 3.1 Eng.; Outlet Tube From Rad (Lower); Cut-to-fit  
 Olds; Cutlass Ciera; 1993-1989; V-6 3.3 Eng.; Inlet Tube (Upper); Cut-to-fit  
 Olds; Cutlass Ciera; 1993-1989; V-6 3.3 Eng.; Outlet Tube (Lower); Cut-to-fit  
 Olds; Cutlass Ciera; 1988; V-6 3.8 Eng.; Inlet Tube (Upper); Cut-to-fit  
 Olds; Cutlass Ciera; 1988; V-6 3.8 Eng.; Outlet Tube (Lower); Cut-to-fit  
 Olds; Cutlass Cruiser; 1990; 4-Cyl. 2.5 Eng.; Inlet Tube (Upper); Cut-to-fit  
 Olds; Cutlass Cruiser; 1990; 4-Cyl. 2.5 Eng.; Outlet Tube (Lower); Cut-to-fit  
 Olds; Cutlass Cruiser; 1994; V-6 3.1 Eng.; Inlet Tube From Rad (Upper); Cut-to-fit  
 Olds; Cutlass Cruiser; 1994; V-6 3.1 Eng.; Outlet Tube From Rad (Lower); Cut-to-fit  
 Olds; Cutlass Cruiser; 1993-1990; V-6 3.3 Eng.; Inlet Tube (Upper); Cut-to-fit  
 Olds; Cutlass Cruiser; 1993-1990; V-6 3.3 Eng.; Outlet Tube (Lower); Cut-to-fit  
 Olds; Cutlass Supreme; 1991-1990; 4-Cyl. 2.3 Eng.; Aux. Cooler Inlet Tube (Upper); Cut-to-fit

Product Section

Troubleshooting

EOC Applications

TOC Applications

Numerical Listing

Manufacturers' Part Numbers

End Fittings

Illustrations

## Numerical Listing - Oil Cooler Assemblies & End Fittings

### A63004 - Continued

Olds; Cutlass Supreme; 1991-1990; 4-Cyl. 2.3 Eng.; Aux. Cooler Outlet Tube (Lower); Cut-to-fit  
 Olds; Cutlass Supreme; 1991-1990; 4-Cyl. 2.3 Eng.; Inlet Tube To Trans. (Upper); Cut-to-fit  
 Olds; Cutlass Supreme; 1991-1990; 4-Cyl. 2.3 Eng.; Outlet Tube To Trans. (Lower); Cut-to-fit  
 Olds; Cutlass Supreme; 1989; V-6 2.8 Eng.; Aux. Cooler Inlet Tube (Upper); Cut-to-fit  
 Olds; Cutlass Supreme; 1989; V-6 2.8 Eng.; Aux. Cooler Outlet Tube (Lower); Cut-to-fit  
 Olds; Cutlass Supreme; 1989; V-6 2.8 Eng.; Inlet Tube To Trans. (Upper); Cut-to-fit  
 Olds; Cutlass Supreme; 1989; V-6 2.8 Eng.; Outlet Tube To Trans. (Lower); Cut-to-fit  
 Olds; Cutlass Supreme; 1988; V-6 2.8 Eng.; Inlet Tube (Upper); Cut-to-fit  
 Olds; Cutlass Supreme; 1988; V-6 2.8 Eng.; Outlet Tube (Lower); Cut-to-fit  
 Olds; Cutlass Supreme; 1993-1991; V-6 3.1 Eng.; Inlet Tube To Trans. (Upper); W/3-Spd Trans.; Cut-to-fit  
 Olds; Cutlass Supreme; 1993-1991; V-6 3.1 Eng.; Outlet Tube To Trans. (Lower); W/3-Spd Trans.; Cut-to-fit  
 Olds; Cutlass Supreme; 1990-1989; V-6 3.1 Eng.; Aux. Cooler Inlet Tube (Upper); Cut-to-fit  
 Olds; Cutlass Supreme; 1990-1989; V-6 3.1 Eng.; Aux. Cooler Outlet Tube (Lower); Cut-to-fit  
 Olds; Cutlass Supreme; 1990-1989; V-6 3.1 Eng.; Inlet Tube To Trans. (Upper); Cut-to-fit  
 Olds; Cutlass Supreme; 1990-1989; V-6 3.1 Eng.; Outlet Tube To Trans. (Lower); Cut-to-fit  
 Olds; Cutlass Supreme; 1993-1991; V-6 3.4 Eng.; Inlet Tube To Trans. (Upper); W/3-Spd Trans.; Cut-to-fit  
 Olds; Cutlass Supreme; 1993-1991; V-6 3.4 Eng.; Outlet Tube To Trans. (Lower); W/3-Spd Trans.; Cut-to-fit  
 Olds; Cutlass Supreme; 1988; V-8 5.0 Eng.; Inlet Tube (Upper); Cut-to-fit  
 Olds; Cutlass Supreme; 1988; V-8 5.0 Eng.; Outlet Tube (Lower); Cut-to-fit  
 Olds; Silhouette; 1994-1990; V-6 3.1 Eng.; Inlet From Rad (Upper); Cut-to-fit  
 Olds; Silhouette; 1994-1990; V-6 3.1 Eng.; Outlet From Rad (Lower); Cut-to-fit  
 Olds; Silhouette; 1994-1990; V-6 3.1 Eng.; Rad Supply Tube (Upper To Lower); Cut-to-fit  
 Olds; Toronado; 1990-1988; V-6 3.8 Eng.; Aux. Cooler Inlet Tube (Lower); Cut-to-fit  
 Olds; Toronado; 1990-1988; V-6 3.8 Eng.; Aux. Cooler Outlet Tube (Upper); Cut-to-fit  
 Olds; Toronado; 1990-1988; V-6 3.8 Eng.; Outlet Tube (Upper); Cut-to-fit  
 Olds; Toronado; 1987-1986; V-6 3.8 Eng.; Inlet Tube (Lower); Cut-to-fit  
 Olds; Toronado; 1987-1986; V-6 3.8 Eng.; Outlet Tube (Lower); Cut-to-fit  
 Pont; Firebird; 1989-1988; V-6 2.8 Eng.; Inlet (Upper); Cut-to-fit  
 Pont; Firebird; 1989-1988; V-6 2.8 Eng.; Outlet (Lower); Cut-to-fit  
 Pont; Firebird; 1992-1990; V-6 3.1 Eng.; Inlet (Upper); Cut-to-fit  
 Pont; Firebird; 1992-1990; V-6 3.1 Eng.; Outlet (Lower); Cut-to-fit  
 Pont; Firebird; 1995-1993; V-6 3.4 Eng.; Inlet Tube To Trans. (Upper); Cut-to-fit  
 Pont; Firebird; 1995-1993; V-6 3.4 Eng.; Outlet Tube From Rad (Lower); Cut-to-fit  
 Pont; Firebird; 1995-1993; V-6 3.4 Eng.; Outlet Tube To Trans. (Lower); Cut-to-fit  
 Pont; Firebird; 1997-1995; V-6 3.8 Eng.; Inlet Tube To Trans. (Upper); Cut-to-fit  
 Pont; Firebird; 1997-1995; V-6 3.8 Eng.; Outlet Tube From Rad (Lower); Cut-to-fit  
 Pont; Firebird; 1997-1995; V-6 3.8 Eng.; Outlet Tube To Trans. (Lower); Cut-to-fit  
 Pont; Firebird; 1992-1988; V-8 5.0 Eng.; Inlet (Upper); Cut-to-fit  
 Pont; Firebird; 1992-1988; V-8 5.0 Eng.; Outlet (Lower); Cut-to-fit  
 Pont; Firebird; 1997-1993; V-8 5.7 Eng.; Inlet Tube To Trans. (Upper); Cut-to-fit  
 Pont; Firebird; 1997-1993; V-8 5.7 Eng.; Outlet Tube From Rad (Lower); Cut-to-fit  
 Pont; Firebird; 1997-1993; V-8 5.7 Eng.; Outlet Tube To Trans. (Lower); Cut-to-fit  
 Pont; Firebird; 1992-1988; V-8 5.7 Eng.; Inlet (Upper); Cut-to-fit  
 Pont; Firebird; 1992-1988; V-8 5.7 Eng.; Outlet (Lower); Cut-to-fit  
 Pont; Grand Prix; 1991-1990; 4-Cyl. 2.3 Eng.; Aux. Cooler Inlet Tube (Upper); Cut-to-fit  
 Pont; Grand Prix; 1991-1990; 4-Cyl. 2.3 Eng.; Aux. Cooler Outlet Tube (Lower); Cut-to-fit  
 Pont; Grand Prix; 1991-1990; 4-Cyl. 2.3 Eng.; Inlet Tube To Trans. (Upper); Cut-to-fit  
 Pont; Grand Prix; 1991-1990; 4-Cyl. 2.3 Eng.; Outlet Tube To Trans. (Lower); Cut-to-fit

### A63004 - Continued

Pont; Grand Prix; 1989-1988; V-6 2.8 Eng.; Inlet Tube From Rad (Upper); Cut-to-fit  
 Pont; Grand Prix; 1989-1988; V-6 2.8 Eng.; Outlet Tube From Rad (Lower); Cut-to-fit  
 Pont; Grand Prix; 1989-1988; V-6 2.8 Eng.; Outlet Tube To Trans. (Lower); Cut-to-fit  
 Pont; Grand Prix; 1993-1991; V-6 3.1 Eng.; Inlet Tube To Trans. (Upper); W/3-Spd Trans.; Cut-to-fit  
 Pont; Grand Prix; 1993-1991; V-6 3.1 Eng.; Outlet Tube To Trans. (Lower); W/3-Spd Trans.; Cut-to-fit  
 Pont; Grand Prix; 1990-1989; V-6 3.1 Eng.; Inlet Tube From Rad (Upper); Cut-to-fit  
 Pont; Grand Prix; 1990-1989; V-6 3.1 Eng.; Inlet Tube To Trans. (Upper); W/Turbo; Cut-to-fit  
 Pont; Grand Prix; 1990-1989; V-6 3.1 Eng.; Outlet Tube From Rad (Lower); Cut-to-fit  
 Pont; Grand Prix; 1990-1989; V-6 3.1 Eng.; Outlet Tube To Trans. (Lower); W/O Turbo; Cut-to-fit  
 Pont; Grand Prix; 1991; V-6 3.4 Eng.; Inlet Tube To Trans. (Upper); W/3-Spd Trans.; Cut-to-fit  
 Pont; Grand Prix; 1991; V-6 3.4 Eng.; Outlet Tube To Trans. (Lower); W/3-Spd Trans.; Cut-to-fit  
 Pont; Trans Sport; 1995-1990; V-6 3.1 Eng.; Inlet Tube From Rad (Upper); Cut-to-fit  
 Pont; Trans Sport; 1995-1990; V-6 3.1 Eng.; Outlet Tube From Rad (Lower); Cut-to-fit  
 Pont; Trans Sport; 1995-1990; V-6 3.1 Eng.; Rad Supply Tube (Upper To Lower); Cut-to-fit  
 Pont; 6000; 1991-1985; 4-Cyl. 2.5 Eng.; Inlet Tube (Upper); Cut-to-fit  
 Pont; 6000; 1991-1985; 4-Cyl. 2.5 Eng.; Outlet Tube (Lower); Cut-to-fit  
 Pont; 6000; 1989-1985; V-6 2.8 Eng.; Inlet Tube (Upper); Cut-to-fit  
 Pont; 6000; 1989-1985; V-6 2.8 Eng.; Outlet Tube (Lower); Cut-to-fit  
 Pont; 6000; 1991-1988; V-6 3.1 Eng.; Inlet Tube (Upper); Cut-to-fit  
 Pont; 6000; 1991-1988; V-6 3.1 Eng.; Outlet Tube (Lower); Cut-to-fit

### A63005

Buick; Regal; 1993-1992; V-6 3.1 Eng.; Inlet Tube From Rad (Upper); Cut-to-fit  
 Buick; Regal; 1993-1992; V-6 3.1 Eng.; Outlet Tube From Rad (Lower); Cut-to-fit  
 Buick; Regal; 1991; V-6 3.1 Eng.; Inlet Tube From Rad (Upper); W/3/8" Tubing; Cut-to-fit  
 Buick; Regal; 1991; V-6 3.1 Eng.; Outlet Tube From Rad (Lower); W/3/8" Tubing; Cut-to-fit  
 Buick; Regal; 1993-1990; V-6 3.8 Eng.; Inlet Tube From Rad (Upper); Cut-to-fit  
 Buick; Regal; 1993-1990; V-6 3.8 Eng.; Outlet Tube From Rad (Lower); Cut-to-fit  
 Buick; Roadmaster; 1996-1994; V-8 5.7 Eng.; Rad Supply Tube (Upper To Lower); W/Aux. Cooler; Cut-to-fit  
 Cad; Escalade; 2000-1999; V-8 5.7 Eng.; Inlet Tube (Upper); W/Aux. Cooler; Service Item;; Cut-to-fit  
 Chev; C&K Pickup; 1997-1996; V-6 4.3 Eng.; Inlet Tube (Upper); Service Item;; Cut-to-fit  
 Chev; C&K Pickup; 1997-1996; V-6 4.3 Eng.; Outlet Tube (Lower); Service Item;; Cut-to-fit  
 Chev; C&K Pickup; 1997-1996; V-8 5.0 Eng.; Inlet Tube (Upper); Service Item;; Cut-to-fit  
 Chev; C&K Pickup; 1997-1996; V-8 5.0 Eng.; Outlet Tube (Lower); Service Item;; Cut-to-fit  
 Chev; C&K Pickup; 2000-1998; V-8 5.7 Eng.; Inlet Tube (Upper); W/Aux. Cooler; Service Item;; Cut-to-fit  
 Chev; C&K Pickup; 1997-1996; V-8 5.7 Eng.; Inlet Tube (Upper); Service Item;; Cut-to-fit  
 Chev; C&K Pickup; 2002-1996; V-8 6.5 Diesel Eng.; Inlet Tube (Upper); Service Item;; Cut-to-fit  
 Chev; C&K Pickup; 1996; V-8 6.5 Diesel Eng.; Outlet Tube (Lower); W/O Aux. Cooler; Service Item;; Cut-to-fit  
 Chev; C&K Pickup; 2000-1996; V-8 7.4 Eng.; Inlet Tube (Upper); Service Item;; Cut-to-fit  
 Chev; C&K Pickup; 2002-2001; V-8 8.1 Eng.; Inlet Tube (Upper); Service Item;; Cut-to-fit  
 Chev; Caprice; 1996-1994; V-8 4.3 Eng.; Rad Supply Tube (Upper To Lower); W/Aux. Cooler; Cut-to-fit  
 Chev; Caprice; 1996-1994; V-8 5.7 Eng.; Rad Supply Tube (Upper To Lower); W/Aux. Cooler; Cut-to-fit  
 Chev; Corvette; 2003-1997; V-8 5.7 Eng.; Inlet Tube To Trans. (Upper); Cut-to-fit  
 Chev; Corvette; 2003-1997; V-8 5.7 Eng.; Outlet Tube To Trans. (Lower); Cut-to-fit  
 Chev; Impala SS; 1996-1994; V-8 5.7 Eng.; Rad Supply Tube (Upper To Lower); W/Aux. Cooler; Cut-to-fit

## Numerical Listing - Oil Cooler Assemblies & End Fittings

### A63005 - Continued

Chev; Lumina; 1993-1991; V-6 3.1 Eng.; Inlet Tube From Rad (Upper); W/4-Spd Trans.; Cut-to-fit  
 Chev; Lumina; 1993-1991; V-6 3.1 Eng.; Outlet Tube From Rad (Lower); W/4-Spd Trans.; Cut-to-fit  
 Chev; Lumina; 1993; V-6 3.4 Eng.; Inlet From Rad (Upper); W/4-Spd Trans.; Cut-to-fit  
 Chev; Lumina; 1993; V-6 3.4 Eng.; Outlet From Rad (Lower); W/4-Spd Trans.; Cut-to-fit  
 Chev; Lumina; 1992-1991; V-6 3.4 Eng.; Inlet Tube From Rad (Upper); W/4-Spd Trans.; Cut-to-fit  
 Chev; Lumina; 1992-1991; V-6 3.4 Eng.; Outlet Tube From Rad (Lower); W/4-Spd Trans.; Cut-to-fit  
 Chev; Lumina APV; 1995-1992; V-6 3.8 Eng.; Outlet From Rad (Lower); W/Aux. Cooler; Cut-to-fit  
 Chev; Silverado Pickup; 1999; V-8 6.5 Diesel Eng.; Inlet Tube (Upper); Service Item;; Cut-to-fit  
 Chev; Suburban; 1999-1996; V-8 5.7 Eng.; Inlet Tube (Upper); Service Item;; Cut-to-fit  
 Chev; Suburban; 1999-1996; V-8 6.5 Diesel Eng.; Inlet Tube (Upper); Service Item;; Cut-to-fit  
 Chev; Suburban; 1999-1996; V-8 7.4 Eng.; Inlet Tube (Upper); Service Item;; Cut-to-fit  
 Chev; Tahoe; 2000-1996; V-8 5.7 Eng.; Inlet Tube (Upper); Service Item;; Cut-to-fit  
 Chev; Tahoe; 1999-1996; V-8 6.5 Diesel Eng.; Inlet Tube (Upper); Service Item;; Cut-to-fit  
 Dodge; B Van; 1993-1990; V-6 3.9 Eng.; Inlet Tube; Cut-to-fit  
 Dodge; B Van; 1993-1990; V-6 3.9 Eng.; Outlet Tube; Cut-to-fit  
 Dodge; B Van; 1993-1990; V-8 5.2 Eng.; Inlet Tube; Cut-to-fit  
 Dodge; B Van; 1993-1990; V-8 5.2 Eng.; Outlet Tube; Cut-to-fit  
 Dodge; B Van; 1993-1990; V-8 5.9 Eng.; Inlet Tube; Cut-to-fit  
 Dodge; B Van; 1993-1990; V-8 5.9 Eng.; Outlet Tube; Cut-to-fit  
 Dodge; D & W Pickup; 1993-1990; V-6 3.9 Eng.; Inlet Tube (Pass. Side); Cut-to-fit  
 Dodge; D & W Pickup; 1993-1990; V-6 3.9 Eng.; Outlet Tube (Driver Side); Cut-to-fit  
 Dodge; D & W Pickup; 1993-1990; V-8 5.2 Eng.; Inlet Tube (Pass. Side); Cut-to-fit  
 Dodge; D & W Pickup; 1993-1990; V-8 5.2 Eng.; Outlet Tube (Driver Side); Cut-to-fit  
 Dodge; D & W Pickup; 1993-1990; V-8 5.9 Eng.; Inlet Tube (Pass. Side); Cut-to-fit  
 Dodge; D & W Pickup; 1993-1990; V-8 5.9 Eng.; Outlet Tube (Driver Side); Cut-to-fit  
 Dodge; Dakota; 1993-1990; V-6 3.9 Eng.; Inlet Tube (Pass. Side); Cut-to-fit  
 Dodge; Dakota; 1993-1990; V-6 3.9 Eng.; Outlet Tube (Driver Side); Cut-to-fit  
 Dodge; Dakota; 1993-1990; V-8 5.2 Eng.; Inlet Tube (Pass. Side); Cut-to-fit  
 Dodge; Dakota; 1993-1990; V-8 5.2 Eng.; Outlet Tube (Driver Side); Cut-to-fit  
 Dodge; Monaco; 1992-1990; V-6 3.0 Eng.; Inlet Tube From Rad (Upper); Cut-to-fit  
 Dodge; Monaco; 1992-1990; V-6 3.0 Eng.; Inlet Tube To Trans. (Upper); Cut-to-fit  
 Dodge; Monaco; 1992-1990; V-6 3.0 Eng.; Outlet Tube To Trans. (Lower); Cut-to-fit  
 Dodge; Ramcharger; 1993-1990; V-8 5.2 Eng.; Inlet Tube (Pass. Side); Cut-to-fit  
 Dodge; Ramcharger; 1993-1990; V-8 5.2 Eng.; Outlet Tube (Driver Side); Cut-to-fit  
 Dodge; Ramcharger; 1993-1990; V-8 5.9 Eng.; Inlet Tube (Pass. Side); Cut-to-fit  
 Dodge; Ramcharger; 1993-1990; V-8 5.9 Eng.; Outlet Tube (Driver Side); Cut-to-fit  
 Eagle; Premier; 1992-1988; V-6 3.0 Eng.; Inlet Tube From Rad (Upper); Cut-to-fit  
 Eagle; Premier; 1992-1988; V-6 3.0 Eng.; Inlet Tube To Trans. (Upper); Cut-to-fit  
 Eagle; Premier; 1992-1988; V-6 3.0 Eng.; Outlet Tube To Trans. (Lower); Cut-to-fit  
 Ford; Aerostar; 1997-1987; V-6 3.0 Eng.; Inlet Tube; Cut-to-fit  
 Ford; Aerostar; 1997-1987; V-6 3.0 Eng.; Outlet Tube; Cut-to-fit  
 Ford; Aerostar; 1997-1990; V-6 4.0 Eng.; Inlet Tube; Cut-to-fit  
 Ford; Aerostar; 1997-1990; V-6 4.0 Eng.; Outlet Tube; Cut-to-fit  
 Ford; Bronco Compact; 1990-1988; V-6 2.9 Eng.; Inlet Tube; Cut-to-fit  
 Ford; Bronco Compact; 1990-1988; V-6 2.9 Eng.; Outlet Tube; Cut-to-fit  
 Ford; Explorer; 1996-1991; V-6 4.0 Eng.; Inlet Tube; Cut-to-fit  
 Ford; Explorer; 1996-1991; V-6 4.0 Eng.; Outlet Tube; Cut-to-fit  
 Ford; Mustang; 1993-1988; 4-Cyl. 2.3 Eng.; Inlet Tube; W/4-Spd Trans.; Cut-to-fit  
 Ford; Mustang; 1993-1988; 4-Cyl. 2.3 Eng.; Outlet Tube; W/4-Spd Trans.; Cut-to-fit

### A63005 - Continued

Ford; Mustang; 1993-1989; V-8 5.0 Eng.; Inlet Tube; W/4-Spd Trans.; Cut-to-fit  
 Ford; Mustang; 1993-1989; V-8 5.0 Eng.; Outlet Tube; W/4-Spd Trans.; Cut-to-fit  
 Ford; Ranger; 1988; 4-Cyl. 2.0 Eng.; Inlet Tube; Cut-to-fit  
 Ford; Ranger; 1988; 4-Cyl. 2.0 Eng.; Outlet Tube; Cut-to-fit  
 Ford; Ranger; 1997-1988; 4-Cyl. 2.3 Eng.; Inlet Tube; Cut-to-fit  
 Ford; Ranger; 1997-1988; 4-Cyl. 2.3 Eng.; Outlet Tube; Cut-to-fit  
 Ford; Ranger; 1992-1988; V-6 2.9 Eng.; Inlet Tube; Cut-to-fit  
 Ford; Ranger; 1992-1988; V-6 2.9 Eng.; Outlet Tube; Cut-to-fit  
 Ford; Ranger; 1997-1991; V-6 3.0 Eng.; Inlet Tube; Cut-to-fit  
 Ford; Ranger; 1997-1991; V-6 3.0 Eng.; Outlet Tube; Cut-to-fit  
 Ford; Ranger; 1997-1990; V-6 4.0 Eng.; Inlet Tube; Cut-to-fit  
 Ford; Ranger; 1997-1990; V-6 4.0 Eng.; Outlet Tube; Cut-to-fit  
 GMC; C&K Pickup; 1997-1996; V-6 4.3 Eng.; Inlet Tube (Upper); Service Item;; Cut-to-fit  
 GMC; C&K Pickup; 1997-1996; V-6 4.3 Eng.; Outlet Tube (Lower); Service Item;; Cut-to-fit  
 GMC; C&K Pickup; 1997-1996; V-8 5.0 Eng.; Inlet Tube (Upper); Service Item;; Cut-to-fit  
 GMC; C&K Pickup; 1997-1996; V-8 5.0 Eng.; Outlet Tube (Lower); Service Item;; Cut-to-fit  
 GMC; C&K Pickup; 2000-1998; V-8 5.7 Eng.; Inlet Tube (Upper); W/Aux. Cooler; Service Item;; Cut-to-fit  
 GMC; C&K Pickup; 1997-1996; V-8 5.7 Eng.; Inlet Tube (Upper); Service Item;; Cut-to-fit  
 GMC; C&K Pickup; 2002-1996; V-8 6.5 Diesel Eng.; Inlet Tube (Upper); Service Item;; Cut-to-fit  
 GMC; C&K Pickup; 1996; V-8 6.5 Diesel Eng.; Outlet Tube (Lower); W/O Aux. Cooler; Service Item;; Cut-to-fit  
 GMC; C&K Pickup; 2000-1996; V-8 7.4 Eng.; Inlet Tube (Upper); Service Item;; Cut-to-fit  
 GMC; C&K Pickup; 2002-2001; V-8 8.1 Eng.; Inlet Tube (Upper); Service Item;; Cut-to-fit  
 GMC; Sierra Pickup; 1999; V-8 6.5 Diesel Eng.; Inlet Tube (Upper); Service Item;; Cut-to-fit  
 GMC; Suburban; 1999-1996; V-8 5.7 Eng.; Inlet Tube (Upper); Service Item;; Cut-to-fit  
 GMC; Suburban; 1999-1996; V-8 6.5 Diesel Eng.; Inlet Tube (Upper); Service Item;; Cut-to-fit  
 GMC; Suburban; 1999-1996; V-8 7.4 Eng.; Inlet Tube (Upper); Service Item;; Cut-to-fit  
 GMC; Yukon; 2000-1998; V-8 5.7 Eng.; Inlet Tube (Upper); W/Aux. Cooler; Service Item;; Cut-to-fit  
 GMC; Yukon; 1997-1996; V-8 5.7 Eng.; Inlet Tube (Upper); Service Item;; Cut-to-fit  
 GMC; Yukon; 1997-1996; V-8 6.5 Diesel Eng.; Inlet Tube (Upper); Service Item;; Cut-to-fit  
 Jeep; Cherokee; 1993-1988; 4-Cyl. 2.5 Eng.; Inlet Hose (Lower); Cut-to-fit  
 Jeep; Cherokee; 1993-1988; 4-Cyl. 2.5 Eng.; Outlet Hose From Rad (Upper); Cut-to-fit  
 Jeep; Comanche; 1992-1988; 4-Cyl. 2.5 Eng.; Inlet Hose (Lower); Cut-to-fit  
 Jeep; Comanche; 1992-1988; 4-Cyl. 2.5 Eng.; Outlet Hose From Rad (Upper); Cut-to-fit  
 Jeep; Wrangler; 1995-1994; 6-Cyl. 4.0 Eng.; Outlet Tube (Pass. Side) To Trans. (Rear); Service Item; Cut-to-fit  
 Olds; Cutlass Supreme; 1993-1992; V-6 3.1 Eng.; Inlet From Rad (Upper); W/4-Spd Trans.  
 Olds; Cutlass Supreme; 1993-1992; V-6 3.1 Eng.; Outlet From Rad (Lower); W/4-Spd Trans.; Cut-to-fit  
 Olds; Cutlass Supreme; 1991; V-6 3.1 Eng.; Inlet From Rad (Upper); W/4-Spd Trans.; Cut-to-fit  
 Olds; Cutlass Supreme; 1993-1992; V-6 3.4 Eng.; Inlet From Rad (Upper); W/4-Spd Trans.  
 Olds; Cutlass Supreme; 1993-1992; V-6 3.4 Eng.; Outlet From Rad (Lower); W/4-Spd Trans.; Cut-to-fit  
 Olds; Cutlass Supreme; 1991; V-6 3.4 Eng.; Inlet From Rad (Upper); W/4-Spd Trans.; Cut-to-fit  
 Olds; Silhouette; 1995-1992; V-6 3.8 Eng.; Outlet From Rad (Lower); W/Aux. Cooler; Cut-to-fit  
 Pont; Grand Prix; 1993-1991; V-6 3.1 Eng.; Inlet Tube From Rad (Upper); W/4-Spd Trans.; Cut-to-fit  
 Pont; Grand Prix; 1993-1992; V-6 3.1 Eng.; Outlet Tube From Rad (Lower); W/4-Spd Trans.; Cut-to-fit  
 Pont; Grand Prix; 1993-1992; V-6 3.4 Eng.; Inlet Tube From Rad (Upper); Cut-to-fit  
 Pont; Grand Prix; 1993-1992; V-6 3.4 Eng.; Outlet Tube From Rad (Lower); Cut-to-fit  
 Pont; Grand Prix; 1991; V-6 3.4 Eng.; Inlet Tube From Rad (Upper); W/4-Spd Trans.; Cut-to-fit  
 Pont; Trans Sport; 1995-1992; V-6 3.8 Eng.; Outlet Tube From Rad (Lower); W/Aux. Cooler; Cut-to-fit

# Numerical Listing - Oil Cooler Assemblies & End Fittings

## A63006

Buick; Century; 1996-1993; 4-Cyl. 2.2 Eng.; Inlet Fitting To Trans. (Upper)  
 Buick; Century; 1996-1993; 4-Cyl. 2.2 Eng.; Outlet Fitting To Trans. (Lower)  
 Buick; Century; 1992-1988; 4-Cyl. 2.5 Eng.; Inlet Fitting To Trans. (Upper)  
 Buick; Century; 1992-1988; 4-Cyl. 2.5 Eng.; Outlet Fitting To Trans. (Lower)  
 Buick; Century; 1989-1988; V-6 2.8 Eng.; Inlet Fitting To Trans. (Upper)  
 Buick; Century; 1989-1988; V-6 2.8 Eng.; Outlet Fitting To Trans. (Lower); W/3-Spd Trans.  
 Buick; Century; 1993-1989; V-6 3.3 Eng.; Inlet Fitting To Trans. (Upper)  
 Buick; Century; 1993-1992; V-6 3.3 Eng.; Outlet Fitting To Trans. (Lower)  
 Buick; Century; 1991-1989; V-6 3.3 Eng.; Outlet Fitting To Trans. (Lower); W/3-Spd Trans.  
 Buick; Century; 1988; V-6 3.8 Eng.; Inlet Fitting To Trans. (Upper)  
 Buick; Century; 1988; V-6 3.8 Eng.; Outlet Fitting To Trans. (Lower); W/3-Spd Trans.  
 Buick; Electra; 1990-1986; V-6 3.8 Eng.; Inlet Fitting To Trans. (Upper)  
 Buick; Electra; 1989-1986; V-8 5.0 Eng.; Inlet Fitting To Trans. (Upper)  
 Buick; Lesabre; 1990-1986; V-6 3.8 Eng.; Inlet Fitting To Trans. (Upper)  
 Buick; Lesabre; 1990-1986; V-8 5.0 Eng.; Inlet Fitting To Trans. (Upper)  
 Buick; Rainier; 2004; V-8 5.3 Eng.; Outlet Fitting To Trans. (Lower)  
 Buick; Reatta; 1990-1988; V-6 3.8 Eng.; Inlet Fitting To Trans. (Upper)  
 Buick; Reatta; 1990-1988; V-6 3.8 Eng.; Outlet Fitting To Trans. (Lower); W/O Check Ball  
 Buick; Regal; 1989-1988; V-6 2.8 Eng.; Inlet Fitting To Trans. (Upper); 2 Reqd  
 Buick; Regal; 1991; V-6 3.1 Eng.; Inlet Fitting To Trans. (Upper); W/5/16" Tubing; W/O Check Ball  
 Buick; Regal; 1991; V-6 3.1 Eng.; Outlet Fitting To Trans. (Lower); W/5/16" Tubing  
 Buick; Regal; 1990-1989; V-6 3.1 Eng.; Inlet Fitting To Trans. (Upper); 2 Reqd  
 Buick; Regal; 1987-1986; V-6 3.8 Eng.; Inlet Fitting To Trans. (Upper)  
 Buick; Regal; 1987-1986; V-6 3.8 Eng.; Outlet Fitting To Trans. (Lower)  
 Buick; Regal; 1987-1986; V-8 5.0 Eng.; Inlet Fitting To Trans. (Upper)  
 Buick; Regal; 1987-1986; V-8 5.0 Eng.; Outlet Fitting To Trans. (Lower)  
 Buick; Riviera; 1990-1986; V-6 3.8 Eng.; Inlet Fitting To Trans. (Lower); 2 Reqd  
 Buick; Roadmaster; 1991; V-8 5.0 Eng.; Inlet Fitting To Trans. (Upper)  
 Buick; Roadmaster; 1991; V-8 5.0 Eng.; Outlet Fitting To Trans. (Lower)  
 Buick; Roadmaster; 1993-1992; V-8 5.7 Eng.; Inlet Fitting To Trans. (Upper)  
 Buick; Roadmaster; 1993-1992; V-8 5.7 Eng.; Outlet Fitting To Trans. (Lower)  
 Buick; Skyhawk; 1986-1985; 4-Cyl. 1.8 Eng.; Inlet Fitting To Trans. (Upper)  
 Buick; Skyhawk; 1986-1985; 4-Cyl. 1.8 Eng.; Outlet Fitting To Trans. (Lower)  
 Buick; Skyhawk; 1989-1985; 4-Cyl. 2.0 Eng.; Inlet Fitting To Trans. (Upper)  
 Buick; Skyhawk; 1989-1985; 4-Cyl. 2.0 Eng.; Outlet Fitting To Trans. (Lower)  
 Buick; Skylark; 1995-1994; 4-Cyl. 2.3 Eng.; Inlet Fitting To Trans. (Upper); W/3-Spd Trans.  
 Buick; Skylark; 1995-1994; 4-Cyl. 2.3 Eng.; Outlet Fitting To Trans. (Lower); W/3-Spd Trans.  
 Buick; Skylark; 1993-1988; 4-Cyl. 2.3 Eng.; Inlet Fitting To Trans. (Upper)  
 Buick; Skylark; 1993-1988; 4-Cyl. 2.3 Eng.; Outlet Fitting To Trans. (Lower)  
 Buick; Skylark; 1991-1985; 4-Cyl. 2.5 Eng.; Inlet Fitting To Trans. (Upper)  
 Buick; Skylark; 1991-1985; 4-Cyl. 2.5 Eng.; Outlet Fitting To Trans. (Lower)  
 Buick; Skylark; 1985; V-6 2.8 Eng.; Inlet Fitting To Trans. (Upper)  
 Buick; Skylark; 1985; V-6 2.8 Eng.; Outlet Fitting To Trans. (Lower)  
 Buick; Skylark; 1988-1986; V-6 3.0 Eng.; Inlet Fitting To Trans. (Upper)  
 Buick; Skylark; 1988-1986; V-6 3.0 Eng.; Outlet Fitting To Trans. (Lower)  
 Buick; Skylark; 1993-1989; V-6 3.3 Eng.; Inlet Fitting To Trans. (Upper)  
 Buick; Skylark; 1993-1989; V-6 3.3 Eng.; Outlet Fitting To Trans. (Lower)  
 Buick; Somerset; 1987-1986; 4-Cyl. 2.5 Eng.; Inlet Fitting To Trans. (Upper)  
 Buick; Somerset; 1987-1986; 4-Cyl. 2.5 Eng.; Outlet Fitting To Trans. (Lower)  
 Buick; Somerset; 1987-1986; V-6 3.0 Eng.; Inlet Fitting To Trans. (Upper)  
 Buick; Somerset; 1987-1986; V-6 3.0 Eng.; Outlet Fitting To Trans. (Lower)  
 Buick; Somerset Regal; 1985; 4-Cyl. 2.5 Eng.; Inlet Fitting To Trans. (Upper)  
 Buick; Somerset Regal; 1985; 4-Cyl. 2.5 Eng.; Outlet Fitting To Trans. (Lower)  
 Buick; Somerset Regal; 1985; V-6 3.0 Eng.; Inlet Fitting To Trans. (Upper)  
 Buick; Somerset Regal; 1985; V-6 3.0 Eng.; Outlet Fitting To Trans. (Lower)  
 Cad; Allante; 1988-1987; V-8 4.1 Eng.; Inlet Fitting To Trans. (Upper)

## A63006 - Continued

Cad; Allante; 1988-1987; V-8 4.1 Eng.; Outlet Fitting To Trans. (Lower); W/O Check Ball  
 Cad; Allante; 1989; V-8 4.5 Eng.; Inlet Fitting To Trans. (Upper)  
 Cad; Allante; 1989; V-8 4.5 Eng.; Outlet Fitting To Trans. (Lower); W/O Check Ball  
 Cad; Brougham; 1992-1987; V-8 5.0 Eng.; Inlet Fitting To Trans. (Upper); 2 Reqd  
 Cad; Brougham; 1992-1987; V-8 5.0 Eng.; Outlet Fitting To Trans. (Lower)  
 Cad; Brougham; 1992-1990; V-8 5.7 Eng.; Inlet Fitting To Trans. (Upper); 2 Reqd  
 Cad; Brougham; 1991-1990; V-8 5.7 Eng.; Outlet Fitting To Trans. (Lower)  
 Cad; Cimarron; 1986-1985; 4-Cyl. 2.0 Eng.; Inlet Fitting To Trans. (Upper)  
 Cad; Cimarron; 1986-1985; 4-Cyl. 2.0 Eng.; Outlet Fitting To Trans. (Lower)  
 Cad; Cimarron; 1988-1985; V-6 2.8 Eng.; Inlet Fitting To Trans. (Upper)  
 Cad; Cimarron; 1988-1985; V-6 2.8 Eng.; Outlet Fitting To Trans. (Lower)  
 Cad; Deville; 1990-1988; V-8 4.5 Eng.; Inlet Fitting To Trans. (Upper)  
 Cad; Deville; 1995-1994; V-8 4.6 Eng.; Inlet Fitting To Trans. (Upper); 2 Reqd  
 Cad; Eldorado; 1990; V-8 4.5 Eng.; Inlet Fitting To Trans. (Lower)  
 Cad; Eldorado; 1989-1988; V-8 4.5 Eng.; Inlet Fitting To Trans. (Upper)  
 Cad; Eldorado; 1995-1993; V-8 4.6 Eng.; Inlet Fitting To Trans. (Upper); 2 Reqd  
 Cad; Escalade; 2004-2002; V-8 5.3 Eng.; Outlet Fitting To Trans. (Lower)  
 Cad; Escalade; 2004-2002; V-8 6.0 Eng.; Outlet Fitting To Trans. (Lower)  
 Cad; Fleetwood; 1990; V-8 4.5 Eng.; Inlet Fitting To Trans. (Upper)  
 Cad; Fleetwood; 1989-1988; V-8 4.5 Eng.; Inlet Fitting To Trans. (Lower)  
 Cad; Fleetwood; 1993; V-8 5.7 Eng.; Inlet Fitting To Trans. (Upper)  
 Cad; Fleetwood; 1993; V-8 5.7 Eng.; Outlet Fitting To Trans. (Lower)  
 Cad; Seville; 1990; V-8 4.5 Eng.; Inlet Fitting To Trans. (Lower)  
 Cad; Seville; 1989-1988; V-8 4.5 Eng.; Inlet Fitting To Trans. (Upper)  
 Cad; Seville; 1995-1994; V-8 4.6 Eng.; Inlet Fitting To Trans. (Upper); 2 Reqd  
 Chev; Astro; 1990-1985; 4-Cyl. 2.5 Eng.; Connector From Rad; 2 Reqd  
 Chev; Astro; 1990-1985; 4-Cyl. 2.5 Eng.; Inlet Fitting To Trans. (Upper)  
 Chev; Astro; 1990-1985; 4-Cyl. 2.5 Eng.; Outlet Fitting To Trans. (Lower)  
 Chev; Astro; 1995-1985; V-6 4.3 Eng.; Inlet Fitting To Trans. (Upper)  
 Chev; Astro; 1995-1985; V-6 4.3 Eng.; Outlet Fitting To Trans. (Lower)  
 Chev; Astro; 1990; V-6 4.3 Eng.; Connector From Rad; W/RWD; 2 Reqd  
 Chev; Astro; 1989-1985; V-6 4.3 Eng.; Connector From Rad; 2 Reqd  
 Chev; Avalanche; 2003-2002; V-8 5.3 Eng.; Outlet Fitting To Trans. (Lower)  
 Chev; Beretta; 1989-1987; 4-Cyl. 2.0 Eng.; Inlet Fitting To Trans. (Upper)  
 Chev; Beretta; 1989-1987; 4-Cyl. 2.0 Eng.; Outlet Fitting To Trans. (Lower)  
 Chev; Beretta; 1996-1994; 4-Cyl. 2.2 Eng.; Inlet Fitting To Trans. (Upper); 2 Reqd  
 Chev; Beretta; 1996-1994; 4-Cyl. 2.2 Eng.; Outlet Fitting To Trans. (Lower); 2 Reqd  
 Chev; Beretta; 1993-1990; 4-Cyl. 2.2 Eng.; Inlet Fitting To Trans. (Upper)  
 Chev; Beretta; 1993-1990; 4-Cyl. 2.2 Eng.; Outlet Fitting To Trans. (Lower)  
 Chev; Beretta; 1994; 4-Cyl. 2.3 Eng.; Inlet Fitting To Trans. (Upper); W/3-Spd Trans.  
 Chev; Beretta; 1994; 4-Cyl. 2.3 Eng.; Outlet Fitting To Trans. (Lower); W/3-Spd Trans.  
 Chev; Beretta; 1989-1987; V-6 2.8 Eng.; Inlet Fitting To Trans. (Upper)  
 Chev; Beretta; 1989-1987; V-6 2.8 Eng.; Outlet Fitting To Trans. (Lower)  
 Chev; Beretta; 1993-1990; V-6 3.1 Eng.; Inlet Fitting To Trans. (Upper)  
 Chev; Beretta; 1993-1990; V-6 3.1 Eng.; Outlet Fitting To Trans. (Lower)  
 Chev; Blazer; 1995; V-6 4.3 Eng.; Connector From Rad; 2 Reqd  
 Chev; Blazer; 1995; V-6 4.3 Eng.; Inlet Fitting To Trans. (Lower)  
 Chev; Blazer; 1995; V-6 4.3 Eng.; Outlet Fitting To Trans. (Upper)  
 Chev; Blazer Compact; 1988-1987; 4-Cyl. 2.5 Eng.; Inlet Fitting To Trans.  
 Chev; Blazer Compact; 1988-1987; 4-Cyl. 2.5 Eng.; Outlet Fitting To Trans.  
 Chev; Blazer Compact; 1989-1987; V-6 2.8 Eng.; Inlet Fitting To Trans.  
 Chev; Blazer Compact; 1989-1987; V-6 2.8 Eng.; Outlet Fitting To Trans.  
 Chev; Blazer Compact; 1994; V-6 4.3 Eng.; Connector From Rad; 2 Reqd  
 Chev; Blazer Compact; 1994-1993; V-6 4.3 Eng.; Inlet Fitting To Trans. (Lower)  
 Chev; Blazer Compact; 1994-1993; V-6 4.3 Eng.; Outlet Fitting To Trans. (Upper)  
 Chev; Blazer Compact; 1992-1988; V-6 4.3 Eng.; Inlet Fitting To Trans.  
 Chev; Blazer Compact; 1992-1988; V-6 4.3 Eng.; Outlet Fitting To Trans.  
 Chev; Blazer Full Size; 1987; V-8 5.0 Eng.; Inlet Fitting To Trans.  
 Chev; Blazer Full Size; 1987; V-8 5.0 Eng.; Outlet Fitting To Trans.  
 Chev; Blazer Full Size; 1994-1993; V-8 5.7 Eng.; Inlet Fitting To Trans. (Upper)  
 Chev; Blazer Full Size; 1994-1993; V-8 5.7 Eng.; Outlet Fitting To Trans. (Lower)  
 Chev; Blazer Full Size; 1992-1987; V-8 5.7 Eng.; Inlet Fitting To Trans.  
 Chev; Blazer Full Size; 1992-1987; V-8 5.7 Eng.; Outlet Fitting To Trans.

## Numerical Listing - Oil Cooler Assemblies & End Fittings

### A63006 - Continued

Chev; Blazer Full Size; 1991-1987; V-8 6.2 Diesel Eng.; Inlet Fitting To Trans. (Upper)

Chev; Blazer Full Size; 1991-1987; V-8 6.2 Diesel Eng.; Outlet Fitting To Trans. (Lower)

Chev; Blazer Full Size; 1994; V-8 6.5 Diesel Eng.; Inlet Fitting To Trans. (Upper)

Chev; Blazer Full Size; 1994; V-8 6.5 Diesel Eng.; Outlet Fitting To Trans. (Lower)

Chev; C&K Pickup; 1986-1985; 6-Cyl. 4.8 Eng.; Inlet Fitting To Trans. (Upper)

Chev; C&K Pickup; 1986-1985; 6-Cyl. 4.8 Eng.; Outlet Fitting To Trans. (Lower)

Chev; C&K Pickup; 1995-1994; V-6 4.3 Eng.; Inlet Fitting To Trans. (Upper)

Chev; C&K Pickup; 1995-1994; V-6 4.3 Eng.; Outlet Fitting To Trans. (Lower)

Chev; C&K Pickup; 1993; V-6 4.3 Eng.; Inlet Fitting To Trans. (Lower)

Chev; C&K Pickup; 1993; V-6 4.3 Eng.; Outlet Fitting To Trans. (Upper)

Chev; C&K Pickup; 1992-1988; V-6 4.3 Eng.; Inlet Fitting To Trans. (Upper)

Chev; C&K Pickup; 1992-1988; V-6 4.3 Eng.; Outlet Fitting To Trans. (Lower)

Chev; C&K Pickup; 1986-1985; V-6 4.3 Eng.; Inlet Fitting To Trans. (Upper)

Chev; C&K Pickup; 1986-1985; V-6 4.3 Eng.; Outlet Fitting To Trans. (Lower)

Chev; C&K Pickup; 1997; V-8 5.0 Eng.; Inlet Fitting To Trans. (Upper); W/Fact Fitting

Chev; C&K Pickup; 1997; V-8 5.0 Eng.; Outlet Fitting To Trans. (Lower); W/Fact Fitting

Chev; C&K Pickup; 1995-1994; V-8 5.0 Eng.; Inlet Fitting To Trans. (Upper)

Chev; C&K Pickup; 1995-1994; V-8 5.0 Eng.; Outlet Fitting To Trans. (Lower)

Chev; C&K Pickup; 1993; V-8 5.0 Eng.; Inlet Fitting To Trans. (Lower)

Chev; C&K Pickup; 1993; V-8 5.0 Eng.; Outlet Fitting To Trans. (Upper)

Chev; C&K Pickup; 1992-1988; V-8 5.0 Eng.; Inlet Fitting To Trans. (Upper)

Chev; C&K Pickup; 1992-1988; V-8 5.0 Eng.; Outlet Fitting To Trans. (Lower)

Chev; C&K Pickup; 1986-1985; V-8 5.0 Eng.; Inlet Fitting To Trans. (Upper)

Chev; C&K Pickup; 1986-1985; V-8 5.0 Eng.; Outlet Fitting To Trans. (Lower)

Chev; C&K Pickup; 2000-1996; V-8 5.7 Eng.; Inlet Fitting To Trans. (Upper); W/Fact Fitting; W/17-Bolt Trans. Pan (MT1)

Chev; C&K Pickup; 2000-1996; V-8 5.7 Eng.; Outlet Fitting To Trans. (Lower); W/17-Bolt Trans. Pan (MT1)

Chev; C&K Pickup; 1995-1988; V-8 5.7 Eng.; Inlet Fitting To Trans. (Upper)

Chev; C&K Pickup; 1995-1988; V-8 5.7 Eng.; Outlet Fitting To Trans. (Lower)

Chev; C&K Pickup; 1986-1985; V-8 5.7 Eng.; Inlet Fitting To Trans. (Upper)

Chev; C&K Pickup; 1986-1985; V-8 5.7 Eng.; Outlet Fitting To Trans. (Lower)

Chev; C&K Pickup; 1993-1988; V-8 6.2 Diesel Eng.; Inlet Fitting To Trans. (Upper)

Chev; C&K Pickup; 1993-1988; V-8 6.2 Diesel Eng.; Outlet Fitting To Trans. (Lower)

Chev; C&K Pickup; 1986-1985; V-8 6.2 Diesel Eng.; Inlet Fitting To Trans. (Upper)

Chev; C&K Pickup; 1986-1985; V-8 6.2 Diesel Eng.; Outlet Fitting To Trans. (Lower)

Chev; C&K Pickup; 2002-1996; V-8 6.5 Diesel Eng.; Inlet Fitting To Trans. (Upper); W/Fact Fitting

Chev; C&K Pickup; 2002-1997; V-8 6.5 Diesel Eng.; Outlet Fitting To Trans. (Lower)

Chev; C&K Pickup; 1996; V-8 6.5 Diesel Eng.; Outlet Fitting To Trans. (Lower); W/Fact Fitting

Chev; C&K Pickup; 1995-1992; V-8 6.5 Diesel Eng.; Inlet Fitting To Trans. (Upper)

Chev; C&K Pickup; 1995-1992; V-8 6.5 Diesel Eng.; Outlet Fitting To Trans. (Lower)

Chev; C&K Pickup; 2000-1997; V-8 7.4 Eng.; Inlet Fitting To Trans. (Upper); W/Fact Fitting

Chev; C&K Pickup; 2000-1997; V-8 7.4 Eng.; Outlet Fitting To Trans. (Lower)

Chev; C&K Pickup; 1995-1988; V-8 7.4 Eng.; Inlet Fitting To Trans. (Upper)

Chev; C&K Pickup; 1995-1988; V-8 7.4 Eng.; Outlet Fitting To Trans. (Lower)

Chev; C&K Pickup; 1986-1985; V-8 7.4 Eng.; Inlet Fitting To Trans. (Upper)

### A63006 - Continued

Chev; C&K Pickup; 1986-1985; V-8 7.4 Eng.; Outlet Fitting To Trans. (Lower)

Chev; C&K Pickup; 2002-2001; V-8 8.1 Eng.; Inlet Fitting To Trans. (Upper); W/Fact Fitting

Chev; C&K Pickup; 2002-2001; V-8 8.1 Eng.; Outlet Fitting To Trans. (Lower)

Chev; Camaro; 1986-1983; 4-Cyl. 2.5 Eng.; Inlet Fitting To Trans. (Upper)

Chev; Camaro; 1986-1983; 4-Cyl. 2.5 Eng.; Outlet Fitting To Trans. (Lower)

Chev; Camaro; 1989-1983; V-6 2.8 Eng.; Inlet Fitting To Trans. (Upper)

Chev; Camaro; 1989-1983; V-6 2.8 Eng.; Outlet Fitting To Trans. (Lower)

Chev; Camaro; 1992-1990; V-6 3.1 Eng.; Inlet Fitting To Trans. (Upper)

Chev; Camaro; 1992-1990; V-6 3.1 Eng.; Outlet Fitting To Trans. (Lower)

Chev; Camaro; 1995-1993; V-6 3.4 Eng.; Inlet Fitting To Trans. (Upper)

Chev; Camaro; 1995-1993; V-6 3.4 Eng.; Outlet Fitting To Trans. (Lower)

Chev; Camaro; 1997-1995; V-6 3.8 Eng.; Inlet Fitting To Trans. (Upper)

Chev; Camaro; 1997-1995; V-6 3.8 Eng.; Outlet Fitting To Trans. (Lower)

Chev; Camaro; 1992-1983; V-8 5.0 Eng.; Inlet Fitting To Trans. (Upper)

Chev; Camaro; 1992-1983; V-8 5.0 Eng.; Outlet Fitting To Trans. (Lower)

Chev; Camaro; 1997-1987; V-8 5.7 Eng.; Inlet Fitting To Trans. (Upper)

Chev; Camaro; 1997-1987; V-8 5.7 Eng.; Outlet Fitting To Trans. (Lower)

Chev; Caprice; 1993-1992; V-6 4.3 Eng.; Inlet Fitting To Trans. (Upper)

Chev; Caprice; 1993-1992; V-6 4.3 Eng.; Outlet Fitting To Trans. (Lower)

Chev; Caprice; 1990-1985; V-6 4.3 Eng.; Inlet Fitting To Trans. (Upper)

Chev; Caprice; 1990-1985; V-6 4.3 Eng.; Outlet Fitting To Trans. (Lower)

Chev; Caprice; 1993-1985; V-8 5.0 Eng.; Inlet Fitting To Trans. (Upper)

Chev; Caprice; 1993-1985; V-8 5.0 Eng.; Outlet Fitting To Trans. (Lower)

Chev; Caprice; 1993-1986; V-8 5.7 Eng.; Inlet Fitting To Trans. (Upper)

Chev; Caprice; 1993-1986; V-8 5.7 Eng.; Outlet Fitting To Trans. (Lower)

Chev; Caprice; 1985; V-8 5.7 Diesel Eng.; Inlet Fitting To Trans. (Upper)

Chev; Caprice; 1985; V-8 5.7 Diesel Eng.; Outlet Fitting To Trans. (Lower)

Chev; Cavalier; 1989-1986; 4-Cyl. 2.0 Eng.; Inlet Fitting To Trans. (Upper); W/3-Spd Trans.

Chev; Cavalier; 1989-1986; 4-Cyl. 2.0 Eng.; Outlet Fitting To Trans. (Lower); W/3-Spd Trans.

Chev; Cavalier; 2001-1990; 4-Cyl. 2.2 Eng.; Inlet Fitting To Trans. (Upper); W/3-Spd Trans.

Chev; Cavalier; 2001-1990; 4-Cyl. 2.2 Eng.; Outlet Fitting To Trans. (Lower); W/3-Spd Trans.

Chev; Cavalier; 1989-1985; V-6 2.8 Eng.; Inlet Fitting To Trans. (Upper); W/3-Spd Trans.

Chev; Cavalier; 1989-1985; V-6 2.8 Eng.; Outlet Fitting To Trans. (Lower); W/3-Spd Trans.

Chev; Cavalier; 1994-1990; V-6 3.1 Eng.; Inlet Fitting To Trans. (Upper); W/3-Spd Trans.

Chev; Cavalier; 1994-1990; V-6 3.1 Eng.; Outlet Fitting To Trans. (Lower); W/3-Spd Trans.

Chev; Celebrity; 1990-1985; 4-Cyl. 2.5 Eng.; Inlet Fitting To Trans. (Upper)

Chev; Celebrity; 1990-1985; 4-Cyl. 2.5 Eng.; Outlet Fitting To Trans. (Lower)

Chev; Celebrity; 1989-1985; V-6 2.8 Eng.; Inlet Fitting To Trans. (Upper)

Chev; Celebrity; 1989-1985; V-6 2.8 Eng.; Outlet Fitting To Trans. (Lower)

Chev; Celebrity; 1990; V-6 3.1 Eng.; Inlet Fitting To Trans. (Upper)

Chev; Celebrity; 1990; V-6 3.1 Eng.; Outlet Fitting To Trans. (Lower)

Chev; Corsica; 1989-1987; 4-Cyl. 2.0 Eng.; Inlet Fitting To Trans. (Upper)

Chev; Corsica; 1989-1987; 4-Cyl. 2.0 Eng.; Outlet Fitting To Trans. (Lower)

Chev; Corsica; 1996-1990; 4-Cyl. 2.2 Eng.; Inlet Fitting To Trans. (Upper)

Chev; Corsica; 1996-1990; 4-Cyl. 2.2 Eng.; Outlet Fitting To Trans. (Lower)

Chev; Corsica; 1989-1987; V-6 2.8 Eng.; Inlet Fitting To Trans. (Upper)

Chev; Corsica; 1989-1987; V-6 2.8 Eng.; Outlet Fitting To Trans. (Lower)

Chev; Corsica; 1993-1990; V-6 3.1 Eng.; Inlet Fitting To Trans. (Upper)

Chev; Corsica; 1993-1990; V-6 3.1 Eng.; Outlet Fitting To Trans. (Lower)

Chev; Corvette; 1996-1984; V-8 5.7 Eng.; Inlet Fitting To Trans. (Upper)

Chev; Corvette; 1996-1984; V-8 5.7 Eng.; Outlet Fitting To Trans. (Lower)

Chev; El Camino; 1987-1986; V-6 4.3 Eng.; Inlet Fitting To Trans. (Upper)

Chev; El Camino; 1987-1986; V-6 4.3 Eng.; Outlet Fitting To Trans. (Lower)

Chev; El Camino; 1987-1986; V-8 5.0 Eng.; Inlet Fitting To Trans. (Upper)

Chev; El Camino; 1987-1986; V-8 5.0 Eng.; Outlet Fitting To Trans. (Lower)

Chev; Express; 2003-1996; V-6 4.3 Eng.; Inlet Fitting To Trans. (Upper); W/17-Bolt Trans. Pan (MT1)

Chev; Express; 2003-1996; V-6 4.3 Eng.; Outlet Fitting To Trans. (Lower); W/17-Bolt Trans. Pan (MT1)

Chev; Express; 2002-1996; V-6 4.3 Eng.; Connector From Rad; W/17-Bolt Trans. Pan (MT1); 2 Req'd

Chev; Express; 2003; V-8 4.8 Eng.; Connector From Aux. Cooler; W/17-Bolt Trans. Pan (MT1); 2 Req'd

Chev; Express; 2002-1996; V-8 5.7 Eng.; Connector From Rad; W/17-Bolt Trans. Pan (MT1); 2 Req'd

# Numerical Listing - Oil Cooler Assemblies & End Fittings

## A63006 - Continued

Chev; Express; 2000-1998; V-8 5.7 Eng.; Inlet Fitting To Trans. (Upper); W/17-Bolt Trans. Pan (MT1)

Chev; Express; 2000-1996; V-8 5.7 Eng.; Outlet Fitting To Trans. (Lower); W/17-Bolt Trans. Pan (MT1)

Chev; Express; 1996; V-8 5.7 Eng.; Inlet Fitting To Trans. (Upper); W/17-Bolt Trans. Pan (MT1)

Chev; Express; 2003; V-8 6.0 Eng.; Connector From Aux. Cooler; 2 Reqd

Chev; Express; 2002-1997; V-8 6.5 Diesel Eng.; Connector From Rad; 2 Reqd

Chev; Express; 1996; V-8 6.5 Diesel Eng.; Connector From Rad; W/O Quick Connect Fitting; 2 Reqd

Chev; Express; 1996; V-8 6.5 Diesel Eng.; Inlet Fitting To Trans. (Upper)

Chev; Express; 1996; V-8 6.5 Diesel Eng.; Outlet Fitting To Trans. (Lower)

Chev; Express; 2000-1997; V-8 7.4 Eng.; Connector From Rad; 2 Reqd

Chev; Express; 1996; V-8 7.4 Eng.; Connector From Rad; W/O Aux. Cooler; 2 Reqd

Chev; Express; 1996; V-8 7.4 Eng.; Inlet Fitting To Trans. (Upper); W/O Aux. Cooler

Chev; Express; 1996; V-8 7.4 Eng.; Outlet Fitting To Trans. (Lower); W/O Aux. Cooler

Chev; Express; 2002-2001; V-8 8.1 Eng.; Connector From Rad; 2 Reqd

Chev; G Van; 1998-1997; V-6 4.3 Eng.; Connector From Rad; W/17-Bolt Trans. Pan (MT1); 2 Reqd

Chev; G Van; 1998-1997; V-6 4.3 Eng.; Inlet Fitting To Trans. (Upper); W/17-Bolt Trans. Pan (MT1)

Chev; G Van; 1998-1997; V-6 4.3 Eng.; Outlet Fitting To Trans. (Lower); W/17-Bolt Trans. Pan (MT1)

Chev; G Van; 1996-1986; V-6 4.3 Eng.; Inlet Fitting To Trans. (Upper)

Chev; G Van; 1996-1986; V-6 4.3 Eng.; Outlet Fitting To Trans. (Lower)

Chev; G Van; 1995-1986; V-8 5.0 Eng.; Inlet Fitting To Trans. (Upper)

Chev; G Van; 1995-1986; V-8 5.0 Eng.; Outlet Fitting To Trans. (Lower)

Chev; G Van; 1998-1997; V-8 5.7 Eng.; Connector From Rad; W/17-Bolt Trans. Pan (MT1); 2 Reqd

Chev; G Van; 1998-1997; V-8 5.7 Eng.; Inlet Fitting To Trans. (Upper); W/17-Bolt Trans. Pan (MT1)

Chev; G Van; 1998-1997; V-8 5.7 Eng.; Outlet Fitting To Trans. (Lower); W/17-Bolt Trans. Pan (MT1)

Chev; G Van; 1996-1986; V-8 5.7 Eng.; Inlet Fitting To Trans. (Upper)

Chev; G Van; 1996-1986; V-8 5.7 Eng.; Outlet Fitting To Trans. (Lower)

Chev; G Van; 1993-1986; V-8 6.2 Diesel Eng.; Inlet Fitting To Trans. (Upper)

Chev; G Van; 1993-1986; V-8 6.2 Diesel Eng.; Outlet Fitting To Trans. (Lower)

Chev; G Van; 1998-1997; V-8 6.5 Diesel Eng.; Connector From Rad; 2 Reqd

Chev; G Van; 1996-1994; V-8 6.5 Diesel Eng.; Inlet Fitting To Trans. (Upper)

Chev; G Van; 1996-1994; V-8 6.5 Diesel Eng.; Outlet Fitting To Trans. (Lower)

Chev; G Van; 1998-1997; V-8 7.4 Eng.; Connector From Rad; 2 Reqd

Chev; G Van; 1996-1988; V-8 7.4 Eng.; Inlet Fitting To Trans. (Upper)

Chev; G Van; 1996-1988; V-8 7.4 Eng.; Outlet Fitting To Trans. (Lower)

Chev; Impala; 1985; V-6 4.3 Eng.; Inlet Fitting To Trans. (Upper)

Chev; Impala; 1985; V-6 4.3 Eng.; Outlet Fitting To Trans. (Lower)

Chev; Impala; 1985; V-8 5.0 Eng.; Inlet Fitting To Trans. (Upper)

Chev; Impala; 1985; V-8 5.0 Eng.; Outlet Fitting To Trans. (Lower)

Chev; Impala; 1985; V-8 5.7 Eng.; Inlet Fitting To Trans. (Upper)

Chev; Impala; 1985; V-8 5.7 Eng.; Outlet Fitting To Trans. (Lower)

Chev; LLV (Postal Vehicle); 1995-1994; 4-Cyl. 2.2 Eng.; Tube Nut; As Reqd

Chev; LLV (Postal Vehicle); 1993-1987; 4-Cyl. 2.5 Eng.; Tube Nut; As Reqd

Chev; Lumina; 1992-1990; 4-Cyl. 2.5 Eng.; Inlet Fitting To Trans. (Upper)

Chev; Lumina; 1992-1990; 4-Cyl. 2.5 Eng.; Outlet Fitting To Trans. (Lower)

Chev; Lumina; 1993-1991; V-6 3.1 Eng.; Inlet Fitting To Trans. (Upper); W/3-Spd Trans.

Chev; Lumina; 1993-1990; V-6 3.1 Eng.; Outlet Fitting To Trans. (Lower); W/3-Spd Trans.

Chev; Lumina; 1990; V-6 3.1 Eng.; Inlet Fitting To Trans. (Upper)

Chev; Lumina APV; 1995-1990; V-6 3.1 Eng.; Inlet Fitting To Trans. (Upper)

Chev; Lumina APV; 1995-1990; V-6 3.1 Eng.; Outlet Fitting To Trans. (Lower)

Chev; Monte Carlo; 1984-1982; V-6 3.8 Eng.; Inlet Fitting To Trans. (Upper)

Chev; Monte Carlo; 1984-1982; V-6 3.8 Eng.; Outlet Fitting To Trans. (Lower)

Chev; Monte Carlo; 1988-1985; V-6 4.3 Eng.; Inlet Fitting To Trans. (Upper)

Chev; Monte Carlo; 1988-1985; V-6 4.3 Eng.; Outlet Fitting To Trans. (Lower)

## A63006 - Continued

Chev; Monte Carlo; 1988-1982; V-8 5.0 Eng.; Inlet Fitting To Trans. (Upper)

Chev; Monte Carlo; 1988-1982; V-8 5.0 Eng.; Outlet Fitting To Trans. (Lower)

Chev; R&V Pickup; 1988-1987; 6-Cyl. 4.8 Eng.; Inlet Fitting To Trans. (Upper)

Chev; R&V Pickup; 1988-1987; 6-Cyl. 4.8 Eng.; Outlet Fitting To Trans. (Lower)

Chev; R&V Pickup; 1987; V-6 4.3 Eng.; Inlet Fitting To Trans. (Upper)

Chev; R&V Pickup; 1987; V-6 4.3 Eng.; Outlet Fitting To Trans. (Lower)

Chev; R&V Pickup; 1991-1987; V-8 5.7 Eng.; Inlet Fitting To Trans. (Upper)

Chev; R&V Pickup; 1991-1987; V-8 5.7 Eng.; Outlet Fitting To Trans. (Lower)

Chev; R&V Pickup; 1991-1987; V-8 6.2 Diesel Eng.; Inlet Fitting To Trans. (Upper)

Chev; R&V Pickup; 1991-1987; V-8 6.2 Diesel Eng.; Outlet Fitting To Trans. (Lower)

Chev; R&V Pickup; 1991-1987; V-8 7.4 Eng.; Inlet Fitting To Trans. (Upper)

Chev; R&V Pickup; 1991-1987; V-8 7.4 Eng.; Outlet Fitting To Trans. (Lower)

Chev; S Pickup; 1997-1994; 4-Cyl. 2.2 Eng.; Inlet Fitting To Trans. (Lower)

Chev; S Pickup; 1997-1994; 4-Cyl. 2.2 Eng.; Outlet Fitting To Trans. (Upper)

Chev; S Pickup; 1993-1986; 4-Cyl. 2.5 Eng.; Inlet Fitting To Trans. (Lower)

Chev; S Pickup; 1993-1986; 4-Cyl. 2.5 Eng.; Outlet Fitting To Trans. (Upper)

Chev; S Pickup; 1993-1986; V-6 2.8 Eng.; Inlet Fitting To Trans. (Lower)

Chev; S Pickup; 1993-1986; V-6 2.8 Eng.; Outlet Fitting To Trans. (Upper)

Chev; S Pickup; 1995-1994; V-6 4.3 Eng.; Connector From Rad; 2 Reqd

Chev; S Pickup; 1995-1988; V-6 4.3 Eng.; Inlet Fitting To Trans. (Lower)

Chev; S Pickup; 1995-1988; V-6 4.3 Eng.; Outlet Fitting To Trans. (Upper)

Chev; Silverado Pickup; 2003-1999; V-6 4.3 Eng.; Outlet Fitting To Trans. (Lower)

Chev; Silverado Pickup; 2003-1999; V-8 4.8 Eng.; Outlet Fitting To Trans. (Lower)

Chev; Silverado Pickup; 2003-1999; V-8 5.3 Eng.; Outlet Fitting To Trans. (Lower)

Chev; Silverado Pickup; 2002-2001; V-8 6.0 Eng.; Outlet Fitting To Trans. (Lower); W/16-Bolt Trans. Pan (M30)

Chev; Silverado Pickup; 1999; V-8 6.5 Diesel Eng.; Inlet Fitting To Trans. (Upper); W/Fact Fitting

Chev; Silverado Pickup; 1999; V-8 6.5 Diesel Eng.; Outlet Fitting To Trans. (Lower)

Chev; Suburban; 1987-1985; V-8 5.0 Eng.; Inlet Fitting To Trans. (Upper)

Chev; Suburban; 1987-1985; V-8 5.0 Eng.; Outlet Fitting To Trans. (Lower)

Chev; Suburban; 2003-2000; V-8 5.3 Eng.; Outlet Fitting To Trans. (Lower)

Chev; Suburban; 1999-1996; V-8 5.7 Eng.; Inlet Fitting To Trans. (Upper); W/Fact Fitting; W/17-Bolt Trans. Pan (MT1)

Chev; Suburban; 1999-1996; V-8 5.7 Eng.; Outlet Fitting To Trans. (Lower); W/17-Bolt Trans. Pan (MT1)

Chev; Suburban; 1995-1985; V-8 5.7 Eng.; Inlet Fitting To Trans. (Upper)

Chev; Suburban; 1995-1985; V-8 5.7 Eng.; Outlet Fitting To Trans. (Lower)

Chev; Suburban; 1991-1985; V-8 6.2 Diesel Eng.; Inlet Fitting To Trans. (Upper)

Chev; Suburban; 1991-1985; V-8 6.2 Diesel Eng.; Outlet Fitting To Trans. (Lower)

Chev; Suburban; 1999-1996; V-8 6.5 Diesel Eng.; Inlet Fitting To Trans. (Upper); W/Fact Fitting

Chev; Suburban; 1999-1994; V-8 6.5 Diesel Eng.; Outlet Fitting To Trans. (Lower)

Chev; Suburban; 1995-1994; V-8 6.5 Diesel Eng.; Inlet Fitting To Trans. (Upper)

Chev; Suburban; 1999-1996; V-8 7.4 Eng.; Inlet Fitting To Trans. (Upper); W/Fact Fitting

Chev; Suburban; 1999-1985; V-8 7.4 Eng.; Outlet Fitting To Trans. (Lower)

Chev; Suburban; 1995-1985; V-8 7.4 Eng.; Inlet Fitting To Trans. (Upper)

Chev; Suburban; 2002-2001; V-8 8.1 Eng.; Connector From Rad; 2 Reqd

Chev; Tahoe; 2003-2000; V-8 4.8 Eng.; Outlet Fitting To Trans. (Lower)

Chev; Tahoe; 2003-2000; V-8 5.3 Eng.; Outlet Fitting To Trans. (Lower)

Chev; Tahoe; 1995; V-8 5.7 Eng.; Inlet Fitting To Trans. (Upper)

Chev; Tahoe; 1995; V-8 5.7 Eng.; Outlet Fitting To Trans. (Lower)

Chev; Tahoe; 1999-1996; V-8 6.5 Diesel Eng.; Inlet Fitting To Trans. (Upper); W/Fact Fitting

Chev; Tahoe; 1999-1995; V-8 6.5 Diesel Eng.; Outlet Fitting To Trans. (Lower)

Chev; Tahoe; 1995; V-8 6.5 Diesel Eng.; Inlet Fitting To Trans. (Upper)



## Numerical Listing - Oil Cooler Assemblies & End Fittings

### A63006 - Continued

Chev; Trailblazer; 2004-2003; V-8 5.3 Eng.; Outlet Fitting To Trans. (Lower)

GMC; C&K Pickup; 1986-1985; 6-Cyl. 4.8 Eng.; Inlet Fitting To Trans. (Upper)

GMC; C&K Pickup; 1986-1985; 6-Cyl. 4.8 Eng.; Outlet Fitting To Trans. (Lower)

GMC; C&K Pickup; 1995-1994; V-6 4.3 Eng.; Inlet Fitting To Trans. (Upper)

GMC; C&K Pickup; 1995-1994; V-6 4.3 Eng.; Outlet Fitting To Trans. (Lower)

GMC; C&K Pickup; 1993; V-6 4.3 Eng.; Inlet Fitting To Trans. (Lower)

GMC; C&K Pickup; 1993; V-6 4.3 Eng.; Outlet Fitting To Trans. (Upper)

GMC; C&K Pickup; 1992-1988; V-6 4.3 Eng.; Inlet Fitting To Trans. (Upper)

GMC; C&K Pickup; 1992-1988; V-6 4.3 Eng.; Outlet Fitting To Trans. (Lower)

GMC; C&K Pickup; 1986-1985; V-6 4.3 Eng.; Inlet Fitting To Trans. (Upper)

GMC; C&K Pickup; 1986-1985; V-6 4.3 Eng.; Outlet Fitting To Trans. (Lower)

GMC; C&K Pickup; 1997; V-8 5.0 Eng.; Inlet Fitting To Trans. (Upper); W/Fact Fitting

GMC; C&K Pickup; 1997; V-8 5.0 Eng.; Outlet Fitting To Trans. (Lower); W/Fact Fitting

GMC; C&K Pickup; 1995-1994; V-8 5.0 Eng.; Inlet Fitting To Trans. (Upper)

GMC; C&K Pickup; 1995-1994; V-8 5.0 Eng.; Outlet Fitting To Trans. (Lower)

GMC; C&K Pickup; 1993; V-8 5.0 Eng.; Inlet Fitting To Trans. (Lower)

GMC; C&K Pickup; 1993; V-8 5.0 Eng.; Outlet Fitting To Trans. (Upper)

GMC; C&K Pickup; 1992-1988; V-8 5.0 Eng.; Inlet Fitting To Trans. (Upper)

GMC; C&K Pickup; 1992-1988; V-8 5.0 Eng.; Outlet Fitting To Trans. (Lower)

GMC; C&K Pickup; 1986-1985; V-8 5.0 Eng.; Inlet Fitting To Trans. (Upper)

GMC; C&K Pickup; 1986-1985; V-8 5.0 Eng.; Outlet Fitting To Trans. (Lower)

GMC; C&K Pickup; 2000-1996; V-8 5.7 Eng.; Inlet Fitting To Trans. (Upper); W/Fact Fitting; W/17-Bolt Trans. Pan (MT1)

GMC; C&K Pickup; 2000-1996; V-8 5.7 Eng.; Outlet Fitting To Trans. (Lower); W/17-Bolt Trans. Pan (MT1)

GMC; C&K Pickup; 1995-1988; V-8 5.7 Eng.; Inlet Fitting To Trans. (Upper)

GMC; C&K Pickup; 1995-1988; V-8 5.7 Eng.; Outlet Fitting To Trans. (Lower)

GMC; C&K Pickup; 1986-1985; V-8 5.7 Eng.; Inlet Fitting To Trans. (Upper)

GMC; C&K Pickup; 1986-1985; V-8 5.7 Eng.; Outlet Fitting To Trans. (Lower)

GMC; C&K Pickup; 1993-1988; V-8 6.2 Diesel Eng.; Inlet Fitting To Trans. (Upper)

GMC; C&K Pickup; 1993-1988; V-8 6.2 Diesel Eng.; Outlet Fitting To Trans. (Lower)

GMC; C&K Pickup; 1986-1985; V-8 6.2 Diesel Eng.; Inlet Fitting To Trans. (Upper)

GMC; C&K Pickup; 1986-1985; V-8 6.2 Diesel Eng.; Outlet Fitting To Trans. (Lower)

GMC; C&K Pickup; 2002-1996; V-8 6.5 Diesel Eng.; Inlet Fitting To Trans. (Upper); W/Fact Fitting

GMC; C&K Pickup; 2002-1997; V-8 6.5 Diesel Eng.; Outlet Fitting To Trans. (Lower)

GMC; C&K Pickup; 1996; V-8 6.5 Diesel Eng.; Outlet Fitting To Trans. (Lower); W/Fact Fitting

GMC; C&K Pickup; 1995-1992; V-8 6.5 Diesel Eng.; Inlet Fitting To Trans. (Upper)

GMC; C&K Pickup; 1995-1992; V-8 6.5 Diesel Eng.; Outlet Fitting To Trans. (Lower)

GMC; C&K Pickup; 2000-1996; V-8 7.4 Eng.; Inlet Fitting To Trans. (Upper); W/Fact Fitting

GMC; C&K Pickup; 2000-1988; V-8 7.4 Eng.; Outlet Fitting To Trans. (Lower)

GMC; C&K Pickup; 1995-1988; V-8 7.4 Eng.; Inlet Fitting To Trans. (Upper)

GMC; C&K Pickup; 1986-1985; V-8 7.4 Eng.; Inlet Fitting To Trans. (Upper)

GMC; C&K Pickup; 1986-1985; V-8 7.4 Eng.; Outlet Fitting To Trans. (Lower)

GMC; C&K Pickup; 2002-2001; V-8 8.1 Eng.; Inlet Fitting To Trans. (Upper); W/Fact Fitting

GMC; C&K Pickup; 2002-2001; V-8 8.1 Eng.; Outlet Fitting To Trans. (Lower)

GMC; Caballero; 1987-1986; V-6 4.3 Eng.; Inlet Fitting To Trans. (Lower)

### A63006 - Continued

GMC; Caballero; 1987-1986; V-6 4.3 Eng.; Outlet Fitting To Trans. (Upper)

GMC; Caballero; 1987-1986; V-8 5.0 Eng.; Inlet Fitting To Trans. (Lower)

GMC; Caballero; 1987-1986; V-8 5.0 Eng.; Outlet Fitting To Trans. (Upper)

GMC; Envoy; 2004-2003; V-8 5.3 Eng.; Outlet Fitting To Trans. (Lower)

GMC; G Van; 1996-1986; V-6 4.3 Eng.; Inlet Fitting To Trans. (Upper)

GMC; G Van; 1996-1986; V-6 4.3 Eng.; Outlet Fitting To Trans. (Lower)

GMC; G Van; 1995-1986; V-8 5.0 Eng.; Inlet Fitting To Trans. (Upper)

GMC; G Van; 1995-1986; V-8 5.0 Eng.; Outlet Fitting To Trans. (Lower)

GMC; G Van; 1996-1986; V-8 5.7 Eng.; Inlet Fitting To Trans. (Upper)

GMC; G Van; 1996-1986; V-8 5.7 Eng.; Outlet Fitting To Trans. (Lower)

GMC; G Van; 1993-1986; V-8 6.2 Diesel Eng.; Inlet Fitting To Trans. (Upper)

GMC; G Van; 1993-1986; V-8 6.2 Diesel Eng.; Outlet Fitting To Trans. (Lower)

GMC; G Van; 1996-1994; V-8 6.5 Diesel Eng.; Inlet Fitting To Trans. (Upper)

GMC; G Van; 1996-1994; V-8 6.5 Diesel Eng.; Outlet Fitting To Trans. (Lower)

GMC; G Van; 1996-1988; V-8 7.4 Eng.; Inlet Fitting To Trans. (Upper)

GMC; G Van; 1996-1988; V-8 7.4 Eng.; Outlet Fitting To Trans. (Lower)

GMC; Jimmy; 1995-1992; V-6 4.3 Eng.; Connector From Rad; 2 Reqd

GMC; Jimmy; 1995-1992; V-6 4.3 Eng.; Inlet Fitting To Trans. (Lower)

GMC; Jimmy; 1995-1992; V-6 4.3 Eng.; Outlet Fitting To Trans. (Upper)

GMC; Jimmy Compact; 1988-1987; 4-Cyl. 2.5 Eng.; Inlet Fitting To Trans.

GMC; Jimmy Compact; 1988-1987; 4-Cyl. 2.5 Eng.; Outlet Fitting To Trans.

GMC; Jimmy Compact; 1989-1987; V-6 2.8 Eng.; Inlet Fitting To Trans.

GMC; Jimmy Compact; 1989-1987; V-6 2.8 Eng.; Outlet Fitting To Trans.

GMC; Jimmy Compact; 1991-1988; V-6 4.3 Eng.; Inlet Fitting To Trans.

GMC; Jimmy Compact; 1991-1988; V-6 4.3 Eng.; Outlet Fitting To Trans.

GMC; Jimmy Full Size; 1987; V-8 5.0 Eng.; Inlet Fitting To Trans.

GMC; Jimmy Full Size; 1987; V-8 5.0 Eng.; Outlet Fitting To Trans.

GMC; Jimmy Full Size; 1991-1987; V-8 5.7 Eng.; Inlet Fitting To Trans.

GMC; Jimmy Full Size; 1991-1987; V-8 5.7 Eng.; Outlet Fitting To Trans.

GMC; Jimmy Full Size; 1991-1987; V-8 6.2 Diesel Eng.; Inlet Fitting To Trans. (Upper)

GMC; Jimmy Full Size; 1991-1987; V-8 6.2 Diesel Eng.; Outlet Fitting To Trans. (Lower)

GMC; R&V Pickup; 1988-1987; 6-Cyl. 4.8 Eng.; Inlet Fitting To Trans. (Upper)

GMC; R&V Pickup; 1988-1987; 6-Cyl. 4.8 Eng.; Outlet Fitting To Trans. (Lower)

GMC; R&V Pickup; 1987; V-6 4.3 Eng.; Inlet Fitting To Trans. (Upper)

GMC; R&V Pickup; 1987; V-6 4.3 Eng.; Outlet Fitting To Trans. (Lower)

GMC; R&V Pickup; 1987; V-8 5.0 Eng.; Inlet Fitting To Trans. (Upper)

GMC; R&V Pickup; 1987; V-8 5.0 Eng.; Outlet Fitting To Trans. (Lower)

GMC; R&V Pickup; 1991-1987; V-8 5.7 Eng.; Inlet Fitting To Trans. (Upper)

GMC; R&V Pickup; 1991-1987; V-8 5.7 Eng.; Outlet Fitting To Trans. (Lower)

GMC; R&V Pickup; 1991-1987; V-8 6.2 Diesel Eng.; Inlet Fitting To Trans. (Upper)

GMC; R&V Pickup; 1991-1987; V-8 6.2 Diesel Eng.; Outlet Fitting To Trans. (Lower)

GMC; R&V Pickup; 1991-1987; V-8 7.4 Eng.; Inlet Fitting To Trans. (Upper)

GMC; R&V Pickup; 1991-1987; V-8 7.4 Eng.; Outlet Fitting To Trans. (Lower)

GMC; S Pickup; 1990-1986; 4-Cyl. 2.5 Eng.; Inlet Fitting To Trans. (Lower)

GMC; S Pickup; 1990-1986; 4-Cyl. 2.5 Eng.; Outlet Fitting To Trans. (Upper)

GMC; S Pickup; 1990-1986; V-6 2.8 Eng.; Inlet Fitting To Trans. (Lower)

GMC; S Pickup; 1990-1986; V-6 2.8 Eng.; Outlet Fitting To Trans. (Upper)

GMC; S Pickup; 1990-1988; V-6 4.3 Eng.; Inlet Fitting To Trans. (Lower)

GMC; S Pickup; 1990-1988; V-6 4.3 Eng.; Outlet Fitting To Trans. (Upper)

GMC; Safari; 1990-1985; 4-Cyl. 2.5 Eng.; Inlet Fitting To Trans. (Upper)

GMC; Safari; 1990-1985; 4-Cyl. 2.5 Eng.; Outlet Fitting To Trans. (Lower)

GMC; Safari; 1989-1985; 4-Cyl. 2.5 Eng.; Connector From Rad; 2 Reqd

GMC; Safari; 1995-1985; V-6 4.3 Eng.; Inlet Fitting To Trans. (Upper)

GMC; Safari; 1995-1985; V-6 4.3 Eng.; Outlet Fitting To Trans. (Lower)

GMC; Safari; 1990; V-6 4.3 Eng.; Connector From Rad; W/RWD; 2 Reqd

GMC; Safari; 1989-1985; V-6 4.3 Eng.; Connector From Rad; 2 Reqd

GMC; Savana; 2003-1996; V-6 4.3 Eng.; Inlet Fitting To Trans. (Upper); W/17-Bolt Trans. Pan (MT1)

GMC; Savana; 2003-1996; V-6 4.3 Eng.; Outlet Fitting To Trans. (Lower); W/17-Bolt Trans. Pan (MT1)

GMC; Savana; 2002-1996; V-6 4.3 Eng.; Connector From Rad; W/17-Bolt Trans. Pan (MT1); 2 Reqd

GMC; Savana; 2003; V-8 4.8 Eng.; Connector From Aux. Cooler; W/17-Bolt Trans. Pan (MT1); 2 Reqd

# Numerical Listing - Oil Cooler Assemblies & End Fittings

## A63006 - Continued

GMC; Savana; 2002-1996; V-8 5.7 Eng.; Connector From Rad; W/17-Bolt Trans. Pan (MT1); 2 Req'd  
 GMC; Savana; 2000-1998; V-8 5.7 Eng.; Inlet Fitting To Trans. (Upper); W/17-Bolt Trans. Pan (MT1)  
 GMC; Savana; 2000-1996; V-8 5.7 Eng.; Outlet Fitting To Trans. (Lower); W/17-Bolt Trans. Pan (MT1)  
 GMC; Savana; 1996; V-8 5.7 Eng.; Inlet Fitting To Trans. (Upper); W/17-Bolt Trans. Pan (MT1)  
 GMC; Savana; 2003; V-8 6.0 Eng.; Connector From Aux. Cooler; 2 Req'd  
 GMC; Savana; 2002-1997; V-8 6.5 Diesel Eng.; Connector From Rad; 2 Req'd  
 GMC; Savana; 1996; V-8 6.5 Diesel Eng.; Connector From Rad; W/O Quick Connect Fitting; 2 Req'd  
 GMC; Savana; 1996; V-8 6.5 Diesel Eng.; Inlet Fitting To Trans. (Upper)  
 GMC; Savana; 1996; V-8 6.5 Diesel Eng.; Outlet Fitting To Trans. (Lower)  
 GMC; Savana; 2000-1997; V-8 7.4 Eng.; Connector From Rad; 2 Req'd  
 GMC; Savana; 1996; V-8 7.4 Eng.; Connector From Rad; W/O Aux. Cooler; 2 Req'd  
 GMC; Savana; 1996; V-8 7.4 Eng.; Inlet Fitting To Trans. (Upper); W/O Aux. Cooler  
 GMC; Savana; 1996; V-8 7.4 Eng.; Outlet Fitting To Trans. (Lower); W/O Aux. Cooler  
 GMC; Savana; 2002-2001; V-8 8.1 Eng.; Connector From Rad; 2 Req'd  
 GMC; Sierra Pickup; 2003-1999; V-6 4.3 Eng.; Outlet Fitting To Trans. (Lower)  
 GMC; Sierra Pickup; 2003-1999; V-8 4.8 Eng.; Outlet Fitting To Trans. (Lower)  
 GMC; Sierra Pickup; 2003-1999; V-8 5.3 Eng.; Outlet Fitting To Trans. (Lower)  
 GMC; Sierra Pickup; 2002-2001; V-8 6.0 Eng.; Outlet Fitting To Trans. (Lower); W/16-Bolt Trans. Pan (M30)  
 GMC; Sierra Pickup; 1999; V-8 6.5 Diesel Eng.; Inlet Fitting To Trans. (Upper); W/Fact Fitting  
 GMC; Sierra Pickup; 1999; V-8 6.5 Diesel Eng.; Outlet Fitting To Trans. (Lower)  
 GMC; Sonoma; 1997-1994; 4-Cyl. 2.2 Eng.; Inlet Fitting To Trans. (Lower)  
 GMC; Sonoma; 1997-1994; 4-Cyl. 2.2 Eng.; Outlet Fitting To Trans. (Upper)  
 GMC; Sonoma; 1993-1991; 4-Cyl. 2.5 Eng.; Inlet Fitting To Trans. (Lower)  
 GMC; Sonoma; 1993-1991; 4-Cyl. 2.5 Eng.; Outlet Fitting To Trans. (Upper)  
 GMC; Sonoma; 1993-1991; V-6 2.8 Eng.; Inlet Fitting To Trans. (Lower)  
 GMC; Sonoma; 1993-1991; V-6 2.8 Eng.; Outlet Fitting To Trans. (Upper)  
 GMC; Sonoma; 1995-1994; V-6 4.3 Eng.; Connector From Rad; 2 Req'd  
 GMC; Sonoma; 1995-1991; V-6 4.3 Eng.; Inlet Fitting To Trans. (Lower)  
 GMC; Sonoma; 1995-1991; V-6 4.3 Eng.; Outlet Fitting To Trans. (Upper)  
 GMC; Suburban; 1987-1985; V-8 5.0 Eng.; Inlet Fitting To Trans. (Upper)  
 GMC; Suburban; 1987-1985; V-8 5.0 Eng.; Outlet Fitting To Trans. (Lower)  
 GMC; Suburban; 1999-1996; V-8 5.7 Eng.; Inlet Fitting To Trans. (Upper); W/Fact Fitting; W/17-Bolt Trans. Pan (MT1)  
 GMC; Suburban; 1999-1996; V-8 5.7 Eng.; Outlet Fitting To Trans. (Lower); W/17-Bolt Trans. Pan (MT1)  
 GMC; Suburban; 1995-1985; V-8 5.7 Eng.; Inlet Fitting To Trans. (Upper)  
 GMC; Suburban; 1995-1985; V-8 5.7 Eng.; Outlet Fitting To Trans. (Lower)  
 GMC; Suburban; 1991-1985; V-8 6.2 Diesel Eng.; Inlet Fitting To Trans. (Upper)  
 GMC; Suburban; 1991-1985; V-8 6.2 Diesel Eng.; Outlet Fitting To Trans. (Lower)  
 GMC; Suburban; 1999-1996; V-8 6.5 Diesel Eng.; Inlet Fitting To Trans. (Upper); W/Fact Fitting  
 GMC; Suburban; 1999-1994; V-8 6.5 Diesel Eng.; Outlet Fitting To Trans. (Lower)  
 GMC; Suburban; 1995-1994; V-8 6.5 Diesel Eng.; Inlet Fitting To Trans. (Upper)  
 GMC; Suburban; 1999-1996; V-8 7.4 Eng.; Inlet Fitting To Trans. (Upper); W/Fact Fitting  
 GMC; Suburban; 1999-1985; V-8 7.4 Eng.; Outlet Fitting To Trans. (Lower)  
 GMC; Suburban; 1995-1985; V-8 7.4 Eng.; Inlet Fitting To Trans. (Upper)  
 GMC; Syclone; 1992-1991; V-6 4.3 Eng.; Inlet Fitting To Trans. (Lower)  
 GMC; Syclone; 1992-1991; V-6 4.3 Eng.; Outlet Fitting To Trans. (Upper)  
 GMC; Typhoon; 1993-1992; V-6 4.3 Eng.; Inlet Fitting To Trans. (Lower)  
 GMC; Typhoon; 1993-1992; V-6 4.3 Eng.; Outlet Fitting To Trans. (Upper)  
 GMC; Yukon; 2003-2000; V-8 4.8 Eng.; Outlet Fitting To Trans. (Lower)  
 GMC; Yukon; 2003-2000; V-8 5.3 Eng.; Outlet Fitting To Trans. (Lower)  
 GMC; Yukon; 1999-1996; V-8 5.7 Eng.; Inlet Fitting To Trans. (Upper); W/Fact Fitting; W/17-Bolt Trans. Pan (MT1)  
 GMC; Yukon; 1999-1996; V-8 5.7 Eng.; Outlet Fitting To Trans. (Lower); W/17-Bolt Trans. Pan (MT1)  
 GMC; Yukon; 1995-1992; V-8 5.7 Eng.; Inlet Fitting To Trans. (Upper)  
 GMC; Yukon; 1995-1992; V-8 5.7 Eng.; Outlet Fitting To Trans. (Lower)  
 GMC; Yukon; 2003; V-8 6.0 Eng.; Outlet Fitting To Trans. (Lower)

## A63006 - Continued

GMC; Yukon; 1997-1996; V-8 6.5 Diesel Eng.; Inlet Fitting To Trans. (Upper); W/Fact Fitting  
 GMC; Yukon; 1997-1994; V-8 6.5 Diesel Eng.; Outlet Fitting To Trans. (Lower)  
 GMC; Yukon; 1995-1994; V-8 6.5 Diesel Eng.; Inlet Fitting To Trans. (Upper)  
 GMC; Yukon; 2002-2001; V-8 8.1 Eng.; Connector From Rad; 2 Req'd  
 Olds; Achieva; 1995-1994; 4-Cyl. 2.3 Eng.; Inlet Fitting To Trans. (Upper); W/3-Spd Trans.  
 Olds; Achieva; 1995-1994; 4-Cyl. 2.3 Eng.; Outlet Fitting To Trans. (Lower); W/3-Spd Trans.  
 Olds; Achieva; 1993-1992; 4-Cyl. 2.3 Eng.; Inlet Fitting To Trans. (Upper)  
 Olds; Achieva; 1993-1992; 4-Cyl. 2.3 Eng.; Outlet Fitting To Trans. (Lower)  
 Olds; Achieva; 1993-1992; V-6 3.3 Eng.; Inlet Fitting To Trans. (Upper)  
 Olds; Achieva; 1993-1992; V-6 3.3 Eng.; Outlet Fitting To Trans. (Lower)  
 Olds; Bravada; 1994-1991; V-6 4.3 Eng.; Connector From Rad; 2 Req'd  
 Olds; Bravada; 1994-1991; V-6 4.3 Eng.; Inlet Fitting To Trans. (Lower)  
 Olds; Bravada; 1994-1991; V-6 4.3 Eng.; Outlet Fitting To Trans. (Upper)  
 Olds; Custom Cruiser; 1992-1988; V-8 5.0 Eng.; Inlet Fitting To Trans. (Upper)  
 Olds; Custom Cruiser; 1992-1988; V-8 5.0 Eng.; Outlet Fitting To Trans. (Lower)  
 Olds; Cutlass Calais; 1991-1988; 4-Cyl. 2.3 Eng.; Inlet Fitting To Trans. (Upper)  
 Olds; Cutlass Calais; 1991-1988; 4-Cyl. 2.3 Eng.; Outlet Fitting To Trans. (Lower)  
 Olds; Cutlass Calais; 1991-1988; 4-Cyl. 2.5 Eng.; Inlet Fitting To Trans. (Upper)  
 Olds; Cutlass Calais; 1991-1988; 4-Cyl. 2.5 Eng.; Outlet Fitting To Trans. (Lower)  
 Olds; Cutlass Calais; 1988; V-6 3.0 Eng.; Inlet Fitting To Trans. (Upper)  
 Olds; Cutlass Calais; 1988; V-6 3.0 Eng.; Outlet Fitting To Trans. (Lower)  
 Olds; Cutlass Calais; 1991-1989; V-6 3.3 Eng.; Inlet Fitting To Trans. (Upper)  
 Olds; Cutlass Calais; 1991-1989; V-6 3.3 Eng.; Outlet Fitting To Trans. (Lower)  
 Olds; Cutlass Ciera; 1996-1993; 4-Cyl. 2.2 Eng.; Inlet Fitting To Trans. (Upper)  
 Olds; Cutlass Ciera; 1996-1993; 4-Cyl. 2.2 Eng.; Outlet Fitting To Trans. (Lower)  
 Olds; Cutlass Ciera; 1992-1988; 4-Cyl. 2.5 Eng.; Inlet Fitting To Trans. (Upper)  
 Olds; Cutlass Ciera; 1992-1988; 4-Cyl. 2.5 Eng.; Outlet Fitting To Trans. (Lower)  
 Olds; Cutlass Ciera; 1989-1988; V-6 2.8 Eng.; Inlet Fitting To Trans. (Upper)  
 Olds; Cutlass Ciera; 1989-1988; V-6 2.8 Eng.; Outlet Fitting To Trans. (Lower); W/3-Spd Trans.  
 Olds; Cutlass Ciera; 1993-1989; V-6 3.3 Eng.; Inlet Fitting To Trans. (Upper)  
 Olds; Cutlass Ciera; 1989; V-6 3.3 Eng.; Outlet Fitting To Trans. (Lower); W/3-Spd Trans.  
 Olds; Cutlass Ciera; 1988; V-6 3.8 Eng.; Inlet Fitting To Trans. (Upper)  
 Olds; Cutlass Ciera; 1988; V-6 3.8 Eng.; Outlet Fitting To Trans. (Lower); W/3-Spd Trans.  
 Olds; Cutlass Cruiser; 1990; 4-Cyl. 2.5 Eng.; Inlet Fitting To Trans. (Upper)  
 Olds; Cutlass Cruiser; 1990; 4-Cyl. 2.5 Eng.; Outlet Fitting To Trans. (Lower)  
 Olds; Cutlass Cruiser; 1994; V-6 3.1 Eng.; Inlet Fitting To Trans. (Upper)  
 Olds; Cutlass Cruiser; 1993-1990; V-6 3.3 Eng.; Inlet Fitting To Trans. (Upper)  
 Olds; Cutlass Supreme; 1991-1990; 4-Cyl. 2.3 Eng.; Inlet Fitting To Trans. (Upper)  
 Olds; Cutlass Supreme; 1991-1990; 4-Cyl. 2.3 Eng.; Outlet Fitting To Trans. (Lower)  
 Olds; Cutlass Supreme; 1989-1988; V-6 2.8 Eng.; Inlet Fitting To Trans. (Upper)  
 Olds; Cutlass Supreme; 1989-1988; V-6 2.8 Eng.; Outlet Fitting To Trans. (Lower)  
 Olds; Cutlass Supreme; 1993-1991; V-6 3.1 Eng.; Inlet Fitting To Trans. (Upper); W/3-Spd Trans.  
 Olds; Cutlass Supreme; 1993-1991; V-6 3.1 Eng.; Outlet Fitting To Trans. (Lower); W/3-Spd Trans.  
 Olds; Cutlass Supreme; 1990-1989; V-6 3.1 Eng.; Inlet Fitting To Trans. (Upper)  
 Olds; Cutlass Supreme; 1990-1989; V-6 3.1 Eng.; Outlet Fitting To Trans. (Lower)  
 Olds; Cutlass Supreme; 1993-1991; V-6 3.4 Eng.; Inlet Fitting To Trans. (Upper); W/3-Spd Trans.  
 Olds; Cutlass Supreme; 1993-1991; V-6 3.4 Eng.; Outlet Fitting To Trans. (Lower); W/3-Spd Trans.  
 Olds; Cutlass Supreme; 1988; V-8 5.0 Eng.; Inlet Fitting To Trans. (Upper)

# Numerical Listing - Oil Cooler Assemblies & End Fittings

## A63006 - Continued

Olds; Cutlass Supreme; 1988; V-8 5.0 Eng.; Outlet Fitting To Trans. (Lower)

Olds; Delta 88; 1988-1986; V-6 3.8 Eng.; Inlet Fitting To Trans. (Upper)

Olds; Delta 88; 1988-1986; V-6 3.8 Eng.; Outlet Fitting To Trans. (Lower)

Olds; Eighty Eight; 1990-1989; V-6 3.8 Eng.; Inlet Fitting To Trans. (Upper)

Olds; Firenza; 1986-1985; 4-Cyl. 1.8 Eng.; Inlet Fitting To Trans. (Upper)

Olds; Firenza; 1986-1985; 4-Cyl. 1.8 Eng.; Outlet Fitting To Trans. (Lower)

Olds; Firenza; 1988-1985; 4-Cyl. 2.0 Eng.; Inlet Fitting To Trans. (Upper)

Olds; Firenza; 1988-1985; 4-Cyl. 2.0 Eng.; Outlet Fitting To Trans. (Lower)

Olds; Firenza; 1987-1985; V-6 2.8 Eng.; Inlet Fitting To Trans. (Upper)

Olds; Firenza; 1987-1985; V-6 2.8 Eng.; Outlet Fitting To Trans. (Lower)

Olds; Ninety Eight; 1990-1986; V-6 3.8 Eng.; Inlet Fitting To Trans. (Upper)

Olds; Silhouette; 1994-1990; V-6 3.1 Eng.; Inlet Fitting To Trans. (Upper)

Olds; Silhouette; 1994-1990; V-6 3.1 Eng.; Outlet Fitting To Trans. (Lower)

Olds; Toronado; 1990-1986; V-6 3.8 Eng.; Inlet Fitting To Trans. (Lower);  
2 Reqd

Pont; Bonneville; 1990-1986; V-6 3.8 Eng.; Inlet Fitting To Trans. (Upper)

Pont; Bonneville; 1986; V-6 3.8 Eng.; Outlet Fitting To Trans. (Lower);  
W/3-Spd Trans.

Pont; Firebird; 1989-1988; V-6 2.8 Eng.; Inlet Fitting To Trans. (Upper)

Pont; Firebird; 1989-1988; V-6 2.8 Eng.; Outlet Fitting To Trans. (Lower)

Pont; Firebird; 1992-1990; V-6 3.1 Eng.; Inlet Fitting To Trans. (Upper)

Pont; Firebird; 1992-1990; V-6 3.1 Eng.; Outlet Fitting To Trans. (Lower)

Pont; Firebird; 1995-1993; V-6 3.4 Eng.; Inlet Fitting To Trans. (Upper)

Pont; Firebird; 1995-1993; V-6 3.4 Eng.; Outlet Fitting To Trans. (Lower)

Pont; Firebird; 1997-1995; V-6 3.8 Eng.; Inlet Fitting To Trans. (Upper)

Pont; Firebird; 1997-1995; V-6 3.8 Eng.; Outlet Fitting To Trans. (Lower)

Pont; Firebird; 1992-1988; V-8 5.0 Eng.; Inlet Fitting To Trans. (Upper)

Pont; Firebird; 1992-1988; V-8 5.0 Eng.; Outlet Fitting To Trans. (Lower)

Pont; Firebird; 1997-1988; V-8 5.7 Eng.; Inlet Fitting To Trans. (Upper)

Pont; Firebird; 1997-1988; V-8 5.7 Eng.; Outlet Fitting To Trans. (Lower)

Pont; Grand Am; 1989-1988; 4-Cyl. 2.0 Eng.; Inlet Fitting To Trans. (Upper)

Pont; Grand Am; 1989-1988; 4-Cyl. 2.0 Eng.; Outlet Fitting To Trans. (Lower)

Pont; Grand Am; 1995-1994; 4-Cyl. 2.3 Eng.; Inlet Fitting To Trans. (Upper);  
W/3-Spd Trans.

Pont; Grand Am; 1995-1994; 4-Cyl. 2.3 Eng.; Outlet Fitting To Trans. (Lower);  
W/3-Spd Trans.

Pont; Grand Am; 1993-1988; 4-Cyl. 2.3 Eng.; Inlet Fitting To Trans. (Upper)

Pont; Grand Am; 1993-1988; 4-Cyl. 2.3 Eng.; Outlet Fitting To Trans. (Lower)

Pont; Grand Am; 1991-1988; 4-Cyl. 2.5 Eng.; Inlet Fitting To Trans. (Upper)

Pont; Grand Am; 1991-1988; 4-Cyl. 2.5 Eng.; Outlet Fitting To Trans. (Lower)

Pont; Grand Am; 1993-1992; V-6 3.3 Eng.; Inlet Fitting To Trans. (Upper)

Pont; Grand Am; 1993-1992; V-6 3.3 Eng.; Outlet Fitting To Trans. (Lower)

Pont; Grand Prix; 1991-1990; 4-Cyl. 2.3 Eng.; Inlet Fitting To Trans. (Upper)

Pont; Grand Prix; 1991-1990; 4-Cyl. 2.3 Eng.; Outlet Fitting To Trans. (Lower)

Pont; Grand Prix; 1989-1988; V-6 2.8 Eng.; Inlet Fitting To Trans. (Upper);  
As Reqd

Pont; Grand Prix; 1989-1988; V-6 2.8 Eng.; Outlet Fitting To Trans. (Lower);  
As Reqd

Pont; Grand Prix; 1993-1991; V-6 3.1 Eng.; Inlet Fitting To Trans. (Upper);  
W/3-Spd Trans.

Pont; Grand Prix; 1993-1991; V-6 3.1 Eng.; Outlet Fitting To Trans. (Lower);  
W/3-Spd Trans.

Pont; Grand Prix; 1990-1989; V-6 3.1 Eng.; Inlet Fitting To Trans. (Upper);  
W/O Turbo; As Reqd

Pont; Grand Prix; 1990-1989; V-6 3.1 Eng.; Outlet Fitting To Trans. (Lower);  
As Reqd

Pont; Grand Prix; 1991; V-6 3.4 Eng.; Inlet Fitting To Trans. (Upper);  
W/3-Spd Trans.

Pont; Grand Prix; 1991; V-6 3.4 Eng.; Outlet Fitting To Trans. (Lower);  
W/3-Spd Trans.

Pont; Sunbird; 1986-1985; 4-Cyl. 1.8 Eng.; Inlet Fitting To Trans. (Upper);  
W/3-Spd Trans.

Pont; Sunbird; 1986-1985; 4-Cyl. 1.8 Eng.; Outlet Fitting To Trans. (Lower);  
W/3-Spd Trans.

Pont; Sunbird; 1994-1985; 4-Cyl. 2.0 Eng.; Inlet Fitting To Trans. (Upper);  
W/3-Spd Trans.

Pont; Sunbird; 1994-1985; 4-Cyl. 2.0 Eng.; Outlet Fitting To Trans. (Lower);  
W/3-Spd Trans.

Pont; Sunbird; 1994-1991; V-6 3.1 Eng.; Inlet Fitting To Trans. (Upper);  
W/3-Spd Trans.

Pont; Sunbird; 1994-1991; V-6 3.1 Eng.; Outlet Fitting To Trans. (Lower);  
W/3-Spd Trans.

## A63006 - Continued

Pont; Sunfire; 2001-1995; 4-Cyl. 2.2 Eng.; Inlet Fitting To Trans. (Upper);  
W/3-Spd Trans.

Pont; Sunfire; 2001-1995; 4-Cyl. 2.2 Eng.; Outlet Fitting To Trans. (Lower);  
W/3-Spd Trans.

Pont; Trans Sport; 1995-1990; V-6 3.1 Eng.; Inlet Fitting To Trans. (Upper)

Pont; Trans Sport; 1995-1990; V-6 3.1 Eng.; Outlet Fitting To Trans. (Lower)

Pont; 6000; 1991-1985; 4-Cyl. 2.5 Eng.; Inlet Fitting To Trans. (Upper)

Pont; 6000; 1991-1985; 4-Cyl. 2.5 Eng.; Outlet Fitting To Trans. (Lower)

Pont; 6000; 1989-1985; V-6 2.8 Eng.; Inlet Fitting To Trans. (Upper)

Pont; 6000; 1989-1985; V-6 2.8 Eng.; Outlet Fitting To Trans. (Lower);  
W/3-Spd Trans.

Pont; 6000; 1991-1988; V-6 3.1 Eng.; Inlet Fitting To Trans. (Upper)

Pont; 6000; 1989-1988; V-6 3.1 Eng.; Outlet Fitting To Trans. (Lower);  
W/3-Spd Trans.

## A63007

Buick; Century; 1999-1994; V-6 3.1 Eng.; Inlet Fitting To Trans. (Upper)

Buick; Lesabre; 1999-1994; V-6 3.8 Eng.; Inlet Fitting To Trans. (Upper)

Buick; Lesabre; 1993-1991; V-6 3.8 Eng.; Inlet Fitting To Trans. (Lower)

Buick; Park Ave.; 1999-1994; V-6 3.8 Eng.; Inlet Fitting To Trans. (Upper)

Buick; Park Ave.; 1993-1991; V-6 3.8 Eng.; Inlet Fitting To Trans. (Lower)

Buick; Reatta; 1991; V-6 3.8 Eng.; Inlet Fitting To Trans. (Lower)

Buick; Regal; 1996-1992; V-6 3.1 Eng.; Inlet Fitting To Trans. (Upper)

Buick; Regal; 1991; V-6 3.1 Eng.; Inlet Fitting To Trans. (Upper); W/3"8"  
Tubing

Buick; Regal; 1999-1990; V-6 3.8 Eng.; Inlet Fitting To Trans. (Upper)

Buick; Riviera; 1999-1995; V-6 3.8 Eng.; Inlet Fitting To Trans. (Lower)

Buick; Riviera; 1993-1991; V-6 3.8 Eng.; Inlet Fitting To Trans. (Lower)

Buick; Roadmaster; 1996-1994; V-8 5.7 Eng.; Inlet Fitting To Trans. (Upper)

Buick; Roadmaster; 1996-1994; V-8 5.7 Eng.; Outlet Fitting To Trans. (Lower)

Buick; Skylark; 1995-1994; 4-Cyl. 2.3 Eng.; Inlet Fitting To Trans. (Upper);  
W/4-Spd Trans.

Buick; Skylark; 1998-1996; 4-Cyl. 2.4 Eng.; Inlet Fitting To Trans. (Upper)

Buick; Skylark; 1998-1994; V-6 3.1 Eng.; Inlet Fitting To Trans. (Upper)

Cad; Allante; 1992-1990; V-8 4.5 Eng.; Inlet Fitting To Trans. (Upper)

Cad; Deville; 1995-1991; V-8 4.9 Eng.; Inlet Fitting To Trans. (Lower)

Cad; Eldorado; 1993-1991; V-8 4.9 Eng.; Inlet Fitting To Trans. (Lower)

Cad; Escalade; 2000-1999; V-8 5.7 Eng.; Inlet Fitting To Trans. (Upper)

Cad; Escalade; 2000-1999; V-8 5.7 Eng.; Outlet Fitting To Trans. (Lower)

Cad; Fleetwood; 1992-1991; V-8 4.9 Eng.; Inlet Fitting To Trans. (Lower)

Cad; Fleetwood; 1996-1994; V-8 5.7 Eng.; Inlet Fitting To Trans. (Lower)

Cad; Fleetwood; 1996-1994; V-8 5.7 Eng.; Outlet Fitting To Trans. (Upper)

Cad; Seville; 1993; V-8 4.6 Eng.; Inlet Fitting To Trans. (Upper)

Cad; Seville; 1993-1991; V-8 4.9 Eng.; Inlet Fitting To Trans. (Lower)

Cad; Sixty Special; 1993; V-8 4.9 Eng.; Inlet Fitting To Trans. (Lower)

Chev; Beretta; 1994; 4-Cyl. 2.3 Eng.; Inlet Fitting To Trans. (Upper);  
W/4-Spd Trans.

Chev; Beretta; 1996-1994; V-6 3.1 Eng.; Inlet Fitting To Trans. (Upper)

Chev; C&K Pickup; 1998; V-6 4.3 Eng.; Inlet Fitting To Trans. (Upper)

Chev; C&K Pickup; 1998; V-6 4.3 Eng.; Outlet Fitting To Trans. (Lower)

Chev; C&K Pickup; 1997-1996; V-6 4.3 Eng.; Inlet Fitting To Trans. (Upper);  
Service Item

Chev; C&K Pickup; 1997-1996; V-6 4.3 Eng.; Outlet Fitting To Trans. (Lower);  
Service Item

Chev; C&K Pickup; 1999-1998; V-8 5.0 Eng.; Inlet Fitting To Trans. (Upper)

Chev; C&K Pickup; 1999-1998; V-8 5.0 Eng.; Outlet Fitting To Trans. (Lower)

Chev; C&K Pickup; 1997-1996; V-8 5.0 Eng.; Inlet Fitting To Trans. (Upper);  
Service Item

Chev; C&K Pickup; 1997-1996; V-8 5.0 Eng.; Outlet Fitting To Trans. (Lower);  
Service Item

Chev; C&K Pickup; 2000-1996; V-8 5.7 Eng.; Inlet Fitting To Trans. (Upper);  
Service Item

Chev; C&K Pickup; 2000-1996; V-8 5.7 Eng.; Outlet Fitting To Trans. (Lower);  
W/16-Bolt Trans. Pan (M30)

Chev; C&K Pickup; 2000-1996; V-8 5.7 Eng.; Outlet Fitting To Trans. (Lower);  
W/16-Bolt Trans. Pan (M30)

Chev; C&K Pickup; 2002-1996; V-8 6.5 Diesel Eng.; Inlet Fitting To Trans. (Upper);  
Service Item

Chev; C&K Pickup; 1996; V-8 6.5 Diesel Eng.; Outlet Fitting To Trans. (Lower);  
Service Item

Chev; C&K Pickup; 2000-1997; V-8 7.4 Eng.; Inlet Fitting To Trans. (Upper);  
Service Item

Chev; C&K Pickup; 1996; V-8 7.4 Eng.; Inlet Fitting To Trans. (Upper)

Chev; C&K Pickup; 1996; V-8 7.4 Eng.; Outlet Fitting To Trans. (Upper)

Chev; C&K Pickup; 2002-2001; V-8 8.1 Eng.; Inlet Fitting To Trans. (Upper);  
Service Item

## Numerical Listing - Oil Cooler Assemblies & End Fittings

### A63007 - Continued

Chev; Caprice; 1996-1994; V-8 4.3 Eng.; Inlet Fitting To Trans. (Upper)  
 Chev; Caprice; 1996-1994; V-8 4.3 Eng.; Outlet Fitting To Trans. (Lower)  
 Chev; Caprice; 1996-1994; V-8 5.7 Eng.; Inlet Fitting To Trans. (Upper)  
 Chev; Caprice; 1996-1994; V-8 5.7 Eng.; Outlet Fitting To Trans. (Lower)  
 Chev; Corsica; 1996-1994; V-6 3.1 Eng.; Inlet Fitting To Trans. (Upper)  
 Chev; Corvette; 2003-1997; V-8 5.7 Eng.; Inlet Fitting To Trans. (Upper)  
 Chev; Corvette; 2003-1997; V-8 5.7 Eng.; Outlet Fitting To Trans. (Upper)  
 Chev; Express; 1996; V-6 4.3 Eng.; Inlet Fitting To Trans. Case (Upper)  
 Chev; Express; 1996; V-8 5.0 Eng.; Inlet Fitting To Trans. Case (Upper)  
 Chev; Express; 1996; V-8 5.7 Eng.; Inlet Fitting To Trans. Case (Upper)  
 Chev; Express; 1996; V-8 7.4 Eng.; Inlet Fitting To Trans. Case (Upper);  
 W/O Aux. Cooler  
 Chev; Express; 1996; V-8 7.4 Eng.; Outlet Fitting To Trans. Case (Lower);  
 W/O Aux. Cooler  
 Chev; Impala SS; 1996-1994; V-8 5.7 Eng.; Inlet Fitting To Trans. (Upper)  
 Chev; Impala SS; 1996-1994; V-8 5.7 Eng.; Outlet Fitting To Trans. (Lower)  
 Chev; Lumina; 1999-1994; V-6 3.1 Eng.; Inlet Fitting To Trans. (Upper)  
 Chev; Lumina; 1993-1991; V-6 3.1 Eng.; Inlet Fitting To Trans. (Upper);  
 W/4-Spd Trans.  
 Chev; Lumina; 1997-1994; V-6 3.4 Eng.; Inlet Fitting To Trans. (Upper)  
 Chev; Lumina; 1993-1991; V-6 3.4 Eng.; Inlet Fitting To Trans. (Upper);  
 W/4-Spd Trans.  
 Chev; Lumina; 1999-1998; V-6 3.8 Eng.; Inlet Fitting To Trans. (Upper)  
 Chev; Lumina APV; 1996; V-6 3.4 Eng.; Inlet Fitting To Trans. (Upper)  
 Chev; Lumina APV; 1995-1992; V-6 3.8 Eng.; Inlet Fitting To Trans. (Upper)  
 Chev; Monte Carlo; 1999-1995; V-6 3.1 Eng.; Inlet Fitting To Trans. (Upper)  
 Chev; Monte Carlo; 1997-1995; V-6 3.4 Eng.; Inlet Fitting To Trans. (Upper)  
 Chev; Monte Carlo; 1999-1998; V-6 3.8 Eng.; Inlet Fitting To Trans. (Upper)  
 Chev; Silverado Pickup; 1999; V-8 6.5 Diesel Eng.; Inlet Fitting To Trans.  
 (Upper); Service Item  
 Chev; Suburban; 1999-1996; V-8 5.7 Eng.; Inlet Fitting To Trans. (Upper);  
 Service Item  
 Chev; Suburban; 1999-1996; V-8 5.7 Eng.; Inlet Fitting To Trans. (Upper);  
 W/16-Bolt Trans. Pan (M30)  
 Chev; Suburban; 1999-1996; V-8 5.7 Eng.; Outlet Fitting To Trans. (Lower);  
 W/16-Bolt Trans. Pan (M30)  
 Chev; Suburban; 1999-1996; V-8 6.5 Diesel Eng.; Inlet Fitting To Trans.  
 (Upper); Service Item  
 Chev; Suburban; 1999-1996; V-8 7.4 Eng.; Inlet Fitting To Trans. (Upper);  
 Service Item  
 Chev; Tahoe; 2000-1998; V-8 5.7 Eng.; Inlet Fitting To Trans. (Upper)  
 Chev; Tahoe; 2000-1996; V-8 5.7 Eng.; Outlet Fitting To Trans. (Lower)  
 Chev; Tahoe; 1997-1996; V-8 5.7 Eng.; Inlet Fitting To Trans. (Upper);  
 Service Item  
 Chev; Tahoe; 1999-1996; V-8 6.5 Diesel Eng.; Inlet Fitting To Trans. (Upper);  
 Service Item  
 Chev; Venture; 1999-1997; V-6 3.4 Eng.; Inlet Fitting To Trans. (Lower)  
 GMC; C&K Pickup; 1998-1997; V-6 4.3 Eng.; Inlet Fitting To Trans. (Upper)  
 GMC; C&K Pickup; 1998-1997; V-6 4.3 Eng.; Outlet Fitting To Trans.  
 (Lower)  
 GMC; C&K Pickup; 1996; V-6 4.3 Eng.; Inlet Fitting To Trans. (Upper);  
 Service Item  
 GMC; C&K Pickup; 1996; V-6 4.3 Eng.; Outlet Fitting To Trans. (Lower);  
 Service Item  
 GMC; C&K Pickup; 1999-1998; V-8 5.0 Eng.; Inlet Fitting To Trans. (Upper)  
 GMC; C&K Pickup; 1999-1998; V-8 5.0 Eng.; Outlet Fitting To Trans.  
 (Lower)  
 GMC; C&K Pickup; 1997-1996; V-8 5.0 Eng.; Inlet Fitting To Trans. (Upper);  
 Service Item  
 GMC; C&K Pickup; 1997-1996; V-8 5.0 Eng.; Outlet Fitting To Trans.  
 (Lower); Service Item  
 GMC; C&K Pickup; 2000-1996; V-8 5.7 Eng.; Inlet Fitting To Trans. (Upper);  
 Service Item  
 GMC; C&K Pickup; 2000-1996; V-8 5.7 Eng.; Outlet Fitting To Trans. (Upper);  
 W/16-Bolt Trans. Pan (M30)  
 GMC; C&K Pickup; 2000-1996; V-8 5.7 Eng.; Inlet Fitting To Trans. (Upper);  
 W/16-Bolt Trans. Pan (M30)  
 GMC; C&K Pickup; 2002-1996; V-8 6.5 Diesel Eng.; Inlet Fitting To Trans.  
 (Upper); Service Item  
 GMC; C&K Pickup; 1996; V-8 6.5 Diesel Eng.; Outlet Fitting To Trans.  
 (Lower); Service Item  
 GMC; C&K Pickup; 2000-1996; V-8 7.4 Eng.; Inlet Fitting To Trans. (Upper);  
 Service Item  
 GMC; C&K Pickup; 1996; V-8 7.4 Eng.; Outlet Fitting To Trans. (Upper)  
 GMC; C&K Pickup; 2002-2001; V-8 8.1 Eng.; Inlet Fitting To Trans. (Upper);  
 Service Item  
 GMC; Savana; 1996; V-8 5.0 Eng.; Inlet Fitting To Trans. Case (Upper)

### A63007 - Continued

GMC; Savana; 1996; V-8 5.7 Eng.; Inlet Fitting To Trans. Case (Upper)  
 GMC; Savana; 1996; V-8 7.4 Eng.; Inlet Fitting To Trans. Case (Upper);  
 W/O Aux. Cooler  
 GMC; Savana; 1996; V-8 7.4 Eng.; Outlet Fitting To Trans. Case (Lower);  
 W/O Aux. Cooler  
 GMC; Sierra Pickup; 1999; V-8 6.5 Diesel Eng.; Inlet Fitting To Trans.  
 (Upper); Service Item  
 GMC; Suburban; 1999-1996; V-8 5.7 Eng.; Inlet Fitting To Trans. (Upper);  
 Service Item  
 GMC; Suburban; 1999-1996; V-8 5.7 Eng.; Inlet Fitting To Trans. (Upper);  
 W/16-Bolt Trans. Pan (M30)  
 GMC; Suburban; 1999-1996; V-8 5.7 Eng.; Outlet Fitting To Trans. (Lower);  
 W/16-Bolt Trans. Pan (M30)  
 GMC; Suburban; 1999-1996; V-8 6.5 Diesel Eng.; Inlet Fitting To Trans.  
 (Upper); Service Item  
 GMC; Suburban; 1999-1996; V-8 7.4 Eng.; Inlet Fitting To Trans. (Upper);  
 Service Item  
 GMC; Yukon; 2000; V-8 5.7 Eng.; Inlet Fitting To Trans. (Upper)  
 GMC; Yukon; 2000; V-8 5.7 Eng.; Outlet Fitting To Trans. (Lower)  
 GMC; Yukon; 1999-1996; V-8 5.7 Eng.; Inlet Fitting To Trans. (Upper);  
 Service Item  
 GMC; Yukon; 1999-1996; V-8 5.7 Eng.; Inlet Fitting To Trans. (Upper);  
 W/16-Bolt Trans. Pan (M30)  
 GMC; Yukon; 1999-1996; V-8 5.7 Eng.; Outlet Fitting To Trans. (Lower);  
 W/16-Bolt Trans. Pan (M30)  
 GMC; Yukon; 1997-1996; V-8 6.5 Diesel Eng.; Inlet Fitting To Trans. (Upper);  
 Service Item  
 Olds; Achieva; 1995-1994; 4-Cyl. 2.3 Eng.; Inlet Fitting To Trans. (Upper);  
 W/4-Spd Trans.  
 Olds; Achieva; 1998-1997; 4-Cyl. 2.4 Eng.; Inlet Fitting To Trans. (Upper)  
 Olds; Achieva; 1998-1997; V-6 3.1 Eng.; Inlet Fitting To Trans. (Upper)  
 Olds; Achieva; 1995-1994; V-6 3.1 Eng.; Inlet Fitting To Trans. (Upper)  
 Olds; Cutlass Ciera; 1996-1994; V-6 3.1 Eng.; Inlet Fitting To Trans. (Upper)  
 Olds; Cutlass Supreme; 1997-1994; V-6 3.1 Eng.; Inlet Fitting To Trans.  
 (Upper)  
 Olds; Cutlass Supreme; 1993-1991; V-6 3.1 Eng.; Inlet Fitting To Trans.  
 (Upper); W/4-Spd Trans.  
 Olds; Cutlass Supreme; 1996-1994; V-6 3.4 Eng.; Inlet Fitting To Trans.  
 (Upper)  
 Olds; Cutlass Supreme; 1993-1991; V-6 3.4 Eng.; Inlet Fitting To Trans.  
 (Upper); W/4-Spd Trans.  
 Olds; Eighty Eight; 1999-1994; V-6 3.8 Eng.; Inlet Fitting To Trans. (Upper)  
 Olds; Eighty Eight; 1993-1991; V-6 3.8 Eng.; Inlet Fitting To Trans. (Lower)  
 Olds; Eighty Eight; 1993; V-6 3.8 Eng.; Outlet Fitting To Trans. (Lower)  
 Olds; Intrigue; 1999; V-6 3.5 Eng.; Inlet Fitting To Trans. (Upper)  
 Olds; Intrigue; 1999-1998; V-6 3.8 Eng.; Inlet Fitting To Trans. (Upper)  
 Olds; Ninety Eight; 1996-1993; V-6 3.8 Eng.; Inlet Fitting To Trans. (Upper)  
 Olds; Ninety Eight; 1992-1991; V-6 3.8 Eng.; Inlet Fitting To Trans. (Lower)  
 Olds; Regency; 1998-1997; V-6 3.8 Eng.; Inlet Fitting To Trans. (Upper)  
 Olds; Silhouette; 1999-1997; V-6 3.4 Eng.; Inlet Fitting To Trans. (Lower)  
 Olds; Silhouette; 1996; V-6 3.4 Eng.; Inlet Fitting To Trans. (Upper)  
 Olds; Silhouette; 1995-1992; V-6 3.8 Eng.; Inlet Fitting To Trans. (Upper)  
 Olds; Toronado; 1992-1991; V-6 3.8 Eng.; Inlet Fitting To Trans. (Lower)  
 Pont; Bonneville; 1999-1994; V-6 3.8 Eng.; Inlet Fitting To Trans. (Upper)  
 Pont; Bonneville; 1993-1991; V-6 3.8 Eng.; Inlet Fitting To Trans. (Lower)  
 Pont; Grand Am; 1995-1994; 4-Cyl. 2.3 Eng.; Inlet Fitting To Trans. (Upper);  
 W/4-Spd Trans.  
 Pont; Grand Am; 1998-1996; 4-Cyl. 2.4 Eng.; Inlet Fitting To Trans. (Upper);  
 W/O Check Ball  
 Pont; Grand Am; 1998-1994; V-6 3.1 Eng.; Inlet Fitting To Trans. (Upper)  
 Pont; Grand Am; 1998-1996; V-6 3.1 Eng.; Outlet Fitting To Trans. (Lower);  
 W/O Check Ball  
 Pont; Grand Prix; 1999-1994; V-6 3.1 Eng.; Inlet Fitting To Trans. (Upper)  
 Pont; Grand Prix; 1993-1991; V-6 3.1 Eng.; Inlet Fitting To Trans. (Upper);  
 W/4-Spd Trans.  
 Pont; Grand Prix; 1990-1989; V-6 3.1 Eng.; Inlet Fitting To Trans. Case  
 (Upper); W/Turbo  
 Pont; Grand Prix; 1996-1992; V-6 3.4 Eng.; Inlet Fitting To Trans. (Upper)  
 Pont; Grand Prix; 1991; V-6 3.4 Eng.; Inlet Fitting To Trans. (Upper);  
 W/4-Spd Trans.  
 Pont; Grand Prix; 1999-1997; V-6 3.8 Eng.; Inlet Fitting To Trans. (Upper)  
 Pont; Montana; 1999; V-6 3.4 Eng.; Inlet Fitting To Trans. (Lower)  
 Pont; Trans Sport; 1998-1996; V-6 3.4 Eng.; Inlet Fitting To Trans. (Lower)  
 Pont; Trans Sport; 1995-1992; V-6 3.8 Eng.; Inlet Fitting To Trans. (Upper);  
 W/O Check Ball

Product Section

Troubleshooting

EOC Applications

TOC Applications

Numerical Listing

Manufacturers' Part Numbers

End Fittings

Illustrations

# Numerical Listing - Oil Cooler Assemblies & End Fittings

## A63008

Buick; Century; 1999-1994; V-6 3.1 Eng.; Outlet Fitting To Trans. (Lower)  
 Buick; Lesabre; 1997-1994; V-6 3.8 Eng.; Outlet Fitting To Trans. (Lower)  
 Buick; Lesabre; 1993-1991; V-6 3.8 Eng.; Outlet Fitting To Trans. (Upper)  
 Buick; Park Ave.; 1995-1994; V-6 3.8 Eng.; Outlet Fitting To Trans. (Lower)  
 Buick; Park Ave.; 1993-1991; V-6 3.8 Eng.; Outlet Fitting To Trans. (Upper)  
 Buick; Reatta; 1991; V-6 3.8 Eng.; Outlet Fitting To Trans. (Upper)  
 Buick; Regal; 1996-1992; V-6 3.1 Eng.; Outlet Fitting To Trans. (Lower)  
 Buick; Regal; 1991; V-6 3.1 Eng.; Outlet Fitting To Trans. (Lower); W/3/8" Tubing  
 Buick; Regal; 1997; V-6 3.8 Eng.; Outlet Fitting To Trans. (Lower); VIN K  
 Buick; Regal; 1996-1990; V-6 3.8 Eng.; Outlet Fitting To Trans. (Lower)  
 Buick; Riviera; 1996-1995; V-6 3.8 Eng.; Outlet Fitting To Trans. (Upper)  
 Buick; Riviera; 1993-1991; V-6 3.8 Eng.; Outlet Fitting To Trans. (Upper)  
 Buick; Skylark; 1995-1994; 4-Cyl. 2.3 Eng.; Outlet Fitting To Trans. (Lower); W/4-Spd Trans.  
 Buick; Skylark; 1998-1996; 4-Cyl. 2.4 Eng.; Outlet Fitting To Trans. (Lower)  
 Buick; Skylark; 1998-1994; V-6 3.1 Eng.; Outlet Fitting To Trans. (Lower)  
 Cad; Allante; 1992-1990; V-8 4.5 Eng.; Outlet Fitting To Trans. (Lower)  
 Cad; Deville; 1995-1991; V-8 4.9 Eng.; Outlet Fitting To Trans. (Upper)  
 Cad; Eldorado; 1993-1991; V-8 4.9 Eng.; Outlet Fitting To Trans. (Upper)  
 Cad; Fleetwood; 1992-1991; V-8 4.9 Eng.; Outlet Fitting To Trans. (Upper)  
 Cad; Seville; 1993; V-8 4.6 Eng.; Outlet Fitting To Trans. (Lower)  
 Cad; Seville; 1993-1991; V-8 4.9 Eng.; Outlet Fitting To Trans. (Upper)  
 Cad; Sixty Special; 1993; V-8 4.9 Eng.; Outlet Fitting To Trans. (Upper)  
 Chev; Beretta; 1994; 4-Cyl. 2.3 Eng.; Outlet Fitting To Trans. (Lower); W/4-Spd Trans.  
 Chev; Beretta; 1996-1994; V-6 3.1 Eng.; Outlet Fitting To Trans. (Lower)  
 Chev; Corsica; 1996-1994; V-6 3.1 Eng.; Outlet Fitting To Trans. (Lower)  
 Chev; Lumina; 1999-1994; V-6 3.1 Eng.; Outlet Fitting To Trans. (Lower)  
 Chev; Lumina; 1993-1991; V-6 3.1 Eng.; Outlet Fitting To Trans. (Lower); W/4-Spd Trans.  
 Chev; Lumina; 1997-1994; V-6 3.4 Eng.; Outlet Fitting To Trans. (Lower)  
 Chev; Lumina; 1993-1991; V-6 3.4 Eng.; Outlet Fitting To Trans. (Lower); W/4-Spd Trans.  
 Chev; Lumina; 1999-1998; V-6 3.8 Eng.; Outlet Fitting To Trans. (Lower)  
 Chev; Lumina APV; 1996; V-6 3.4 Eng.; Outlet Fitting To Trans. (Lower)  
 Chev; Lumina APV; 1995-1992; V-6 3.8 Eng.; Outlet Fitting To Trans. (Lower)  
 Chev; Monte Carlo; 1999-1995; V-6 3.1 Eng.; Outlet Fitting To Trans. (Lower)  
 Chev; Monte Carlo; 1997-1995; V-6 3.4 Eng.; Outlet Fitting To Trans. (Lower)  
 Chev; Monte Carlo; 1999-1998; V-6 3.8 Eng.; Outlet Fitting To Trans. (Lower)  
 Olds; Achieva; 1995-1994; 4-Cyl. 2.3 Eng.; Outlet Fitting To Trans. (Lower); W/4-Spd Trans.  
 Olds; Achieva; 1998-1997; 4-Cyl. 2.4 Eng.; Outlet Fitting To Trans. (Lower)  
 Olds; Achieva; 1998-1997; V-6 3.1 Eng.; Outlet Fitting To Trans. (Lower)  
 Olds; Achieva; 1995-1994; V-6 3.1 Eng.; Outlet Fitting To Trans. (Lower)  
 Olds; Cutlass Ciera; 1996-1994; V-6 3.1 Eng.; Outlet Fitting To Trans. (Lower)  
 Olds; Cutlass Supreme; 1997-1994; V-6 3.1 Eng.; Outlet Fitting To Trans. (Lower)  
 Olds; Cutlass Supreme; 1993-1991; V-6 3.1 Eng.; Outlet Fitting To Trans. (Lower); W/4-Spd Trans.  
 Olds; Cutlass Supreme; 1996-1994; V-6 3.4 Eng.; Outlet Fitting To Trans. (Lower)  
 Olds; Cutlass Supreme; 1993-1991; V-6 3.4 Eng.; Outlet Fitting To Trans. (Lower); W/4-Spd Trans.  
 Olds; Eighty Eight; 1997-1994; V-6 3.8 Eng.; Outlet Fitting To Trans. (Lower)  
 Olds; Eighty Eight; 1993; V-6 3.8 Eng.; Inlet Fitting To Trans. (Upper)  
 Olds; Eighty Eight; 1993-1991; V-6 3.8 Eng.; Outlet Fitting To Trans. (Upper)  
 Olds; Intrigue; 1999; V-6 3.5 Eng.; Outlet Fitting To Trans. (Lower); W/Check Ball  
 Olds; Intrigue; 1999-1998; V-6 3.8 Eng.; Outlet Fitting To Trans. (Lower); W/Check Ball  
 Olds; Ninety Eight; 1996-1993; V-6 3.8 Eng.; Outlet Fitting To Trans. (Lower)  
 Olds; Ninety Eight; 1992-1991; V-6 3.8 Eng.; Outlet Fitting To Trans. (Upper)  
 Olds; Regency; 1997; V-6 3.8 Eng.; Outlet Fitting To Trans. (Lower)  
 Olds; Silhouette; 1996; V-6 3.4 Eng.; Outlet Fitting To Trans. (Lower)  
 Olds; Silhouette; 1995-1992; V-6 3.8 Eng.; Outlet Fitting To Trans. (Lower)  
 Olds; Toronado; 1992-1991; V-6 3.8 Eng.; Outlet Fitting To Trans. (Upper)  
 Pont; Bonneville; 1997-1994; V-6 3.8 Eng.; Outlet Fitting To Trans. (Lower)

## A63008 - Continued

Pont; Bonneville; 1993-1991; V-6 3.8 Eng.; Outlet Fitting To Trans. (Upper)  
 Pont; Grand Am; 1995-1994; 4-Cyl. 2.3 Eng.; Outlet Fitting To Trans. (Lower); W/4-Spd Trans.  
 Pont; Grand Am; 1998-1996; 4-Cyl. 2.4 Eng.; Outlet Fitting To Trans. (Lower); W/Check Ball  
 Pont; Grand Am; 1998-1996; V-6 3.1 Eng.; Outlet Fitting To Trans. (Lower); W/Check Ball  
 Pont; Grand Am; 1995-1994; V-6 3.1 Eng.; Outlet Fitting To Trans. (Lower)  
 Pont; Grand Prix; 1999-1994; V-6 3.1 Eng.; Outlet Fitting To Trans. (Lower)  
 Pont; Grand Prix; 1993-1991; V-6 3.1 Eng.; Outlet Fitting To Trans. (Lower); W/4-Spd Trans.  
 Pont; Grand Prix; 1990-1989; V-6 3.1 Eng.; Inlet Fitting To Trans. (Upper); W/Check Ball  
 Pont; Grand Prix; 1996-1992; V-6 3.4 Eng.; Outlet Fitting To Trans. (Lower)  
 Pont; Grand Prix; 1991; V-6 3.4 Eng.; Outlet Fitting To Trans. (Lower); W/4-Spd Trans.  
 Pont; Grand Prix; 1999-1997; V-6 3.8 Eng.; Outlet Fitting To Trans. (Lower)  
 Pont; Trans Sport; 1998-1996; V-6 3.4 Eng.; Outlet Fitting To Trans. (Upper)  
 Pont; Trans Sport; 1995-1992; V-6 3.8 Eng.; Outlet Fitting To Trans. (Lower)

## A63011

Buick; Century; 1993; 4-Cyl. 2.2 Eng.; Tube Nut; W/Aux. Cooler; 6 Reqd  
 Buick; Century; 1993; 4-Cyl. 2.2 Eng.; Tube Nut; W/O Aux. Cooler; 4 Reqd  
 Buick; Century; 1992-1990; 4-Cyl. 2.5 Eng.; Tube Nut; W/Aux. Cooler; 6 Reqd  
 Buick; Century; 1992-1990; 4-Cyl. 2.5 Eng.; Tube Nut; W/O Aux. Cooler; 4 Reqd  
 Buick; Century; 1989-1988; 4-Cyl. 2.5 Eng.; Tube Nut; 4 Reqd  
 Buick; Century; 1989-1988; V-6 2.8 Eng.; Tube Nut; 4 Reqd  
 Buick; Century; 1996-1994; V-6 3.1 Eng.; Tube Nut; 2 Reqd  
 Buick; Century; 1993-1990; V-6 3.3 Eng.; Tube Nut; W/Aux. Cooler; 6 Reqd  
 Buick; Century; 1993-1990; V-6 3.3 Eng.; Tube Nut; W/O Aux. Cooler; 4 Reqd  
 Buick; Century; 1989; V-6 3.3 Eng.; Tube Nut; 4 Reqd  
 Buick; Century; 1988; V-6 3.8 Eng.; Tube Nut; 4 Reqd  
 Buick; Electra; 1990-1988; V-6 3.8 Eng.; Tube Nut; As Reqd  
 Buick; Electra; 1989-1986; V-8 5.0 Eng.; Tube Nut; As Reqd  
 Buick; Lesabre; 1990-1988; V-8 5.0 Eng.; Tube Nut; As Reqd  
 Buick; Reatta; 1990-1988; V-6 3.8 Eng.; Tube Nut; As Reqd  
 Buick; Regal; 1989-1988; V-6 2.8 Eng.; Tube Nut; As Reqd  
 Buick; Regal; 1991; V-6 3.1 Eng.; Tube Nut; W/5/16" Tubing; As Reqd  
 Buick; Regal; 1990-1989; V-6 3.1 Eng.; Tube Nut; As Reqd  
 Buick; Riviera; 1990-1986; V-6 3.8 Eng.; Tube Nut; As Reqd  
 Buick; Roadmaster; 1991; V-8 5.0 Eng.; Tube Nut To Trans. (Upper)  
 Buick; Roadmaster; 1991; V-8 5.0 Eng.; Tube Nuts From Rad  
 Buick; Roadmaster; 1993-1992; V-8 5.7 Eng.; Tube Nut To Trans. (Upper)  
 Buick; Roadmaster; 1993-1992; V-8 5.7 Eng.; Tube Nuts From Rad  
 Cad; Cimarron; 1986-1985; 4-Cyl. 2.0 Eng.; Tube Nut; As Reqd  
 Cad; Deville; 1990-1988; V-8 4.5 Eng.; Tube Nut; 2 Reqd  
 Cad; Eldorado; 1990; V-8 4.5 Eng.; Tube Nut; As Reqd  
 Cad; Fleetwood; 1990-1988; V-8 4.5 Eng.; Tube Nut; 2 Reqd  
 Cad; Fleetwood; 1993; V-8 5.7 Eng.; Tube Nut From Rad (Upper); 2 Reqd  
 Cad; Seville; 1990; V-8 4.5 Eng.; Tube Nut; As Reqd  
 Chev; Astro; 1990-1985; 4-Cyl. 2.5 Eng.; Tube Nut; 4 Reqd  
 Chev; Astro; 1994-1985; V-6 4.3 Eng.; Tube Nut; 4 Reqd  
 Chev; Blazer; 1995; V-6 4.3 Eng.; Tube Nut; 4 Reqd  
 Chev; Blazer Compact; 1988-1987; 4-Cyl. 2.5 Eng.; Tube Nut; 4 Reqd  
 Chev; Blazer Compact; 1989-1987; V-6 2.8 Eng.; Tube Nut; 4 Reqd  
 Chev; Blazer Compact; 1994-1988; V-6 4.3 Eng.; Tube Nut; 4 Reqd  
 Chev; Blazer Full Size; 1987; V-8 5.0 Eng.; Tube Nut; 4 Reqd  
 Chev; Blazer Full Size; 1994-1993; V-8 5.7 Eng.; Tube Nut; W/Aux. Cooler; 2 Reqd  
 Chev; Blazer Full Size; 1994-1993; V-8 5.7 Eng.; Tube Nut; W/O Aux. Cooler; 4 Reqd  
 Chev; Blazer Full Size; 1992-1987; V-8 5.7 Eng.; Tube Nut; 4 Reqd  
 Chev; Blazer Full Size; 1991-1987; V-8 6.2 Diesel Eng.; Tube Nut; As Reqd  
 Chev; Blazer Full Size; 1994; V-8 6.5 Diesel Eng.; Tube Nut; W/Aux. Cooler; 2 Reqd  
 Chev; Blazer Full Size; 1994; V-8 6.5 Diesel Eng.; Tube Nut; W/O Aux. Cooler; 4 Reqd  
 Chev; C&K Pickup; 1986-1985; 6-Cyl. 4.8 Eng.; Tube Nut; 4 Reqd  
 Chev; C&K Pickup; 1995-1988; V-6 4.3 Eng.; Tube Nut; 4 Reqd

Product Section

Troubleshooting

EOC Applications

TOC Applications

Numerical Listing

Manufacturers' Part Numbers

End Fittings

Illustrations

# Numerical Listing - Oil Cooler Assemblies & End Fittings

## A63011 - Continued

Chev; C&K Pickup; 1986-1985; V-6 4.3 Eng.; Tube Nut; 4 Reqd  
 Chev; C&K Pickup; 1995-1988; V-8 5.0 Eng.; Tube Nut; 4 Reqd  
 Chev; C&K Pickup; 1986-1985; V-8 5.0 Eng.; Tube Nut; 4 Reqd  
 Chev; C&K Pickup; 1995-1993; V-8 5.7 Eng.; Tube Nut; As Reqd  
 Chev; C&K Pickup; 1992-1988; V-8 5.7 Eng.; Tube Nut; 4 Reqd  
 Chev; C&K Pickup; 1986-1985; V-8 5.7 Eng.; Tube Nut; 4 Reqd  
 Chev; C&K Pickup; 1993-1988; V-8 6.2 Diesel Eng.; Tube Nut; 4 Reqd  
 Chev; C&K Pickup; 1986-1985; V-8 6.2 Diesel Eng.; Tube Nut; 4 Reqd  
 Chev; C&K Pickup; 1995-1993; V-8 6.5 Diesel Eng.; Tube Nut; As Reqd  
 Chev; C&K Pickup; 1992; V-8 6.5 Diesel Eng.; Tube Nut; 4 Reqd  
 Chev; C&K Pickup; 1995-1993; V-8 7.4 Eng.; Tube Nut; As Reqd  
 Chev; C&K Pickup; 1992-1988; V-8 7.4 Eng.; Tube Nut; 4 Reqd  
 Chev; C&K Pickup; 1986-1985; V-8 7.4 Eng.; Tube Nut; 4 Reqd  
 Chev; Camaro; 1986-1983; 4-Cyl. 2.5 Eng.; Tube Nut; 4 Reqd  
 Chev; Camaro; 1989-1983; V-6 2.8 Eng.; Tube Nut; 4 Reqd  
 Chev; Camaro; 1992-1990; V-6 3.1 Eng.; Tube Nut; 4 Reqd  
 Chev; Camaro; 1995-1993; V-6 3.4 Eng.; Tube Nut; As Reqd  
 Chev; Camaro; 1997-1995; V-6 3.8 Eng.; Tube Nut; As Reqd  
 Chev; Camaro; 1992-1983; V-8 5.0 Eng.; Tube Nut; 4 Reqd  
 Chev; Camaro; 1997-1993; V-8 5.7 Eng.; Tube Nut; As Reqd  
 Chev; Camaro; 1992-1987; V-8 5.7 Eng.; Tube Nut; 4 Reqd  
 Chev; Caprice; 1993-1992; V-6 4.3 Eng.; Tube Nut To Trans. (Upper)  
 Chev; Caprice; 1993; V-6 4.3 Eng.; Tube Nuts From Rad; 2 Reqd  
 Chev; Caprice; 1992; V-6 4.3 Eng.; Tube Nut From Rad; 2 Reqd  
 Chev; Caprice; 1990-1985; V-6 4.3 Eng.; Tube Nut From Rad; 2 Reqd  
 Chev; Caprice; 1990-1985; V-6 4.3 Eng.; Tube Nut To Trans. (Upper)  
 Chev; Caprice; 1993; V-8 5.0 Eng.; Tube Nut From Rad; W/O Aux. Cooler; 2 Reqd  
 Chev; Caprice; 1993; V-8 5.0 Eng.; Tube Nut To Trans. (Upper); W/O Aux. Cooler  
 Chev; Caprice; 1992-1985; V-8 5.0 Eng.; Tube Nut From Rad; 2 Reqd  
 Chev; Caprice; 1992-1985; V-8 5.0 Eng.; Tube Nut To Trans. (Upper)  
 Chev; Caprice; 1993; V-8 5.7 Eng.; Tube Nut From Rad; W/O Aux. Cooler; 2 Reqd  
 Chev; Caprice; 1993; V-8 5.7 Eng.; Tube Nut To Trans. (Upper); W/O Aux. Cooler  
 Chev; Caprice; 1992-1986; V-8 5.7 Eng.; Tube Nut From Rad; 2 Reqd  
 Chev; Caprice; 1992-1986; V-8 5.7 Eng.; Tube Nut To Trans. (Upper)  
 Chev; Caprice; 1985; V-8 5.7 Diesel Eng.; Tube Nut From Rad; 2 Reqd  
 Chev; Caprice; 1985; V-8 5.7 Diesel Eng.; Tube Nut To Trans. (Upper)  
 Chev; Celebrity; 1990-1985; 4-Cyl. 2.5 Eng.; Tube Nut; 4 Reqd  
 Chev; Celebrity; 1989-1985; V-6 2.8 Eng.; Tube Nut; 4 Reqd  
 Chev; Celebrity; 1990; V-6 3.1 Eng.; Tube Nut; 4 Reqd  
 Chev; Corvette; 1996-1984; V-8 5.7 Eng.; Tube Nut From Rad; 2 Reqd  
 Chev; El Camino; 1987-1986; V-6 4.3 Eng.; Tube Nut; 4 Reqd  
 Chev; El Camino; 1987-1986; V-8 5.0 Eng.; Tube Nut; 4 Reqd  
 Chev; G Van; 1996-1986; V-6 4.3 Eng.; Tube Nut; As Reqd  
 Chev; G Van; 1995-1986; V-8 5.0 Eng.; Tube Nut; As Reqd  
 Chev; G Van; 1996-1986; V-8 5.7 Eng.; Tube Nut; As Reqd  
 Chev; G Van; 1993-1986; V-8 6.2 Diesel Eng.; Tube Nut; As Reqd  
 Chev; G Van; 1996-1994; V-8 6.5 Diesel Eng.; Tube Nut; As Reqd  
 Chev; G Van; 1996-1988; V-8 7.4 Eng.; Tube Nut; As Reqd  
 Chev; Impala; 1985; V-6 4.3 Eng.; Tube Nut From Rad; 2 Reqd  
 Chev; Impala; 1985; V-6 4.3 Eng.; Tube Nut To Trans. (Upper)  
 Chev; Impala; 1985; V-8 5.0 Eng.; Tube Nut From Rad; 2 Reqd  
 Chev; Impala; 1985; V-8 5.0 Eng.; Tube Nut To Trans. (Upper)  
 Chev; Impala; 1985; V-8 5.7 Eng.; Tube Nut From Rad; 2 Reqd  
 Chev; Impala; 1985; V-8 5.7 Eng.; Tube Nut To Trans. (Upper)  
 Chev; Lumina; 1992-1990; 4-Cyl. 2.5 Eng.; Tube Nut; 4 Reqd  
 Chev; Lumina; 1993-1991; V-6 3.1 Eng.; Tube Nut; W/3-Spd Trans.; 4 Reqd  
 Chev; Lumina; 1990; V-6 3.1 Eng.; Tube Nut; 4 Reqd  
 Chev; Lumina APV; 1995-1990; V-6 3.1 Eng.; Tube Nut; As Reqd  
 Chev; Monte Carlo; 1984-1982; V-6 3.8 Eng.; Tube Nut From Rad; 2 Reqd  
 Chev; Monte Carlo; 1984-1982; V-6 3.8 Eng.; Tube Nut To Trans. (Upper)  
 Chev; Monte Carlo; 1988-1985; V-6 4.3 Eng.; Tube Nut From Rad; 2 Reqd  
 Chev; Monte Carlo; 1988-1985; V-6 4.3 Eng.; Tube Nut To Trans. (Upper)  
 Chev; Monte Carlo; 1988-1982; V-8 5.0 Eng.; Tube Nut From Rad; 2 Reqd  
 Chev; Monte Carlo; 1988-1982; V-8 5.0 Eng.; Tube Nut To Trans. (Upper)  
 Chev; R&V Pickup; 1988-1987; 6-Cyl. 4.8 Eng.; Tube Nut; 4 Reqd  
 Chev; R&V Pickup; 1987; V-6 4.3 Eng.; Tube Nut; 4 Reqd  
 Chev; R&V Pickup; 1991-1987; V-8 5.7 Eng.; Tube Nut; 4 Reqd  
 Chev; R&V Pickup; 1991-1987; V-8 6.2 Diesel Eng.; Tube Nut; 4 Reqd  
 Chev; R&V Pickup; 1991-1987; V-8 7.4 Eng.; Tube Nut; 4 Reqd  
 Chev; S Pickup; 1997-1994; 4-Cyl. 2.2 Eng.; Tube Nut; 4 Reqd  
 Chev; S Pickup; 1993-1986; 4-Cyl. 2.5 Eng.; Tube Nut; 4 Reqd  
 Chev; S Pickup; 1993-1986; V-6 2.8 Eng.; Tube Nut; 4 Reqd  
 Chev; S Pickup; 1995-1988; V-6 4.3 Eng.; Tube Nut; 4 Reqd  
 Chev; Suburban; 1987-1985; V-8 5.0 Eng.; Tube Nut; 4 Reqd

## A63011 - Continued

Chev; Suburban; 1995-1993; V-8 5.7 Eng.; Tube Nut; As Reqd  
 Chev; Suburban; 1992-1985; V-8 5.7 Eng.; Tube Nut; 4 Reqd  
 Chev; Suburban; 1991-1985; V-8 6.2 Diesel Eng.; Tube Nut; 4 Reqd  
 Chev; Suburban; 1995-1994; V-8 6.5 Diesel Eng.; Tube Nut; As Reqd  
 Chev; Suburban; 1995-1993; V-8 7.4 Eng.; Tube Nut; As Reqd  
 Chev; Suburban; 1992-1985; V-8 7.4 Eng.; Tube Nut; 4 Reqd  
 Chev; Tahoe; 1995; V-8 5.7 Eng.; Tube Nut; As Reqd  
 Chev; Tahoe; 1995; V-8 6.5 Diesel Eng.; Tube Nut; As Reqd  
 Ford; Bronco; 1992-1991; 6-Cyl. 4.9 Eng.; Tube Nut To Trans.; 2 Reqd  
 Ford; Bronco; 1996-1991; V-8 5.0 Eng.; Tube Nut To Trans.; 2 Reqd  
 Ford; Bronco; 1996-1991; V-8 5.8 Eng.; Tube Nut To Trans.; 2 Reqd  
 Ford; Bronco Full Size; 1990-1988; 6-Cyl. 4.9 Eng.; Tube Nut To Trans.; 2 Reqd  
 Ford; Bronco Full Size; 1990-1988; V-8 5.0 Eng.; Tube Nut To Trans.; 2 Reqd  
 Ford; Bronco Full Size; 1990-1988; V-8 5.8 Eng.; Tube Nut To Trans.; 2 Reqd  
 Ford; Country Squire; 1991-1988; V-8 5.0 Eng.; Tube Nut To Trans.; 2 Reqd  
 Ford; Crown Victoria; 1997-1996; V-8 4.6 Eng.; Tube Nut; W/O Aux. Cooler; 4 Reqd  
 Ford; Crown Victoria; 1995-1992; V-8 4.6 Eng.; Tube Nut To Trans.; 2 Reqd  
 Ford; E Van; 1996-1988; 6-Cyl. 4.9 Eng.; Tube Nut To Trans.; 2 Reqd  
 Ford; E Van; 1996-1988; V-8 5.0 Eng.; Tube Nut To Trans.; 2 Reqd  
 Ford; E Van; 1996-1988; V-8 5.8 Eng.; Tube Nut To Trans.; 2 Reqd  
 Ford; E Van; 1996-1988; V-8 7.3 Diesel Eng.; Tube Nut To Trans.; 2 Reqd  
 Ford; E Van; 1996-1988; V-8 7.5 Eng.; Tube Nut To Trans.; 2 Reqd  
 Ford; Escort; 1990-1988; 4-Cyl. 1.9 Eng.; Tube Nut To Trans.; Service Item; 2 Reqd  
 Ford; F Pickup; 1996-1990; 6-Cyl. 4.9 Eng.; Tube Nut To Trans.; 2 Reqd  
 Ford; F Pickup; 1996-1990; V-8 5.0 Eng.; Tube Nut To Trans.; 2 Reqd  
 Ford; F Pickup; 1996-1990; V-8 5.8 Eng.; Tube Nut To Trans.; 2 Reqd  
 Ford; F Pickup; 1996-1990; V-8 7.3 Diesel Eng.; Tube Nut To Trans.; 2 Reqd  
 Ford; F Pickup; 1996-1990; V-8 7.5 Eng.; Tube Nut To Trans.; 2 Reqd  
 Ford; Ltd Crown Victoria; 1991-1988; V-8 5.0 Eng.; Tube Nut To Trans.; 2 Reqd  
 Ford; Ltd Crown Victoria; 1991-1988; V-8 5.8 Eng.; Tube Nut To Trans.; 2 Reqd  
 Ford; Mustang; 1993-1988; 4-Cyl. 2.3 Eng.; Tube Nut To Trans.; W/5/16" Tubing; 2 Reqd  
 Ford; Mustang; 1996-1994; V-6 3.8 Eng.; Tube Nut To Trans.; 2 Reqd  
 Ford; Mustang; 1995-1994; V-8 5.0 Eng.; Tube Nut To Trans.; 2 Reqd  
 Ford; Mustang; 1993-1989; V-8 5.0 Eng.; Tube Nut To Trans.; W/5/16" Tubing; 2 Reqd  
 Ford; Mustang; 1995; V-8 5.8 Eng.; Tube Nut To Trans.; 2 Reqd  
 Ford; Taurus; 1991-1986; 4-Cyl. 2.5 Eng.; Tube Nut To Trans.; Service Item; 2 Reqd  
 Ford; Taurus; 1989-1986; V-6 3.0 Eng.; Tube Nut To Trans.; Service Item; 2 Reqd  
 Ford; Taurus; 1989-1988; V-6 3.8 Eng.; Tube Nut To Trans.; Service Item; 2 Reqd  
 Ford; Thunderbird; 1988; 4-Cyl. 2.3 Eng.; Tube Nut To Trans.; 2 Reqd  
 Ford; Thunderbird; 1997-1996; V-6 3.8 Eng.; Tube Nut To Trans.; 2 Reqd  
 Ford; Thunderbird; 1995-1990; V-6 3.8 Eng.; Tube Nut To Trans.; W/Schgr; 2 Reqd  
 Ford; Thunderbird; 1989-1988; V-6 3.8 Eng.; Tube Nut To Trans.; 2 Reqd  
 Ford; Thunderbird; 1997-1996; V-8 4.6 Eng.; Tube Nut To Trans.; 2 Reqd  
 Ford; Thunderbird; 1988; V-8 5.0 Eng.; Tube Nut To Trans.; 2 Reqd  
 GMC; C&K Pickup; 1986-1985; 6-Cyl. 4.8 Eng.; Tube Nut; 4 Reqd  
 GMC; C&K Pickup; 1995-1988; V-6 4.3 Eng.; Tube Nut; 4 Reqd  
 GMC; C&K Pickup; 1986-1985; V-6 4.3 Eng.; Tube Nut; 4 Reqd  
 GMC; C&K Pickup; 1995-1988; V-8 5.0 Eng.; Tube Nut; 4 Reqd  
 GMC; C&K Pickup; 1986-1985; V-8 5.0 Eng.; Tube Nut; 4 Reqd  
 GMC; C&K Pickup; 1995-1993; V-8 5.7 Eng.; Tube Nut; As Reqd  
 GMC; C&K Pickup; 1992-1988; V-8 5.7 Eng.; Tube Nut; 4 Reqd  
 GMC; C&K Pickup; 1986-1985; V-8 5.7 Eng.; Tube Nut; 4 Reqd  
 GMC; C&K Pickup; 1993-1988; V-8 6.2 Diesel Eng.; Tube Nut; 4 Reqd  
 GMC; C&K Pickup; 1986-1985; V-8 6.2 Diesel Eng.; Tube Nut; 4 Reqd  
 GMC; C&K Pickup; 1995-1993; V-8 6.5 Diesel Eng.; Tube Nut; As Reqd  
 GMC; C&K Pickup; 1992; V-8 6.5 Diesel Eng.; Tube Nut; 4 Reqd  
 GMC; C&K Pickup; 1995-1993; V-8 7.4 Eng.; Tube Nut; As Reqd  
 GMC; C&K Pickup; 1992-1988; V-8 7.4 Eng.; Tube Nut; 4 Reqd  
 GMC; C&K Pickup; 1986-1985; V-8 7.4 Eng.; Tube Nut; 4 Reqd  
 GMC; Caballero; 1987-1986; V-6 4.3 Eng.; Tube Nut; 4 Reqd  
 GMC; Caballero; 1987-1986; V-8 5.0 Eng.; Tube Nut; 4 Reqd  
 GMC; G Van; 1996-1986; V-6 4.3 Eng.; Tube Nut; As Reqd  
 GMC; G Van; 1995-1986; V-8 5.0 Eng.; Tube Nut; As Reqd  
 GMC; G Van; 1996-1986; V-8 5.7 Eng.; Tube Nut; As Reqd  
 GMC; G Van; 1993-1986; V-8 6.2 Diesel Eng.; Tube Nut; As Reqd  
 GMC; G Van; 1996-1994; V-8 6.5 Diesel Eng.; Tube Nut; As Reqd

# Numerical Listing - Oil Cooler Assemblies & End Fittings

## A63011 - Continued

GMC; G Van; 1996-1988; V-8 7.4 Eng.; Tube Nut; As Reqd  
 GMC; Jimmy; 1995-1992; V-6 4.3 Eng.; Tube Nut; 4 Reqd  
 GMC; Jimmy Compact; 1988-1987; 4-Cyl. 2.5 Eng.; Tube Nut; 4 Reqd  
 GMC; Jimmy Compact; 1989-1987; V-6 2.8 Eng.; Tube Nut; 4 Reqd  
 GMC; Jimmy Compact; 1991-1988; V-6 4.3 Eng.; Tube Nut; 4 Reqd  
 GMC; Jimmy Full Size; 1987; V-8 5.0 Eng.; Tube Nut; 4 Reqd  
 GMC; Jimmy Full Size; 1991-1987; V-8 5.7 Eng.; Tube Nut; 4 Reqd  
 GMC; Jimmy Full Size; 1991-1987; V-8 6.2 Diesel Eng.; Tube Nut; As Reqd  
 GMC; R&V Pickup; 1988-1987; 6-Cyl. 4.8 Eng.; Tube Nut; 4 Reqd  
 GMC; R&V Pickup; 1987; V-6 4.3 Eng.; Tube Nut; 4 Reqd  
 GMC; R&V Pickup; 1987; V-8 5.0 Eng.; Tube Nut; 4 Reqd  
 GMC; R&V Pickup; 1991-1987; V-8 5.7 Eng.; Tube Nut; 4 Reqd  
 GMC; R&V Pickup; 1991-1987; V-8 6.2 Diesel Eng.; Tube Nut; 4 Reqd  
 GMC; R&V Pickup; 1991-1987; V-8 7.4 Eng.; Tube Nut; 4 Reqd  
 GMC; S Pickup; 1990-1986; 4-Cyl. 2.5 Eng.; Tube Nut; 4 Reqd  
 GMC; S Pickup; 1990-1986; V-6 2.8 Eng.; Tube Nut; 4 Reqd  
 GMC; S Pickup; 1990-1988; V-6 4.3 Eng.; Tube Nut; 4 Reqd  
 GMC; Safari; 1990-1985; 4-Cyl. 2.5 Eng.; Tube Nut; 4 Reqd  
 GMC; Safari; 1994-1985; V-6 4.3 Eng.; Tube Nut; 4 Reqd  
 GMC; Sonoma; 1997-1994; 4-Cyl. 2.2 Eng.; Tube Nut; 4 Reqd  
 GMC; Sonoma; 1993-1991; 4-Cyl. 2.5 Eng.; Tube Nut; 4 Reqd  
 GMC; Sonoma; 1993-1991; V-6 2.8 Eng.; Tube Nut; 4 Reqd  
 GMC; Sonoma; 1995-1991; V-6 4.3 Eng.; Tube Nut; 4 Reqd  
 GMC; Suburban; 1987-1985; V-8 5.0 Eng.; Tube Nut; 4 Reqd  
 GMC; Suburban; 1995-1993; V-8 5.7 Eng.; Tube Nut; As Reqd  
 GMC; Suburban; 1992-1985; V-8 5.7 Eng.; Tube Nut; 4 Reqd  
 GMC; Suburban; 1991-1985; V-8 6.2 Diesel Eng.; Tube Nut; 4 Reqd  
 GMC; Suburban; 1995-1994; V-8 6.5 Diesel Eng.; Tube Nut; As Reqd  
 GMC; Suburban; 1995-1993; V-8 7.4 Eng.; Tube Nut; As Reqd  
 GMC; Suburban; 1992-1985; V-8 7.4 Eng.; Tube Nut; 4 Reqd  
 GMC; Syclone; 1992-1991; V-6 4.3 Eng.; Tube Nut; 4 Reqd  
 GMC; Typhoon; 1993-1992; V-6 4.3 Eng.; Tube Nut; 4 Reqd  
 GMC; Yukon; 1995-1993; V-8 5.7 Eng.; Tube Nut; As Reqd  
 GMC; Yukon; 1992; V-8 5.7 Eng.; Tube Nut; 4 Reqd  
 GMC; Yukon; 1995-1994; V-8 6.5 Diesel Eng.; Tube Nut; As Reqd  
 Linc; Continental; 1989-1988; V-6 3.8 Eng.; Tube Nut To Trans.; 2 Reqd  
 Linc; Mark VII; 1992-1988; V-8 5.0 Eng.; Tube Nut To Trans.; 2 Reqd  
 Linc; Mark VIII; 1998-1996; V-8 4.6 Eng.; Tube Nut; W/O Aux. Cooler; 4 Reqd  
 Linc; Mark VIII; 1995-1993; V-8 4.6 Eng.; Tube Nut To Trans.; 2 Reqd  
 Linc; Town Car; 1995-1991; V-8 4.6 Eng.; Tube Nut To Trans.; 2 Reqd  
 Linc; Town Car; 1990-1988; V-8 5.0 Eng.; Tube Nut To Trans.; 2 Reqd  
 Merc; Colony Park; 1991-1988; V-8 5.0 Eng.; Tube Nut To Trans.; 2 Reqd  
 Merc; Cougar; 1997-1996; V-6 3.8 Eng.; Tube Nut To Trans.; 2 Reqd  
 Merc; Cougar; 1990; V-6 3.8 Eng.; Tube Nut To Trans.; W/Schgr; 2 Reqd  
 Merc; Cougar; 1989-1988; V-6 3.8 Eng.; Tube Nut To Trans.; 2 Reqd  
 Merc; Cougar; 1997-1996; V-8 4.6 Eng.; Tube Nut To Trans.; 2 Reqd  
 Merc; Cougar; 1988; V-8 5.0 Eng.; Tube Nut To Trans.; 2 Reqd  
 Merc; Grand Marquis; 1995-1992; V-8 4.6 Eng.; Tube Nut To Trans.; 2 Reqd  
 Merc; Grand Marquis; 1991-1988; V-8 5.0 Eng.; Tube Nut To Trans.; 2 Reqd  
 Merc; Grand Marquis; 1989-1988; V-8 5.8 (Canada) Eng.; Tube Nut To Trans.; 2 Reqd  
 Merc; Sable; 1986; 4-Cyl. 2.5 Eng.; Tube Nut To Trans.; Service Item; 2 Reqd  
 Merc; Sable; 1989-1986; V-6 3.0 Eng.; Tube Nut To Trans.; Service Item; 2 Reqd  
 Merc; Sable; 1989-1988; V-6 3.8 Eng.; Tube Nut To Trans.; Service Item; 2 Reqd  
 Merc; Tracer; 1989-1988; 4-Cyl. 1.6 Eng.; Tube Nut To Trans.; Service Item; 2 Reqd  
 Olds; Bravada; 1994-1991; V-6 4.3 Eng.; Tube Nut; 4 Reqd  
 Olds; Custom Cruiser; 1992-1991; V-8 5.0 Eng.; Tube Nut From Rad; 2 Reqd  
 Olds; Custom Cruiser; 1992-1991; V-8 5.0 Eng.; Tube Nut To Trans. (Upper)  
 Olds; Custom Cruiser; 1990-1988; V-8 5.0 Eng.; Tube Nut; As Reqd  
 Olds; Cutlass Ciera; 1996-1993; 4-Cyl. 2.2 Eng.; Tube Nut; As Reqd  
 Olds; Cutlass Ciera; 1992-1988; 4-Cyl. 2.5 Eng.; Tube Nut; As Reqd  
 Olds; Cutlass Ciera; 1989-1988; V-6 2.8 Eng.; Tube Nut; As Reqd  
 Olds; Cutlass Ciera; 1996-1994; V-6 3.1 Eng.; Tube Nut; As Reqd  
 Olds; Cutlass Ciera; 1993-1989; V-6 3.3 Eng.; Tube Nut; As Reqd  
 Olds; Cutlass Ciera; 1988; V-6 3.8 Eng.; Tube Nut; As Reqd  
 Olds; Cutlass Cruiser; 1990; 4-Cyl. 2.5 Eng.; Tube Nut; As Reqd  
 Olds; Cutlass Cruiser; 1994; V-6 3.1 Eng.; Tube Nut; As Reqd  
 Olds; Cutlass Cruiser; 1993-1990; V-6 3.3 Eng.; Tube Nut; As Reqd  
 Olds; Cutlass Supreme; 1991-1990; 4-Cyl. 2.3 Eng.; Tube Nut; As Reqd  
 Olds; Delta 88; 1988-1986; V-6 3.8 Eng.; Tube Nut; As Reqd  
 Olds; Silhouette; 1994-1990; V-6 3.1 Eng.; Tube Nut; As Reqd  
 Olds; Toronado; 1990-1986; V-6 3.8 Eng.; Tube Nut; As Reqd

## A63011 - Continued

Pont; Firebird; 1989-1988; V-6 2.8 Eng.; Tube Nut; 4 Reqd  
 Pont; Firebird; 1992-1990; V-6 3.1 Eng.; Tube Nut; 4 Reqd  
 Pont; Firebird; 1995-1993; V-6 3.4 Eng.; Tube Nut; As Reqd  
 Pont; Firebird; 1997-1995; V-6 3.8 Eng.; Tube Nut; As Reqd  
 Pont; Firebird; 1992-1988; V-8 5.0 Eng.; Tube Nut; 4 Reqd  
 Pont; Firebird; 1997-1993; V-8 5.7 Eng.; Tube Nut; As Reqd  
 Pont; Firebird; 1992-1988; V-8 5.7 Eng.; Tube Nut; 4 Reqd  
 Pont; Grand Prix; 1991-1990; 4-Cyl. 2.3 Eng.; Tube Nut; As Reqd  
 Pont; Grand Prix; 1989-1988; V-6 2.8 Eng.; Tube Nut; As Reqd  
 Pont; Grand Prix; 1993-1991; V-6 3.1 Eng.; Tube Nut; W/3-Spd Trans.; 4 Reqd  
 Pont; Grand Prix; 1990-1989; V-6 3.1 Eng.; Tube Nut; As Reqd  
 Pont; Grand Prix; 1991; V-6 3.4 Eng.; Tube Nut; W/3-Spd Trans.; 4 Reqd  
 Pont; Trans Sport; 1995-1990; V-6 3.1 Eng.; Tube Nut; As Reqd  
 Pont; 6000; 1991-1985; 4-Cyl. 2.5 Eng.; Tube Nut; As Reqd  
 Pont; 6000; 1989-1985; V-6 2.8 Eng.; Tube Nut; As Reqd  
 Pont; 6000; 1991-1988; V-6 3.1 Eng.; Tube Nut; As Reqd

## A63013

Buick; Regal; 1993-1992; V-6 3.1 Eng.; Tube Nut; As Reqd  
 Buick; Regal; 1991; V-6 3.1 Eng.; Tube Nut; W/3/8" Tubing; As Reqd  
 Buick; Regal; 1993-1990; V-6 3.8 Eng.; Tube Nut; As Reqd  
 Buick; Regal; 1987-1986; V-6 3.8 Eng.; Tube Nut; 4 Reqd  
 Buick; Regal; 1987-1986; V-8 5.0 Eng.; Tube Nut; 4 Reqd  
 Buick; Roadmaster; 1996-1994; V-8 5.7 Eng.; Rad Supply Tube Nut (Upper); W/Aux. Cooler  
 Cad; Escalade; 2000-1999; V-8 5.7 Eng.; Tube Nut; Service Item; 2 Reqd  
 Cad; Fleetwood; 1993; V-8 5.7 Eng.; Tube Nut From Rad (Lower); 2 Reqd  
 Chev; C&K Pickup; 1997-1996; V-6 4.3 Eng.; Tube Nut; Service Item; 4 Reqd  
 Chev; C&K Pickup; 1997-1996; V-8 5.0 Eng.; Tube Nut; Service Item; 4 Reqd  
 Chev; C&K Pickup; 2000-1999; V-8 5.7 Eng.; Tube Nut; Service Item; 2 Reqd  
 Chev; C&K Pickup; 1998; V-8 5.7 Eng.; Tube Nut; Service Item; As Reqd  
 Chev; C&K Pickup; 1997-1996; V-8 5.7 Eng.; Tube Nut; Service Item; 2 Reqd  
 Chev; C&K Pickup; 2002-2001; V-8 6.5 Diesel Eng.; Tube Nut; Service Item; As Reqd  
 Chev; C&K Pickup; 2000-1996; V-8 6.5 Diesel Eng.; Tube Nut; Service Item; 2 Reqd  
 Chev; C&K Pickup; 2000-1997; V-8 7.4 Eng.; Tube Nut; Service Item; 2 Reqd  
 Chev; C&K Pickup; 1996; V-8 7.4 Eng.; Tube Nut; Service Item; As Reqd  
 Chev; C&K Pickup; 2002-2001; V-8 8.1 Eng.; Tube Nut; Service Item; 2 Reqd  
 Chev; Caprice; 1996-1994; V-8 4.3 Eng.; Rad Supply Tube Nut (Upper); W/Aux. Cooler  
 Chev; Caprice; 1996-1994; V-8 5.7 Eng.; Rad Supply Tube Nut (Upper); W/Aux. Cooler  
 Chev; Corvette; 2003-1997; V-8 5.7 Eng.; Tube Nut; 4 Reqd  
 Chev; Impala SS; 1996-1994; V-8 5.7 Eng.; Rad Supply Tube Nut (Upper); W/Aux. Cooler  
 Chev; Lumina; 1993-1991; V-6 3.1 Eng.; Tube Nut; W/4-Spd Trans.; 2 Reqd  
 Chev; Lumina; 1993; V-6 3.4 Eng.; Tube Nut; W/4-Spd Trans.; 2 Reqd  
 Chev; Silverado Pickup; 1999; V-8 6.5 Diesel Eng.; Tube Nut; Service Item; 2 Reqd  
 Chev; Suburban; 1999-1996; V-8 5.7 Eng.; Tube Nut; Service Item; 2 Reqd  
 Chev; Suburban; 1999-1996; V-8 6.5 Diesel Eng.; Tube Nut; Service Item; 2 Reqd  
 Chev; Suburban; 1999-1996; V-8 7.4 Eng.; Tube Nut; Service Item; 2 Reqd  
 Chev; Tahoe; 2000-1996; V-8 5.7 Eng.; Tube Nut; Service Item; 2 Reqd  
 Chev; Tahoe; 1999-1996; V-8 6.5 Diesel Eng.; Tube Nut; Service Item; 2 Reqd  
 Ford; Aerostar; 1997-1987; V-6 3.0 Eng.; Tube Nut To Trans.; 2 Reqd  
 Ford; Aerostar; 1997-1990; V-6 4.0 Eng.; Tube Nut To Trans.; 2 Reqd  
 Ford; Bronco Compact; 1990-1988; V-6 2.9 Eng.; Tube Nut To Trans.; 2 Reqd  
 Ford; Explorer; 1995-1991; V-6 4.0 Eng.; Tube Nut To Trans.; 2 Reqd  
 Ford; Ranger; 1988; 4-Cyl. 2.0 Eng.; Tube Nut To Trans.; 2 Reqd  
 Ford; Ranger; 1997-1988; 4-Cyl. 2.3 Eng.; Tube Nut To Trans.; 2 Reqd  
 Ford; Ranger; 1992-1988; V-6 2.9 Eng.; Tube Nut To Trans.; 2 Reqd  
 Ford; Ranger; 1997-1991; V-6 3.0 Eng.; Tube Nut To Trans.; 2 Reqd  
 Ford; Ranger; 1997-1990; V-6 4.0 Eng.; Tube Nut To Trans.; 2 Reqd  
 GMC; C&K Pickup; 1997-1996; V-6 4.3 Eng.; Tube Nut; Service Item; 4 Reqd  
 GMC; C&K Pickup; 1997-1996; V-8 5.0 Eng.; Tube Nut; Service Item; 4 Reqd

Product Section

Troubleshooting

EOC Applications

TOC Applications

Numerical Listing

Manufacturers' Part Numbers

End Fittings

Illustrations

# Numerical Listing - Oil Cooler Assemblies & End Fittings

Product Section

Troubleshooting

EOC Applications

TOC Applications

Numerical Listing

Manufacturers' Part Numbers

End Fittings

Illustrations

## A63013 - Continued

GMC; C&K Pickup; 2000-1996; V-8 5.7 Eng.; Tube Nut; Service Item; 2 Reqd  
 GMC; C&K Pickup; 2002-2001; V-8 6.5 Diesel Eng.; Tube Nut; Service Item; As Reqd  
 GMC; C&K Pickup; 2000-1996; V-8 6.5 Diesel Eng.; Tube Nut; Service Item; 2 Reqd  
 GMC; C&K Pickup; 2000-1996; V-8 7.4 Eng.; Tube Nut; Service Item; 2 Reqd  
 GMC; C&K Pickup; 2002-2001; V-8 8.1 Eng.; Tube Nut; Service Item; 2 Reqd  
 GMC; Sierra Pickup; 1999; V-8 6.5 Diesel Eng.; Tube Nut; Service Item; 2 Reqd  
 GMC; Suburban; 1999-1996; V-8 5.7 Eng.; Tube Nut; Service Item; 2 Reqd  
 GMC; Suburban; 1999-1996; V-8 6.5 Diesel Eng.; Tube Nut; Service Item; 2 Reqd  
 GMC; Suburban; 1999-1996; V-8 7.4 Eng.; Tube Nut; Service Item; 2 Reqd  
 GMC; Yukon; 2000-1996; V-8 5.7 Eng.; Tube Nut; Service Item; 2 Reqd  
 GMC; Yukon; 1997-1996; V-8 6.5 Diesel Eng.; Tube Nut; Service Item; 2 Reqd  
 Olds; Aurora; 2003-2001; V-8 4.0 Eng.; Tube Nut To Trans. (Upper)  
 Olds; Aurora; 1999-1995; V-8 4.0 Eng.; Tube Nut To Trans. (Upper)  
 Olds; Cutlass Supreme; 1989-1988; V-6 2.8 Eng.; Tube Nut; As Reqd  
 Olds; Cutlass Supreme; 1993-1991; V-6 3.1 Eng.; Tube Nut; W/3-Spd Trans.; As Reqd  
 Olds; Cutlass Supreme; 1990-1989; V-6 3.1 Eng.; Tube Nut; As Reqd  
 Olds; Cutlass Supreme; 1993-1991; V-6 3.4 Eng.; Tube Nut; W/3-Spd Trans.; As Reqd  
 Olds; Cutlass Supreme; 1988; V-8 5.0 Eng.; Tube Nut; As Reqd  
 Olds; Eighty Eight; 1993; V-6 3.8 Eng.; Tube Nut; As Reqd  
 Olds; Ninety Eight; 1995-1993; V-6 3.8 Eng.; Tube Nut; As Reqd  
 Pont; Grand Prix; 1993-1991; V-6 3.1 Eng.; Tube Nut; W/4-Spd Trans.; 2 Reqd  
 Pont; Grand Prix; 1993-1992; V-6 3.4 Eng.; Tube Nut; 2 Reqd  
 Pont; Grand Prix; 1991; V-6 3.4 Eng.; Tube Nut; W/4-Spd Trans.; 2 Reqd  
 Pont; Trans Sport; 1995-1992; V-6 3.8 Eng.; Tube Nut; 2 Reqd

## A63017

Chev; Blazer Full Size; 1994-1993; V-8 5.7 Eng.; Connector From Aux. Cooler; 2 Reqd  
 Chev; Blazer Full Size; 1991-1987; V-8 6.2 Diesel Eng.; Connector From Aux. Cooler; 2 Reqd  
 Chev; Blazer Full Size; 1994; V-8 6.5 Diesel Eng.; Connector From Aux. Cooler; 2 Reqd  
 Chev; C&K Pickup; 1995-1993; V-8 5.7 Eng.; Connector From Aux. Cooler; 2 Reqd  
 Chev; C&K Pickup; 1995-1993; V-8 6.5 Diesel Eng.; Connector From Aux. Cooler; 2 Reqd  
 Chev; C&K Pickup; 1995-1993; V-8 7.4 Eng.; Connector From Aux. Cooler; 2 Reqd  
 Chev; Express; 2003; V-8 4.8 Eng.; Connector From Aux. Cooler; W/16-Bolt Trans. Pan (M30); 2 Reqd  
 Chev; Suburban; 1995-1993; V-8 5.7 Eng.; Connector From Aux. Cooler; 2 Reqd  
 Chev; Suburban; 1995-1994; V-8 6.5 Diesel Eng.; Connector From Aux. Cooler; 2 Reqd  
 Chev; Suburban; 1995-1993; V-8 7.4 Eng.; Connector From Aux. Cooler; 2 Reqd  
 Chev; Tahoe; 1995; V-8 5.7 Eng.; Connector From Aux. Cooler; 2 Reqd  
 Chev; Tahoe; 1995; V-8 6.5 Diesel Eng.; Connector From Aux. Cooler; 2 Reqd  
 GMC; C&K Pickup; 1995-1993; V-8 5.7 Eng.; Connector From Aux. Cooler; 2 Reqd  
 GMC; C&K Pickup; 1995-1993; V-8 6.5 Diesel Eng.; Connector From Aux. Cooler; 2 Reqd  
 GMC; C&K Pickup; 1995-1993; V-8 7.4 Eng.; Connector From Aux. Cooler; 2 Reqd  
 GMC; Jimmy Full Size; 1991-1987; V-8 6.2 Diesel Eng.; Connector From Aux. Cooler; 2 Reqd  
 GMC; Savana; 2003; V-8 4.8 Eng.; Connector From Aux. Cooler; W/16-Bolt Trans. Pan (M30); 2 Reqd  
 GMC; Suburban; 1995-1993; V-8 5.7 Eng.; Connector From Aux. Cooler; 2 Reqd  
 GMC; Suburban; 1995-1994; V-8 6.5 Diesel Eng.; Connector From Aux. Cooler; 2 Reqd  
 GMC; Suburban; 1995-1993; V-8 7.4 Eng.; Connector From Aux. Cooler; 2 Reqd  
 GMC; Yukon; 1995-1993; V-8 5.7 Eng.; Connector From Aux. Cooler; 2 Reqd  
 GMC; Yukon; 1995-1994; V-8 6.5 Diesel Eng.; Connector From Aux. Cooler; 2 Reqd

## A63018

Buick; Century; 1999-1998; V-6 3.1 Eng.; Connector From Rad; 2 Reqd  
 Buick; Lesabre; 2005-2000; V-6 3.8 Eng.; Connector From Rad; 2 Reqd  
 Buick; Park Ave.; 2005-2000; V-6 3.8 Eng.; Connector From Rad; 2 Reqd  
 Buick; Rainier; 2004; V-8 5.3 Eng.; Connector From Rad; W/O Aux. Cooler; As Reqd  
 Buick; Regal; 1999-1998; V-6 3.8 Eng.; Connector From Rad; 2 Reqd  
 Cad; Deville; 2000; V-8 4.6 Eng.; Connector From Rad (Upper)  
 Cad; Escalade; 2004-2002; V-8 5.3 Eng.; Connector From Rad; W/O Aux. Cooler; As Reqd  
 Cad; Escalade; 2004-2002; V-8 6.0 Eng.; Connector From Rad; W/O Aux. Cooler; As Reqd  
 Cad; Seville; 2000; V-8 4.6 Eng.; Connector From Rad (Upper)  
 Chev; Astro; 2005-1996; V-6 4.3 Eng.; Connector From Rad; 2 Reqd  
 Chev; Avalanche; 2003-2002; V-8 5.3 Eng.; Connector From Rad; W/O Aux. Cooler; As Reqd  
 Chev; Blazer; 2004-1996; V-6 4.3 Eng.; Connector From Rad; 2 Reqd  
 Chev; Express; 2002-1996; V-6 4.3 Eng.; Connector From Rad; W/16-Bolt Trans. Pan (M30); 2 Reqd  
 Chev; Express; 2002-1996; V-8 5.0 Eng.; Connector From Rad; 2 Reqd  
 Chev; Express; 2002-1996; V-8 5.7 Eng.; Connector From Rad; W/16-Bolt Trans. Pan (M30); 2 Reqd  
 Chev; Express; 1996; V-8 6.5 Diesel Eng.; Connector From Rad; W/Quick Connect Fitting; 2 Reqd  
 Chev; Express; 1996; V-8 7.4 Eng.; Connector From Rad; W/Aux. Cooler; 2 Reqd  
 Chev; Express; 1996; V-8 7.4 Eng.; Inlet Fitting To Trans. (Upper); W/Aux. Cooler  
 Chev; Express; 1996; V-8 7.4 Eng.; Outlet Fitting To Trans. (Lower); W/Aux. Cooler  
 Chev; G Van; 1998-1997; V-6 4.3 Eng.; Connector From Rad; W/16-Bolt Trans. Pan (M30); 2 Reqd  
 Chev; G Van; 1998-1997; V-8 5.0 Eng.; Connector From Rad; 2 Reqd  
 Chev; G Van; 1998-1997; V-8 5.7 Eng.; Connector From Rad; W/16-Bolt Trans. Pan (M30); 2 Reqd  
 Chev; Lumina; 1999-1998; V-6 3.1 Eng.; Connector From Rad; W/Aux. Cooler; 2 Reqd  
 Chev; Lumina; 1999-1998; V-6 3.8 Eng.; Connector From Rad; W/Aux. Cooler; 2 Reqd  
 Chev; Monte Carlo; 1999-1998; V-6 3.1 Eng.; Connector From Rad; W/Aux. Cooler; 2 Reqd  
 Chev; Monte Carlo; 1999-1998; V-6 3.8 Eng.; Connector From Rad; W/Aux. Cooler; 2 Reqd  
 Chev; S Pickup; 2003-1998; 4-Cyl. 2.2 Eng.; Connector From Rad; 2 Reqd  
 Chev; S Pickup; 2001-1996; V-6 4.3 Eng.; Connector From Rad; 2 Reqd  
 Chev; Silverado Pickup; 2003-1999; V-6 4.3 Eng.; Connector From Rad; W/O Aux. Cooler; As Reqd  
 Chev; Silverado Pickup; 2003-1999; V-8 4.8 Eng.; Connector From Rad; W/O Aux. Cooler; As Reqd  
 Chev; Silverado Pickup; 2003-1999; V-8 5.3 Eng.; Connector From Rad; W/O Aux. Cooler; As Reqd  
 Chev; Silverado Pickup; 2003-1999; V-8 6.0 Eng.; Connector From Rad; 2 Reqd  
 Chev; Suburban; 2003-2000; V-8 5.3 Eng.; Connector From Rad; W/O Aux. Cooler; As Reqd  
 Chev; Suburban; 2003-2000; V-8 6.0 Eng.; Connector From Rad; 2 Reqd  
 Chev; Tahoe; 2003-2000; V-8 4.8 Eng.; Connector From Rad; W/O Aux. Cooler; As Reqd  
 Chev; Tahoe; 2003-2000; V-8 5.3 Eng.; Connector From Rad; W/O Aux. Cooler; As Reqd  
 Chev; Trailblazer; 2004-2003; V-8 5.3 Eng.; Connector From Rad; W/O Aux. Cooler; As Reqd  
 GMC; Envoy; 2004-2003; V-8 5.3 Eng.; Connector From Rad; W/O Aux. Cooler; As Reqd  
 GMC; Jimmy; 2001-1996; V-6 4.3 Eng.; Connector From Rad; 2 Reqd  
 GMC; Jimmy; 2004-2002; V-6 4.3 (Canada) Eng.; Connector From Rad; 2 Reqd  
 GMC; Safari; 2005-1996; V-6 4.3 Eng.; Connector From Rad; 2 Reqd  
 GMC; Savana; 2002-1996; V-6 4.3 Eng.; Connector From Rad; W/16-Bolt Trans. Pan (M30); 2 Reqd  
 GMC; Savana; 2002-1996; V-8 5.0 Eng.; Connector From Rad; 2 Reqd  
 GMC; Savana; 2002-1996; V-8 5.7 Eng.; Connector From Rad; W/16-Bolt Trans. Pan (M30); 2 Reqd  
 GMC; Savana; 1996; V-8 6.5 Diesel Eng.; Connector From Rad; W/Quick Connect Fitting; 2 Reqd  
 GMC; Savana; 1996; V-8 7.4 Eng.; Connector From Rad; W/Aux. Cooler; 2 Reqd  
 GMC; Savana; 1996; V-8 7.4 Eng.; Inlet Fitting To Trans. (Upper); W/Aux. Cooler  
 GMC; Savana; 1996; V-8 7.4 Eng.; Outlet Fitting To Trans. (Lower); W/Aux. Cooler  
 GMC; Sierra Pickup; 2003-1999; V-6 4.3 Eng.; Connector From Rad; W/O Aux. Cooler; As Reqd



# Numerical Listing - Oil Cooler Assemblies & End Fittings

## A63018 - Continued

GMC; Sierra Pickup; 2003-1999; V-8 4.8 Eng.; Connector From Rad; W/O Aux. Cooler; As Reqd  
 GMC; Sierra Pickup; 2003-1999; V-8 5.3 Eng.; Connector From Rad; W/O Aux. Cooler; As Reqd  
 GMC; Sierra Pickup; 2003-1999; V-8 6.0 Eng.; Connector From Rad; 2 Reqd  
 GMC; Sonoma; 2003-1998; 4-Cyl. 2.2 Eng.; Connector From Rad; 2 Reqd  
 GMC; Sonoma; 2001-1996; V-6 4.3 Eng.; Connector From Rad; 2 Reqd  
 GMC; Yukon; 2003-2000; V-8 4.8 Eng.; Connector From Rad; W/O Aux. Cooler; As Reqd  
 GMC; Yukon; 2003-2000; V-8 5.3 Eng.; Connector From Rad; W/O Aux. Cooler; As Reqd  
 GMC; Yukon; 2003; V-8 6.0 Eng.; Connector From Rad; W/O Aux. Cooler; 2 Reqd  
 GMC; Yukon; 2002-2001; V-8 6.0 Eng.; Connector From Rad; As Reqd  
 GMC; Yukon; 2000; V-8 6.0 Eng.; Connector From Rad; 2 Reqd  
 Olds; Bravada; 2001-1996; V-6 4.3 Eng.; Connector From Rad; 2 Reqd  
 Olds; Intrigue; 2002-1999; V-6 3.5 Eng.; Connector From Rad; 2 Reqd  
 Olds; Intrigue; 1999-1998; V-6 3.8 Eng.; Connector From Rad; 2 Reqd  
 Pont; Bonneville; 2005-2000; V-6 3.8 Eng.; Connector From Rad; 2 Reqd  
 Pont; Grand Prix; 1999-1998; V-6 3.1 Eng.; Connector From Rad; W/Aux. Cooler; 2 Reqd  
 Pont; Grand Prix; 1999-1998; V-6 3.8 Eng.; Connector From Rad; W/Aux. Cooler; 2 Reqd

## A63019

Buick; Rainier; 2004; V-8 5.3 Eng.; Connector From Rad; W/Aux. Cooler; As Reqd  
 Cad; Escalade; 2004-2002; V-8 5.3 Eng.; Connector From Rad; W/Aux. Cooler; As Reqd  
 Cad; Escalade; 2000-1999; V-8 5.7 Eng.; Connector From Aux. Cooler; 2 Reqd  
 Cad; Escalade; 2004-2002; V-8 6.0 Eng.; Connector From Rad; W/Aux. Cooler; As Reqd  
 Chev; Avalanche; 2003-2002; V-8 5.3 Eng.; Connector From Rad; W/Aux. Cooler; As Reqd  
 Chev; Avalanche; 2003-2002; V-8 8.1 Eng.; Connector From Aux. Cooler; 2 Reqd  
 Chev; C&K Pickup; 2000-1996; V-8 5.7 Eng.; Connector From Aux. Cooler; 2 Reqd  
 Chev; C&K Pickup; 2002-1996; V-8 6.5 Diesel Eng.; Connector From Aux. Cooler; 2 Reqd  
 Chev; C&K Pickup; 2000-1996; V-8 7.4 Eng.; Connector From Aux. Cooler; 2 Reqd  
 Chev; C&K Pickup; 2002-2001; V-8 8.1 Eng.; Connector From Aux. Cooler; 2 Reqd  
 Chev; Silverado Pickup; 2003-1999; V-6 4.3 Eng.; Connector From Rad; W/Aux. Cooler; As Reqd  
 Chev; Silverado Pickup; 2003-1999; V-8 4.8 Eng.; Connector From Rad; W/Aux. Cooler; As Reqd  
 Chev; Silverado Pickup; 2003-1999; V-8 5.3 Eng.; Connector From Rad; W/Aux. Cooler; As Reqd  
 Chev; Silverado Pickup; 2003-1999; V-8 6.0 Eng.; Connector From Aux. Cooler; 2 Reqd  
 Chev; Silverado Pickup; 1999; V-8 6.5 Diesel Eng.; Connector From Aux. Cooler; 2 Reqd  
 Chev; Silverado Pickup; 2003-2001; V-8 8.1 Eng.; Connector From Aux. Cooler; 2 Reqd  
 Chev; Suburban; 2003-2000; V-8 5.3 Eng.; Connector From Rad; W/Aux. Cooler; As Reqd  
 Chev; Suburban; 1999-1996; V-8 5.7 Eng.; Connector From Aux. Cooler; 2 Reqd  
 Chev; Suburban; 2003-2000; V-8 6.0 Eng.; Connector From Aux. Cooler; 2 Reqd  
 Chev; Suburban; 1999-1996; V-8 6.5 Diesel Eng.; Connector From Aux. Cooler; 2 Reqd  
 Chev; Suburban; 1999-1996; V-8 7.4 Eng.; Connector From Aux. Cooler; 2 Reqd  
 Chev; Suburban; 2003-2001; V-8 8.1 Eng.; Connector From Aux. Cooler; 2 Reqd  
 Chev; Suburban; 2003; V-8 8.1 Eng.; Connector From Rad; 2 Reqd  
 Chev; Tahoe; 2003-2000; V-8 4.8 Eng.; Connector From Rad; W/Aux. Cooler; As Reqd  
 Chev; Tahoe; 2003-2000; V-8 5.3 Eng.; Connector From Rad; W/Aux. Cooler; As Reqd  
 Chev; Tahoe; 2000-1996; V-8 5.7 Eng.; Connector From Aux. Cooler; 2 Reqd  
 Chev; Tahoe; 1999-1996; V-8 6.5 Diesel Eng.; Connector From Aux. Cooler; 2 Reqd  
 Chev; Trailblazer; 2004-2003; V-8 5.3 Eng.; Connector From Rad; W/Aux. Cooler; As Reqd  
 GMC; C&K Pickup; 2000-1996; V-8 5.7 Eng.; Connector From Aux. Cooler; 2 Reqd

## A63019 - Continued

GMC; C&K Pickup; 2002-1996; V-8 6.5 Diesel Eng.; Connector From Aux. Cooler; 2 Reqd  
 GMC; C&K Pickup; 2000-1996; V-8 7.4 Eng.; Connector From Aux. Cooler; 2 Reqd  
 GMC; C&K Pickup; 2002-2001; V-8 8.1 Eng.; Connector From Aux. Cooler; 2 Reqd  
 GMC; Envoy; 2004-2003; V-8 5.3 Eng.; Connector From Rad; W/Aux. Cooler; As Reqd  
 GMC; Sierra Pickup; 2003-1999; V-6 4.3 Eng.; Connector From Rad; W/Aux. Cooler; As Reqd  
 GMC; Sierra Pickup; 2003-1999; V-8 4.8 Eng.; Connector From Rad; W/Aux. Cooler; As Reqd  
 GMC; Sierra Pickup; 2003-1999; V-8 5.3 Eng.; Connector From Rad; W/Aux. Cooler; As Reqd  
 GMC; Sierra Pickup; 2003-1999; V-8 6.0 Eng.; Connector From Aux. Cooler; 2 Reqd  
 GMC; Sierra Pickup; 1999; V-8 6.5 Diesel Eng.; Connector From Aux. Cooler; 2 Reqd  
 GMC; Sierra Pickup; 2003-2001; V-8 8.1 Eng.; Connector From Aux. Cooler; 2 Reqd  
 GMC; Suburban; 1999-1996; V-8 5.7 Eng.; Connector From Aux. Cooler; 2 Reqd  
 GMC; Suburban; 1999-1996; V-8 6.5 Diesel Eng.; Connector From Aux. Cooler; 2 Reqd  
 GMC; Suburban; 1999-1996; V-8 7.4 Eng.; Connector From Aux. Cooler; 2 Reqd  
 GMC; Yukon; 2003-2000; V-8 4.8 Eng.; Connector From Rad; W/Aux. Cooler; As Reqd  
 GMC; Yukon; 2003-2000; V-8 5.3 Eng.; Connector From Rad; W/Aux. Cooler; As Reqd  
 GMC; Yukon; 2000-1996; V-8 5.7 Eng.; Connector From Aux. Cooler; 2 Reqd  
 GMC; Yukon; 2003-2000; V-8 6.0 Eng.; Connector From Aux. Cooler; 2 Reqd  
 GMC; Yukon; 2003; V-8 6.0 Eng.; Connector From Rad; W/Aux. Cooler; As Reqd  
 GMC; Yukon; 1997-1996; V-8 6.5 Diesel Eng.; Connector From Aux. Cooler; 2 Reqd  
 GMC; Yukon; 2003-2001; V-8 8.1 Eng.; Connector From Aux. Cooler; 2 Reqd  
 GMC; Yukon; 2003; V-8 8.1 Eng.; Connector From Rad; 2 Reqd

## A63021

Buick; Century; 2003-2000; V-6 3.1 Eng.; Inlet Fitting To Trans. (Upper)  
 Buick; Lesabre; 2003-2000; V-6 3.8 Eng.; Inlet Fitting To Trans. (Upper)  
 Buick; Park Ave.; 2004; V-6 3.8 Eng.; Outlet Fitting To Trans. (Lower)  
 Buick; Park Ave.; 2003-2000; V-6 3.8 Eng.; Inlet Fitting To Trans. (Upper)  
 Buick; Rainier; 2004; 6-Cyl. 4.2 Eng.; Inlet Fitting To Trans. (Lower)  
 Buick; Rainier; 2004; 6-Cyl. 4.2 Eng.; Outlet Fitting To Trans. (Upper)  
 Buick; Rainier; 2004; V-8 5.3 Eng.; Inlet Fitting To Trans. (Upper)  
 Buick; Regal; 2003-2000; V-6 3.8 Eng.; Inlet Fitting To Trans. (Upper)  
 Buick; Rendezvous; 2003-2002; V-6 3.4 Eng.; Inlet Fitting To Trans. (Upper)  
 Cad; Escalade; 2004-2002; V-8 5.3 Eng.; Inlet Fitting To Trans. (Upper)  
 Cad; Escalade; 2000-1999; V-8 5.7 Eng.; Quick Connect Tube Fitting (Lower)  
 Cad; Escalade; 2000-1999; V-8 5.7 Eng.; Quick Connect Tube Fitting (Upper)  
 Cad; Escalade; 2004-2002; V-8 6.0 Eng.; Inlet Fitting To Trans. (Upper)  
 Chev; Astro; 2005-1996; V-6 4.3 Eng.; Inlet Fitting To Trans. (Upper)  
 Chev; Astro; 2005-1996; V-6 4.3 Eng.; Outlet Fitting To Trans. (Lower)  
 Chev; Avalanche; 2003-2002; V-8 5.3 Eng.; Inlet Fitting To Trans. (Upper)  
 Chev; Avalanche; 2003-2002; V-8 8.1 Eng.; Inlet Fitting To Trans. (Upper)  
 Chev; Avalanche; 2003-2002; V-8 8.1 Eng.; Outlet Fitting To Trans. (Lower)  
 Chev; Blazer; 2004-1996; V-6 4.3 Eng.; Inlet Fitting To Trans. (Lower)  
 Chev; Blazer; 2004-1996; V-6 4.3 Eng.; Outlet Fitting To Trans. (Upper)  
 Chev; C&K Pickup; 1998; V-6 4.3 Eng.; Quick Connect Tube Fitting (Lower)  
 Chev; C&K Pickup; 1998; V-6 4.3 Eng.; Quick Connect Tube Fitting (Upper)  
 Chev; C&K Pickup; 1997; V-6 4.3 Eng.; Quick Connect Tube Fitting (Lower); W/Fact Fitting  
 Chev; C&K Pickup; 1997; V-6 4.3 Eng.; Quick Connect Tube Fitting (Upper); W/Fact Fitting  
 Chev; C&K Pickup; 1996; V-6 4.3 Eng.; Quick Connect Tube Fitting; W/Fact Fitting; 2 Reqd  
 Chev; C&K Pickup; 1999-1998; V-8 5.0 Eng.; Quick Connect Tube Fitting (Lower)  
 Chev; C&K Pickup; 1999-1998; V-8 5.0 Eng.; Quick Connect Tube Fitting (Upper)  
 Chev; C&K Pickup; 1997; V-8 5.0 Eng.; Quick Connect Tube Fitting (Lower); W/Fact Fitting

## Numerical Listing - Oil Cooler Assemblies & End Fittings

### A63021 - Continued

Chev; C&K Pickup; 1997; V-8 5.0 Eng.; Quick Connect Tube Fitting (Upper); W/Fact Fitting  
 Chev; C&K Pickup; 1996; V-8 5.0 Eng.; Quick Connect Tube Fitting; W/Fact Fitting; 2 Reqd  
 Chev; C&K Pickup; 2000-1996; V-8 5.7 Eng.; Quick Connect Tube Fitting (Lower)  
 Chev; C&K Pickup; 2000-1996; V-8 5.7 Eng.; Quick Connect Tube Fitting (Upper)  
 Chev; C&K Pickup; 2002-1996; V-8 6.5 Diesel Eng.; Quick Connect Tube Fitting (Lower)  
 Chev; C&K Pickup; 2002-1996; V-8 6.5 Diesel Eng.; Quick Connect Tube Fitting (Upper)  
 Chev; C&K Pickup; 2000-1996; V-8 7.4 Eng.; Quick Connect Tube Fitting (Lower)  
 Chev; C&K Pickup; 2000-1997; V-8 7.4 Eng.; Quick Connect Tube Fitting (Upper); W/Fact Fitting  
 Chev; C&K Pickup; 1996; V-8 7.4 Eng.; Quick Connect Tube Fitting (Upper)  
 Chev; C&K Pickup; 2002-2001; V-8 8.1 Eng.; Quick Connect Tube Fitting (Lower)  
 Chev; C&K Pickup; 2002-2001; V-8 8.1 Eng.; Quick Connect Tube Fitting (Upper)  
 Chev; Camaro; 2002-1998; V-6 3.8 Eng.; Inlet Fitting To Trans. (Upper)  
 Chev; Camaro; 2002-1998; V-6 3.8 Eng.; Outlet Fitting To Trans. (Lower)  
 Chev; Camaro; 2002-1998; V-8 5.7 Eng.; Inlet Fitting To Trans. (Upper)  
 Chev; Camaro; 2002-1998; V-8 5.7 Eng.; Outlet Fitting To Trans. (Lower)  
 Chev; Express; 2003; V-6 4.3 Eng.; Connector From Rad; W/16-Bolt Trans. Pan (M30); 2 Reqd  
 Chev; Express; 2003; V-6 4.3 Eng.; Quick Connect Tube Fitting (Lower); W/16-Bolt Trans. Pan (M30)  
 Chev; Express; 2003; V-6 4.3 Eng.; Quick Connect Tube Fitting (Upper); W/16-Bolt Trans. Pan (M30)  
 Chev; Express; 2002-1996; V-6 4.3 Eng.; Inlet Fitting To Trans. (Upper); W/16-Bolt Trans. Pan (M30)  
 Chev; Express; 2002-1996; V-6 4.3 Eng.; Outlet Fitting To Trans. (Lower); W/16-Bolt Trans. Pan (M30)  
 Chev; Express; 2003; V-8 4.8 Eng.; Quick Connect Tube Fitting (Lower); W/O Aux. Cooler; 2 Reqd  
 Chev; Express; 2003; V-8 4.8 Eng.; Quick Connect Tube Fitting (Upper); W/O Aux. Cooler; 2 Reqd  
 Chev; Express; 2002-1996; V-8 5.0 Eng.; Inlet Fitting To Trans. (Upper)  
 Chev; Express; 2002-1996; V-8 5.0 Eng.; Outlet Fitting To Trans. (Lower)  
 Chev; Express; 2003; V-8 5.3 Eng.; Inlet Fitting To Trans. (Upper)  
 Chev; Express; 2003; V-8 5.3 Eng.; Outlet Fitting To Trans. (Lower)  
 Chev; Express; 2002-1996; V-8 5.7 Eng.; Inlet Fitting To Trans. (Upper); W/16-Bolt Trans. Pan (M30)  
 Chev; Express; 2002-2001; V-8 5.7 Eng.; Outlet Fitting To Trans. (Lower)  
 Chev; Express; 2000-1996; V-8 5.7 Eng.; Outlet Fitting To Trans. (Lower); W/16-Bolt Trans. Pan (M30)  
 Chev; Express; 1997; V-8 5.7 Eng.; Inlet Fitting To Trans. (Upper); W/17-Bolt Trans. Pan (MT1)  
 Chev; Express; 2002-1997; V-8 6.5 Diesel Eng.; Inlet Fitting To Trans. (Upper)  
 Chev; Express; 2002-1997; V-8 6.5 Diesel Eng.; Outlet Fitting To Trans. (Lower)  
 Chev; Express; 2000-1997; V-8 7.4 Eng.; Inlet Fitting To Trans. (Upper)  
 Chev; Express; 2000-1997; V-8 7.4 Eng.; Outlet Fitting To Trans. (Lower)  
 Chev; Express; 2002-2001; V-8 8.1 Eng.; Inlet Fitting To Trans. (Upper)  
 Chev; Express; 2002-2001; V-8 8.1 Eng.; Outlet Fitting To Trans. (Lower)  
 Chev; G Van; 1998-1997; V-6 4.3 Eng.; Inlet Fitting To Trans. (Upper); W/16-Bolt Trans. Pan (M30)  
 Chev; G Van; 1998-1997; V-6 4.3 Eng.; Outlet Fitting To Trans. (Lower); W/16-Bolt Trans. Pan (M30)  
 Chev; G Van; 1998-1997; V-8 5.0 Eng.; Inlet Fitting To Trans. (Upper)  
 Chev; G Van; 1998-1997; V-8 5.0 Eng.; Outlet Fitting To Trans. (Lower)  
 Chev; G Van; 1998-1997; V-8 5.7 Eng.; Inlet Fitting To Trans. (Upper); W/16-Bolt Trans. Pan (M30)  
 Chev; G Van; 1998-1997; V-8 5.7 Eng.; Outlet Fitting To Trans. (Lower); W/16-Bolt Trans. Pan (M30)  
 Chev; G Van; 1998-1997; V-8 6.5 Diesel Eng.; Inlet Fitting To Trans. (Upper)  
 Chev; G Van; 1998-1997; V-8 6.5 Diesel Eng.; Outlet Fitting To Trans. (Lower)  
 Chev; G Van; 1998-1997; V-8 7.4 Eng.; Inlet Fitting To Trans. (Upper)  
 Chev; G Van; 1998-1997; V-8 7.4 Eng.; Outlet Fitting To Trans. (Lower)  
 Chev; Impala; 2003-2000; V-6 3.4 Eng.; Inlet Fitting To Trans. (Upper)  
 Chev; Impala; 2003-2000; V-6 3.8 Eng.; Inlet Fitting To Trans. (Upper)  
 Chev; Lumina; 2001-2000; V-6 3.1 Eng.; Inlet Fitting To Trans. (Upper)  
 Chev; Monte Carlo; 2003-2000; V-6 3.4 Eng.; Inlet Fitting To Trans. (Upper)  
 Chev; Monte Carlo; 2003-2000; V-6 3.8 Eng.; Inlet Fitting To Trans. (Upper)  
 Chev; S Pickup; 2003-1998; 4-Cyl. 2.2 Eng.; Inlet Fitting To Trans. (Lower)

### A63021 - Continued

Chev; S Pickup; 2003-1998; 4-Cyl. 2.2 Eng.; Outlet Fitting To Trans. (Upper)  
 Chev; S Pickup; 2004-1996; V-6 4.3 Eng.; Inlet Fitting To Trans. (Lower)  
 Chev; S Pickup; 2004-1996; V-6 4.3 Eng.; Outlet Fitting To Trans. (Upper)  
 Chev; Silverado Pickup; 2003-1999; V-6 4.3 Eng.; Inlet Fitting To Trans. (Upper)  
 Chev; Silverado Pickup; 2003-1999; V-8 4.8 Eng.; Inlet Fitting To Trans. (Upper)  
 Chev; Silverado Pickup; 2003-1999; V-8 5.3 Eng.; Inlet Fitting To Trans. (Upper)  
 Chev; Silverado Pickup; 2003; V-8 6.0 Eng.; Quick Connect Tube Fitting (Lower)  
 Chev; Silverado Pickup; 2003-2002; V-8 6.0 Eng.; Quick Connect Tube Fitting (Upper)  
 Chev; Silverado Pickup; 2002-2001; V-8 6.0 Eng.; Quick Connect Tube Fitting (Lower); W/17-Bolt Trans. Pan (MT1)  
 Chev; Silverado Pickup; 2001; V-8 6.0 Eng.; Quick Connect Tube Fitting (Lower); W/16-Bolt Trans. Pan (M30)  
 Chev; Silverado Pickup; 2001; V-8 6.0 Eng.; Quick Connect Tube Fitting (Upper); W/16-Bolt Trans. Pan (M30)  
 Chev; Silverado Pickup; 2001; V-8 6.0 Eng.; Quick Connect Tube Fitting (Upper); W/17-Bolt Trans. Pan (MT1)  
 Chev; Silverado Pickup; 2000-1999; V-8 6.0 Eng.; Quick Connect Tube Fitting (Lower)  
 Chev; Silverado Pickup; 2000-1999; V-8 6.0 Eng.; Quick Connect Tube Fitting (Upper)  
 Chev; Silverado Pickup; 1999; V-8 6.5 Diesel Eng.; Quick Connect Tube Fitting (Lower)  
 Chev; Silverado Pickup; 1999; V-8 6.5 Diesel Eng.; Quick Connect Tube Fitting (Upper)  
 Chev; Silverado Pickup; 2003-2001; V-8 8.1 Eng.; Inlet Fitting To Trans. (Upper)  
 Chev; Silverado Pickup; 2003-2001; V-8 8.1 Eng.; Outlet Fitting To Trans. (Lower)  
 Chev; SSR; 2003; V-8 5.3 Eng.; Inlet Fitting To Trans. (Upper)  
 Chev; SSR; 2003; V-8 5.3 Eng.; Outlet Fitting To Trans. (Lower)  
 Chev; Suburban; 2003-2000; V-8 5.3 Eng.; Inlet Fitting To Trans. (Upper)  
 Chev; Suburban; 1999-1996; V-8 5.7 Eng.; Quick Connect Tube Fitting (Lower)  
 Chev; Suburban; 1999-1998; V-8 5.7 Eng.; Quick Connect Tube Fitting (Upper)  
 Chev; Suburban; 1997-1996; V-8 5.7 Eng.; Quick Connect Tube Fitting (Upper); W/Fact Fitting  
 Chev; Suburban; 2003-2000; V-8 6.0 Eng.; Quick Connect Tube Fitting (Lower)  
 Chev; Suburban; 2003-2000; V-8 6.0 Eng.; Quick Connect Tube Fitting (Upper)  
 Chev; Suburban; 1999-1996; V-8 6.5 Diesel Eng.; Quick Connect Tube Fitting (Lower)  
 Chev; Suburban; 1999-1997; V-8 6.5 Diesel Eng.; Quick Connect Tube Fitting (Upper)  
 Chev; Suburban; 1996; V-8 6.5 Diesel Eng.; Quick Connect Tube Fitting (Upper); W/Fact Fitting  
 Chev; Suburban; 1999-1996; V-8 7.4 Eng.; Quick Connect Tube Fitting (Lower)  
 Chev; Suburban; 1999-1996; V-8 7.4 Eng.; Quick Connect Tube Fitting (Upper)  
 Chev; Suburban; 2003-2001; V-8 8.1 Eng.; Quick Connect Tube Fitting (Lower)  
 Chev; Suburban; 2003-2001; V-8 8.1 Eng.; Quick Connect Tube Fitting (Upper)  
 Chev; Tahoe; 2003-2000; V-8 4.8 Eng.; Inlet Fitting To Trans. (Upper)  
 Chev; Tahoe; 2003-2000; V-8 5.3 Eng.; Inlet Fitting To Trans. (Upper)  
 Chev; Tahoe; 2000-1996; V-8 5.7 Eng.; Quick Connect Tube Fitting (Lower)  
 Chev; Tahoe; 2000-1996; V-8 5.7 Eng.; Quick Connect Tube Fitting (Upper)  
 Chev; Tahoe; 1999-1996; V-8 6.5 Diesel Eng.; Quick Connect Tube Fitting (Lower)  
 Chev; Tahoe; 1999-1997; V-8 6.5 Diesel Eng.; Quick Connect Tube Fitting (Upper)  
 Chev; Tahoe; 1996; V-8 6.5 Diesel Eng.; Quick Connect Tube Fitting (Upper); W/Fact Fitting  
 Chev; Trailblazer; 2004-2002; 6-Cyl. 4.2 Eng.; Inlet Fitting To Trans. (Lower)  
 Chev; Trailblazer; 2004-2002; 6-Cyl. 4.2 Eng.; Outlet Fitting To Trans. (Upper)  
 Chev; Trailblazer; 2004-2003; V-8 5.3 Eng.; Inlet Fitting To Trans. (Upper)  
 Chev; Venture; 2003-2000; V-6 3.4 Eng.; Inlet Fitting To Trans. (Upper)  
 Chev; Venture; 2003-2000; V-6 3.4 Eng.; Outlet Fitting To Trans. (Lower)  
 GMC; C&K Pickup; 1998-1997; V-6 4.3 Eng.; Quick Connect Tube Fitting (Lower)  
 GMC; C&K Pickup; 1998-1997; V-6 4.3 Eng.; Quick Connect Tube Fitting (Upper)

# Numerical Listing - Oil Cooler Assemblies & End Fittings

## A63021 - Continued

GMC; C&K Pickup; 1996; V-6 4.3 Eng.; Quick Connect Tube Fitting; W/Fact Fitting; 2 Reqd  
 GMC; C&K Pickup; 1999-1997; V-8 5.0 Eng.; Quick Connect Tube Fitting (Lower)  
 GMC; C&K Pickup; 1999-1997; V-8 5.0 Eng.; Quick Connect Tube Fitting (Upper)  
 GMC; C&K Pickup; 1996; V-8 5.0 Eng.; Quick Connect Tube Fitting; W/Fact Fitting; 2 Reqd  
 GMC; C&K Pickup; 2000-1996; V-8 5.7 Eng.; Quick Connect Tube Fitting (Lower)  
 GMC; C&K Pickup; 2000-1996; V-8 5.7 Eng.; Quick Connect Tube Fitting (Upper)  
 GMC; C&K Pickup; 2002-1996; V-8 6.5 Diesel Eng.; Quick Connect Tube Fitting (Lower)  
 GMC; C&K Pickup; 2002-1996; V-8 6.5 Diesel Eng.; Quick Connect Tube Fitting (Upper)  
 GMC; C&K Pickup; 2000-1996; V-8 7.4 Eng.; Quick Connect Tube Fitting (Lower)  
 GMC; C&K Pickup; 2000-1996; V-8 7.4 Eng.; Quick Connect Tube Fitting (Upper); W/Fact Fitting  
 GMC; C&K Pickup; 2002-2001; V-8 8.1 Eng.; Quick Connect Tube Fitting (Lower)  
 GMC; C&K Pickup; 2002-2001; V-8 8.1 Eng.; Quick Connect Tube Fitting (Upper)  
 GMC; Envoy; 2004-2002; 6-Cyl. 4.2 Eng.; Inlet Fitting To Trans. (Lower)  
 GMC; Envoy; 2004-2002; 6-Cyl. 4.2 Eng.; Outlet Fitting To Trans. (Upper)  
 GMC; Envoy; 2004-2003; V-8 5.3 Eng.; Inlet Fitting To Trans. (Upper)  
 GMC; Jimmy; 2001-1996; V-6 4.3 Eng.; Inlet Fitting To Trans. (Lower)  
 GMC; Jimmy; 2001-1996; V-6 4.3 Eng.; Outlet Fitting To Trans. (Upper)  
 GMC; Jimmy; 2004-2002; V-6 4.3 (Canada) Eng.; Inlet Fitting To Trans. (Lower)  
 GMC; Jimmy; 2004-2002; V-6 4.3 (Canada) Eng.; Outlet Fitting To Trans. (Upper)  
 GMC; Safari; 2005-1996; V-6 4.3 Eng.; Inlet Fitting To Trans. (Upper)  
 GMC; Safari; 2005-1996; V-6 4.3 Eng.; Outlet Fitting To Trans. (Lower)  
 GMC; Savana; 2003; V-6 4.3 Eng.; Connector From Rad; W/16-Bolt Trans. Pan (M30); 2 Reqd  
 GMC; Savana; 2003; V-6 4.3 Eng.; Quick Connect Tube Fitting (Lower); W/16-Bolt Trans. Pan (M30)  
 GMC; Savana; 2003; V-6 4.3 Eng.; Quick Connect Tube Fitting (Upper); W/16-Bolt Trans. Pan (M30)  
 GMC; Savana; 2002-1996; V-6 4.3 Eng.; Inlet Fitting To Trans. (Upper); W/16-Bolt Trans. Pan (M30)  
 GMC; Savana; 2002-1996; V-6 4.3 Eng.; Outlet Fitting To Trans. (Lower); W/16-Bolt Trans. Pan (M30)  
 GMC; Savana; 2003; V-8 4.8 Eng.; Quick Connect Tube Fitting (Lower); W/O Aux. Cooler; 2 Reqd  
 GMC; Savana; 2003; V-8 4.8 Eng.; Quick Connect Tube Fitting (Upper); W/O Aux. Cooler; 2 Reqd  
 GMC; Savana; 2002-1996; V-8 5.0 Eng.; Inlet Fitting To Trans. (Upper)  
 GMC; Savana; 2002-1996; V-8 5.0 Eng.; Outlet Fitting To Trans. (Lower)  
 GMC; Savana; 2003; V-8 5.3 Eng.; Inlet Fitting To Trans. (Upper)  
 GMC; Savana; 2003; V-8 5.3 Eng.; Outlet Fitting To Trans. (Lower)  
 GMC; Savana; 2002-1996; V-8 5.7 Eng.; Inlet Fitting To Trans. (Upper); W/16-Bolt Trans. Pan (M30)  
 GMC; Savana; 2002-2001; V-8 5.7 Eng.; Outlet Fitting To Trans. (Lower)  
 GMC; Savana; 2000-1996; V-8 5.7 Eng.; Outlet Fitting To Trans. (Lower); W/16-Bolt Trans. Pan (M30)  
 GMC; Savana; 1997; V-8 5.7 Eng.; Inlet Fitting To Trans. (Upper); W/17-Bolt Trans. Pan (MT1)  
 GMC; Savana; 2002-1997; V-8 6.5 Diesel Eng.; Inlet Fitting To Trans. (Upper)  
 GMC; Savana; 2002-1997; V-8 6.5 Diesel Eng.; Outlet Fitting To Trans. (Lower)  
 GMC; Savana; 2000-1997; V-8 7.4 Eng.; Inlet Fitting To Trans. (Upper)  
 GMC; Savana; 2000-1997; V-8 7.4 Eng.; Outlet Fitting To Trans. (Lower)  
 GMC; Savana; 2002-2001; V-8 8.1 Eng.; Inlet Fitting To Trans. (Upper)  
 GMC; Savana; 2002-2001; V-8 8.1 Eng.; Outlet Fitting To Trans. (Lower)  
 GMC; Sierra Pickup; 2003-1999; V-6 4.3 Eng.; Inlet Fitting To Trans. (Upper)  
 GMC; Sierra Pickup; 2003-1999; V-8 4.8 Eng.; Inlet Fitting To Trans. (Upper)  
 GMC; Sierra Pickup; 2003-1999; V-8 5.3 Eng.; Inlet Fitting To Trans. (Upper)  
 GMC; Sierra Pickup; 2003; V-8 6.0 Eng.; Quick Connect Tube Fitting (Lower)  
 GMC; Sierra Pickup; 2003-2002; V-8 6.0 Eng.; Quick Connect Tube Fitting (Upper)  
 GMC; Sierra Pickup; 2002-2001; V-8 6.0 Eng.; Quick Connect Tube Fitting (Lower); W/17-Bolt Trans. Pan (MT1)  
 GMC; Sierra Pickup; 2001; V-8 6.0 Eng.; Quick Connect Tube Fitting (Lower); W/16-Bolt Trans. Pan (M30)  
 GMC; Sierra Pickup; 2001; V-8 6.0 Eng.; Quick Connect Tube Fitting (Upper); W/16-Bolt Trans. Pan (M30)

## A63021 - Continued

GMC; Sierra Pickup; 2001; V-8 6.0 Eng.; Quick Connect Tube Fitting (Upper); W/17-Bolt Trans. Pan (MT1)  
 GMC; Sierra Pickup; 2000-1999; V-8 6.0 Eng.; Quick Connect Tube Fitting (Lower)  
 GMC; Sierra Pickup; 2000-1999; V-8 6.0 Eng.; Quick Connect Tube Fitting (Upper)  
 GMC; Sierra Pickup; 1999; V-8 6.5 Diesel Eng.; Quick Connect Tube Fitting (Lower)  
 GMC; Sierra Pickup; 1999; V-8 6.5 Diesel Eng.; Quick Connect Tube Fitting (Upper)  
 GMC; Sierra Pickup; 2003-2001; V-8 8.1 Eng.; Inlet Fitting To Trans. (Upper)  
 GMC; Sierra Pickup; 2003-2001; V-8 8.1 Eng.; Outlet Fitting To Trans. (Lower)  
 GMC; Sonoma; 2003-1998; 4-Cyl. 2.2 Eng.; Inlet Fitting To Trans. (Lower)  
 GMC; Sonoma; 2003-1998; 4-Cyl. 2.2 Eng.; Outlet Fitting To Trans. (Upper)  
 GMC; Sonoma; 2004-1996; V-6 4.3 Eng.; Inlet Fitting To Trans. (Lower)  
 GMC; Sonoma; 2004-1996; V-6 4.3 Eng.; Outlet Fitting To Trans. (Upper)  
 GMC; Suburban; 1999-1996; V-8 5.7 Eng.; Quick Connect Tube Fitting (Lower)  
 GMC; Suburban; 1999-1998; V-8 5.7 Eng.; Quick Connect Tube Fitting (Upper)  
 GMC; Suburban; 1997-1996; V-8 5.7 Eng.; Quick Connect Tube Fitting (Upper); W/Fact Fitting  
 GMC; Suburban; 1999-1996; V-8 6.5 Diesel Eng.; Quick Connect Tube Fitting (Lower)  
 GMC; Suburban; 1999-1997; V-8 6.5 Diesel Eng.; Quick Connect Tube Fitting (Upper)  
 GMC; Suburban; 1996; V-8 6.5 Diesel Eng.; Quick Connect Tube Fitting (Upper); W/Fact Fitting  
 GMC; Suburban; 1999-1996; V-8 7.4 Eng.; Quick Connect Tube Fitting (Lower)  
 GMC; Suburban; 1999-1996; V-8 7.4 Eng.; Quick Connect Tube Fitting (Upper)  
 GMC; Yukon; 2003-2000; V-8 4.8 Eng.; Inlet Fitting To Trans. (Upper)  
 GMC; Yukon; 2003-2000; V-8 5.3 Eng.; Inlet Fitting To Trans. (Upper)  
 GMC; Yukon; 2000-1996; V-8 5.7 Eng.; Quick Connect Tube Fitting (Lower)  
 GMC; Yukon; 2000-1998; V-8 5.7 Eng.; Quick Connect Tube Fitting (Upper)  
 GMC; Yukon; 1997-1996; V-8 5.7 Eng.; Quick Connect Tube Fitting (Upper); W/Fact Fitting  
 GMC; Yukon; 2003; V-8 6.0 Eng.; Inlet Fitting To Trans. (Upper)  
 GMC; Yukon; 2003; V-8 6.0 Eng.; Quick Connect Tube Fitting (Lower)  
 GMC; Yukon; 2003; V-8 6.0 Eng.; Quick Connect Tube Fitting (Upper)  
 GMC; Yukon; 2002-2001; V-8 6.0 Eng.; Inlet Fitting To Trans. (Lower)  
 GMC; Yukon; 2002-2001; V-8 6.0 Eng.; Outlet Fitting To Trans. (Upper)  
 GMC; Yukon; 2000; V-8 6.0 Eng.; Outlet Fitting To Trans. Case (Upper)  
 GMC; Yukon; 1997-1996; V-8 6.5 Diesel Eng.; Quick Connect Tube Fitting (Lower)  
 GMC; Yukon; 1997; V-8 6.5 Diesel Eng.; Quick Connect Tube Fitting (Upper)  
 GMC; Yukon; 1996; V-8 6.5 Diesel Eng.; Quick Connect Tube Fitting (Upper); W/Fact Fitting  
 GMC; Yukon; 2003-2001; V-8 8.1 Eng.; Quick Connect Tube Fitting (Lower)  
 GMC; Yukon; 2003-2001; V-8 8.1 Eng.; Quick Connect Tube Fitting (Upper)  
 Olds; Aurora; 2002-2001; V-6 3.5 Eng.; Inlet Fitting To Trans. (Upper)  
 Olds; Bravada; 2003-2002; 6-Cyl. 4.2 Eng.; Inlet Fitting To Trans. (Lower)  
 Olds; Bravada; 2003-2002; 6-Cyl. 4.2 Eng.; Outlet Fitting To Trans. (Upper)  
 Olds; Bravada; 2001-1996; V-6 4.3 Eng.; Inlet Fitting To Trans. (Lower)  
 Olds; Bravada; 2001-1996; V-6 4.3 Eng.; Outlet Fitting To Trans. (Upper)  
 Olds; Intrigue; 2002-2000; V-6 3.5 Eng.; Inlet Fitting To Trans. (Upper)  
 Olds; Silhouette; 2003-2000; V-6 3.4 Eng.; Inlet Fitting To Trans. (Upper)  
 Olds; Silhouette; 2003-2000; V-6 3.4 Eng.; Outlet Fitting To Trans. (Lower)  
 Pont; Aztek; 2003-2001; V-6 3.4 Eng.; Inlet Fitting To Trans. (Upper)  
 Pont; Bonneville; 2003-2000; V-6 3.8 Eng.; Inlet Fitting To Trans. (Upper)  
 Pont; Firebird; 2002-1998; V-6 3.8 Eng.; Inlet Fitting To Trans. (Upper)  
 Pont; Firebird; 2002-1998; V-6 3.8 Eng.; Outlet Fitting To Trans. (Lower)  
 Pont; Firebird; 2002-1998; V-8 5.7 Eng.; Inlet Fitting To Trans. (Upper)  
 Pont; Firebird; 2002-1998; V-8 5.7 Eng.; Outlet Fitting To Trans. (Lower)  
 Pont; Grand Prix; 2003-2000; V-6 3.1 Eng.; Inlet Fitting To Trans. (Upper)  
 Pont; Grand Prix; 2003-2000; V-6 3.8 Eng.; Inlet Fitting To Trans. (Upper)  
 Pont; Montana; 2003-2000; V-6 3.4 Eng.; Inlet Fitting To Trans. (Upper)  
 Pont; Montana; 2000; V-6 3.4 Eng.; Outlet Fitting To Trans. (Lower)

## A63025

Cad; Deville; 2003-2001; V-8 4.6 Eng.; Outlet Fitting To Trans. (Lower); W/Quick Connect Fitting

## Numerical Listing - Oil Cooler Assemblies & End Fittings

### A63025 - Continued

Cad; Eldorado; 2002-2001; V-8 4.6 Eng.; Outlet Fitting To Trans. (Lower); W/Quick Connect Fitting  
 Cad; Seville; 2003-2001; V-8 4.6 Eng.; Outlet Fitting To Trans. (Lower); W/Quick Connect Fitting  
 Olds; Aurora; 2003-2001; V-8 4.0 Eng.; Outlet Fitting To Trans. (Lower); W/Quick Connect Fitting  
 Olds; Aurora; 1999-1995; V-8 4.0 Eng.; Outlet Fitting To Trans. (Lower); W/Quick Connect Fitting

### A63027

Chev; C&K Pickup; 2000-1997; V-8 5.7 Eng.; Inlet Fitting To Trans. Case (Upper); W/Fact Fitting; W/17-Bolt Trans. Pan (MT1)  
 Chev; C&K Pickup; 2002-2001; V-8 6.5 Diesel Eng.; Inlet Fitting To Trans. Case (Upper); W/Fact Fitting  
 Chev; C&K Pickup; 2000-1997; V-8 6.5 Diesel Eng.; Inlet Fitting To Trans. Case (Upper)  
 Chev; C&K Pickup; 2000-1997; V-8 7.4 Eng.; Inlet Fitting To Trans. Case (Upper)  
 Chev; C&K Pickup; 2002-2001; V-8 8.1 Eng.; Inlet Fitting To Trans. Case (Upper); W/Fact Fitting  
 Chev; Express; 2003-1997; V-6 4.3 Eng.; Inlet Fitting To Trans. Case (Upper); W/17-Bolt Trans. Pan (MT1)  
 Chev; Express; 2003; V-6 4.3 Eng.; Outlet Fitting To Trans. Case (Lower); W/17-Bolt Trans. Pan (MT1)  
 Chev; Express; 2003; V-8 4.8 Eng.; Inlet Fitting From Rad (Upper); W/Aux. Cooler  
 Chev; Express; 2003; V-8 4.8 Eng.; Inlet Fitting To Trans. (Upper); W/Aux. Cooler  
 Chev; Express; 2003; V-8 4.8 Eng.; Outlet Fitting From Rad (Lower); W/Aux. Cooler  
 Chev; Express; 2003; V-8 4.8 Eng.; Outlet Fitting To Trans. (Lower); W/Aux. Cooler  
 Chev; Express; 2002-2001; V-8 5.7 Eng.; Inlet Fitting To Trans. (Upper); W/17-Bolt Trans. Pan (MT1)  
 Chev; Express; 2000-1997; V-8 5.7 Eng.; Inlet Fitting To Trans. Case (Upper); W/17-Bolt Trans. Pan (MT1)  
 Chev; Express; 2003; V-8 6.0 Eng.; Inlet Fitting From Rad (Upper)  
 Chev; Express; 2003; V-8 6.0 Eng.; Inlet Fitting To Trans. (Upper)  
 Chev; Express; 2003; V-8 6.0 Eng.; Outlet Fitting From Rad (Lower)  
 Chev; Express; 2003; V-8 6.0 Eng.; Outlet Fitting To Trans. (Lower)  
 Chev; Express; 2002-1997; V-8 6.5 Diesel Eng.; Inlet Fitting To Trans. Case (Upper)  
 Chev; Express; 2000-1997; V-8 7.4 Eng.; Inlet Fitting To Trans. Case (Upper)  
 Chev; Express; 2002-2001; V-8 8.1 Eng.; Inlet Fitting To Trans. Case (Upper)  
 Chev; G Van; 1998-1997; V-6 4.3 Eng.; Inlet Fitting To Trans. Case (Upper); W/17-Bolt Trans. Pan (MT1)  
 Chev; G Van; 1998-1997; V-8 5.7 Eng.; Inlet Fitting To Trans. Case (Upper); W/17-Bolt Trans. Pan (MT1)  
 Chev; G Van; 1998-1997; V-8 6.5 Diesel Eng.; Inlet Fitting To Trans. Case (Upper)  
 Chev; G Van; 1998-1997; V-8 7.4 Eng.; Inlet Fitting To Trans. Case (Upper)  
 Chev; Silverado Pickup; 2003; V-8 6.0 Eng.; Inlet Fitting To Trans. (Lower)  
 Chev; Silverado Pickup; 2002-2001; V-8 6.0 Eng.; Inlet Fitting To Trans. Case (Lower); W/17-Bolt Trans. Pan (MT1)  
 Chev; Silverado Pickup; 2000-1999; V-8 6.0 Eng.; Inlet Fitting To Trans. Case (Lower)  
 Chev; Silverado Pickup; 1999; V-8 6.5 Diesel Eng.; Inlet Fitting To Trans. Case (Upper); W/Fact Fitting  
 Chev; Suburban; 1999-1997; V-8 5.7 Eng.; Inlet Fitting To Trans. Case (Upper); W/Fact Fitting; W/17-Bolt Trans. Pan (MT1)  
 Chev; Suburban; 2003-2001; V-8 6.0 Eng.; Inlet Fitting To Trans. (Lower)  
 Chev; Suburban; 2000; V-8 6.0 Eng.; Inlet Fitting To Trans. Case (Lower)  
 Chev; Suburban; 1999-1997; V-8 6.5 Diesel Eng.; Inlet Fitting To Trans. Case (Upper); W/Fact Fitting  
 Chev; Suburban; 1999-1996; V-8 7.4 Eng.; Inlet Fitting To Trans. Case (Upper); W/Fact Fitting  
 Chev; Suburban; 2003; V-8 8.1 Eng.; Inlet Fitting To Trans. Case (Lower)  
 Chev; Suburban; 2002-2001; V-8 8.1 Eng.; Inlet Fitting To Trans. (Lower)  
 Chev; Tahoe; 1999-1997; V-8 6.5 Diesel Eng.; Inlet Fitting To Trans. Case (Upper); W/Fact Fitting  
 GMC; C&K Pickup; 2000-1997; V-8 5.7 Eng.; Inlet Fitting To Trans. Case (Upper); W/Fact Fitting; W/17-Bolt Trans. Pan (MT1)  
 GMC; C&K Pickup; 2002-2001; V-8 6.5 Diesel Eng.; Inlet Fitting To Trans. Case (Upper); W/Fact Fitting  
 GMC; C&K Pickup; 2000-1997; V-8 6.5 Diesel Eng.; Inlet Fitting To Trans. Case (Upper)  
 GMC; C&K Pickup; 2000-1996; V-8 7.4 Eng.; Inlet Fitting To Trans. Case (Upper)

### A63027 - Continued

GMC; C&K Pickup; 2002-2001; V-8 8.1 Eng.; Inlet Fitting To Trans. Case (Upper); W/Fact Fitting  
 GMC; Savana; 2003-1997; V-6 4.3 Eng.; Inlet Fitting To Trans. Case (Upper); W/17-Bolt Trans. Pan (MT1)  
 GMC; Savana; 2003; V-6 4.3 Eng.; Outlet Fitting To Trans. Case (Lower); W/17-Bolt Trans. Pan (MT1)  
 GMC; Savana; 2003; V-8 4.8 Eng.; Inlet Fitting From Rad (Upper); W/Aux. Cooler  
 GMC; Savana; 2003; V-8 4.8 Eng.; Inlet Fitting To Trans. (Upper); W/Aux. Cooler  
 GMC; Savana; 2003; V-8 4.8 Eng.; Outlet Fitting From Rad (Lower); W/Aux. Cooler  
 GMC; Savana; 2003; V-8 4.8 Eng.; Outlet Fitting To Trans. (Lower); W/Aux. Cooler  
 GMC; Savana; 2002-2001; V-8 5.7 Eng.; Inlet Fitting To Trans. (Upper); W/17-Bolt Trans. Pan (MT1)  
 GMC; Savana; 2000-1997; V-8 5.7 Eng.; Inlet Fitting To Trans. Case (Upper); W/17-Bolt Trans. Pan (MT1)  
 GMC; Savana; 2003; V-8 6.0 Eng.; Inlet Fitting From Rad (Upper)  
 GMC; Savana; 2003; V-8 6.0 Eng.; Inlet Fitting To Trans. (Upper)  
 GMC; Savana; 2003; V-8 6.0 Eng.; Outlet Fitting From Rad (Lower)  
 GMC; Savana; 2003; V-8 6.0 Eng.; Outlet Fitting To Trans. (Lower)  
 GMC; Savana; 2002-1997; V-8 6.5 Diesel Eng.; Inlet Fitting To Trans. Case (Upper)  
 GMC; Savana; 2000-1997; V-8 7.4 Eng.; Inlet Fitting To Trans. Case (Upper)  
 GMC; Savana; 2002-2001; V-8 8.1 Eng.; Inlet Fitting To Trans. Case (Upper)  
 GMC; Sierra Pickup; 2003; V-8 6.0 Eng.; Inlet Fitting To Trans. (Lower)  
 GMC; Sierra Pickup; 2002-2001; V-8 6.0 Eng.; Inlet Fitting To Trans. Case (Lower); W/17-Bolt Trans. Pan (MT1)  
 GMC; Sierra Pickup; 2000; V-8 6.0 Eng.; Inlet Fitting To Trans. Case (Lower); 2500  
 GMC; Sierra Pickup; 1999; V-8 6.0 Eng.; Inlet Fitting To Trans. Case (Lower)  
 GMC; Sierra Pickup; 1999; V-8 6.5 Diesel Eng.; Inlet Fitting To Trans. Case (Upper); W/Fact Fitting  
 GMC; Suburban; 1999-1997; V-8 5.7 Eng.; Inlet Fitting To Trans. Case (Upper); W/Fact Fitting; W/17-Bolt Trans. Pan (MT1)  
 GMC; Suburban; 1999-1997; V-8 6.5 Diesel Eng.; Inlet Fitting To Trans. Case (Upper); W/Fact Fitting  
 GMC; Suburban; 1999-1996; V-8 7.4 Eng.; Inlet Fitting To Trans. Case (Upper); W/Fact Fitting  
 GMC; Yukon; 1999-1997; V-8 5.7 Eng.; Inlet Fitting To Trans. Case (Upper); W/Fact Fitting; W/17-Bolt Trans. Pan (MT1)  
 GMC; Yukon; 2003; V-8 6.0 Eng.; Inlet Fitting To Trans. (Lower)  
 GMC; Yukon; 2000; V-8 6.0 Eng.; Inlet Fitting To Trans. Case (Lower)  
 GMC; Yukon; 1997; V-8 6.5 Diesel Eng.; Inlet Fitting To Trans. Case (Upper); W/Fact Fitting  
 GMC; Yukon; 2003-2001; V-8 8.1 Eng.; Inlet Fitting To Trans. (Lower)

### A63032

Dodge; B Van; 2003-1994; V-6 3.9 Eng.; Connector From Rad; 2 Reqd  
 Dodge; B Van; 2003-1994; V-6 3.9 Eng.; Inlet Fitting To Trans.; W/Quick Connect Fitting  
 Dodge; B Van; 2003-1994; V-6 3.9 Eng.; Outlet Fitting To Trans.; W/Quick Connect Fitting  
 Dodge; B Van; 2003-1994; V-8 5.2 Eng.; Connector From Rad; 2 Reqd  
 Dodge; B Van; 2003-1994; V-8 5.2 Eng.; Inlet Fitting To Trans.; W/Quick Connect Fitting  
 Dodge; B Van; 2003-1994; V-8 5.2 Eng.; Outlet Fitting To Trans.; W/Quick Connect Fitting  
 Dodge; B Van; 2003-1994; V-8 5.9 Eng.; Connector From Rad; 2 Reqd  
 Dodge; B Van; 2003-1994; V-8 5.9 Eng.; Inlet Fitting To Trans.; W/Quick Connect Fitting  
 Dodge; B Van; 2003-1994; V-8 5.9 Eng.; Outlet Fitting To Trans.; W/Quick Connect Fitting  
 Dodge; Dakota; 1996-1994; V-6 3.9 Eng.; Inlet Fitting To Trans.; W/Quick Connect Tube  
 Dodge; Dakota; 1996-1994; V-6 3.9 Eng.; Outlet Fitting To Trans.; W/Quick Connect Tube  
 Dodge; Dakota; 1996-1994; V-8 5.2 Eng.; Inlet Fitting To Trans.; W/Quick Connect Tube  
 Dodge; Dakota; 1996-1994; V-8 5.2 Eng.; Outlet Fitting To Trans.; W/Quick Connect Tube  
 Dodge; Ram Pickup; 1996-1994; V-6 3.9 Eng.; Inlet Fitting To Trans.  
 Dodge; Ram Pickup; 1996-1994; V-6 3.9 Eng.; Outlet Fitting To Trans.  
 Dodge; Ram Pickup; 1995-1994; V-8 5.2 Eng.; Inlet Fitting To Trans.  
 Dodge; Ram Pickup; 1995-1994; V-8 5.2 Eng.; Outlet Fitting To Trans.  
 Dodge; Ram Pickup; 1995-1994; V-8 5.9 Eng.; Inlet Fitting To Trans.  
 Dodge; Ram Pickup; 1995-1994; V-8 5.9 Eng.; Outlet Fitting To Trans.  
 Jeep; Cherokee; 1996-1994; 4-Cyl. 2.5 Eng.; Inlet Fitting To Trans.  
 Jeep; Cherokee; 1996-1994; 4-Cyl. 2.5 Eng.; Outlet Fitting To Trans.

## Numerical Listing - Oil Cooler Assemblies & End Fittings

### A63032 - Continued

Jeep; Cherokee; 1993-1988; 4-Cyl. 2.5 Eng.; Inlet Fitting To Trans.; W/Fact Fitting  
 Jeep; Cherokee; 1993-1988; 4-Cyl. 2.5 Eng.; Outlet Fitting To Trans.; W/Fact Fitting  
 Jeep; Cherokee; 1996-1988; 6-Cyl. 4.0 Eng.; Inlet Fitting To Trans.  
 Jeep; Cherokee; 1996-1988; 6-Cyl. 4.0 Eng.; Outlet Fitting To Trans.  
 Jeep; Comanche; 1992-1988; 4-Cyl. 2.5 Eng.; Inlet Fitting To Trans.; W/Fact Fitting  
 Jeep; Comanche; 1992-1988; 4-Cyl. 2.5 Eng.; Outlet Fitting To Trans.; W/Fact Fitting  
 Jeep; Comanche; 1992-1988; 6-Cyl. 4.0 Eng.; Inlet Fitting To Trans.  
 Jeep; Comanche; 1992-1988; 6-Cyl. 4.0 Eng.; Outlet Fitting To Trans.  
 Jeep; Grand Cherokee; 1997-1994; 6-Cyl. 4.0 Eng.; Outlet Fitting To Trans. (Rear)  
 Jeep; Grand Cherokee; 1996-1994; 6-Cyl. 4.0 Eng.; Inlet Fitting To Trans. (Front)  
 Jeep; Grand Cherokee; 1997-1996; V-8 5.2 Eng.; Outlet Fitting To Trans. (Rear)  
 Jeep; Grand Cherokee; 1995-1993; V-8 5.2 Eng.; Inlet Fitting To Trans.  
 Jeep; Grand Cherokee; 1995-1993; V-8 5.2 Eng.; Outlet Fitting To Trans.  
 Jeep; Grand Cherokee; 1998; V-8 5.9 Eng.; Outlet Fitting To Trans. (Rear)  
 Jeep; Wagoneer; 1990-1988; 6-Cyl. 4.0 Eng.; Inlet Fitting To Trans.  
 Jeep; Wagoneer; 1990-1988; 6-Cyl. 4.0 Eng.; Outlet Fitting To Trans.  
 Jeep; Wrangler; 2002-2001; 4-Cyl. 2.5 Eng.; Outlet Fitting To Trans. (Rear)  
 Jeep; Wrangler; 2000-1997; 4-Cyl. 2.5 Eng.; Inlet Fitting To Trans.  
 Jeep; Wrangler; 2000-1997; 4-Cyl. 2.5 Eng.; Outlet Fitting To Trans.  
 Jeep; Wrangler; 1995-1994; 4-Cyl. 2.5 Eng.; Inlet Fitting To Trans.  
 Jeep; Wrangler; 1995-1994; 4-Cyl. 2.5 Eng.; Outlet Fitting To Trans.  
 Jeep; Wrangler; 2002-2000; 6-Cyl. 4.0 Eng.; Inlet Fitting To Trans.  
 Jeep; Wrangler; 2002-2000; 6-Cyl. 4.0 Eng.; Outlet Fitting To Trans.  
 Jeep; Wrangler; 1999-1997; 6-Cyl. 4.0 Eng.; Outlet Fitting To Trans. (Rear)  
 Jeep; Wrangler; 1995-1994; 6-Cyl. 4.0 Eng.; Inlet Fitting To Trans.  
 Jeep; Wrangler; 1995-1994; 6-Cyl. 4.0 Eng.; Outlet Fitting To Trans. (Rear); W/Fact Fitting

### A63033

Dodge; D & W Pickup; 1993-1989; 6-Cyl. 5.9 Diesel Eng.; Inlet Fitting To Trans.  
 Dodge; D & W Pickup; 1993-1989; 6-Cyl. 5.9 Diesel Eng.; Outlet Fitting To Trans.  
 Dodge; Ram Pickup; 2003; 6-Cyl. 5.9 Diesel Eng.; Inlet Fitting To Trans.  
 Dodge; Ram Pickup; 2003; 6-Cyl. 5.9 Diesel Eng.; Outlet Fitting To Trans.  
 Dodge; Ram Pickup; 2002-1994; 6-Cyl. 5.9 Diesel Eng.; Inlet Fitting To Trans.; W/4-Spd 47RE Trans.  
 Dodge; Ram Pickup; 2002-1994; 6-Cyl. 5.9 Diesel Eng.; Outlet Fitting To Trans.; W/4-Spd 47RE Trans.  
 Dodge; Ram Pickup; 2003-2002; V-6 3.7 Eng.; Inlet Fitting To Trans.  
 Dodge; Ram Pickup; 2003-2002; V-6 3.7 Eng.; Outlet Fitting To Trans.  
 Dodge; Ram Pickup; 2003-2002; V-8 4.7 Eng.; Inlet Fitting To Trans.  
 Dodge; Ram Pickup; 2003-2002; V-8 4.7 Eng.; Outlet Fitting To Trans.  
 Dodge; Ram Pickup; 2003; V-8 5.7 Eng.; Inlet Fitting To Trans.  
 Dodge; Ram Pickup; 2003; V-8 5.7 Eng.; Outlet Fitting To Trans.  
 Dodge; Ram Pickup; 2003; V-10 8.0 Eng.; Inlet Fitting To Trans.  
 Dodge; Ram Pickup; 2003; V-10 8.0 Eng.; Outlet Fitting To Trans.  
 Dodge; Ram Pickup; 2001-1997; V-10 8.0 Eng.; Inlet Fitting To Trans.; W/4-Spd 47RE Trans.  
 Dodge; Ram Pickup; 2001-1997; V-10 8.0 Eng.; Outlet Fitting To Trans.; W/4-Spd 47RE Trans.

### A63035

Chry; Concorde; 2004-1998; V-6 2.7 Eng.; Inlet Fitting To Trans. (Lower)  
 Chry; Concorde; 2004-1998; V-6 2.7 Eng.; Outlet Fitting To Trans. (Upper)  
 Chry; Concorde; 2001-1998; V-6 3.2 Eng.; Inlet Fitting To Trans. (Upper)  
 Chry; Concorde; 2001-1998; V-6 3.2 Eng.; Outlet Fitting To Trans. (Lower)  
 Chry; Concorde; 1996-1993; V-6 3.3 Eng.; Inlet Fitting To Trans. (Upper)  
 Chry; Concorde; 1996-1993; V-6 3.3 Eng.; Outlet Fitting To Trans. (Lower)  
 Chry; Concorde; 2004-2002; V-6 3.5 Eng.; Inlet Fitting To Trans. (Upper)  
 Chry; Concorde; 2004-2002; V-6 3.5 Eng.; Outlet Fitting To Trans. (Lower)  
 Chry; Concorde; 1997-1993; V-6 3.5 Eng.; Inlet Fitting To Trans. (Upper)  
 Chry; Concorde; 1997-1993; V-6 3.5 Eng.; Outlet Fitting To Trans. (Lower)  
 Chry; LHS; 2001-1999; V-6 3.5 Eng.; Inlet Fitting To Trans. (Upper)  
 Chry; LHS; 2001-1999; V-6 3.5 Eng.; Outlet Fitting To Trans. (Lower)  
 Chry; LHS; 1997-1994; V-6 3.5 Eng.; Inlet Fitting To Trans. (Upper)  
 Chry; LHS; 1997-1994; V-6 3.5 Eng.; Outlet Fitting To Trans. (Lower)  
 Chry; New Yorker; 1996-1994; V-6 3.5 Eng.; Inlet Fitting To Trans. (Upper)  
 Chry; New Yorker; 1996-1994; V-6 3.5 Eng.; Outlet Fitting To Trans. (Lower)

### A63035 - Continued

Chry; 300M; 2004-1999; V-6 3.5 Eng.; Inlet Fitting To Trans. (Upper)  
 Chry; 300M; 2004-1999; V-6 3.5 Eng.; Outlet Fitting To Trans. (Lower)  
 Dodge; B Van; 2003-1994; V-6 3.9 Eng.; Inlet Fitting To Trans.; W/Male Fitting  
 Dodge; B Van; 2003-1994; V-6 3.9 Eng.; Outlet Fitting To Trans.; W/Male Fitting  
 Dodge; B Van; 1993-1990; V-6 3.9 Eng.; Inlet Fitting To Trans.  
 Dodge; B Van; 1993-1990; V-6 3.9 Eng.; Outlet Fitting To Trans.  
 Dodge; B Van; 2003-1994; V-8 5.2 Eng.; Inlet Fitting To Trans.; W/Male Fitting  
 Dodge; B Van; 2003-1994; V-8 5.2 Eng.; Outlet Fitting To Trans.; W/Male Fitting  
 Dodge; B Van; 1993-1990; V-8 5.2 Eng.; Inlet Fitting To Trans.  
 Dodge; B Van; 1993-1990; V-8 5.2 Eng.; Outlet Fitting To Trans.  
 Dodge; B Van; 2003-1994; V-8 5.9 Eng.; Inlet Fitting To Trans.; W/Male Fitting  
 Dodge; B Van; 2003-1994; V-8 5.9 Eng.; Outlet Fitting To Trans.; W/Male Fitting  
 Dodge; B Van; 1993-1990; V-8 5.9 Eng.; Inlet Fitting To Trans.  
 Dodge; B Van; 1993-1990; V-8 5.9 Eng.; Outlet Fitting To Trans.  
 Dodge; D & W Pickup; 1993-1990; V-6 3.9 Eng.; Inlet Fitting To Trans.  
 Dodge; D & W Pickup; 1993-1990; V-6 3.9 Eng.; Outlet Fitting To Trans.  
 Dodge; D & W Pickup; 1993-1990; V-8 5.2 Eng.; Inlet Fitting To Trans.  
 Dodge; D & W Pickup; 1993-1990; V-8 5.2 Eng.; Outlet Fitting To Trans.  
 Dodge; D & W Pickup; 1993-1990; V-8 5.9 Eng.; Inlet Fitting To Trans.  
 Dodge; D & W Pickup; 1993-1990; V-8 5.9 Eng.; Outlet Fitting To Trans.  
 Dodge; Dakota; 2003-1997; V-6 3.9 Eng.; Inlet Fitting To Trans.  
 Dodge; Dakota; 2003-1997; V-6 3.9 Eng.; Outlet Fitting To Trans.  
 Dodge; Dakota; 1996-1994; V-6 3.9 Eng.; Inlet Fitting To Trans.; W/Flared Tube  
 Dodge; Dakota; 1996-1994; V-6 3.9 Eng.; Outlet Fitting To Trans.; W/Flared Tube  
 Dodge; Dakota; 1993-1990; V-6 3.9 Eng.; Inlet Fitting To Trans.  
 Dodge; Dakota; 1993-1990; V-6 3.9 Eng.; Outlet Fitting To Trans.  
 Dodge; Dakota; 1999-1997; V-8 5.2 Eng.; Inlet Fitting To Trans.  
 Dodge; Dakota; 1999-1997; V-8 5.2 Eng.; Outlet Fitting To Trans.  
 Dodge; Dakota; 1996-1994; V-8 5.2 Eng.; Inlet Fitting To Trans.; W/Flared Tube  
 Dodge; Dakota; 1996-1994; V-8 5.2 Eng.; Outlet Fitting To Trans.; W/Flared Tube  
 Dodge; Dakota; 1993-1990; V-8 5.2 Eng.; Inlet Fitting To Trans.  
 Dodge; Dakota; 1993-1990; V-8 5.2 Eng.; Outlet Fitting To Trans.  
 Dodge; Dakota; 2003-1998; V-8 5.9 Eng.; Inlet Fitting To Trans.  
 Dodge; Dakota; 2003-1998; V-8 5.9 Eng.; Outlet Fitting To Trans.  
 Dodge; Durango; 1999-1998; V-6 3.9 Eng.; Inlet Fitting To Trans.  
 Dodge; Durango; 1999-1998; V-6 3.9 Eng.; Outlet Fitting To Trans.  
 Dodge; Durango; 2000-1998; V-8 5.2 Eng.; Inlet Fitting To Trans.  
 Dodge; Durango; 2000-1998; V-8 5.2 Eng.; Outlet Fitting To Trans.  
 Dodge; Durango; 2003-1998; V-8 5.9 Eng.; Inlet Fitting To Trans.  
 Dodge; Durango; 2003-1998; V-8 5.9 Eng.; Outlet Fitting To Trans.  
 Dodge; Intrepid; 2004-1998; V-6 2.7 Eng.; Inlet Fitting To Trans. (Lower)  
 Dodge; Intrepid; 2004-1998; V-6 2.7 Eng.; Outlet Fitting To Trans. (Upper)  
 Dodge; Intrepid; 2001-1998; V-6 3.2 Eng.; Inlet Fitting To Trans. (Upper)  
 Dodge; Intrepid; 2001-1998; V-6 3.2 Eng.; Outlet Fitting To Trans. (Lower)  
 Dodge; Intrepid; 1997-1993; V-6 3.3 Eng.; Inlet Fitting To Trans. (Upper)  
 Dodge; Intrepid; 1997-1993; V-6 3.3 Eng.; Outlet Fitting To Trans. (Lower)  
 Dodge; Intrepid; 2004-2000; V-6 3.5 Eng.; Inlet Fitting To Trans. (Upper)  
 Dodge; Intrepid; 2004-2000; V-6 3.5 Eng.; Outlet Fitting To Trans. (Lower)  
 Dodge; Intrepid; 1997-1993; V-6 3.5 Eng.; Inlet Fitting To Trans. (Upper)  
 Dodge; Intrepid; 1997-1993; V-6 3.5 Eng.; Outlet Fitting To Trans. (Lower)  
 Dodge; Monaco; 1992-1990; V-6 3.0 Eng.; Inlet Fitting To Trans.  
 Dodge; Monaco; 1992-1990; V-6 3.0 Eng.; Outlet Fitting To Trans.  
 Dodge; Ram Pickup; 2002-1994; 6-Cyl. 5.9 Diesel Eng.; Inlet Fitting To Trans.; W/4-Spd 46RE Trans.  
 Dodge; Ram Pickup; 2002-1994; 6-Cyl. 5.9 Diesel Eng.; Outlet Fitting To Trans.; W/4-Spd 46RE Trans.  
 Dodge; Ram Pickup; 2001-1997; V-6 3.9 Eng.; Inlet Fitting To Trans.  
 Dodge; Ram Pickup; 2001-1997; V-6 3.9 Eng.; Outlet Fitting To Trans.  
 Dodge; Ram Pickup; 2001-1996; V-8 5.2 Eng.; Inlet Fitting To Trans.  
 Dodge; Ram Pickup; 2001-1996; V-8 5.2 Eng.; Outlet Fitting To Trans.  
 Dodge; Ram Pickup; 2003-1996; V-8 5.9 Eng.; Inlet Fitting To Trans.  
 Dodge; Ram Pickup; 2003-1996; V-8 5.9 Eng.; Outlet Fitting To Trans.  
 Dodge; Ram Pickup; 2002; V-10 8.0 Eng.; Inlet Fitting To Trans.  
 Dodge; Ram Pickup; 2002; V-10 8.0 Eng.; Outlet Fitting To Trans.  
 Dodge; Ram Pickup; 2001-1997; V-10 8.0 Eng.; Inlet Fitting To Trans.; W/4-Spd 46RE Trans.  
 Dodge; Ram Pickup; 2001-1997; V-10 8.0 Eng.; Outlet Fitting To Trans.; W/4-Spd 46RE Trans.  
 Dodge; Ramcharger; 1993-1990; V-8 5.2 Eng.; Inlet Fitting To Trans.  
 Dodge; Ramcharger; 1993-1990; V-8 5.2 Eng.; Outlet Fitting To Trans.  
 Dodge; Ramcharger; 1993-1990; V-8 5.9 Eng.; Inlet Fitting To Trans.  
 Dodge; Ramcharger; 1993-1990; V-8 5.9 Eng.; Outlet Fitting To Trans.  
 Eagle; Premier; 1992-1988; V-6 3.0 Eng.; Inlet Fitting To Trans.

# Numerical Listing - Oil Cooler Assemblies & End Fittings

## A63035 - Continued

Eagle; Premier; 1992-1988; V-6 3.0 Eng.; Outlet Fitting To Trans.  
 Eagle; Vision; 1996-1993; V-6 3.3 Eng.; Inlet Fitting To Trans. (Upper)  
 Eagle; Vision; 1996-1993; V-6 3.3 Eng.; Outlet Fitting To Trans. (Lower)  
 Eagle; Vision; 1997; V-6 3.3 (Canada) Eng.; Inlet Fitting To Trans. (Upper)  
 Eagle; Vision; 1997; V-6 3.3 (Canada) Eng.; Outlet Fitting To Trans. (Lower)  
 Eagle; Vision; 1997-1993; V-6 3.5 Eng.; Inlet Fitting To Trans. (Upper)  
 Eagle; Vision; 1997-1993; V-6 3.5 Eng.; Outlet Fitting To Trans. (Lower)  
 Jeep; Cherokee; 2000-1997; 4-Cyl. 2.5 Eng.; Inlet Fitting To Trans.  
 Jeep; Cherokee; 2000-1997; 4-Cyl. 2.5 Eng.; Outlet Fitting To Trans.  
 Jeep; Cherokee; 1993-1988; 4-Cyl. 2.5 Eng.; Inlet Fitting To Trans.; Service Item  
 Jeep; Cherokee; 1993-1988; 4-Cyl. 2.5 Eng.; Outlet Fitting To Trans.; Service Item  
 Jeep; Comanche; 1992-1988; 4-Cyl. 2.5 Eng.; Inlet Fitting To Trans.; Service Item  
 Jeep; Comanche; 1992-1988; 4-Cyl. 2.5 Eng.; Outlet Fitting To Trans.; Service Item  
 Jeep; Grand Cherokee; 2003-1998; 6-Cyl. 4.0 Eng.; Inlet Fitting To Trans.  
 Jeep; Grand Cherokee; 2003-1998; 6-Cyl. 4.0 Eng.; Outlet Fitting To Trans.  
 Jeep; Grand Cherokee; 1997; 6-Cyl. 4.0 Eng.; Inlet Fitting To Trans. (Front)  
 Jeep; Grand Cherokee; 1998; V-8 5.2 Eng.; Inlet Fitting To Trans.  
 Jeep; Grand Cherokee; 1998; V-8 5.2 Eng.; Outlet Fitting To Trans.  
 Jeep; Grand Cherokee; 1997-1996; V-8 5.2 Eng.; Inlet Fitting To Trans. (Front)  
 Jeep; Grand Cherokee; 1998; V-8 5.9 Eng.; Inlet Fitting To Trans. (Front)  
 Jeep; Wrangler; 2002-2001; 4-Cyl. 2.5 Eng.; Inlet Fitting To Trans. (Front)  
 Jeep; Wrangler; 1995-1994; 6-Cyl. 4.0 Eng.; Outlet Fitting To Trans. (Rear); Service Item

## A63040

Jeep; Wrangler; 1993-1987; 4-Cyl. 2.5 Eng.; Connector From Rad; 2 Reqd  
 Jeep; Wrangler; 1993-1991; 6-Cyl. 4.0 Eng.; Connector From Rad; 2 Reqd  
 Jeep; Wrangler; 1990-1987; 6-Cyl. 4.2 Eng.; Connector From Rad; 2 Reqd

## A63041

Jeep; Grand Wagoneer; 1991-1987; V-8 5.9 Eng.; Connector From Rad; 2 Reqd  
 Jeep; J Pickup; 1987; 6-Cyl. 4.2 Eng.; Connector From Rad; 2 Reqd  
 Jeep; J Pickup; 1988-1987; V-8 5.9 Eng.; Connector From Rad; 2 Reqd

## A63042

Chry; Fifth Ave.; 1989-1984; V-8 5.2 Eng.; Inlet Fitting To Trans.  
 Chry; Fifth Ave.; 1989-1984; V-8 5.2 Eng.; Outlet Fitting To Trans.  
 Dodge; B Van; 1989-1988; V-6 3.9 Eng.; Inlet Fitting To Trans.  
 Dodge; B Van; 1989-1988; V-6 3.9 Eng.; Outlet Fitting To Trans.  
 Dodge; B Van; 1989-1984; V-8 5.2 Eng.; Inlet Fitting To Trans.  
 Dodge; B Van; 1989-1984; V-8 5.2 Eng.; Outlet Fitting To Trans.  
 Dodge; B Van; 1989-1984; V-8 5.9 Eng.; Inlet Fitting To Trans.  
 Dodge; B Van; 1989-1984; V-8 5.9 Eng.; Outlet Fitting To Trans.  
 Dodge; D & W Pickup; 1987-1982; 6-Cyl. 3.7 Eng.; Inlet Fitting To Trans.  
 Dodge; D & W Pickup; 1987-1982; 6-Cyl. 3.7 Eng.; Outlet Fitting To Trans.  
 Dodge; D & W Pickup; 1989-1988; V-6 3.9 Eng.; Inlet Fitting To Trans.  
 Dodge; D & W Pickup; 1989-1988; V-6 3.9 Eng.; Outlet Fitting To Trans.  
 Dodge; D & W Pickup; 1989-1982; V-8 5.2 Eng.; Inlet Fitting To Trans.  
 Dodge; D & W Pickup; 1989-1982; V-8 5.2 Eng.; Outlet Fitting To Trans.  
 Dodge; D & W Pickup; 1989-1982; V-8 5.9 Eng.; Inlet Fitting To Trans.  
 Dodge; D & W Pickup; 1989-1982; V-8 5.9 Eng.; Outlet Fitting To Trans.  
 Dodge; Dakota; 1989-1987; V-6 3.9 Eng.; Inlet Fitting To Trans.  
 Dodge; Dakota; 1989-1987; V-6 3.9 Eng.; Outlet Fitting To Trans.  
 Dodge; Dakota; 1989; V-8 5.2 Eng.; Inlet Fitting To Trans.  
 Dodge; Dakota; 1989; V-8 5.2 Eng.; Outlet Fitting To Trans.  
 Dodge; Diplomat; 1989-1984; V-8 5.2 Eng.; Inlet Fitting To Trans.  
 Dodge; Diplomat; 1989-1984; V-8 5.2 Eng.; Outlet Fitting To Trans.  
 Dodge; Ramcharger; 1989-1984; V-8 5.2 Eng.; Inlet Fitting To Trans.  
 Dodge; Ramcharger; 1989-1984; V-8 5.2 Eng.; Outlet Fitting To Trans.  
 Dodge; Ramcharger; 1989-1984; V-8 5.9 Eng.; Inlet Fitting To Trans.  
 Dodge; Ramcharger; 1989-1984; V-8 5.9 Eng.; Outlet Fitting To Trans.  
 Ply; Gran Fury; 1989-1984; V-8 5.2 Eng.; Inlet Fitting To Trans.  
 Ply; Gran Fury; 1989-1984; V-8 5.2 Eng.; Outlet Fitting To Trans.

## A63047

Ford; Bronco; 1992-1991; 6-Cyl. 4.9 Eng.; Tube Nut From Rad; 2 Reqd  
 Ford; Bronco; 1996-1991; V-8 5.0 Eng.; Tube Nut From Rad; 2 Reqd  
 Ford; Bronco; 1996-1991; V-8 5.8 Eng.; Tube Nut From Rad; 2 Reqd

## A63047 - Continued

Ford; Bronco Full Size; 1990-1988; 6-Cyl. 4.9 Eng.; Tube Nut From Rad; 2 Reqd  
 Ford; Bronco Full Size; 1990-1988; V-8 5.0 Eng.; Tube Nut From Rad; 2 Reqd  
 Ford; Bronco Full Size; 1990-1988; V-8 5.8 Eng.; Tube Nut From Rad; 2 Reqd  
 Ford; Country Squire; 1991-1988; V-8 5.0 Eng.; Tube Nut From Rad; 2 Reqd  
 Ford; Crown Victoria; 1995-1992; V-8 4.6 Eng.; Tube Nut From Rad; As Reqd  
 Ford; E Van; 1996-1988; 6-Cyl. 4.9 Eng.; Tube Nut From Rad; 2 Reqd  
 Ford; E Van; 1996-1988; V-8 5.0 Eng.; Tube Nut From Rad; 2 Reqd  
 Ford; E Van; 1996-1988; V-8 5.8 Eng.; Tube Nut From Rad; 2 Reqd  
 Ford; E Van; 1996-1988; V-8 7.3 Diesel Eng.; Tube Nut From Rad; 2 Reqd  
 Ford; E Van; 1996-1988; V-8 7.5 Eng.; Tube Nut From Rad; 2 Reqd  
 Ford; Escort; 1990-1988; 4-Cyl. 1.9 Eng.; Tube Nut From Rad; W/AOD Trans; 2 Reqd  
 Ford; F Pickup; 1996-1990; 6-Cyl. 4.9 Eng.; Tube Nut From Rad; 2 Reqd  
 Ford; F Pickup; 1996-1990; V-8 5.0 Eng.; Tube Nut From Rad; 2 Reqd  
 Ford; F Pickup; 1996-1990; V-8 5.8 Eng.; Tube Nut From Rad; 2 Reqd  
 Ford; F Pickup; 1996-1990; V-8 7.3 Diesel Eng.; Tube Nut From Rad; 2 Reqd  
 Ford; F Pickup; 1996-1990; V-8 7.5 Eng.; Tube Nut From Rad; 2 Reqd  
 Ford; Ltd Crown Victoria; 1991-1988; V-8 5.0 Eng.; Tube Nut From Rad; 2 Reqd  
 Ford; Ltd Crown Victoria; 1991-1988; V-8 5.8 Eng.; Tube Nut From Rad; 2 Reqd  
 Ford; Mustang; 1993-1988; 4-Cyl. 2.3 Eng.; Tube Nut From Rad; W/5/16" Tubing; 2 Reqd  
 Ford; Mustang; 1996-1994; V-6 3.8 Eng.; Tube Nut From Rad; 2 Reqd  
 Ford; Mustang; 1995-1994; V-8 5.0 Eng.; Tube Nut From Rad; 2 Reqd  
 Ford; Mustang; 1993-1989; V-8 5.0 Eng.; Tube Nut From Rad; W/5/16" Tubing; 2 Reqd  
 Ford; Mustang; 1995; V-8 5.8 Eng.; Tube Nut From Rad; 2 Reqd  
 Ford; Taurus; 1991-1986; 4-Cyl. 2.5 Eng.; Tube Nut From Rad; Service Item; 2 Reqd  
 Ford; Taurus; 1989-1986; V-6 3.0 Eng.; Tube Nut From Rad; Service Item; 2 Reqd  
 Ford; Taurus; 1989-1988; V-6 3.8 Eng.; Tube Nut From Rad; Service Item; 2 Reqd  
 Ford; Thunderbird; 1988; 4-Cyl. 2.3 Eng.; Tube Nut From Rad; W/4-Spd AT; 2 Reqd  
 Ford; Thunderbird; 1997-1996; V-6 3.8 Eng.; Tube Nut From Rad; 2 Reqd  
 Ford; Thunderbird; 1995-1990; V-6 3.8 Eng.; Tube Nut From Rad; W/Schgr; 2 Reqd  
 Ford; Thunderbird; 1989; V-6 3.8 Eng.; Tube Nut From Rad; 2 Reqd  
 Ford; Thunderbird; 1988; V-6 3.8 Eng.; Tube Nut From Rad; W/4-Spd AT; 2 Reqd  
 Ford; Thunderbird; 1997-1996; V-8 4.6 Eng.; Tube Nut From Rad; 2 Reqd  
 Ford; Thunderbird; 1988; V-8 5.0 Eng.; Tube Nut From Rad; W/4-Spd AT; 2 Reqd  
 Linc; Continental; 1989-1988; V-6 3.8 Eng.; Tube Nut From Rad; 2 Reqd  
 Linc; Mark VII; 1992-1988; V-8 5.0 Eng.; Tube Nut From Rad; 2 Reqd  
 Linc; Mark VIII; 1995-1993; V-8 4.6 Eng.; Tube Nut From Rad; 2 Reqd  
 Linc; Town Car; 1995-1991; V-8 4.6 Eng.; Tube Nut From Rad; 2 Reqd  
 Linc; Town Car; 1990-1988; V-8 5.0 Eng.; Tube Nut From Rad; 2 Reqd  
 Merc; Colony Park; 1991-1988; V-8 5.0 Eng.; Tube Nut From Rad; 2 Reqd  
 Merc; Cougar; 1997-1996; V-6 3.8 Eng.; Tube Nut From Rad; 2 Reqd  
 Merc; Cougar; 1990; V-6 3.8 Eng.; Tube Nut From Rad; W/Schgr; 2 Reqd  
 Merc; Cougar; 1989; V-6 3.8 Eng.; Tube Nut From Rad; 2 Reqd  
 Merc; Cougar; 1988; V-6 3.8 Eng.; Tube Nut From Rad; W/4-Spd AT; 2 Reqd  
 Merc; Cougar; 1997-1996; V-8 4.6 Eng.; Tube Nut From Rad; 2 Reqd  
 Merc; Cougar; 1988; V-8 5.0 Eng.; Tube Nut From Rad; W/4-Spd AT; 2 Reqd  
 Merc; Grand Marquis; 1995-1992; V-8 4.6 Eng.; Tube Nut From Rad; As Reqd  
 Merc; Grand Marquis; 1991-1989; V-8 5.0 Eng.; Tube Nut From Rad; As Reqd  
 Merc; Grand Marquis; 1988; V-8 5.0 Eng.; Tube Nut From Rad; 2 Reqd  
 Merc; Grand Marquis; 1989; V-8 5.8 (Canada) Eng.; Tube Nut From Rad; As Reqd  
 Merc; Grand Marquis; 1988; V-8 5.8 (Canada) Eng.; Tube Nut From Rad; 2 Reqd  
 Merc; Sable; 1986; 4-Cyl. 2.5 Eng.; Tube Nut From Rad; Service Item; 2 Reqd  
 Merc; Sable; 1989-1986; V-6 3.0 Eng.; Tube Nut From Rad; Service Item; 2 Reqd  
 Merc; Sable; 1989-1988; V-6 3.8 Eng.; Tube Nut From Rad; Service Item; 2 Reqd  
 Merc; Tracer; 1989-1988; 4-Cyl. 1.6 Eng.; Tube Nut From Rad; W/AOD Trans; 2 Reqd

# Numerical Listing - Oil Cooler Assemblies & End Fittings

## A63049

Ford; Country Squire; 1988; V-8 5.0 Eng.; Inlet Fitting To Trans.; 4-17 & Older  
 Ford; Country Squire; 1988; V-8 5.0 Eng.; Outlet Fitting To Trans.; 4-17 & Older  
 Ford; Escort; 1990-1988; 4-Cyl. 1.9 Eng.; Inlet Fitting To Trans.; W/Fact Fitting  
 Ford; Escort; 1990-1988; 4-Cyl. 1.9 Eng.; Outlet Fitting To Trans.; W/Fact Fitting  
 Ford; Ltd Crown Victoria; 1988; V-8 5.0 Eng.; Inlet Fitting To Trans.; 4-17 & Older  
 Ford; Ltd Crown Victoria; 1988; V-8 5.0 Eng.; Outlet Fitting To Trans.; 4-17 & Older  
 Ford; Ltd Crown Victoria; 1988; V-8 5.8 Eng.; Inlet Fitting To Trans.; 4-17 & Older  
 Ford; Ltd Crown Victoria; 1988; V-8 5.8 Eng.; Outlet Fitting To Trans.; 4-17 & Older  
 Ford; Mustang; 1988; 4-Cyl. 2.3 Eng.; Inlet Fitting To Trans.; W/AOD Trans.; 4-17 & Older  
 Ford; Mustang; 1988; 4-Cyl. 2.3 Eng.; Outlet Fitting To Trans.; W/AOD Trans.; 4-17 & Older  
 Ford; Taurus; 1991-1986; 4-Cyl. 2.5 Eng.; Inlet Fitting To Trans.; W/Fact Fitting  
 Ford; Taurus; 1991-1986; 4-Cyl. 2.5 Eng.; Outlet Fitting To Trans.; W/Fact Fitting  
 Ford; Taurus; 1995-1990; V-6 3.0 Eng.; Inlet Fitting To Trans.  
 Ford; Taurus; 1995-1990; V-6 3.0 Eng.; Outlet Fitting To Trans.  
 Ford; Taurus; 1989-1986; V-6 3.0 Eng.; Inlet Fitting To Trans.; W/Fact Fitting  
 Ford; Taurus; 1989-1986; V-6 3.0 Eng.; Outlet Fitting To Trans.; W/Fact Fitting  
 Ford; Taurus; 1995-1993; V-6 3.2 Eng.; Inlet Fitting To Trans.  
 Ford; Taurus; 1995-1993; V-6 3.2 Eng.; Outlet Fitting To Trans.  
 Ford; Taurus; 1995-1990; V-6 3.8 Eng.; Inlet Fitting To Trans.  
 Ford; Taurus; 1995-1990; V-6 3.8 Eng.; Outlet Fitting To Trans.  
 Ford; Taurus; 1989-1988; V-6 3.8 Eng.; Inlet Fitting To Trans.; W/Fact Fitting  
 Ford; Taurus; 1989-1988; V-6 3.8 Eng.; Outlet Fitting To Trans.; W/Fact Fitting  
 Ford; Tempo; 1994-1988; 4-Cyl. 2.3 Eng.; Inlet Fitting To Trans.  
 Ford; Tempo; 1994-1988; 4-Cyl. 2.3 Eng.; Outlet Fitting To Trans.  
 Ford; Tempo; 1994-1992; V-6 3.0 Eng.; Inlet Fitting To Trans.  
 Ford; Tempo; 1994-1992; V-6 3.0 Eng.; Outlet Fitting To Trans.  
 Ford; Thunderbird; 1988; 4-Cyl. 2.3 Eng.; Inlet Fitting To Trans.; 4-17 & Older  
 Ford; Thunderbird; 1988; 4-Cyl. 2.3 Eng.; Outlet Fitting To Trans.; 4-17 & Older  
 Ford; Thunderbird; 1988; V-6 3.8 Eng.; Inlet Fitting To Trans.; 4-17 & Older  
 Ford; Thunderbird; 1988; V-6 3.8 Eng.; Outlet Fitting To Trans.; 4-17 & Older  
 Ford; Thunderbird; 1988; V-8 5.0 Eng.; Inlet Fitting To Trans.; 4-17 & Older  
 Ford; Thunderbird; 1988; V-8 5.0 Eng.; Outlet Fitting To Trans.; 4-17 & Older  
 Ford; Windstar; 1998-1995; V-6 3.0 Eng.; Inlet Fitting To Trans.  
 Ford; Windstar; 1998-1995; V-6 3.0 Eng.; Outlet Fitting To Trans.  
 Ford; Windstar; 1998-1995; V-6 3.8 Eng.; Inlet Fitting To Trans.  
 Ford; Windstar; 1998-1995; V-6 3.8 Eng.; Outlet Fitting To Trans.  
 Linc; Continental; 1994-1990; V-6 3.8 Eng.; Connector From Rad; 2 Reqd  
 Linc; Continental; 1994-1990; V-6 3.8 Eng.; Inlet Fitting To Trans.  
 Linc; Continental; 1994-1990; V-6 3.8 Eng.; Outlet Fitting To Trans.  
 Linc; Continental; 1988; V-6 3.8 Eng.; Inlet Fitting To Trans.; W/Quick Connect Fitting; W/Fact Fitting  
 Linc; Continental; 1988; V-6 3.8 Eng.; Outlet Fitting To Trans.; W/Quick Connect Fitting; W/Fact Fitting  
 Linc; Mark VII; 1988; V-8 5.0 Eng.; Inlet Fitting To Trans.; W/Quick Connect Fitting; W/Fact Fitting  
 Linc; Mark VII; 1988; V-8 5.0 Eng.; Outlet Fitting To Trans.; W/Quick Connect Fitting; W/Fact Fitting  
 Linc; Town Car; 1988; V-8 5.0 Eng.; Inlet Fitting To Trans.; 4-17 & Older  
 Linc; Town Car; 1988; V-8 5.0 Eng.; Outlet Fitting To Trans.; 4-17 & Older  
 Merc; Colony Park; 1988; V-8 5.0 Eng.; Inlet Fitting To Trans.; 4-17 & Older  
 Merc; Colony Park; 1988; V-8 5.0 Eng.; Outlet Fitting To Trans.; 4-17 & Older  
 Merc; Cougar; 1988; V-6 3.8 Eng.; Inlet Fitting To Trans.; 4-17 & Older  
 Merc; Cougar; 1988; V-6 3.8 Eng.; Outlet Fitting To Trans.; 4-17 & Older  
 Merc; Cougar; 1988; V-8 5.0 Eng.; Inlet Fitting To Trans.; 4-17 & Older  
 Merc; Cougar; 1988; V-8 5.0 Eng.; Outlet Fitting To Trans.; 4-17 & Older  
 Merc; Grand Marquis; 1988; V-8 5.0 Eng.; Inlet Fitting To Trans.; 4-17 & Older  
 Merc; Grand Marquis; 1988; V-8 5.0 Eng.; Outlet Fitting To Trans.; 4-17 & Older

## A63049 - Continued

Merc; Grand Marquis; 1988; V-8 5.8 (Canada) Eng.; Inlet Fitting To Trans.; 4-17 & Older  
 Merc; Grand Marquis; 1988; V-8 5.8 (Canada) Eng.; Outlet Fitting To Trans.; 4-17 & Older  
 Merc; Sable; 1986; 4-Cyl. 2.5 Eng.; Inlet Fitting To Trans.; W/Fact Fitting  
 Merc; Sable; 1986; 4-Cyl. 2.5 Eng.; Outlet Fitting To Trans.; W/Fact Fitting  
 Merc; Sable; 1995-1990; V-6 3.0 Eng.; Inlet Fitting To Trans.  
 Merc; Sable; 1995-1990; V-6 3.0 Eng.; Outlet Fitting To Trans.  
 Merc; Sable; 1989-1986; V-6 3.0 Eng.; Inlet Fitting To Trans.; W/Fact Fitting  
 Merc; Sable; 1989-1986; V-6 3.0 Eng.; Outlet Fitting To Trans.; W/Fact Fitting  
 Merc; Sable; 1995-1990; V-6 3.8 Eng.; Inlet Fitting To Trans.  
 Merc; Sable; 1995-1990; V-6 3.8 Eng.; Outlet Fitting To Trans.  
 Merc; Sable; 1989-1988; V-6 3.8 Eng.; Inlet Fitting To Trans.; W/Fact Fitting  
 Merc; Sable; 1989-1988; V-6 3.8 Eng.; Outlet Fitting To Trans.; W/Fact Fitting  
 Merc; Topaz; 1994-1988; 4-Cyl. 2.3 Eng.; Inlet Fitting To Trans.  
 Merc; Topaz; 1994-1988; 4-Cyl. 2.3 Eng.; Outlet Fitting To Trans.  
 Merc; Topaz; 1994-1992; V-6 3.0 Eng.; Inlet Fitting To Trans.  
 Merc; Topaz; 1994-1992; V-6 3.0 Eng.; Outlet Fitting To Trans.  
 Merc; Tracer; 1989-1988; 4-Cyl. 1.6 Eng.; Inlet Fitting To Trans.; W/Fact Fitting  
 Merc; Tracer; 1989-1988; 4-Cyl. 1.6 Eng.; Outlet Fitting To Trans.; W/Fact Fitting

## A63050

Ford; Bronco; 1992-1991; 6-Cyl. 4.9 Eng.; Connector From Rad; 2 Reqd  
 Ford; Bronco; 1996-1991; V-8 5.0 Eng.; Connector From Rad; 2 Reqd  
 Ford; Bronco; 1996-1991; V-8 5.8 Eng.; Connector From Rad; 2 Reqd  
 Ford; Bronco Full Size; 1990-1988; 6-Cyl. 4.9 Eng.; Connector From Rad; 2 Reqd  
 Ford; Bronco Full Size; 1990-1988; V-8 5.0 Eng.; Connector From Rad; 2 Reqd  
 Ford; Bronco Full Size; 1990-1988; V-8 5.8 Eng.; Connector From Rad; 2 Reqd  
 Ford; Country Squire; 1991-1988; V-8 5.0 Eng.; Connector From Rad; 2 Reqd  
 Ford; Crown Victoria; 1999-1992; V-8 4.6 Eng.; Connector From Rad; As Reqd  
 Ford; E Van; 1996-1988; 6-Cyl. 4.9 Eng.; Connector From Rad; W/1/4" Male Pipe Thread; 2 Reqd  
 Ford; E Van; 2003-1999; V-6 4.2 Eng.; Connector From Rad; W/1/4" Male Pipe Thread; As Reqd  
 Ford; E Van; 1998-1997; V-6 4.2 Eng.; Connector From Rad; W/1/4" Male Pipe Thread; 2 Reqd  
 Ford; E Van; 2003-1999; V-8 4.6 Eng.; Connector From Rad; W/1/4" Male Pipe Thread; As Reqd  
 Ford; E Van; 1998-1997; V-8 4.6 Eng.; Connector From Rad; W/1/4" Male Pipe Thread; 2 Reqd  
 Ford; E Van; 1996-1988; V-8 5.0 Eng.; Connector From Rad; W/1/4" Male Pipe Thread; 2 Reqd  
 Ford; E Van; 2003-1997; V-8 5.4 Eng.; Connector From Rad; W/1/4" Male Pipe Thread; 2 Reqd  
 Ford; E Van; 1996-1988; V-8 5.8 Eng.; Connector From Rad; W/1/4" Male Pipe Thread; 2 Reqd  
 Ford; E Van; 1998-1988; V-8 7.3 Diesel Eng.; Connector From Rad; W/1/4" Male Pipe Thread; 2 Reqd  
 Ford; E Van; 1996-1988; V-8 7.5 Eng.; Connector From Rad; W/1/4" Male Pipe Thread; 2 Reqd  
 Ford; E Van; 1998-1997; V-10 6.8 Eng.; Connector From Rad; W/1/4" Male Pipe Thread; 2 Reqd  
 Ford; Escort; 1990-1988; 4-Cyl. 1.9 Eng.; Connector From Rad; W/AOD Trans.; 2 Reqd  
 Ford; Excursion; 2001; V-8 7.3 Diesel Eng.; Connector From Rad; W/1/4" Male Pipe Thread; 2 Reqd  
 Ford; F Pickup; 1996-1990; 6-Cyl. 4.9 Eng.; Connector From Rad; 2 Reqd  
 Ford; F Pickup; 1997; V-6 4.2 Eng.; Connector From Rad; W/1/4" Male Pipe Thread; 2 Reqd  
 Ford; F Pickup; 1997; V-8 4.6 Eng.; Connector From Rad; W/1/4" Male Pipe Thread; 2 Reqd  
 Ford; F Pickup; 1996-1990; V-8 5.0 Eng.; Connector From Rad; 2 Reqd  
 Ford; F Pickup; 1996-1990; V-8 5.8 Eng.; Connector From Rad; 2 Reqd  
 Ford; F Pickup; 1996-1990; V-8 7.3 Diesel Eng.; Connector From Rad; 2 Reqd  
 Ford; F Pickup; 1996-1990; V-8 7.5 Eng.; Connector From Rad; 2 Reqd  
 Ford; Ltd Crown Victoria; 1991-1988; V-8 5.0 Eng.; Connector From Rad; 2 Reqd  
 Ford; Ltd Crown Victoria; 1991-1988; V-8 5.8 Eng.; Connector From Rad; 2 Reqd  
 Ford; Mustang; 1993-1989; 4-Cyl. 2.3 Eng.; Connector From Rad; W/5/16" Tubing; 2 Reqd

# Numerical Listing - Oil Cooler Assemblies & End Fittings

## A63050 - Continued

Ford; Mustang; 1988; 4-Cyl. 2.3 Eng.; Connector From Rad; 2 Reqd  
 Ford; Mustang; 2002-1994; V-6 3.8 Eng.; Connector From Rad; 2 Reqd  
 Ford; Mustang; 2002-1997; V-8 4.6 Eng.; Connector From Rad; 2 Reqd  
 Ford; Mustang; 1995-1994; V-8 5.0 Eng.; Connector From Rad; 2 Reqd  
 Ford; Mustang; 1993-1989; V-8 5.0 Eng.; Connector From Rad; W/5/16" Tubing; 2 Reqd  
 Ford; Mustang; 1995; V-8 5.8 Eng.; Connector From Rad; 2 Reqd  
 Ford; Super Duty Van; 2003-2001; V-6 4.2 Eng.; Connector From Rad; W/1/4" Male Pipe Thread; As Reqd  
 Ford; Super Duty Van; 2003; V-8 4.6 Eng.; Connector From Rad; W/1/4" Male Pipe Thread; As Reqd  
 Ford; Super Duty Van; 2003-1997; V-8 5.4 Eng.; Connector From Rad; W/1/4" Male Pipe Thread; 2 Reqd  
 Ford; Super Duty Van; 2003-1997; V-8 7.3 Diesel Eng.; Connector From Rad; W/1/4" Male Pipe Thread; 2 Reqd  
 Ford; Super Duty Van; 2003-1997; V-10 6.8 Eng.; Connector From Rad; W/1/4" Male Pipe Thread; 2 Reqd  
 Ford; Taurus; 1991-1986; 4-Cyl. 2.5 Eng.; Connector From Rad; 2 Reqd  
 Ford; Taurus; 1995-1986; V-6 3.0 Eng.; Connector From Rad; 2 Reqd  
 Ford; Taurus; 1995-1988; V-6 3.8 Eng.; Connector From Rad; 2 Reqd  
 Ford; Thunderbird; 1988; 4-Cyl. 2.3 Eng.; Connector From Rad; 2 Reqd  
 Ford; Thunderbird; 1997-1988; V-6 3.8 Eng.; Connector From Rad; 2 Reqd  
 Ford; Thunderbird; 1997-1994; V-8 4.6 Eng.; Connector From Rad; 2 Reqd  
 Ford; Thunderbird; 1993-1991; V-8 5.0 Eng.; Connector From Rad; 2 Reqd  
 Ford; Thunderbird; 1988; V-8 5.0 Eng.; Connector From Rad; 2 Reqd  
 Linc; Continental; 1989-1988; V-6 3.8 Eng.; Connector From Rad; 2 Reqd  
 Linc; Continental; 2002-1995; V-8 4.6 Eng.; Connector From Rad; 2 Reqd  
 Linc; Mark VII; 1992-1988; V-8 5.0 Eng.; Connector From Rad; 2 Reqd  
 Linc; Mark VIII; 1998-1996; V-8 4.6 Eng.; Connector From Rad; 2 Reqd  
 Linc; Town Car; 1990-1988; V-8 5.0 Eng.; Connector From Rad; 2 Reqd  
 Merc; Colony Park; 1991-1988; V-8 5.0 Eng.; Connector From Rad; 2 Reqd  
 Merc; Cougar; 1997-1988; V-6 3.8 Eng.; Connector From Rad; 2 Reqd  
 Merc; Cougar; 1997-1994; V-8 4.6 Eng.; Connector From Rad; 2 Reqd  
 Merc; Cougar; 1993-1991; V-8 5.0 Eng.; Connector From Rad; 2 Reqd  
 Merc; Cougar; 1988; V-8 5.0 Eng.; Connector From Rad; 2 Reqd  
 Merc; Grand Marquis; 1999-1992; V-8 4.6 Eng.; Connector From Rad; As Reqd  
 Merc; Grand Marquis; 1991-1989; V-8 5.0 Eng.; Connector From Rad; As Reqd  
 Merc; Grand Marquis; 1988; V-8 5.0 Eng.; Connector From Rad; 2 Reqd  
 Merc; Grand Marquis; 1989; V-8 5.8 (Canada) Eng.; Connector From Rad; As Reqd  
 Merc; Grand Marquis; 1988; V-8 5.8 (Canada) Eng.; Connector From Rad; 2 Reqd  
 Merc; Sable; 1986; 4-Cyl. 2.5 Eng.; Connector From Rad; 2 Reqd  
 Merc; Sable; 1995-1986; V-6 3.0 Eng.; Connector From Rad; 2 Reqd  
 Merc; Sable; 1995-1988; V-6 3.8 Eng.; Connector From Rad; 2 Reqd  
 Merc; Tracer; 1989-1988; 4-Cyl. 1.6 Eng.; Connector From Rad; W/AOD Trans; 2 Reqd

## A63063

Cad; Deville; 2003-2001; V-8 4.6 Eng.; Inlet Fitting To Trans. (Upper); W/Quick Connect Fitting  
 Cad; Eldorado; 2002-2001; V-8 4.6 Eng.; Inlet Fitting To Trans. (Upper); W/Quick Connect Fitting  
 Cad; Seville; 2003-2001; V-8 4.6 Eng.; Inlet Fitting To Trans. (Upper); W/Quick Connect Fitting  
 Olds; Aurora; 2003-2001; V-8 4.0 Eng.; Inlet Fitting To Trans. (Upper); W/Quick Connect Fitting  
 Olds; Aurora; 1999-1995; V-8 4.0 Eng.; Inlet Fitting To Trans. (Upper); W/Quick Connect Fitting

## A63064

Buick; Century; 2003-2000; V-6 3.1 Eng.; Outlet Fitting To Trans. (Lower)  
 Buick; Lesabre; 2003-2000; V-6 3.8 Eng.; Outlet Fitting To Trans. (Lower)  
 Buick; Park Ave.; 2004; V-6 3.8 Eng.; Inlet Fitting To Trans. (Upper)  
 Buick; Park Ave.; 2003-2000; V-6 3.8 Eng.; Outlet Fitting To Trans. (Lower)  
 Buick; Regal; 2003-2000; V-6 3.8 Eng.; Outlet Fitting To Trans. (Lower)  
 Buick; Rendezvous; 2003-2002; V-6 3.4 Eng.; Outlet Fitting To Trans. (Lower)  
 Chev; Impala; 2003-2000; V-6 3.4 Eng.; Outlet Fitting To Trans. (Lower)  
 Chev; Impala; 2003-2000; V-6 3.8 Eng.; Outlet Fitting To Trans. (Lower)  
 Chev; Lumina; 2001-2000; V-6 3.1 Eng.; Outlet Fitting To Trans. (Lower)  
 Chev; Monte Carlo; 2003-2000; V-6 3.4 Eng.; Outlet Fitting To Trans. (Lower)  
 Chev; Monte Carlo; 2003-2000; V-6 3.8 Eng.; Outlet Fitting To Trans. (Lower)

## A63064 - Continued

Chev; Venture; 2003-2000; V-6 3.4 Eng.; Connector From Rad; 2 Reqd  
 Olds; Aurora; 2002-2001; V-6 3.5 Eng.; Outlet Fitting To Trans. (Lower)  
 Olds; Intrigue; 2002-2000; V-6 3.5 Eng.; Outlet Fitting To Trans. (Lower)  
 Olds; Silhouette; 2003-2000; V-6 3.4 Eng.; Connector From Rad; 2 Reqd  
 Pont; Aztek; 2003-2001; V-6 3.4 Eng.; Outlet Fitting To Trans. (Lower)  
 Pont; Bonneville; 2003-2000; V-6 3.8 Eng.; Outlet Fitting To Trans. (Lower)  
 Pont; Grand Prix; 2003-2000; V-6 3.1 Eng.; Outlet Fitting To Trans. (Lower)  
 Pont; Grand Prix; 2003-2000; V-6 3.8 Eng.; Outlet Fitting To Trans. (Lower)  
 Pont; Montana; 2003-2001; V-6 3.4 Eng.; Outlet Fitting To Trans. (Lower)  
 Pont; Montana; 2000; V-6 3.4 Eng.; Connector From Rad; 2 Reqd

## A63065

Buick; Century; 2003-2000; V-6 3.1 Eng.; Connector From Rad; 2 Reqd  
 Buick; Regal; 2003-2000; V-6 3.8 Eng.; Connector From Rad; 2 Reqd  
 Cad; Deville; 2003-2001; V-8 4.6 Eng.; Connector From Rad (Upper)  
 Cad; Eldorado; 2002-2001; V-8 4.6 Eng.; Connector From Rad (Upper)  
 Cad; Seville; 2003-2001; V-8 4.6 Eng.; Connector From Rad (Upper)  
 Chev; Impala; 2003-2000; V-6 3.4 Eng.; Connector From Rad; 2 Reqd  
 Chev; Impala; 2003-2000; V-6 3.8 Eng.; Connector From Rad; 2 Reqd  
 Chev; Lumina; 2001-2000; V-6 3.1 Eng.; Connector From Rad; 2 Reqd  
 Chev; Monte Carlo; 2003-2000; V-6 3.4 Eng.; Connector From Rad; 2 Reqd  
 Chev; Monte Carlo; 2003-2000; V-6 3.8 Eng.; Connector From Rad; 2 Reqd  
 Chev; S Pickup; 2003; V-6 4.3 Eng.; Connector From Rad; 3-9 & Older; 2 Reqd  
 Chev; S Pickup; 2002; V-6 4.3 Eng.; Connector From Rad; 2 Reqd  
 Chev; SSR; 2003; V-8 5.3 Eng.; Connector From Rad; W/O Beveled Washer  
 GMC; Sonoma; 2003; V-6 4.3 Eng.; Connector From Rad; 3-9 & Older; 2 Reqd  
 GMC; Sonoma; 2002; V-6 4.3 Eng.; Connector From Rad; 2 Reqd  
 Olds; Aurora; 2002-2001; V-6 3.5 Eng.; Connector From Rad (Upper); 2 Reqd  
 Olds; Aurora; 2003-2001; V-8 4.0 Eng.; Connector From Rad (Upper)  
 Olds; Aurora; 1999-1995; V-8 4.0 Eng.; Connector From Rad (Upper)  
 Pont; Grand Prix; 2003-2000; V-6 3.1 Eng.; Connector From Rad; 2 Reqd  
 Pont; Grand Prix; 2003-2000; V-6 3.8 Eng.; Connector From Rad; 2 Reqd

## A63067

Chev; Silverado Pickup; 2003-2001; V-8 6.6 Diesel Eng.; Connector From Rad; 2 Reqd  
 GMC; Sierra Pickup; 2003-2001; V-8 6.6 Diesel Eng.; Connector From Rad; 2 Reqd

## A63068

Chev; Silverado Pickup; 2002-2001; V-8 6.6 Diesel Eng.; Connector From Aux. Cooler; 2 Reqd  
 GMC; Sierra Pickup; 2002-2001; V-8 6.6 Diesel Eng.; Connector From Aux. Cooler; 2 Reqd

## A63076

Ford; Taurus; 2003-1996; V-6 3.0 Eng.; Inlet Fitting To Trans.  
 Ford; Taurus; 2003-1996; V-6 3.0 Eng.; Outlet Fitting To Trans.  
 Ford; Taurus; 1999-1996; V-8 3.4 Eng.; Inlet Fitting To Trans.  
 Ford; Taurus; 1999-1996; V-8 3.4 Eng.; Outlet Fitting To Trans.  
 Ford; Windstar; 2000-1999; V-6 3.0 Eng.; Inlet Fitting To Trans.  
 Ford; Windstar; 2000-1999; V-6 3.0 Eng.; Outlet Fitting To Trans.  
 Ford; Windstar; 2003-1999; V-6 3.8 Eng.; Inlet Fitting To Trans.  
 Ford; Windstar; 2003-1999; V-6 3.8 Eng.; Outlet Fitting To Trans.  
 Linc; Continental; 2002-1995; V-8 4.6 Eng.; Inlet Fitting To Trans.  
 Linc; Continental; 2002-1995; V-8 4.6 Eng.; Outlet Fitting To Trans.  
 Merc; Sable; 2003-1996; V-6 3.0 Eng.; Inlet Fitting To Trans.  
 Merc; Sable; 2003-1996; V-6 3.0 Eng.; Outlet Fitting To Trans.

## A63087

Buick; Riviera; 1993-1991; V-6 3.8 Eng.; Aux. Cooler Outlet Hose Fitting (Upper)  
 Cad; Deville; 1995-1994; V-8 4.9 Eng.; Aux. Cooler Outlet Hose Fitting (Upper)  
 Cad; Eldorado; 1993-1991; V-8 4.9 Eng.; Aux. Cooler Outlet Hose Fitting (Upper)  
 Cad; Seville; 1993-1991; V-8 4.9 Eng.; Aux. Cooler Outlet Hose Fitting (Upper)  
 Olds; Toronado; 1992-1991; V-6 3.8 Eng.; Aux. Cooler Outlet Hose Fitting (Upper)



# Numerical Listing - Oil Cooler Assemblies & End Fittings

## A63089

Cad; Allante; 1993; V-8 4.6 Eng.; Inlet Fitting "O" Ring  
 Cad; Allante; 1993; V-8 4.6 Eng.; Outlet Fitting "O" Ring  
 Cad; Deville; 2003-1994; V-8 4.6 Eng.; Outlet Fitting "O" Ring (Lower)  
 Cad; Eldorado; 2002-1993; V-8 4.6 Eng.; Outlet Fitting "O" Ring (Lower)  
 Cad; Seville; 2003-1994; V-8 4.6 Eng.; Outlet Fitting "O" Ring (Lower)  
 Olds; Aurora; 2003-2001; V-8 4.0 Eng.; Outlet Fitting "O" Ring (Lower)  
 Olds; Aurora; 1999-1995; V-8 4.0 Eng.; Outlet Fitting "O" Ring (Lower)

## A63090

Cad; Deville; 2003-1994; V-8 4.6 Eng.; Inlet Fitting "O" Ring (Upper)  
 Cad; Eldorado; 2002-1993; V-8 4.6 Eng.; Inlet Fitting "O" Ring (Upper)  
 Cad; Seville; 2003-1994; V-8 4.6 Eng.; Inlet Fitting "O" Ring (Upper)  
 Ford; Aerostar; 1997-1987; V-6 3.0 Eng.; "O" Ring (Connector & Fitting);  
 As Reqd  
 Ford; Aerostar; 1997-1990; V-6 4.0 Eng.; "O" Ring (Connector & Fitting);  
 As Reqd  
 Ford; Bronco Compact; 1990-1988; V-6 2.9 Eng.; "O" Ring (Connector &  
 Fitting); As Reqd  
 Ford; Contour; 1997; 4-Cyl. 2.0 Eng.; "O" Ring (Fitting); 11-23 & Older; 2  
 Reqd  
 Ford; Contour; 1996-1995; 4-Cyl. 2.0 Eng.; "O" Ring (Fitting); 2 Reqd  
 Ford; Contour; 1997; V-6 2.5 Eng.; "O" Ring (Fitting); 11-23 & Older; 2  
 Reqd  
 Ford; Contour; 1996-1995; V-6 2.5 Eng.; "O" Ring (Fitting); 2 Reqd  
 Ford; Excursion; 2005-2000; V-8 5.4 Eng.; "O" Ring (Connector); As Reqd  
 Ford; Excursion; 2002; V-8 7.3 Diesel Eng.; "O" Ring (Connector); As  
 Reqd  
 Ford; Excursion; 2000; V-8 7.3 Diesel Eng.; "O" Ring (Connector); As  
 Reqd  
 Ford; Excursion; 2005-2000; V-10 6.8 Eng.; "O" Ring (Connector); As  
 Reqd  
 Ford; Expedition; 2002-1999; V-8 4.6 Eng.; "O" Ring (Connector & Fitting);  
 W/3/8" Tubing; As Reqd  
 Ford; Expedition; 2002-1997; V-8 5.4 Eng.; "O" Ring (Connector); As  
 Reqd  
 Ford; Explorer; 2002-1997; V-6 4.0 Eng.; "O" Ring (Connector & Fitting); 2  
 Reqd  
 Ford; Explorer; 1996-1991; V-6 4.0 Eng.; "O" Ring (Connector & Fitting);  
 As Reqd  
 Ford; Explorer; 2001-1996; V-8 5.0 Eng.; "O" Ring (Connector & Fitting); 2  
 Reqd  
 Ford; Explorer Sport Trac; 2002-2001; V-6 4.0 Eng.; "O" Ring (Connector  
 & Fitting); 2 Reqd  
 Ford; F Pickup; 2002; V-6 4.2 Eng.; "O" Ring (Connector & Fitting); As  
 Reqd  
 Ford; F Pickup; 2001-2000; V-6 4.2 Eng.; "O" Ring (Connector & Fitting);  
 W/3/8" Tubing; As Reqd  
 Ford; F Pickup; 1999-1998; V-6 4.2 Eng.; "O" Ring (Connector); As Reqd  
 Ford; F Pickup; 2002; V-8 4.6 Eng.; "O" Ring (Connector & Fitting); As  
 Reqd  
 Ford; F Pickup; 2001-2000; V-8 4.6 Eng.; "O" Ring (Connector & Fitting);  
 W/3/8" Tubing; As Reqd  
 Ford; F Pickup; 1999-1998; V-8 4.6 Eng.; "O" Ring (Connector); As Reqd  
 Ford; F Pickup; 2002-1997; V-8 5.4 Eng.; "O" Ring (Connector & Fitting);  
 W/3/8" Tubing; As Reqd  
 Ford; F Pickup; 1997; V-8 5.8 Eng.; "O" Ring (Connector & Fitting); As  
 Reqd  
 Ford; F Pickup; 1997; V-8 7.3 Diesel Eng.; "O" Ring (Connector & Fitting);  
 As Reqd  
 Ford; F Pickup; 1997; V-8 7.5 Eng.; "O" Ring (Connector & Fitting); As  
 Reqd  
 Ford; Probe; 1997-1993; 4-Cyl. 2.0 Eng.; "O" Ring (Fitting); 2 Reqd  
 Ford; Probe; 1997-1993; V-6 2.5 Eng.; "O" Ring (Fitting); 2 Reqd  
 Ford; Ranger; 1988; 4-Cyl. 2.0 Eng.; "O" Ring (Connector & Fitting); As  
 Reqd  
 Ford; Ranger; 2003-2001; 4-Cyl. 2.3 Eng.; "O" Ring (Connector & Fitting);  
 As Reqd  
 Ford; Ranger; 1997-1988; 4-Cyl. 2.3 Eng.; "O" Ring (Connector & Fitting);  
 As Reqd  
 Ford; Ranger; 2001-1998; 4-Cyl. 2.5 Eng.; "O" Ring (Connector & Fitting);  
 As Reqd  
 Ford; Ranger; 1992-1988; V-6 2.9 Eng.; "O" Ring (Connector & Fitting);  
 As Reqd  
 Ford; Ranger; 2003-1991; V-6 3.0 Eng.; "O" Ring (Connector & Fitting);  
 As Reqd  
 Ford; Ranger; 2003-1990; V-6 4.0 Eng.; "O" Ring (Connector & Fitting);  
 As Reqd  
 Ford; Super Duty Pickup; 2002-1999; V-8 5.4 Eng.; "O" Ring (Connector);  
 As Reqd  
 Ford; Super Duty Pickup; 2002-1999; V-8 7.3 Diesel Eng.; "O" Ring (Con-  
 nector); As Reqd  
 Ford; Super Duty Pickup; 1997; V-8 7.3 Diesel Eng.; "O" Ring (Connector  
 & Fitting); As Reqd

## A63090 - Continued

Ford; Super Duty Pickup; 2002-1999; V-10 6.8 Eng.; "O" Ring (Connec-  
 tor); As Reqd  
 Ford; Taurus; 1995-1993; V-6 3.2 Eng.; "O" Ring (Connector); 2 Reqd  
 Linc; Navigator; 2002-1998; V-8 5.4 Eng.; "O" Ring (Connector); As Reqd  
 Merc; Mountaineer; 2002-1998; V-6 4.0 Eng.; "O" Ring (Connector & Fit-  
 ting); 2 Reqd  
 Merc; Mountaineer; 2002; V-8 4.6 Eng.; "O" Ring (Connector & Fitting); 2  
 Reqd  
 Merc; Mountaineer; 2001-1997; V-8 5.0 Eng.; "O" Ring (Connector & Fit-  
 ting); 2 Reqd  
 Merc; Mystique; 1997; 4-Cyl. 2.0 Eng.; "O" Ring (Fitting); 11-23 & Older; 2  
 Reqd  
 Merc; Mystique; 1996-1995; 4-Cyl. 2.0 Eng.; "O" Ring (Fitting); 2 Reqd  
 Merc; Mystique; 1997; V-6 2.5 Eng.; "O" Ring (Fitting); 11-23 & Older; 2  
 Reqd  
 Merc; Mystique; 1996-1995; V-6 2.5 Eng.; "O" Ring (Fitting); 2 Reqd  
 Olds; Aurora; 2003-2001; V-8 4.0 Eng.; Inlet Fitting "O" Ring (Upper)  
 Olds; Aurora; 1999-1995; V-8 4.0 Eng.; Inlet Fitting "O" Ring (Upper)

## A63091

Chev; C&K Pickup; 1995-1993; V-8 5.7 Eng.; Connector "O" Ring; As  
 Reqd  
 Chev; C&K Pickup; 1995-1993; V-8 6.5 Diesel Eng.; Connector "O" Ring;  
 As Reqd  
 Chev; C&K Pickup; 1995-1993; V-8 7.4 Eng.; Connector "O" Ring; As  
 Reqd  
 Chev; Suburban; 1995-1993; V-8 5.7 Eng.; Connector "O" Ring; As Reqd  
 Chev; Suburban; 1995-1994; V-8 6.5 Diesel Eng.; Connector "O" Ring; As  
 Reqd  
 Chev; Suburban; 1995-1993; V-8 7.4 Eng.; Connector "O" Ring; As Reqd  
 Chev; Tahoe; 1995; V-8 5.7 Eng.; Connector "O" Ring; As Reqd  
 Chev; Tahoe; 1995; V-8 6.5 Diesel Eng.; Connector "O" Ring; As Reqd  
 GMC; C&K Pickup; 1995-1993; V-8 5.7 Eng.; Connector "O" Ring; As  
 Reqd  
 GMC; C&K Pickup; 1995-1993; V-8 6.5 Diesel Eng.; Connector "O" Ring;  
 As Reqd  
 GMC; C&K Pickup; 1995-1993; V-8 7.4 Eng.; Connector "O" Ring; As  
 Reqd  
 GMC; Suburban; 1995-1993; V-8 5.7 Eng.; Connector "O" Ring; As Reqd  
 GMC; Suburban; 1995-1994; V-8 6.5 Diesel Eng.; Connector "O" Ring; As  
 Reqd  
 GMC; Suburban; 1995-1993; V-8 7.4 Eng.; Connector "O" Ring; As Reqd  
 GMC; Yukon; 1995-1993; V-8 5.7 Eng.; Connector "O" Ring; As Reqd  
 GMC; Yukon; 1995-1994; V-8 6.5 Diesel Eng.; Connector "O" Ring; As  
 Reqd

## A63093

Chry; Imperial; 1993-1991; V-6 3.8 Eng.; "O" Ring From Cooler; 2 Reqd  
 Chry; Lebaron; 1990-1986; 4-Cyl. 2.2 Eng.; "O" Ring; 2 Reqd  
 Chry; Lebaron; 1990-1986; 4-Cyl. 2.5 Eng.; "O" Ring; 2 Reqd  
 Chry; Lebaron; 1992-1991; V-6 3.0 Eng.; "O" Ring From Water Cooled  
 Trans. Cooler; 2 Reqd  
 Chry; Lebaron; 1990; V-6 3.0 Eng.; "O" Ring; 2 Reqd  
 Chry; New Yorker; 1988-1986; 4-Cyl. 2.2 Eng.; "O" Ring From Water  
 Cooled Trans. Cooler; 2 Reqd  
 Chry; New Yorker; 1987-1986; 4-Cyl. 2.5 Eng.; "O" Ring From Water  
 Cooled Trans. Cooler; 2 Reqd  
 Chry; New Yorker; 1993; V-6 3.3 Eng.; "O" Ring From Cooler; 2 Reqd  
 Chry; New Yorker; 1992-1991; V-6 3.3 Eng.; "O" Ring; W/Water Cooled  
 Trans. Cooler; 2 Reqd  
 Chry; New Yorker; 1993; V-6 3.8 Eng.; "O" Ring From Cooler; 2 Reqd  
 Chry; New Yorker; 1992-1991; V-6 3.8 Eng.; "O" Ring; W/Water Cooled  
 Trans. Cooler; 2 Reqd  
 Chry; TC Maserati; 1990-1989; 4-Cyl. 2.2 Eng.; Cooler "O" Ring; 2 Reqd  
 Chry; TC Maserati; 1991-1990; V-6 3.0 Eng.; Cooler "O" Ring; 2 Reqd  
 Chry; Town & Country; 1988-1986; 4-Cyl. 2.2 Eng.; "O" Ring; W/Water  
 Cooled Trans. Cooler; 2 Reqd  
 Chry; Town & Country; 1988-1986; 4-Cyl. 2.5 Eng.; "O" Ring; W/Water  
 Cooled Trans. Cooler; 2 Reqd  
 Chry; Town & Country Van; 1993-1990; V-6 3.3 Eng.; "O" Ring; W/Water  
 Cooled Trans. Cooler; 2 Reqd  
 Chry; Town & Country Van; 1995-1994; V-6 3.8 Eng.; "O" Ring; W/Water  
 Cooled Trans. Cooler; 2 Reqd  
 Dodge; Aries; 1987-1986; 4-Cyl. 2.2 Eng.; "O" Ring From Aux. Cooler; 2  
 Reqd  
 Dodge; Aries; 1987-1986; 4-Cyl. 2.5 Eng.; "O" Ring From Aux. Cooler; 2  
 Reqd  
 Dodge; Aries America; 1989-1988; 4-Cyl. 2.2 Eng.; "O" Ring From Aux.  
 Cooler; 2 Reqd  
 Dodge; Aries America; 1989-1988; 4-Cyl. 2.5 Eng.; "O" Ring From Aux.  
 Cooler; 2 Reqd

# Numerical Listing - Oil Cooler Assemblies & End Fittings

## A63093 - Continued

Dodge; Caravan; 1995-1988; 4-Cyl. 2.5 Eng.; "O" Ring; W/Water Cooled Trans. Cooler; 2 Reqd

Dodge; Caravan; 1995-1994; V-6 3.0 Eng.; "O" Ring; W/Water Cooled Trans. Cooler

Dodge; Caravan; 1993-1988; V-6 3.0 Eng.; "O" Ring; W/Water Cooled Trans. Cooler; 2 Reqd

Dodge; Caravan; 1995-1990; V-6 3.3 Eng.; "O" Ring; W/Water Cooled Trans. Cooler; 2 Reqd

Dodge; Charger; 1987-1986; 4-Cyl. 2.2 Eng.; "O" Ring; W/Water Cooled Trans. Cooler; 2 Reqd

Dodge; Dakota; 1989-1987; V-6 3.9 Eng.; "O" Ring; W/Aux. Cooler; 2 Reqd

Dodge; Dakota; 1989; V-8 5.2 Eng.; "O" Ring; W/Aux. Cooler; 2 Reqd

Dodge; Daytona; 1992; 4-Cyl. 2.2 Eng.; "O" Ring; W/Water Cooled Trans. Cooler; 2 Reqd

Dodge; Daytona; 1990; 4-Cyl. 2.2 Eng.; "O" Ring; 2 Reqd

Dodge; Daytona; 1989-1988; 4-Cyl. 2.2 Eng.; "O" Ring From Aux. Cooler; 2 Reqd

Dodge; Daytona; 1987-1986; 4-Cyl. 2.2 Eng.; "O" Ring; W/Water Cooled Trans. Cooler; 2 Reqd

Dodge; Daytona; 1992-1991; 4-Cyl. 2.5 Eng.; "O" Ring; W/Water Cooled Trans. Cooler; 2 Reqd

Dodge; Daytona; 1990; 4-Cyl. 2.5 Eng.; "O" Ring; 2 Reqd

Dodge; Daytona; 1989-1988; 4-Cyl. 2.5 Eng.; "O" Ring From Aux. Cooler; 2 Reqd

Dodge; Daytona; 1987-1986; 4-Cyl. 2.5 Eng.; "O" Ring; W/Water Cooled Trans. Cooler; 2 Reqd

Dodge; Daytona; 1992-1991; V-6 3.0 Eng.; "O" Ring; W/Water Cooled Trans. Cooler; 2 Reqd

Dodge; Daytona; 1990; V-6 3.0 Eng.; "O" Ring; 2 Reqd

Dodge; Dynasty; 1992-1991; 4-Cyl. 2.5 Eng.; "O" Ring; W/Water Cooled Trans. Cooler; 2 Reqd

Dodge; Dynasty; 1993; V-6 3.0 Eng.; "O" Ring From Cooler; 2 Reqd

Dodge; Dynasty; 1992-1991; V-6 3.0 Eng.; "O" Ring; W/Water Cooled Trans. Cooler; 2 Reqd

Dodge; Dynasty; 1993; V-6 3.3 Eng.; "O" Ring From Cooler; 2 Reqd

Dodge; Dynasty; 1992-1991; V-6 3.3 Eng.; "O" Ring; W/Water Cooled Trans. Cooler; 2 Reqd

Dodge; Grand Caravan; 1989-1988; 4-Cyl. 2.5 Eng.; "O" Ring; W/Water Cooled Trans. Cooler; 2 Reqd

Dodge; Grand Caravan; 1995-1994; V-6 3.0 Eng.; "O" Ring; W/Water Cooled Trans. Cooler

Dodge; Grand Caravan; 1993-1992; V-6 3.0 Eng.; "O" Ring; W/Water Cooled Trans. Cooler; 2 Reqd

Dodge; Grand Caravan; 1989; V-6 3.0 Eng.; "O" Ring; W/Water Cooled Trans. Cooler; 2 Reqd

Dodge; Grand Caravan; 1995-1990; V-6 3.3 Eng.; "O" Ring; W/Water Cooled Trans. Cooler; 2 Reqd

Dodge; Grand Caravan; 1995-1994; V-6 3.8 Eng.; "O" Ring; W/Water Cooled Trans. Cooler; 2 Reqd

Dodge; Lancer; 1989-1986; 4-Cyl. 2.2 Eng.; "O" Ring From Aux. Cooler; 2 Reqd

Dodge; Lancer; 1989-1986; 4-Cyl. 2.5 Eng.; "O" Ring From Aux. Cooler; 2 Reqd

Dodge; Mini Ram Van; 1988; 4-Cyl. 2.5 Eng.; "O" Ring; W/Water Cooled Trans. Cooler; 2 Reqd

Dodge; Omni; 1990-1987; 4-Cyl. 2.2 Eng.; "O" Ring; W/Water Cooled Trans. Cooler; 2 Reqd

Dodge; Shadow; 1991-1988; 4-Cyl. 2.2 Eng.; "O" Ring; W/O Water Cooled Trans. Cooler; 2 Reqd

Dodge; Shadow; 1987; 4-Cyl. 2.2 Eng.; "O" Ring; W/Water Cooled Trans. Cooler; 2 Reqd

Dodge; Shadow; 1991-1988; 4-Cyl. 2.5 Eng.; "O" Ring; W/O Water Cooled Trans. Cooler; 2 Reqd

Dodge; Spirit; 1990-1989; 4-Cyl. 2.5 Eng.; "O" Ring; W/Water Cooled Trans. Cooler; 2 Reqd

Dodge; Spirit; 1995-1989; V-6 3.0 Eng.; "O" Ring; W/Water Cooled Trans. Cooler; 2 Reqd

Dodge; 600; 1988-1986; 4-Cyl. 2.2 Eng.; "O" Ring From Aux. Cooler; 2 Reqd

Dodge; 600; 1988-1986; 4-Cyl. 2.5 Eng.; "O" Ring From Aux. Cooler; 2 Reqd

Ply; Acclaim; 1990-1989; 4-Cyl. 2.5 Eng.; "O" Ring; 2 Reqd

Ply; Acclaim; 1990-1989; V-6 3.0 Eng.; "O" Ring; 2 Reqd

Ply; Caravelle; 1988; 4-Cyl. 2.2 Eng.; "O" Ring From Aux. Cooler; 2 Reqd

Ply; Caravelle; 1987-1986; 4-Cyl. 2.2 Eng.; "O" Ring; W/Water Cooled Trans. Cooler; 2 Reqd

Ply; Caravelle; 1988; 4-Cyl. 2.5 Eng.; "O" Ring From Aux. Cooler; 2 Reqd

Ply; Caravelle; 1987-1986; 4-Cyl. 2.5 Eng.; "O" Ring; W/Water Cooled Trans. Cooler; 2 Reqd

Ply; Grand Voyager; 1989-1988; 4-Cyl. 2.5 Eng.; "O" Ring; W/Water Cooled Trans. Cooler; 2 Reqd

Ply; Grand Voyager; 1995-1992; V-6 3.0 Eng.; "O" Ring; W/Water Cooled Trans. Cooler; 2 Reqd

## A63093 - Continued

Ply; Grand Voyager; 1989; V-6 3.0 Eng.; "O" Ring; W/Water Cooled Trans. Cooler; 2 Reqd

Ply; Grand Voyager; 1995-1990; V-6 3.3 Eng.; "O" Ring; W/Water Cooled Trans. Cooler; 2 Reqd

Ply; Grand Voyager; 1995-1994; V-6 3.8 Eng.; "O" Ring; W/Water Cooled Trans. Cooler; 2 Reqd

Ply; Horizon; 1990; 4-Cyl. 2.2 Eng.; "O" Ring; W/Water Cooled Trans. Cooler; 2 Reqd

Ply; Horizon; 1989-1987; 4-Cyl. 2.2 Eng.; "O" Ring; W/AC; 2 Reqd

Ply; Reliant; 1989-1988; 4-Cyl. 2.2 Eng.; "O" Ring From Aux. Cooler; 2 Reqd

Ply; Reliant; 1987-1986; 4-Cyl. 2.2 Eng.; "O" Ring; W/Water Cooled Trans. Cooler; 2 Reqd

Ply; Reliant; 1989-1988; 4-Cyl. 2.5 Eng.; "O" Ring From Aux. Cooler; 2 Reqd

Ply; Reliant; 1987-1986; 4-Cyl. 2.5 Eng.; "O" Ring; W/Water Cooled Trans. Cooler; 2 Reqd

Ply; Sundance; 1990-1987; 4-Cyl. 2.2 Eng.; "O" Ring; W/O Water Cooled Trans. Cooler; 2 Reqd

Ply; Sundance; 1991-1988; 4-Cyl. 2.5 Eng.; "O" Ring; W/O Water Cooled Trans. Cooler; 2 Reqd

Ply; Voyager; 1995-1990; 4-Cyl. 2.5 Eng.; "O" Ring; W/Water Cooled Trans. Cooler; 2 Reqd

Ply; Voyager; 1995-1990; V-6 3.0 Eng.; "O" Ring; W/Water Cooled Trans. Cooler; 2 Reqd

Ply; Voyager; 1995-1991; V-6 3.3 Eng.; "O" Ring; W/Water Cooled Trans. Cooler; 2 Reqd

## A63094

Ford; Bronco; 1992-1991; 6-Cyl. 4.9 Eng.; "O" Ring (Connector & Fitting); As Reqd

Ford; Bronco; 1996-1991; V-8 5.0 Eng.; "O" Ring (Connector & Fitting); As Reqd

Ford; Bronco; 1996-1991; V-8 5.8 Eng.; "O" Ring (Connector & Fitting); As Reqd

Ford; Bronco Full Size; 1990-1988; 6-Cyl. 4.9 Eng.; "O" Ring (Connector & Fitting); As Reqd

Ford; Bronco Full Size; 1990-1988; V-8 5.0 Eng.; "O" Ring (Connector & Fitting); As Reqd

Ford; Bronco Full Size; 1990-1988; V-8 5.8 Eng.; "O" Ring (Connector & Fitting); As Reqd

Ford; Country Squire; 1991-1989; V-8 5.0 Eng.; "O" Ring (Connector & Fitting); As Reqd

Ford; Country Squire; 1988; V-8 5.0 Eng.; "O" Ring (Connector); 2 Reqd

Ford; Country Squire; 1988; V-8 5.0 Eng.; "O" Ring (Fitting); 4-18 & Newer; 2 Reqd

Ford; Crown Victoria; 2003-2000; V-8 4.6 Eng.; "O" Ring (Fitting); As Reqd

Ford; Crown Victoria; 1999-1992; V-8 4.6 Eng.; "O" Ring (Connector & Fitting); As Reqd

Ford; E Van; 1996-1988; 6-Cyl. 4.9 Eng.; "O" Ring (Connector & Fitting); As Reqd

Ford; E Van; 2003-1997; V-6 4.2 Eng.; "O" Ring (Connector & Fitting); As Reqd

Ford; E Van; 2003-1997; V-8 4.6 Eng.; "O" Ring (Connector & Fitting); As Reqd

Ford; E Van; 1996-1988; V-8 5.0 Eng.; "O" Ring (Connector & Fitting); As Reqd

Ford; E Van; 2003-1997; V-8 5.4 Eng.; "O" Ring (Connector); As Reqd

Ford; E Van; 1996-1988; V-8 5.8 Eng.; "O" Ring (Connector & Fitting); As Reqd

Ford; E Van; 1998-1997; V-8 7.3 Diesel Eng.; "O" Ring (Connector); As Reqd

Ford; E Van; 1996-1988; V-8 7.3 Diesel Eng.; "O" Ring (Connector & Fitting); As Reqd

Ford; E Van; 1996-1988; V-8 7.5 Eng.; "O" Ring (Connector & Fitting); As Reqd

Ford; E Van; 1998-1997; V-10 6.8 Eng.; "O" Ring (Connector); As Reqd

Ford; Escort; 1990-1988; 4-Cyl. 1.9 Eng.; "O" Ring (Connector & Fitting); As Reqd

Ford; Excursion; 2001; V-8 7.3 Diesel Eng.; "O" Ring (Connector); As Reqd

Ford; Expedition; 2002-1999; V-8 4.6 Eng.; "O" Ring (Connector & Fitting); W/5/16" Tubing; As Reqd

Ford; Expedition; 1998-1997; V-8 4.6 Eng.; "O" Ring (Connector & Fitting); As Reqd

Ford; F Pickup; 1996-1990; 6-Cyl. 4.9 Eng.; "O" Ring (Connector & Fitting); As Reqd

Ford; F Pickup; 2001-2000; V-6 4.2 Eng.; "O" Ring (Connector & Fitting); W/5/16" Tubing; As Reqd

Ford; F Pickup; 1999-1998; V-6 4.2 Eng.; "O" Ring (Fitting); As Reqd

Ford; F Pickup; 1997; V-6 4.2 Eng.; "O" Ring (Connector & Fitting); As Reqd

# Numerical Listing - Oil Cooler Assemblies & End Fittings

## A63094 - Continued

Ford; F Pickup; 2001-2000; V-8 4.6 Eng.; "O" Ring (Connector & Fitting); W/5/16" Tubing; As Reqd  
 Ford; F Pickup; 1999-1998; V-8 4.6 Eng.; "O" Ring (Fitting); As Reqd  
 Ford; F Pickup; 1997; V-8 4.6 Eng.; "O" Ring (Connector & Fitting); As Reqd  
 Ford; F Pickup; 1996-1990; V-8 5.0 Eng.; "O" Ring (Connector & Fitting); As Reqd  
 Ford; F Pickup; 2002-1997; V-8 5.4 Eng.; "O" Ring (Connector & Fitting); W/5/16" Tubing; As Reqd  
 Ford; F Pickup; 1996-1990; V-8 5.8 Eng.; "O" Ring (Connector & Fitting); As Reqd  
 Ford; F Pickup; 1996-1990; V-8 7.3 Diesel Eng.; "O" Ring (Connector & Fitting); As Reqd  
 Ford; F Pickup; 1996-1990; V-8 7.5 Eng.; "O" Ring (Connector & Fitting); As Reqd  
 Ford; Ltd Crown Victoria; 1991-1989; V-8 5.0 Eng.; "O" Ring (Connector & Fitting); As Reqd  
 Ford; Ltd Crown Victoria; 1988; V-8 5.0 Eng.; "O" Ring (Connector); 2 Reqd  
 Ford; Ltd Crown Victoria; 1988; V-8 5.0 Eng.; "O" Ring (Fitting); 4-18 & Newer; 2 Reqd  
 Ford; Ltd Crown Victoria; 1991-1989; V-8 5.8 Eng.; "O" Ring (Connector & Fitting); As Reqd  
 Ford; Ltd Crown Victoria; 1988; V-8 5.8 Eng.; "O" Ring (Connector); 2 Reqd  
 Ford; Ltd Crown Victoria; 1988; V-8 5.8 Eng.; "O" Ring (Fitting); 4-18 & Newer; 2 Reqd  
 Ford; Mustang; 1993; 4-Cyl. 2.3 Eng.; "O" Ring (Connector & Fitting); W/AOD Trans; As Reqd  
 Ford; Mustang; 1992-1990; 4-Cyl. 2.3 Eng.; "O" Ring (Connector & Fitting); W/AOD Trans.; As Reqd  
 Ford; Mustang; 1989-1988; 4-Cyl. 2.3 Eng.; "O" Ring (Connector & Fitting); W/AOD Trans; As Reqd  
 Ford; Mustang; 2002-1994; V-6 3.8 Eng.; "O" Ring (Connector & Fitting); As Reqd  
 Ford; Mustang; 2002-1997; V-8 4.6 Eng.; "O" Ring (Connector & Fitting); As Reqd  
 Ford; Mustang; 1995-1994; V-8 5.0 Eng.; "O" Ring (Connector & Fitting); As Reqd  
 Ford; Mustang; 1993; V-8 5.0 Eng.; "O" Ring (Connector & Fitting); W/AOD Trans; As Reqd  
 Ford; Mustang; 1992-1990; V-8 5.0 Eng.; "O" Ring (Connector & Fitting); W/AOD Trans.; As Reqd  
 Ford; Mustang; 1989; V-8 5.0 Eng.; "O" Ring (Connector & Fitting); W/AOD Trans; As Reqd  
 Ford; Mustang; 1995; V-8 5.8 Eng.; "O" Ring (Connector & Fitting); As Reqd  
 Ford; Super Duty Van; 2003-2001; V-6 4.2 Eng.; "O" Ring (Connector & Fitting); As Reqd  
 Ford; Super Duty Van; 2003; V-8 4.6 Eng.; "O" Ring (Connector & Fitting); As Reqd  
 Ford; Super Duty Van; 2003-1999; V-8 5.4 Eng.; "O" Ring (Connector & Fitting); As Reqd  
 Ford; Super Duty Van; 1998-1997; V-8 5.4 Eng.; "O" Ring (Connector); As Reqd  
 Ford; Super Duty Van; 2003-2002; V-8 7.3 Diesel Eng.; "O" Ring (Connector & Fitting); As Reqd  
 Ford; Super Duty Van; 2001-1997; V-8 7.3 Diesel Eng.; "O" Ring (Connector); As Reqd  
 Ford; Super Duty Van; 2003-2002; V-10 6.8 Eng.; "O" Ring (Connector & Fitting); As Reqd  
 Ford; Super Duty Van; 2001-1997; V-10 6.8 Eng.; "O" Ring (Connector); As Reqd  
 Ford; Taurus; 1991-1986; 4-Cyl. 2.5 Eng.; "O" Ring (Connector); As Reqd  
 Ford; Taurus; 1995-1986; V-6 3.0 Eng.; "O" Ring (Connector); As Reqd  
 Ford; Taurus; 1995-1988; V-6 3.8 Eng.; "O" Ring (Connector); As Reqd  
 Ford; Thunderbird; 1988; 4-Cyl. 2.3 Eng.; "O" Ring (Connector); As Reqd  
 Ford; Thunderbird; 1988; 4-Cyl. 2.3 Eng.; "O" Ring (Fitting); 4-18 & Newer; As Reqd  
 Ford; Thunderbird; 1997-1989; V-6 3.8 Eng.; "O" Ring (Connector & Fitting); As Reqd  
 Ford; Thunderbird; 1988; V-6 3.8 Eng.; "O" Ring (Connector); As Reqd  
 Ford; Thunderbird; 1988; V-6 3.8 Eng.; "O" Ring (Fitting); 4-18 & Newer; As Reqd  
 Ford; Thunderbird; 1997-1994; V-8 4.6 Eng.; "O" Ring (Connector & Fitting); As Reqd  
 Ford; Thunderbird; 1993-1991; V-8 5.0 Eng.; "O" Ring (Connector & Fitting); As Reqd  
 Ford; Thunderbird; 1988; V-8 5.0 Eng.; "O" Ring (Connector); As Reqd  
 Ford; Thunderbird; 1988; V-8 5.0 Eng.; "O" Ring (Fitting); 4-18 & Newer; As Reqd  
 Linc; Continental; 1989-1988; V-6 3.8 Eng.; "O" Ring (Connector & Fitting); As Reqd

## A63094 - Continued

Linc; Mark VII; 1992-1988; V-8 5.0 Eng.; "O" Ring (Connector & Fitting); As Reqd  
 Linc; Mark VIII; 1998-1996; V-8 4.6 Eng.; "O" Ring (Fitting); As Reqd  
 Linc; Mark VIII; 1995-1993; V-8 4.6 Eng.; "O" Ring (Connector & Fitting); As Reqd  
 Linc; Town Car; 2003-1996; V-8 4.6 Eng.; "O" Ring (Fitting); As Reqd  
 Linc; Town Car; 1995-1991; V-8 4.6 Eng.; "O" Ring (Connector & Fitting); As Reqd  
 Linc; Town Car; 1990-1989; V-8 5.0 Eng.; "O" Ring (Connector & Fitting); As Reqd  
 Linc; Town Car; 1988; V-8 5.0 Eng.; "O" Ring (Connector); As Reqd  
 Linc; Town Car; 1988; V-8 5.0 Eng.; "O" Ring (Fitting); 4-18 & Newer; As Reqd  
 Merc; Colony Park; 1991-1989; V-8 5.0 Eng.; "O" Ring (Connector & Fitting); As Reqd  
 Merc; Colony Park; 1988; V-8 5.0 Eng.; "O" Ring (Connector); 2 Reqd  
 Merc; Colony Park; 1988; V-8 5.0 Eng.; "O" Ring (Fitting); 4-18 & Newer; 2 Reqd  
 Merc; Cougar; 1997-1989; V-6 3.8 Eng.; "O" Ring (Connector & Fitting); As Reqd  
 Merc; Cougar; 1988; V-6 3.8 Eng.; "O" Ring (Connector); As Reqd  
 Merc; Cougar; 1988; V-6 3.8 Eng.; "O" Ring (Fitting); 4-18 & Newer; As Reqd  
 Merc; Cougar; 1997-1994; V-8 4.6 Eng.; "O" Ring (Connector & Fitting); As Reqd  
 Merc; Cougar; 1993-1991; V-8 5.0 Eng.; "O" Ring (Connector & Fitting); As Reqd  
 Merc; Cougar; 1988; V-8 5.0 Eng.; "O" Ring (Connector); As Reqd  
 Merc; Cougar; 1988; V-8 5.0 Eng.; "O" Ring (Fitting); 4-18 & Newer; As Reqd  
 Merc; Grand Marquis; 1999-1992; V-8 4.6 Eng.; "O" Ring (Connector & Fitting); As Reqd  
 Merc; Grand Marquis; 1991-1989; V-8 5.0 Eng.; "O" Ring (Connector & Fitting); As Reqd  
 Merc; Grand Marquis; 1988; V-8 5.0 Eng.; "O" Ring (Connector); 2 Reqd  
 Merc; Grand Marquis; 1988; V-8 5.0 Eng.; "O" Ring (Fitting); 4-18 & Newer; 2 Reqd  
 Merc; Grand Marquis; 1989; V-8 5.8 (Canada) Eng.; "O" Ring (Connector & Fitting); As Reqd  
 Merc; Grand Marquis; 1988; V-8 5.8 (Canada) Eng.; "O" Ring (Connector); 2 Reqd  
 Merc; Grand Marquis; 1988; V-8 5.8 (Canada) Eng.; "O" Ring (Fitting); 4-18 & Newer; 2 Reqd  
 Merc; Sable; 1986; 4-Cyl. 2.5 Eng.; "O" Ring (Connector); As Reqd  
 Merc; Sable; 1995-1986; V-6 3.0 Eng.; "O" Ring (Connector); As Reqd  
 Merc; Sable; 1995-1988; V-6 3.8 Eng.; "O" Ring (Connector); As Reqd  
 Merc; Tracer; 1989-1988; 4-Cyl. 1.6 Eng.; "O" Ring (Connector & Fitting); As Reqd

## A63096

Jeep; Cherokee; 1996-1988; 4-Cyl. 2.5 Eng.; "O" Ring From Rad; 2 Reqd  
 Jeep; Cherokee; 2001-1997; 6-Cyl. 4.0 Eng.; "O" Ring To Trans.; 2 Reqd  
 Jeep; Cherokee; 1996-1988; 6-Cyl. 4.0 Eng.; "O" Ring From Rad; 2 Reqd  
 Jeep; Comanche; 1992-1988; 4-Cyl. 2.5 Eng.; "O" Ring From Rad; 2 Reqd  
 Jeep; Comanche; 1992-1988; 6-Cyl. 4.0 Eng.; "O" Ring From Rad; 2 Reqd  
 Jeep; Wagoneer; 1990-1988; 6-Cyl. 4.0 Eng.; "O" Ring From Rad; 2 Reqd

## A63097

Dodge; Stealth; 1994-1991; V-6 3.0 Eng.; "O" Ring To Trans.; 2 Reqd  
 Eagle; Talon; 1994-1993; 4-Cyl. 1.8 Eng.; "O" Ring To Trans.; 2 Reqd  
 Eagle; Talon; 1994-1990; 4-Cyl. 2.0 Eng.; "O" Ring To Trans.; 2 Reqd  
 Ply; Laser; 1994-1990; 4-Cyl. 1.8 Eng.; "O" Ring To Trans.; 2 Reqd  
 Ply; Laser; 1994-1990; 4-Cyl. 2.0 Eng.; "O" Ring To Trans.; 2 Reqd

## A63098

Buick; Century; 2003-2000; V-6 3.1 Eng.; Wire Retainer (Connectors & Fittings); As Reqd  
 Buick; Century; 1999-1998; V-6 3.1 Eng.; Wire Retainer (Connectors & Fittings); 2 Reqd  
 Buick; Lesabre; 2005-2000; V-6 3.8 Eng.; Wire Retainer (Connectors & Fittings); 4 Reqd  
 Buick; Park Ave.; 2005-2000; V-6 3.8 Eng.; Wire Retainer (Connectors & Fittings); 4 Reqd  
 Buick; Rainier; 2004; 6-Cyl. 4.2 Eng.; Wire Retainer (Connectors & Fittings); As Reqd  
 Buick; Rainier; 2004; V-8 5.3 Eng.; Wire Retainer (Connectors & Fittings); As Reqd  
 Buick; Regal; 2003-2000; V-6 3.8 Eng.; Wire Retainer (Connectors & Fittings); As Reqd

## Numerical Listing - Oil Cooler Assemblies & End Fittings

### A63098 - Continued

Buick; Regal; 1999-1998; V-6 3.8 Eng.; Wire Retainer (Connectors); As Reqd  
 Buick; Rendezvous; 2003-2002; V-6 3.4 Eng.; Wire Retainer (Connectors & Fittings); As Reqd  
 Cad; Deville; 2003-2001; V-8 4.6 Eng.; Wire Retainer (Connectors & Fittings); As Reqd  
 Cad; Deville; 2000; V-8 4.6 Eng.; Wire Retainer (Connectors)  
 Cad; Eldorado; 2002-2001; V-8 4.6 Eng.; Wire Retainer (Connectors)  
 Cad; Escalade; 2004-2002; V-8 5.3 Eng.; Wire Retainer (Connectors & Fittings); As Reqd  
 Cad; Escalade; 2000-1999; V-8 5.7 Eng.; Wire Retainer (Connectors & Fittings); W/3/8" Retainer; As Reqd  
 Cad; Escalade; 2004-2002; V-8 6.0 Eng.; Wire Retainer (Connectors & Fittings); As Reqd  
 Cad; Seville; 2003-2000; V-8 4.6 Eng.; Wire Retainer (Connectors)  
 Chev; Astro; 2005-1996; V-6 4.3 Eng.; Wire Retainer (Connectors & Fittings); 4 Reqd  
 Chev; Avalanche; 2003-2002; V-8 5.3 Eng.; Wire Retainer (Connectors & Fittings); As Reqd  
 Chev; Avalanche; 2003-2002; V-8 8.1 Eng.; Wire Retainer (Connectors & Fittings); As Reqd  
 Chev; Blazer; 2004-1996; V-6 4.3 Eng.; Wire Retainer (Connectors & Fittings); As Reqd  
 Chev; C&K Pickup; 1998-1997; V-6 4.3 Eng.; Wire Retainer (Fittings); W/3/8" Retainer; As Reqd  
 Chev; C&K Pickup; 1996; V-6 4.3 Eng.; Wire Retainer (Fittings); As Reqd  
 Chev; C&K Pickup; 1999-1997; V-8 5.0 Eng.; Wire Retainer (Fittings); W/3/8" Retainer; As Reqd  
 Chev; C&K Pickup; 1996; V-8 5.0 Eng.; Wire Retainer (Fittings); As Reqd  
 Chev; C&K Pickup; 2000-1996; V-8 5.7 Eng.; Wire Retainer (Connectors & Fittings); W/3/8" Retainer; As Reqd  
 Chev; C&K Pickup; 2002-1996; V-8 6.5 Diesel Eng.; Wire Retainer (Connectors & Fittings); W/3/8" Retainer; As Reqd  
 Chev; C&K Pickup; 2000-1996; V-8 7.4 Eng.; Wire Retainer (Connectors & Fittings); W/3/8" Retainer; As Reqd  
 Chev; C&K Pickup; 2002-2001; V-8 8.1 Eng.; Wire Retainer (Connectors & Fittings); W/3/8" Retainer; As Reqd  
 Chev; Camaro; 2002-1998; V-6 3.8 Eng.; Wire Retainer (Fittings); 2 Reqd  
 Chev; Camaro; 2002-1998; V-8 5.7 Eng.; Wire Retainer (Fittings); 2 Reqd  
 Chev; Express; 2003; V-6 4.3 Eng.; Wire Retainer (Fittings); As Reqd  
 Chev; Express; 2002-1996; V-6 4.3 Eng.; Wire Retainer (Connectors & Fittings); As Reqd  
 Chev; Express; 2003; V-8 4.8 Eng.; Wire Retainer (Connectors & Fittings); As Reqd  
 Chev; Express; 2002-1996; V-8 5.0 Eng.; Wire Retainer (Connectors & Fittings); As Reqd  
 Chev; Express; 2003; V-8 5.3 Eng.; Wire Retainer (Fittings); As Reqd  
 Chev; Express; 2002-1996; V-8 5.7 Eng.; Wire Retainer (Connectors & Fittings); As Reqd  
 Chev; Express; 2003; V-8 6.0 Eng.; Wire Retainer (Fittings); As Reqd  
 Chev; Express; 2002-1996; V-8 6.5 Diesel Eng.; Wire Retainer (Fittings); As Reqd  
 Chev; Express; 2000-1996; V-8 7.4 Eng.; Wire Retainer (Fittings); As Reqd  
 Chev; Express; 2002-2001; V-8 8.1 Eng.; Wire Retainer (Fittings); As Reqd  
 Chev; G Van; 1998-1997; V-6 4.3 Eng.; Wire Retainer (Connectors & Fittings); As Reqd  
 Chev; G Van; 1998-1997; V-8 5.0 Eng.; Wire Retainer (Connectors & Fittings); As Reqd  
 Chev; G Van; 1998-1997; V-8 5.7 Eng.; Wire Retainer (Connectors & Fittings); As Reqd  
 Chev; G Van; 1998-1997; V-8 6.5 Diesel Eng.; Wire Retainer (Fittings); As Reqd  
 Chev; G Van; 1998-1997; V-8 7.4 Eng.; Wire Retainer (Fittings); As Reqd  
 Chev; Impala; 2003-2000; V-6 3.4 Eng.; Wire Retainer (Connectors & Fittings); As Reqd  
 Chev; Impala; 2003-2000; V-6 3.8 Eng.; Wire Retainer (Connectors & Fittings); As Reqd  
 Chev; Lumina; 2001-1998; V-6 3.1 Eng.; Wire Retainer (Connectors & Fittings); As Reqd  
 Chev; Lumina; 1999-1998; V-6 3.8 Eng.; Wire Retainer (Connectors & Fittings); As Reqd  
 Chev; Monte Carlo; 1999-1998; V-6 3.1 Eng.; Wire Retainer (Connectors & Fittings); As Reqd  
 Chev; Monte Carlo; 2003-2000; V-6 3.4 Eng.; Wire Retainer (Connectors & Fittings); As Reqd  
 Chev; Monte Carlo; 2003-1998; V-6 3.8 Eng.; Wire Retainer (Connectors & Fittings); As Reqd  
 Chev; S Pickup; 2003-1998; 4-Cyl. 2.2 Eng.; Wire Retainer (Connectors & Fittings); As Reqd  
 Chev; S Pickup; 2004-1996; V-6 4.3 Eng.; Wire Retainer (Connectors & Fittings); As Reqd

### A63098 - Continued

Chev; Silverado Pickup; 2003-1999; V-6 4.3 Eng.; Wire Retainer (Connectors & Fittings); As Reqd  
 Chev; Silverado Pickup; 2003-1999; V-8 4.8 Eng.; Wire Retainer (Connectors & Fittings); As Reqd  
 Chev; Silverado Pickup; 2003-1999; V-8 5.3 Eng.; Wire Retainer (Connectors & Fittings); As Reqd  
 Chev; Silverado Pickup; 2003-2001; V-8 6.0 Eng.; Wire Retainer (Connectors & Fittings); As Reqd  
 Chev; Silverado Pickup; 2000-1999; V-8 6.0 Eng.; Wire Retainer (Aux. Cooler); As Reqd  
 Chev; Silverado Pickup; 1999; V-8 6.5 Diesel Eng.; Wire Retainer (Connectors & Fittings); W/3/8" Retainer; As Reqd  
 Chev; Silverado Pickup; 2003-2001; V-8 8.1 Eng.; Wire Retainer (Connectors & Fittings); As Reqd  
 Chev; SSR; 2003; V-8 5.3 Eng.; Wire Retainer (Fittings); As Reqd  
 Chev; Suburban; 2003-2000; V-8 5.3 Eng.; Wire Retainer (Connectors & Fittings); As Reqd  
 Chev; Suburban; 1999-1996; V-8 5.7 Eng.; Wire Retainer (Connectors & Fittings); W/3/8" Retainer; As Reqd  
 Chev; Suburban; 2003-2001; V-8 6.0 Eng.; Wire Retainer (Connectors & Fittings); As Reqd  
 Chev; Suburban; 2000; V-8 6.0 Eng.; Wire Retainer (Aux. Cooler); As Reqd  
 Chev; Suburban; 1999-1996; V-8 6.5 Diesel Eng.; Wire Retainer (Connectors & Fittings); W/3/8" Retainer; As Reqd  
 Chev; Suburban; 1999-1996; V-8 7.4 Eng.; Wire Retainer (Connectors & Fittings); W/3/8" Retainer; As Reqd  
 Chev; Suburban; 2003-2001; V-8 8.1 Eng.; Wire Retainer (Connectors & Fittings); As Reqd  
 Chev; Tahoe; 2003-2000; V-8 4.8 Eng.; Wire Retainer (Connectors & Fittings); As Reqd  
 Chev; Tahoe; 2003-2000; V-8 5.3 Eng.; Wire Retainer (Connectors & Fittings); As Reqd  
 Chev; Tahoe; 2000-1996; V-8 5.7 Eng.; Wire Retainer (Connectors & Fittings); W/3/8" Retainer; As Reqd  
 Chev; Tahoe; 1999-1996; V-8 6.5 Diesel Eng.; Wire Retainer (Connectors & Fittings); W/3/8" Retainer; As Reqd  
 Chev; Trailblazer; 2004-2002; 6-Cyl. 4.2 Eng.; Wire Retainer (Connectors & Fittings); As Reqd  
 Chev; Trailblazer; 2004-2003; V-8 5.3 Eng.; Wire Retainer (Connectors & Fittings); As Reqd  
 Chev; Venture; 2003-2000; V-6 3.4 Eng.; Wire Retainer (Connectors & Fittings); As Reqd  
 GMC; C&K Pickup; 1998-1997; V-6 4.3 Eng.; Wire Retainer (Fittings); W/3/8" Retainer; As Reqd  
 GMC; C&K Pickup; 1996; V-6 4.3 Eng.; Wire Retainer (Fittings); As Reqd  
 GMC; C&K Pickup; 1999-1997; V-8 5.0 Eng.; Wire Retainer (Fittings); W/3/8" Retainer; As Reqd  
 GMC; C&K Pickup; 1996; V-8 5.0 Eng.; Wire Retainer (Fittings); As Reqd  
 GMC; C&K Pickup; 2000-1996; V-8 5.7 Eng.; Wire Retainer (Connectors & Fittings); W/3/8" Retainer; As Reqd  
 GMC; C&K Pickup; 2002-1996; V-8 6.5 Diesel Eng.; Wire Retainer (Connectors & Fittings); W/3/8" Retainer; As Reqd  
 GMC; C&K Pickup; 2000-1996; V-8 7.4 Eng.; Wire Retainer (Connectors & Fittings); W/3/8" Retainer; As Reqd  
 GMC; C&K Pickup; 2002-2001; V-8 8.1 Eng.; Wire Retainer (Connectors & Fittings); W/3/8" Retainer; As Reqd  
 GMC; Envoy; 2004-2002; 6-Cyl. 4.2 Eng.; Wire Retainer (Connectors & Fittings); As Reqd  
 GMC; Envoy; 2004-2003; V-8 5.3 Eng.; Wire Retainer (Connectors & Fittings); As Reqd  
 GMC; Jimmy; 2001-1996; V-6 4.3 Eng.; Wire Retainer (Connectors & Fittings); As Reqd  
 GMC; Jimmy; 2004-2002; V-6 4.3 (Canada) Eng.; Wire Retainer (Connectors & Fittings); As Reqd  
 GMC; Safari; 2005-1996; V-6 4.3 Eng.; Wire Retainer (Connectors & Fittings); 4 Reqd  
 GMC; Savana; 2003; V-6 4.3 Eng.; Wire Retainer (Fittings); As Reqd  
 GMC; Savana; 2002-1996; V-6 4.3 Eng.; Wire Retainer (Connectors & Fittings); As Reqd  
 GMC; Savana; 2003; V-8 4.8 Eng.; Wire Retainer (Connectors & Fittings); As Reqd  
 GMC; Savana; 2002-1996; V-8 5.0 Eng.; Wire Retainer (Connectors & Fittings); As Reqd  
 GMC; Savana; 2003; V-8 5.3 Eng.; Wire Retainer (Fittings); As Reqd  
 GMC; Savana; 2002-1996; V-8 5.7 Eng.; Wire Retainer (Connectors & Fittings); As Reqd  
 GMC; Savana; 2003; V-8 6.0 Eng.; Wire Retainer (Fittings); As Reqd  
 GMC; Savana; 2002-1996; V-8 6.5 Diesel Eng.; Wire Retainer (Fittings); As Reqd  
 GMC; Savana; 2000-1996; V-8 7.4 Eng.; Wire Retainer (Fittings); As Reqd  
 GMC; Savana; 2002-2001; V-8 8.1 Eng.; Wire Retainer (Fittings); As Reqd  
 GMC; Sierra Pickup; 2003-1999; V-6 4.3 Eng.; Wire Retainer (Connectors & Fittings); As Reqd

# Numerical Listing - Oil Cooler Assemblies & End Fittings

## A63098 - Continued

GMC; Sierra Pickup; 2002-1999; V-8 4.8 Eng.; Wire Retainer (Connectors & Fittings); As Reqd  
 GMC; Sierra Pickup; 2003-1999; V-8 5.3 Eng.; Wire Retainer (Connectors & Fittings); As Reqd  
 GMC; Sierra Pickup; 2003-2001; V-8 6.0 Eng.; Wire Retainer (Connectors & Fittings); As Reqd  
 GMC; Sierra Pickup; 2000-1999; V-8 6.0 Eng.; Wire Retainer (Aux. Cooler); As Reqd  
 GMC; Sierra Pickup; 1999; V-8 6.5 Diesel Eng.; Wire Retainer (Connectors & Fittings); W/3/8" Retainer; As Reqd  
 GMC; Sierra Pickup; 2003-2001; V-8 8.1 Eng.; Wire Retainer (Connectors & Fittings); As Reqd  
 GMC; Sonoma; 2003-1998; 4-Cyl. 2.2 Eng.; Wire Retainer (Connectors & Fittings); As Reqd  
 GMC; Sonoma; 2004-1996; V-6 4.3 Eng.; Wire Retainer (Connectors & Fittings); As Reqd  
 GMC; Suburban; 1999-1996; V-8 5.7 Eng.; Wire Retainer (Connectors & Fittings); W/3/8" Retainer; As Reqd  
 GMC; Suburban; 1999-1996; V-8 6.5 Diesel Eng.; Wire Retainer (Connectors & Fittings); W/3/8" Retainer; As Reqd  
 GMC; Suburban; 1999-1996; V-8 7.4 Eng.; Wire Retainer (Connectors & Fittings); W/3/8" Retainer; As Reqd  
 GMC; Yukon; 2003-2000; V-8 4.8 Eng.; Wire Retainer (Connectors & Fittings); As Reqd  
 GMC; Yukon; 2003-2000; V-8 5.3 Eng.; Wire Retainer (Connectors & Fittings); As Reqd  
 GMC; Yukon; 2000-1996; V-8 5.7 Eng.; Wire Retainer (Connectors & Fittings); W/3/8" Retainer; As Reqd  
 GMC; Yukon; 2003-2001; V-8 6.0 Eng.; Wire Retainer (Connectors & Fittings); As Reqd  
 GMC; Yukon; 2000; V-8 6.0 Eng.; Wire Retainer (Aux. Cooler); As Reqd  
 GMC; Yukon; 1997-1996; V-8 6.5 Diesel Eng.; Wire Retainer (Connectors & Fittings); W/3/8" Retainer; As Reqd  
 GMC; Yukon; 2003-2001; V-8 8.1 Eng.; Wire Retainer (Connectors & Fittings); As Reqd  
 Olds; Aurora; 2002-2001; V-6 3.5 Eng.; Wire Retainer (Connectors); 2 Reqd  
 Olds; Aurora; 2003-2001; V-8 4.0 Eng.; Wire Retainer (Connectors)  
 Olds; Aurora; 1999-1995; V-8 4.0 Eng.; Wire Retainer (Connectors)  
 Olds; Bravada; 2003-2002; 6-Cyl. 4.2 Eng.; Wire Retainer (Connectors & Fittings); As Reqd  
 Olds; Bravada; 2001-1996; V-6 4.3 Eng.; Wire Retainer (Connectors & Fittings); As Reqd  
 Olds; Intrigue; 2002-2000; V-6 3.5 Eng.; Wire Retainer (Connectors & Fittings); 4 Reqd  
 Olds; Intrigue; 1999; V-6 3.5 Eng.; Wire Retainer (Connectors); 2 Reqd  
 Olds; Silhouette; 2003-2000; V-6 3.4 Eng.; Wire Retainer (Connectors & Fittings); As Reqd  
 Pont; Aztek; 2003-2001; V-6 3.4 Eng.; Wire Retainer (Connectors & Fittings); As Reqd  
 Pont; Bonneville; 2005-2000; V-6 3.8 Eng.; Wire Retainer (Connectors & Fittings); 4 Reqd  
 Pont; Firebird; 2002-1998; V-6 3.8 Eng.; Wire Retainer (Fittings); 2 Reqd  
 Pont; Firebird; 2002-1998; V-8 5.7 Eng.; Wire Retainer (Fittings); 2 Reqd  
 Pont; Grand Prix; 2003-1998; V-6 3.1 Eng.; Wire Retainer (Connectors & Fittings); As Reqd  
 Pont; Grand Prix; 2003-1998; V-6 3.8 Eng.; Wire Retainer (Connectors & Fittings); As Reqd  
 Pont; Montana; 2003-2000; V-6 3.4 Eng.; Wire Retainer (Connectors & Fittings); As Reqd

## A63099

Cad; Escalade; 2000-1999; V-8 5.7 Eng.; Wire Retainer (Connectors & Fittings); W/5/8" Retainer; As Reqd  
 Chev; C&K Pickup; 1998-1997; V-6 4.3 Eng.; Wire Retainer (Fittings); W/5/8" Retainer; As Reqd  
 Chev; C&K Pickup; 1999-1997; V-8 5.0 Eng.; Wire Retainer (Fittings); W/5/8" Retainer; As Reqd  
 Chev; C&K Pickup; 2000-1996; V-8 5.7 Eng.; Wire Retainer (Connectors & Fittings); W/5/8" Retainer; As Reqd  
 Chev; C&K Pickup; 2002-1996; V-8 6.5 Diesel Eng.; Wire Retainer (Connectors & Fittings); W/5/8" Retainer; As Reqd  
 Chev; C&K Pickup; 2000-1996; V-8 7.4 Eng.; Wire Retainer (Connectors & Fittings); W/5/8" Retainer; As Reqd  
 Chev; C&K Pickup; 2002-2001; V-8 8.1 Eng.; Wire Retainer (Connectors & Fittings); W/5/8" Retainer; As Reqd  
 Chev; Silverado Pickup; 1999; V-8 6.5 Diesel Eng.; Wire Retainer (Connectors & Fittings); W/5/8" Retainer; As Reqd  
 Chev; Silverado Pickup; 2002-2001; V-8 6.6 Diesel Eng.; Wire Retainer (Aux. Cooler); 2 Reqd  
 Chev; Suburban; 1999-1996; V-8 5.7 Eng.; Wire Retainer (Connectors & Fittings); W/5/8" Retainer; As Reqd

## A63099 - Continued

Chev; Suburban; 1999-1996; V-8 6.5 Diesel Eng.; Wire Retainer (Connectors & Fittings); W/5/8" Retainer; As Reqd  
 Chev; Suburban; 1999-1996; V-8 7.4 Eng.; Wire Retainer (Connectors & Fittings); W/5/8" Retainer; As Reqd  
 Chev; Tahoe; 2000-1996; V-8 5.7 Eng.; Wire Retainer (Connectors & Fittings); W/5/8" Retainer; As Reqd  
 Chev; Tahoe; 1999-1996; V-8 6.5 Diesel Eng.; Wire Retainer (Connectors & Fittings); W/5/8" Retainer; As Reqd  
 GMC; C&K Pickup; 1998-1997; V-6 4.3 Eng.; Wire Retainer (Fittings); W/5/8" Retainer; As Reqd  
 GMC; C&K Pickup; 1999-1997; V-8 5.0 Eng.; Wire Retainer (Fittings); W/5/8" Retainer; As Reqd  
 GMC; C&K Pickup; 2000-1996; V-8 5.7 Eng.; Wire Retainer (Connectors & Fittings); W/5/8" Retainer; As Reqd  
 GMC; C&K Pickup; 2002-1996; V-8 6.5 Diesel Eng.; Wire Retainer (Connectors & Fittings); W/5/8" Retainer; As Reqd  
 GMC; C&K Pickup; 2000-1996; V-8 7.4 Eng.; Wire Retainer (Connectors & Fittings); W/5/8" Retainer; As Reqd  
 GMC; C&K Pickup; 2002-2001; V-8 8.1 Eng.; Wire Retainer (Connectors & Fittings); W/5/8" Retainer; As Reqd  
 GMC; Sierra Pickup; 1999; V-8 6.5 Diesel Eng.; Wire Retainer (Connectors & Fittings); W/5/8" Retainer; As Reqd  
 GMC; Sierra Pickup; 2002-2001; V-8 6.6 Diesel Eng.; Wire Retainer (Aux. Cooler); 2 Reqd  
 GMC; Suburban; 1999-1996; V-8 5.7 Eng.; Wire Retainer (Connectors & Fittings); W/5/8" Retainer; As Reqd  
 GMC; Suburban; 1999-1996; V-8 6.5 Diesel Eng.; Wire Retainer (Connectors & Fittings); W/5/8" Retainer; As Reqd  
 GMC; Suburban; 1999-1996; V-8 7.4 Eng.; Wire Retainer (Connectors & Fittings); W/5/8" Retainer; As Reqd  
 GMC; Yukon; 2000-1996; V-8 5.7 Eng.; Wire Retainer (Connectors & Fittings); W/5/8" Retainer; As Reqd  
 GMC; Yukon; 1997-1996; V-8 6.5 Diesel Eng.; Wire Retainer (Connectors & Fittings); W/5/8" Retainer; As Reqd

## A63100

Chry; Sebring; 2003-2001; 4-Cyl. 2.4 Eng.; Banjo Washers; W/SOHC; 4 Reqd  
 Chry; Sebring; 2003-2001; V-6 3.0 Eng.; Banjo Washers; 4 Reqd  
 Dodge; Stratus; 2003-2001; 4-Cyl. 2.4 Eng.; Banjo Washers; W/SOHC; 4 Reqd  
 Dodge; Stratus; 2003-2001; V-6 3.0 Eng.; Banjo Washers; 4 Reqd  
 Ford; Aspire; 1997-1994; 4-Cyl. 1.3 Eng.; Banjo Washers To Trans.; 2 Reqd  
 Ford; Probe; 1992-1990; 4-Cyl. 2.2 Eng.; Banjo Washers; W/12mm I.D. Banjo; As Reqd  
 Merc; Capri; 1994; 4-Cyl. 1.6 Eng.; Banjo Washers To Trans.; 2 Reqd

## A63101

Pont; Lemans; 1993-1988; 4-Cyl. 1.6 Eng.; Banjo Washers; As Reqd  
 Pont; Lemans; 1990-1989; 4-Cyl. 2.0 Eng.; Banjo Washers; As Reqd

## A63102

Pont; Lemans; 1993-1988; 4-Cyl. 1.6 Eng.; Banjo Seals; As Reqd  
 Pont; Lemans; 1990-1989; 4-Cyl. 2.0 Eng.; Banjo Seals; As Reqd

## A63103

Ford; Aspire; 1997-1994; 4-Cyl. 1.3 Eng.; Banjo Washers From Pump; 2 Reqd  
 Ford; Escort; 1995-1991; 4-Cyl. 1.8 Eng.; Banjo Washers; W/14mm I.D. Banjo; As Reqd  
 Ford; Escort; 1995-1991; 4-Cyl. 1.9 Eng.; Banjo Washers; W/14mm I.D. Banjo; As Reqd  
 Ford; Escort; 2002-1997; 4-Cyl. 2.0 Eng.; Banjo Washers; W/14mm I.D. Banjo; As Reqd  
 Ford; Probe; 1997-1993; 4-Cyl. 2.0 Eng.; Banjo Washers; W/14mm I.D. Banjo; As Reqd  
 Ford; Probe; 1997-1993; V-6 2.5 Eng.; Banjo Washers; W/14mm I.D. Banjo; As Reqd  
 Ford; ZX2; 2003; 4-Cyl. 2.0 Eng.; Banjo Washers; W/14mm I.D. Banjo; As Reqd  
 Merc; Capri; 1994; 4-Cyl. 1.6 Eng.; Banjo Washers From Pump; 2 Reqd  
 Merc; Tracer; 1996-1991; 4-Cyl. 1.8 Eng.; Banjo Washers; W/14mm I.D. Banjo; As Reqd  
 Merc; Tracer; 1996-1991; 4-Cyl. 1.9 Eng.; Banjo Washers; W/14mm I.D. Banjo; As Reqd  
 Merc; Tracer; 1999-1997; 4-Cyl. 2.0 Eng.; Banjo Washers; W/14mm I.D. Banjo; As Reqd

## Numerical Listing - Oil Cooler Assemblies & End Fittings

### A63104

Ford; Escort; 1995-1991; 4-Cyl. 1.8 Eng.; Banjo Washers; W/16mm I.D. Banjo; As Reqd  
 Ford; Escort; 1995-1991; 4-Cyl. 1.9 Eng.; Banjo Washers; W/16mm I.D. Banjo; As Reqd  
 Ford; Escort; 2002-1997; 4-Cyl. 2.0 Eng.; Banjo Washers; W/16mm I.D. Banjo; As Reqd  
 Ford; Probe; 1997-1993; 4-Cyl. 2.0 Eng.; Banjo Washers; W/16mm I.D. Banjo; As Reqd  
 Ford; Probe; 1992-1990; 4-Cyl. 2.2 Eng.; Banjo Washers; W/16mm I.D. Banjo; As Reqd  
 Ford; Probe; 1997-1993; V-6 2.5 Eng.; Banjo Washers; W/16mm I.D. Banjo; As Reqd  
 Ford; ZX2; 2003; 4-Cyl. 2.0 Eng.; Banjo Washers; W/16mm I.D. Banjo; As Reqd  
 Merc; Tracer; 1996-1991; 4-Cyl. 1.8 Eng.; Banjo Washers; W/16mm I.D. Banjo; As Reqd  
 Merc; Tracer; 1996-1991; 4-Cyl. 1.9 Eng.; Banjo Washers; W/16mm I.D. Banjo; As Reqd  
 Merc; Tracer; 1999-1997; 4-Cyl. 2.0 Eng.; Banjo Washers; W/16mm I.D. Banjo; As Reqd

### A63105

Ford; E Van; 1996-1988; 6-Cyl. 4.9 Eng.; By Pass Valve Washers (Front); W/.535 I.D. Washer; W/4-Spd AT; As Reqd  
 Ford; E Van; 1996-1988; V-8 5.0 Eng.; By Pass Valve Washers (Front); W/.535 I.D. Washer; W/4-Spd AT; As Reqd  
 Ford; E Van; 2003-1999; V-8 5.4 Eng.; By Pass Valve Washers (Front); W/4R100 Trans.; As Reqd  
 Ford; E Van; 1998-1997; V-8 5.4 Eng.; By Pass Valve Washers (Front); W/E4OD/4R100 Trans.; As Reqd  
 Ford; E Van; 1996-1988; V-8 5.8 Eng.; By Pass Valve Washers (Front); W/.535 I.D. Washer; W/4-Spd AT; As Reqd  
 Ford; E Van; 1998-1997; V-8 7.3 Diesel Eng.; By Pass Valve Washers (Front); As Reqd  
 Ford; E Van; 1996-1988; V-8 7.3 Diesel Eng.; By Pass Valve Washers (Front); W/.535 I.D. Washer; W/4-Spd AT; As Reqd  
 Ford; E Van; 1996-1988; V-8 7.5 Eng.; By Pass Valve Washers (Front); W/.535 I.D. Washer; W/4-Spd AT; As Reqd  
 Ford; E Van; 1998-1997; V-10 6.8 Eng.; By Pass Valve Washers (Front); As Reqd  
 Ford; Excursion; 2002-2000; V-8 5.4 Eng.; By Pass Valve Washers (Front); As Reqd  
 Ford; Excursion; 2002; V-8 7.3 Diesel Eng.; By Pass Valve Washers (Front); W/.535 I.D. Washer; As Reqd  
 Ford; Excursion; 2001; V-8 7.3 Diesel Eng.; By Pass Valve Washers (Front); As Reqd  
 Ford; Excursion; 2000; V-8 7.3 Diesel Eng.; By Pass Valve Washers (Front); W/.535 I.D. Washer; As Reqd  
 Ford; Excursion; 2002-2000; V-10 6.8 Eng.; By Pass Valve Washers (Front); As Reqd  
 Ford; Expedition; 2002-1997; V-8 5.4 Eng.; By Pass Valve Washers (Front); As Reqd  
 Ford; F Pickup; 2002-1998; V-8 5.4 Eng.; By Pass Valve Washers (Front); W/4R100 Trans.; As Reqd  
 Ford; F Pickup; 1997; V-8 5.4 Eng.; By Pass Valve Washers (Front); W/E4OD Trans.; As Reqd  
 Ford; F Pickup; 1997; V-8 5.8 Eng.; By Pass Valve Washers (Front); As Reqd  
 Ford; F Pickup; 1997; V-8 7.3 Diesel Eng.; By Pass Valve Washers (Front); As Reqd  
 Ford; F Pickup; 1997; V-8 7.5 Eng.; By Pass Valve Washers (Front); As Reqd  
 Ford; Super Duty Pickup; 2002-1999; V-8 5.4 Eng.; By Pass Valve Washers (Front); As Reqd  
 Ford; Super Duty Pickup; 2002-1999; V-8 7.3 Diesel Eng.; By Pass Valve Washers (Front); W/.535 I.D. Washer; As Reqd  
 Ford; Super Duty Pickup; 1997; V-8 7.3 Diesel Eng.; By Pass Valve Washers (Front); As Reqd  
 Ford; Super Duty Pickup; 2002-1999; V-10 6.8 Eng.; By Pass Valve Washers (Front); As Reqd  
 Ford; Super Duty Van; 2003-1999; V-8 5.4 Eng.; By Pass Valve Washers (Front); W/4R100 Trans.; As Reqd  
 Ford; Super Duty Van; 1998; V-8 5.4 Eng.; By Pass Valve Washers (Front); W/E4OD/4R100 Trans.; As Reqd  
 Ford; Super Duty Van; 1997; V-8 5.4 Eng.; By Pass Valve Washers (Front); W/E4OD Trans.; As Reqd  
 Ford; Super Duty Van; 2003-1997; V-8 7.3 Diesel Eng.; By Pass Valve Washers (Front); As Reqd  
 Ford; Super Duty Van; 2003-1997; V-10 6.8 Eng.; By Pass Valve Washers (Front); As Reqd  
 Linc; Navigator; 2002-1998; V-8 5.4 Eng.; By Pass Valve Washers (Front); As Reqd

### A63106

Ford; E Van; 1996-1988; 6-Cyl. 4.9 Eng.; By Pass Valve Washers (Rear); W/.668 I.D. Washer; W/4-Spd AT; As Reqd  
 Ford; E Van; 1996-1988; V-8 5.0 Eng.; By Pass Valve Washers (Rear); W/.668 I.D. Washer; W/4-Spd AT; As Reqd  
 Ford; E Van; 2003-1999; V-8 5.4 Eng.; By Pass Valve Washers (Rear); W/4R100 Trans.; As Reqd  
 Ford; E Van; 1998-1997; V-8 5.4 Eng.; By Pass Valve Washers (Rear); W/E4OD/4R100 Trans.; As Reqd  
 Ford; E Van; 1996-1988; V-8 5.8 Eng.; By Pass Valve Washers (Rear); W/.668 I.D. Washer; W/4-Spd AT; As Reqd  
 Ford; E Van; 1998-1997; V-8 7.3 Diesel Eng.; By Pass Valve Washers (Rear); As Reqd  
 Ford; E Van; 1996-1988; V-8 7.3 Diesel Eng.; By Pass Valve Washers (Rear); W/.668 I.D. Washer; W/4-Spd AT; As Reqd  
 Ford; E Van; 1996-1988; V-8 7.5 Eng.; By Pass Valve Washers (Rear); W/.668 I.D. Washer; W/4-Spd AT; As Reqd  
 Ford; E Van; 1998-1997; V-10 6.8 Eng.; By Pass Valve Washers (Rear); As Reqd  
 Ford; Excursion; 2002-2000; V-8 5.4 Eng.; By Pass Valve Washers (Rear); As Reqd  
 Ford; Excursion; 2002; V-8 7.3 Diesel Eng.; By Pass Valve Washers (Rear); W/.668 I.D. Washer; As Reqd  
 Ford; Excursion; 2001; V-8 7.3 Diesel Eng.; By Pass Valve Washers (Rear); As Reqd  
 Ford; Excursion; 2000; V-8 7.3 Diesel Eng.; By Pass Valve Washers (Rear); W/.668 I.D. Washer; As Reqd  
 Ford; Excursion; 2002-2000; V-10 6.8 Eng.; By Pass Valve Washers (Rear); As Reqd  
 Ford; Expedition; 2002-1997; V-8 5.4 Eng.; By Pass Valve Washers (Rear); As Reqd  
 Ford; F Pickup; 2002-1998; V-8 5.4 Eng.; By Pass Valve Washers (Rear); W/4R100 Trans.; As Reqd  
 Ford; F Pickup; 1997; V-8 5.4 Eng.; By Pass Valve Washers (Rear); W/E4OD Trans.; As Reqd  
 Ford; F Pickup; 1997; V-8 5.8 Eng.; By Pass Valve Washers (Rear); As Reqd  
 Ford; F Pickup; 1997; V-8 7.3 Diesel Eng.; By Pass Valve Washers (Rear); As Reqd  
 Ford; F Pickup; 1997; V-8 7.5 Eng.; By Pass Valve Washers (Rear); As Reqd  
 Ford; Super Duty Pickup; 2002-1999; V-8 5.4 Eng.; By Pass Valve Washers (Rear); As Reqd  
 Ford; Super Duty Pickup; 2002-1999; V-8 7.3 Diesel Eng.; By Pass Valve Washers (Rear); W/.668 I.D. Washer; As Reqd  
 Ford; Super Duty Pickup; 1997; V-8 7.3 Diesel Eng.; By Pass Valve Washers (Rear); As Reqd  
 Ford; Super Duty Pickup; 2002-1999; V-10 6.8 Eng.; By Pass Valve Washers (Rear); As Reqd  
 Ford; Super Duty Van; 2003-1999; V-8 5.4 Eng.; By Pass Valve Washers (Rear); W/4R100 Trans.; As Reqd  
 Ford; Super Duty Van; 1998; V-8 5.4 Eng.; By Pass Valve Washers (Rear); W/E4OD/4R100 Trans.; As Reqd  
 Ford; Super Duty Van; 1997; V-8 5.4 Eng.; By Pass Valve Washers (Rear); W/E4OD Trans.; As Reqd  
 Ford; Super Duty Van; 2003-1997; V-8 7.3 Diesel Eng.; By Pass Valve Washers (Rear); As Reqd  
 Ford; Super Duty Van; 2003-1997; V-10 6.8 Eng.; By Pass Valve Washers (Rear); As Reqd  
 Linc; Navigator; 2002-1998; V-8 5.4 Eng.; By Pass Valve Washers (Rear); As Reqd

### A63107

Ford; E Van; 1996-1988; 6-Cyl. 4.9 Eng.; Washer From Rad  
 Ford; E Van; 1996-1988; V-8 5.0 Eng.; Washer From Rad  
 Ford; E Van; 1996-1988; V-8 5.8 Eng.; Washer From Rad  
 Ford; E Van; 1996-1988; V-8 7.3 Diesel Eng.; Washer From Rad  
 Ford; E Van; 1996-1988; V-8 7.5 Eng.; Washer From Rad

### A63108

Cad; Deville; 2003-2001; V-8 4.6 Eng.; Outlet Seal From Rad (Lower)  
 Cad; Eldorado; 2002-2001; V-8 4.6 Eng.; Outlet Seal From Rad (Lower)  
 Cad; Seville; 2003-2001; V-8 4.6 Eng.; Outlet Seal From Rad (Lower)  
 Olds; Aurora; 2003-2001; V-8 4.0 Eng.; Outlet Seal From Rad (Lower)  
 Olds; Aurora; 1999-1995; V-8 4.0 Eng.; Outlet Seal From Rad (Lower)

### A63109

Dodge; Stealth; 1996-1995; V-6 3.0 Eng.; Banjo Washers; 8 Reqd  
 Dodge; Stealth; 1994-1992; V-6 3.0 Eng.; Banjo Washers (Aux. Cooler); 4 Reqd  
 Eagle; Talon; 1994-1993; 4-Cyl. 1.8 Eng.; Banjo Washers; 4 Reqd

# Numerical Listing - Oil Cooler Assemblies & End Fittings

## A63109 - Continued

Eagle; Talon; 1998-1995; 4-Cyl. 2.0 Eng.; Banjo Washers; W/Turbo; 4 Reqd  
 Eagle; Talon; 1994-1990; 4-Cyl. 2.0 Eng.; Banjo Washers; 4 Reqd  
 Ply; Laser; 1994-1990; 4-Cyl. 1.8 Eng.; Banjo Washers; 4 Reqd  
 Ply; Laser; 1994-1990; 4-Cyl. 2.0 Eng.; Banjo Washers; 4 Reqd

## A63110

Chev; Blazer Full Size; 1994-1993; V-8 5.7 Eng.; Wire Retainer (Connectors); As Reqd  
 Chev; Blazer Full Size; 1991-1987; V-8 6.2 Diesel Eng.; Wire Retainer (Connectors); As Reqd  
 Chev; Blazer Full Size; 1994; V-8 6.5 Diesel Eng.; Wire Retainer (Connectors); As Reqd  
 Chev; C&K Pickup; 1995-1993; V-8 5.7 Eng.; Wire Retainer (Connectors); As Reqd  
 Chev; C&K Pickup; 1995-1993; V-8 6.5 Diesel Eng.; Wire Retainer (Connectors); As Reqd  
 Chev; C&K Pickup; 1995-1993; V-8 7.4 Eng.; Wire Retainer (Connectors); As Reqd  
 Chev; Suburban; 1995-1993; V-8 5.7 Eng.; Wire Retainer (Connectors); As Reqd  
 Chev; Suburban; 1995-1994; V-8 6.5 Diesel Eng.; Wire Retainer (Connectors); As Reqd  
 Chev; Suburban; 1995-1993; V-8 7.4 Eng.; Wire Retainer (Connectors); As Reqd  
 Chev; Tahoe; 1995; V-8 5.7 Eng.; Wire Retainer (Connectors); As Reqd  
 Chev; Tahoe; 1995; V-8 6.5 Diesel Eng.; Wire Retainer (Connectors); As Reqd  
 GMC; C&K Pickup; 1995-1993; V-8 5.7 Eng.; Wire Retainer (Connectors); As Reqd  
 GMC; C&K Pickup; 1995-1993; V-8 6.5 Diesel Eng.; Wire Retainer (Connectors); As Reqd  
 GMC; C&K Pickup; 1995-1993; V-8 7.4 Eng.; Wire Retainer (Connectors); As Reqd  
 GMC; Jimmy Full Size; 1991-1987; V-8 6.2 Diesel Eng.; Wire Retainer (Connectors); As Reqd  
 GMC; Suburban; 1995-1993; V-8 5.7 Eng.; Wire Retainer (Connectors); As Reqd  
 GMC; Suburban; 1995-1994; V-8 6.5 Diesel Eng.; Wire Retainer (Connectors); As Reqd  
 GMC; Suburban; 1995-1993; V-8 7.4 Eng.; Wire Retainer (Connectors); As Reqd  
 GMC; Yukon; 1995-1993; V-8 5.7 Eng.; Wire Retainer (Connectors); As Reqd  
 GMC; Yukon; 1995-1994; V-8 6.5 Diesel Eng.; Wire Retainer (Connectors); As Reqd

## A64000

Chev; G Van; 1991-1985; V-8 5.0 Eng.; Inlet Hose (Upper) To Oil Filter Adapter  
 Chev; G Van; 1991-1985; V-8 5.7 Eng.; Inlet Hose (Upper) To Oil Filter Adapter  
 GMC; G Van; 1991-1985; V-8 5.0 Eng.; Inlet Hose (Upper) To Oil Filter Adapter  
 GMC; G Van; 1991-1985; V-8 5.7 Eng.; Inlet Hose (Upper) To Oil Filter Adapter

## A64001

Chev; G Van; 1991-1985; V-8 5.0 Eng.; Outlet Hose (Lower) To Oil Filter Adapter  
 Chev; G Van; 1991-1985; V-8 5.7 Eng.; Outlet Hose (Lower) To Oil Filter Adapter  
 GMC; G Van; 1991-1985; V-8 5.0 Eng.; Outlet Hose (Lower) To Oil Filter Adapter  
 GMC; G Van; 1991-1985; V-8 5.7 Eng.; Outlet Hose (Lower) To Oil Filter Adapter

## A64002

Chev; G Van; 1996-1992; V-8 5.0 Eng.; Inlet Hose (Upper) To Oil Filter Adapter  
 Chev; G Van; 1996-1992; V-8 5.0 Eng.; Outlet Hose (Lower) To Oil Filter Adapter  
 Chev; G Van; 1996-1992; V-8 5.7 Eng.; Inlet Hose (Upper) To Oil Filter Adapter  
 Chev; G Van; 1996-1992; V-8 5.7 Eng.; Outlet Hose (Lower) To Oil Filter Adapter  
 GMC; G Van; 1995-1992; V-8 5.0 Eng.; Inlet Hose (Upper) To Oil Filter Adapter  
 GMC; G Van; 1995-1992; V-8 5.0 Eng.; Outlet Hose (Lower) To Oil Filter Adapter

## A64002 - Continued

GMC; G Van; 1996-1992; V-8 5.7 Eng.; Inlet Hose (Upper) To Oil Filter Adapter  
 GMC; G Van; 1996-1992; V-8 5.7 Eng.; Outlet Hose (Lower) To Oil Filter Adapter

## B61009

Buick; Lesabre; 1997; V-6 3.8 Eng.; Outlet From Rad (Lower); 2-18 & Older  
 Buick; Lesabre; 1996; V-6 3.8 Eng.; Outlet From Rad (Lower)  
 Buick; Park Ave.; 1996; V-6 3.8 Eng.; Outlet (Lower)  
 Olds; Eighty Eight; 1997; V-6 3.8 Eng.; Outlet From Rad (Lower); 2-18 & Older  
 Olds; Eighty Eight; 1996; V-6 3.8 Eng.; Outlet (Lower)  
 Olds; Ninety Eight; 1996; V-6 3.8 Eng.; Outlet (Lower)  
 Olds; Regency; 1997; V-6 3.8 Eng.; Outlet From Rad (Lower); 2-18 & Older  
 Pont; Bonneville; 1997; V-6 3.8 Eng.; Outlet From Rad (Lower); 2-18 & Older  
 Pont; Bonneville; 1996; V-6 3.8 Eng.; Outlet (Lower)  
 Pont; Bonneville; 1996; V-6 3.8 Eng.; Outlet From Rad (Lower)

## B61010

Chry; Concorde; 1996-1993; V-6 3.3 Eng.; Inlet (Upper)  
 Chry; Concorde; 1997-1993; V-6 3.5 Eng.; Inlet (Upper)  
 Chry; LHS; 1997-1994; V-6 3.5 Eng.; Inlet (Upper)  
 Chry; New Yorker; 1996-1994; V-6 3.5 Eng.; Inlet (Upper)  
 Dodge; Intrepid; 1997-1993; V-6 3.3 Eng.; Inlet (Upper)  
 Dodge; Intrepid; 1997-1993; V-6 3.5 Eng.; Inlet (Upper)  
 Eagle; Vision; 1996-1993; V-6 3.3 Eng.; Inlet (Upper)  
 Eagle; Vision; 1997; V-6 3.3 (Canada) Eng.; Inlet (Upper)  
 Eagle; Vision; 1997-1993; V-6 3.5 Eng.; Inlet (Upper)

## B61011

Chry; Concorde; 1996-1993; V-6 3.3 Eng.; Outlet (Lower)  
 Chry; Concorde; 1997-1993; V-6 3.5 Eng.; Outlet (Lower)  
 Chry; LHS; 1997-1994; V-6 3.5 Eng.; Outlet (Lower)  
 Chry; New Yorker; 1996-1994; V-6 3.5 Eng.; Outlet (Lower)  
 Dodge; Intrepid; 1997-1993; V-6 3.3 Eng.; Outlet (Lower)  
 Dodge; Intrepid; 1997-1993; V-6 3.5 Eng.; Outlet (Lower)  
 Eagle; Vision; 1996-1993; V-6 3.3 Eng.; Outlet (Lower)  
 Eagle; Vision; 1997; V-6 3.3 (Canada) Eng.; Outlet (Lower)  
 Eagle; Vision; 1997-1993; V-6 3.5 Eng.; Outlet (Lower)

## B61012

Ford; Crown Victoria; 1997-1996; V-8 4.6 Eng.; Outlet To Trans. (Upper); W/Aux. Cooler  
 Linc; Town Car; 1997-1996; V-8 4.6 Eng.; Outlet To Trans. (Upper)  
 Merc; Grand Marquis; 1997-1996; V-8 4.6 Eng.; Outlet To Trans. (Upper); W/Aux. Cooler

## B61013

Chev; Lumina; 1992-1991; V-6 3.4 Eng.; Tube Nut; W/4-Spd Trans.; 2 Reqd  
 Ford; Taurus; 1996; V-6 3.0 Eng.; Outlet (Upper); W/O Aux. Cooler; W/AX4S Trans.  
 Merc; Sable; 1996; V-6 3.0 Eng.; Outlet (Upper); W/O Aux. Cooler; W/AX4S Trans.

## B61016

Ford; Crown Victoria; 2003-1998; V-8 4.6 Eng.; Inlet & Outlet Assy  
 Linc; Town Car; 2003-1998; V-8 4.6 Eng.; Inlet & Outlet Assy  
 Merc; Grand Marquis; 2003-1998; V-8 4.6 Eng.; Inlet & Outlet Assy

## B61018

Dodge; Ram Pickup; 1999-1994; V-8 5.2 Eng.; Outlet (Lower)  
 Dodge; Ram Pickup; 1999-1994; V-8 5.9 Eng.; Outlet (Lower)

## B61020

Dodge; Ram Pickup; 2002-1994; V-10 8.0 Eng.; Outlet (Lower)

## B61024

Dodge; B Van; 2003-2000; V-6 3.9 Eng.; Outlet (Driver Side); W/4-Spd Trans.  
 Dodge; B Van; 2003-2000; V-8 5.2 Eng.; Outlet (Driver Side); W/4-Spd Trans.

## Numerical Listing - Oil Cooler Assemblies & End Fittings

### B61024 - Continued

Dodge; B Van; 1999-1998; V-8 5.2 Eng.; Outlet (Driver Side)  
 Dodge; B Van; 2003-2000; V-8 5.9 Eng.; Outlet (Driver Side); W/4-Spd Trans.  
 Dodge; B Van; 1999-1998; V-8 5.9 Eng.; Outlet (Driver Side)

### B61025

Chev; C&K Pickup; 2000-1996; V-8 7.4 Eng.; Aux. Cooler Inlet (Pass. Side); Exc 3500HD  
 Chev; Suburban; 1999-1997; V-8 7.4 Eng.; Aux. Cooler Inlet (Pass. Side)  
 GMC; C&K Pickup; 2000-1996; V-8 7.4 Eng.; Aux. Cooler Inlet (Pass. Side); Exc 3500HD  
 GMC; Suburban; 1999-1996; V-8 7.4 Eng.; Aux. Cooler Inlet (Pass. Side)

### B61026

Chev; C&K Pickup; 2000-1997; V-8 7.4 Eng.; Aux. Cooler Outlet (Driver Side); Exc 3500HD  
 Chev; Suburban; 1999-1997; V-8 7.4 Eng.; Aux. Cooler Outlet (Driver Side)  
 Chev; Suburban; 1996; V-8 7.4 Eng.; Aux. Cooler Inlet (Pass. Side)  
 GMC; C&K Pickup; 2000-1997; V-8 7.4 Eng.; Aux. Cooler Outlet (Driver Side); Exc 3500HD  
 GMC; Suburban; 1999-1997; V-8 7.4 Eng.; Aux. Cooler Outlet (Driver Side)

### B61029

Chev; C&K Pickup; 2000-1997; V-8 5.7 Eng.; Aux. Cooler Outlet (Driver Side); Exc 3500HD; W/17-Bolt Trans. Pan (MT1)  
 Chev; Suburban; 1999-1997; V-8 5.7 Eng.; Aux. Cooler Outlet (Driver Side); W/17-Bolt Trans. Pan (MT1)  
 GMC; C&K Pickup; 2000-1997; V-8 5.7 Eng.; Aux. Cooler Outlet (Driver Side); Exc 3500HD; W/17-Bolt Trans. Pan (MT1)  
 GMC; Suburban; 1999-1997; V-8 5.7 Eng.; Aux. Cooler Outlet (Driver Side); W/17-Bolt Trans. Pan (MT1)  
 GMC; Yukon; 1999-1997; V-8 5.7 Eng.; Aux. Cooler Outlet (Driver Side); W/17-Bolt Trans. Pan (MT1)

### B61032

Buick; Electra; 1990-1988; V-6 3.8 Eng.; Inlet Tube From Rad (Upper); W/O Aux. Cooler  
 Buick; Electra; 1989-1988; V-8 5.0 Eng.; Inlet Tube From Rad (Upper); W/O Aux. Cooler  
 Buick; Lesabre; 1990-1988; V-6 3.8 Eng.; Inlet Tube From Rad (Upper); W/O Aux. Cooler  
 Buick; Lesabre; 1990-1988; V-8 5.0 Eng.; Inlet Tube From Rad (Upper); W/O Aux. Cooler  
 Olds; Delta 88; 1988; V-6 3.8 Eng.; Inlet Tube From Rad (Upper); W/O Aux. Cooler  
 Olds; Eighty Eight; 1990-1989; V-6 3.8 Eng.; Inlet Tube From Rad (Upper); W/O Aux. Cooler  
 Olds; Ninety Eight; 1990-1988; V-6 3.8 Eng.; Inlet Tube From Rad (Upper); W/O Aux. Cooler  
 Pont; Bonneville; 1990-1988; V-6 3.8 Eng.; Inlet Tube From Rad (Upper); W/O Aux. Cooler

### B61033

Buick; Electra; 1990-1988; V-6 3.8 Eng.; Outlet Tube From Rad (Lower); W/O Aux. Cooler  
 Buick; Electra; 1989-1988; V-8 5.0 Eng.; Outlet Tube From Rad (Lower); W/O Aux. Cooler  
 Buick; Lesabre; 1990-1988; V-6 3.8 Eng.; Outlet Tube From Rad (Lower); W/O Aux. Cooler  
 Buick; Lesabre; 1990-1988; V-8 5.0 Eng.; Outlet Tube From Rad (Lower); W/O Aux. Cooler  
 Olds; Delta 88; 1988; V-6 3.8 Eng.; Outlet Tube From Rad (Lower); W/O Aux. Cooler  
 Olds; Eighty Eight; 1990-1989; V-6 3.8 Eng.; Outlet Tube From Rad (Lower); W/O Aux. Cooler  
 Olds; Ninety Eight; 1990-1988; V-6 3.8 Eng.; Outlet Tube From Rad (Lower); W/O Aux. Cooler  
 Pont; Bonneville; 1990-1988; V-6 3.8 Eng.; Outlet Tube From Rad (Lower); W/O Aux. Cooler

### B61036

Buick; Electra; 1990-1988; V-6 3.8 Eng.; Inlet Hose From Rad (Upper); W/Aux. Cooler  
 Buick; Electra; 1989-1988; V-8 5.0 Eng.; Inlet Hose From Rad (Upper); W/Aux. Cooler  
 Buick; Lesabre; 1990-1988; V-6 3.8 Eng.; Inlet Hose From Rad (Upper); W/Aux. Cooler

### B61036 - Continued

Buick; Lesabre; 1990-1988; V-8 5.0 Eng.; Inlet Hose From Rad (Upper); W/Aux. Cooler  
 Olds; Delta 88; 1988; V-6 3.8 Eng.; Inlet Hose From Rad (Upper); W/Aux. Cooler  
 Olds; Eighty Eight; 1990-1989; V-6 3.8 Eng.; Inlet Hose From Rad (Upper); W/Aux. Cooler  
 Olds; Ninety Eight; 1990-1988; V-6 3.8 Eng.; Inlet Hose From Rad (Upper); W/Aux. Cooler  
 Pont; Bonneville; 1990-1988; V-6 3.8 Eng.; Inlet Hose From Rad (Upper); W/Aux. Cooler

### B61037

Buick; Electra; 1990-1988; V-6 3.8 Eng.; Outlet Tube From Rad (Lower); W/Aux. Cooler  
 Buick; Electra; 1989-1988; V-8 5.0 Eng.; Outlet Tube From Rad (Lower); W/Aux. Cooler  
 Buick; Lesabre; 1990-1988; V-6 3.8 Eng.; Outlet Tube From Rad (Lower); W/Aux. Cooler  
 Buick; Lesabre; 1990-1988; V-8 5.0 Eng.; Outlet Tube From Rad (Lower); W/Aux. Cooler  
 Olds; Delta 88; 1988; V-6 3.8 Eng.; Outlet Tube From Rad (Lower); W/Aux. Cooler  
 Olds; Eighty Eight; 1990-1989; V-6 3.8 Eng.; Outlet Tube From Rad (Lower); W/Aux. Cooler  
 Olds; Ninety Eight; 1990-1988; V-6 3.8 Eng.; Outlet Tube From Rad (Lower); W/Aux. Cooler  
 Pont; Bonneville; 1990-1988; V-6 3.8 Eng.; Outlet Tube From Rad (Lower); W/Aux. Cooler

### B61038

Chry; Cirrus; 2000; V-6 2.5 Eng.; Inlet Hose (Pass. Side)  
 Chry; Cirrus; 1999-1995; V-6 2.5 Eng.; Inlet (Upper)  
 Chry; Sebring; 1999; V-6 2.5 Eng.; Inlet (Pass. Side); Convertible  
 Chry; Sebring; 1998-1997; V-6 2.5 Eng.; Inlet (Driver Side); Convertible  
 Chry; Sebring; 1996-1995; V-6 2.5 Eng.; Inlet (Upper)  
 Dodge; Stratus; 2000; V-6 2.5 Eng.; Inlet Hose (Pass. Side)  
 Dodge; Stratus; 1999-1995; V-6 2.5 Eng.; Inlet (Upper)

### B61042

Chev; Blazer; 2004-1996; V-6 4.3 Eng.; Inlet (Lower)  
 Chev; S Pickup; 2001-1996; V-6 4.3 Eng.; Inlet (Lower)  
 GMC; Jimmy; 2001-1996; V-6 4.3 Eng.; Inlet (Lower)  
 GMC; Jimmy; 2004-2002; V-6 4.3 (Canada) Eng.; Inlet (Lower)  
 GMC; Sonoma; 2001-1996; V-6 4.3 Eng.; Inlet (Lower)  
 Olds; Bravada; 2001-1996; V-6 4.3 Eng.; Inlet (Lower)

### B61043

Chev; Blazer; 2004-1996; V-6 4.3 Eng.; Outlet (Upper)  
 Chev; S Pickup; 2001-1996; V-6 4.3 Eng.; Outlet (Upper)  
 GMC; Jimmy; 2001-1996; V-6 4.3 Eng.; Outlet (Upper)  
 GMC; Jimmy; 2004-2002; V-6 4.3 (Canada) Eng.; Outlet (Upper)  
 GMC; Sonoma; 2001-1996; V-6 4.3 Eng.; Outlet (Upper)  
 Olds; Bravada; 2001-1996; V-6 4.3 Eng.; Outlet (Upper)

### B61046

Ford; Taurus; 1996; V-6 3.0 Eng.; Inlet (Lower); W/O Aux. Cooler; W/AX4S Trans.  
 Merc; Sable; 1996; V-6 3.0 Eng.; Inlet (Lower); W/O Aux. Cooler; W/AX4S Trans.

### B61047

Ford; Excursion; 2005-2000; V-8 5.4 Eng.; Inlet To Trans. (Rear)  
 Ford; Excursion; 2005-2000; V-10 6.8 Eng.; Inlet To Trans. (Rear)  
 Ford; Super Duty Pickup; 2002-1999; V-8 5.4 Eng.; Inlet To Trans. (Rear)  
 Ford; Super Duty Pickup; 2002-1999; V-10 6.8 Eng.; Inlet To Trans. (Rear)

### B61048

Dodge; Ram Pickup; 1995-1994; V-8 5.2 Eng.; Inlet Tube To Trans. (Upper); W/Sensor  
 Dodge; Ram Pickup; 1995-1994; V-8 5.9 Eng.; Inlet Tube To Trans. (Upper); W/Sensor

### B61050

Dodge; Ram Pickup; 2002-1994; 6-Cyl. 5.9 Diesel Eng.; Oil Cooler Outlet Hose To Trans. (Rear)



# Numerical Listing - Oil Cooler Assemblies & End Fittings

## B61051

Jeep; Grand Cherokee; 1995-1994; 6-Cyl. 4.0 Eng.; Aux. Cooler Outlet Tube (Lower)

## B61053

Chev; Lumina APV; 1996; V-6 3.4 Eng.; Inlet From Rad (Upper)  
 Chev; Lumina APV; 1995-1992; V-6 3.8 Eng.; Inlet From Rad (Upper); W/O Aux. Cooler  
 Olds; Silhouette; 1996; V-6 3.4 Eng.; Inlet From Rad (Upper)  
 Olds; Silhouette; 1995-1992; V-6 3.8 Eng.; Inlet From Rad (Upper); W/O Aux. Cooler  
 Pont; Trans Sport; 1996; V-6 3.4 Eng.; Outlet From Rad (Upper)  
 Pont; Trans Sport; 1995-1992; V-6 3.8 Eng.; Inlet From Rad (Upper); W/O Aux. Cooler

## B61054

Chev; Lumina APV; 1995-1992; V-6 3.8 Eng.; Inlet From Rad (Lower); W/Aux. Cooler  
 Olds; Silhouette; 1995-1992; V-6 3.8 Eng.; Inlet From Rad (Lower); W/Aux. Cooler  
 Pont; Trans Sport; 1995-1992; V-6 3.8 Eng.; Inlet From Rad (Lower); W/Aux. Cooler

## B61055

Cad; Escalade; 2000-1999; V-8 5.7 Eng.; Outlet (Lower); W/O Aux. Cooler  
 Chev; C&K Pickup; 1999-1998; V-8 5.0 Eng.; Outlet (Lower); W/140A. Gen.  
 Chev; C&K Pickup; 2000-1998; V-8 5.7 Eng.; Outlet (Lower); W/O Aux. Cooler; W/16-Bolt Trans. Pan (M30)  
 Chev; Suburban; 1999-1998; V-8 5.7 Eng.; Outlet (Lower); W/O Aux. Cooler; W/16-Bolt Trans. Pan (M30)  
 Chev; Tahoe; 2000-1998; V-8 5.7 Eng.; Outlet (Lower); W/O Aux. Cooler  
 GMC; C&K Pickup; 1999-1998; V-8 5.0 Eng.; Outlet (Lower); W/140A. Gen.  
 GMC; C&K Pickup; 2000-1998; V-8 5.7 Eng.; Outlet (Lower); W/O Aux. Cooler; W/16-Bolt Trans. Pan (M30)  
 GMC; Suburban; 1999-1998; V-8 5.7 Eng.; Outlet (Lower); W/O Aux. Cooler; W/16-Bolt Trans. Pan (M30)  
 GMC; Yukon; 2000; V-8 5.7 Eng.; Outlet (Lower); W/O Aux. Cooler  
 GMC; Yukon; 1999-1998; V-8 5.7 Eng.; Outlet (Lower); W/O Aux. Cooler; W/16-Bolt Trans. Pan (M30)

## B61056

Cad; Escalade; 2000-1999; V-8 5.7 Eng.; Aux. Cooler Outlet (Pass. Side)  
 Chev; C&K Pickup; 2000-1998; V-8 5.7 Eng.; Aux. Cooler Inlet (Pass. Side); Exc 3500HD; W/16-Bolt Trans. Pan (M30)  
 Chev; Suburban; 1999-1998; V-8 5.7 Eng.; Aux. Cooler Inlet (Pass. Side); W/16-Bolt Trans. Pan (M30)  
 Chev; Tahoe; 2000-1998; V-8 5.7 Eng.; Aux. Cooler Inlet (Pass. Side)  
 GMC; C&K Pickup; 2000-1998; V-8 5.7 Eng.; Aux. Cooler Inlet (Pass. Side); Exc 3500HD; W/16-Bolt Trans. Pan (M30)  
 GMC; Suburban; 1999-1998; V-8 5.7 Eng.; Aux. Cooler Inlet (Pass. Side); W/16-Bolt Trans. Pan (M30)  
 GMC; Yukon; 2000; V-8 5.7 Eng.; Aux. Cooler Inlet (Pass. Side)  
 GMC; Yukon; 1999-1998; V-8 5.7 Eng.; Aux. Cooler Inlet (Pass. Side); W/16-Bolt Trans. Pan (M30)

## B61057

Cad; Escalade; 2000-1999; V-8 5.7 Eng.; Inlet Tube (Upper); W/O Aux. Cooler  
 Chev; C&K Pickup; 1999-1998; V-8 5.0 Eng.; Inlet (Upper); W/140A. Gen.  
 Chev; C&K Pickup; 2000-1998; V-8 5.7 Eng.; Inlet (Upper); W/O Aux. Cooler; W/16-Bolt Trans. Pan (M30)  
 Chev; Suburban; 1999-1998; V-8 5.7 Eng.; Inlet (Upper); W/O Aux. Cooler; W/16-Bolt Trans. Pan (M30)  
 Chev; Tahoe; 2000-1998; V-8 5.7 Eng.; Inlet (Upper); W/O Aux. Cooler  
 GMC; C&K Pickup; 1999-1998; V-8 5.0 Eng.; Inlet (Upper); W/140A. Gen.  
 GMC; C&K Pickup; 2000-1998; V-8 5.7 Eng.; Inlet (Upper); W/O Aux. Cooler; W/16-Bolt Trans. Pan (M30)  
 GMC; Suburban; 1999-1998; V-8 5.7 Eng.; Inlet (Upper); W/O Aux. Cooler; W/16-Bolt Trans. Pan (M30)  
 GMC; Yukon; 2000; V-8 5.7 Eng.; Inlet (Upper); W/O Aux. Cooler  
 GMC; Yukon; 1999-1998; V-8 5.7 Eng.; Inlet (Upper); W/O Aux. Cooler; W/16-Bolt Trans. Pan (M30)

## B61058

Cad; Escalade; 2000-1999; V-8 5.7 Eng.; Aux. Cooler Inlet (Driver Side)  
 Chev; C&K Pickup; 2000-1998; V-8 5.7 Eng.; Aux. Cooler Outlet (Driver Side); Exc 3500HD; W/16-Bolt Trans. Pan (M30)

## B61058 - Continued

Chev; Suburban; 1999-1998; V-8 5.7 Eng.; Aux. Cooler Outlet (Driver Side); W/16-Bolt Trans. Pan (M30)  
 Chev; Tahoe; 2000-1998; V-8 5.7 Eng.; Aux. Cooler Outlet (Driver Side)  
 GMC; C&K Pickup; 2000-1998; V-8 5.7 Eng.; Aux. Cooler Outlet (Driver Side); Exc 3500HD; W/16-Bolt Trans. Pan (M30)  
 GMC; Suburban; 1999-1998; V-8 5.7 Eng.; Aux. Cooler Outlet (Driver Side); W/16-Bolt Trans. Pan (M30)  
 GMC; Yukon; 2000; V-8 5.7 Eng.; Aux. Cooler Outlet (Driver Side)  
 GMC; Yukon; 1999-1998; V-8 5.7 Eng.; Aux. Cooler Outlet (Driver Side); W/16-Bolt Trans. Pan (M30)

## B61059

Chev; C&K Pickup; 1998; V-6 4.3 Eng.; Inlet (Upper)  
 Chev; C&K Pickup; 1999-1998; V-8 5.0 Eng.; Inlet (Upper); W/O 140A. Gen.  
 GMC; C&K Pickup; 1998; V-6 4.3 Eng.; Inlet (Upper)  
 GMC; C&K Pickup; 1999-1998; V-8 5.0 Eng.; Inlet (Upper); W/O 140A. Gen.

## B61060

Chev; C&K Pickup; 1998; V-6 4.3 Eng.; Outlet (Lower)  
 Chev; C&K Pickup; 1999-1998; V-8 5.0 Eng.; Outlet (Lower); W/O 140A. Gen.  
 GMC; C&K Pickup; 1998; V-6 4.3 Eng.; Outlet (Lower)  
 GMC; C&K Pickup; 1999-1998; V-8 5.0 Eng.; Outlet (Lower); W/O 140A. Gen.

## B61064

Chry; Town & Country Van; 1993; V-6 3.3 Eng.; Outlet Tube; W/Air Cooled Trans. Cooler  
 Chry; Town & Country Van; 1995-1994; V-6 3.8 Eng.; Outlet Tube; W/Air Cooled Trans. Cooler  
 Dodge; Caravan; 1995-1993; 4-Cyl. 2.5 Eng.; Outlet Tube; W/Air Cooled Trans. Cooler  
 Dodge; Caravan; 1995-1993; V-6 3.0 Eng.; Outlet Tube; W/Air Cooled Trans. Cooler  
 Dodge; Caravan; 1995-1993; V-6 3.3 Eng.; Outlet Tube; W/Air Cooled Trans. Cooler  
 Dodge; Grand Caravan; 1995-1993; V-6 3.0 Eng.; Outlet Tube; W/Air Cooled Trans. Cooler  
 Dodge; Grand Caravan; 1995-1993; V-6 3.3 Eng.; Outlet Tube; W/Air Cooled Trans. Cooler  
 Dodge; Grand Caravan; 1995-1994; V-6 3.8 Eng.; Outlet Tube; W/Air Cooled Trans. Cooler  
 Ply; Grand Voyager; 1995-1993; V-6 3.0 Eng.; Outlet Tube; W/Air Cooled Trans. Cooler  
 Ply; Grand Voyager; 1995-1993; V-6 3.3 Eng.; Outlet Tube; W/Air Cooled Trans. Cooler  
 Ply; Grand Voyager; 1995-1994; V-6 3.8 Eng.; Outlet Tube; W/Air Cooled Trans. Cooler  
 Ply; Voyager; 1995-1993; 4-Cyl. 2.5 Eng.; Outlet Tube; W/Air Cooled Trans. Cooler  
 Ply; Voyager; 1995-1993; V-6 3.0 Eng.; Outlet Tube; W/Air Cooled Trans. Cooler  
 Ply; Voyager; 1995-1993; V-6 3.3 Eng.; Outlet Tube; W/Air Cooled Trans. Cooler

## B61065

Chry; Town & Country Van; 1998; V-6 3.3 Eng.; Rad Oil Cooler Inlet (Lower)  
 Chry; Town & Country Van; 1997-1996; V-6 3.3 Eng.; Rad Oil Cooler Inlet (Lower); W/Trlr Tow Pkg  
 Chry; Town & Country Van; 1998; V-6 3.8 Eng.; Rad Oil Cooler Inlet (Lower)  
 Chry; Town & Country Van; 1997-1996; V-6 3.8 Eng.; Rad Oil Cooler Inlet (Lower); W/Trlr Tow Pkg  
 Dodge; Caravan; 1998; V-6 3.0 Eng.; Rad Oil Cooler Inlet (Lower); W/3-Spd Trans.  
 Dodge; Caravan; 1998; V-6 3.3 Eng.; Rad Oil Cooler Inlet (Lower)  
 Dodge; Caravan; 1997; V-6 3.3 Eng.; Rad Oil Cooler Inlet (Lower); W/Trlr Tow Pkg  
 Dodge; Caravan; 1996; V-6 3.3 Eng.; Rad Oil Cooler Outlet (Lower); W/Trlr Tow Pkg  
 Dodge; Caravan; 1998; V-6 3.8 Eng.; Rad Oil Cooler Inlet (Lower)  
 Dodge; Caravan; 1997; V-6 3.8 Eng.; Rad Oil Cooler Inlet (Lower); W/Trlr Tow Pkg  
 Dodge; Caravan; 1996; V-6 3.8 Eng.; Rad Oil Cooler Outlet (Lower); W/Trlr Tow Pkg  
 Dodge; Grand Caravan; 1998; V-6 3.0 Eng.; Rad Oil Cooler Inlet (Lower); W/3-Spd Trans.  
 Dodge; Grand Caravan; 1998; V-6 3.3 Eng.; Rad Oil Cooler Inlet (Lower)

## Numerical Listing - Oil Cooler Assemblies & End Fittings

### B61065 - Continued

Dodge; Grand Caravan; 1997; V-6 3.3 Eng.; Rad Oil Cooler Inlet (Lower); W/Trlr Tow Pkg  
 Dodge; Grand Caravan; 1996; V-6 3.3 Eng.; Rad Oil Cooler Outlet (Lower); W/Trlr Tow Pkg  
 Dodge; Grand Caravan; 1998; V-6 3.8 Eng.; Rad Oil Cooler Inlet (Lower)  
 Dodge; Grand Caravan; 1997; V-6 3.8 Eng.; Rad Oil Cooler Inlet (Lower); W/Trlr Tow Pkg  
 Dodge; Grand Caravan; 1996; V-6 3.8 Eng.; Rad Oil Cooler Outlet (Lower); W/Trlr Tow Pkg  
 Ply; Grand Voyager; 1998; V-6 3.0 Eng.; Rad Oil Cooler Inlet (Lower); W/3-Spd Trans.  
 Ply; Grand Voyager; 1998; V-6 3.3 Eng.; Rad Oil Cooler Inlet (Lower)  
 Ply; Grand Voyager; 1997-1996; V-6 3.3 Eng.; Rad Oil Cooler Inlet (Lower); W/Trlr Tow Pkg  
 Ply; Grand Voyager; 1996; V-6 3.8 Eng.; Rad Oil Cooler Inlet (Lower); W/Trlr Tow Pkg  
 Ply; Grand Voyager; 1998; V-6 3.8 (Canada) Eng.; Rad Oil Cooler Inlet (Lower)  
 Ply; Grand Voyager; 1997; V-6 3.8 (Canada) Eng.; Rad Oil Cooler Inlet (Lower); W/Trlr Tow Pkg  
 Ply; Voyager; 1998; V-6 3.0 Eng.; Rad Oil Cooler Inlet (Lower); W/3-Spd Trans.  
 Ply; Voyager; 1998; V-6 3.3 Eng.; Rad Oil Cooler Inlet (Lower)  
 Ply; Voyager; 1997-1996; V-6 3.3 Eng.; Rad Oil Cooler Inlet (Lower); W/Trlr Tow Pkg  
 Ply; Voyager; 1996; V-6 3.8 Eng.; Rad Oil Cooler Inlet (Lower); W/Trlr Tow Pkg  
 Ply; Voyager; 1998; V-6 3.8 (Canada) Eng.; Rad Oil Cooler Inlet (Lower)  
 Ply; Voyager; 1997; V-6 3.8 (Canada) Eng.; Rad Oil Cooler Inlet (Lower); W/Trlr Tow Pkg

### B61066

Chry; Town & Country Van; 1998; V-6 3.3 Eng.; Rad Oil Cooler Supply (Upper)  
 Chry; Town & Country Van; 1997-1996; V-6 3.3 Eng.; Rad Oil Cooler Supply (Upper); W/Trlr Tow Pkg  
 Chry; Town & Country Van; 1998; V-6 3.8 Eng.; Rad Oil Cooler Supply (Upper)  
 Chry; Town & Country Van; 1997-1996; V-6 3.8 Eng.; Rad Oil Cooler Supply (Upper); W/Trlr Tow Pkg  
 Dodge; Caravan; 1998; V-6 3.0 Eng.; Rad Oil Cooler Supply (Upper); W/3-Spd Trans.  
 Dodge; Caravan; 1998; V-6 3.3 Eng.; Rad Oil Cooler Supply (Upper)  
 Dodge; Caravan; 1997; V-6 3.3 Eng.; Rad Oil Cooler Supply (Upper); W/Trlr Tow Pkg  
 Dodge; Caravan; 1996; V-6 3.3 Eng.; Rad Oil Cooler Inlet (Upper); W/Trlr Tow Pkg  
 Dodge; Caravan; 1998; V-6 3.8 Eng.; Rad Oil Cooler Supply (Upper)  
 Dodge; Caravan; 1997; V-6 3.8 Eng.; Rad Oil Cooler Supply (Upper); W/Trlr Tow Pkg  
 Dodge; Caravan; 1996; V-6 3.8 Eng.; Rad Oil Cooler Inlet (Upper); W/Trlr Tow Pkg  
 Dodge; Grand Caravan; 1998; V-6 3.0 Eng.; Rad Oil Cooler Supply (Upper); W/3-Spd Trans.  
 Dodge; Grand Caravan; 1998; V-6 3.3 Eng.; Rad Oil Cooler Supply (Upper)  
 Dodge; Grand Caravan; 1997; V-6 3.3 Eng.; Rad Oil Cooler Supply (Upper); W/Trlr Tow Pkg  
 Dodge; Grand Caravan; 1996; V-6 3.3 Eng.; Rad Oil Cooler Inlet (Upper); W/Trlr Tow Pkg  
 Dodge; Grand Caravan; 1998; V-6 3.8 Eng.; Rad Oil Cooler Supply (Upper)  
 Dodge; Grand Caravan; 1997; V-6 3.8 Eng.; Rad Oil Cooler Supply (Upper); W/Trlr Tow Pkg  
 Dodge; Grand Caravan; 1996; V-6 3.8 Eng.; Rad Oil Cooler Inlet (Upper); W/Trlr Tow Pkg  
 Ply; Grand Voyager; 1998; V-6 3.0 Eng.; Rad Oil Cooler Supply (Upper); W/3-Spd Trans.  
 Ply; Grand Voyager; 1998; V-6 3.3 Eng.; Rad Oil Cooler Supply (Upper)  
 Ply; Grand Voyager; 1997-1996; V-6 3.3 Eng.; Rad Oil Cooler Supply (Upper); W/Trlr Tow Pkg  
 Ply; Grand Voyager; 1996; V-6 3.8 Eng.; Rad Oil Cooler Supply (Upper); W/Trlr Tow Pkg  
 Ply; Grand Voyager; 1998; V-6 3.8 (Canada) Eng.; Rad Oil Cooler Supply (Upper)  
 Ply; Grand Voyager; 1997; V-6 3.8 (Canada) Eng.; Rad Oil Cooler Supply (Upper); W/Trlr Tow Pkg  
 Ply; Voyager; 1998; V-6 3.0 Eng.; Rad Oil Cooler Supply (Upper); W/3-Spd Trans.  
 Ply; Voyager; 1998; V-6 3.3 Eng.; Rad Oil Cooler Supply (Upper)  
 Ply; Voyager; 1997-1996; V-6 3.3 Eng.; Rad Oil Cooler Supply (Upper); W/Trlr Tow Pkg

### B61066 - Continued

Ply; Voyager; 1996; V-6 3.8 Eng.; Rad Oil Cooler Supply (Upper); W/Trlr Tow Pkg  
 Ply; Voyager; 1998; V-6 3.8 (Canada) Eng.; Rad Oil Cooler Supply (Upper)  
 Ply; Voyager; 1997; V-6 3.8 (Canada) Eng.; Rad Oil Cooler Supply (Upper); W/Trlr Tow Pkg

### B61067

Chry; Concorde; 2004-1998; V-6 2.7 Eng.; Outlet From Rad (Lower)  
 Dodge; Intrepid; 2004-1998; V-6 2.7 Eng.; Outlet From Rad (Lower)

### B61068

Chry; Concorde; 2004-1998; V-6 2.7 Eng.; Inlet From Rad (Upper)  
 Dodge; Intrepid; 2004-1998; V-6 2.7 Eng.; Inlet From Rad (Upper)

### B61073

Chry; Concorde; 1996-1993; V-6 3.3 Eng.; Aux. Cooler Outlet (Driver Side)  
 Chry; Concorde; 1997-1993; V-6 3.5 Eng.; Aux. Cooler Outlet (Driver Side)  
 Chry; LHS; 1997-1994; V-6 3.5 Eng.; Aux. Cooler Outlet (Driver Side)  
 Chry; New Yorker; 1996-1994; V-6 3.5 Eng.; Aux. Cooler Outlet (Driver Side)  
 Dodge; Intrepid; 1997-1993; V-6 3.3 Eng.; Aux. Cooler Outlet (Driver Side)  
 Dodge; Intrepid; 1997-1993; V-6 3.5 Eng.; Aux. Cooler Outlet (Driver Side)  
 Eagle; Vision; 1996-1993; V-6 3.3 Eng.; Aux. Cooler Outlet (Driver Side)  
 Eagle; Vision; 1997; V-6 3.3 (Canada) Eng.; Aux. Cooler Outlet (Driver Side)  
 Eagle; Vision; 1997-1993; V-6 3.5 Eng.; Aux. Cooler Outlet (Driver Side)

### B61100

Ford; Excursion; 2005-2001; V-8 5.4 Eng.; Outlet To Trans. (Front)  
 Ford; Excursion; 2005-2001; V-10 6.8 Eng.; Outlet To Trans. (Front)  
 Ford; Super Duty Pickup; 2002-2001; V-8 5.4 Eng.; Outlet To Trans. (Front)  
 Ford; Super Duty Pickup; 2002-2001; V-10 6.8 Eng.; Outlet To Trans. (Front)

### B61101

Dodge; Ram Pickup; 1996-1994; V-6 3.9 Eng.; Inlet Tube To Trans. (Upper); W/46RH Trans.

### B61103

Jeep; Grand Cherokee; 1996-1994; 6-Cyl. 4.0 Eng.; Outlet Tube From Rad (Upper); W/O Aux. Cooler

### B61104

Dodge; Dakota; 1999-1997; V-6 3.9 Eng.; Rad Outlet Tube To Aux. Cooler (Upper)  
 Dodge; Dakota; 1999-1997; V-8 5.2 Eng.; Rad Outlet Tube To Aux. Cooler (Upper)  
 Dodge; Dakota; 1999-1998; V-8 5.9 Eng.; Rad Outlet Tube To Aux. Cooler (Upper)  
 Dodge; Durango; 1999-1998; V-8 5.2 Eng.; Rad Outlet Tube To Aux. Cooler (Upper)  
 Dodge; Durango; 1999-1998; V-8 5.9 Eng.; Rad Outlet Tube To Aux. Cooler (Upper)

### B61105

Cad; Allante; 1993; V-8 4.6 Eng.; Inlet From Rad (Upper); W/Mid-Year ID Tag  
 Cad; Deville; 1995-1994; V-8 4.6 Eng.; Inlet From Rad (Upper)  
 Cad; Eldorado; 1995-1993; V-8 4.6 Eng.; Inlet From Rad (Upper)  
 Cad; Seville; 1995-1993; V-8 4.6 Eng.; Inlet From Rad (Upper)

### B61106

Cad; Deville; 1999-1996; V-8 4.6 Eng.; Inlet From Rad (Upper)  
 Cad; Eldorado; 2001; V-8 4.6 Eng.; Inlet From Rad (Upper); 1st Design; W/Threaded Fitting  
 Cad; Eldorado; 2000-1996; V-8 4.6 Eng.; Inlet From Rad (Upper)  
 Cad; Seville; 1999-1996; V-8 4.6 Eng.; Inlet From Rad (Upper)

### B61107

Chev; C&K Pickup; 2000-1997; V-8 6.5 Diesel Eng.; Aux. Cooler Outlet (Driver Side); Exc 3500HD

# Numerical Listing - Oil Cooler Assemblies & End Fittings

## B61107 - Continued

Chev; Silverado Pickup; 1999; V-8 6.5 Diesel Eng.; Aux. Cooler Outlet (Driver Side); Exc 3500HD  
 Chev; Suburban; 1999-1997; V-8 6.5 Diesel Eng.; Aux. Cooler Outlet (Driver Side)  
 Chev; Tahoe; 1999-1997; V-8 6.5 Diesel Eng.; Aux. Cooler Outlet (Driver Side)  
 GMC; C&K Pickup; 2000-1997; V-8 6.5 Diesel Eng.; Aux. Cooler Outlet (Driver Side); Exc 3500HD  
 GMC; Sierra Pickup; 1999; V-8 6.5 Diesel Eng.; Aux. Cooler Outlet (Driver Side); Exc 3500HD  
 GMC; Suburban; 1999-1997; V-8 6.5 Diesel Eng.; Aux. Cooler Outlet (Driver Side)  
 GMC; Yukon; 1997; V-8 6.5 Diesel Eng.; Aux. Cooler Outlet (Driver Side)

## B61108

Chev; C&K Pickup; 2000-1997; V-8 5.7 Eng.; Aux. Cooler Outlet (Driver Side); 3500HD  
 Chev; C&K Pickup; 2002-2001; V-8 6.5 Diesel Eng.; Aux. Cooler Outlet (Driver Side)  
 Chev; C&K Pickup; 2000-1997; V-8 6.5 Diesel Eng.; Aux. Cooler Outlet (Driver Side); 3500HD  
 Chev; C&K Pickup; 2000-1997; V-8 7.4 Eng.; Aux. Cooler Outlet (Driver Side); 3500HD  
 Chev; Silverado Pickup; 1999; V-8 6.5 Diesel Eng.; Aux. Cooler Outlet (Driver Side); 3500HD  
 GMC; C&K Pickup; 2000-1997; V-8 5.7 Eng.; Aux. Cooler Outlet (Driver Side); 3500HD  
 GMC; C&K Pickup; 2002-2001; V-8 6.5 Diesel Eng.; Aux. Cooler Outlet (Driver Side)  
 GMC; C&K Pickup; 2000-1997; V-8 6.5 Diesel Eng.; Aux. Cooler Outlet (Driver Side); 3500HD  
 GMC; C&K Pickup; 2000-1997; V-8 7.4 Eng.; Aux. Cooler Outlet (Driver Side); 3500HD  
 GMC; Sierra Pickup; 1999; V-8 6.5 Diesel Eng.; Aux. Cooler Outlet (Driver Side); 3500HD

## B61109

Chev; C&K Pickup; 1995-1994; V-8 5.7 Eng.; Aux. Cooler Outlet (Driver Side); 3500HD  
 Chev; C&K Pickup; 1995-1993; V-8 6.5 Diesel Eng.; Aux. Cooler Outlet (Driver Side); 3500HD  
 Chev; C&K Pickup; 1995-1993; V-8 7.4 Eng.; Aux. Cooler Outlet (Driver Side); 3500HD  
 GMC; C&K Pickup; 1995-1994; V-8 5.7 Eng.; Aux. Cooler Outlet (Driver Side); 3500HD  
 GMC; C&K Pickup; 1995-1993; V-8 6.5 Diesel Eng.; Aux. Cooler Outlet (Driver Side); 3500HD  
 GMC; C&K Pickup; 1995-1993; V-8 7.4 Eng.; Aux. Cooler Outlet (Driver Side); 3500HD

## B61110

Buick; Lesabre; 1995-1993; V-6 3.8 Eng.; Inlet From Rad (Upper); W/Aux. Cooler  
 Buick; Park Ave.; 1995-1994; V-6 3.8 Eng.; Inlet From Rad (Upper); W/Aux. Cooler  
 Olds; Eighty Eight; 1995-1993; V-6 3.8 Eng.; Inlet From Rad (Upper); W/Aux. Cooler  
 Olds; Ninety Eight; 1995-1993; V-6 3.8 Eng.; Inlet From Rad (Upper); W/Aux. Cooler  
 Pont; Bonneville; 1995-1993; V-6 3.8 Eng.; Inlet From Rad (Upper); W/Aux. Cooler

## B61111

Buick; Lesabre; 1999-1998; V-6 3.8 Eng.; Outlet From Rad (Lower)  
 Buick; Lesabre; 1997; V-6 3.8 Eng.; Outlet From Rad (Lower); 2-19 & Newer  
 Buick; Lesabre; 1995-1994; V-6 3.8 Eng.; Outlet From Rad (Lower)  
 Buick; Park Ave.; 1995-1994; V-6 3.8 Eng.; Outlet From Rad (Lower)  
 Olds; Eighty Eight; 1999-1998; V-6 3.8 Eng.; Outlet From Rad (Lower)  
 Olds; Eighty Eight; 1997; V-6 3.8 Eng.; Outlet From Rad (Lower); 2-19 & Newer  
 Olds; Eighty Eight; 1995-1994; V-6 3.8 Eng.; Outlet From Rad (Lower)  
 Olds; Ninety Eight; 1995-1993; V-6 3.8 Eng.; Outlet From Rad (Lower)  
 Olds; Regency; 1998; V-6 3.8 Eng.; Outlet From Rad (Lower)  
 Olds; Regency; 1997; V-6 3.8 Eng.; Outlet From Rad (Lower); 2-19 & Newer  
 Pont; Bonneville; 1999-1998; V-6 3.8 Eng.; Outlet From Rad (Lower)  
 Pont; Bonneville; 1997; V-6 3.8 Eng.; Outlet From Rad (Lower); 2-19 & Newer  
 Pont; Bonneville; 1995-1994; V-6 3.8 Eng.; Outlet From Rad (Lower)

## B61112

Buick; Lesabre; 1999-1998; V-6 3.8 Eng.; Inlet From Rad (Upper)  
 Buick; Lesabre; 1997; V-6 3.8 Eng.; Inlet From Rad (Upper); 2-19 & Newer  
 Buick; Lesabre; 1995-1993; V-6 3.8 Eng.; Inlet From Rad (Upper); W/O Aux. Cooler  
 Buick; Park Ave.; 1995-1994; V-6 3.8 Eng.; Inlet From Rad (Upper); W/O Aux. Cooler  
 Olds; Eighty Eight; 1999-1998; V-6 3.8 Eng.; Inlet From Rad (Upper)  
 Olds; Eighty Eight; 1997; V-6 3.8 Eng.; Inlet From Rad (Upper); 2-19 & Newer  
 Olds; Eighty Eight; 1995-1993; V-6 3.8 Eng.; Inlet From Rad (Upper); W/O Aux. Cooler  
 Olds; Ninety Eight; 1995-1993; V-6 3.8 Eng.; Inlet From Rad (Upper); W/O Aux. Cooler  
 Olds; Regency; 1998; V-6 3.8 Eng.; Inlet From Rad (Upper)  
 Olds; Regency; 1997; V-6 3.8 Eng.; Inlet From Rad (Upper); 2-19 & Newer  
 Pont; Bonneville; 1999-1998; V-6 3.8 Eng.; Inlet From Rad (Upper)  
 Pont; Bonneville; 1997; V-6 3.8 Eng.; Inlet From Rad (Upper); 2-19 & Newer  
 Pont; Bonneville; 1995-1993; V-6 3.8 Eng.; Inlet From Rad (Upper); W/O Aux. Cooler

## B61116

Dodge; Dakota; 1996-1994; V-6 3.9 Eng.; Rad Outlet Tube To Aux. Cooler (Upper)  
 Dodge; Dakota; 1996-1994; V-8 5.2 Eng.; Rad Outlet Tube To Aux. Cooler (Upper)

## B61117

Jeep; Cherokee; 2000-1994; 4-Cyl. 2.5 Eng.; Inlet Tube From Rad (Upper)  
 Jeep; Cherokee; 1993-1988; 4-Cyl. 2.5 Eng.; Outlet Tube From Rad (Upper)  
 Jeep; Cherokee; 2001-1988; 6-Cyl. 4.0 Eng.; Rad Inlet Tube (Upper)  
 Jeep; Comanche; 1992-1988; 4-Cyl. 2.5 Eng.; Outlet Tube From Rad (Upper)  
 Jeep; Comanche; 1992-1988; 6-Cyl. 4.0 Eng.; Inlet Tube From Rad (Upper)  
 Jeep; Wagoneer; 1990-1988; 6-Cyl. 4.0 Eng.; Inlet Tube From Rad (Upper)

## B61119

Buick; Skylark; 1995-1994; 4-Cyl. 2.3 Eng.; Inlet (Upper); W/4-Spd Trans.  
 Buick; Skylark; 1998-1996; 4-Cyl. 2.4 Eng.; Inlet (Upper)  
 Buick; Skylark; 1998-1994; V-6 3.1 Eng.; Inlet (Upper)  
 Chev; Beretta; 1994; 4-Cyl. 2.3 Eng.; Inlet (Upper); W/4-Spd Trans.  
 Chev; Beretta; 1996-1994; V-6 3.1 Eng.; Inlet (Upper)  
 Chev; Corsica; 1996-1994; V-6 3.1 Eng.; Inlet (Upper)  
 Olds; Achieva; 1995-1994; 4-Cyl. 2.3 Eng.; Inlet (Upper); W/4-Spd Trans.  
 Olds; Achieva; 1998-1997; 4-Cyl. 2.4 Eng.; Inlet (Upper)  
 Olds; Achieva; 1998-1997; V-6 3.1 Eng.; Inlet (Upper)  
 Olds; Achieva; 1995-1994; V-6 3.1 Eng.; Inlet (Upper)  
 Pont; Grand Am; 1995-1994; 4-Cyl. 2.3 Eng.; Inlet (Upper); W/4-Spd Trans.  
 Pont; Grand Am; 1998-1996; 4-Cyl. 2.4 Eng.; Inlet (Upper)  
 Pont; Grand Am; 1998-1994; V-6 3.1 Eng.; Inlet (Upper)

## B61120

Jeep; Cherokee; 1998-1994; 4-Cyl. 2.5 Eng.; Inlet Tube To Trans. (Front)

## B61122

Jeep; Cherokee; 1996-1988; 6-Cyl. 4.0 Eng.; Aux. Cooler Outlet (Upper) To Trans. (Rear)  
 Jeep; Comanche; 1992-1988; 6-Cyl. 4.0 Eng.; Outlet To Trans. (Rear)  
 Jeep; Wagoneer; 1990-1988; 6-Cyl. 4.0 Eng.; Outlet To Trans. (Rear)

## B61123

Dodge; B Van; 1997-1994; V-8 5.2 Eng.; Outlet (Driver Side); W/3-Spd Trans.  
 Dodge; B Van; 1997; V-8 5.9 Eng.; Outlet (Driver Side); W/3-Spd Trans.

## B61124

Dodge; B Van; 1997-1994; V-8 5.2 Eng.; Outlet (Driver Side); W/4-Spd Trans.  
 Dodge; B Van; 1997; V-8 5.9 Eng.; Outlet (Driver Side); W/4-Spd Trans.  
 Dodge; B Van; 1996-1994; V-8 5.9 Eng.; Outlet (Driver Side)

## Numerical Listing - Oil Cooler Assemblies & End Fittings

### B61127

Jeep; Grand Cherokee; 1997; 6-Cyl. 4.0 Eng.; Aux. Cooler Inlet Tube From Rad (Upper)  
Jeep; Grand Cherokee; 1997-1993; V-8 5.2 Eng.; Aux. Cooler Inlet Tube From Rad (Upper)

### B61129

Dodge; D & W Pickup; 1993-1989; 6-Cyl. 5.9 Diesel Eng.; Oil Cooler Inlet Tube To Trans. (Front); W/Sensor

### B61132

Dodge; Dakota; 1996-1994; V-8 5.2 Eng.; Outlet (Driver Side)

### B61133

Dodge; Dakota; 1996-1994; V-6 3.9 Eng.; Outlet (Driver Side)

### B61135

Dodge; Dakota; 1996-1994; V-8 5.2 Eng.; Inlet Tube To Trans. (Pass. Side); W/O Snow Plow Pkg

### B61137

Buick; Riviera; 1993-1991; V-6 3.8 Eng.; Inlet From Rad (Upper)  
Cad; Deville; 1995-1994; V-8 4.9 Eng.; Inlet From Rad (Upper)  
Cad; Eldorado; 1993-1991; V-8 4.9 Eng.; Inlet From Rad (Upper)  
Cad; Seville; 1993-1991; V-8 4.9 Eng.; Inlet From Rad (Upper)  
Olds; Toronado; 1992-1991; V-6 3.8 Eng.; Inlet From Rad (Upper)

### B61138

Dodge; Dakota; 1996-1994; V-6 3.9 Eng.; Inlet Tube To Trans. (Pass. Side); W/O Snow Plow Pkg

### B61141

Dodge; Ram Pickup; 1996-1994; 6-Cyl. 5.9 Diesel Eng.; Oil Cooler Inlet Tube To Trans. (Front)  
Dodge; Ram Pickup; 1994; V-8 5.9 Eng.; Oil Cooler Inlet Tube To Trans. (Front)

### B61143

Buick; Reatta; 1991; V-6 3.8 Eng.; Inlet (Lower)  
Buick; Riviera; 1993-1991; V-6 3.8 Eng.; Outlet From Rad (Lower)  
Cad; Deville; 1995-1994; V-8 4.9 Eng.; Outlet From Rad (Lower)  
Cad; Eldorado; 1993; V-8 4.6 Eng.; Outlet From Rad (Lower)  
Cad; Eldorado; 1993-1991; V-8 4.9 Eng.; Outlet From Rad (Lower)  
Cad; Seville; 1993-1991; V-8 4.9 Eng.; Outlet From Rad (Lower)  
Olds; Toronado; 1992-1991; V-6 3.8 Eng.; Outlet From Rad (Lower)

### B61144

Jeep; Grand Cherokee; 1995-1993; V-8 5.2 Eng.; Inlet Tube (Lower) To Trans. (Front)

### B61146

Jeep; Cherokee; 2001-1997; 6-Cyl. 4.0 Eng.; Aux. Cooler Outlet (Upper) To Trans. (Rear)

### B61147

Jeep; Cherokee; 2001-1997; 6-Cyl. 4.0 Eng.; Inlet From Rad Tube (Upper) To Trans. (Front)

### B61148

Dodge; B Van; 2003-2000; V-6 3.9 Eng.; Inlet Tube To Trans. (Pass. Side); W/4-Spd Trans.  
Dodge; B Van; 2003-2000; V-8 5.2 Eng.; Inlet Tube To Trans. (Pass. Side); W/4-Spd Trans.  
Dodge; B Van; 1999-1998; V-8 5.2 Eng.; Inlet Tube To Trans. (Pass. Side)  
Dodge; B Van; 2003-2000; V-8 5.9 Eng.; Inlet Tube To Trans. (Pass. Side); W/4-Spd Trans.  
Dodge; B Van; 1999-1998; V-8 5.9 Eng.; Inlet Tube To Trans. (Pass. Side)

### B61151

Dodge; Dakota; 1999-1997; V-6 3.9 Eng.; Inlet Tube To Trans. (Pass. Side); W/4WD

### B61151 - Continued

Dodge; Dakota; 1999-1997; V-8 5.2 Eng.; Inlet Tube To Trans. (Pass. Side); W/4WD

### B61153

Dodge; Dakota; 2000; V-6 3.9 Eng.; Outlet (Driver Side)  
Dodge; Dakota; 1999-1997; V-6 3.9 Eng.; Outlet (Driver Side); W/2WD  
Dodge; Dakota; 1999-1997; V-8 5.2 Eng.; Outlet (Driver Side); W/2WD  
Dodge; Durango; 1999; V-6 3.9 Eng.; Outlet (Driver Side); W/2WD  
Dodge; Durango; 1999; V-8 5.2 Eng.; Outlet From Rad (Driver Side); W/2WD

### B61154

Dodge; Dakota; 1999-1997; V-6 3.9 Eng.; Outlet (Driver Side); W/4WD  
Dodge; Dakota; 1999-1997; V-8 5.2 Eng.; Outlet (Driver Side); W/4WD

### B61155

Dodge; Ram Pickup; 1999-1996; V-8 5.2 Eng.; Inlet Tube To Trans. (Upper)  
Dodge; Ram Pickup; 1995-1994; V-8 5.2 Eng.; Inlet Tube To Trans. (Upper); W/O Sensor Port  
Dodge; Ram Pickup; 1999-1996; V-8 5.9 Eng.; Inlet Tube To Trans. (Upper)  
Dodge; Ram Pickup; 1995-1994; V-8 5.9 Eng.; Inlet Tube To Trans. (Upper); W/O Sensor Port

### B61157

Dodge; Ram Pickup; 2002-1996; V-10 8.0 Eng.; Inlet Tube To Trans. (Upper)

### B61159

Chev; C&K Pickup; 1995-1993; V-8 7.4 Eng.; Aux. Cooler Outlet (Pass. Side); Exc 3500HD  
Chev; Suburban; 1995-1993; V-8 7.4 Eng.; Aux. Cooler Outlet (Driver Side)  
GMC; C&K Pickup; 1995-1993; V-8 7.4 Eng.; Aux. Cooler Outlet (Pass. Side); Exc 3500HD  
GMC; Suburban; 1995-1993; V-8 7.4 Eng.; Aux. Cooler Outlet (Driver Side)

### B61160

Dodge; Ram Pickup; 2001-1997; V-6 3.9 Eng.; Inlet Tube To Trans. (Upper)  
Dodge; Ram Pickup; 1996-1994; V-6 3.9 Eng.; Inlet Tube To Trans. (Upper); W/42RH Trans.

### B61161

Dodge; Dakota; 1999-1998; V-8 5.9 Eng.; Inlet Tube To Trans. (Pass. Side); W/2WD  
Dodge; Durango; 1999; V-8 5.9 Eng.; Inlet Tube To Trans. (Pass. Side); W/2WD

### B61163

Dodge; Dakota; 1999-1998; V-8 5.9 Eng.; Inlet Tube To Trans. (Pass. Side); W/4WD

### B61164

Dodge; Dakota; 2003-2000; V-8 5.9 Eng.; Outlet From Rad (Driver Side)  
Dodge; Dakota; 1999-1998; V-8 5.9 Eng.; Outlet From Rad (Driver Side); W/2WD  
Dodge; Durango; 2003-2000; V-8 5.9 Eng.; Outlet From Rad (Driver Side)  
Dodge; Durango; 1999; V-8 5.9 Eng.; Outlet From Rad (Driver Side); W/2WD

### B61165

Chev; Blazer Full Size; 1994; V-8 6.5 Diesel Eng.; Aux. Cooler Outlet (Driver Side)  
Chev; C&K Pickup; 1995-1993; V-8 6.5 Diesel Eng.; Aux. Cooler Outlet (Driver Side); W/17-Bolt Trans. Pan (MT1)  
Chev; Suburban; 1995-1994; V-8 6.5 Diesel Eng.; Aux. Cooler Outlet (Driver Side)  
Chev; Tahoe; 1995; V-8 6.5 Diesel Eng.; Aux. Cooler Outlet (Driver Side)  
GMC; C&K Pickup; 1995-1993; V-8 6.5 Diesel Eng.; Aux. Cooler Outlet (Driver Side); W/17-Bolt Trans. Pan (MT1)  
GMC; Suburban; 1995-1994; V-8 6.5 Diesel Eng.; Aux. Cooler Outlet (Driver Side)

# Numerical Listing - Oil Cooler Assemblies & End Fittings

## B61166

Dodge; Durango; 1999; V-6 3.9 Eng.; Inlet Tube To Trans. (Pass. Side); W/4WD  
 Dodge; Durango; 1998; V-6 3.9 Eng.; Inlet Tube To Trans. (Pass. Side)  
 Dodge; Durango; 1999; V-8 5.2 Eng.; Inlet Tube To Trans. (Pass. Side); W/4WD  
 Dodge; Durango; 1998; V-8 5.2 Eng.; Inlet Tube To Trans. (Pass. Side)  
 Dodge; Durango; 1999; V-8 5.9 Eng.; Inlet Tube To Trans. (Pass. Side); W/4WD  
 Dodge; Durango; 1998; V-8 5.9 Eng.; Inlet Tube To Trans. (Pass. Side)

## B61167

Dodge; Durango; 1999; V-6 3.9 Eng.; Outlet (Driver Side); W/4WD  
 Dodge; Durango; 1998; V-6 3.9 Eng.; Outlet (Driver Side)  
 Dodge; Durango; 1999; V-8 5.2 Eng.; Outlet From Rad (Driver Side); W/4WD  
 Dodge; Durango; 1998; V-8 5.2 Eng.; Outlet (Driver Side)  
 Dodge; Durango; 1999; V-8 5.9 Eng.; Outlet From Rad (Driver Side); W/4WD  
 Dodge; Durango; 1998; V-8 5.9 Eng.; Outlet (Driver Side)

## B61168

Dodge; Ram Pickup; 2001-1994; V-6 3.9 Eng.; Outlet (Lower)

## B61169

Chev; C&K Pickup; 1995-1993; V-8 7.4 Eng.; Aux. Cooler Inlet (Pass. Side); Exc 3500HD  
 Chev; Suburban; 1995-1993; V-8 7.4 Eng.; Aux. Cooler Inlet (Pass. Side)  
 GMC; C&K Pickup; 1995-1993; V-8 7.4 Eng.; Aux. Cooler Inlet (Pass. Side); Exc 3500HD  
 GMC; Suburban; 1995-1993; V-8 7.4 Eng.; Aux. Cooler Inlet (Pass. Side)

## B61170

Dodge; B Van; 1997-1994; V-8 5.2 Eng.; Inlet Tube To Trans. (Pass. Side)  
 Dodge; B Van; 1997-1994; V-8 5.9 Eng.; Inlet Tube To Trans. (Pass. Side)

## B61173

Jeep; Grand Cherokee; 1997-1996; 6-Cyl. 4.0 Eng.; Inlet Tube From Rad (Upper) To Trans. (Front)

## B61175

Jeep; Grand Cherokee; 1997-1996; 6-Cyl. 4.0 Eng.; Outlet From Rad (Lower) To Trans. (Rear)

## B61176

Ford; Thunderbird; 1995-1990; V-6 3.8 Eng.; Outlet (Lower); W/O Schgr  
 Ford; Thunderbird; 1993-1991; V-8 5.0 Eng.; Outlet (Lower)  
 Merc; Cougar; 1995-1991; V-6 3.8 Eng.; Outlet (Lower)  
 Merc; Cougar; 1990; V-6 3.8 Eng.; Outlet (Lower); W/O Schgr  
 Merc; Cougar; 1993-1991; V-8 5.0 Eng.; Outlet (Lower)

## B61177

Ford; Taurus; 1992-1990; V-6 3.8 Eng.; Inlet (Upper)  
 Linc; Continental; 1994-1990; V-6 3.8 Eng.; Inlet To Trans. (Lower)  
 Merc; Sable; 1992-1990; V-6 3.8 Eng.; Inlet (Upper)

## B61178

Ford; Taurus; 1995-1993; V-6 3.0 Eng.; Aux. Cooler Supply Tube (Lower)  
 Ford; Taurus; 1995-1990; V-6 3.8 Eng.; Aux. Cooler Supply Tube (Lower); W/Police Pkg  
 Merc; Sable; 1995-1993; V-6 3.0 Eng.; Aux. Cooler Supply Tube (Lower)  
 Merc; Sable; 1995-1990; V-6 3.8 Eng.; Aux. Cooler Supply Tube (Lower); W/Police Pkg

## B61179

Ford; Crown Victoria; 1997-1996; V-8 4.6 Eng.; Aux. Cooler Outlet (Lower)  
 Merc; Grand Marquis; 1997-1996; V-8 4.6 Eng.; Aux. Cooler Outlet (Lower)

## B61180

Ford; Crown Victoria; 1997-1996; V-8 4.6 Eng.; Aux. Cooler Inlet From Rad (Upper)

## B61180 - Continued

Merc; Grand Marquis; 1997-1996; V-8 4.6 Eng.; Aux. Cooler Inlet From Rad (Upper)

## B61181

Linc; Town Car; 1999-1995; V-8 4.6 Eng.; Aux. Cooler To Tube (Lower)

## B61182

Linc; Town Car; 1999-1995; V-8 4.6 Eng.; Aux. Cooler To Rad (Upper)

## B61183

Ford; Explorer; 1997-1996; V-8 5.0 Eng.; Inlet From Rad (Lower)  
 Merc; Mountaineer; 1997; V-8 5.0 Eng.; Inlet From Rad (Lower)

## B61184

Ford; Explorer; 1997-1996; V-8 5.0 Eng.; Outlet From Rad (Upper)  
 Merc; Mountaineer; 1997; V-8 5.0 Eng.; Outlet From Rad (Upper)

## B61185

Ford; Crown Victoria; 1997-1996; V-8 4.6 Eng.; Inlet To Trans. (Lower); W/Aux. Cooler  
 Linc; Town Car; 1997-1996; V-8 4.6 Eng.; Inlet To Trans. (Lower)  
 Merc; Grand Marquis; 1997-1996; V-8 4.6 Eng.; Inlet To Trans. (Lower); W/Aux. Cooler

## B61186

Ford; Expedition; 2000-1997; V-8 5.4 Eng.; Inlet From Rad (Lower); W/O Aux. Cooler  
 Ford; F Pickup; 2000-1998; V-8 5.4 Eng.; Inlet From Rad (Lower); W/4R100 Trans.; W/O Aux. Cooler  
 Ford; F Pickup; 1997; V-8 5.4 Eng.; Inlet From Rad (Lower); W/E4OD Trans.; W/O Aux. Cooler  
 Ford; F Pickup; 1997; V-8 5.8 Eng.; Inlet From Rad (Lower)  
 Ford; F Pickup; 1997; V-8 7.3 Diesel Eng.; Inlet From Rad (Lower)  
 Ford; F Pickup; 1997; V-8 7.5 Eng.; Inlet From Rad (Lower)  
 Ford; Super Duty Pickup; 1997; V-8 7.3 Diesel Eng.; Inlet From Rad (Lower)  
 Linc; Navigator; 2002-1998; V-8 5.4 Eng.; Inlet From Rad (Lower); W/O Aux. Cooler

## B61187

Ford; Expedition; 2000-1997; V-8 5.4 Eng.; Inlet To Trans. (Rear); W/Aux. Cooler  
 Ford; F Pickup; 2002-2000; V-8 5.4 Eng.; Inlet To Trans. (Rear); W/4R100 Trans.; W/Aux. Cooler; Under 8500 GVW  
 Ford; F Pickup; 1999-1998; V-8 5.4 Eng.; Inlet To Trans. (Rear); W/4R100 Trans.; W/Aux. Cooler  
 Ford; F Pickup; 1997; V-8 5.4 Eng.; Inlet To Trans. (Rear); W/E4OD Trans.; W/Aux. Cooler  
 Ford; F Pickup; 1997; V-8 5.8 Eng.; Inlet To Trans. (Rear); W/Aux. Cooler  
 Ford; F Pickup; 1997; V-8 7.3 Diesel Eng.; Inlet To Trans. (Rear); W/Aux. Cooler  
 Ford; F Pickup; 1997; V-8 7.5 Eng.; Inlet To Trans. (Rear); W/Aux. Cooler  
 Ford; Super Duty Pickup; 1997; V-8 7.3 Diesel Eng.; Inlet To Trans. (Rear); W/Aux. Cooler  
 Linc; Navigator; 2000-1998; V-8 5.4 Eng.; Inlet To Trans. (Rear); W/Aux. Cooler

## B61188

Ford; Expedition; 1998-1997; V-8 4.6 Eng.; Inlet From Rad (Lower); W/O Aux. Cooler  
 Ford; F Pickup; 1998-1997; V-6 4.2 Eng.; Inlet From Rad (Lower); W/O Aux. Cooler  
 Ford; F Pickup; 1998-1997; V-8 4.6 Eng.; Inlet From Rad (Lower); W/O Aux. Cooler  
 Ford; F Pickup; 1998-1997; V-8 5.4 Eng.; Inlet From Rad (Lower); W/4R70W Trans.; W/O Aux. Cooler

## B61189

Ford; Expedition; 2002-2000; V-8 4.6 Eng.; Inlet To Trans. (Upper); W/Super Cooling; Under 8500 GVW  
 Ford; Expedition; 1999-1997; V-8 4.6 Eng.; Inlet To Trans. (Upper); W/Aux. Cooler  
 Ford; F Pickup; 2002-2001; V-6 4.2 Eng.; Inlet To Trans. (Upper); W/Super Cooling; Under 8500 GVW  
 Ford; F Pickup; 2000; V-6 4.2 Eng.; Inlet To Trans. (Upper); W/Super Cooling

## Numerical Listing - Oil Cooler Assemblies & End Fittings

### B61189 - Continued

Ford; F Pickup; 1999-1997; V-6 4.2 Eng.; Inlet To Trans. (Upper); W/Aux. Cooler  
 Ford; F Pickup; 2002-2001; V-8 4.6 Eng.; Inlet To Trans. (Upper); W/Super Cooling; Under 8500 GVW  
 Ford; F Pickup; 2000; V-8 4.6 Eng.; Inlet To Trans. (Upper); W/Super Cooling  
 Ford; F Pickup; 1999-1997; V-8 4.6 Eng.; Inlet To Trans. (Upper); W/Aux. Cooler  
 Ford; F Pickup; 2002-2000; V-8 5.4 Eng.; Inlet To Trans. (Upper); W/4R70W Trans.; W/Super Cooling  
 Ford; F Pickup; 1999-1997; V-8 5.4 Eng.; Inlet To Trans. (Upper); W/4R70W Trans.; W/Aux. Cooler

### B61190

Ford; Expedition; 1998-1997; V-8 5.4 Eng.; Outlet From Rad (Upper); W/Aux. Cooler  
 Ford; F Pickup; 1998; V-8 5.4 Eng.; Outlet From Rad (Upper); W/4R100 Trans.; W/Aux. Cooler  
 Ford; F Pickup; 1997; V-8 5.4 Eng.; Outlet From Rad (Upper); W/E4OD Trans.; W/Aux. Cooler  
 Ford; F Pickup; 1997; V-8 5.8 Eng.; Outlet From Rad (Upper); W/Aux. Cooler  
 Ford; F Pickup; 1997; V-8 7.3 Diesel Eng.; Outlet From Rad (Upper); W/Aux. Cooler  
 Ford; F Pickup; 1997; V-8 7.5 Eng.; Outlet From Rad (Upper); W/Aux. Cooler  
 Ford; Super Duty Pickup; 1997; V-8 7.3 Diesel Eng.; Outlet From Rad (Upper); W/Aux. Cooler

### B61191

Ford; Expedition; 1998-1997; V-8 4.6 Eng.; Outlet From Rad (Upper)  
 Ford; F Pickup; 1998-1997; V-6 4.2 Eng.; Outlet From Rad (Upper)  
 Ford; F Pickup; 1998-1997; V-8 4.6 Eng.; Outlet From Rad (Upper)  
 Ford; F Pickup; 1998-1997; V-8 5.4 Eng.; Outlet From Rad (Upper); W/4R70W Trans.

### B61192

Ford; Expedition; 2002-2000; V-8 4.6 Eng.; Aux. Cooler Outlet (Driver Side); W/Super Cooling  
 Ford; Expedition; 1999-1997; V-8 4.6 Eng.; Aux. Cooler Outlet (Driver Side)  
 Ford; F Pickup; 2002-2000; V-6 4.2 Eng.; Aux. Cooler Outlet (Driver Side); W/Super Cooling  
 Ford; F Pickup; 1999-1997; V-6 4.2 Eng.; Aux. Cooler Outlet (Driver Side)  
 Ford; F Pickup; 2002-2000; V-8 4.6 Eng.; Aux. Cooler Outlet (Driver Side); W/Super Cooling  
 Ford; F Pickup; 1999-1997; V-8 4.6 Eng.; Aux. Cooler Outlet (Driver Side)  
 Ford; F Pickup; 2002-2000; V-8 5.4 Eng.; Aux. Cooler Outlet (Driver Side); W/4R70W Trans.; W/Super Cooling  
 Ford; F Pickup; 1999-1997; V-8 5.4 Eng.; Aux. Cooler Outlet (Driver Side); W/4R70W Trans.

### B61193

Ford; Expedition; 2000-1997; V-8 5.4 Eng.; Aux. Cooler Outlet (Driver Side)  
 Ford; F Pickup; 1999-1998; V-8 5.4 Eng.; Aux. Cooler Outlet (Driver Side); W/4R100 Trans.  
 Ford; F Pickup; 1997; V-8 5.4 Eng.; Aux. Cooler Outlet (Driver Side); W/E4OD Trans.  
 Ford; F Pickup; 1997; V-8 5.8 Eng.; Aux. Cooler Outlet (Driver Side)  
 Ford; F Pickup; 1997; V-8 7.3 Diesel Eng.; Aux. Cooler Outlet (Driver Side)  
 Ford; F Pickup; 1997; V-8 7.5 Eng.; Aux. Cooler Outlet (Driver Side)  
 Ford; Super Duty Pickup; 1997; V-8 7.3 Diesel Eng.; Aux. Cooler Outlet (Driver Side)  
 Linc; Navigator; 2000-1998; V-8 5.4 Eng.; Aux. Cooler Outlet (Driver Side)

### B61194

Ford; Expedition; 1998; V-8 5.4 Eng.; Outlet From Rad (Upper); W/O Aux. Cooler; 1-14 & Older  
 Ford; Expedition; 1997; V-8 5.4 Eng.; Outlet From Rad (Upper); W/O Aux. Cooler  
 Ford; F Pickup; 1998; V-8 5.4 Eng.; Outlet From Rad (Upper); W/4R100 Trans.; W/O Aux. Cooler; 1-14 & Older  
 Ford; F Pickup; 1997; V-8 5.4 Eng.; Outlet From Rad (Upper); W/E4OD Trans.; W/O Aux. Cooler  
 Ford; F Pickup; 1997; V-8 5.8 Eng.; Outlet From Rad (Upper); W/O Aux. Cooler  
 Ford; F Pickup; 1997; V-8 7.3 Diesel Eng.; Outlet From Rad (Upper); W/O Aux. Cooler

### B61194 - Continued

Ford; F Pickup; 1997; V-8 7.5 Eng.; Outlet From Rad (Upper); W/O Aux. Cooler  
 Ford; Super Duty Pickup; 1997; V-8 7.3 Diesel Eng.; Outlet From Rad (Upper); W/O Aux. Cooler

### B61196

Ford; Expedition; 2002-2000; V-8 4.6 Eng.; Inlet From Rad (Lower); W/O Aux. Cooler; Under 8500 GVW  
 Ford; Expedition; 1999; V-8 4.6 Eng.; Inlet From Rad (Lower); W/O Aux. Cooler  
 Ford; Expedition; 1999; V-8 5.4 Eng.; Inlet To Trans. (Rear); Under 8500 GVW  
 Ford; F Pickup; 2002-2001; V-6 4.2 Eng.; Inlet From Rad (Lower); W/O Aux. Cooler; Under 8500 GVW  
 Ford; F Pickup; 2000-1999; V-6 4.2 Eng.; Inlet From Rad (Lower); W/O Aux. Cooler  
 Ford; F Pickup; 2002-2001; V-8 4.6 Eng.; Inlet From Rad (Lower); W/O Aux. Cooler; Under 8500 GVW  
 Ford; F Pickup; 2000-1999; V-8 4.6 Eng.; Inlet From Rad (Lower); W/O Aux. Cooler  
 Ford; F Pickup; 2002-1999; V-8 5.4 Eng.; Inlet From Rad (Lower); W/4R70W Trans.; W/O Aux. Cooler  
 Ford; F Pickup; 1999; V-8 5.4 Eng.; Inlet From Rad (Lower); W/4R100 Trans.; Under 8500 GVW

### B61197

Ford; Expedition; 2002-2000; V-8 4.6 Eng.; Outlet From Rad (Upper); W/Super Cooling  
 Ford; Expedition; 1999; V-8 4.6 Eng.; Outlet From Rad (Upper)  
 Ford; F Pickup; 2002-2000; V-6 4.2 Eng.; Outlet From Rad (Upper); W/Super Cooling  
 Ford; F Pickup; 1999; V-6 4.2 Eng.; Outlet From Rad (Upper)  
 Ford; F Pickup; 2002-2000; V-8 4.6 Eng.; Outlet From Rad (Upper); W/Super Cooling  
 Ford; F Pickup; 1999; V-8 4.6 Eng.; Outlet From Rad (Upper)  
 Ford; F Pickup; 2002-2000; V-8 5.4 Eng.; Outlet From Rad (Upper); W/4R70W Trans.; W/Super Cooling  
 Ford; F Pickup; 1999; V-8 5.4 Eng.; Outlet From Rad (Upper); W/4R70W Trans.

### B61198

Ford; Expedition; 2002; V-8 5.4 Eng.; Outlet From Rad (Upper)  
 Ford; Expedition; 2000; V-8 5.4 Eng.; Outlet From Rad (Upper); W/Aux. Cooler  
 Ford; Expedition; 1999; V-8 5.4 Eng.; Outlet From Rad (Upper)  
 Ford; Expedition; 1998; V-8 5.4 Eng.; Outlet From Rad (Upper); W/O Aux. Cooler; 1-15 & Newer  
 Ford; F Pickup; 2002-1999; V-8 5.4 Eng.; Outlet From Rad (Upper); W/4R100 Trans.  
 Ford; F Pickup; 1998; V-8 5.4 Eng.; Outlet From Rad (Upper); W/4R100 Trans.; W/O Aux. Cooler; 1-15 & Newer  
 Linc; Navigator; 2000-1998; V-8 5.4 Eng.; Outlet From Rad (Upper); W/Aux. Cooler

### B61199

Dodge; B Van; 2003-2000; V-6 3.9 Eng.; Inlet Tube To Trans. (Pass. Side); W/3-Spd Trans.  
 Dodge; B Van; 1999-1998; V-6 3.9 Eng.; Inlet Tube To Trans. (Pass. Side)  
 Dodge; B Van; 2003-2000; V-8 5.2 Eng.; Inlet Tube To Trans. (Pass. Side); W/3-Spd Trans.  
 Dodge; B Van; 2003-2000; V-8 5.9 Eng.; Inlet Tube To Trans. (Pass. Side); W/3-Spd Trans.

### B61200

Dodge; Dakota; 2002-2000; V-6 3.9 Eng.; Inlet Tube To Trans. (Pass. Side)  
 Dodge; Dakota; 1999-1997; V-6 3.9 Eng.; Inlet Tube To Trans. (Pass. Side); W/2WD  
 Dodge; Dakota; 1999-1997; V-8 5.2 Eng.; Inlet Tube To Trans. (Pass. Side); W/2WD  
 Dodge; Durango; 1999; V-6 3.9 Eng.; Inlet Tube To Trans. (Pass. Side); W/2WD  
 Dodge; Durango; 2000; V-8 5.2 Eng.; Inlet Tube To Trans. (Pass. Side)  
 Dodge; Durango; 1999; V-8 5.2 Eng.; Inlet Tube To Trans. (Pass. Side); W/2WD

# Numerical Listing - Oil Cooler Assemblies & End Fittings

## B61201

Dodge; B Van; 1997-1994; V-6 3.9 Eng.; Inlet Tube To Trans. (Pass. Side)

## B61202

Dodge; Dakota; 2000; V-8 5.9 Eng.; Inlet Tube To Trans. (Pass. Side)  
Dodge; Durango; 2000; V-8 5.9 Eng.; Inlet Tube To Trans. (Pass. Side)

## B61203

Dodge; Dakota; 2003-2001; V-8 5.9 Eng.; Inlet Tube To Trans. (Front)  
Dodge; Durango; 2003-2001; V-8 5.9 Eng.; Inlet Tube To Trans. (Front)

## B61204

Dodge; Ram Pickup; 2001-2000; V-8 5.2 Eng.; Inlet Tube To Trans. (Upper)  
Dodge; Ram Pickup; 2002-2000; V-8 5.9 Eng.; Inlet Tube To Trans. (Upper)

## B61205

Dodge; Dakota; 1999-1998; V-8 5.9 Eng.; Outlet From Rad (Driver Side); W/4WD

## B61207

Jeep; Grand Cherokee; 1997-1996; V-8 5.2 Eng.; Inlet Tube From Rad (Lower) To Trans. (Front)

## B61208

Jeep; Cherokee; 1996-1988; 6-Cyl. 4.0 Eng.; Inlet From Rad Tube (Upper) To Trans. (Front)  
Jeep; Comanche; 1992-1988; 6-Cyl. 4.0 Eng.; Inlet From Rad Tube (Upper) To Trans. (Front)  
Jeep; Wagoneer; 1990-1988; 6-Cyl. 4.0 Eng.; Inlet From Rad Tube (Upper) To Trans. (Front)

## B61209

Dodge; B Van; 1997; V-6 3.9 Eng.; Outlet (Driver Side)  
Dodge; B Van; 1996-1994; V-6 3.9 Eng.; Outlet (Driver Side); W/3-Spd Trans.

## B61210

Jeep; Grand Cherokee; 1997-1996; V-8 5.2 Eng.; Outlet From Rad (Upper) To Trans. (Rear)

## B61211

Chev; Blazer Full Size; 1994-1993; V-8 5.7 Eng.; Aux. Cooler Outlet (Driver Side); W/16-Bolt Trans. Pan (M30)  
Chev; C&K Pickup; 1995-1993; V-8 5.7 Eng.; Aux. Cooler Outlet (Driver Side); Exc 3500HD; W/16-Bolt Trans. Pan (M30)  
Chev; Suburban; 1995-1993; V-8 5.7 Eng.; Aux. Cooler Outlet (Driver Side); W/16-Bolt Trans. Pan (M30)  
Chev; Tahoe; 1995; V-8 5.7 Eng.; Aux. Cooler Outlet (Driver Side)  
GMC; C&K Pickup; 1995-1993; V-8 5.7 Eng.; Aux. Cooler Outlet (Driver Side); Exc 3500HD; W/16-Bolt Trans. Pan (M30)  
GMC; Suburban; 1995-1993; V-8 5.7 Eng.; Aux. Cooler Outlet (Driver Side); W/16-Bolt Trans. Pan (M30)  
GMC; Yukon; 1995-1993; V-8 5.7 Eng.; Aux. Cooler Outlet (Driver Side); W/16-Bolt Trans. Pan (M30)

## B61212

Chev; C&K Pickup; 1995-1993; V-8 6.5 Diesel Eng.; Aux. Cooler Outlet (Driver Side); W/16-Bolt Trans. Pan (M30)  
GMC; C&K Pickup; 1995-1993; V-8 6.5 Diesel Eng.; Aux. Cooler Outlet (Driver Side); W/16-Bolt Trans. Pan (M30)

## B61214

Chev; G Van; 1996-1994; V-8 7.4 Eng.; Outlet (Lower); W/Aux. Cooler  
GMC; G Van; 1996-1994; V-8 7.4 Eng.; Outlet (Lower); W/Aux. Cooler

## B61215

Chev; G Van; 1995-1994; V-6 4.3 Eng.; Aux. Cooler Inlet Hose From Rad (Lower); W/16-Bolt Trans. Pan (M30)  
Chev; G Van; 1995-1994; V-8 5.0 Eng.; Aux. Cooler Inlet Hose From Rad (Lower); W/16-Bolt Trans. Pan (M30)

## B61215 - Continued

Chev; G Van; 1995-1994; V-8 5.7 Eng.; Aux. Cooler Inlet Hose From Rad (Lower); W/16-Bolt Trans. Pan (M30)  
Chev; G Van; 1995-1994; V-8 6.5 Diesel Eng.; Aux. Cooler Inlet Hose From Rad (Lower); W/16-Bolt Trans. Pan (M30)  
GMC; G Van; 1995-1994; V-6 4.3 Eng.; Aux. Cooler Inlet Hose From Rad (Lower); W/16-Bolt Trans. Pan (M30)  
GMC; G Van; 1995-1994; V-8 5.0 Eng.; Aux. Cooler Inlet Hose From Rad (Lower); W/16-Bolt Trans. Pan (M30)  
GMC; G Van; 1995-1994; V-8 5.7 Eng.; Aux. Cooler Inlet Hose From Rad (Lower); W/16-Bolt Trans. Pan (M30)  
GMC; G Van; 1995-1994; V-8 6.5 Diesel Eng.; Aux. Cooler Inlet Hose From Rad (Lower); W/16-Bolt Trans. Pan (M30)

## B61216

Chev; G Van; 1995-1994; V-6 4.3 Eng.; Outlet (Lower); W/Aux. Cooler; W/16-Bolt Trans. Pan (M30)  
Chev; G Van; 1995-1994; V-8 5.0 Eng.; Outlet (Lower); W/Aux. Cooler; W/16-Bolt Trans. Pan (M30)  
Chev; G Van; 1995-1994; V-8 5.7 Eng.; Outlet (Lower); W/Aux. Cooler; W/16-Bolt Trans. Pan (M30)  
Chev; G Van; 1995-1994; V-8 6.5 Diesel Eng.; Outlet (Lower); W/Aux. Cooler; W/16-Bolt Trans. Pan (M30)  
GMC; G Van; 1995-1994; V-6 4.3 Eng.; Outlet (Lower); W/Aux. Cooler; W/16-Bolt Trans. Pan (M30)  
GMC; G Van; 1995-1994; V-8 5.0 Eng.; Outlet (Lower); W/Aux. Cooler; W/16-Bolt Trans. Pan (M30)  
GMC; G Van; 1995-1994; V-8 5.7 Eng.; Outlet (Lower); W/Aux. Cooler; W/16-Bolt Trans. Pan (M30)  
GMC; G Van; 1995-1994; V-8 6.5 Diesel Eng.; Outlet (Lower); W/Aux. Cooler; W/16-Bolt Trans. Pan (M30)

## B61218

Chev; C&K Pickup; 1995-1993; V-8 6.5 Diesel Eng.; Aux. Cooler Inlet (Pass. Side); W/16-Bolt Trans. Pan (M30)  
GMC; C&K Pickup; 1995-1993; V-8 6.5 Diesel Eng.; Aux. Cooler Inlet (Pass. Side); W/16-Bolt Trans. Pan (M30)

## B61232

Buick; Skylark; 1995-1994; 4-Cyl. 2.3 Eng.; Inlet (Upper); W/3-Spd Trans.  
Chev; Beretta; 1996-1994; 4-Cyl. 2.2 Eng.; Inlet (Upper); W/3-Spd Trans.  
Chev; Beretta; 1994; 4-Cyl. 2.3 Eng.; Inlet (Upper); W/3-Spd Trans.  
Chev; Corsica; 1996-1994; 4-Cyl. 2.2 Eng.; Inlet (Upper)  
Olds; Achieva; 1995-1994; 4-Cyl. 2.3 Eng.; Inlet (Upper); W/3-Spd Trans.  
Pont; Grand Am; 1995-1994; 4-Cyl. 2.3 Eng.; Inlet (Upper); W/3-Spd Trans.

## B61233

Buick; Skylark; 1995-1994; 4-Cyl. 2.3 Eng.; Outlet (Lower); W/3-Spd Trans.  
Chev; Beretta; 1996-1994; 4-Cyl. 2.2 Eng.; Outlet (Lower); W/3-Spd Trans.  
Chev; Beretta; 1994; 4-Cyl. 2.3 Eng.; Outlet (Lower); W/3-Spd Trans.  
Chev; Corsica; 1996-1994; 4-Cyl. 2.2 Eng.; Outlet (Lower)  
Olds; Achieva; 1995-1994; 4-Cyl. 2.3 Eng.; Outlet (Lower); W/3-Spd Trans.  
Pont; Grand Am; 1995-1994; 4-Cyl. 2.3 Eng.; Outlet (Lower); W/3-Spd Trans.

## B61234

Ford; Thunderbird; 1995-1990; V-6 3.8 Eng.; Inlet (Upper); W/O Schgr  
Ford; Thunderbird; 1993-1991; V-8 5.0 Eng.; Inlet (Upper)  
Merc; Cougar; 1995-1991; V-6 3.8 Eng.; Inlet (Upper)  
Merc; Cougar; 1990; V-6 3.8 Eng.; Inlet (Upper); W/O Schgr  
Merc; Cougar; 1993-1991; V-8 5.0 Eng.; Inlet (Upper)

## B61235

Chev; Blazer Full Size; 1994-1993; V-8 5.7 Eng.; Aux. Cooler Outlet (Driver Side); W/17-Bolt Trans. Pan (MT1)  
Chev; C&K Pickup; 1995-1993; V-8 5.7 Eng.; Aux. Cooler Outlet (Driver Side); Exc 3500HD; W/17-Bolt Trans. Pan (MT1)  
Chev; Suburban; 1995-1993; V-8 5.7 Eng.; Aux. Cooler Outlet (Driver Side); W/17-Bolt Trans. Pan (MT1)  
GMC; C&K Pickup; 1995-1993; V-8 5.7 Eng.; Aux. Cooler Outlet (Driver Side); Exc 3500HD; W/17-Bolt Trans. Pan (MT1)  
GMC; Suburban; 1995-1993; V-8 5.7 Eng.; Aux. Cooler Outlet (Driver Side); W/17-Bolt Trans. Pan (MT1)  
GMC; Yukon; 1995-1993; V-8 5.7 Eng.; Aux. Cooler Outlet (Driver Side); W/17-Bolt Trans. Pan (MT1)

# Numerical Listing - Oil Cooler Assemblies & End Fittings

## B61237

Chev; Lumina; 1999-1995; V-6 3.1 Eng.; Aux. Cooler Inlet (Upper)  
 Chev; Lumina; 1997-1995; V-6 3.4 Eng.; Aux. Cooler Inlet (Upper)  
 Chev; Lumina; 1999-1998; V-6 3.8 Eng.; Aux. Cooler Inlet (Upper)  
 Chev; Monte Carlo; 1999-1995; V-6 3.1 Eng.; Aux. Cooler Inlet (Upper)  
 Chev; Monte Carlo; 1997-1995; V-6 3.4 Eng.; Aux. Cooler Inlet (Upper)  
 Chev; Monte Carlo; 1999-1998; V-6 3.8 Eng.; Aux. Cooler Inlet (Upper)  
 Olds; Intrigue; 1998; V-6 3.8 Eng.; Aux. Cooler Inlet (Upper)  
 Pont; Grand Prix; 1999-1998; V-6 3.1 Eng.; Aux. Cooler Inlet (Upper)  
 Pont; Grand Prix; 1999-1998; V-6 3.8 Eng.; Aux. Cooler Inlet (Upper)

## B61238

Buick; Century; 1999-1998; V-6 3.1 Eng.; Outlet (Lower)  
 Buick; Regal; 1999-1998; V-6 3.8 Eng.; Outlet (Lower)  
 Chev; Lumina; 1999-1998; V-6 3.1 Eng.; Outlet (Lower); W/O Aux. Cooler  
 Chev; Lumina; 1999-1998; V-6 3.8 Eng.; Outlet (Lower); W/O Aux. Cooler  
 Chev; Monte Carlo; 1999-1998; V-6 3.1 Eng.; Outlet (Lower); W/O Aux. Cooler  
 Chev; Monte Carlo; 1999-1998; V-6 3.8 Eng.; Outlet (Lower); W/O Aux. Cooler  
 Olds; Intrigue; 1999; V-6 3.8 Eng.; Outlet (Lower)  
 Olds; Intrigue; 1998; V-6 3.8 Eng.; Outlet (Lower); W/O Aux. Cooler  
 Pont; Grand Prix; 1999-1998; V-6 3.1 Eng.; Outlet (Lower); W/O Aux. Cooler  
 Pont; Grand Prix; 1999-1998; V-6 3.8 Eng.; Outlet (Lower); W/O Aux. Cooler

## B61239

Buick; Century; 1999-1998; V-6 3.1 Eng.; Inlet (Upper)  
 Buick; Regal; 1999-1998; V-6 3.8 Eng.; Inlet (Upper)  
 Chev; Lumina; 1999-1998; V-6 3.1 Eng.; Inlet (Upper); W/O Aux. Cooler  
 Chev; Lumina; 1999-1998; V-6 3.8 Eng.; Inlet (Upper); W/O Aux. Cooler  
 Chev; Monte Carlo; 1999-1998; V-6 3.1 Eng.; Inlet (Upper); W/O Aux. Cooler  
 Chev; Monte Carlo; 1999-1998; V-6 3.8 Eng.; Inlet (Upper); W/O Aux. Cooler  
 Olds; Intrigue; 1999; V-6 3.8 Eng.; Inlet (Upper)  
 Olds; Intrigue; 1998; V-6 3.8 Eng.; Inlet (Upper); W/O Aux. Cooler  
 Pont; Grand Prix; 1999-1998; V-6 3.1 Eng.; Inlet (Upper); W/O Aux. Cooler  
 Pont; Grand Prix; 1999-1998; V-6 3.8 Eng.; Inlet (Upper); W/O Aux. Cooler

## B61240

Chev; C&K Pickup; 1997-1996; V-8 5.7 Eng.; Aux. Cooler Inlet (Pass. Side); Exc 3500HD; W/16-Bolt Trans. Pan (M30)  
 Chev; Suburban; 1997-1996; V-8 5.7 Eng.; Aux. Cooler Inlet (Pass. Side); W/16-Bolt Trans. Pan (M30)  
 Chev; Tahoe; 1997; V-8 5.7 Eng.; Aux. Cooler Inlet (Pass. Side)  
 Chev; Tahoe; 1996; V-8 5.7 Eng.; Aux. Cooler Inlet (Pass. Side); W/16-Bolt Trans. Pan (M30)  
 GMC; C&K Pickup; 1997-1996; V-8 5.7 Eng.; Aux. Cooler Inlet (Pass. Side); Exc 3500HD; W/16-Bolt Trans. Pan (M30)  
 GMC; Suburban; 1997-1996; V-8 5.7 Eng.; Aux. Cooler Inlet (Pass. Side); W/16-Bolt Trans. Pan (M30)  
 GMC; Yukon; 1997-1996; V-8 5.7 Eng.; Aux. Cooler Inlet (Pass. Side); W/16-Bolt Trans. Pan (M30)

## B61241

Buick; Lesabre; 1997; V-6 3.8 Eng.; Inlet From Rad (Upper); 2-18 & Older  
 Buick; Lesabre; 1996; V-6 3.8 Eng.; Inlet From Rad (Upper)  
 Buick; Park Ave.; 1996; V-6 3.8 Eng.; Inlet From Rad (Upper); W/O Aux. Cooler  
 Olds; Eighty Eight; 1997; V-6 3.8 Eng.; Inlet From Rad (Upper); 2-18 & Older  
 Olds; Eighty Eight; 1996; V-6 3.8 Eng.; Inlet (Upper); W/O Aux. Cooler  
 Olds; Ninety Eight; 1996; V-6 3.8 Eng.; Inlet (Upper)  
 Olds; Regency; 1997; V-6 3.8 Eng.; Inlet From Rad (Upper); 2-18 & Older  
 Pont; Bonneville; 1997; V-6 3.8 Eng.; Inlet From Rad (Upper); 2-18 & Older  
 Pont; Bonneville; 1996; V-6 3.8 Eng.; Inlet (Upper); W/O Aux. Cooler

## B61242

Buick; Lesabre; 1992-1991; V-6 3.8 Eng.; Inlet From Rad (Upper); W/O Aux. Cooler  
 Buick; Park Ave.; 1993-1991; V-6 3.8 Eng.; Inlet From Rad (Upper); W/O Aux. Cooler  
 Cad; Deville; 1993-1991; V-8 4.9 Eng.; Inlet From Rad (Upper); W/O Aux. Cooler

## B61242 - Continued

Cad; Fleetwood; 1992-1991; V-8 4.9 Eng.; Inlet From Rad (Upper); W/O Aux. Cooler  
 Cad; Sixty Special; 1993; V-8 4.9 Eng.; Inlet From Rad (Upper); W/O Aux. Cooler  
 Olds; Eighty Eight; 1992-1991; V-6 3.8 Eng.; Inlet From Rad (Upper); W/O Aux. Cooler  
 Olds; Ninety Eight; 1992-1991; V-6 3.8 Eng.; Inlet From Rad (Upper); W/O Aux. Cooler  
 Pont; Bonneville; 1992-1991; V-6 3.8 Eng.; Inlet From Rad (Upper); W/O Aux. Cooler

## B61244

Buick; Lesabre; 1993-1991; V-6 3.8 Eng.; Outlet From Rad (Lower)  
 Buick; Park Ave.; 1993-1991; V-6 3.8 Eng.; Outlet From Rad (Lower)  
 Cad; Deville; 1993-1991; V-8 4.9 Eng.; Outlet From Rad (Lower)  
 Cad; Fleetwood; 1992-1991; V-8 4.9 Eng.; Outlet From Rad (Lower)  
 Cad; Sixty Special; 1993; V-8 4.9 Eng.; Outlet From Rad (Lower)  
 Olds; Eighty Eight; 1993-1991; V-6 3.8 Eng.; Outlet From Rad (Lower)  
 Olds; Ninety Eight; 1992-1991; V-6 3.8 Eng.; Outlet From Rad (Lower)  
 Pont; Bonneville; 1993-1991; V-6 3.8 Eng.; Outlet From Rad (Lower)

## B61245

Buick; Lesabre; 1992-1991; V-6 3.8 Eng.; Inlet From Rad (Upper); W/Aux. Cooler  
 Buick; Park Ave.; 1993-1991; V-6 3.8 Eng.; Inlet From Rad (Upper); W/Aux. Cooler  
 Cad; Deville; 1993-1991; V-8 4.9 Eng.; Inlet From Rad (Upper); W/Aux. Cooler  
 Cad; Fleetwood; 1992-1991; V-8 4.9 Eng.; Inlet From Rad (Upper); W/Aux. Cooler  
 Cad; Sixty Special; 1993; V-8 4.9 Eng.; Inlet From Rad (Upper); W/Aux. Cooler  
 Olds; Eighty Eight; 1992-1991; V-6 3.8 Eng.; Inlet To Trans. (Lower); W/Aux. Cooler  
 Olds; Ninety Eight; 1992-1991; V-6 3.8 Eng.; Inlet To Trans. (Lower); W/Aux. Cooler  
 Pont; Bonneville; 1992-1991; V-6 3.8 Eng.; Inlet To Trans. (Lower); W/Aux. Cooler

## B61250

Chev; Astro; 2005-1996; V-6 4.3 Eng.; Outlet (Lower)  
 GMC; Safari; 2005-1996; V-6 4.3 Eng.; Outlet (Lower)

## B61251

Chev; Astro; 2005-1996; V-6 4.3 Eng.; Inlet (Upper)  
 GMC; Safari; 2005-1996; V-6 4.3 Eng.; Inlet (Upper)

## B61252

Chev; C&K Pickup; 1997-1996; V-8 5.7 Eng.; Aux. Cooler Outlet (Driver Side); Exc 3500HD; W/16-Bolt Trans. Pan (M30)  
 Chev; Suburban; 1997-1996; V-8 5.7 Eng.; Aux. Cooler Outlet (Driver Side); W/16-Bolt Trans. Pan (M30)  
 Chev; Tahoe; 1997; V-8 5.7 Eng.; Aux. Cooler Outlet (Driver Side)  
 Chev; Tahoe; 1996; V-8 5.7 Eng.; Aux. Cooler Outlet (Driver Side); W/16-Bolt Trans. Pan (M30)  
 GMC; C&K Pickup; 1997-1996; V-8 5.7 Eng.; Aux. Cooler Outlet (Driver Side); Exc 3500HD; W/16-Bolt Trans. Pan (M30)  
 GMC; Suburban; 1997-1996; V-8 5.7 Eng.; Aux. Cooler Outlet (Driver Side); W/16-Bolt Trans. Pan (M30)  
 GMC; Yukon; 1997-1996; V-8 5.7 Eng.; Aux. Cooler Outlet (Driver Side); W/16-Bolt Trans. Pan (M30)

## B61253

Chev; C&K Pickup; 1996; V-8 5.7 Eng.; Aux. Cooler Outlet (Driver Side); Exc 3500HD; W/17-Bolt Trans. Pan (MT1)  
 Chev; Suburban; 1996; V-8 5.7 Eng.; Aux. Cooler Outlet (Driver Side); W/17-Bolt Trans. Pan (MT1)  
 Chev; Tahoe; 1996; V-8 5.7 Eng.; Aux. Cooler Outlet (Driver Side); W/17-Bolt Trans. Pan (MT1)  
 GMC; C&K Pickup; 1996; V-8 5.7 Eng.; Aux. Cooler Outlet (Driver Side); Exc 3500HD; W/17-Bolt Trans. Pan (MT1)  
 GMC; Suburban; 1996; V-8 5.7 Eng.; Aux. Cooler Outlet (Driver Side); W/17-Bolt Trans. Pan (MT1)  
 GMC; Yukon; 1996; V-8 5.7 Eng.; Aux. Cooler Outlet (Driver Side); W/17-Bolt Trans. Pan (MT1)



## Numerical Listing - Oil Cooler Assemblies & End Fittings

### B61254

Chev; C&K Pickup; 1996; V-8 7.4 Eng.; Aux. Cooler Outlet (Driver Side); Exc 3500HD  
 Chev; Suburban; 1996; V-8 7.4 Eng.; Aux. Cooler Outlet (Driver Side)  
 GMC; C&K Pickup; 1996; V-8 7.4 Eng.; Aux. Cooler Outlet (Driver Side); Exc 3500HD  
 GMC; Suburban; 1996; V-8 7.4 Eng.; Aux. Cooler Outlet (Driver Side)

### B61255

Jeep; Grand Cherokee; 1995-1993; V-8 5.2 Eng.; Outlet From Rad (Upper) To Trans. (Rear)

### B61256

Jeep; Cherokee; 1997-1994; 4-Cyl. 2.5 Eng.; Outlet Tube From Aux. Cooler (Lower) To Trans. (Rear)

### B61257

Jeep; Wrangler; 1995-1994; 4-Cyl. 2.5 Eng.; Outlet Tube (Pass. Side) To Trans. (Rear)

### B61258

Jeep; Wrangler; 1995-1994; 4-Cyl. 2.5 Eng.; Inlet Tube To Trans. (Front)

### B61259

Chev; Express; 2002-1998; V-8 5.0 Eng.; Outlet (Lower)  
 Chev; Express; 2002-1998; V-8 5.7 Eng.; Outlet (Lower); W/16-Bolt Trans. Pan (M30)  
 Chev; G Van; 1998; V-8 5.0 Eng.; Outlet (Lower)  
 Chev; G Van; 1998; V-8 5.7 Eng.; Outlet (Lower); W/16-Bolt Trans. Pan (M30)  
 GMC; Savana; 2002-1998; V-8 5.0 Eng.; Outlet (Lower)  
 GMC; Savana; 2002-1998; V-8 5.7 Eng.; Outlet (Lower); W/16-Bolt Trans. Pan (M30)

### B61260

Chev; Express; 2002-1997; V-8 5.7 Eng.; Inlet From Rad (Upper); W/17-Bolt Trans. Pan (MT1)  
 Chev; G Van; 1998-1997; V-8 5.7 Eng.; Inlet From Rad (Upper); W/17-Bolt Trans. Pan (MT1)  
 GMC; Savana; 2002-1997; V-8 5.7 Eng.; Inlet From Rad (Upper); W/17-Bolt Trans. Pan (MT1)

### B61261

Chev; Express; 2002-1997; V-8 5.7 Eng.; Aux. Cooler Outlet (Driver Side); W/17-Bolt Trans. Pan (MT1)  
 Chev; G Van; 1998-1997; V-8 5.7 Eng.; Aux. Cooler Outlet (Driver Side); W/17-Bolt Trans. Pan (MT1)  
 GMC; Savana; 2002-1997; V-8 5.7 Eng.; Aux. Cooler Outlet (Driver Side); W/17-Bolt Trans. Pan (MT1)

### B61262

Buick; Rainier; 2004; V-8 5.3 Eng.; Outlet (Lower)  
 Cad; Escalade; 2004-2002; V-8 5.3 Eng.; Outlet (Lower)  
 Cad; Escalade; 2004-2002; V-8 6.0 Eng.; Outlet (Lower)  
 Chev; Avalanche; 2003-2002; V-8 5.3 Eng.; Outlet (Lower)  
 Chev; Silverado Pickup; 2003-1999; V-6 4.3 Eng.; Outlet (Lower)  
 Chev; Silverado Pickup; 2003-1999; V-8 4.8 Eng.; Outlet (Lower)  
 Chev; Silverado Pickup; 2003-1999; V-8 5.3 Eng.; Outlet (Lower)  
 Chev; Silverado Pickup; 2003-2001; V-8 6.0 Eng.; Outlet (Lower); W/16-Bolt Trans. Pan (M30)  
 Chev; Suburban; 2003-2000; V-8 5.3 Eng.; Outlet (Lower)  
 Chev; Suburban; 2003-2001; V-8 6.0 Eng.; Outlet (Lower); W/16-Bolt Trans. Pan (M30)  
 Chev; Tahoe; 2003-2000; V-8 4.8 Eng.; Outlet (Lower)  
 Chev; Tahoe; 2003-2000; V-8 5.3 Eng.; Outlet (Lower)  
 Chev; Trailblazer; 2004-2003; V-8 5.3 Eng.; Outlet (Lower)  
 GMC; Envoy; 2004-2003; V-8 5.3 Eng.; Outlet (Lower)  
 GMC; Sierra Pickup; 2003-1999; V-6 4.3 Eng.; Outlet (Lower)  
 GMC; Sierra Pickup; 2003-1999; V-8 4.8 Eng.; Outlet (Lower)  
 GMC; Sierra Pickup; 2003-1999; V-8 5.3 Eng.; Outlet (Lower)  
 GMC; Sierra Pickup; 2003-2001; V-8 6.0 Eng.; Outlet (Lower); W/16-Bolt Trans. Pan (M30)  
 GMC; Yukon; 2003-2000; V-8 4.8 Eng.; Outlet (Lower)  
 GMC; Yukon; 2003-2000; V-8 5.3 Eng.; Outlet (Lower)  
 GMC; Yukon; 2003; V-8 6.0 Eng.; Outlet (Lower); W/16-Bolt Trans. Pan (M30)  
 GMC; Yukon; 2002-2001; V-8 6.0 Eng.; Outlet (Lower)

### B61263

Chev; Silverado Pickup; 2000-1999; V-8 5.3 Eng.; Aux. Cooler Inlet (Pass. Side); 2500  
 Chev; Silverado Pickup; 2003-2001; V-8 6.0 Eng.; Aux. Cooler Inlet (Driver Side); W/17-Bolt Trans. Pan (MT1)  
 Chev; Silverado Pickup; 2000; V-8 6.0 Eng.; Aux. Cooler Supply From Rad (Upper); 2nd Design  
 Chev; Suburban; 2000; V-8 5.3 Eng.; Aux. Cooler Inlet (Pass. Side); 2500  
 Chev; Suburban; 2003-2001; V-8 6.0 Eng.; Aux. Cooler Inlet (Driver Side); W/17-Bolt Trans. Pan (MT1)  
 Chev; Suburban; 2000; V-8 6.0 Eng.; Aux. Cooler Supply From Rad (Upper); 2nd Design  
 GMC; Sierra Pickup; 2000-1999; V-8 5.3 Eng.; Aux. Cooler Inlet (Pass. Side); 2500  
 GMC; Sierra Pickup; 2003-2001; V-8 6.0 Eng.; Aux. Cooler Inlet (Driver Side); W/17-Bolt Trans. Pan (MT1)  
 GMC; Sierra Pickup; 2000; V-8 6.0 Eng.; Aux. Cooler Supply From Rad (Upper); 2nd Design  
 GMC; Yukon; 2000; V-8 4.8 Eng.; Aux. Cooler Inlet (Pass. Side); 2500  
 GMC; Yukon; 2000; V-8 5.3 Eng.; Aux. Cooler Inlet (Pass. Side); 2500  
 GMC; Yukon; 2003; V-8 6.0 Eng.; Aux. Cooler Inlet (Driver Side); W/17-Bolt Trans. Pan (MT1)  
 GMC; Yukon; 2002-2001; V-8 6.0 Eng.; Aux. Cooler Inlet (Driver Side)  
 GMC; Yukon; 2000; V-8 6.0 Eng.; Aux. Cooler Supply From Rad (Upper); 2nd Design

### B61264

Buick; Rainier; 2004; V-8 5.3 Eng.; Aux. Cooler Inlet (Pass. Side)  
 Cad; Escalade; 2004-2002; V-8 5.3 Eng.; Aux. Cooler Inlet (Pass. Side)  
 Cad; Escalade; 2004-2002; V-8 6.0 Eng.; Aux. Cooler Inlet (Pass. Side)  
 Chev; Avalanche; 2003-2002; V-8 5.3 Eng.; Aux. Cooler Inlet (Pass. Side)  
 Chev; Silverado Pickup; 2003-1999; V-6 4.3 Eng.; Aux. Cooler Inlet (Pass. Side)  
 Chev; Silverado Pickup; 2003-1999; V-8 4.8 Eng.; Aux. Cooler Inlet (Pass. Side)  
 Chev; Silverado Pickup; 2003-2001; V-8 5.3 Eng.; Aux. Cooler Inlet (Pass. Side)  
 Chev; Silverado Pickup; 2000-1999; V-8 5.3 Eng.; Aux. Cooler Inlet (Pass. Side); 1500, 3500  
 Chev; Silverado Pickup; 2003-2001; V-8 6.0 Eng.; Aux. Cooler Inlet (Pass. Side); W/16-Bolt Trans. Pan (M30)  
 Chev; Suburban; 2003-2001; V-8 5.3 Eng.; Aux. Cooler Inlet (Pass. Side)  
 Chev; Suburban; 2000; V-8 5.3 Eng.; Aux. Cooler Inlet (Pass. Side); 1500  
 Chev; Suburban; 2003-2001; V-8 6.0 Eng.; Aux. Cooler Inlet (Pass. Side); W/16-Bolt Trans. Pan (M30)  
 Chev; Tahoe; 2003-2000; V-8 4.8 Eng.; Aux. Cooler Inlet (Pass. Side)  
 Chev; Tahoe; 2003-2000; V-8 5.3 Eng.; Aux. Cooler Inlet (Pass. Side)  
 Chev; Trailblazer; 2004-2003; V-8 5.3 Eng.; Aux. Cooler Inlet (Pass. Side)  
 GMC; Envoy; 2004-2003; V-8 5.3 Eng.; Aux. Cooler Inlet (Pass. Side)  
 GMC; Sierra Pickup; 2003-1999; V-6 4.3 Eng.; Aux. Cooler Inlet (Pass. Side)  
 GMC; Sierra Pickup; 2003-1999; V-8 4.8 Eng.; Aux. Cooler Inlet (Pass. Side)  
 GMC; Sierra Pickup; 2003-2001; V-8 5.3 Eng.; Aux. Cooler Inlet (Pass. Side)  
 GMC; Sierra Pickup; 2000-1999; V-8 5.3 Eng.; Aux. Cooler Inlet (Pass. Side); 1500, 3500  
 GMC; Sierra Pickup; 2003-2001; V-8 6.0 Eng.; Aux. Cooler Inlet (Pass. Side); W/16-Bolt Trans. Pan (M30)  
 GMC; Yukon; 2003-2001; V-8 4.8 Eng.; Aux. Cooler Inlet (Pass. Side)  
 GMC; Yukon; 2000; V-8 4.8 Eng.; Aux. Cooler Inlet (Pass. Side); 1500  
 GMC; Yukon; 2003-2001; V-8 5.3 Eng.; Aux. Cooler Inlet (Pass. Side)  
 GMC; Yukon; 2000; V-8 5.3 Eng.; Aux. Cooler Inlet (Pass. Side); 1500  
 GMC; Yukon; 2003; V-8 6.0 Eng.; Aux. Cooler Inlet (Pass. Side); W/16-Bolt Trans. Pan (M30)

### B61265

Chev; Silverado Pickup; 2000-1999; V-8 5.3 Eng.; Aux. Cooler Outlet (Driver Side); 2500  
 Chev; Suburban; 2000; V-8 5.3 Eng.; Aux. Cooler Outlet (Driver Side); 2500  
 GMC; Sierra Pickup; 2000-1999; V-8 5.3 Eng.; Aux. Cooler Outlet (Driver Side); 2500  
 GMC; Yukon; 2000; V-8 4.8 Eng.; Aux. Cooler Outlet (Driver Side); 2500  
 GMC; Yukon; 2000; V-8 5.3 Eng.; Aux. Cooler Outlet (Driver Side); 2500

### B61266

Buick; Rainier; 2004; V-8 5.3 Eng.; Aux. Cooler Outlet (Driver Side)  
 Cad; Escalade; 2004-2002; V-8 5.3 Eng.; Aux. Cooler Outlet (Driver Side)  
 Cad; Escalade; 2004-2002; V-8 6.0 Eng.; Aux. Cooler Outlet (Driver Side)  
 Chev; Avalanche; 2003-2002; V-8 5.3 Eng.; Aux. Cooler Outlet (Driver Side)

## Numerical Listing - Oil Cooler Assemblies & End Fittings

### B61266 - Continued

Chev; Silverado Pickup; 2003-1999; V-6 4.3 Eng.; Aux. Cooler Outlet (Driver Side)  
 Chev; Silverado Pickup; 2003-1999; V-8 4.8 Eng.; Aux. Cooler Outlet (Driver Side)  
 Chev; Silverado Pickup; 2003-2001; V-8 5.3 Eng.; Aux. Cooler Outlet (Driver Side)  
 Chev; Silverado Pickup; 2000-1999; V-8 5.3 Eng.; Aux. Cooler Outlet (Driver Side); 1500, 3500  
 Chev; Silverado Pickup; 2003-2001; V-8 6.0 Eng.; Aux. Cooler Outlet (Driver Side); W/16-Bolt Trans. Pan (M30)  
 Chev; Suburban; 2003-2001; V-8 5.3 Eng.; Aux. Cooler Outlet (Driver Side)  
 Chev; Suburban; 2000; V-8 5.3 Eng.; Aux. Cooler Outlet (Driver Side); 1500  
 Chev; Suburban; 2003-2001; V-8 6.0 Eng.; Aux. Cooler Outlet (Driver Side); W/16-Bolt Trans. Pan (M30)  
 Chev; Tahoe; 2003-2000; V-8 4.8 Eng.; Aux. Cooler Outlet (Driver Side)  
 Chev; Tahoe; 2003-2000; V-8 5.3 Eng.; Aux. Cooler Outlet (Driver Side)  
 Chev; Trailblazer; 2004-2003; V-8 5.3 Eng.; Aux. Cooler Outlet (Driver Side)  
 GMC; Envoy; 2004-2003; V-8 5.3 Eng.; Aux. Cooler Outlet (Driver Side)  
 GMC; Sierra Pickup; 2003-1999; V-6 4.3 Eng.; Aux. Cooler Outlet (Driver Side)  
 GMC; Sierra Pickup; 2003-1999; V-8 4.8 Eng.; Aux. Cooler Outlet (Driver Side)  
 GMC; Sierra Pickup; 2003-2001; V-8 5.3 Eng.; Aux. Cooler Outlet (Driver Side)  
 GMC; Sierra Pickup; 2000-1999; V-8 5.3 Eng.; Aux. Cooler Outlet (Driver Side); 1500, 3500  
 GMC; Sierra Pickup; 2003; V-8 6.0 Eng.; Aux. Cooler Inlet (Driver Side); W/16-Bolt Trans. Pan (M30)  
 GMC; Sierra Pickup; 2002-2001; V-8 6.0 Eng.; Aux. Cooler Outlet (Driver Side); W/16-Bolt Trans. Pan (M30)  
 GMC; Yukon; 2003-2001; V-8 4.8 Eng.; Aux. Cooler Outlet (Driver Side)  
 GMC; Yukon; 2000; V-8 4.8 Eng.; Aux. Cooler Outlet (Driver Side); 1500  
 GMC; Yukon; 2003-2001; V-8 5.3 Eng.; Aux. Cooler Outlet (Driver Side)  
 GMC; Yukon; 2000; V-8 5.3 Eng.; Aux. Cooler Outlet (Driver Side); 1500  
 GMC; Yukon; 2003; V-8 6.0 Eng.; Aux. Cooler Inlet (Driver Side); W/16-Bolt Trans. Pan (M30)

### B61267

Buick; Rainier; 2004; V-8 5.3 Eng.; Inlet (Upper); W/O Aux. Cooler  
 Cad; Escalade; 2004-2002; V-8 5.3 Eng.; Inlet (Upper); W/O Aux. Cooler  
 Cad; Escalade; 2004-2002; V-8 6.0 Eng.; Inlet (Upper); W/O Aux. Cooler  
 Chev; Avalanche; 2003-2002; V-8 5.3 Eng.; Inlet (Upper); W/O Aux. Cooler  
 Chev; Silverado Pickup; 2003-1999; V-6 4.3 Eng.; Inlet (Upper); W/O Aux. Cooler  
 Chev; Silverado Pickup; 2003-1999; V-8 4.8 Eng.; Inlet (Upper); W/O Aux. Cooler  
 Chev; Silverado Pickup; 2003-1999; V-8 5.3 Eng.; Inlet (Upper); W/O Aux. Cooler  
 Chev; Silverado Pickup; 2003-2001; V-8 6.0 Eng.; Inlet (Upper); W/16-Bolt Trans. Pan (M30); W/O Aux. Cooler  
 Chev; Suburban; 2003-2000; V-8 5.3 Eng.; Inlet (Upper); W/O Aux. Cooler  
 Chev; Suburban; 2003-2001; V-8 6.0 Eng.; Inlet (Upper); W/16-Bolt Trans. Pan (M30); W/O Aux. Cooler  
 Chev; Tahoe; 2003-2000; V-8 4.8 Eng.; Inlet (Upper); W/O Aux. Cooler  
 Chev; Tahoe; 2003-2000; V-8 5.3 Eng.; Inlet (Upper); W/O Aux. Cooler  
 Chev; Trailblazer; 2004-2003; V-8 5.3 Eng.; Inlet (Upper); W/O Aux. Cooler  
 GMC; Envoy; 2004-2003; V-8 5.3 Eng.; Inlet (Upper); W/O Aux. Cooler  
 GMC; Sierra Pickup; 2003-1999; V-6 4.3 Eng.; Inlet (Upper); W/O Aux. Cooler  
 GMC; Sierra Pickup; 2003-1999; V-8 4.8 Eng.; Inlet (Upper); W/O Aux. Cooler  
 GMC; Sierra Pickup; 2003-1999; V-8 5.3 Eng.; Inlet (Upper); W/O Aux. Cooler  
 GMC; Sierra Pickup; 2003; V-8 6.0 Eng.; Inlet (Upper); W/16-Bolt Trans. Pan (M30); W/O Aux. Cooler  
 GMC; Sierra Pickup; 2002-2001; V-8 6.0 Eng.; Inlet (Upper); W/O Aux. Cooler  
 GMC; Yukon; 2003-2000; V-8 4.8 Eng.; Inlet (Upper); W/O Aux. Cooler  
 GMC; Yukon; 2003-2000; V-8 5.3 Eng.; Inlet (Upper); W/O Aux. Cooler  
 GMC; Yukon; 2003; V-8 6.0 Eng.; Inlet (Upper); W/16-Bolt Trans. Pan (M30); W/O Aux. Cooler  
 GMC; Yukon; 2002-2001; V-8 6.0 Eng.; Inlet (Upper); W/O Aux. Cooler

### B61268

Chev; Express; 1997; V-8 5.0 Eng.; Outlet (Lower)  
 Chev; Express; 1997; V-8 5.7 Eng.; Outlet (Lower)  
 Chev; G Van; 1997; V-8 5.0 Eng.; Outlet (Lower)

### B61268 - Continued

Chev; G Van; 1997; V-8 5.7 Eng.; Outlet (Lower)  
 GMC; Savana; 1997; V-8 5.0 Eng.; Outlet (Lower)  
 GMC; Savana; 1997; V-8 5.7 Eng.; Outlet (Lower)

### B61269

Chev; Express; 1997; V-8 5.0 Eng.; Inlet (Upper)  
 Chev; Express; 1997; V-8 5.7 Eng.; Inlet (Upper); W/16-Bolt Trans. Pan (M30)  
 Chev; G Van; 1997; V-8 5.0 Eng.; Inlet (Upper)  
 Chev; G Van; 1997; V-8 5.7 Eng.; Inlet (Upper); W/16-Bolt Trans. Pan (M30)  
 GMC; Savana; 1997; V-8 5.0 Eng.; Inlet (Upper)  
 GMC; Savana; 1997; V-8 5.7 Eng.; Inlet (Upper); W/16-Bolt Trans. Pan (M30)

### B61270

Chev; Avalanche; 2003-2002; V-8 8.1 Eng.; Inlet From Rad (Lower)  
 Chev; Silverado Pickup; 2003-2001; V-8 8.1 Eng.; Inlet From Rad (Lower)  
 Chev; Suburban; 2003-2001; V-8 8.1 Eng.; Inlet From Rad (Lower)  
 GMC; Sierra Pickup; 2003-2001; V-8 8.1 Eng.; Inlet From Rad (Lower)  
 GMC; Yukon; 2003-2001; V-8 8.1 Eng.; Inlet From Rad (Lower)

### B61272

Buick; Park Ave.; 1999-1997; V-6 3.8 Eng.; Outlet (Lower)

### B61273

Buick; Park Ave.; 1999-1997; V-6 3.8 Eng.; Inlet (Upper)

### B61275

Ford; Excursion; 2001; V-8 5.4 Eng.; Aux. Cooler Outlet (Pass. Side); 2-24 & Older  
 Ford; Excursion; 2000; V-8 5.4 Eng.; Aux. Cooler Outlet (Pass. Side)  
 Ford; Excursion; 2001; V-8 7.3 Diesel Eng.; Aux. Cooler Outlet (Pass. Side); 2-24 & Older  
 Ford; Excursion; 2000; V-8 7.3 Diesel Eng.; Aux. Cooler Outlet (Pass. Side)  
 Ford; Excursion; 2001; V-10 6.8 Eng.; Aux. Cooler Outlet (Pass. Side); 2-24 & Older  
 Ford; Excursion; 2000; V-10 6.8 Eng.; Aux. Cooler Outlet (Pass. Side)  
 Ford; Super Duty Pickup; 2001; V-8 5.4 Eng.; Aux. Cooler Outlet (Pass. Side); 2-24 & Older  
 Ford; Super Duty Pickup; 2000-1999; V-8 5.4 Eng.; Aux. Cooler Outlet (Pass. Side)  
 Ford; Super Duty Pickup; 2001; V-8 7.3 Diesel Eng.; Aux. Cooler Outlet (Pass. Side); 2-24 & Older  
 Ford; Super Duty Pickup; 2000-1999; V-8 7.3 Diesel Eng.; Aux. Cooler Outlet (Pass. Side)  
 Ford; Super Duty Pickup; 2001; V-10 6.8 Eng.; Aux. Cooler Outlet (Pass. Side); 2-24 & Older  
 Ford; Super Duty Pickup; 2000-1999; V-10 6.8 Eng.; Aux. Cooler Outlet (Pass. Side)

### B61277

Ford; Explorer; 2001-1997; V-6 4.0 Eng.; Inlet From Rad (Lower); W/O Aux. Cooler  
 Ford; Ranger; 2003-1998; V-6 4.0 Eng.; Inlet To Trans. (Upper); W/O Aux. Cooler  
 Merc; Mountaineer; 2001-1998; V-6 4.0 Eng.; Inlet From Rad (Lower); W/O Aux. Cooler

### B61278

Ford; Explorer; 2001-1997; V-6 4.0 Eng.; Inlet To Trans. (Upper); W/Aux. Cooler  
 Ford; Ranger; 2003-1998; V-6 4.0 Eng.; Inlet To Trans. (Upper); W/Aux. Cooler  
 Merc; Mountaineer; 2001-1998; V-6 4.0 Eng.; Inlet To Trans. (Upper); W/Aux. Cooler

### B61279

Ford; Explorer; 2001-1997; V-6 4.0 Eng.; Aux. Cooler Outlet (Lower)  
 Ford; Ranger; 2003-1998; V-6 3.0 Eng.; Aux. Cooler Outlet Tube (Lower)  
 Ford; Ranger; 2003-1998; V-6 4.0 Eng.; Aux. Cooler Outlet Tube (Lower)  
 Merc; Mountaineer; 2001-1998; V-6 4.0 Eng.; Aux. Cooler Outlet (Lower)

### B61280

Ford; Explorer; 2001-1997; V-6 4.0 Eng.; Outlet To Trans. (Lower)

# Numerical Listing - Oil Cooler Assemblies & End Fittings

## B61280 - Continued

Ford; Ranger; 2003-1998; V-6 4.0 Eng.; Outlet To Trans. (Lower)  
 Merc; Mountaineer; 2001-1998; V-6 4.0 Eng.; Outlet To Trans. (Lower)

## B61281

Ford; Explorer; 2001-1998; V-8 5.0 Eng.; Outlet From Rad (Upper)  
 Merc; Mountaineer; 2001-1998; V-8 5.0 Eng.; Outlet From Rad (Upper)

## B61282

Ford; Expedition; 2001; V-8 5.4 Eng.; Outlet From Rad (Upper)  
 Linc; Navigator; 2002-2001; V-8 5.4 Eng.; Outlet From Rad (Upper)

## B61283

Ford; Excursion; 2002-2000; V-8 7.3 Diesel Eng.; Inlet To Trans. (Rear)  
 Ford; Super Duty Pickup; 2002-1999; V-8 7.3 Diesel Eng.; Inlet To Trans. (Rear)

## B61284

Ford; Excursion; 2000; V-8 7.3 Diesel Eng.; Outlet To Trans. (Front); 2-5 & Older  
 Ford; Super Duty Pickup; 2000; V-8 7.3 Diesel Eng.; Outlet To Trans. (Front); 2-5 & Older  
 Ford; Super Duty Pickup; 1999; V-8 7.3 Diesel Eng.; Outlet To Trans. (Front)

## B61285

Ford; Excursion; 2000; V-8 5.4 Eng.; Outlet To Trans. (Front); 2-6 & Newer  
 Ford; Excursion; 2002-2001; V-8 7.3 Diesel Eng.; Outlet To Trans. (Front)  
 Ford; Excursion; 2000; V-8 7.3 Diesel Eng.; Outlet To Trans. (Front); 2-6 & Newer  
 Ford; Excursion; 2000; V-10 6.8 Eng.; Outlet To Trans. (Front); 2-6 & Newer  
 Ford; Super Duty Pickup; 2000; V-8 5.4 Eng.; Outlet To Trans. (Front); 2-6 & Newer  
 Ford; Super Duty Pickup; 2002-2001; V-8 7.3 Diesel Eng.; Outlet To Trans. (Front)  
 Ford; Super Duty Pickup; 2000; V-8 7.3 Diesel Eng.; Outlet To Trans. (Front); 2-6 & Newer  
 Ford; Super Duty Pickup; 2000; V-10 6.8 Eng.; Outlet To Trans. (Front); 2-6 & Newer

## B61286

Ford; Ranger; 2003-1998; V-6 3.0 Eng.; Inlet To Trans. (Upper)

## B61287

Ford; Ranger; 2003-1998; V-6 3.0 Eng.; Outlet To Trans. (Lower)

## B61288

Ford; Explorer; 2001-1998; V-8 5.0 Eng.; Inlet To Trans. (Upper)  
 Merc; Mountaineer; 2001-1998; V-8 5.0 Eng.; Inlet To Trans. (Upper)

## B61289

Ford; Explorer; 2001-1998; V-8 5.0 Eng.; Aux. Cooler Outlet (Lower)  
 Merc; Mountaineer; 2001-1998; V-8 5.0 Eng.; Aux. Cooler Outlet (Lower)

## B61290

Ford; Ranger; 2001-1998; 4-Cyl. 2.5 Eng.; Outlet To Trans. (Lower)

## B61291

Ford; Ranger; 2001-1998; 4-Cyl. 2.5 Eng.; Inlet To Trans. (Upper)

## B61292

Buick; Lesabre; 2005-2000; V-6 3.8 Eng.; Outlet (Lower)  
 Buick; Park Ave.; 2005-2000; V-6 3.8 Eng.; Outlet (Lower)  
 Pont; Bonneville; 2005-2002; V-6 3.8 Eng.; Outlet (Lower)

## B61293

Buick; Lesabre; 2005-2000; V-6 3.8 Eng.; Inlet (Upper)  
 Buick; Park Ave.; 2005-2000; V-6 3.8 Eng.; Inlet (Upper)  
 Pont; Bonneville; 2005-2002; V-6 3.8 Eng.; Inlet (Upper)

## B61294

Chev; Camaro; 2002-1998; V-8 5.7 Eng.; Outlet From Rad (Lower)  
 Pont; Firebird; 2002-1998; V-8 5.7 Eng.; Outlet From Rad (Lower)

## B61295

Chev; Camaro; 2002-1998; V-8 5.7 Eng.; Inlet To Trans. (Lower)  
 Pont; Firebird; 2002-1998; V-8 5.7 Eng.; Inlet To Trans. (Lower)

## B61296

Chev; Camaro; 2002-1998; V-6 3.8 Eng.; Outlet From Rad (Lower)  
 Pont; Firebird; 2002-1998; V-6 3.8 Eng.; Outlet From Rad (Lower)

## B61297

Chev; Camaro; 2002-1998; V-6 3.8 Eng.; Inlet To Trans. (Lower)  
 Pont; Firebird; 2002-1998; V-6 3.8 Eng.; Inlet To Trans. (Lower)

## B61305

Ford; Super Duty Pickup; 2000; V-8 5.4 Eng.; Outlet To Trans. (Front); 2-5 & Older  
 Ford; Super Duty Pickup; 1999; V-8 5.4 Eng.; Outlet To Trans. (Front)  
 Ford; Super Duty Pickup; 2000; V-10 6.8 Eng.; Outlet To Trans. (Front); 2-5 & Older  
 Ford; Super Duty Pickup; 1999; V-10 6.8 Eng.; Outlet To Trans. (Front)

## B61306

Ford; E Van; 2005-1999; V-8 5.4 Eng.; Inlet To Trans. (Rear); W/4R100 Trans.  
 Ford; E Van; 1998-1997; V-8 5.4 Eng.; Inlet To Trans. (Rear); W/E4OD/4R100 Trans.  
 Ford; Super Duty Van; 2005-1999; V-8 5.4 Eng.; Inlet To Trans. (Rear); W/4R100 Trans.  
 Ford; Super Duty Van; 1998-1997; V-8 5.4 Eng.; Inlet To Trans. (Rear); W/E4OD/4R100 Trans.

## B61307

Ford; E Van; 2005-1997; V-8 4.6 Eng.; Inlet (Upper)  
 Ford; E Van; 1998-1997; V-8 5.4 Eng.; Inlet (Upper); W/4R70W Trans.  
 Ford; Super Duty Van; 2004-2003; V-8 4.6 Eng.; Inlet (Upper)  
 Ford; Super Duty Van; 1998-1997; V-8 5.4 Eng.; Inlet (Upper); W/4R70W Trans.

## B61308

Ford; E Van; 2003-1997; V-6 4.2 Eng.; Inlet (Upper)  
 Ford; Super Duty Van; 2003-2001; V-6 4.2 Eng.; Inlet (Upper)

## B61309

Ford; E Van; 2005-1997; V-8 4.6 Eng.; Outlet (Lower)  
 Ford; Super Duty Van; 2004-2003; V-8 4.6 Eng.; Outlet (Lower)

## B61310

Ford; E Van; 2005-1999; V-8 5.4 Eng.; Outlet To Trans. (Front); W/4R100 Trans.  
 Ford; E Van; 1998-1997; V-8 5.4 Eng.; Outlet To Trans. (Front); W/E4OD/4R100 Trans.  
 Ford; Super Duty Van; 2005-1999; V-8 5.4 Eng.; Outlet To Trans. (Front); W/4R100 Trans.  
 Ford; Super Duty Van; 1998-1997; V-8 5.4 Eng.; Outlet To Trans. (Front); W/E4OD/4R100 Trans.

## B61311

Chev; Express; 2002-1998; V-8 5.0 Eng.; Inlet (Upper)  
 Chev; Express; 2002-1998; V-8 5.7 Eng.; Inlet From Rad (Upper); W/16-Bolt Trans. Pan (M30)  
 Chev; G Van; 1998; V-8 5.0 Eng.; Inlet (Upper)  
 Chev; G Van; 1998; V-8 5.7 Eng.; Inlet From Rad (Upper); W/16-Bolt Trans. Pan (M30)  
 GMC; Savana; 2002-1998; V-8 5.0 Eng.; Inlet (Upper)  
 GMC; Savana; 2002-1998; V-8 5.7 Eng.; Inlet From Rad (Upper); W/16-Bolt Trans. Pan (M30)

## B61312

Chev; Silverado Pickup; 2003-2001; V-8 6.0 Eng.; Outlet (Lower); W/17-Bolt Trans. Pan (MT1)  
 Chev; Silverado Pickup; 2000; V-8 6.0 Eng.; Outlet From Rad (Lower); 2nd Design

# Numerical Listing - Oil Cooler Assemblies & End Fittings

Product Section

Troubleshooting

EOC Applications

TOC Applications

Numerical Listing

Manufacturers' Part Numbers

End Fittings

Illustrations

## B61312 - Continued

Chev; Suburban; 2003-2001; V-8 6.0 Eng.; Outlet (Lower); W/17-Bolt Trans. Pan (MT1)  
 Chev; Suburban; 2000; V-8 6.0 Eng.; Outlet From Rad (Lower); 2nd Design  
 GMC; Sierra Pickup; 2003-2001; V-8 6.0 Eng.; Outlet (Lower); W/17-Bolt Trans. Pan (MT1)  
 GMC; Sierra Pickup; 2000; V-8 6.0 Eng.; Outlet From Rad (Lower); 2nd Design  
 GMC; Yukon; 2003; V-8 6.0 Eng.; Outlet (Lower); W/17-Bolt Trans. Pan (MT1)  
 GMC; Yukon; 2002-2001; V-8 6.0 Eng.; Aux. Cooler Outlet (Pass. Side)  
 GMC; Yukon; 2000; V-8 6.0 Eng.; Outlet From Rad (Lower); 2nd Design

## B61313

Chev; Silverado Pickup; 2003-2001; V-8 6.0 Eng.; Aux. Cooler Outlet (Pass. Side); W/17-Bolt Trans. Pan (MT1)  
 Chev; Silverado Pickup; 2000-1999; V-8 6.0 Eng.; Aux. Cooler Inlet (Driver Side)  
 Chev; Suburban; 2003-2001; V-8 6.0 Eng.; Aux. Cooler Outlet (Pass. Side); W/17-Bolt Trans. Pan (MT1)  
 Chev; Suburban; 2000; V-8 6.0 Eng.; Aux. Cooler Inlet (Driver Side)  
 GMC; Sierra Pickup; 2003-2001; V-8 6.0 Eng.; Aux. Cooler Outlet (Pass. Side); W/17-Bolt Trans. Pan (MT1)  
 GMC; Sierra Pickup; 2000-1999; V-8 6.0 Eng.; Aux. Cooler Inlet (Driver Side)  
 GMC; Yukon; 2003; V-8 6.0 Eng.; Aux. Cooler Inlet (Pass. Side); W/17-Bolt Trans. Pan (MT1)  
 GMC; Yukon; 2000; V-8 6.0 Eng.; Aux. Cooler Inlet (Driver Side)

## B64200

Chev; Astro; 1993-1990; V-6 4.3 Eng.; Inlet (Upper); W/2WD  
 Chev; Astro; 1989-1985; V-6 4.3 Eng.; Inlet (Upper)  
 GMC; Safari; 1993-1990; V-6 4.3 Eng.; Inlet (Upper); W/2WD  
 GMC; Safari; 1989-1985; V-6 4.3 Eng.; Inlet (Upper)

## B64201

Chev; Astro; 1993-1990; V-6 4.3 Eng.; Outlet (Lower); W/2WD  
 Chev; Astro; 1989-1985; V-6 4.3 Eng.; Outlet (Lower)  
 GMC; Safari; 1993-1990; V-6 4.3 Eng.; Outlet (Lower); W/2WD  
 GMC; Safari; 1989-1985; V-6 4.3 Eng.; Outlet (Lower)

## B64202

Chev; G Van; 1996-1994; V-8 6.5 Diesel Eng.; Inlet (Lower)  
 GMC; G Van; 1996-1994; V-8 6.5 Diesel Eng.; Inlet (Lower)

## B64203

Chev; G Van; 1996-1994; V-8 6.5 Diesel Eng.; Outlet (Upper)  
 GMC; G Van; 1996-1994; V-8 6.5 Diesel Eng.; Outlet (Upper)

## B64204

Chev; Blazer; 1995; V-6 4.3 Eng.; Inlet (Upper); W/2WD  
 Chev; S Pickup; 1995-1994; V-6 4.3 Eng.; Inlet (Upper); W/2WD  
 GMC; Jimmy; 1995; V-6 4.3 Eng.; Inlet (Upper); W/2WD  
 GMC; Sonoma; 1995-1994; V-6 4.3 Eng.; Inlet (Upper); W/2WD

## B64205

Chev; Blazer; 1995; V-6 4.3 Eng.; Outlet (Lower); W/2WD  
 Chev; S Pickup; 1995-1994; V-6 4.3 Eng.; Outlet (Lower); W/2WD  
 GMC; Jimmy; 1995; V-6 4.3 Eng.; Outlet (Lower); W/2WD  
 GMC; Sonoma; 1995-1994; V-6 4.3 Eng.; Outlet (Lower); W/2WD

## B64206

Chev; G Van; 1991-1985; V-8 6.2 Diesel Eng.; Inlet (Upper)  
 GMC; G Van; 1991-1985; V-8 6.2 Diesel Eng.; Inlet (Upper)

## B64207

Chev; G Van; 1991-1985; V-8 6.2 Diesel Eng.; Outlet (Lower)  
 GMC; G Van; 1991-1985; V-8 6.2 Diesel Eng.; Outlet (Lower)

## B64208

Chev; Blazer Full Size; 1994; V-8 5.7 Eng.; Inlet (Upper); W/4WD  
 Chev; C&K Pickup; 1995; V-8 5.7 Eng.; Inlet (Upper); W/4WD  
 Chev; C&K Pickup; 1994; V-8 5.7 Eng.; Inlet (Upper); W/4WD; W/Chassis Cab

## B64208 - Continued

Chev; Suburban; 1995-1994; V-8 5.7 Eng.; Inlet (Upper); W/4WD  
 Chev; Tahoe; 1995; V-8 5.7 Eng.; Inlet (Upper); W/4WD  
 GMC; C&K Pickup; 1995; V-8 5.7 Eng.; Inlet (Upper); W/4WD  
 GMC; C&K Pickup; 1994; V-8 5.7 Eng.; Inlet (Upper); W/4WD; W/Chassis Cab  
 GMC; Suburban; 1995-1994; V-8 5.7 Eng.; Inlet (Upper); W/4WD  
 GMC; Yukon; 1995-1994; V-8 5.7 Eng.; Inlet (Upper); W/4WD

## B64209

Chev; Blazer Full Size; 1994; V-8 5.7 Eng.; Outlet (Lower); W/4WD  
 Chev; C&K Pickup; 1995; V-8 5.7 Eng.; Outlet (Lower); W/4WD  
 Chev; C&K Pickup; 1994; V-8 5.7 Eng.; Outlet (Lower); W/4WD; W/Chassis Cab  
 Chev; Suburban; 1995-1994; V-8 5.7 Eng.; Outlet (Lower); W/4WD  
 Chev; Tahoe; 1995; V-8 5.7 Eng.; Outlet (Lower); W/4WD  
 GMC; C&K Pickup; 1995; V-8 5.7 Eng.; Outlet (Lower); W/4WD  
 GMC; C&K Pickup; 1994; V-8 5.7 Eng.; Outlet (Lower); W/4WD; W/Chassis Cab  
 GMC; Suburban; 1995-1994; V-8 5.7 Eng.; Outlet (Lower); W/4WD  
 GMC; Yukon; 1995-1994; V-8 5.7 Eng.; Outlet (Lower); W/4WD

## B64210

Cad; Escalade; 2000-1999; V-8 5.7 Eng.; Inlet (Lower); W/4WD  
 Chev; C&K Pickup; 1999-1996; V-8 5.0 Eng.; Inlet (Lower); W/140A Alt; W/4WD  
 Chev; C&K Pickup; 2000-1996; V-8 5.7 Eng.; Inlet (Lower); W/4WD  
 Chev; Suburban; 1999-1996; V-8 5.7 Eng.; Inlet (Lower); W/4WD  
 Chev; Tahoe; 2000-1996; V-8 5.7 Eng.; Inlet (Lower); W/4WD  
 GMC; C&K Pickup; 1999-1996; V-8 5.0 Eng.; Inlet (Lower); W/140A Alt; W/4WD  
 GMC; C&K Pickup; 2000-1996; V-8 5.7 Eng.; Inlet (Lower); W/4WD  
 GMC; Suburban; 1999-1996; V-8 5.7 Eng.; Inlet (Lower); W/4WD  
 GMC; Yukon; 2000-1996; V-8 5.7 Eng.; Inlet (Lower); W/4WD

## B64211

Cad; Escalade; 2000-1999; V-8 5.7 Eng.; Outlet (Upper); W/4WD  
 Chev; C&K Pickup; 1999-1996; V-8 5.0 Eng.; Outlet (Upper); W/140A Alt; W/4WD  
 Chev; C&K Pickup; 2000-1996; V-8 5.7 Eng.; Outlet (Upper); W/4WD  
 Chev; Suburban; 1999-1996; V-8 5.7 Eng.; Outlet (Upper); W/4WD  
 Chev; Tahoe; 2000-1996; V-8 5.7 Eng.; Outlet (Upper); W/4WD  
 GMC; C&K Pickup; 1999-1996; V-8 5.0 Eng.; Outlet (Upper); W/140A Alt; W/4WD  
 GMC; C&K Pickup; 2000-1996; V-8 5.7 Eng.; Outlet (Upper); W/4WD  
 GMC; Suburban; 1999-1996; V-8 5.7 Eng.; Outlet (Upper); W/4WD  
 GMC; Yukon; 2000-1996; V-8 5.7 Eng.; Outlet (Upper); W/4WD

## B64212

Chev; C&K Pickup; 1995-1994; V-8 7.4 Eng.; Inlet (Lower); W/O Aux. Cooler  
 Chev; Suburban; 1995-1994; V-8 7.4 Eng.; Inlet (Lower); W/O Aux. Cooler  
 GMC; C&K Pickup; 1995-1994; V-8 7.4 Eng.; Inlet (Lower); W/O Aux. Cooler  
 GMC; Suburban; 1995-1994; V-8 7.4 Eng.; Inlet (Lower); W/O Aux. Cooler

## B64213

Chev; C&K Pickup; 1995-1994; V-8 7.4 Eng.; Outlet (Upper); W/O Aux. Cooler  
 Chev; Suburban; 1995-1994; V-8 7.4 Eng.; Outlet (Upper); W/O Aux. Cooler  
 GMC; C&K Pickup; 1995-1994; V-8 7.4 Eng.; Outlet (Upper); W/O Aux. Cooler  
 GMC; Suburban; 1995-1994; V-8 7.4 Eng.; Outlet (Upper); W/O Aux. Cooler

## B64214

Chev; C&K Pickup; 1997; V-8 6.5 Diesel Eng.; Inlet (Driver Side); W/1/2" Tubing; Exc 3500HD  
 Chev; C&K Pickup; 1996-1995; V-8 6.5 Diesel Eng.; Inlet (Driver Side); Exc 3500HD  
 Chev; Suburban; 1997; V-8 6.5 Diesel Eng.; Inlet (Driver Side); W/1/2" Tubing  
 Chev; Suburban; 1996-1995; V-8 6.5 Diesel Eng.; Inlet (Driver Side)  
 Chev; Tahoe; 1997; V-8 6.5 Diesel Eng.; Inlet (Driver Side); W/1/2" Tubing  
 Chev; Tahoe; 1996-1995; V-8 6.5 Diesel Eng.; Inlet (Driver Side)  
 GMC; C&K Pickup; 1997; V-8 6.5 Diesel Eng.; Inlet (Driver Side); W/1/2" Tubing; Exc 3500HD

# Numerical Listing - Oil Cooler Assemblies & End Fittings

## B64214 - Continued

GMC; C&K Pickup; 1996-1995; V-8 6.5 Diesel Eng.; Inlet (Driver Side); Exc 3500HD  
 GMC; Suburban; 1997; V-8 6.5 Diesel Eng.; Inlet (Driver Side); W/1/2" Tubing  
 GMC; Suburban; 1996-1995; V-8 6.5 Diesel Eng.; Inlet (Driver Side)  
 GMC; Yukon; 1997; V-8 6.5 Diesel Eng.; Inlet (Driver Side); W/1/2" Tubing  
 GMC; Yukon; 1996-1995; V-8 6.5 Diesel Eng.; Inlet (Driver Side)

## B64215

Chev; C&K Pickup; 1997; V-8 6.5 Diesel Eng.; Outlet (Pass. Side); W/1/2" Tubing; Exc 3500HD  
 Chev; C&K Pickup; 1996-1995; V-8 6.5 Diesel Eng.; Outlet (Pass. Side); Exc 3500HD  
 Chev; Suburban; 1997; V-8 6.5 Diesel Eng.; Outlet (Pass. Side); W/1/2" Tubing  
 Chev; Suburban; 1996-1995; V-8 6.5 Diesel Eng.; Outlet (Pass. Side)  
 Chev; Tahoe; 1997; V-8 6.5 Diesel Eng.; Outlet (Pass. Side); W/1/2" Tubing  
 Chev; Tahoe; 1996-1995; V-8 6.5 Diesel Eng.; Outlet (Pass. Side)  
 GMC; C&K Pickup; 1997; V-8 6.5 Diesel Eng.; Outlet (Pass. Side); W/1/2" Tubing; Exc 3500HD  
 GMC; C&K Pickup; 1996-1995; V-8 6.5 Diesel Eng.; Outlet (Pass. Side); Exc 3500HD  
 GMC; Suburban; 1997; V-8 6.5 Diesel Eng.; Outlet (Pass. Side); W/1/2" Tubing  
 GMC; Suburban; 1996-1995; V-8 6.5 Diesel Eng.; Outlet (Pass. Side)  
 GMC; Yukon; 1997; V-8 6.5 Diesel Eng.; Outlet (Pass. Side); W/1/2" Tubing  
 GMC; Yukon; 1996-1995; V-8 6.5 Diesel Eng.; Outlet (Pass. Side)

## B64216

Chev; Blazer Full Size; 1993-1992; V-8 5.7 Eng.; Inlet (Lower); W/2WD  
 Chev; C&K Pickup; 1993-1992; V-8 5.7 Eng.; Inlet (Lower); W/O Aux. Cooler; W/2WD  
 Chev; C&K Pickup; 1991; V-8 5.7 Eng.; Inlet (Upper); W/O Aux. Cooler; W/2WD; HD  
 Chev; Suburban; 1993-1992; V-8 5.7 Eng.; Inlet (Lower); W/O Aux. Cooler; W/2WD  
 GMC; C&K Pickup; 1993-1992; V-8 5.7 Eng.; Inlet (Lower); W/O Aux. Cooler; W/2WD  
 GMC; C&K Pickup; 1991; V-8 5.7 Eng.; Inlet (Upper); W/O Aux. Cooler; W/2WD; HD  
 GMC; Suburban; 1993-1992; V-8 5.7 Eng.; Inlet (Lower); W/O Aux. Cooler; W/2WD  
 GMC; Yukon; 1993-1992; V-8 5.7 Eng.; Inlet (Lower); W/O Aux. Cooler

## B64217

Chev; C&K Pickup; 1995-1989; V-8 5.0 Eng.; Inlet (Lower); W/2WD  
 Chev; C&K Pickup; 1988; V-8 5.0 Eng.; Inlet (Lower); W/2WD; Late  
 Chev; C&K Pickup; 1994; V-8 5.7 Eng.; Inlet (Lower); W/2WD; Exc Chassis Cab  
 Chev; C&K Pickup; 1991; V-8 5.7 Eng.; Inlet (Lower); W/O Aux. Cooler; W/2WD; Exc HD  
 Chev; C&K Pickup; 1990-1988; V-8 5.7 Eng.; Inlet (Lower); W/O Aux. Cooler; W/2WD  
 GMC; C&K Pickup; 1995-1989; V-8 5.0 Eng.; Inlet (Lower); W/2WD  
 GMC; C&K Pickup; 1988; V-8 5.0 Eng.; Inlet (Lower); W/2WD; Late  
 GMC; C&K Pickup; 1994; V-8 5.7 Eng.; Inlet (Lower); W/2WD; Exc Chassis Cab  
 GMC; C&K Pickup; 1991; V-8 5.7 Eng.; Inlet (Lower); W/O Aux. Cooler; W/2WD; Exc HD  
 GMC; C&K Pickup; 1990-1988; V-8 5.7 Eng.; Inlet (Lower); W/O Aux. Cooler; W/2WD

## B64218

Chev; C&K Pickup; 1995-1989; V-8 5.0 Eng.; Inlet (Upper); W/4WD  
 Chev; C&K Pickup; 1988; V-8 5.0 Eng.; Inlet (Upper); W/4WD; Late  
 Chev; C&K Pickup; 1994; V-8 5.7 Eng.; Inlet (Upper); W/4WD; Exc Chassis Cab  
 Chev; C&K Pickup; 1991; V-8 5.7 Eng.; Inlet (Upper); W/O Aux. Cooler; W/4WD; Exc HD  
 Chev; C&K Pickup; 1990-1988; V-8 5.7 Eng.; Inlet (Upper); W/O Aux. Cooler; W/4WD  
 GMC; C&K Pickup; 1995-1989; V-8 5.0 Eng.; Inlet (Upper); W/4WD  
 GMC; C&K Pickup; 1988; V-8 5.0 Eng.; Inlet (Upper); W/4WD; Late  
 GMC; C&K Pickup; 1994; V-8 5.7 Eng.; Inlet (Upper); W/4WD; Exc Chassis Cab  
 GMC; C&K Pickup; 1991; V-8 5.7 Eng.; Inlet (Upper); W/O Aux. Cooler; W/4WD; Exc HD

## B64218 - Continued

GMC; C&K Pickup; 1990-1988; V-8 5.7 Eng.; Inlet (Upper); W/O Aux. Cooler; W/4WD

## B64219

Chev; Blazer Compact; 1994-1988; V-6 4.3 Eng.; Inlet & Outlet Assy To Remote Oil Filter; W/4WD  
 Chev; S Pickup; 1993-1988; V-6 4.3 Eng.; Inlet & Outlet Assy To Remote Oil Filter; W/4WD  
 GMC; Jimmy; 1994-1992; V-6 4.3 Eng.; Inlet & Outlet Assy To Remote Oil Filter; W/4WD  
 GMC; Jimmy Compact; 1991-1988; V-6 4.3 Eng.; Inlet & Outlet Assy To Remote Oil Filter; W/4WD  
 GMC; S Pickup; 1990-1988; V-6 4.3 Eng.; Inlet & Outlet Assy To Remote Oil Filter; W/4WD  
 GMC; Sonoma; 1993-1991; V-6 4.3 Eng.; Inlet & Outlet Assy To Remote Oil Filter; W/4WD  
 GMC; Syclone; 1992-1991; V-6 4.3 Eng.; Inlet & Outlet Assy To Remote Oil Filter; W/4WD  
 GMC; Typhoon; 1993-1992; V-6 4.3 Eng.; Inlet & Outlet Assy To Remote Oil Filter; W/4WD  
 Olds; Bravada; 1994-1991; V-6 4.3 Eng.; Inlet & Outlet Assy To Remote Oil Filter; W/4WD

## B64220

Chev; Blazer; 2005-1996; V-6 4.3 Eng.; Inlet & Outlet Assy To Eng Block Adapter; W/4WD  
 Chev; S Pickup; 2004-1996; V-6 4.3 Eng.; Inlet & Outlet Assy To Eng Block Adapter; W/4WD  
 GMC; Jimmy; 2001-1996; V-6 4.3 Eng.; Inlet & Outlet Assy To Eng Block Adapter; W/4WD  
 GMC; Jimmy; 2004-2002; V-6 4.3 (Canada) Eng.; Inlet & Outlet Assy To Eng Block Adapter; W/4WD  
 GMC; Sonoma; 2004-1996; V-6 4.3 Eng.; Inlet & Outlet Assy To Eng Block Adapter; W/4WD  
 Olds; Bravada; 2001-1996; V-6 4.3 Eng.; Inlet & Outlet Assy To Eng Block Adapter; W/4WD

## B64221

Chev; Blazer; 1995; V-6 4.3 Eng.; Inlet & Outlet Assy To Eng Block Adapter; W/4WD  
 Chev; S Pickup; 1995-1994; V-6 4.3 Eng.; Inlet & Outlet Assy To Eng Block Adapter; W/4WD  
 GMC; Jimmy; 1995; V-6 4.3 Eng.; Inlet & Outlet Assy To Eng Block Adapter; W/4WD  
 GMC; Sonoma; 1995-1994; V-6 4.3 Eng.; Inlet & Outlet Assy To Eng Block Adapter; W/4WD

## B64222

Chev; Astro; 2005-1996; V-6 4.3 Eng.; Inlet & Outlet Assy  
 GMC; Safari; 2005-1996; V-6 4.3 Eng.; Inlet & Outlet Assy

## B64223

Chev; Blazer; 1995; V-6 4.3 Eng.; Inlet & Outlet Assy From Oil Filter to Rad; W/4WD  
 Chev; S Pickup; 1995-1994; V-6 4.3 Eng.; Inlet & Outlet Assy From Oil Filter to Rad; W/4WD  
 GMC; Jimmy; 1995; V-6 4.3 Eng.; Inlet & Outlet Assy From Oil Filter to Rad; W/4WD  
 GMC; Sonoma; 1995-1994; V-6 4.3 Eng.; Inlet & Outlet Assy From Oil Filter to Rad; W/4WD

## B64224

Chev; Blazer; 2005-1996; V-6 4.3 Eng.; Inlet & Outlet Assy; W/2WD  
 Chev; S Pickup; 2004-1996; V-6 4.3 Eng.; Inlet & Outlet Assy; W/2WD  
 GMC; Jimmy; 2001-1996; V-6 4.3 Eng.; Inlet & Outlet Assy; W/2WD  
 GMC; Jimmy; 2004-2002; V-6 4.3 (Canada) Eng.; Inlet & Outlet Assy; W/2WD  
 GMC; Sonoma; 2004-1996; V-6 4.3 Eng.; Inlet & Outlet Assy; W/2WD  
 Olds; Bravada; 2001-1996; V-6 4.3 Eng.; Inlet & Outlet Assy; W/2WD

## B64225

Chev; Blazer; 2005-1996; V-6 4.3 Eng.; Inlet & Outlet Assy From Oil Filter to Rad; W/4WD  
 Chev; S Pickup; 2004-1996; V-6 4.3 Eng.; Inlet & Outlet Assy From Oil Filter to Rad; W/4WD  
 GMC; Jimmy; 2001-1996; V-6 4.3 Eng.; Inlet & Outlet Assy From Oil Filter to Rad; W/4WD

# Numerical Listing - Oil Cooler Assemblies & End Fittings

Product Section

Troubleshooting

EOC Applications

TOC Applications

Numerical Listing

Manufacturers' Part Numbers

End Fittings

Illustrations

## B64225 - Continued

GMC; Jimmy; 2004-2002; V-6 4.3 (Canada) Eng.; Inlet & Outlet Assy From Oil Filter to Rad; W/4WD  
 GMC; Sonoma; 2004-1996; V-6 4.3 Eng.; Inlet & Outlet Assy From Oil Filter to Rad; W/4WD  
 Olds; Bravada; 2001-1996; V-6 4.3 Eng.; Inlet & Outlet Assy From Oil Filter to Rad; W/4WD

## B64226

Chev; Blazer Full Size; 1993-1992; V-8 5.7 Eng.; Outlet (Upper); W/2WD  
 Chev; C&K Pickup; 1993-1992; V-8 5.7 Eng.; Outlet (Upper); W/O Aux. Cooler; W/2WD  
 Chev; C&K Pickup; 1991; V-8 5.7 Eng.; Outlet (Lower); W/O Aux. Cooler; W/2WD; HD  
 Chev; Suburban; 1993-1992; V-8 5.7 Eng.; Outlet (Upper); W/O Aux. Cooler; W/2WD  
 GMC; C&K Pickup; 1993-1992; V-8 5.7 Eng.; Outlet (Upper); W/O Aux. Cooler; W/2WD  
 GMC; C&K Pickup; 1991; V-8 5.7 Eng.; Outlet (Lower); W/O Aux. Cooler; W/2WD; HD  
 GMC; Suburban; 1993-1992; V-8 5.7 Eng.; Outlet (Upper); W/O Aux. Cooler; W/2WD  
 GMC; Yukon; 1993-1992; V-8 5.7 Eng.; Outlet (Upper); W/O Aux. Cooler

## B64227

Chev; C&K Pickup; 1995-1989; V-8 5.0 Eng.; Outlet (Upper); W/2WD  
 Chev; C&K Pickup; 1988; V-8 5.0 Eng.; Outlet (Upper); W/2WD; Late  
 Chev; C&K Pickup; 1994; V-8 5.7 Eng.; Outlet (Upper); W/2WD; Exc Chassis Cab  
 Chev; C&K Pickup; 1991; V-8 5.7 Eng.; Outlet (Upper); W/O Aux. Cooler; W/2WD; Exc HD  
 Chev; C&K Pickup; 1990-1988; V-8 5.7 Eng.; Outlet (Upper); W/O Aux. Cooler; W/2WD  
 GMC; C&K Pickup; 1995-1989; V-8 5.0 Eng.; Outlet (Upper); W/2WD  
 GMC; C&K Pickup; 1988; V-8 5.0 Eng.; Outlet (Upper); W/2WD; Late  
 GMC; C&K Pickup; 1994; V-8 5.7 Eng.; Outlet (Upper); W/2WD; Exc Chassis Cab  
 GMC; C&K Pickup; 1991; V-8 5.7 Eng.; Outlet (Upper); W/O Aux. Cooler; W/2WD; Exc HD  
 GMC; C&K Pickup; 1990-1988; V-8 5.7 Eng.; Outlet (Upper); W/O Aux. Cooler; W/2WD

## B64228

Chev; C&K Pickup; 1995-1989; V-8 5.0 Eng.; Outlet (Lower); W/4WD  
 Chev; C&K Pickup; 1988; V-8 5.0 Eng.; Outlet (Lower); W/4WD; Late  
 Chev; C&K Pickup; 1994; V-8 5.7 Eng.; Outlet (Lower); W/4WD; Exc Chassis Cab  
 Chev; C&K Pickup; 1991; V-8 5.7 Eng.; Outlet (Lower); W/O Aux. Cooler; W/4WD; Exc HD  
 Chev; C&K Pickup; 1990-1988; V-8 5.7 Eng.; Outlet (Lower); W/O Aux. Cooler; W/4WD  
 GMC; C&K Pickup; 1995-1989; V-8 5.0 Eng.; Outlet (Lower); W/4WD  
 GMC; C&K Pickup; 1988; V-8 5.0 Eng.; Outlet (Lower); W/4WD; Late  
 GMC; C&K Pickup; 1994; V-8 5.7 Eng.; Outlet (Lower); W/4WD; Exc Chassis Cab  
 GMC; C&K Pickup; 1991; V-8 5.7 Eng.; Outlet (Lower); W/O Aux. Cooler; W/4WD; Exc HD  
 GMC; C&K Pickup; 1990-1988; V-8 5.7 Eng.; Outlet (Lower); W/O Aux. Cooler; W/4WD

## B64229

Cad; Escalade; 2000-1999; V-8 5.7 Eng.; Outlet (Upper); W/2WD  
 Chev; C&K Pickup; 1999-1996; V-8 5.0 Eng.; Inlet (Lower); W/140A Alt; W/2WD  
 Chev; C&K Pickup; 2000-1996; V-8 5.7 Eng.; Inlet (Lower); W/2WD  
 Chev; Suburban; 1999-1996; V-8 5.7 Eng.; Inlet (Lower); W/2WD  
 Chev; Tahoe; 2000-1996; V-8 5.7 Eng.; Inlet (Lower); W/2WD  
 GMC; C&K Pickup; 1999-1996; V-8 5.0 Eng.; Inlet (Lower); W/140A Alt; W/2WD  
 GMC; C&K Pickup; 2000-1996; V-8 5.7 Eng.; Inlet (Lower); W/2WD  
 GMC; Suburban; 1999-1996; V-8 5.7 Eng.; Inlet (Lower); W/2WD  
 GMC; Yukon; 2000-1996; V-8 5.7 Eng.; Inlet (Lower); W/2WD

## B64230

Cad; Escalade; 2000-1999; V-8 5.7 Eng.; Inlet (Lower); W/2WD  
 Chev; C&K Pickup; 1999-1996; V-8 5.0 Eng.; Outlet (Upper); W/140A Alt; W/2WD  
 Chev; C&K Pickup; 2000-1996; V-8 5.7 Eng.; Outlet (Upper); W/2WD  
 Chev; Suburban; 1999-1996; V-8 5.7 Eng.; Outlet (Upper); W/2WD  
 Chev; Tahoe; 2000-1996; V-8 5.7 Eng.; Outlet (Upper); W/2WD

## B64230 - Continued

GMC; C&K Pickup; 1999-1996; V-8 5.0 Eng.; Outlet (Upper); W/140A Alt; W/2WD  
 GMC; C&K Pickup; 2000-1996; V-8 5.7 Eng.; Outlet (Upper); W/2WD  
 GMC; Suburban; 1999-1996; V-8 5.7 Eng.; Outlet (Upper); W/2WD  
 GMC; Yukon; 2000-1996; V-8 5.7 Eng.; Outlet (Upper); W/2WD

## B64231

Chev; C&K Pickup; 2000-1996; V-8 7.4 Eng.; Inlet (Lower)  
 Chev; Suburban; 1999-1996; V-8 7.4 Eng.; Inlet (Lower)  
 GMC; C&K Pickup; 2000-1996; V-8 7.4 Eng.; Inlet (Lower)  
 GMC; Suburban; 1999-1996; V-8 7.4 Eng.; Inlet (Lower)

## B64232

Chev; C&K Pickup; 2000-1996; V-8 7.4 Eng.; Outlet (Upper); Exc 3500HD  
 Chev; Suburban; 1999-1996; V-8 7.4 Eng.; Outlet (Upper)  
 GMC; C&K Pickup; 2000-1996; V-8 7.4 Eng.; Outlet (Upper); Exc 3500HD  
 GMC; Suburban; 1999-1996; V-8 7.4 Eng.; Outlet (Upper)

## B64233

Chev; Express; 2002-1996; V-8 5.0 Eng.; Inlet (Upper)  
 Chev; Express; 2002-1996; V-8 5.7 Eng.; Inlet (Upper)  
 Chev; G Van; 1998-1997; V-8 5.0 Eng.; Inlet (Upper)  
 Chev; G Van; 1998-1997; V-8 5.7 Eng.; Inlet (Upper)  
 GMC; Savana; 2002-1996; V-8 5.0 Eng.; Inlet (Upper)  
 GMC; Savana; 2002-1996; V-8 5.7 Eng.; Inlet (Upper)

## B64234

Chev; Express; 2002-1996; V-8 5.0 Eng.; Outlet (Lower)  
 Chev; Express; 2002-1996; V-8 5.7 Eng.; Outlet (Lower)  
 Chev; G Van; 1998-1997; V-8 5.0 Eng.; Outlet (Lower)  
 Chev; G Van; 1998-1997; V-8 5.7 Eng.; Outlet (Lower)  
 GMC; Savana; 2002-1996; V-8 5.0 Eng.; Outlet (Lower)  
 GMC; Savana; 2002-1996; V-8 5.7 Eng.; Outlet (Lower)

## B64235

Chev; G Van; 1993-1992; V-6 4.3 Eng.; Inlet (Upper); W/O Front AC  
 Chev; G Van; 1991-1985; V-6 4.3 Eng.; Inlet (Lower)  
 GMC; G Van; 1993-1992; V-6 4.3 Eng.; Inlet (Upper); W/O Front AC  
 GMC; G Van; 1991-1985; V-6 4.3 Eng.; Inlet (Lower)

## B64236

Chev; G Van; 1993-1992; V-6 4.3 Eng.; Outlet (Upper); W/O Front AC  
 Chev; G Van; 1991-1985; V-6 4.3 Eng.; Outlet (Upper)  
 GMC; G Van; 1993-1992; V-6 4.3 Eng.; Outlet (Upper); W/O Front AC  
 GMC; G Van; 1991-1985; V-6 4.3 Eng.; Outlet (Upper)

## B64237

Chev; G Van; 1996-1994; V-6 4.3 Eng.; Inlet (Lower)  
 Chev; G Van; 1993-1992; V-6 4.3 Eng.; Inlet (Lower); W/Front AC  
 GMC; G Van; 1996-1994; V-6 4.3 Eng.; Inlet (Lower)  
 GMC; G Van; 1993-1992; V-6 4.3 Eng.; Inlet (Lower); W/Front AC

## B64238

Chev; G Van; 1996-1994; V-6 4.3 Eng.; Outlet (Upper)  
 Chev; G Van; 1993-1992; V-6 4.3 Eng.; Outlet (Upper); W/Front AC  
 GMC; G Van; 1996-1994; V-6 4.3 Eng.; Outlet (Upper)  
 GMC; G Van; 1993-1992; V-6 4.3 Eng.; Outlet (Upper); W/Front AC

## B64239

Chev; Astro; 1995; V-6 4.3 Eng.; Outlet (Lower)  
 GMC; Safari; 1995; V-6 4.3 Eng.; Outlet (Lower)

## B64240

Chev; Astro; 1995; V-6 4.3 Eng.; Inlet (Upper)  
 GMC; Safari; 1995; V-6 4.3 Eng.; Inlet (Upper)

## B64241

Chev; Astro; 1994; V-6 4.3 Eng.; Inlet (Upper); W/2WD  
 GMC; Safari; 1994; V-6 4.3 Eng.; Inlet (Upper); W/2WD

## B64242

Chev; Astro; 1994; V-6 4.3 Eng.; Outlet (Lower); W/2WD

# Numerical Listing - Oil Cooler Assemblies & End Fittings

## B64242 - Continued

GMC; Safari; 1994; V-6 4.3 Eng.; Outlet (Lower); W/2WD

### B64243

Chev; Blazer Full Size; 1991-1988; V-8 5.7 Eng.; Aux. Cooler Inlet (Pass. Side)  
 Chev; R&V Pickup; 1991-1988; V-8 5.7 Eng.; Aux. Cooler Inlet (Pass. Side); W/4WD  
 Chev; R&V Pickup; 1991-1988; V-8 7.4 Eng.; Aux. Cooler Inlet (Pass. Side); W/4WD  
 Chev; Suburban; 1991-1988; V-8 5.7 Eng.; Aux. Cooler Inlet (Pass. Side); W/4WD  
 Chev; Suburban; 1991-1988; V-8 7.4 Eng.; Aux. Cooler Inlet (Pass. Side); W/4WD  
 GMC; Jimmy Full Size; 1991-1988; V-8 5.7 Eng.; Aux. Cooler Inlet (Pass. Side)  
 GMC; R&V Pickup; 1991-1988; V-8 5.7 Eng.; Aux. Cooler Inlet (Pass. Side); W/4WD  
 GMC; R&V Pickup; 1991-1988; V-8 7.4 Eng.; Aux. Cooler Inlet (Pass. Side); W/4WD  
 GMC; Suburban; 1991-1988; V-8 5.7 Eng.; Aux. Cooler Inlet (Pass. Side); W/4WD  
 GMC; Suburban; 1991-1988; V-8 7.4 Eng.; Aux. Cooler Inlet (Pass. Side); W/4WD

### B64244

Chev; Blazer Full Size; 1991-1988; V-8 5.7 Eng.; Aux. Cooler Outlet (Driver Side)  
 Chev; R&V Pickup; 1991-1988; V-8 5.7 Eng.; Aux. Cooler Outlet (Driver Side); W/4WD  
 Chev; R&V Pickup; 1991-1988; V-8 7.4 Eng.; Aux. Cooler Outlet (Driver Side); W/4WD  
 Chev; Suburban; 1991-1988; V-8 5.7 Eng.; Aux. Cooler Outlet (Driver Side); W/4WD  
 Chev; Suburban; 1991-1988; V-8 7.4 Eng.; Aux. Cooler Outlet (Driver Side); W/4WD  
 GMC; Jimmy Full Size; 1991-1988; V-8 5.7 Eng.; Aux. Cooler Outlet (Driver Side)  
 GMC; R&V Pickup; 1991-1988; V-8 5.7 Eng.; Aux. Cooler Outlet (Driver Side); W/4WD  
 GMC; R&V Pickup; 1991-1988; V-8 7.4 Eng.; Aux. Cooler Outlet (Driver Side); W/4WD  
 GMC; Suburban; 1991-1988; V-8 5.7 Eng.; Aux. Cooler Outlet (Driver Side); W/4WD  
 GMC; Suburban; 1991-1988; V-8 7.4 Eng.; Aux. Cooler Outlet (Driver Side); W/4WD

### B64245

Chev; C&K Pickup; 1995; V-8 5.7 Eng.; Inlet (Lower); W/2WD  
 Chev; C&K Pickup; 1994; V-8 5.7 Eng.; Inlet (Lower); W/2WD; W/Chassis Cab  
 Chev; Suburban; 1995-1994; V-8 5.7 Eng.; Inlet (Lower); W/2WD  
 Chev; Tahoe; 1995; V-8 5.7 Eng.; Inlet (Lower); W/2WD  
 GMC; C&K Pickup; 1995; V-8 5.7 Eng.; Inlet (Lower); W/2WD  
 GMC; C&K Pickup; 1994; V-8 5.7 Eng.; Inlet (Lower); W/2WD; W/Chassis Cab  
 GMC; Suburban; 1995-1994; V-8 5.7 Eng.; Inlet (Lower); W/2WD  
 GMC; Yukon; 1995-1994; V-8 5.7 Eng.; Inlet (Lower); W/2WD

### B64246

Chev; C&K Pickup; 1995; V-8 5.7 Eng.; Outlet (Upper); W/2WD  
 Chev; C&K Pickup; 1994; V-8 5.7 Eng.; Outlet (Upper); W/2WD; W/Chassis Cab  
 Chev; Suburban; 1995-1994; V-8 5.7 Eng.; Outlet (Upper); W/2WD  
 Chev; Tahoe; 1995; V-8 5.7 Eng.; Outlet (Upper); W/2WD  
 GMC; C&K Pickup; 1995; V-8 5.7 Eng.; Outlet (Upper); W/2WD  
 GMC; C&K Pickup; 1994; V-8 5.7 Eng.; Outlet (Upper); W/2WD; W/Chassis Cab  
 GMC; Suburban; 1995-1994; V-8 5.7 Eng.; Outlet (Upper); W/2WD  
 GMC; Yukon; 1995-1994; V-8 5.7 Eng.; Outlet (Upper); W/2WD

### B64247

Chev; Blazer Full Size; 1993-1992; V-8 5.7 Eng.; Inlet (Upper); W/4WD; W/O Aux. Cooler  
 Chev; C&K Pickup; 1993-1992; V-8 5.7 Eng.; Inlet (Upper); W/O Aux. Cooler; W/4WD  
 Chev; C&K Pickup; 1991; V-8 5.7 Eng.; Inlet (Upper); W/O Aux. Cooler; W/4WD; HD  
 Chev; Suburban; 1993-1992; V-8 5.7 Eng.; Inlet (Upper); W/O Aux. Cooler; W/4WD

## B64247 - Continued

GMC; C&K Pickup; 1993-1992; V-8 5.7 Eng.; Inlet (Upper); W/O Aux. Cooler; W/4WD  
 GMC; C&K Pickup; 1991; V-8 5.7 Eng.; Inlet (Upper); W/O Aux. Cooler; W/4WD; HD  
 GMC; Suburban; 1993-1992; V-8 5.7 Eng.; Inlet (Upper); W/O Aux. Cooler; W/4WD

### B64248

Chev; Blazer Full Size; 1993-1992; V-8 5.7 Eng.; Outlet (Lower); W/4WD; W/O Aux. Cooler  
 Chev; C&K Pickup; 1993-1992; V-8 5.7 Eng.; Outlet (Lower); W/O Aux. Cooler; W/4WD  
 Chev; C&K Pickup; 1991; V-8 5.7 Eng.; Outlet (Lower); W/O Aux. Cooler; W/4WD; HD  
 Chev; Suburban; 1993-1992; V-8 5.7 Eng.; Outlet (Lower); W/O Aux. Cooler; W/4WD  
 GMC; C&K Pickup; 1993-1992; V-8 5.7 Eng.; Outlet (Lower); W/O Aux. Cooler; W/4WD  
 GMC; C&K Pickup; 1991; V-8 5.7 Eng.; Outlet (Lower); W/O Aux. Cooler; W/4WD; HD  
 GMC; Suburban; 1993-1992; V-8 5.7 Eng.; Outlet (Lower); W/O Aux. Cooler; W/4WD

### B64249

Chev; C&K Pickup; 1998-1996; V-6 4.3 Eng.; Inlet (Upper)  
 GMC; C&K Pickup; 1998-1996; V-6 4.3 Eng.; Inlet (Upper)

### B64250

Chev; C&K Pickup; 1998-1996; V-6 4.3 Eng.; Outlet (Lower)  
 GMC; C&K Pickup; 1998-1996; V-6 4.3 Eng.; Outlet (Lower)

### B64251

Chev; C&K Pickup; 1991-1989; V-8 6.2 Diesel Eng.; Aux. Cooler Inlet (Driver Side)  
 Chev; C&K Pickup; 1988; V-8 6.2 Diesel Eng.; Aux. Cooler Inlet (Driver Side); W/2WD  
 Chev; C&K Pickup; 1988; V-8 6.2 Diesel Eng.; Aux. Cooler Inlet (Driver Side); W/4WD; 2nd Design  
 GMC; C&K Pickup; 1991-1989; V-8 6.2 Diesel Eng.; Aux. Cooler Inlet (Driver Side)  
 GMC; C&K Pickup; 1988; V-8 6.2 Diesel Eng.; Aux. Cooler Inlet (Driver Side); W/2WD  
 GMC; C&K Pickup; 1988; V-8 6.2 Diesel Eng.; Aux. Cooler Inlet (Driver Side); W/4WD; 2nd Design

### B64252

Chev; Blazer Full Size; 1994; V-8 6.5 Diesel Eng.; Aux. Cooler Outlet (Driver Side)  
 Chev; C&K Pickup; 1993-1989; V-8 6.2 Diesel Eng.; Aux. Cooler Outlet (Pass. Side)  
 Chev; C&K Pickup; 1988; V-8 6.2 Diesel Eng.; Aux. Cooler Outlet (Pass. Side); W/2WD  
 Chev; C&K Pickup; 1988; V-8 6.2 Diesel Eng.; Aux. Cooler Outlet (Pass. Side); W/4WD; 2nd Design  
 Chev; C&K Pickup; 1994; V-8 6.5 Diesel Eng.; Aux. Cooler Outlet (Driver Side); Exc 3500HD  
 Chev; C&K Pickup; 1993-1992; V-8 6.5 Diesel Eng.; Aux. Cooler Outlet (Pass. Side)  
 GMC; C&K Pickup; 1993-1989; V-8 6.2 Diesel Eng.; Aux. Cooler Outlet (Pass. Side)  
 GMC; C&K Pickup; 1988; V-8 6.2 Diesel Eng.; Aux. Cooler Outlet (Pass. Side); W/2WD  
 GMC; C&K Pickup; 1988; V-8 6.2 Diesel Eng.; Aux. Cooler Outlet (Pass. Side); W/4WD; 2nd Design  
 GMC; C&K Pickup; 1994; V-8 6.5 Diesel Eng.; Aux. Cooler Outlet (Driver Side); Exc 3500HD  
 GMC; C&K Pickup; 1993-1992; V-8 6.5 Diesel Eng.; Aux. Cooler Outlet (Pass. Side)

### B64253

Chev; Blazer Full Size; 1994; V-8 6.5 Diesel Eng.; Aux. Cooler Inlet (Pass. Side)  
 Chev; C&K Pickup; 1993-1992; V-8 6.2 Diesel Eng.; Aux. Cooler Inlet (Driver Side)  
 Chev; C&K Pickup; 1994; V-8 6.5 Diesel Eng.; Aux. Cooler Inlet (Pass. Side); Exc 3500HD  
 Chev; C&K Pickup; 1993-1992; V-8 6.5 Diesel Eng.; Aux. Cooler Inlet (Driver Side)

# Numerical Listing - Oil Cooler Assemblies & End Fittings

Product Section

Troubleshooting

EOC Applications

TOC Applications

Numerical Listing

Manufacturers' Part Numbers

End Fittings

Illustrations

## B64253 - Continued

GMC; C&K Pickup; 1993-1992; V-8 6.2 Diesel Eng.; Aux. Cooler Inlet (Driver Side)  
 GMC; C&K Pickup; 1994; V-8 6.5 Diesel Eng.; Aux. Cooler Inlet (Pass. Side); Exc 3500HD  
 GMC; C&K Pickup; 1993-1992; V-8 6.5 Diesel Eng.; Aux. Cooler Inlet (Driver Side)

## B64254

Chev; C&K Pickup; 1993-1988; V-8 6.2 Diesel Eng.; Inlet (Upper); W/O Aux. Cooler  
 Chev; C&K Pickup; 1993-1992; V-8 6.5 Diesel Eng.; Inlet (Upper); W/O Aux. Cooler  
 GMC; C&K Pickup; 1993-1988; V-8 6.2 Diesel Eng.; Inlet (Upper); W/O Aux. Cooler  
 GMC; C&K Pickup; 1993-1992; V-8 6.5 Diesel Eng.; Inlet (Upper); W/O Aux. Cooler

## B64255

Chev; C&K Pickup; 1993-1988; V-8 6.2 Diesel Eng.; Outlet (Lower); W/O Aux. Cooler  
 Chev; C&K Pickup; 1993-1992; V-8 6.5 Diesel Eng.; Outlet (Lower); W/O Aux. Cooler  
 GMC; C&K Pickup; 1993-1988; V-8 6.2 Diesel Eng.; Outlet (Lower); W/O Aux. Cooler  
 GMC; C&K Pickup; 1993-1992; V-8 6.5 Diesel Eng.; Outlet (Lower); W/O Aux. Cooler

## B64256

Chev; C&K Pickup; 1993-1992; V-8 7.4 Eng.; Inlet (Lower); W/O Aux. Cooler; Exc HD  
 Chev; Suburban; 1993-1992; V-8 7.4 Eng.; Inlet (Lower); W/O Aux. Cooler  
 GMC; C&K Pickup; 1993-1992; V-8 7.4 Eng.; Inlet (Lower); W/O Aux. Cooler; Exc HD  
 GMC; Suburban; 1993-1992; V-8 7.4 Eng.; Inlet (Lower); W/O Aux. Cooler

## B64257

Chev; C&K Pickup; 1993-1992; V-8 7.4 Eng.; Outlet (Upper); W/O Aux. Cooler; Exc HD  
 Chev; Suburban; 1993-1992; V-8 7.4 Eng.; Outlet (Upper); W/O Aux. Cooler  
 GMC; C&K Pickup; 1993-1992; V-8 7.4 Eng.; Outlet (Upper); W/O Aux. Cooler; Exc HD  
 GMC; Suburban; 1993-1992; V-8 7.4 Eng.; Outlet (Upper); W/O Aux. Cooler

## B64258

Chev; C&K Pickup; 1997; V-8 6.5 Diesel Eng.; Inlet (Driver Side); W/1/2" Tubing; 3500HD  
 Chev; C&K Pickup; 1996-1995; V-8 6.5 Diesel Eng.; Inlet (Driver Side); 3500HD  
 GMC; C&K Pickup; 1997; V-8 6.5 Diesel Eng.; Inlet (Driver Side); W/1/2" Tubing; 3500HD  
 GMC; C&K Pickup; 1996-1995; V-8 6.5 Diesel Eng.; Inlet (Driver Side); 3500HD

## B64259

Chev; C&K Pickup; 1997; V-8 6.5 Diesel Eng.; Outlet (Pass. Side); W/1/2" Tubing; 3500HD  
 Chev; C&K Pickup; 1996-1995; V-8 6.5 Diesel Eng.; Outlet (Pass. Side); 3500HD  
 GMC; C&K Pickup; 1997; V-8 6.5 Diesel Eng.; Outlet (Pass. Side); W/1/2" Tubing; 3500HD  
 GMC; C&K Pickup; 1996-1995; V-8 6.5 Diesel Eng.; Outlet (Pass. Side); 3500HD

## B64260

Chev; Blazer Compact; 1994-1992; V-6 4.3 Eng.; Inlet & Outlet Assy From Oil Filter to Rad; W/4WD; VIN Z  
 Chev; Blazer Compact; 1989-1988; V-6 4.3 Eng.; Inlet & Outlet Assy From Oil Filter to Rad; W/4WD  
 Chev; S Pickup; 1993-1992; V-6 4.3 Eng.; Inlet & Outlet Assy From Oil Filter to Rad; W/4WD; VIN Z  
 Chev; S Pickup; 1989-1988; V-6 4.3 Eng.; Inlet & Outlet Assy From Oil Filter to Rad; W/4WD  
 GMC; Jimmy; 1994-1992; V-6 4.3 Eng.; Inlet & Outlet Assy From Oil Filter to Rad; W/4WD; VIN Z  
 GMC; Jimmy Compact; 1989-1988; V-6 4.3 Eng.; Inlet & Outlet Assy From Oil Filter to Rad; W/4WD

## B64260 - Continued

GMC; S Pickup; 1989-1988; V-6 4.3 Eng.; Inlet & Outlet Assy From Oil Filter to Rad; W/4WD  
 GMC; Sonoma; 1993-1992; V-6 4.3 Eng.; Inlet & Outlet Assy From Oil Filter to Rad; W/4WD; VIN Z  
 GMC; Syclone; 1992; V-6 4.3 Eng.; Inlet & Outlet Assy From Oil Filter to Rad; W/4WD; VIN Z  
 GMC; Typhoon; 1993-1992; V-6 4.3 Eng.; Inlet & Outlet Assy From Oil Filter to Rad; W/4WD  
 Olds; Bravada; 1992; V-6 4.3 Eng.; Inlet & Outlet Assy From Oil Filter to Rad; W/4WD; VIN Z  
 Olds; Bravada; 1991; V-6 4.3 Eng.; Inlet & Outlet Assy From Oil Filter to Rad; W/4WD

## B64261

Chev; Blazer Compact; 1994-1992; V-6 4.3 Eng.; Inlet & Outlet Assy From Oil Filter to Rad; W/4WD; VIN W  
 Chev; Blazer Compact; 1991-1990; V-6 4.3 Eng.; Inlet & Outlet Assy From Oil Filter to Rad; W/4WD  
 Chev; S Pickup; 1993-1992; V-6 4.3 Eng.; Inlet & Outlet Assy From Oil Filter to Rad; W/4WD; VIN W  
 Chev; S Pickup; 1991-1990; V-6 4.3 Eng.; Inlet & Outlet Assy From Oil Filter to Rad; W/4WD  
 GMC; Jimmy; 1994-1992; V-6 4.3 Eng.; Inlet & Outlet Assy From Oil Filter to Rad; W/4WD; VIN W  
 GMC; Jimmy Compact; 1991-1990; V-6 4.3 Eng.; Inlet & Outlet Assy From Oil Filter to Rad; W/4WD  
 GMC; S Pickup; 1990; V-6 4.3 Eng.; Inlet & Outlet Assy From Oil Filter to Rad; W/4WD  
 GMC; Sonoma; 1993-1992; V-6 4.3 Eng.; Inlet & Outlet Assy From Oil Filter to Rad; W/4WD; VIN W  
 GMC; Sonoma; 1991; V-6 4.3 Eng.; Inlet & Outlet Assy From Oil Filter to Rad; W/4WD  
 GMC; Syclone; 1992; V-6 4.3 Eng.; Inlet & Outlet Assy From Oil Filter to Rad; W/4WD; VIN W  
 GMC; Syclone; 1991; V-6 4.3 Eng.; Inlet & Outlet Assy From Oil Filter to Rad; W/4WD  
 Olds; Bravada; 1994-1993; V-6 4.3 Eng.; Inlet & Outlet Assy From Oil Filter to Rad; W/4WD  
 Olds; Bravada; 1992; V-6 4.3 Eng.; Inlet & Outlet Assy From Oil Filter to Rad; W/4WD; VIN W

## B64262

Chev; Express; 2002-1996; V-6 4.3 Eng.; Inlet & Outlet Assy  
 Chev; G Van; 1998-1997; V-6 4.3 Eng.; Inlet & Outlet Assy  
 GMC; Savana; 2002-1996; V-6 4.3 Eng.; Inlet & Outlet Assy

## B64263

Chev; Blazer Compact; 1994-1988; V-6 4.3 Eng.; Inlet (Lower); W/2WD  
 Chev; S Pickup; 1993-1988; V-6 4.3 Eng.; Inlet (Lower); W/2WD  
 GMC; Jimmy; 1994-1992; V-6 4.3 Eng.; Inlet (Lower); W/2WD  
 GMC; Jimmy Compact; 1991-1988; V-6 4.3 Eng.; Inlet (Lower); W/2WD  
 GMC; S Pickup; 1990-1988; V-6 4.3 Eng.; Inlet (Lower); W/2WD  
 GMC; Sonoma; 1993-1991; V-6 4.3 Eng.; Inlet (Lower); W/2WD  
 GMC; Syclone; 1992-1991; V-6 4.3 Eng.; Inlet (Lower); W/2WD  
 Olds; Bravada; 1994-1991; V-6 4.3 Eng.; Inlet (Lower); W/2WD

## B64264

Chev; Blazer Compact; 1994-1992; V-6 4.3 Eng.; Outlet (Upper); W/2WD; VIN Z  
 Chev; Blazer Compact; 1991-1988; V-6 4.3 Eng.; Outlet (Upper); W/2WD  
 Chev; S Pickup; 1993-1992; V-6 4.3 Eng.; Outlet (Upper); W/2WD; VIN Z  
 Chev; S Pickup; 1991-1988; V-6 4.3 Eng.; Outlet (Upper); W/2WD  
 GMC; Jimmy; 1994-1992; V-6 4.3 Eng.; Outlet (Upper); W/2WD; VIN Z  
 GMC; Jimmy Compact; 1991-1988; V-6 4.3 Eng.; Outlet (Upper); W/2WD  
 GMC; S Pickup; 1990-1988; V-6 4.3 Eng.; Outlet (Upper); W/2WD  
 GMC; Sonoma; 1993-1992; V-6 4.3 Eng.; Outlet (Upper); W/2WD; VIN Z  
 GMC; Sonoma; 1991; V-6 4.3 Eng.; Outlet (Upper); W/2WD  
 GMC; Syclone; 1992; V-6 4.3 Eng.; Outlet (Upper); W/2WD; VIN Z  
 GMC; Syclone; 1991; V-6 4.3 Eng.; Outlet (Upper); W/2WD  
 Olds; Bravada; 1992; V-6 4.3 Eng.; Outlet (Upper); W/2WD; VIN Z  
 Olds; Bravada; 1991; V-6 4.3 Eng.; Outlet (Upper); W/2WD

## B64265

Chev; R&V Pickup; 1991-1988; V-8 5.7 Eng.; Aux. Cooler Inlet (Pass. Side); W/2WD  
 Chev; R&V Pickup; 1991-1988; V-8 7.4 Eng.; Aux. Cooler Inlet (Pass. Side); W/2WD  
 Chev; Suburban; 1991-1988; V-8 5.7 Eng.; Aux. Cooler Inlet (Pass. Side); W/2WD



## Numerical Listing - Oil Cooler Assemblies & End Fittings

### B64265 - Continued

Chev; Suburban; 1991-1988; V-8 7.4 Eng.; Aux. Cooler Inlet (Pass. Side); W/2WD  
 GMC; R&V Pickup; 1991-1988; V-8 5.7 Eng.; Aux. Cooler Inlet (Pass. Side); W/2WD  
 GMC; R&V Pickup; 1991-1988; V-8 7.4 Eng.; Aux. Cooler Inlet (Pass. Side); W/2WD  
 GMC; Suburban; 1991-1988; V-8 5.7 Eng.; Aux. Cooler Inlet (Pass. Side); W/2WD  
 GMC; Suburban; 1991-1988; V-8 7.4 Eng.; Aux. Cooler Inlet (Pass. Side); W/2WD

### B64266

Chev; R&V Pickup; 1991-1988; V-8 5.7 Eng.; Aux. Cooler Outlet (Driver Side); W/2WD  
 Chev; R&V Pickup; 1991-1988; V-8 7.4 Eng.; Aux. Cooler Outlet (Driver Side); W/2WD  
 Chev; Suburban; 1991-1988; V-8 5.7 Eng.; Aux. Cooler Outlet (Driver Side); W/2WD  
 Chev; Suburban; 1991-1988; V-8 7.4 Eng.; Aux. Cooler Outlet (Driver Side); W/2WD  
 GMC; R&V Pickup; 1991-1988; V-8 5.7 Eng.; Aux. Cooler Outlet (Driver Side); W/2WD  
 GMC; R&V Pickup; 1991-1988; V-8 7.4 Eng.; Aux. Cooler Outlet (Driver Side); W/2WD  
 GMC; Suburban; 1991-1988; V-8 5.7 Eng.; Aux. Cooler Outlet (Driver Side); W/2WD  
 GMC; Suburban; 1991-1988; V-8 7.4 Eng.; Aux. Cooler Outlet (Driver Side); W/2WD

### B64267

Chev; C&K Pickup; 1993-1989; V-6 4.3 Eng.; Inlet (Upper)  
 Chev; C&K Pickup; 1988; V-6 4.3 Eng.; Inlet (Upper); Late  
 GMC; C&K Pickup; 1993-1989; V-6 4.3 Eng.; Inlet (Upper)  
 GMC; C&K Pickup; 1988; V-6 4.3 Eng.; Inlet (Upper); Late

### B64268

Chev; C&K Pickup; 1993-1989; V-6 4.3 Eng.; Outlet (Lower)  
 Chev; C&K Pickup; 1988; V-6 4.3 Eng.; Outlet (Lower); Late  
 GMC; C&K Pickup; 1993-1989; V-6 4.3 Eng.; Outlet (Lower)  
 GMC; C&K Pickup; 1988; V-6 4.3 Eng.; Outlet (Lower); Late

### B64269

Chev; Blazer Full Size; 1993-1992; V-8 5.7 Eng.; Aux. Cooler Inlet (Pass. Side); W/4WD  
 Chev; C&K Pickup; 1993-1988; V-8 5.7 Eng.; Aux. Cooler Inlet (Driver Side); W/4WD  
 Chev; Suburban; 1993-1992; V-8 5.7 Eng.; Aux. Cooler Outlet (Driver Side); W/4WD  
 GMC; C&K Pickup; 1993-1988; V-8 5.7 Eng.; Aux. Cooler Inlet (Driver Side); W/4WD  
 GMC; Suburban; 1993-1992; V-8 5.7 Eng.; Aux. Cooler Outlet (Driver Side); W/4WD

### B64270

Chev; Blazer Full Size; 1993-1992; V-8 5.7 Eng.; Aux. Cooler Outlet (Driver Side); W/4WD  
 Chev; C&K Pickup; 1993-1992; V-8 5.7 Eng.; Aux. Cooler Outlet (Pass. Side); W/4WD  
 Chev; Suburban; 1993-1992; V-8 5.7 Eng.; Aux. Cooler Inlet (Pass. Side); W/4WD  
 GMC; C&K Pickup; 1993-1992; V-8 5.7 Eng.; Aux. Cooler Outlet (Pass. Side); W/4WD  
 GMC; Suburban; 1993-1992; V-8 5.7 Eng.; Aux. Cooler Inlet (Pass. Side); W/4WD

### B64271

Chev; C&K Pickup; 1995-1994; V-6 4.3 Eng.; Inlet (Upper)  
 GMC; C&K Pickup; 1995-1994; V-6 4.3 Eng.; Inlet (Upper)

### B64272

Chev; C&K Pickup; 1995-1994; V-6 4.3 Eng.; Outlet (Lower)  
 GMC; C&K Pickup; 1995-1994; V-6 4.3 Eng.; Outlet (Lower)

### B64273

Chev; C&K Pickup; 1991-1988; V-8 5.7 Eng.; Aux. Cooler Outlet (Pass. Side); W/4WD

### B64273 - Continued

GMC; C&K Pickup; 1991-1988; V-8 5.7 Eng.; Aux. Cooler Outlet (Pass. Side); W/4WD

### B64274

Chev; C&K Pickup; 2000-1996; V-8 7.4 Eng.; Outlet (Upper); 3500HD  
 GMC; C&K Pickup; 2000-1996; V-8 7.4 Eng.; Outlet (Upper); 3500HD

### B64275

Chev; G Van; 1993-1992; V-8 6.2 Diesel Eng.; Inlet Hose (Lower) From Eng Block  
 GMC; G Van; 1993-1992; V-8 6.2 Diesel Eng.; Inlet Hose (Lower) From Eng Block

### B64276

Chev; G Van; 1993-1992; V-8 6.2 Diesel Eng.; Outlet Hose (Upper) From Eng Block  
 GMC; G Van; 1993-1992; V-8 6.2 Diesel Eng.; Outlet Hose (Upper) From Eng Block

### B64277

Chev; Blazer Full Size; 1991-1988; V-8 6.2 Diesel Eng.; Inlet Hose (Upper) From Eng Block  
 Chev; R&V Pickup; 1991-1988; V-8 6.2 Diesel Eng.; Inlet Hose (Upper) From Eng Block  
 Chev; Suburban; 1991-1988; V-8 6.2 Diesel Eng.; Inlet Hose (Upper) From Eng Block  
 GMC; Jimmy Full Size; 1991-1988; V-8 6.2 Diesel Eng.; Inlet Hose (Upper) From Eng Block  
 GMC; R&V Pickup; 1991-1988; V-8 6.2 Diesel Eng.; Inlet Hose (Upper) From Eng Block  
 GMC; Suburban; 1991-1988; V-8 6.2 Diesel Eng.; Inlet Hose (Upper) From Eng Block

### B64278

Chev; Blazer Full Size; 1991-1988; V-8 6.2 Diesel Eng.; Outlet Hose (Lower) From Eng Block  
 Chev; R&V Pickup; 1991-1988; V-8 6.2 Diesel Eng.; Outlet Hose (Lower) From Eng Block  
 Chev; Suburban; 1991-1988; V-8 6.2 Diesel Eng.; Outlet Hose (Lower) From Eng Block  
 GMC; Jimmy Full Size; 1991-1988; V-8 6.2 Diesel Eng.; Outlet Hose (Lower) From Eng Block  
 GMC; R&V Pickup; 1991-1988; V-8 6.2 Diesel Eng.; Outlet Hose (Lower) From Eng Block  
 GMC; Suburban; 1991-1988; V-8 6.2 Diesel Eng.; Outlet Hose (Lower) From Eng Block

# Manufacturers' Part Numbers Oil Cooler Assemblies

Factory Part Numbers for Engine & Transmission Oil Cooler Assemblies  
With Our Corresponding Replacement Numbers

Mfr. Part No.	Our No.	Mfr. Part No.	Our No.	Mfr. Part No.	Our No.
B7Q 2269 A.....	✧A63005	MB010582.....	✧A63000	10273349.....	B61054
D5AZ 7B093 A.....	✧A63000	MB033054.....	④A63109	10273666.....	A61031
E1DZ 7D273 A.....	A63049	MD707200.....	②A63097	10278606.....	B61297
E2TZ 7D273 A.....	②A63050	MD755023.....	✧A63001	10278608.....	B61296
E6VY 7D723 A.....	A63049	MF660064.....	④A63100	10278901.....	A61052
E9SZ 7A031 A.....	B61176	MR161255.....	✧A63000	10288031.....	A61298
F0DZ 7A030 B.....	✧A63000 (Hose) & ✧A63004 (Tube)	MR404206.....	✧A63000	10288032.....	A61299
F0DZ 7A030 D.....	B61177	N806239 S100.....	A63049	10290000.....	A61030
F0SZ 7A030 A.....	B61234	N809635 5089A.....	✧A63000	10409060.....	B61238
F0SZ7A030A.....	B61234	N809641 S400A.....	✧A63001	10415914.....	B61239
F1DZ 7C410 AA.....	B61178	XL3Z 7A030 AA.....	B61196	10416317.....	A61236
F5AZ 7H168 AF.....	B61180 (Inlet) & B61179 (Outlet)	XL3Z 7A031 AA.....	B61197	10430945.....	A61221
F5VZ 7H168 AF.....	B61182 (Inlet) & B61181 (Outlet)	XW7Z 7A031 AA.....	B61198	12339996.....	✧A63000
F6AZ 7A031 AA.....	B61185 (Inlet) & B61012 (Outlet)	YC2Z 7B028 BA.....	B61016	12351490.....	✧A63001
F6DZ 7A030 CA.....	B61046	YC2Z 7B028 DA.....	✧A63001	12472193.....	B64265
F6DZ 7A030 EA.....	A61070	YC2Z 7C028 BA.....	✧A63001	12472194.....	B64266
F6DZ 7A031 DA.....	A61069	YC2Z 7C410 AA.....	✧A63000	12472195.....	B64243
F6DZ 7A031 EA.....	A61071	YC2Z 7C410 CA.....	✧A63000	12472196.....	B64244
F6DZ 7A031 FA.....	B61013	YC2Z 7C410 EA.....	✧A63001	12472199.....	B64277
F6SZ 7D273 AA.....	②A63050	YC3Z 7A031 AA.....	B61100	12472200.....	B64278
F67Z 7A030 VA.....	B61183	YC3Z 7A031 CA.....	B61285	12472212.....	B64273
F67Z 7A031 UA.....	B61184	YC3Z 7B028 AA.....	B61275	12472217.....	B64235
F7DZ 7A030 BA.....	A61014	YC3Z 7C410 AB.....	A61276	12472218.....	B64236
F7DZ 7D273 AA.....	A63076	YL3Z 7A031 BC.....	B61282	12472219.....	B64206
F7TZ 7F112 DC.....	A61019	00137399.....	②A63013	12472220.....	B64207
F7TZ 7F112 EB.....	A61017	0118749.....	A63042	12472221.....	B64200
F7TZ 7F113 DD.....	B61193	01324714.....	✧A63004	12472222.....	B64201
F7UZ 7A030 BA.....	B61306	01639794.....	✧A63000	12472223.....	A64000
F7UZ 7A030 HA.....	B61308	01649753.....	✧A63000	12472224.....	A64001
F7UZ 7A030 JA.....	B61307	01649754.....	✧A63000	12472225.....	B64267
F75Z 7A030 AA.....	B61186	02891262.....	A63101	12472226.....	B64268
F75Z 7A030 GA.....	B61187	03460394.....	✧A63001	12472230.....	B64270
F75Z 7A030 LA.....	B61188	03520925.....	✧A63004	12472234.....	B64269
F75Z 7A030 MA.....	B61189	03520927.....	✧A63004	12472257.....	A64002
F75Z 7A031 AA.....	B61190	03520928.....	✧A63004	12472258.....	A64275
F75Z 7A031 LA.....	B61191	03520929.....	✧A63004	12472259.....	B64276
F75Z 7C410 EA.....	B61192	03532810.....	A63087	12472260.....	B64237
F8AZ 7A031 BA.....	B61016 (Outlet)		& A63001 22 1/2"	12472261.....	B64238
F81Z 7A030 AA.....	B61047	03539657.....	A61140	12472263.....	B64251
F81Z 7A030 CA.....	B61283	03539658.....	B61137	12472264.....	B64255
F81Z 7A031 CE.....	B61284	03540435.....	B61143	12472265.....	B64252
F81Z 7A031 FA.....	B61305	03544702.....	B61105	12472277.....	B64208
F81Z7A030AA.....	B61047	03750950.....	✧A63005	12472278.....	B64209
F85Z 7A031 BA.....	B61194	08637742.....	A63006	12472279.....	B64245
F87Z 7A030 FA.....	B61291	08651654.....	A63007	12472280.....	B64246
F87Z 7A030 JA.....	B61286	08676164.....	A63008	12472281.....	B64212
F87Z 7A030 KA.....	B61277	08679368.....	A63089	12472282.....	B64213
F87Z 7A030 LA.....	B61278	08680235.....	A63090	12472283.....	B64217
F87Z 7A030 VA.....	B61288	09440044.....	A63006	12472284.....	B64227
F87Z 7A031 FA.....	B61290	1C2Z 7A031 BA.....	B61310	12472285.....	B64218
F87Z 7A031 HA.....	B61287	1C3Z 7R081 AB.....	✧A63001	12472286.....	B64228
F87Z 7A031 KA.....	B61280	10080293.....	✧A63004	12472287.....	B64256
F87Z 7A031 UA.....	B61281	10080294.....	A63004	12472288.....	B64257
F87Z 7C410 LA.....	B61279	10108218.....	A61246	12472289.....	B64254
F87Z 7C410 VA.....	B61289	10108219.....	A61247	12472290.....	B64253
J3187949.....	A63040	10133086.....	✧A63000	12472293.....	B64216
J4006662.....	A63041	10145011.....	✧A63000	12472294.....	B64226
J5361661.....	✧A63001	10205231.....	A61052	12472295.....	B64247
J8125814.....	✧A63000	10254586.....	B61237	12472296.....	B64248
		10269715.....	A63013	12472299.....	B64239
		10271556.....	B61295	12472302.....	B64271
		10271560.....	B61294	12472303.....	B64272
		10273348.....	B61053	12472304.....	B64202

② Two Required.

④ Four Required.

✧ Cut To Fit.

## Manufacturers' Part Numbers - Oil Cooler Assemblies

Mr. Part No.	Our No.	Mr. Part No.	Our No.	Mr. Part No.	Our No.
12472305	B64203	15809057	B61263	25623918	B61110
12472306	B64260	15812029	B61313	25624176	B61009
12472307	B64261	15953702	B64204	25624177	B61241
12472308	B64263	15953703	B64205	25658709	A61300
12472309	B64264	15978416	B61109	25658710	B61106
12472311	B64219	15980548	B61159	25659161	A61243
12472312	B64214	15980549	B61165	25659245	B61273
12472313	B64258	15980550	B61235	25660782	B61111
12472314	B64215	15980571	B61169	25663925	B61293
12472315	B64259	15980574	A61172	25663931	B61112
12472316	B64241	15982250	B64223	25742502	B61292
12472318	B64242	15982251	B64221	3W1Z 7A030 AA	A63000
12472320	B64240	15982923	B61211	3544702	B61105
12541500	⊗A63004	15983143	B61212	373603 S2	A63107
1324714	⊗A63004	15985753	B64231	3750950	⊗A63005
15027494	B61269	15985759	B64229	377159 S	⊗A63090
15051890	B61055	15985760	B64230	389498 S2	⊗A63047
15051892	B61056	15986636	A61231	4C2Z 7A031 JC	B61309
15051894	A61028	15986637	B61214	4026139	⊗A63000
15051895	A61027	15986641	B61215	4266730	⊗A63093
15051898	B61057	15988860	B61216	4401787	⊗A63093
15051900	B61058	15990062	A61217	4418154	⊗A63004
15052170	B61259	15990594	B61216	4418159	⊗A63005
15052176	B61311	15990597	A61219	4546557	A61061 (Inlet)
15052177	B61260	15992985	A61220		& A61062 (Outlet)
15052180	A61314	15995056	B61254	4546693	B61038
15052182	B61261	15995058	B61253	4546713	A61075
15052879	B61262	15995067	B61252	4546814	A61039
15052881	B61263	15996169	B61240	4592134	⊗A63001
15052883	B61264	21631-2B001	A61023	4592162	A61079
15052884	B61265	21632-2B000	A61022	4592177	⊗A63001
15052885	B61266	21632-2B001	A61022	4610051	A61080
15052886	B61267	22538650	A61248	4617989	A61049 (Hose)
15053195	B61042	22540192	A61222		& B61101 (Tube)
15053198	B61043	22540193	A61223	4617992	B61258
15053317	B61250	22545519	A61248	4644662	A61063
15053318	B61251	22545701	A61224	4644663	B61064
15074199	B64233	22555478	A61225	4677380	A61082
15074201	B64234	22555479	A61226	4682279	A61084 (Inlet)
15074204	B64262	22576025	A61227		& A61083 (Outlet)
15112870	B64210	22576026	A61228	4682360	A61086 (Inlet)
15112871	B64211	22578998	A61227		& A61085 (Outlet)
15112872	B64231	22578999	A61229	4682467	A61087 (Inlet)
15112873	B64232	22579789	A61230		& A61085 (Outlet)
15127518	B64274	22579790	A61231	4682532	A61089 (Inlet)
15190202	B61313	22579791	A61150		& A61088 (Outlet)
15190205	B61312	22579792	A61249	4682555	A61091 (Inlet)
15190207	B61264	22645906	B61232		& A61090 (Outlet)
15194577	B64224	22645907	B61233	4682647	A61093 (Inlet)
15194578	B64225	22645913	A61002		& A61092 (Outlet)
15194579	B64220	22645914	A61003	4682649	A61094 (Inlet)
15233586	B61292	22651564	B61119		& A61092 (Outlet)
15233587	B61293	22651565	A61134	4682741	B61065 (Inlet)
15637403	A63110	24202550	A63008		& B61066 (Outlet)
15637602	A63091	24205102	A63021	4698960AD	B61068
15714053	B61268	24205103	A63098	4698965AD	B61067
15718023	⊗A63017	24207013	A63027	4728643	B61116
15719695	A63018	24212854	A63025	4758186AB	A61072
15723417	B61059	24212855	A63063	4758187	B61073
15723421	B61060	24213958	A63064	4758916	B61011
15724728	A63019	25527166	A61044	4758925	B61010
15725180	A63011	25527167	A61045	4798875AB	A61097
15738129	B64249	25533256	A61034	4798876AB	A61098
15738138	B64250	25533258	B61037	4809136AA	A61007
15738179	⊗A63068	25533260	B61033	4809262AD	A61102 (Inlet)
15745473	B61107	25533850	B61036		& A61006 (Outlet)
15745475	B61108	25533851	B61032	4809375AB	A61074 (Inlet)
15745476	B61026	25533852	A61035		& A61008 (Outlet)
15745477	B61029	25606750	B61242	4809380AC	A61096 (Inlet)
15748403	B61025	25606751	B61245		& A61095 (Outlet)
15764375	B64222	25615305	B61244	4809390	A61074 (Inlet)
15765052	B61312	25615306	A61274		& A61008 (Outlet)
15765054	B61313	25615308	A61271	4856541	A61040
15765447	B61270	25623761	B61272	4856542	A61041

⊗ Two Required.

④ Four Required.

⊗ Cut To Fit.

Product Section

Troubleshooting

EOC Applications

TOC Applications

Numerical Listing

Manufacturers' Part Numbers

End Fittings

Illustrations

# Manufacturers' Part Numbers - Oil Cooler Assemblies

Mfr. Part No.	Our No.	Mfr. Part No.	Our No.	Mfr. Part No.	Our No.
4883317AB .....	A61130	52028654AF .....	A61152 (Hose)	52028668AE .....	B61168
4883709AA .....	B61104		& B61151 (Tube)	52028897AB .....	A61162
4883710AA .....	A61131	52028655AF .....	B61153	52029303AB .....	A61049 (Hose)
4883802AB .....	B61132	52028656AF .....	B61154		& B61204 (Tube)
4883803AB .....	B61133	52028658AB .....	B61209	52029303AC .....	A61156 (Hose)
4883804AB .....	A61136 (Hose)	52028659 .....	A61171 (Hose)		& B61204 (Tube)
	& B61135 (Tube)		& B61170 (Tube)	52079387 .....	B61257
4883806AB .....	A61136 (Hose)	52028662 .....	B61123	52079588 .....	A61125
	& B61138 (Tube)	52028670AH .....	A61156 (Hose)	52079589 .....	A61126
4897790AA .....	A61049 (Hose)		& B61155 (Tube)	52079590 .....	B61127
5003096AC .....	A61139	52028671AD .....	A61158 (Hose)	52079591 .....	A61128
5003714AA .....	A61049 (Hose)		& B61157 (Tube)	52079633AB .....	✕ A63001
	& B61048 (Tube)	52028672AD .....	B61020	52079676AB .....	A61174
5011244AA .....	A61142	52028673 .....	B61050	52079677AB .....	B61207
5013845AA .....	A61145 (Hose)	52028675 .....	A61142	52079692AB .....	B61210
	& B61144 (Tube)	52028753AG .....	A61162 (Hose)	52117602 .....	B61129 (Inlet)
5016741AA .....	A61162		& B61200 (Tube)	52117708 .....	✕ A63000
5066237AA .....	A61206	52028753AK .....	A61162 (Hose)	52118001 .....	✕ A63001 (Hose)
5066448AA .....	A61174		& B61200 (Tube)		& ✕ A63005 (Tube)
52027674 .....	B61103	52028757 .....	A61171 (Hose)	52118569 .....	B61256
52027675 .....	B61051		& B61201 (Tube)	52481097 .....	A63065
52027677 .....	A61113	52028761 .....	B61124	52481248 .....	A63098
52027684 .....	A61099	52028764AA .....	A63033	52482153 .....	A63108
52027867 .....	A61114	52028767AI .....	A61156 (Hose)	52493008 .....	② A63067
52027994 .....	A61115		& B61160 (Tube)	5278603AA .....	A61077
52028328 .....	B61117	52028769AE .....	B61018	5278604AA .....	A61078
52028391 .....	A61118	52028782AH .....	A61162 (Hose)	5278605AA .....	A61075
52028475AB .....	A61158		& B61161 (Tube)	5278606AA .....	A61076
52028504 .....	A61121 (Hose)	52028782AJ .....	A61162 (Hose)	53002867 .....	✕ A63001 (Hose)
	& B61120 (Tube)		& B61202 (Tube)		& ✕ A63005 (Tube)
52028504 Chrysler .....	A61121 (Hose)	52028783AF .....	A61152 (Hose)	53002868 .....	✕ A63001
	& B61120 (Tube)		& B61163 (Tube)	6033879 .....	A63035
52028563 .....	B61255	52028784AE .....	B61164	8C 2269 A .....	✕ A63004
52028566 .....	B61122	52028784AG .....	B61164	83503727 .....	A63096
52028566AD .....	B61146	52028785AF .....	B61205	83506500 .....	✕ A63001
52028605 .....	B61208	52028812AC .....	A61049 (Hose)	87944 S8 .....	② A63011
52028605AD .....	B61147		& B61203 (Tube)	88960976 .....	② A63099
52028629 .....	② A63032	52028817AD .....	A61152 (Hose)	90105855 .....	A63102
52028645AE .....	A61149 (Hose)		& B61166 (Tube)	99562 1200 .....	② A63100
	& B61199 (Tube)	52028819AD .....	B61167	99562 1400 .....	② A63103
52028646AG .....	A61149 (Hose)	52028841AF .....	B61024	99562 1600 .....	A63104
	& B61148 (Tube)	52028841AG .....	B61024		

② Two Required.

④ Four Required.

✕ Cut To Fit.

# END FITTING CLASSIFICATION GUIDE

EOC	Length
<b>1/2" 90° Male Flared Quick Connect x 20MM Male O-Ring</b>	
B64212	47 5/8"
B64214	55 1/2"
<b>1/2" 90° Male Flared Quick Connect x 3/4" Male O-Ring</b>	
B64213	52 3/4"
B64215	60"
<b>1/2" Female O-Ring x 3/4" Male Fixed</b>	
B64277	44 5/8"
B64278	43"
<b>1/2" Male Flared Quick Connect x 1/2" Male Flared Quick Connect</b>	
B64233	49 7/8"
B64234	43"
<b>1/2" Male Flared Quick Connect x 20MM Male O-Ring</b>	
B64229	46 7/8"
B64230	53 1/4"
B64231	48 7/8"
B64232	53"
B64249	46"
B64250	42 3/8"
B64274	49 3/4"
B64210	45 1/2"
B64211	52 1/2"
<b>1/2" Male Single Beaded Quick Connect x 20MM Male O-Ring</b>	
B64208	51 7/8"
B64209	45 1/2"
B64218	48 1/2"
B64227	49 1/4"
B64228	44"
B64245	45 7/8"
B64246	52 7/8"
B64247	49 1/4"
B64248	46 1/4"
B64267	54 5/8"
B64268	44 1/2"
B64269	47 5/8"
B64270	46 7/8"
B64271	48 1/4"
B64272	44 3/4"
B64273	51 5/8"
<b>1/2" Male Single Beaded Quick Connect x 3/4" Male O-Ring</b>	
B64216	46 7/8"
B64217	44 7/8"
B64226	50 5/8"

EOC	Length
<b>20MM Male O-Ring x 20MM Male O-Ring</b>	
B64200	44 3/8"
B64201	34 1/4"
B64202	47 1/4"
B64203	54 1/2"
B64204	64 1/2"
B64205	51 1/2"
B64235	51"
B64236	41 1/8"
B64237	47 7/8"
B64238	57 5/8"
B64239	53 1/4"
B64240	61 7/8"
B64241	45"
B64242	35 1/2"
B64263	45 5/8"
B64264	44 3/8"
<b>3/4" Female O-Ring x 20MM Male O-Ring</b>	
B64206	62"
B64207	56 1/8"
B64243	43 5/8"
B64244	43 3/4"
B64265	47 1/2"
B64266	47 3/4"
<b>3/4" Female x 3/4" Male Fixed</b>	
A64000	16"
A64001	14 7/8"
<b>3/4" Fixed Male x 20MM Male O-Ring</b>	
A64002	15 1/2"
B64275	28"
B64276	27 3/4"
<b>90° Male Flared Quick Connect x 20MM Male O-Ring</b>	
B64251	70 1/4"
B64252	73 3/4"
B64253	72 5/8"
B64254	49 7/8"
B64255	49 3/4"
B64256	49"
B64257	47 3/4"
B64258	56 5/8"
B64259	60 1/2"
<b>Block Fitting x 1/2" Male Flared Quick Connect</b>	
B64224	50 1/2"
B64225	40 1/4"
B64262	52 7/8"
B64222	53 1/2"
<b>Block Fitting x 20MM Male O-Ring</b>	
B64260	30 5/8"
B64261	32 5/8"
B64223	42 1/2"
<b>Block Fitting x Block Fitting</b>	
B64219	46 1/4"
B64220	27 3/4"
B64221	31"

Product Section

Troubleshooting

EOC Applications

TOC Applications

Numerical Listing

Manufacturers' Part Numbers

End Fittings

Illustrations

# END FITTING CLASSIFICATION GUIDE

Product Section

Troubleshooting

EOC Applications

TOC Applications

Numerical Listing

Manufacturers' Part Numbers

End Fittings

Illustrations

TOC	Length
<b>1/2" Female Inv. Flare x 1/2" Male Inv. Flare</b>	
B61129	42 3/4"
B61141	35 5/8"
B61157	62 3/8"
<b>1/2" Female Inv. Flare x 1/2" Male S.A.E.</b>	
A61142	7 5/8"
<b>1/2" Female Quick Connect x 1/2" I.D. Molded Hose</b>	
A61097	17 5/8"
A61098	19 1/2"
<b>1/2" Female Quick Connect x 1/2" Male Inv. Flare</b>	
B61020	90 1/4"
<b>1/2" Female Quick Connect x 1/2" Male S.A.E.</b>	
A61158	12 1/2"
<b>1/2" Male Inv. Flare x 1/2" Single Bead Quick Connect</b>	
B61050	56 3/4"
<b>3/8" Beaded Tube x 3/8" Single Bead Quick Connect</b>	
B61051	34 1/4"
<b>3/8" Double Beaded Quick Connect x 3/8" I.D. Molded Hose</b>	
A61014	34 1/8"
A61069	35 1/4"
A61070	28 7/8"
A61071	35 5/8"
<b>3/8" Female Inv. Flare x 3/8" Female Inv. Flare</b>	
B61135	51 1/8"
B61138	57 1/2"
B61148	46 3/8"
B61151	57 1/2"
B61155	72 3/8"
B61160	63 1/2"
B61161	52 1/2"
B61163	57 7/8"
B61166	58 3/4"
B61170	46 1/2"
B61173	41 1/2"
B61199	45 1/8"
B61200	51 3/4"
B61201	42 1/4"
B61202	53 1/2"
B61203	54 1/2"
B61204	70 1/8"
B61207	49"

TOC	Length
<b>3/8" Female Inv. Flare x 3/8" Female Quick Connect</b>	
B61018	90 1/2"
B61132	61 3/8"
B61133	72 1/2"
B61153	72 3/8"
B61154	75 3/4"
B61164	72 1/4"
B61167	74 1/4"
B61168	86"
B61205	75 1/2"
<b>3/8" Female Inv. Flare x 3/8" I.D. Hose</b>	
A61130	16 1/2"
<b>3/8" Female Inv. Flare x 3/8" I.D. Molded Hose</b>	
B61010	61 1/8"
B61011	50"
B61067	49 1/2"
B61068	58 7/8"
<b>3/8" Female Inv. Flare x 3/8" Male Single Bead Quick Connect</b>	
A61114	3 1/2"
A61118	7"
A61125	21 7/8"
B61024	55 5/8"
B61101	65 1/4"
B61103	24"
B61104	22 1/2"
B61117	28 1/4"
B61120	51 1/2"
B61123	57 1/4"
B61124	55 3/4"
B61209	52 5/8"
B61258	38 3/4"
<b>3/8" Female Quick Connect x 3/8" I.D. Hose</b>	
A61139	9 1/2"
<b>3/8" Female Quick Connect x 3/8" Male S.A.E.</b>	
A61145	15 1/4"
A61152	15 1/2"
A61156	12 5/8"
A61162	15 1/2"
A61136	10 1/2"
A61174	14"
A61206	11"
<b>3/8" Female Quick Connect x 3/8" Male Single Bead Quick Connect</b>	
B61122	76 1/2"
B61146	58"
B61147	74 1/4"
B61175	64 3/4"
B61208	53 3/8"
B61210	77"
B61255	77"

TOC	Length
<b>3/8" Female S.A.E. x 3/8" Female Quick Connect</b>	
A61049	11 3/4"
<b>3/8" Female S.A.E. x 3/8" Female S.A.E</b>	
B61048	73 1/2"
<b>3/8" I.D. Hose x 3/8" O.D. Male Beaded Tube</b>	
B61245	44 1/2"
<b>3/8" I.D. Molded Hose</b>	
A61099	3 1/2"
<b>3/8" Long Male Inv. Flare x 3/8" Double Beaded Tube</b>	
B61279	37 1/2"
B61289	37 1/2"
<b>3/8" Long Male Inv. Flare x 3/8" I.D. Hose</b>	
B61310	50 1/2"
<b>3/8" Long Male Inv. Flare x 3/8" Long Male Inv. Flare</b>	
B61190	90 1/4"
B61193	37 1/2"
<b>3/8" Long Male Inv. Flare x 3/8" Male Inv. Flare</b>	
B61100	75 1/2"
B61184	86 5/8"
B61186	96 1/2"
B61194	94"
B61198	93 3/4"
B61277	67 3/4"
B61280	80 1/2"
B61281	86 1/4"
B61282	93"
B61285	81 3/4"
B61287	76 1/4"
B61290	66 1/8"
B61291	54 3/4"
B61305	88 3/4"
<b>3/8" Long Male Inv. Flare x 5/16" Male Inv. Flare</b>	
B61196	80"
B61197	87 3/4"
<b>3/8" Male "O" Ring x 3/8" Beaded Tube</b>	
B61073	33 7/8"
<b>3/8" Male "O" Ring x 3/8" Molded Hose</b>	
A61072	23 5/8"
<b>3/8" Male Flared Quick Connect x 3/8" Male Flared Quick Connect</b>	
A61314	37"
B61026	102 5/8"
B61029	82 1/4"
B61042	52 3/4"
B61043	64 3/4"
B61058	73 3/4"
B61107	81"
B61108	81 1/2"

TOC	Length
<b>3/8" Male Flared Quick Connect x 3/8" Male Flared Quick Connect cont.</b>	
B61250	55 1/2"
B61251	63 1/4"
B61252	69 3/4"
B61253	73 3/8"
B61254	93 5/8"
B61259	64"
B61260	72 1/2"
B61261	116 1/4"
B61262	71 3/4"
B61263	50 1/2"
B61264	46"
B61265	81 1/4"
B61266	79 3/4"
B61267	77 1/4"
B61268	61 3/8"
B61269	66 3/4"
B61270	67 1/4"
B61292	45 3/4"
B61293	55 3/8"
B61311	68 1/4"
B61312	69 1/4"
B61313	89 3/4"
<b>3/8" Male Inv. Flare x 3/8" Double Beaded Tube</b>	
A61019	6"
A61113	19 5/8"
B61047	57"
B61110	61"
B61116	23 5/8"
B61127	41"
B61278	52 3/4"
B61283	59 1/8"
B61284	49 3/8"
B61286	53 1/4"
B61288	54 1/4"
B61306	55 5/8"
<b>3/8" Male Inv. Flare x 3/8" I.D. Hose</b>	
A61030	28 1/4"
A61031	23 1/4"
A61140	23 1/2"
B61053	52 3/8"
B61054	71 1/4"
B61137	63 1/4"
B61187	74 1/4"
B61275	48"
<b>3/8" Male Inv. Flare x 3/8" Male Flared Quick Connect</b>	
A61027	38 1/4"
A61028	28 3/8"
B61025	45 1/2"
B61055	65 1/4"
B61056	39 3/4"
B61057	71 3/4"
B61059	81 1/4"
B61060	69 1/8"
B61238	47 5/8"
B61239	53 1/2"
B61240	38 1/2"

Product Section

Troubleshooting

EOC Applications

TOC Applications

Numerical Listing

Manufacturers' Part Numbers

End Fittings

Illustrations

# END FITTING CLASSIFICATION GUIDE

Product Section

Troubleshooting

EOC Applications

TOC Applications

Numerical Listing

Manufacturers' Part Numbers

End Fittings

Illustrations

TOC	Length
<b>3/8" Male Inv. Flare x 3/8" Male Inv. Flare</b>	
A61134	33 1/4"
B61009	51 1/2"
B61105	60 3/8"
B61106	57 1/2"
B61111	53 3/4"
B61112	61"
B61119	42 1/8"
B61143	67 1/4"
B61241	62 5/8"
B61272	42 3/4"
B61273	54 1/8"
<b>3/8" Male Inv. Flare x 3/8" Male Single Bead Quick Connect</b>	
A61131	11 1/8"
B61144	46 1/4"
<b>3/8" Male Inverted Flare x 3/8" Beaded Tube</b>	
B61183	52 1/8"
A61271	6 1/4"
A61274	14 3/4"
<b>3/8" Male Inverted Flare x 3/8" I.D. Hose</b>	
A61236	25 5/8"
A61243	26 1/2"
A61276	24 3/4"
B61242	45 3/4"
<b>3/8" Male Inverted Flare x 3/8" Male Inv. Flare</b>	
A61300	21 3/8"
<b>3/8" Male Inverted Flare x 3/8" O.D. Beaded Tube</b>	
B61237	26 3/4"
B61244	26"
<b>3/8" Male Inverted Flare x 5/16" I.D. Hose</b>	
A61298	24 3/4"
A61299	23 3/8"
<b>3/8" Male O-Ring x 3/8" I.D. Molded Hose</b>	
A61040	24"
<b>3/8" Male O-Ring x 3/8" O.D. Male Beaded Tube</b>	
A61041	20"
<b>3/8" Male S.A.E x 3/8" Female Quick Connect</b>	
A61121	12 5/8"
<b>3/8" Male S.A.E. x 3/8" Male Single Bead Quick Connect</b>	
A61149	13 5/8"
A61171	12"
<b>3/8" Male Single Bead Quick Connect x 3/8" Double Beaded Tube</b>	
A61115	20 7/8"
<b>3/8" Male Single Bead Quick Connect x 3/8" Male Single Bead Quick Connect</b>	
B61256	61 3/4"
B61257	58"

TOC	Length
<b>3/8" Male Single Bead Quick Connect x 3/8" Single Bead Tube</b>	
A61126	25 3/4"
A61128	18"
<b>3/8" Single Bead Quick Connect x 3/8" Double Beaded Quick Connect</b>	
B61013	57 5/8"
B61046	44 5/8"
<b>5/16" Double Beaded Tube x 3/8" Male Flared Quick Connect</b>	
B61295	69 1/4"
B61297	51 1/2"
<b>5/16" I.D. Hose x 5/16" I.D. Hose</b>	
B61179	32 3/8"
B61181	35 3/4"
<b>5/16" I.D. Molded Hose</b>	
A61006	15 1/2"
A61007	13 3/8"
A61008	25 1/2"
A61022	9"
A61023	20"
A61039	16 5/8"
A61061	11 1/2"
A61062	20 3/4"
A61074	25 1/2"
A61075	11 1/4"
A61076	10 3/8"
A61077	16 3/4"
A61078	9"
A61079	20"
A61080	18 1/4"
A61083	12 1/4"
A61084	21 1/2"
A61085	12 5/8"
A61086	21 3/8"
A61087	23 1/2"
A61088	10 1/8"
A61089	21"
<b>5/16" I.D. Molded Hose cont.</b>	
A61090	13 7/8"
A61091	30 3/4"
A61092	12 1/2"
A61093	19 7/8"
A61094	25 3/4"
A61095	12 1/2"
A61096	24"
A61102	18 1/4"
<b>5/16" I.D. Molded Hose x 3/8" I.D. Molded Hose</b>	
B61038	62 7/8"
<b>5/16" I.D. Molded Hose x 5/16" Beaded Tube</b>	
B61065	46 1/4"



# END FITTING CLASSIFICATION GUIDE

TOC	Length
<b>5/16" I.D. Molded Hose x 5/16" I.D. Molded Hose</b>	
B61066	43 1/4"
<b>5/16" Long Male Inv. Flare x 5/16" I.D. Hose</b>	
B61178	55 1/2"
B61180	39 1/2"
B61182	42 7/8"
<b>5/16" Long Male Inv. Flare x 5/16" Long Male Inv. Flare</b>	
B61192	37 1/2"
<b>5/16" Long Male Inv. Flare x 5/16" Male Inv. Flare</b>	
B61176	68 3/4"
B61185	52 1/2"
B61188	79 3/8"
B61191	86 5/8"
<b>5/16" Long Male Inv. Flare x 5/16" Male Single Bead Quick Connect</b>	
B61177	61 3/4"
<b>5/16" Long Male Inverted Flare x 5/16" Male Inverted Flare</b>	
B61234	78 1/4"
<b>5/16" Male Inv. Flare x 1/2" Male Flared Quick Connect</b>	
B61109	71 1/4"
<b>5/16" Male Inv. Flare x 3/8" Male Flared Quick Connect</b>	
B61294	75 1/2"
B61296	58 3/4"
<b>5/16" Male Inv. Flare x 3/8" Male Inv. Flare</b>	
A61002	28 7/8"
A61003	17"
<b>5/16" Male Inv. Flare x 5/16" Double Beaded Tube</b>	
A61017	6"
B61012	48"
B61064	25 1/2"
B61307	40 5/8"
B61308	41 7/8"
<b>5/16" Male Inv. Flare x 5/16" I.D. Hose</b>	
A61035	22"
A61052	19"
B61016	63 1/2"
B61032	61 5/8"
B61036	64 3/8"
B61189	55 1/2"
B61309	47"
<b>5/16" Male Inv. Flare x 5/16" I.D. Molded Hose</b>	
A61063	25"

TOC	Length
<b>5/16" Male Inv. Flare x 5/16" Male Inv. Flare</b>	
A61044	38 1/4"
A61045	25 1/2"
<b>5/16" Male Inv. Flare x 5/16" O.D. Beaded Tube</b>	
B61037	38 3/4"
<b>5/16" Male Inv. Flare x 5/16" O.D. Male Beaded Tube</b>	
A61034	12 5/8"
B61033	36 3/4"
<b>5/16" Male Inverted Flare x 1/2" Male Flared Quick Connect</b>	
A61172	28 1/2"
A61213	24 1/4"
A61217	36 3/4"
A61219	43"
A61220	24"
B61159	93 1/2"
B61165	72 7/8"
B61169	52 1/4"
B61211	71 1/2"
B61212	72 1/2"
B61214	53 1/2"
B61215	34 1/4"
B61216	51 1/2"
B61218	54"
B61235	72 1/2"
<b>5/16" Male Inverted Flare x 3/8" Male Inverted Flare</b>	
B61232	58 3/4"
B61233	50 3/8"
<b>5/16" Male Inverted Flare x 5/16" I.D. Hose</b>	
A61221	18"
<b>5/16" Male Inverted Flare x 5/16" Male Inverted Flare</b>	
A61150	27 1/4"
A61222	20"
A61223	39 1/4"
A61224	39"
A61225	32"
A61226	24 3/8"
A61227	17 1/2"
A61228	28 5/8"
A61229	26 1/4"
A61230	30 1/4"
A61231	33 7/8"
A61246	30 1/2"
A61247	28 1/4"
A61248	29 1/4"
A61249	32 3/4"
<b>5/8" I.D. Molded Hose</b>	
A61081	3 3/4"
A61082	5 1/2"

Product Section

Troubleshooting

EOC Applications

TOC Applications

Numerical Listing

Manufacturers' Part Numbers

End Fittings

Illustrations

# ILLUSTRATIONS

## 5/16" Male Inv. Flare x 3/8" Male Inv. Flare

**A61002**

OEM# 22645913

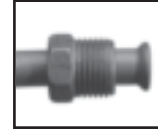

28 7/8"

Product Section

Troubleshooting

**A61003**

OEM# 22645914

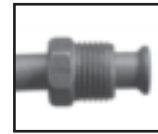
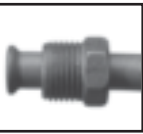

17"

EOC Applications

TOC Applications

## 5/16" I.D. Molded Hose

**A61006**

OEM# 4809262AD



15 1/2"

Numerical Listing

**A61007**

OEM# 4809136AA



13 3/8"

Manufacturers' Part Numbers

**A61008**

OEM# 4809375AB  
4809390





25 1/2"



End Fittings

Illustrations



## 3/8" Male Double Beaded Quick Connect x 3/8" I.D. Molded Hose

<b>A61014</b>	<b>OEM# F7DZ 7A030 BA</b>
	 <p data-bbox="792 439 876 470" style="text-align: center;">34 1/8"</p>

## 5/16" Male Inv. Flare x 5/16" O.D. Male Double Beaded Tube

<b>A61017</b>	<b>OEM# F7TZ 7F112 EB F75A 7F112 EC</b>
	 <p data-bbox="818 885 847 915" style="text-align: center;">6"</p>
	

## 3/8" Male Inv. Flare x 3/8" O.D. Male Double Beaded Tube

<b>A61019</b>	<b>OEM# F7TZ 7F112 DC F75A 7F112 DC</b>
	 <p data-bbox="815 1338 844 1369" style="text-align: center;">6"</p>
	

## 5/16" I.D. Molded Hose

<b>A61022</b>	<b>OEM# N/A</b>
 <p data-bbox="815 1768 844 1798" style="text-align: center;">7"</p>	

Product Section

Troubleshooting

EOC Applications

TOC Applications

Numerical Listing

Manufacturers' Part Numbers

End Fittings

Illustrations

# ILLUSTRATIONS

## 5/16" I.D. Molded Hose (continued)

**A61023**

OEM# N/A



Product Section

Troubleshooting

## 3/8" Male Inv. Flare x 3/8" Male Flared Quick Connect

**A61027**

OEM# 15051895



38 1/4"

EOC Applications

TOC Applications

**A61028**

OEM# 15051894

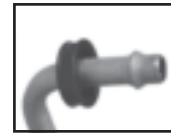
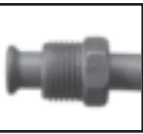

28 3/8"

Numerical Listing

## 3/8" Male Inv. Flare x 3/8" I.D. Hose

**A61030**

OEM# 10290000



28 1/4"

Manufacturers' Part Numbers

End Fittings

**A61031**

OEM# 10273666



23 1/4"

Illustrations

## 5/16" Male Inv. Flare x 5/16" O.D. Male Beaded Tube

**A61034**

OEM# 25533256

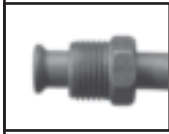

12 5/8"

## 5/16" Male Inv. Flare x 5/16" I.D. Hose

**A61035**

OEM# 25533852



22"

## 5/16" I.D. Molded Hose

**A61039**

OEM# 4546814



16 5/8"

## 3/8" Male O-Ring x 3/8" O.D. Male Beaded Tube

**A61040**

OEM# 4856541



24"

Product Section

Troubleshooting

EOC Applications

TOC Applications

Numerical Listing

Manufacturers'  
Part Numbers

End Fittings

Illustrations

# ILLUSTRATIONS

## 3/8" Male O-Ring x 3/8" O.D. Male Beaded Tube (continued)

Product Section

**A61041**

OEM# 4856542

Troubleshooting



20"

EOC Applications

## 5/16" Male Inv. Flare x 5/16" Male Inv. Flare

**A61044**

OEM# 25527166

TOC Applications

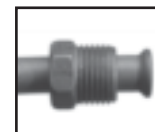

38 1/4"

Numerical Listing

## 5/16" Male Inv. Flare x 5/16" Male Inv. Flare

**A61045**

OEM# 25527167

Manufacturers' Part Numbers



25 1/2"

End Fittings

## 3/8" Female S.A.E. x 3/8" Female Quick Connect

**A61049**

OEM# 5003714AA  
52028812AC

Illustrations



11 3/4"

## 5/16" Male Inv. Flare x 5/16" I.D. Hose

**A61052**

OEM# 10205231  
10278901



19"

## 5/16" I.D. Molded Hose

**A61061**

OEM# 4546557



11 1/2"

**A61062**

OEM# 4546557

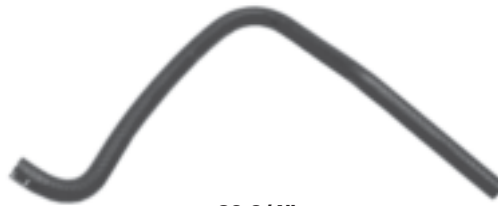

20 3/4"

## 5/16" Male Inv. Flare x 5/16" I.D. Molded Hose

**A61063**

OEM# 4644662

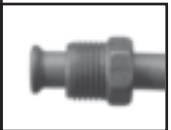

25"

Product Section

Troubleshooting

EOC Applications

TOC Applications

Numerical Listing

Manufacturers'  
Part Numbers

End Fittings

Illustrations

# ILLUSTRATIONS

Product Section

Troubleshooting

EOC Applications

TOC Applications

Numerical Listing

## 3/8" Male Double Beaded Quick Connect x 3/8" I.D. Molded Hose

**A61069**

OEM# F6DZ 7A031 DA

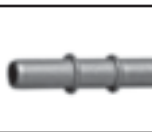

35 1/4"

**A61070**

OEM# F6DZ 7A030 EA



28 7/8"

**A61071**

OEM# F6DZ 7A031 EA



35 5/8"

## 3/8" Male O-Ring x 3/8" I.D. Molded Hose

**A61072**

OEM# 4758186AB



23 5/8"

## 5/16" I.D. Molded Hose

**A61074**

OEM# 4809375AB  
4809390



25 1/2"

Manufacturers' Part Numbers





End Fittings

Illustrations



# ILLUSTRATIONS

## 5/16" I.D. Molded Hose (continued)

<b>A61075</b>	 <p>11 1/4"</p>	<b>OEM#</b> 4546713 5278605AA
<b>A61076</b>	 <p>10 3/8"</p>	<b>OEM#</b> 5278606AA
<b>A61077</b>	 <p>16 3/4"</p>	<b>OEM#</b> 5278603AA
<b>A61078</b>	 <p>9"</p>	<b>OEM#</b> 5278604AA
<b>A61079</b>	 <p>20"</p>	<b>OEM#</b> 4592162

Product Section

Troubleshooting

EOC Applications

TOC Applications

Numerical Listing

Manufacturers' Part Numbers

End Fittings

Illustrations

# ILLUSTRATIONS

Product Section

Troubleshooting

EOC Applications

TOC Applications

Numerical Listing

Manufacturers' Part Numbers

End Fittings

Illustrations

## 5/16" I.D. Molded Hose (continued)

**A61080**

OEM# 4610051



18 1/4"

## 5/8" I.D. Molded Hose

**A61081**

OEM# 4638427



3 3/4"

**A61082**

OEM# 4677380



5 1/2"

## 5/16" I.D. Molded Hose

**A61083**





OEM# 4682279



12 1/4"

# ILLUSTRATIONS

## 5/16" I.D. Molded Hose (continued)

<b>A61084</b>	 <p>21 1/2"</p>	<b>OEM# 4682279</b>
<b>A61085</b>	 <p>12 5/8"</p>	<b>OEM# 4682360 4682467</b>
<b>A61086</b>	 <p>21 3/8"</p>	<b>OEM# 4682360</b>
<b>A61087</b>	 <p>23 1/2"</p>	<b>OEM# 4682467</b>
<b>A61088</b>	 <p>10 1/8"</p>	<b>OEM# 4682532</b>

Product Section

Troubleshooting

EOC Applications

TOC Applications

Numerical Listing

Manufacturers'  
Part Numbers

End Fittings

Illustrations

# ILLUSTRATIONS

## 5/16" I.D. Molded Hose (continued)

**A61089**

OEM# 4682532



21"

**A61090**

OEM# 4682555



13 7/8"

**A61091**

OEM# 4682555



30 3/4"

**A61092**

OEM# 4682647  
4682649



12 1/2"

**A61093**

OEM# 4682647



19 7/8"

Product Section

Troubleshooting

EOC Applications

TOC Applications

Numerical Listing



Manufacturers' Part Numbers

End Fittings





Illustrations

# ILLUSTRATIONS

## 5/16" I.D. Molded Hose (continued)

<b>A61094</b>		<b>OEM# 4682649</b>
 <p>25 3/4"</p>		
<b>A61095</b>		<b>OEM# 4809380AC</b>
 <p>12 1/2"</p>		
<b>A61096</b>		<b>OEM# 4809380AC</b>
 <p>24"</p>		

## 1/2" Female Quick Connect x 1/2" I.D. Molded Hose

<b>A61097</b>		<b>OEM# 4798875AB</b>
	 <p>17 5/8"</p>	
<b>A61098</b>		<b>OEM# 4798876AB</b>
	 <p>19 1/2"</p>	

Product Section

Troubleshooting

EOC Applications

TOC Applications

Numerical Listing

Manufacturers' Part Numbers

End Fittings

Illustrations

# ILLUSTRATIONS

## 3/8" I.D. Molded Hose

**A61099**

**OEM# 52027684**



3 1/2"

## 5/16" I.D. Molded Hose

**A61102**

**OEM# 4809262AD**



18 1/4"

## 3/8" Female Inv. Flare x 3/8" O.D. Male Beaded Tube

**A61113**

**OEM# 52027677**



19 5/8"

## 3/8" Female Inv. Flare x 3/8" Male Single Beaded Quick Connect

**A61114**

**OEM# 52027867**



3 1/2"

Product Section

Troubleshooting

EOC Applications

TOC Applications

Numerical Listing

Manufacturers' Part Numbers

End Fittings

Illustrations

# ILLUSTRATIONS

## 3/8" Male Single Beaded Quick Connect x 3/8" O.D. Male Double Beaded Tube

**A61115**

**OEM# 52027994**

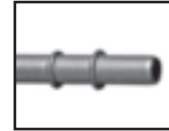

20 7/8"

## 3/8" Female Inv. Flare x 3/8" Male Single Beaded Quick Connect

**A61118**

**OEM# 52028391**



7"

## 3/8" Female Quick Connect x 3/8" Male S.A.E.

**A61121**

**OEM# 52028504**



12 5/8"

## 3/8" Female Inv. Flare x 3/8" Male Single Beaded Quick Connect

**A61125**

**OEM# 52079588**



21 7/8"

Product Section

Troubleshooting

EOC Applications

TOC Applications

Numerical Listing

Manufacturers'  
Part Numbers

End Fittings

Illustrations

# ILLUSTRATIONS

Product Section

## 3/8" Male Single Beaded Quick Connect x 3/8" O.D. Male Beaded Tube

**A61126**

OEM# 52079589



25 3/4"

Troubleshooting

EOC Applications

**A61128**

OEM# 52079591

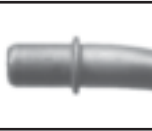

18"

TOC Applications

## 3/8" Female Inv. Flare x 3/8" I.D. Hose

**A61130**

OEM# 4883317AB



16 1/2"

Numerical Listing

Manufacturers' Part Numbers

## 3/8" Male Inv. Flare x 3/8" Male Single Beaded Quick Connect

**A61131**

OEM# 4883710AA

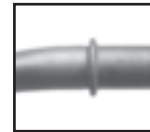

11 1/8"

End Fittings

Illustrations



## 3/8" Female Quick Connect x 3/8" I.D. Hose

**A61139**

OEM# 5003096AC



9 1/2"

## 3/8" Male Inv. Flare x 3/8" I.D. Hose

**A61140**

OEM# 03539657



23 1/2"

## 1/2" Female Quick Connect x 1/2" Male S.A.E.

**A61142**

OEM# 5011244AA  
52028675



7 5/8"

## 3/8" Female Quick Connect x 3/8" Male S.A.E.

**A61145**

OEM# 5013845AA



15 1/4"

# ILLUSTRATIONS

Product Section

## 3/8" Male S.A.E. x 3/8" Male Single Beaded Quick Connect

**A61149**

**OEM#** 52028645AE  
52028646AG

Troubleshooting

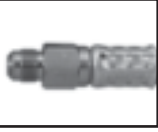

13 5/8"

EOC Applications

## 5/16" Male Inv. Flare x 5/16" Male Inv. Flare

**A61150**

**OEM#** 22579791

TOC Applications

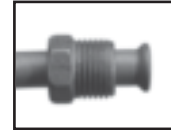

27 1/4"

Numerical Listing

## 3/8" Female Quick Connect x 3/8" Male S.A.E.

**A61152**

**OEM#** 5016741AA,  
52028654AF,  
52028783AF,  
52028817AD

Manufacturers' Part Numbers



15 1/2"

End Fittings

**A61156**

**OEM#** 52028670AH,  
52028767AI,  
52029303AC

Illustrations





12 5/8"

## 1/2" Female Quick Connect x 1/2" Male S.A.E.

<b>A61158</b>	<b>OEM#</b> 52028475AB 52028671AD
	
	
12 1/2"	



## 3/8" Female Quick Connect x 3/8" Male S.A.E.

<b>A61162</b>	<b>OEM#</b> 52028654AG, 52028753AG, 52028753AK, 52028782AH, 52028897AB
	
	
15 1/2"	

## 3/8" Male S.A.E. x 3/8" Male Single Beaded Quick Connect

<b>A61171</b>	<b>OEM#</b> 52028757
	
	
12"	

## 5/16" Male Inv. Flare x 1/2" Male Flared Quick Connect

<b>A61172</b>	<b>OEM#</b> 15980574
	
	
28 1/2"	

Product Section

Troubleshooting

EOC Applications

TOC Applications

Numerical Listing

Manufacturers'  
Part Numbers

End Fittings

Illustrations

Product Section

## 3/8" Female Quick Connect x 3/8" Male S.A.E.

**A61174**

OEM# 5066448AA  
52079676AB



14"

Troubleshooting

**A61206**

OEM# 5066237AA



11"

EOC Applications

TOC Applications

## 5/16" Male Inv. Flare x 1/2" Male Flared Quick Connect

**A61213**

OEM# 15986636

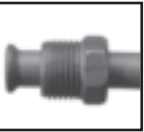

24 1/4"

Numerical Listing

**A61217**

OEM# 15990062



36 3/4"

Manufacturers' Part Numbers

End Fittings

**A61219**



OEM# 15990597





43"



Illustrations

## 5/16" Male Inv. Flare x 1/2" Male Flared Quick Connect (continued)



<b>A61220</b>	<b>OEM# 15992985</b>	
	 <p data-bbox="803 429 852 459">24"</p>	



## 5/16" Male Inv. Flare x 5/16" I.D. Hose

<b>A61221</b>	<b>OEM# 10430945</b>	
	 <p data-bbox="803 838 852 868">8"</p>	

<b>A61222</b>	<b>OEM# 22540192</b>	
	 <p data-bbox="803 1124 852 1154">20"</p>	

## 5/16" Male Inv. Flare x 5/16" Male Inv. Flare

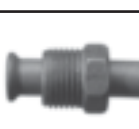
<b>A61223</b>	<b>OEM# 22540193</b>	
	 <p data-bbox="787 1543 885 1573">39 1/4"</p>	

<b>A61224</b>	<b>OEM# 22545701</b>	
	 <p data-bbox="803 1849 852 1880">39"</p>	

Product Section

Troubleshooting

EOC Applications

TOC Applications

Numerical Listing

Manufacturers' Part Numbers

End Fittings

Illustrations

# ILLUSTRATIONS

## 5/16" Male Inv. Flare x 5/16" Male Inv. Flare (continued)

Product Section

Troubleshooting

EOC Applications

TOC Applications

Numerical Listing

Manufacturers' Part Numbers

End Fittings

Illustrations

**A61225**

OEM# 22555478

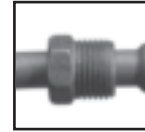
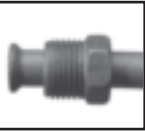

32"

**A61226**

OEM# 22555479



24 3/8"

**A61227**

OEM# 22576025  
22578998



17 1/2"

**A61228**

OEM# 22576026



28 5/8"





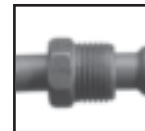

**A61229**

OEM# 22578999









26 1/4"

## 5/16" Male Inv. Flare x 5/16" Male Inv. Flare (continued)

<b>A61230</b>		<b>OEM# 22579789</b>
		
30 1/4"		
<b>A61231</b>		<b>OEM# 22579790</b>
		
33 7/8"		

## 3/8" Male Inv. Flare x 3/8" I.D. Hose

<b>A61236</b>		<b>OEM# 10416317</b>
		
25 5/8"		
<b>A61243</b>		<b>OEM# 25659161</b>
		
26 1/2"		
<b>A61246</b>		<b>OEM# 10108218</b>
		
30 1/2"		

Product Section

Troubleshooting

EOC Applications

TOC Applications

Numerical Listing

Manufacturers' Part Numbers

End Fittings

Illustrations

## 5/16" Male Inv. Flare x 5/16" Male Inv. Flare

**A61247**

OEM# 10108219

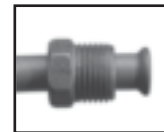

28 1/4"

**A61248**

OEM# 22538650  
22545519

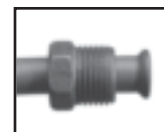

29 1/4"

**A61249**

OEM# 22579792



32 3/4"

## 3/8" Male Inverted Flare x 3/8" Beaded Tube

**A61271**

OEM# 25615308



Outlet Tube 6 1/4"

**A61274**

OEM# 25615306



Inlet Tube 14 3/4"

Product Section

Troubleshooting

EOC Applications

TOC Applications

Numerical Listing

Manufacturers' Part Numbers













End Fittings

Illustrations

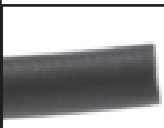



# ILLUSTRATIONS

## 3/8" Male Inverted Flare x 3/8" Beaded Tube (continued)

<b>A61276</b>	<b>OEM# YC3Z 7C410 AB</b>	
		
Inlet Hose 24 3/4"		
<b>A61298</b>	<b>OEM# 10288031</b>	
		
Inlet Hose 24 3/4"		
<b>A61299</b>	<b>OEM# 10288032</b>	
		
Outlet Hose 23 3/8"		
<b>A61300</b>	<b>OEM# 25658709</b>	
		
Outlet Hose 21 3/8"		

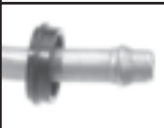
## 3/8" Male Flared Quick Connect x 3/8" Male Flared Quick Connect

<b>A61314</b>	<b>OEM# 15052180</b>	
		
Inlet Hose 37"		

Product Section

Troubleshooting

EOC Applications

TOC Applications

Numerical Listing

Manufacturers' Part Numbers

End Fittings

Illustrations

## 3/4" Female x 3/4" Fixed Male

**A64000**

OEM# 12472223



Inlet Hose 16"

**A64001**

OEM# 12472224



Outlet Hose 14 7/8"

## 3/4" Fixed Male x 20mm Male O-Ring

**A64002**

OEM# 12472257



Inlet/Outlet Hose 15 1/2"

## 3/8" Male Inv. Flare x 3/8" Male Inv. Flare

**B61009**

OEM# 25624176



51 1/2"

## 3/8" Female Inv. Flare x 3/8" I.D. Molded Hose

**B61010**

OEM# 4758925



61 1/8"

Product Section

Troubleshooting

EOC Applications

TOC Applications

Numerical Listing

Manufacturers' Part Numbers

End Fittings

Illustrations

## 3/8" Female Inv. Flare x 3/8" I.D. Molded Hose (continued)

**B61011**

OEM# 4758916

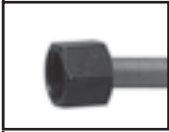

50"

## 5/16" Male Inv. Flare x 5/16" O.D. Male Double Beaded Tube

**B61012**

OEM# F6AZ 7A031 AA

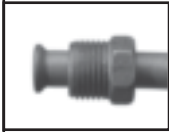

48"

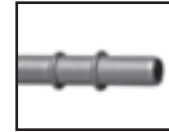

## 3/8" Male Single Beaded Quick Connect x 3/8" Male Double Beaded Quick Connect

**B61013**

OEM# F6DZ 7A031 FA



57 5/8"

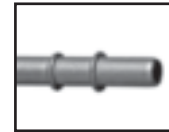

## 5/16" Male Inv. Flare x 5/16" I.D. Hose

**B61016**

OEM# F7TZ 7F112 EB  
F75A 7F112 EC



63 1/2"

## 3/8" Female Inv. Flare x 3/8" Female Quick Connect

**B61018**

OEM# 52028769AE



90 1/2"

Product Section

Troubleshooting

EOC Applications

TOC Applications

Numerical Listing

Manufacturers'  
Part Numbers

End Fittings

Illustrations

Product Section

## 1/2" Female Quick Connect x 1/2" Male Inv. Flare

**B61020**

OEM# 52028672AD

Troubleshooting

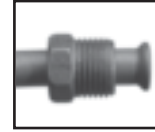

90 1/4"

EOC Applications

## 3/8" Female Inv. Flare x 3/8" Male Single Beaded Quick Connect

**B61024**

OEM# 52028841AG

TOC Applications



55 5/8"

Numerical Listing

## 3/8" Male Inv. Flare x 3/8" Male Flared Quick Connect

**B61025**

OEM# 15748403

Manufacturers' Part Numbers

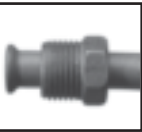

45 1/2"

End Fittings

## 3/8" Male Flared Quick Connect x 3/8" Male Flared Quick Connect

**B61026**

OEM# 15745476

Illustrations



102 5/8"

**B61029**

OEM# 15745477



82 1/4"

## 5/16" Male Inv. Flare x 5/16" I.D. Hose

**B61032**

**OEM# 25533851**

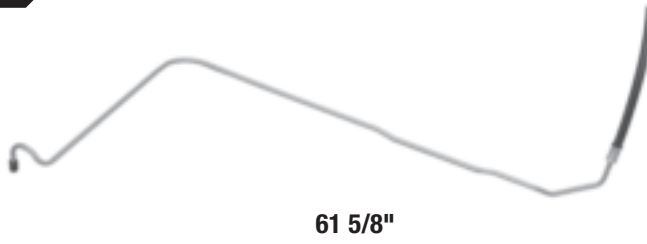

61 5/8"

**B61036**

**OEM# 25533850**

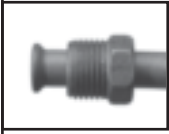

64 3/8"

## 5/16" Male Inv. Flare x 5/16" O.D. Male Beaded Tube

**B61037**

**OEM# 25533258**

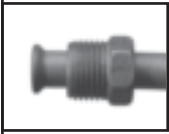

38 3/4"



## 5/16" I.D. Molded Hose x 3/8" I.D. Molded Hose

**B61038**

**OEM# 4546693**



62 7/8"

## 3/8" Male Flared Quick Connect x 3/8" Male Flared Quick Connect

**B61042**

**OEM# 15053195**



52 3/4"



Product Section

Troubleshooting

EOC Applications

TOC Applications

Numerical Listing

Manufacturers' Part Numbers

End Fittings

Illustrations

Product Section

## 3/8" Male Flared Quick Connect x 3/8" Male Flared Quick Connect (continued)

**B61043**

OEM# 15053198

Troubleshooting



EOC Applications

## 3/8" Male Single Beaded Quick Connect x 3/8" Male Double Beaded Quick Connect

**B61046**

OEM# F6DZ 7A030 CA

TOC Applications



Numerical Listing

## 3/8" Male Inv. Flare x 3/8" O.D. Male Double Beaded Tube

**B61047**

OEM# F81Z 7A030 AA

Manufacturers' Part Numbers



End Fittings

## 3/8" Female S.A.E. x 3/8" Female S.A.E.



**B61048**

OEM# 5003714AA



Illustrations

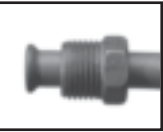



## 1/2" Male Inv. Flare x 1/2" Male Single Beaded Quick Connect

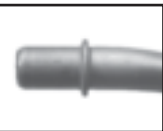

<b>B61050</b>	OEM# 52028673
	
	
56 3/4"	

## 3/8" Male Single Beaded Quick Connect x 3/8" O.D. Male Beaded Tube



<b>B61051</b>	OEM# 52027675
	
	
34 1/4"	

## 3/8" Male Inv. Flare x 3/8" I.D. Hose

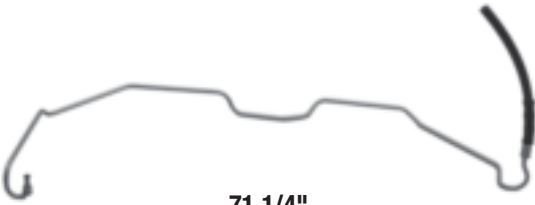
<b>B61053</b>	OEM# 10273348
	
	
52 3/8"	

<b>B61054</b>	OEM# 10273349
	
	
71 1/4"	

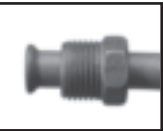
## 3/8" Male Inv. Flare x 3/8" Male Flared Quick Connect

<b>B61055</b>	OEM# 15051890
	
	
65 1/4"	

# ILLUSTRATIONS

## 3/8" Male Inv. Flare x 3/8" Male Flared Quick Connect (continued)

Product Section

Troubleshooting

EOC Applications

TOC Applications

Numerical Listing

Manufacturers' Part Numbers

End Fittings

Illustrations

**B61056**

OEM# 15051892

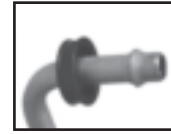
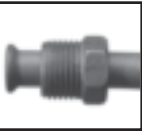

39 3/4"

**B61057**

OEM# 15051898

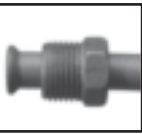

71 3/4"

**B61058**

OEM# 15051900



73 3/4"

**B61059**

OEM# 15723417



81 1/4"

**B61060**

OEM# 15723421



69 1/8"



## 5/16" Male Inv. Flare x 5/16" O.D. Male Double Beaded Tube

**B61064**

OEM# 4644663

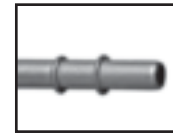
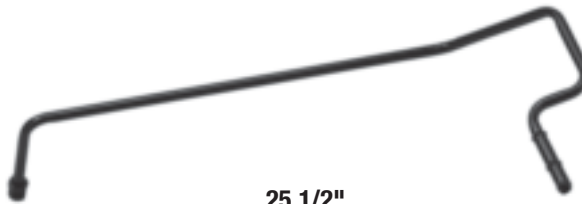
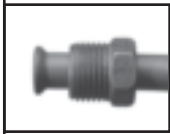

25 1/2"

## 5/16" I.D. Molded Hose x 5/16" O.D. Male Beaded Tube

**B61065**

OEM# 4682741



46 1/4"

## 5/16" I.D. Molded Hose x 5/16" I.D. Molded Hose

**B61066**

OEM# 4682741



43 1/4"

## 3/8" Female Inv. Flare x 3/8" I.D. Molded Hose

**B61067**

OEM# 4698965AD



49 1/2"

**B61068**

OEM# 4698960AD



58 7/8"

Product Section

Troubleshooting

EOC Applications

TOC Applications

Numerical Listing

Manufacturers' Part Numbers

End Fittings

Illustrations

# ILLUSTRATIONS

Product Section

## 3/8" Male O-Ring x 3/8" O.D. Male Beaded Tube

**B61073**

OEM# 4758187

Troubleshooting



33 7/8"

EOC Applications

## 3/8" Long Male Inv. Flare x 3/8" Male Inv. Flare

**B61100**

OEM# YC3Z 7A031 AA

TOC Applications

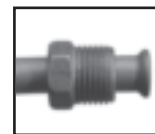

75 1/2"

Numerical Listing

## 3/8" Female Inv. Flare x 3/8" Male Single Beaded Quick Connect

**B61101**

OEM# 4617989

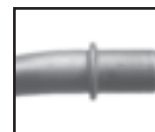

65 1/4"

Manufacturers' Part Numbers

**B61103**

OEM# 52027674

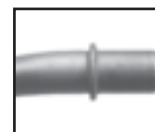

24"

End Fittings

**B61104**

OEM# 4883709AA

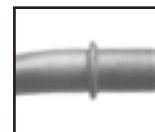

22 1/2"

Illustrations

# ILLUSTRATIONS

## 3/8" Male Inv. Flare x 3/8" Male Inv. Flare

**B61105**

**OEM# 03544702**

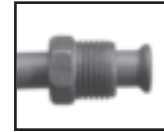
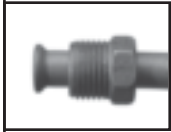

60 3/8"

**B61106**

**OEM# 25658710**

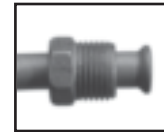

57 1/2"

## 3/8" Male Flared Quick Connect x 3/8" Male Flared Quick Connect

**B61107**

**OEM# 15745473**



81"

**B61108**

**OEM# 15745475**



81 1/2"

## 5/16" Male Inv. Flare x 1/2" Male Flared Quick Connect

**B61109**

**OEM# 15978416**



71 1/4"

Product Section

Troubleshooting

EOC Applications

TOC Applications

Numerical Listing

Manufacturers' Part Numbers

End Fittings

Illustrations

# ILLUSTRATIONS

Product Section

Troubleshooting

EOC Applications

TOC Applications

Numerical Listing

Manufacturers' Part Numbers

End Fittings

Illustrations

## 3/8" Male Inv. Flare x 3/8" O.D. Male Double Beaded Tube

**B61110**

OEM# 25623918

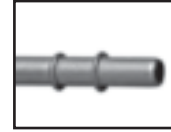
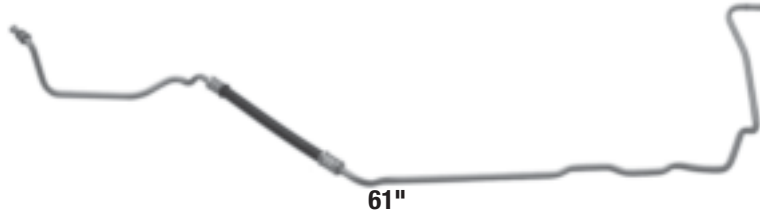

61"

## 3/8" Male Inv. Flare x 3/8" Male Inv. Flare

**B61111**

OEM# 25660782

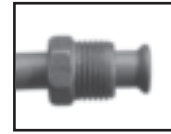
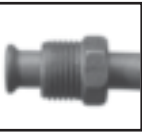

53 3/4"

**B61112**

OEM# 25663931

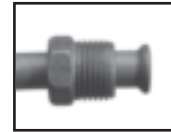
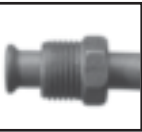

61"

**B61116**

OEM# 4728643

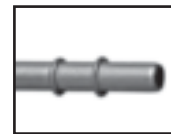
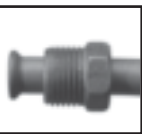

23 5/8"

## 3/8" Female Inv. Flare x 3/8" Male Single Beaded Quick Connect

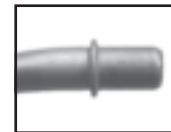

**B61117**

OEM# 52028328





28 1/4"

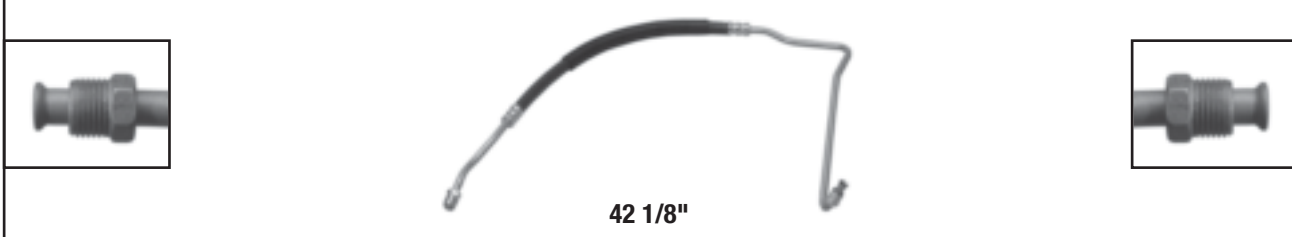

## 3/8" Male Inv. Flare x 3/8" Male Inv. Flare

<b>B61119</b>	<b>OEM# 22651564</b>
	
 <p style="text-align: center;">42 1/8"</p>	

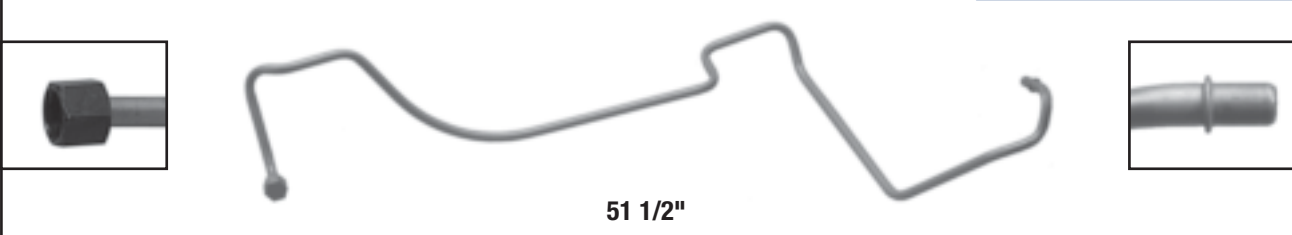
## 3/8" Female Inv. Flare x 3/8" Male Single Beaded Quick Connect

<b>B61120</b>	<b>OEM# 52028504</b>
	
 <p style="text-align: center;">51 1/2"</p>	

## 3/8" Female Quick Connect x 3/8" Male Single Beaded Quick Connect

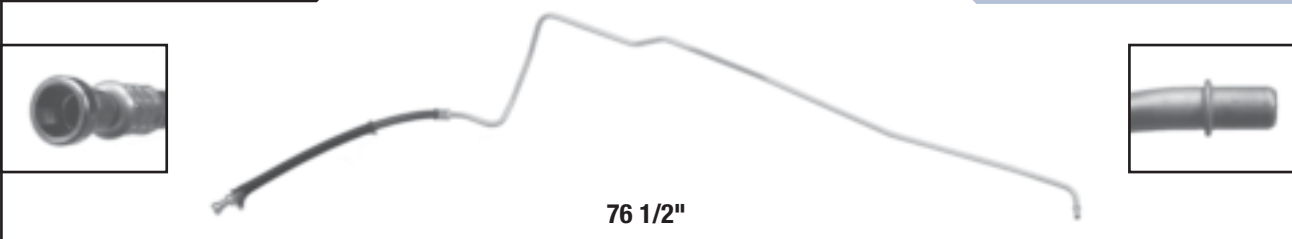
<b>B61122</b>	<b>OEM# 52028566</b>
	
 <p style="text-align: center;">76 1/2"</p>	

## 3/8" Female Inv. Flare x 3/8" Male Single Beaded Quick Connect

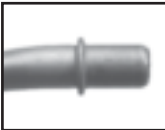
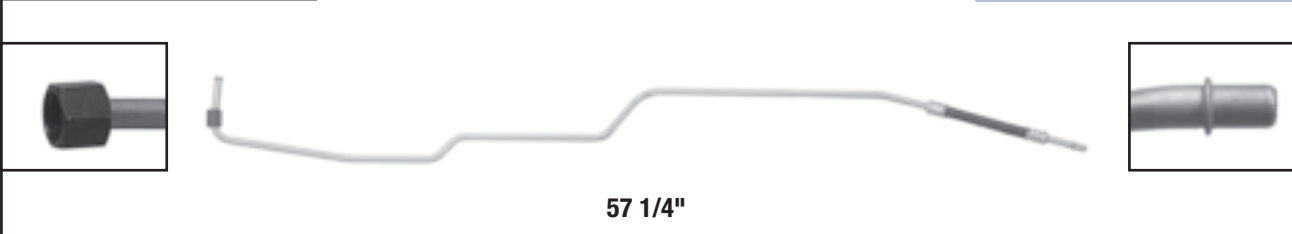
<b>B61123</b>	<b>OEM# 52028662</b>
	
 <p style="text-align: center;">57 1/4"</p>	

Product Section

Troubleshooting

EOC Applications

TOC Applications

Numerical Listing

Manufacturers' Part Numbers

End Fittings

Illustrations

# ILLUSTRATIONS

Product Section

## 3/8" Female Inv. Flare x 3/8" Male Single Beaded Quick Connect (continued)

**B61124**

OEM# 52028761

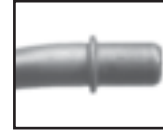

55 3/4"

Troubleshooting

EOC Applications

## 3/8" Female Inv. Flare x 3/8" O.D. Male Beaded Tube

**B61127**

OEM# 52079590

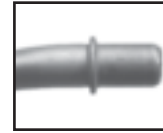

41"

TOC Applications

Numerical Listing

## 1/2" Female Inv. Flare x 1/2" Male Inv. Flare

**B61129**

OEM# 52117602

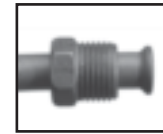
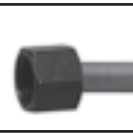

42 3/4"

Manufacturers' Part Numbers

End Fittings

## 3/8" Female Inv. Flare x 3/8" Female Quick Connect

**B61132**

OEM# 4883802AB

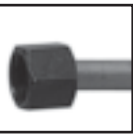

61 3/8"

Illustrations

# ILLUSTRATIONS

## 3/8" Female Inv. Flare x 3/8" Female Quick Connect

**B61133**

OEM# 4883803AB



72 1/2"

## 3/8" Female Inv. Flare x 3/8" Female Inv. Flare

**B61135**

OEM# 4883804AB



51 1/8"

## 3/8" Female Inv. Flare x 3/8" Female Inv. Flare

**B61138**

OEM# 4883806AB



57 1/2"

Product Section

Troubleshooting

EOC Applications

TOC Applications

Numerical Listing

Manufacturers'  
Part Numbers

End Fittings

Illustrations

# ILLUSTRATIONS

Product Section

## 1/2" Female Inv. Flare x 1/2" Male Inv. Flare

**B61141**

OEM# 5011244AA



35 5/8"

Troubleshooting

EOC Applications

## 3/8" Male Inv. Flare x 3/8" Male Inv. Flare

**B61143**

OEM# 03540435



67 1/4"

TOC Applications

Numerical Listing

## 3/8" Male Inv. Flare x 3/8" Male Single Beaded Quick Connect

**B61144**

OEM# 5013845AA

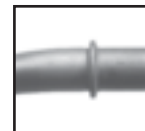
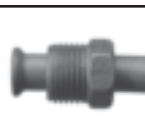

46 1/4"

Manufacturers' Part Numbers

End Fittings

## 3/8" Female Quick Connect x 3/8" Male Single Beaded Quick Connect

**B61146**

OEM# 52028566AD

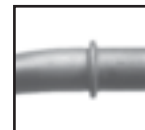

58"

Illustrations



# ILLUSTRATIONS

## 3/8" Female Quick Connect x 3/8" Male Single Beaded Quick Connect (continued)

**B61147**

OEM# 52028605AD



74 1/4"

## 3/8" Female Inv. Flare x 3/8" Female Inv. Flare

**B61148**

OEM# 52028646AG



46 3/8"

**B61151**

OEM# 52028654AF



57 1/2"

## 3/8" Female Inv. Flare x 3/8" Female Quick Connect

**B61153**

OEM# 52028655AF



72 3/8"

**B61154**

OEM# 52028656AF



75 3/4"

Product Section

Troubleshooting

EOC Applications

TOC Applications

Numerical Listing

Manufacturers' Part Numbers

End Fittings

Illustrations

# ILLUSTRATIONS

Product Section

## 3/8" Female Inv. Flare x 3/8" Female Inv. Flare

**B61155**

OEM# 52028670AH

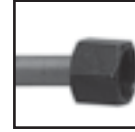

72 3/8"

Troubleshooting

EOC Applications

## 1/2" Female Inv. Flare x 1/2" Male Inv. Flare

**B61157**

OEM# 52028671AD

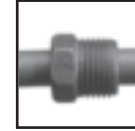

62 3/8"

TOC Applications

Numerical Listing

## 5/16" Male Inv. Flare x 1/2" Male Flared Quick Connect

**B61159**

OEM# 15980548



93 1/2"













Manufacturers' Part Numbers

End Fittings

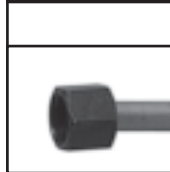

Illustrations

# ILLUSTRATIONS

## 3/8" Female Inv. Flare x 3/8" Female Inv. Flare

<b>B61160</b>		<b>OEM# 52028767AI</b>
		
63 1/2"		
<b>B61161</b>		<b>OEM# 52028753AG 52028753AK</b>
		
51 3/4"		
<b>B61163</b>		<b>OEM# 52028783AF</b>
		
57 7/8"		
<b>B61164</b>		<b>OEM# 52028784AE 52028784AG</b>
		
72 1/4"		

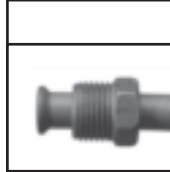
## 5/16" Male Inv. Flare x 1/2" Male Flared Quick Connect

<b>B61165</b>		<b>OEM# 10269708 10270307</b>
		
72 7/8"		

Product Section

Troubleshooting

EOC Applications

TOC Applications

Numerical Listing

Manufacturers'  
Part Numbers

End Fittings

Illustrations

Product Section

## 3/8" Female Inv. Flare x 3/8" Female Inv. Flare

**B61166**

OEM# 52028817AD

Troubleshooting

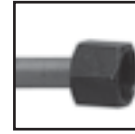
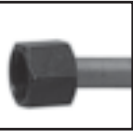

58 3/4"

EOC Applications

## 3/8" Female Inv. Flare x 3/8" Female Quick Connect

**B61167**

OEM# 52028819AD

TOC Applications



74 1/4"

Numerical Listing

**B61168**

OEM# 52028868AE



86"

Manufacturers' Part Numbers

## 5/16" Male Inv. Flare x 1/2" Male Flared Quick Connect

**B61169**

OEM# 15980571

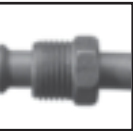

End Fittings





52 1/4"

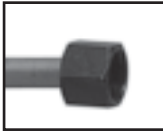

Illustrations

## 3/8" Female Inv. Flare x 3/8" Female Inv. Flare



<b>B61170</b>	OEM# 52028659
	
 <p>46 1/2"</p>	

<b>B61173</b>	OEM# 52079676AB
	
 <p>41 1/2"</p>	



## 3/8" Female Quick Connect x 3/8" Male Single Beaded Quick Connect

<b>B61175</b>	OEM# 52079676AB
	
 <p>64 3/4"</p>	

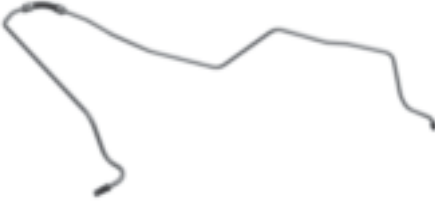
## 5/16" Long Male Inv. Flare x 5/16" Male Inv. Flare

<b>B61176</b>	OEM# E9SZ 7A031 A
	
 <p>68 3/4"</p>	

## 5/16" Long Male Inv. Flare x 5/16" Male Single Bead Quick Connect

<b>B61177</b>	OEM# F0DZ 7A030 D
	
 <p>61 3/4"</p>	

Product Section

Troubleshooting

EOC Applications

TOC Applications

Numerical Listing

Manufacturers' Part Numbers

End Fittings

Illustrations

# ILLUSTRATIONS

Product Section

## 5/16" Long Male Inv. Flare x 5/16" I.D. Hose

**B61178**

OEM# F1DZ 7C410 AA



55 1/2"

Troubleshooting

EOC Applications

## 5/16" I.D. Hose x 5/16" I.D. Hose

**B61179**

OEM# F58Z 7H168 AF



32 3/8"

TOC Applications

## 5/16" Long Male Inv. Flare x 5/16" I.D. Hose

**B61180**

OEM# F58Z 7H168 AF

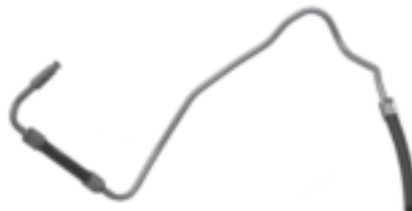

39 1/2"

Numerical Listing

Manufacturers' Part Numbers

## 5/16" I.D. Hose x 5/16" I.D. Hose

**B61181**

OEM# F5VZ 7H168 AF



35 3/4"

End Fittings

Illustrations

## 5/16" Long Male Inv. Flare x 5/16" I.D. Hose

**B61182**

OEM# F5VZ 7H168 AF



42 7/8"

## 3/8" Male Inv. Flare x 3/8" O.D. Male Beaded Tube

**B61183**

OEM# F67Z 7A030 VA



52 1/8"

## 3/8" Long Male Inv. Flare x 3/8" Male Inv. Flare

**B61184**

OEM# F67Z 7A031 UA



86 5/8"

Product Section

Troubleshooting

EOC Applications

TOC Applications

Numerical Listing

Manufacturers'  
Part Numbers

End Fittings

Illustrations

# ILLUSTRATIONS

Product Section

## 5/16" Long Male Inv. Flare x 5/16" Male Inv. Flare

**B61185**

OEM# F6AZ 7A031 AA

Troubleshooting

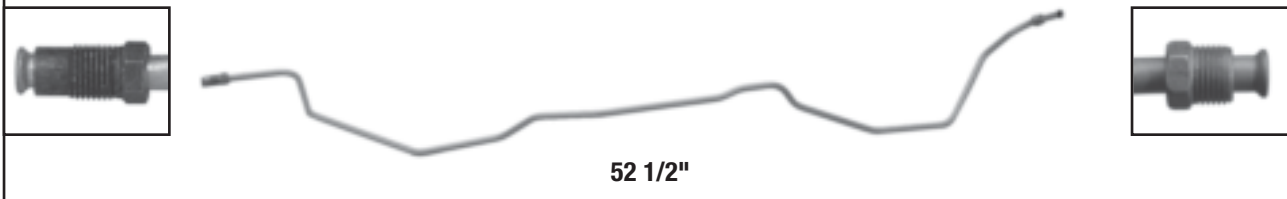

EOC Applications

## 3/8" Long Male Inv. Flare x 3/8" Male Inv. Flare

**B61186**

OEM# F75Z 7A030 AA

TOC Applications



Numerical Listing

## 3/8" Male Inv. Flare x 3/8" I.D. Hose

**B61187**

OEM# F75Z 7A030 GA

Manufacturers' Part Numbers

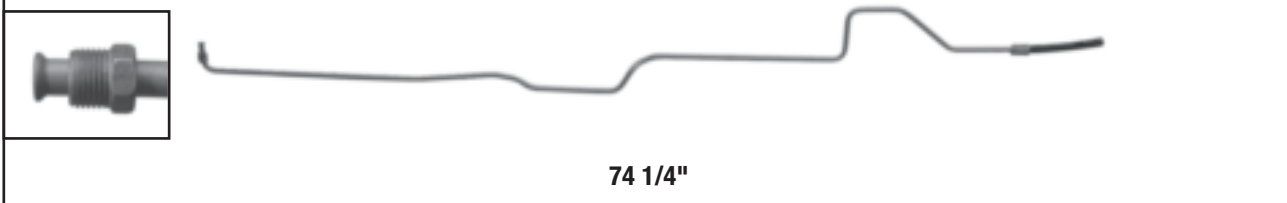

End Fittings

## 5/16" Long Male Inv. Flare x 5/16" Male Inv. Flare

**B61188**

OEM# F75Z 7A030 LA

Illustrations

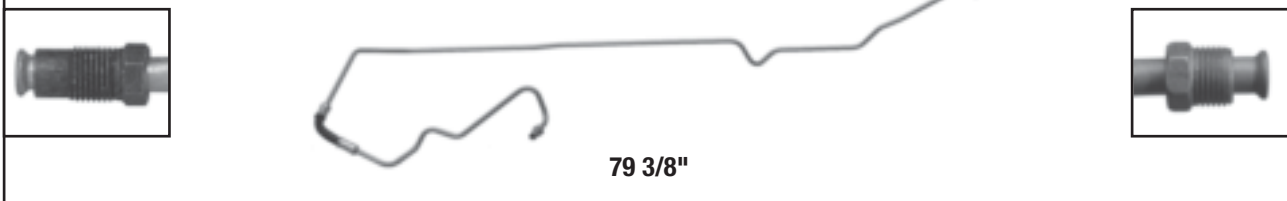



## 5/16" Male Inv. Flare x 5/16" I.D. Hose

**B61189**

OEM# F75Z 7A030 MA

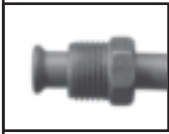

55 1/2"

## 3/8" Long Male Inv. Flare x 3/8" Long Male Inv. Flare

**B61190**

OEM# F75Z 7A031 AA



90 1/4"

## 5/16" Long Male Inv. Flare x 5/16" Male Inv. Flare

**B61191**

OEM# F75Z 7A031 LA



86 5/8"

## 5/16" Long Male Inv. Flare x 5/16" Long Male Inv. Flare

**B61192**

OEM# F75Z 7C410 EA



37 1/2"

Product Section

Troubleshooting

EOC Applications

TOC Applications

Numerical Listing

Manufacturers' Part Numbers

End Fittings

Illustrations

## 3/8" Long Male Inv. Flare x 3/8" Long Male Inv. Flare

**B61193**

OEM# F7TZ 7F113 DD



37 1/2"

## 3/8" Long Male Inv. Flare x 3/8" Male Inv. Flare

**B61194**

OEM# F85Z 7A031 BA

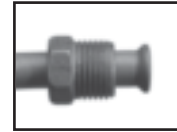
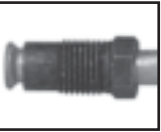

94"

## 3/8" Long Male Inv. Flare x 5/16" Male Inv. Flare

**B61196**

OEM# XL3Z 7A030 AA

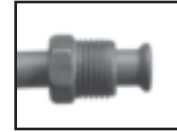

80"

**B61197**

OEM# XL3Z 7A031 AA



87 3/4"

## 3/8" Long Male Inv. Flare x 3/8" Male Inv. Flare

**B61198**



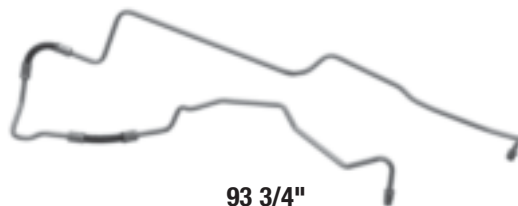















OEM# XL3Z 7A031 BC



93 3/4"

# ILLUSTRATIONS

## 3/8" Female Inv. Flare x 3/8" Female Inv. Flare

<b>B61199</b>	<b>OEM# 52028645AE</b>	
	 <p style="text-align: center;">45 1/8"</p>	
<b>B61200</b>	<b>OEM# 52028782AH</b>	
	 <p style="text-align: center;">52 1/2"</p>	
<b>B61201</b>	<b>OEM# 52028757</b>	
	 <p style="text-align: center;">42 1/4"</p>	
<b>B61202</b>	<b>OEM# 5202872AJ</b>	
	 <p style="text-align: center;">53 1/2"</p>	
<b>B61203</b>	<b>OEM# 52028897AB</b>	
	 <p style="text-align: center;">54 1/2"</p>	
<b>B61204</b>	<b>OEM# 52029303AB 52029303AC</b>	
	 <p style="text-align: center;">70 1/8"</p>	

Product Section

Troubleshooting

EOC Applications

TOC Applications

Numerical Listing

Manufacturers'  
Part Numbers

End Fittings

Illustrations

# ILLUSTRATIONS

Product Section

## 3/8" Female Inv. Flare x 3/8" Female Quick Connect

**B61205**

OEM# 52028785AF



75 1/2"

Troubleshooting

EOC Applications

## 3/8" Female Inv. Flare x 3/8" Female Inv. Flare

**B61207**

OEM# 52079677AB

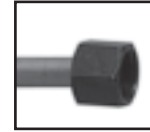

49"

TOC Applications

Numerical Listing

## 3/8" Female Quick Connect x 3/8" Male Single Beaded Quick Connect

**B61208**

OEM# 52028605

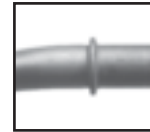

53 3/8"

Manufacturers' Part Numbers

End Fittings

## 3/8" Female Inv. Flare x 3/8" Male Single Beaded Quick Connect

**B61209**



OEM# 52028658AB





52 5/8"

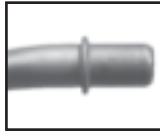

Illustrations

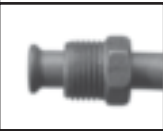
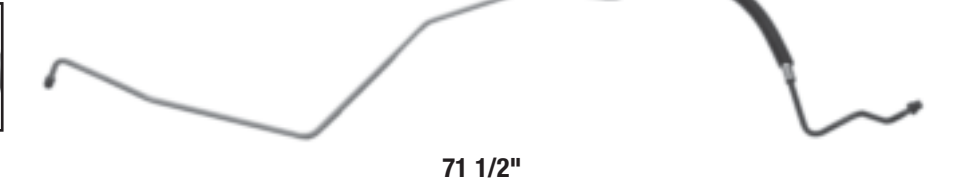

## 3/8" Female Quick Connect x 3/8" Male Single Beaded Quick Connect (continued)



<b>B61210</b>	OEM# 52079692AB	
	 <p style="text-align: center;">77"</p>	

## 5/16" Male Inv. Flare x 1/2" Male Flared Quick Connect

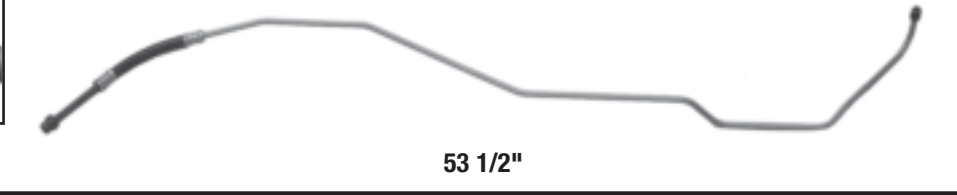
<b>B61211</b>	OEM# 15982923	
	 <p style="text-align: center;">71 1/2"</p>	

<b>B61212</b>	OEM# 15983143	
	 <p style="text-align: center;">72 1/2"</p>	

<b>B61214</b>	OEM# 15986637	
	 <p style="text-align: center;">53 1/2"</p>	

<b>B61215</b>	OEM# 15986641	
	 <p style="text-align: center;">34 1/4"</p>	

Product Section

Troubleshooting

EOC Applications

TOC Applications

Numerical Listing

Manufacturers' Part Numbers

End Fittings

Illustrations

Product Section

## 5/16" Male Inv. Flare x 1/2" Male Flared Quick Connect (continued)

**B61216**

OEM# 15988860



51 1/2"

Troubleshooting

**B61218**

OEM# 15990594

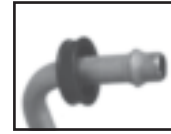
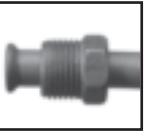

54"

EOC Applications

TOC Applications

## 5/16" Male Inv. Flare x 3/8" Male Inv. Flare

**B61232**

OEM# 22645906

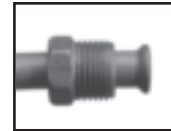

58 3/4"

Numerical Listing

**B61233**

OEM# 22645907



50 3/8"

Manufacturers' Part Numbers

End Fittings

## 5/16" Long Male Inv. Flare x 5/16" Male Inv. Flare

**B61234**



OEM# FOSZ 7A030 A





78 1/4"

Illustrations



## 5/16" Male Inv. Flare x 1/2" Male Flared Quick Connect



<b>B61235</b>	<b>OEM# 15980550</b>
	
 <p>72 1/2"</p>	



## 3/8" Male Inv. Flare x 3/8" O.D. Male Beaded Tube

<b>B61237</b>	<b>OEM# 10254586</b>
	
 <p>26 3/4"</p>	

## 3/8" Male Inv. Flare x 3/8" Male Flared Quick Connect

<b>B61238</b>	<b>OEM# 10409060</b>
	
 <p>47 5/8"</p>	

<b>B61239</b>	<b>OEM# 10415914</b>
	
 <p>53 1/2"</p>	

<b>B61240</b>	<b>OEM# 15996169</b>
	
 <p>38 1/2"</p>	

Product Section

Troubleshooting

EOC Applications

TOC Applications

Numerical Listing

Manufacturers' Part Numbers

End Fittings

Illustrations

Product Section

## 3/8" Male Inv. Flare x 3/8" Male Inv. Flare

**B61241**

OEM# 25624177

Troubleshooting



62 5/8"

EOC Applications

## 3/8" Male Inv. Flare x 3/8" I.D. Hose

**B61242**

OEM# 25606750

TOC Applications

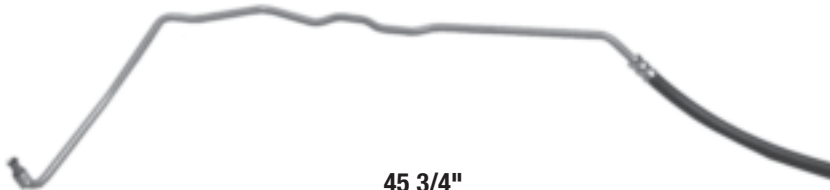

45 3/4"

Numerical Listing

## 3/8" Male Inv. Flare x 3/8" O.D. Male Beaded Tube

**B61244**

OEM# 25615305

Manufacturers' Part Numbers

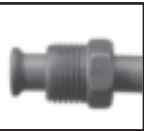

26"

End Fittings

## 3/8" I.D. Hose x 3/8" O.D. Male Beaded Tube

**B61245**

OEM# 25606751

Illustrations





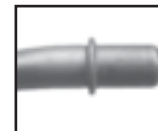















44 1/2"





# ILLUSTRATIONS

## 3/8" Male Flared Quick Connect x 3/8" Male Flared Quick Connect

<b>B61250</b>		<b>OEM# 15053317</b>
		
55 1/2"		
<b>B61251</b>		<b>OEM# 15053318</b>
		
63 1/4"		
<b>B61252</b>		<b>OEM# 15995067</b>
		
69 3/4"		
<b>B61253</b>		<b>OEM# 15995058</b>
		
73 3/8"		
<b>B61254</b>		<b>OEM# 15995056</b>
		
93 5/8"		
<b>B61255</b>		<b>OEM# 52028563</b>
		
77"		

Product Section

Troubleshooting

EOC Applications

TOC Applications

Numerical Listing

Manufacturers' Part Numbers

End Fittings

Illustrations

# ILLUSTRATIONS

Product Section

Troubleshooting

EOC Applications

TOC Applications

Numerical Listing

Manufacturers' Part Numbers

End Fittings

Illustrations

## 3/8" Male Single Beaded Quick Connect x 3/8" Male Single Beaded Quick Connect

**B61257**

OEM# 52079387

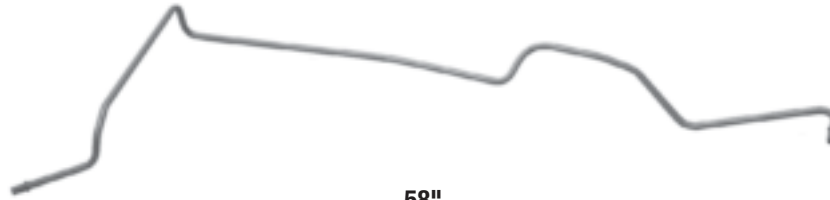
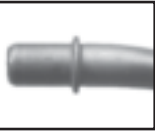

58"



**B61258**

OEM# 4617992

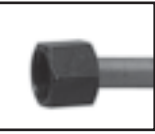

38 3/4"

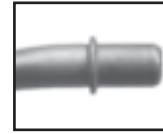

## 3/8" Male Flared Quick Connect x 3/8" Male Flared Quick Connect

**B61259**

OEM# 15052170



64"



**B61260**

OEM# 15052177

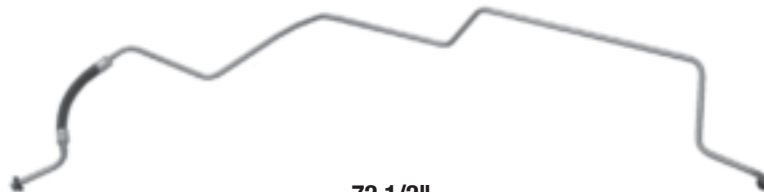

72 1/2"



**B61261**

OEM# 15052182













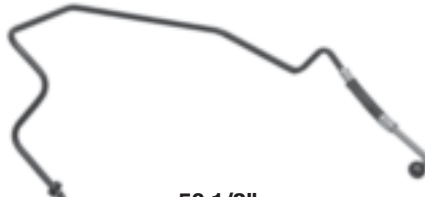



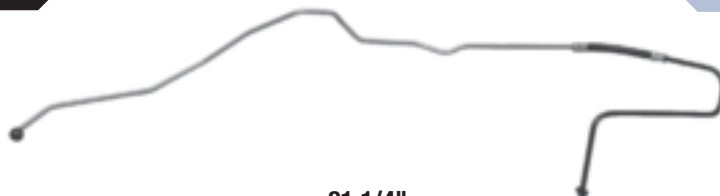

116 1/4"

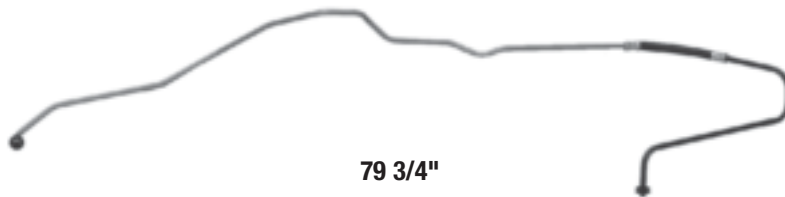

# ILLUSTRATIONS

## 3/8" Male Flared Quick Connect x 3/8" Male Flared Quick Connect (continued)

<b>B61262</b>	 <p>71 3/4"</p>	<b>OEM# 15052879</b>
		
<b>B61263</b>	 <p>50 1/2"</p>	<b>OEM# 15052881</b>
		
<b>B61264</b>	 <p>46"</p>	<b>OEM# 15052883</b>
		
<b>B61265</b>	 <p>81 1/4"</p>	<b>OEM# 15052884</b>
		
<b>B61266</b>	 <p>79 3/4"</p>	<b>OEM# 15052885</b>
		
<b>B61267</b>	 <p>77 1/4"</p>	<b>OEM# 15052886</b>
		

Product Section

Troubleshooting

EOC Applications

TOC Applications

Numerical Listing

Manufacturers' Part Numbers

End Fittings

Illustrations

# ILLUSTRATIONS

## 3/8" Male Flared Quick Connect x 3/8" Male Flared Quick Connect (continued)

**B61268**

OEM# 15714053



61 3/8"

**B61269**

OEM# 15027494



66 3/4"

**B61270**

OEM# 15765447



67 1/4"

## 3/8" Male Inv. Flare x 3/8" Male Inverted Flare

**B61272**

OEM# 6300064



Outlet Hose 42 3/4"

**B61273**

OEM# 6300065



Inlet Hose 54 1/8"

Product Section

Troubleshooting

EOC Applications

TOC Applications

Numerical Listing

Manufacturers' Part Numbers

End Fittings

Illustrations

## 3/8" Male Inv. Flare x 3/8" Male Inverted Flare (continued)

**B61275** **OEM# 6300065**

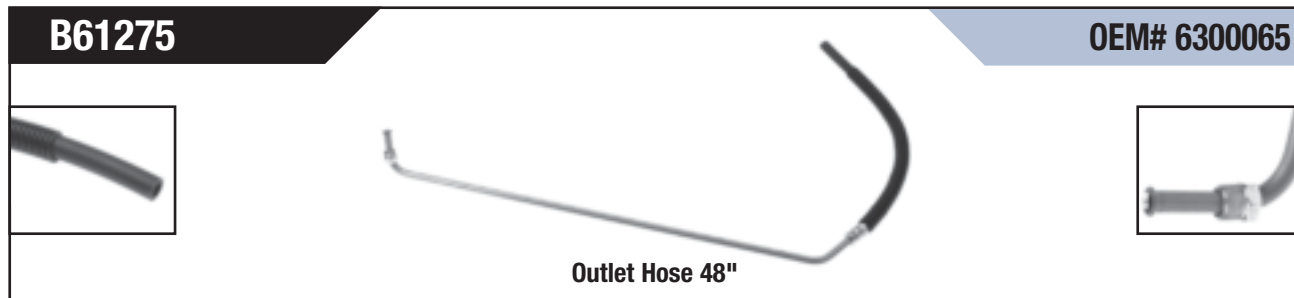

Outlet Hose 48"

## 3/8" Long Male Inv. Flare x 3/8" Male Inv. Flare

**B61277** **OEM# F87Z 7A030 KA**

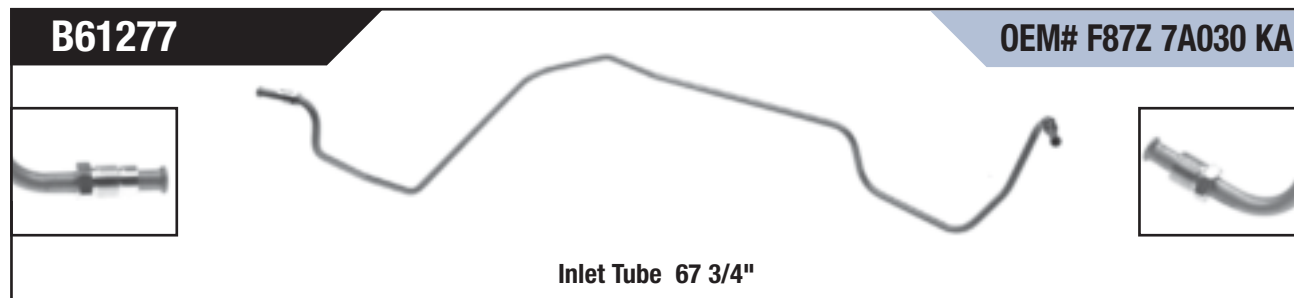

Inlet Tube 67 3/4"

## 3/8" Male Inv. Flare x 3/8" Double Beaded Tube

**B61278** **OEM# F87Z 7A030 LA**

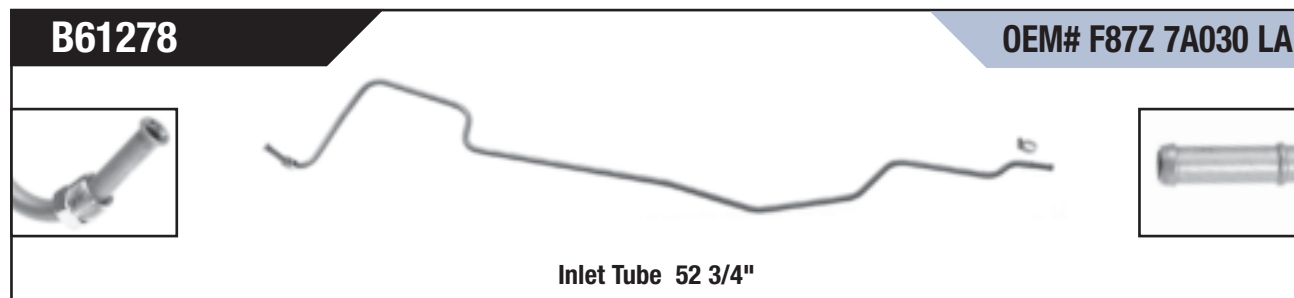

Inlet Tube 52 3/4"

## 3/8" Long Male Inv. Flare x 3/8" Double Beaded Tube

**B61279** **OEM# F87Z 7C410 LA**

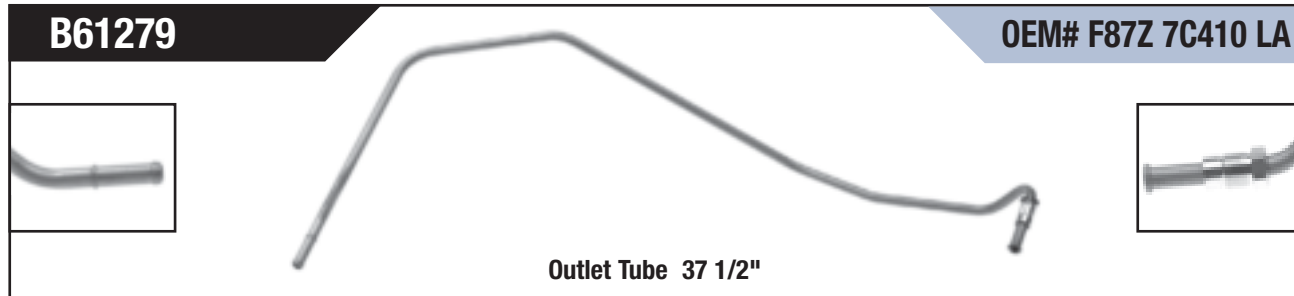

Outlet Tube 37 1/2"

Product Section

Troubleshooting

EOC Applications

TOC Applications

Numerical Listing

Manufacturers'  
Part Numbers

End Fittings

Illustrations

# ILLUSTRATIONS

Product Section

## 3/8" Long Male Inv. Flare x 3/8" Male Inv. Flare

**B61280**

OEM# F87Z 7A031 KA

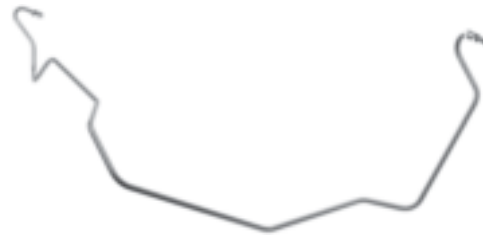

Outlet Tube 80 1/2"

Troubleshooting

**B61281**

OEM# F87Z 7A031 UA



Outlet Tube 86 1/4"

EOC Applications

**B61282**

OEM# YL3Z 7A031 BC



Outlet Tube 93"

TOC Applications

Numerical Listing

## 3/8" Male Inv. Flare x 3/8" Double Beaded Tube

**B61283**

OEM# F81Z 7A030 CA



Inlet Tube 59 1/8"

Manufacturers' Part Numbers

**B61284**

OEM# F81Z 7A031 CE



Outlet Tube 49 3/8"

End Fittings

Illustrations

## 3/8" Long Male Inv. Flare x 3/8" Male Inv. Flare

**B61285**

OEM# YC3Z 7A031 CA



Outlet Hose 81 3/4"

## 3/8" Male Inv. Flare x 3/8" Double Beaded Tube

**B61286**

OEM# F87Z 7A030 JA



Inlet Hose 53 1/4"

## 3/8" Long Male Inv. Flare x 3/8" Male Inv. Flare

**B61287**

OEM# F87Z 7A031 HA



Outlet Tube 76 1/4"

## 3/8" Male Inv. Flare x 3/8" Double Beaded Tube

**B61288**

OEM# F87Z 7A030 VA

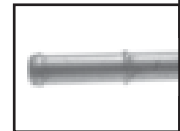

Inlet Tube 54 1/4"

Product Section

Troubleshooting

EOC Applications

TOC Applications

Numerical Listing

Manufacturers'  
Part Numbers

End Fittings

Illustrations

# ILLUSTRATIONS

Product Section

## 3/8" Long Male Inv. Flare x 3/8" Double Beaded Tube

**B61289**

OEM# F87Z 7C410 VA

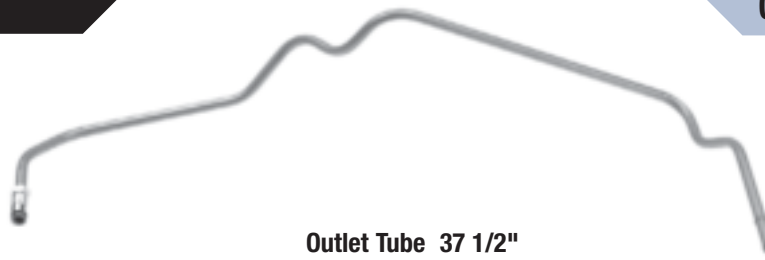

Outlet Tube 37 1/2"

Troubleshooting

EOC Applications

## 3/8" Long Male Inv. Flare x 3/8" Double Beaded Tube

**B61290**

OEM# F87Z 7A031 FA



Outlet Tube 66 1/8"

TOC Applications

Numerical Listing

## 3/8" Long Male Inv. Flare x 3/8" Male Inv. Flare

**B61291**

OEM# F87Z 7A030 FA



Inlet Tube 54 3/4"

Manufacturers' Part Numbers

## 3/8" Male Flared Quick Connect x 3/8" Male Flared Quick Connect

**B61292**

OEM# 25742502  
R/B 15233586

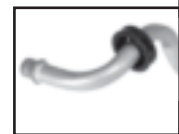



Outlet Hose 45 3/4"

End Fittings



Illustrations





## 3/8" Male Flared Quick Connect x 3/8" Male Flared Quick Connect (continued)

<b>B61293</b>			
Inlet Hose 55 3/8"			
		OEM# 25663925 R/B 15233587	



## 5/16" Male Inv. Flare x 3/8" Male Flared Quick Connect

<b>B61294</b>			
Outlet Hose 75 1/2"			
		OEM# 10271560	

## 5/16" Double Beaded Tube x 3/8" Male Flared Quick Connect

<b>B61295</b>			
Inlet Hose 69 1/4"			
		OEM# 10271556	

## 5/16" Male Inv. Flare x 3/8" Male Flared Quick Connect

<b>B61296</b>			
Outlet Hose 58 3/4"			
		OEM# 10278608	

Product Section

Troubleshooting

EOC Applications

TOC Applications

Numerical Listing

Manufacturers' Part Numbers

End Fittings

Illustrations

# ILLUSTRATIONS

Product Section

## 5/16" Double Beaded Tube x 3/8" Male Flared Quick Connect

**B61297**

OEM# 10278606

Troubleshooting

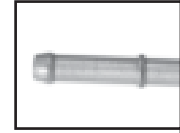
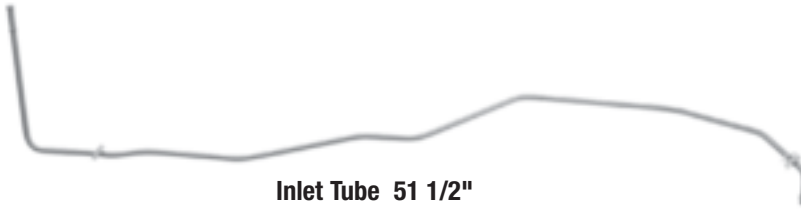

Inlet Tube 51 1/2"

EOC Applications

## 3/8" Long Male Inv. Flare x 3/8" Male Inv. Flare

**B61305**

OEM# F81Z 7A031 FA

TOC Applications

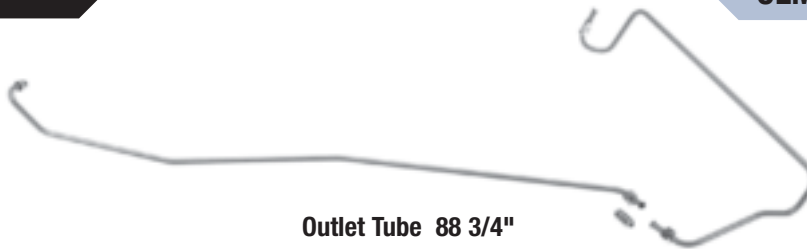

Outlet Tube 88 3/4"

Numerical Listing

## 3/8" Male Inv. Flare x 3/8" Double Beaded Tube

**B61306**

OEM# F7UZ 7A030 BA

Manufacturers' Part Numbers



Inlet Tube 55 5/8"

End Fittings

## 5/16" Male Inv. Flare x 5/16" Double Beaded Tube

**B61307**

OEM# F7UZ 7A030 JA

Illustrations



Inlet Tube 40 5/8"

# ILLUSTRATIONS

## 5/16" Male Inv. Flare x 5/16" Double Beaded Tube (continued)

**B61308**

OEM# F7UZ 7A030 HA



Inlet Tube 41 7/8"

## 5/16" Male Inv. Flare x 5/16" I.D. Hose

**B61309**

OEM# 4C2Z 7A031 JC



Outlet Hose 47"

## 3/8" Long Male Inv. Flare x 3/8" I.D. Hose

**B61310**

OEM# 1C2Z 7A031 BA



Outlet Hose 50 1/2"

## 3/8" Male Flared Quick Connect x 3/8" Male Flared Quick Connect

**B61311**

OEM# 15052176



Inlet Hose 68 1/4"

Product Section

Troubleshooting

EOC Applications

TOC Applications

Numerical Listing

Manufacturers' Part Numbers

End Fittings

Illustrations

# ILLUSTRATIONS

Product Section

## 3/8" Male Flared Quick Connect x 3/8" Male Flared Quick Connect (continued)

Troubleshooting

**B61312**

OEM# 15765052  
R/B 15190205

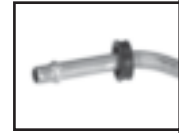

Outlet Hose 69 1/4"

EOC Applications

**B61313**

OEM# 15765054  
R/B 15190202



Outlet Hose 89 3/4"

TOC Applications

Numerical Listing

## 20mm Male O-Ring x 20mm Male O-Ring

**B64200**

OEM# 12472221



Inlet Hose 44 3/8"

Manufacturers' Part Numbers

**B64201**

OEM# 12472222



Outlet Hose 34 1/4"

End Fittings

Illustrations

## 20mm Male O-Ring x 20mm Male O-Ring (continued)

**B64202**

OEM# 12472304

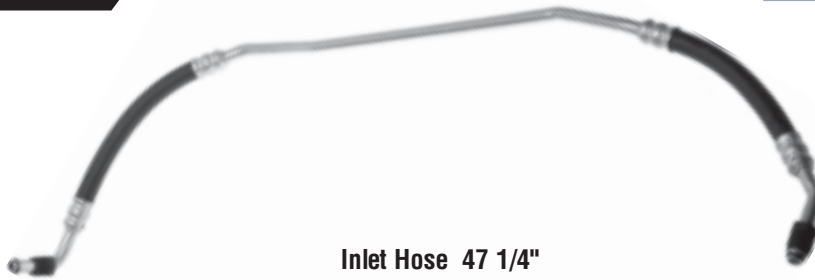

Inlet Hose 47 1/4"

**B64203**

OEM# 12472305



Outlet Hose 54 1/2"

**B64204**

OEM# 15953702



Inlet Hose 64 1/2"

**B64205**

OEM# 15953703



Outlet Hose 51 1/2"

Product Section

Troubleshooting

EOC Applications

TOC Applications

Numerical Listing

Manufacturers'  
Part Numbers

End Fittings

Illustrations

Product Section

Troubleshooting

EOC Applications

TOC Applications

Numerical Listing

Manufacturers' Part Numbers

End Fittings

Illustrations

## 3/4" Female O-Ring x 20mm Male O-Ring

**B64206**

OEM# 12472219



Inlet Hose 62"

**B64207**

OEM# 12472220



Outlet Hose 56 1/8"

## 1/2" Male Single Beaded Quick Connect x 20mm Male O-Ring

**B64208**

OEM# 12472277



Inlet Hose 51 7/8"

**B64209**

OEM# 12472278



Outlet Hose 45 1/2"

## 1/2" Male Flared Quick Connect x 20mm Male O-Ring

**B64210**

OEM# 15112870



Inlet Hose 45 1/2"

**B64211**

OEM# 15112871



Outlet Hose 52 1/2"

## 1/2" 90° Male Flared Quick Connect x 20mm Male O-Ring

**B64212**

OEM# 12472281



Inlet Hose 47 5/8"

## 1/2" 90° Male Flared Quick Connect x 3/4" Male O-Ring

**B64213**

OEM# 12472282



Outlet Hose 52 3/4"

## 1/2" 90° Male Flared Quick Connect x 20mm Male O-Ring

**B64214**

OEM# 12472312



Inlet Hose 55 1/2"

Product Section

Troubleshooting

EOC Applications

TOC Applications

Numerical Listing

Manufacturers'  
Part Numbers

End Fittings

Illustrations

Product Section

Troubleshooting

EOC Applications

TOC Applications

Numerical Listing

Manufacturers' Part Numbers

End Fittings

Illustrations

## 1/2" 90° Male Flared Quick Connect x 3/4" Male O-Ring

**B64215**

OEM# 12472314



Outlet Hose 60"

## 1/2" Male Single Beaded Quick Connect x 3/4" Male O-Ring

**B64216**

OEM# 12472293



Inlet Hose 46 7/8"

**B64217**

OEM# 12472283



Inlet Hose 44 7/8"

## 1/2" Male Single Beaded Quick Connect x 20mm Male O-Ring

**B64218**

OEM# 12472285



Inlet Hose 48 1/2"



## Block Fitting x Block Fitting

**B64219**

**OEM# 12472311**



Inlet & Outlet Assembly 46 1/4"

**B64220**

**OEM# 15194579**



Inlet & Outlet Assembly 27 3/4"

**B64221**

**OEM# 15982251**



Inlet & Outlet Assembly 31"

## Block Fitting x 1/2" Male Flared Quick Connects

**B64222**

**OEM# 15764375**



Inlet & Outlet Assembly 53 1/2"

## Block Fitting x 20mm Male O-Rings

**B64223**

**OEM# 15982250**



Inlet & Outlet Assembly 42 1/2"

Product Section

Troubleshooting

EOC Applications

TOC Applications

Numerical Listing

Manufacturers' Part Numbers

End Fittings

Illustrations

## Block Fitting x 1/2" Male Flared Quick Connect

**B64224**

OEM# 15194577

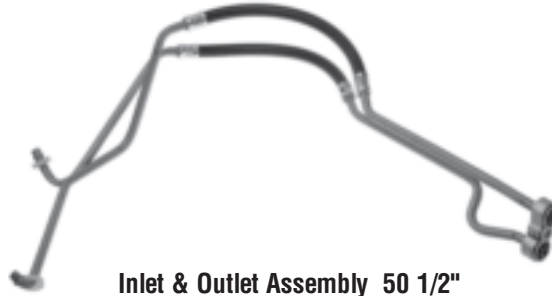

Inlet & Outlet Assembly 50 1/2"

**B64225**

OEM# 15194578



Inlet & Outlet Assembly 40 1/4"

## 1/2" Male Single Beaded Quick Connect x 20mm Male O-Ring

**B64226**

OEM# 12472294



Outlet Hose 50 5/8"

**B64227**

OEM# 12472284



Outlet Hose 49 1/4"

**B64228**

OEM# 12472286



Outlet Hose 44"

## 1/2" Male Flared Quick Connect x 20mm Male O-Ring

**B64229**

OEM# 15985759



Inlet Hose 46 7/8"

**B64230**

OEM# 15985760



Outlet Hose 53 1/4"

**B64231**

OEM# 15112872



Inlet Hose 48 7/8"

**B64232**

OEM# 15112873



Outlet Hose 53"

## 1/2" Male Flared Quick Connect x 1/2" Male Flared Quick Connect

**B64233**

OEM# 15074199



Inlet Hose 49 7/8"

Product Section

Troubleshooting

EOC Applications

TOC Applications

Numerical Listing

Manufacturers' Part Numbers

End Fittings

Illustrations

Product Section

## 1/2" Male Flared Quick Connect x 1/2" Male Flared Quick Connect (continued)

Troubleshooting

**B64234**

OEM# 15074201



Outlet Hose 43"

EOC Applications

## 20mm Male O-Ring x 20mm Male O-Ring

TOC Applications

**B64235**

OEM# 12472217



Inlet Hose 51"

Numerical Listing

**B64236**

OEM# 12472218



Outlet Hose 41 1/8"

Manufacturers' Part Numbers

**B64237**

OEM# 12472260



Inlet Hose 47 7/8"

End Fittings

**B64238**

OEM# 12472261



Illustrations

## 20mm Male O-Ring x 20mm Male O-Ring (continued)

**B64239**

OEM# 12472299



Outlet Hose 53 1/4"

**B64240**

OEM# 12472320



Inlet Hose 61 7/8"

**B64241**

OEM# 12472316



Inlet Hose 45"

**B64242**

OEM# 12472318



Outlet Hose 35 1/2"

## 3/4" Female O-Ring x 20mm Male O-Ring

**B64243**

OEM# 12472195



Inlet Hose 43 5/8"

Product Section

Troubleshooting

EOC Applications

TOC Applications

Numerical Listing

Manufacturers'  
Part Numbers

End Fittings

Illustrations

Product Section

Troubleshooting

EOC Applications

TOC Applications

Numerical Listing

Manufacturers' Part Numbers

End Fittings

Illustrations

## 3/4" Female O-Ring x 20mm Male O-Ring (continued)

**B64244**

OEM# 12472196



Outlet Hose 43 3/4"

## 1/2" Male Single Beaded Quick Connect x 20mm Male O-Ring

**B64245**

OEM# 12472279



Inlet Hose 45 7/8"

**B64246**

OEM# 12472280



Outlet Hose 52 7/8"

**B64247**

OEM# 12472295



Inlet Hose 49 1/4"

**B64248**

OEM# 12472296



Outlet Hose 46 1/4"

## 1/2" Male Flared Quick Connect x 20mm Male O-Ring

**B64249**

OEM# 15738129



Inlet Hose 46"

**B64250**

OEM# 15738138



Outlet Hose 42 3/8"

## 90° Male Flared Quick Connect x 20mm Male O-Ring

**B64251**

OEM# 12472263



Inlet Hose 70 1/4"

**B64252**

OEM# 12472265



Outlet Hose 73 3/4"

**B64253**

OEM# 12472290



Inlet Hose 72 5/8"

Product Section

Troubleshooting

EOC Applications

TOC Applications

Numerical Listing

Manufacturers'  
Part Numbers

End Fittings

Illustrations

## 90° Male Flared Quick Connect x 20mm Male O-Ring (continued)

Product Section

Troubleshooting

EOC Applications

TOC Applications

Numerical Listing

Manufacturers' Part Numbers

End Fittings

Illustrations

**B64254**

OEM# 12472289



Inlet Hose 49 7/8"

**B64255**

OEM# 12472264



Outlet Hose 49 3/4"

**B64256**

OEM# 12472287



Inlet Hose 49"

**B64257**

OEM# 12472288



Outlet Hose 47 3/4"

**B64258**

OEM# 12472313



Inlet Hose 56 5/8"



## 90° Male Flared Quick Connect x 20mm Male O-Ring (continued)

**B64259**

OEM# 12472315



Outlet Hose 60 1/2"

## Block Fitting x 20mm Male O-Ring

**B64260**

OEM# 12472306



Inlet & Outlet Assembly 30 5/8"

**B64261**

OEM# 12472307



Inlet & Outlet Assembly 32 5/8"

## Block Fitting x 1/2" Male Flared Quick Connect

**B64262**

OEM# 15074204



Inlet & Outlet Assembly 52 7/8"

## 20mm Male O-Ring x 20mm Male O-Ring

**B64263**

OEM# 12472308



Inlet Hose 45 5/8"

Product Section

Troubleshooting

EOC Applications

TOC Applications

Numerical Listing

Manufacturers'  
Part Numbers

End Fittings

Illustrations

Product Section

Troubleshooting

EOC Applications

TOC Applications

Numerical Listing

Manufacturers' Part Numbers

End Fittings

Illustrations

## 20mm Male O-Ring x 20mm Male O-Ring (continued)

**B64264**

OEM# 12472309



Outlet Hose 44 3/8"

## 3/4" Female O-Ring x 20mm Male O-Ring

**B64265**

OEM# 12472193



Inlet Hose 47 1/2"

**B64266**

OEM# 12472194



Outlet Hose 47 3/4"

## 1/2" Male Single Beaded Quick Connect x 20mm Male O-Ring

**B64267**

OEM# 12472225



Inlet Hose 54 5/8"

**B64268**

OEM# 12472226



Outlet Hose 44 1/2"

## 1/2" Male Single Beaded Quick Connect x 20mm Male O-Ring (continued)

**B64269**

**OEM# 12472234**



Inlet Hose 47 5/8"

**B64270**

**OEM# 12472230**



Outlet Hose 46 7/8"

**B64271**

**OEM# 12472302**



Inlet Hose 48 1/4"

**B64272**

**OEM# 12472303**



Outlet Hose 44 3/4"

**B64273**

**OEM# 12472212**



Outlet Hose 51 5/8"

Product Section

Troubleshooting

EOC Applications

TOC Applications

Numerical Listing

Manufacturers' Part Numbers

End Fittings

Illustrations

# ILLUSTRATIONS

Product Section

Troubleshooting

EOC Applications

TOC Applications

Numerical Listing

Manufacturers' Part Numbers

End Fittings

Illustrations

## 1/2" Male Flared Quick Connect x 20mm Male O-Ring

**B64274**

OEM# 15127518



Outlet Hose 49 3/4"

## 3/4" Fixed Male x 20mm Male O-Ring

**B64275**

OEM# 12472258



Inlet Hose 28"

**B64276**

OEM# 12472259



Outlet Hose 27 3/4"

## 1/2" Female O-Ring x 3/4" Fixed Male

**B64277**

OEM# 12472199



Inlet Hose 44 5/8"

**B64278**

OEM# 12472200



Outlet Hose 43"













# NOTES

Product Section

Troubleshooting

EOC Applications

TOC Applications

Numerical Listing

Manufacturers'  
Part Numbers

End Fittings

Illustrations

# Tomkins

Industrial and Automotive

---

**Amflo**®

**EDELMANN**®

**IDEAL**™

**PLEWS**™  
**LubriMatic**

  
**SCHRADERBRIDGEPORT**®

**Stant**®

**TRICO**®

**TRIDON**▶▶®

**TRU-FLATE**®

## **Amflo:**

Air Line Accessories  
Pneumatic Hoses

## **Edelmann:**

Power Steering Hose Assemblies  
Automotive Fittings  
Brake Lines  
Transmission Oil Cooler Lines & Fittings  
Engine Oil Cooler Lines  
Unicoil™ Hose Benders

## **Ideal:**

Hose Clamps  
T-Bolts

## **Plews/LubriMatic:**

Oils, Greases & Spray Lubricants  
Lubrication Equipment

## **Schrader-Bridgeport:**

Air Compressors & Pressure Washers  
Tire Valves (Passenger & Truck)  
Tire Pressure Monitoring Systems

## **Stant:**

Fuel, Radiator & Oil Filler Caps  
Thermostats  
Cooling & Fuel Cap Testers

## **Trico:**

Windshield Wiper Products

## **Tridon:**

Windshield Wiper Products  
Hose Clamps  
Flashers

## **Tru-Flate:**

Air Line Accessories  
Tire Gauges & Hardware  
Camel® Tire Hardware & Repair

# EDELMANN®

Telephone ..... (800) 770-4639

Fax ..... (815) 288-3388

Website URL ..... [www.plews-edelmann.com](http://www.plews-edelmann.com)

Route 38, Airport Industrial Park  
Dixon, IL 61021