



# Hager Door Hardware Catalog #28

139 Victor Street  
St. Louis, MO 63104

800-325-9995 (main phone)  
314-772-4400 (local phone)  
800-782-0149 (main fax)  
314-772-0744 (local fax)

[www.hagerco.com](http://www.hagerco.com)  
[webmaster@hagerco.com](mailto:webmaster@hagerco.com)

One Family. One Brand. One Vision.™



© 2016 Hager Companies  
5-500-6510



# General Information



## WELCOME

Hager Companies provides single-source solutions for the door hardware industry with a line of quality products that includes:

- Architectural Hinges
- Residential Hinges
- Roton Continuous Geared Hinges
- Stainless Steel Continuous Hinges
- Trim & Auxiliary
- Thresholds & Weatherstripping
- Sliding Door Hardware
- Locks
- Door Closers
- Exit Devices

Since 1849, Hager's focus has been innovative products, exceptional value, and incomparable customer service. Additionally, Hager offers complimentary comprehensive consulting services. Our services include design development assistance, budget preparation, door hardware specification writing, code compliance, submitted schedules review and approval, and technical project support.

We believe that by offering these value-added services, along with our premium quality, value-priced products, you'll see for yourself how Hager gives you "more for your door than any other brand."

So whatever you're looking for—from simple everyday needs to solutions for unconventional applications—you'll find it in our 2016 Catalog.

## CONTACT INFORMATION

### Corporate Office

139 Victor Street  
St. Louis, Missouri 63104  
800-325-9995 (Sales and Service)  
800-255-3590 (Main Office)  
314-772-4400 (Local Main Office)  
800-782-0149 (Fax)  
314-772-0744 (Local Fax)  
webmaster@hagerco.com  
www.hagerco.com

### Montgomery Plant

150 Folmar Parkway  
Montgomery, AL 36105  
334-284-4700 (Main Phone)

### Montgomery Distribution Center

200 County Court  
Montgomery, AL 36105  
334-288-0432 (Main Phone)

### Southwest Office

12440 Firestone Blvd. #310  
Norwalk, CA 90650  
855-557-0010 (Main Phone)

### Canadian Office

P.O. Box 124  
Kitchener, Ontario  
Canada N2C 1J1



## GENERAL INFORMATION

### TERMINOLOGY

Terminology used in this catalog complies with the following ANSI/BHMA standards:

- ANSI A156.1 - Butts and Hinges
- ANSI A156.2 - Bored and Presassembled Locks and Latches
- ANSI A156.3 - Exit Devices
- ANSI A156.4 - Door Controls-Closers
- ANSI A156.5 - Auxiliary Locks and Associated Products
- ANSI A156.6 - Architectural Door Trim
- ANSI A156.7 - Template Hinge Dimensions
- ANSI A156.8 - Door Controls-Overhead Stops and Holders
- ANSI A156.12 - Interconnected Locks
- ANSI A156.13 - Mortise Locks and Latches
- ANSI A156.14 - Sliding and Folding Door Hardware
- ANSI A156.15 - Release Devices-Closer Holder, Electromagnetic and Electromechanical
- ANSI A156.16 - Auxiliary Hardware
- ANSI A156.17 - Self Closing Hinges and Pivots
- ANSI A156.18 - Materials and Finishes
- ANSI A156.21 - Thresholds
- ANSI A156.22 - Door Gasketing Systems
- ANSI A156.25 - Electrified Locking Devices
- ANSI A156.26 - Continuous Hinges
- ANSI A156.28 - Keying Systems

### ANSI NUMBERING SYSTEM

Letter "A" denotes section "A" of ANSI Standard

#### First Numeral

The first numeral indicates general type of material used.

- 1 – Cast, Forged or Extruded Brass or Bronze
- 2 – Wrought Brass or Bronze
- 5 – Stainless Steel, 300 Series
- 8 – Wrought Steel, Forged Steel or Malleable Iron

#### Second Numeral

The second numeral identifies type of product.

- 1 – Full Mortise Hinges
- 2 – Half Mortise Hinges
- 3 – Full Surface Hinges
- 4 – Half Surface Hinges
- 5 – Anchor, Pivot Reinforced or Thrust Pivot Unit and Hinge Sets
- 6 – Olive Knuckle Hinges
- 7 – Pivot Hinges
- 8 – Rescue Hardware

#### Third Numeral

The third numeral identifies the function or the description of the item or both.

- 1 – Anti-Friction Bearing
- 2 – Anti-Friction Bearing – Swing Clear
- 3 – Plain Bearing
- 4 - Thru 0 – Special Conditions

#### Fourth Numeral

The fourth numeral designates the grade classification of the item.

- 1 – Grade 1 – 4BB Extra Heavy Weight – 2,500,000 Cycles
- 2 – Grade 2 – 2BB Standard Weight – 1,500,000 Cycles
- 3 – Grade 3 – Plain Bearing – 350,000 Cycles

*Information taken from: ANSI A156.1 (Butts and Hinges)*

### CODES AND ILLUSTRATIONS

#### Units of Measure

- EACH - Item in a box either with or without screws.
- PACK - Items poly bagged (1 or more) per bag.
- PAIR - Items (1 or more) pair per box.
- SET - Items (1 or more) sets per box.

#### Illustrations

Pictures and illustrations shown in this catalog are for general product information only and are not meant to be used as templates. Contact Hager Companies Sales and Service for templates or installation instructions, or go to [www.hagerco.com](http://www.hagerco.com) to download.

#### Packaging

The following codes have been established to provide clarification of packaging methods. The basic code letter(s) are shown in parenthesis in the unit column of each page. The letter designation refers to the standard Hager Pack.

Hager Companies reserves the right to change the packaging methods when deemed necessary and to increase or decrease quantities to make full case quantities on a specific item.

- B = Boxed
- PB = Poly Bag
- BLK = Bulk Pack
- SET = Set

#### APPROVAL

Hager Companies has been approved by the U.S. Corps of Engineers and by the Veterans Administration for use on all veterans hospitals and on other buildings that would come under their jurisdiction. Approved samples are on file at the National Bureau of Standards, Washington, D.C.



## GENERAL INFORMATION

### DOOR MATERIALS AND FREQUENCY

Approximate Door Weights - pounds per square foot					
Door Material	Door Thickness				
	1-3/8" (35 mm)	1-3/4" (45 mm)	2" (51 mm)	2-1/4" (57 mm)	2-1/2" (64 mm)
Ash	4.5	5.3	6.0	6.8	7.5
Birch	3.8	4.3	5.0	5.6	6.3
Fir	3.0	3.5	4.0	4.5	5.0
Mahogany	4.5	5.3	6.0	6.8	7.5
Oak	6.0	7.3	8.0	9.0	10.0
White Pine	3.0	3.5	4.0	4.0	5.0
Residential Hollow Core	1.7	2.5	-	-	-
Institutional Hollow Core	-	3.2	-	-	-
Staved Core	3.3	4.2	-	5.4	-
Particle Board Core	4.0	5.0	-	-	-
Mineral Core	-	4.0	-	-	-
Acoustical Core	-	8.3	-	10.6	-
Fiberglass	-	3.8	-	-	-
Hollow Metal 18 gauge	4.3	4.6	-	-	-
Hollow Metal 16 gauge	5.4	5.8	-	-	-
Hollow Metal 15 gauge	6.2	6.5	-	-	-
Hollow Metal 14 gauge	7.0	7.3	-	-	-
Hollow Metal 13 gauge	8.3	8.7	-	-	-
Hollow Metal 12 gauge	9.9	15.5	-	-	-
Hollow Metal 11 gauge	11.2	11.6	-	-	-
Hollow Metal 10 gauge	12.8	13.0	-	-	-
1-3/4" Wood + 1/16" Lead	-	8.7	-	-	-
1-3/4" Wood + 1/8" Lead	-	12.4	-	-	-
1-3/4" Wood + 3/16" Lead	-	16.1	-	-	-
1-3/4" Wood + 1/4" Lead	-	19.8	-	-	-
1-3/4" Wood + 3/8" Lead	-	27.2	-	-	-
1-3/4" Wood + 1/2" Lead	-	34.6	-	-	-

Frequency of Use		
Type of Building	Daily	Yearly
<b>High Frequency</b>		
Large Department Store Entrance	5,000	1,825,000
Large Office Building Entrance	4,000	1,460,000
Hospital Corridor and Surgical Doors	3,000	1,095,000
School Entrance	1,250	456,250
Office Stairwell	500	182,500
<b>Medium Frequency</b>		
Hospital Consultation Rooms	100	36,500
School Corridor	100	36,500
Office Building Corridor	80	29,200
Storage Room	50	18,250
<b>Low Frequency</b>		
Residential Entrance	30	10,950
Residential Interior	20	7,300

Note: Frequency chart recommendations apply to all average weight doors. Heavy ball bearing hinges should be used for doors having a thickness of 2" (51 mm) or more over a width of 3' 4" (1016 mm). Any doors on which a closing device is used should be equipped with bearing hinges, regardless of frequency of use.

## GENERAL INFORMATION

### TRADE ORGANIZATIONS



#### **The American Hardware Manufacturers Association**

The purpose of AHMA is to promote the sale of American made products through the hardware distribution system. Hager Companies is a member in good standing of the American Hardware Manufacturers Association, the owner of the AHMA registered trademark.

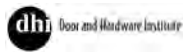

#### **Door and Hardware Institute**

The purpose of the Institute is to represent the architectural openings industry as a major component of the construction industry. Hager recommends the service of a qualified A.H.C. for the preparation of hardware specification and schedules. Members of this society are qualified through years of experience and rigid examination to handle the most complex hardware situations.



#### **Builders Hardware Manufacturers Association**

The Builders Hardware Manufacturers Association is a national trade group of manufacturers whose products are classified (Standard Industrial Classification #34294) and most familiarly recognized as locks and builders hardware. Where applicable this catalog shows BHMA numbers in conjunction with Hager numbers. The purpose is to advance the interests of the Builders Hardware Industry in all lawful ways.



#### **Association of Millwork Distributors**

The Association of Millwork Distributors has continued to be recognized as the leader in the millwork wholesale distribution industry for almost half a century. The Southern Sash and Door and Northern Sash and Door organizations, joined forces 42 years ago to become the National Sash and Door Jobbers Association (NSDJA). On the 40th Anniversary of NSDJA, the association changed its name to the Association of Millwork Distributors (AMD). This change signified that the leadership and membership of the association recognized the changes in the millwork industry.

AMD represents the millwork industry with over 1,000 distributor, manufacturer, and manufacturer's representative companies, nationally and internationally, that promote the best in products and services that the millwork industry has to offer.

AMD is a chief advocate, actively engaged in issues regarding standards, trends, and resources in the millwork distribution industry. AMD monitors Congressional activity and various regulatory agencies, continually seeking to promote industry benefits for AMD members.

AMD is committed to being an essential resource for its members, providing educational products, networking events, and pertinent industry information to help members stay updated on millwork industry trends and available opportunities.

## GENERAL INFORMATION

### Florida Building Codes



The following products have been approved for statewide acceptance by the Florida Building Commission pursuant to Rule 9B-72.090, F.A.C., for approval of products and systems for use on Exterior Swinging Door Assemblies, in compliance with the structural requirements of the 2007 Florida Building Code.

Verification of Florida Statewide acceptance can be found at [www.floridabuilding.org](http://www.floridabuilding.org) under the Product Approval section.

### Severe Windstorm Resistant Components for Swinging Door Assemblies - ANSI A250.13 - 2003 Standard

Certified Hardware	Assembly Configuration	Door Size	Door Stiffness Class	Design Load	Florida Certification Number (FL.#)
3100 Series Grade 1 Deadbolt	Single - Out Swing	3-0 x 7-0	-	1150 lbf (100 psf)*	6118
	Single - Out Swing	4-0 x 8-0	-	1150 lbf (70 psf)*	
3200 Series Grade 2 Deadbolt	Single - Out Swing	3-0 x 7-0	-	1150 lbf (100 psf)*	6118
	Single - Out Swing	4-0 x 8-0	-	1150 lbf (70 psf)*	
3400 Series Grade 1 Lockset	Single - Out Swing	3-0 x 7-0	-	1150 lbf (100 psf)*	6118
	Single - Out Swing	4-0 x 8-0	-	1150 lbf (70 psf)*	
3500 Series Grade 2 Lockset	Single - Out Swing	3-0 x 7-0	-	860 lbf (80 psf)*	7683
	Single - Out Swing	4-0 x 8-0	-	860 lbf (50 psf)*	
3800 Series Grade 1 Mortise	Single - Out Swing	3-0 x 7-0	-	1150 lbf (100 psf)*	12932
	Single - Out Swing	4-0 x 8-0	-	1150 lbf (70 psf)*	
4500 Rim Exit Device	Single - Out Swing	4-0 x 8-0 max.	I	+/- 70 psf - 350 ft-lbs Impact	9481
4500 SVR Exit Device	Out Swing	8-0 x 8-0 pair max.	I	+/- 50 psf - 350 ft-lbs Impact	13178
4700 Rim Exit Device	Single - Out Swing	4-0 x 8-0 max.	I	+/- 40 psf - 350 ft-lbs Impact	8293
780-112 Roton Hinge	Single Swing	4-0 x 8-0 max.	I	1150 lbf (72 psf)* - 350 ft-lbs Impact	6118
780-111, 780-224, 780-226 Roton Hinge (SD & HD)	Single Swing	4-0 x 8-0 max.	I	1150 lbf (72 psf)* - 350 ft-lbs Impact	13776
BB1191 Hinge	Single - Out Swing	-	-	1780 lbf**	6118
1279, 1191, BB1279, BB1168, BB1199	Single - Out Swing	-	-	1780 lbf**	13776

\* Load in parenthesis indicates the equivalent load in pounds per square foot based on indicated door size and door stiffness (if applicable). This load is based on the hardware item taking half of the force applied to the door assembly by the wind load and the hinges taking the other half.

\*\* This load indicates the design load for a single butt hinge. Maximum wind load should be calculated based on door size, number of hinges used, and the other available door hardware on the door assembly.

## GENERAL INFORMATION

### Basic Requirements for an Opening to be Classified as Fire-rated

The wall, frame, and door all have to be fire-rated. For example, as it would not make much sense to put a labeled door in a non-rated wall just as you cannot put a non-labeled door in a rated wall and call the opening fire-rated. The purpose of a fire-rated opening is to retard fire for a specific length of time. All components of the opening have to be rated. When an opening is also required to be "S" (smoke) labeled then additional gasketing items will be required to comply with the code.

Every swinging fire door must have a listed and labeled self-latching device to engage the strike to be fire-rated. Push and pull plates cannot be used on a fire-rated door. The door has to latch into the frame when closed so it stays closed. The latch prevents the door from opening during a fire if something falls against it. This means you must use at least a passage lock set on the door. Deadbolts cannot be used in place of a latching device because they are not self-latching.

The door must be self-closing to be fire-rated. A properly sized, listed and labeled closing device is part of basic fire door hardware requirements. If the door is left open during a fire, then that opening cannot retard the fire as it was meant to do; the door needs to close after somebody passes through it. This is usually done by a door closer or, in some cases, spring hinges.

Steel ball bearings and steel based hinges must be used on fire-rated doors. Brass, bronze and other base materials cannot be used, unless tested as an assembly. Continuous hinges are allowed as tested. Plain bearing hinges cannot be used. Bearing hinges minimize wear from everyday operation and help prevent door sag. During a fire, the door needs to operate smoothly so closers and latching devices work properly. Some manufacturers may provide doors with non-bearing type hinges only when they are part of the listed assembly.

Fire-rated and listed louvers can be installed on fire doors but they have to be a fusible link type. This means that once the heat from the fire reaches a certain temperature (usually 105°F) (41° C), the fusible link will melt which causes the louver blades to close. This will help prevent the spread of fire. The maximum size for these louvers is 24" x 24" (610 x 610 mm). There is no glass allowed in a fire-rated door if it has a louver and no louvers can be installed in a 3-hour rated door.

Basic fire door frames do not have hourly ratings. The exception being frames specially labeled for less than 3 hours. Frames bearing a recognized fire label may support a 3-hour, 1-1/2-hour, 3/4-hour or a 1/3-hour door. Frames used in masonry walls can be used with a maximum 3-hour fire door. While frames in drywall are intended for use with fire doors rated up to 1-1/2-hour, some manufacturers have tested for a 3-hour frame in drywall. Verify with your manufacturer for individual listing.

**Remember, these are basic requirements. Codes differ from area to area and are enforced by the Authority Having Jurisdiction (AHJ)**

The purpose of a fire-rated opening is to retard fire for a specific period of time.

The hourly designation indicates the duration for the fire test exposure and is known as the fire protection rating.

**A Label:** 3-hour rating (for a 4-hour wall): These doors are used for openings in walls separating buildings that are joined together. They are metal doors and glass is allowed as tested. "A" label doors might not require additional seals applied to the frame, check with your individual manufacturer's procedure. Typically, a hollow metal door needs no added seals. Metal and some composite doors expand when heated. The door itself effectively seals the opening and often does not require the addition of an edge sealing system for the fire label. However, this door would still need a smoke gasket if it were functioning as a smoke control door.

**B Label:** 1-1/2-hour rating (for a 2-hour wall): These doors are usually used for stairwell doors but are sometimes used at all the rated walls in a building (i.e., mechanical or electrical rooms). One-hundred square inches of exposed glass per door leaf is allowed. These are mostly wood composite and hollow metal doors. A "B" label 1-hour rating (1-hour wall) exists for use in buildings less than four stories tall; this rating currently only applies to wood doors. "B" label fire doors require the addition of an edge-sealing system (category "G" gasket) to the frame to comply with the new positive pressure test method. Some wood doors do not require the additional category "G" gasket; check with your manufacturer for availability.



## GENERAL INFORMATION

**C Label:** 3/4-hour rating (for a 1-hour wall): These doors are used for openings from a corridor into another room in the same building. 1,296 square inches of exposed glass is allowed per vision light. These are mostly wood composite doors. "C" label fire doors require the addition of an edge-sealing system (category "G" gasket) to the frame to comply with the new positive pressure test method. Some wood doors do not require the additional category "G" gasket, check with your manufacturer for availability.

**D Label:** 1-1/2-hour rating (for a 2-hour wall): These are hollow metal doors used in exterior walls subject to severe fire exposure from outside the building. One-hundred square inches of exposed glass per door leaf is allowed. Check with your manufacturer's listing for the addition of a category "G" gasket to meet positive pressure requirements.

**E Label:** 3/4-hour rating (for a 1-hour wall): These are hollow metal doors used in exterior walls subject to moderate to light fire exposure from the outside of the building. 1,296 square inches of exposed glass is allowed per vision light. Check with your manufacturers listing for the addition of a category "G" gasket to meet positive pressure requirements.

**1/3-Hour Door:** 20-minute rating (for a 1-hour wall): These doors do not have a letter designation for their rating and can be a wood or particle core door. 1,296 square inches of exposed glass is allowed per vision light. They are tested with or without hose stream. Doors tested without hose stream are specially labeled: "Twenty Minute-Rating Without Hose Stream." These doors are used on condo/apartment entrances, offices of a 1-hour rated corridor wall and other applications where smoke and draft control is the primary concern.

**S Label:** The letter "S" is the designation on a door's fire label indicating it can be used as a Smoke Control Door. Door manufacturers are allowed to put an "S" on a fire label when the door opening has passed the air infiltration test. The door opening does not become approved for a Smoke and Draft Control unit until an approved category "H" gasket system has been installed on the frame. The federal government, many owners and some states require at least some openings to be labeled for smoke as well as fire. This is not limited to 20-minutes but includes all fire labeled doors that are rated 20-minutes and above. The addition of an approved category "H" smoke control gasket completes the installation instructions necessary to validate the labeled door to become a Smoke Control Door.

All of the labels listed above have the capability of being both fire and smoke barrier openings. Openings requiring smoke labels are detailed either by the fire authority having jurisdiction, local code, NFPA 101 or NFPA 5000.



**One Family. One Brand. One Vision.™**

[www.hagerco.com](http://www.hagerco.com)

# Commercial Hinges



In the mid 1800s, Charles Hager had a successful business forging metal wheel rims and hinges for wagons headed west. As a smart businessman who valued quality and innovation, Charles soon became a pioneer in product development, designing a revolutionary hinge that became a prototype for more than 5,000 hinges to follow.

Today, the Hager name is synonymous with commercial hinges. In fact, we are the industry's premiere designer and manufacturer of commercial hinges, with a product line that offers one of the widest varieties of sizes, shapes, and finishes--all of which meet or exceed ANSI standards. With legendary quality, time-tested durability, and consistent superior performance, Hager is the one name, and one brand, you can count on to provide it all.

## Table of Contents

General Information .....	2
Specialty Hinges .....	8
Electric Hinges .....	10
Hinge Selector .....	11
Full Mortise .....	13
Half Mortise .....	26
Full Surface .....	28
Half Surface.....	31
Aluminum Entrance .....	34
Swing Clear .....	35
Anchors.....	38
Pivots.....	40
Detention Hardware .....	44
Accessories.....	45





## GENERAL INFORMATION - SELECTING A HINGE

### Determine Type of Hinge

- What is the door material (wood, stainless steel, fiberglass, or hollow metal)?
- What is the frame material (wood, stainless steel, channel iron, or hollow metal)?

Hinges are manufactured in accordance with ANSI/BHMA A156.1. Self-closing hinges and pivots are in accordance with ANSI/BHMA A156.17 using three hinges per opening on a 3'0" x 7'0" x 1-3/4" (914 mm x 2134 mm x 44 mm) door.

Round corners are available in 1/4" (6 mm) (standard) or 5/8" (16 mm) radius.

#### Full Mortise

Both leaves are mortised, one leaf in the door and one leaf in the frame (wood door or hollow metal door with wood or hollow metal frame).

Example: BB1279 4-1/2" x 4-1/2" (114 mm x 114 mm), US26D

#### Half Mortise

One leaf is mortised in the door and the other is surface applied to the frame (hollow metal door with channel iron frame).

Example: BB1109 4-1/2" (114 mm), US26D

#### Full Surface

Both leaves are applied to the surface, one to the door and the other to the frame (metal clad door or hollow metal door with channel iron frame).

Example: BB2171 5" (127 mm), USP

#### Half Surface

One leaf is mortised in the frame and the other is surface applied to the face of the door (wood door with wood frame or hollow metal door with hollow metal frame).

Example: BB1163 5" (152 mm), US26D

### Select the Proper Weight and Bearing Structure

Because of the variety of door sizes and weights, hinges are placed into three groups:

#### Heavy Weight - Ball Bearing

Example: BB1199 5" x 5" (127 mm x 127 mm), US32D

#### Standard Weight - Ball Bearing

Example: BB1279 4-1/2" x 4-1/2" (114 mm x 114 mm), US26D

#### Standard Weight - Plain Bearing

Example: 1279 4" x 4" (102 mm x 102 mm), US10

#### Hinge Type Minimum Cycle Requirements

Plain Bearing = 350,000

Standard Weight Ball Bearing = 1,500,000

Heavy Weight Ball Bearing = 2,500,000

There are three factors that determine the weight and structure of the hinge: weight and width of the door and frequency of use. It is advisable to include the approximate weight of additional hardware that will be installed on the door.

### Determine the Size of Hinge

The first thing to find is the height of the hinge. Follow the examples below. These are only examples. Job situations will offer many more variables.

Only on the full mortise hinges are there two dimensions, such as a 4-1/2" x 4-1/2" (114 x 114 mm). The first dimension indicates the height and the second dimension indicates the width when the hinge is in the open position.

#### Height of Hinge

Thickness of Door	Width of Door	Height of Hinge
1-3/8" (35 mm) Door	To 32" (813 mm)	3-1/2" (89 mm)
1-3/8" (35 mm) Door	32" to 36" (813 to 914 mm)	4" (102 mm)
1-3/4" (45 mm) Door	To 36" (914 mm)	4-1/2" (114 mm)
1-3/4" (45 mm) Door	36" to 48" (914 to 1219 mm)	5" (127 mm)
1-3/4" (45 mm) Door	Over 48" (1212 mm)	6" (152 mm)
2", 2-1/4", 2-1/2" Door (51, 57 & 64 mm)	To 42" (1067 mm)	5" (127 mm) Heavy Weight
2", 2-1/4", 2-1/2" Door (51, 57 & 64 mm)	Over 42" (1067 mm)	6" (152 mm) Heavy Weight

#### Width of Hinge

There are three dimensions to know in order to determine the minimum width of the hinge: door thickness, hinge backset, and clearance required.

1. When figuring the calculations for a wood door and wood frame, the door is flush with the casing or face of the frame. When figuring the calculations for a wood or metal door with a hollow metal frame, the door is inset approximately 1/8" (3.2 mm).
2. For doors up to 2-1/4" (57 mm) thick, the hinge backset is 1/4" (6.4 mm) from the back face of the door.
3. For doors over 2-1/4" (57 mm) thick, the hinge backset is 3/8" (9.5 mm) from the back face of the door.

Once these dimensions are known, the formula can then be applied. **Take the door thickness, subtract the backset, multiply by two, and add the clearance required.** If the hinge size is not standard, then go to the next larger hinge width. If the width of the hinge is greater than the height of the hinge [example: 4-1/2" x 6" (114 mm x 152 mm)] this is referred to as a wide throw hinge. This would apply only to full mortise hinges.





## GENERAL INFORMATION - SELECTING A HINGE

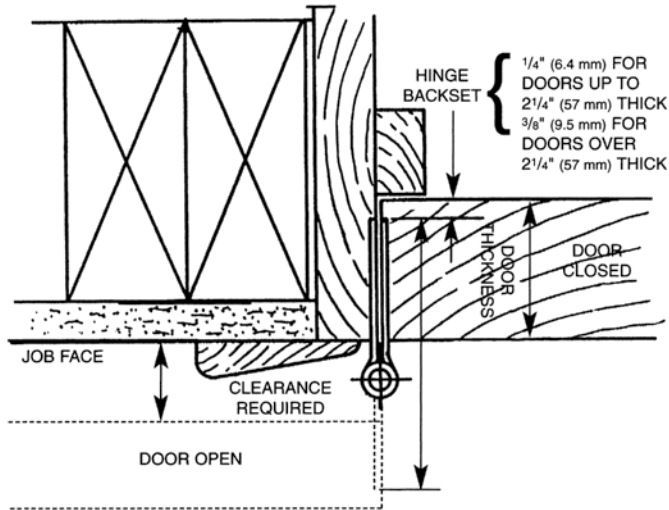

Doors up to 60" (1524 mm) in height shall be provided with two hinges and an additional hinge for each additional 30" (762 mm). Where spring hinges are used, at least two shall be provided.

Full Mortise Hinge Height	Frequency of Use	Max Door Weight	Maximum Door Width	Type
4-1/2" (114 mm)	Low	75	36" (914 mm)	1279
4-1/2" (114 mm)	Medium	150	36" (914 mm)	BB1279
4-1/2" (114 mm)	High	150	36" (914 mm)	BB1168
5" (127 mm)	Low	100	36" (914 mm)	1279
5" (127 mm)	Medium	175	36" (914 mm)	BB1279
5" (127 mm)	High	175	36" (914 mm)	BB1168
6" (152 mm)	Low	125	36" (914 mm)	1279
6" (152 mm)	Medium	230	36" (914 mm)	BB1279
6" (152 mm)	High	230	36" (914 mm)	BB1168

Door Thickness	Standard Backset	Max. Clearance Provided	Width of Hinge
1-3/8" (35 mm)	1/4" (6.4 mm)	1-1/4" (32 mm) 1-3/4" (45 mm)	3-1/2" (89 mm) 4" (102 mm)
1-3/4" (45 mm)	1/4" (6.4 mm)	1" (25 mm) 1-1/2" (38 mm) 2" (51 mm) 3" (76 mm)	4" (102 mm) 4-1/2" (114 mm) 5" (127 mm) 6" (152 mm)
2" (51 mm)	1/4" (6.4 mm)	1" (25 mm) 1-1/2" (38 mm) 2-1/2" (64 mm)	4-1/2" (114 mm) 5" (127 mm) 6" (152 mm)
2-1/4" (57 mm)	1/4" (6.4 mm)	1" (25 mm) 2" (51 mm)	5" (127 mm) 6" (152 mm)
2-1/2" (64 mm)	3/8" (9.5 mm)	3/4" (19 mm) 1-3/4" (45 mm)	5" (127 mm) 6" (152 mm)

### Minimum Width of Hinge

#### Determine the Number of Hinges

The next determination is the number of hinges per door leaf. A general rule of thumb: one hinge for every 30" (762 mm) of door height or fraction thereof.

#### Door Height

Up to 60" (1524 mm)  
Over 60" (1524 mm) and not over 90" (2286 mm)  
Over 90" (2286 mm) and not over 120" (3048 mm)

#### Number of Hinges

2 Hinges  
3 Hinges  
4 Hinges

For doors with a width greater than 37" (940 mm) to 48" (122 mm), an extra hinge could be used for additional strength. The extra hinge helps support the additional weight and tension applied to the frame created by the wider door width.

#### Determine Type of Material

##### Steel

This has great strength, but it is a corrosive material. If the atmosphere that steel is used in is not stable, steel will begin to rust. The best application for steel is in a controlled environment, such as inside a building where the temperature and humidity are controlled.

##### Stainless Steel

This also has great strength. It is rust resistant and can be polished to a satin or bright finish. For highly corrosive areas, 316 grade or clear coat over 304L may be recommended. Hager Companies standard grade stainless steel is 304L.

##### Brass

This material is non-corrosive, rust resistant, and very decorative. However, it has less strength than the steel or stainless steel material. Brass is often used where appearance is of great concern as it may be polished and plated in various finishes.

Both steel and stainless steel hinges may be used on listed fire rated or labeled door openings. Brass material may not be used on fire rated or labeled openings because of the low melting point.



## GENERAL INFORMATION - SELECTING A HINGE

### Determine Type of Finish

All steel and brass material hinges can be plated to match the available finishes that are listed in the American National Standards Institute, standard ANSI/BHMA A156.18 Materials and Finishes.

### Special Resisting Finishes

A nickel undercoat is a **standard process** that is applied to all **steel basted PLATED hinges**. The nickel undercoat is an **optional process** for **steel based PAINTED hinges** and must be ordered as an option if desired.

Note: Hager Companies only warrants US10B finish over brass base material. If steel base is necessary, Hager Companies recommends US10A lacquer finish.

### Antimicrobial Protection

Hager Companies uses a powder coat process to apply antimicrobial treated coating to guarantee durability and protection. Antimicrobial resistance on products is affected by moisture in the air. Silver ions interact with humidity and are released creating a cleaner surface.

### Architectural Finish Symbols Powder Coat Finishes

#### B.H.M.A. Symbol Base Material

\*US3SC only available on AB800, AB850, and CB1191.

Hager	Description	Steel	Brass & Bronze	Stainless Steel	HEWI#
L1	Flat Black	693	693	N/A	N/A
L2	Dark Bronze	695	695	N/A	N/A
L3	Medium Bronze	694	694	N/A	N/A
LS	Luma Sheen® Aluminum Paint	689	689	N/A	N/A
13P	White	N/A	N/A	N/A	1
14P	Off White	N/A	N/A	N/A	5A
15P	Grey	N/A	N/A	N/A	5
33P	Yellow	N/A	N/A	N/A	14
34P	Red	N/A	N/A	N/A	33
35P	Green	N/A	N/A	N/A	6
36P	Blue	N/A	N/A	N/A	52
83P	Black	N/A	N/A	N/A	8
84P	Olive	N/A	N/A	N/A	62
85P	Brown	N/A	N/A	N/A	9
86P	Burgundy	N/A	N/A	N/A	30
87P	Dark Green	N/A	N/A	N/A	60
88P	Dark Blue	N/A	N/A	N/A	50

U.S. & Hager	Description	Steel	Brass & Bronze	Stainless Steel
2C	Plain Zinc Plate	603	N/A	N/A
H2H x BP	Mechanical Galvanized; Steel Only	N/A	N/A	N/A
3	Bright Brass	632	605	N/A
3A	Bright Brass - Unlacquered	N/A	N/A	N/A
3SC*	Brass SecureCoat® Lifetime Bright Brass Finish	N/A	N/A	N/A
4	Satin Brass	633	606	N/A
5	Satin Brass, Oxidized	638	609	N/A
9	Bright Bronze	637	611	N/A
10	Satin Bronze	639	612	N/A
10A(US11)	Antique Bronze, Lacquered	641/643	N/A	N/A
10B	Antique Bronze, Oiled	640	613	N/A
10Z	Antique Bronze - SPL	N/A	N/A	N/A
10D	Black Nickel, Oiled	640	613	N/A
SS/10Z	Antique Bronze, Stainless Steel	N/A	N/A	N/A
14	Bright Nickel	645	618	N/A
14B	Black Nickel, Bright	N/A	N/A	N/A
15	Satin Nickel	646	619	N/A
15A	Satin Nickel, Nickel Oxidized & Highlighted	647	620	N/A
17A	Black Nickel, Dull	648	621	N/A
26	Bright Chromium Plated	651	625	N/A
26D	Satin Chromium Plated	652	626	N/A
32	Stainless Steel Metal, Bright	N/A	N/A	629
32D	Stainless Steel Metal, Bright (304)	N/A	N/A	630
32D (316)	Stainless Steel Metal, Satin (316)	N/A	N/A	630
32D (CLR)	Stainless Steel Metal, Satin (Clear Coat)	N/A	N/A	630
P	Prime Coat	600	600	N/A
PS	Plain Steel	N/A	N/A	N/A
L1	Flat Black	693	693	N/A
L2 (90P)	Dark Bronze	695	695	N/A
L3	Medium Bronze	694	694	N/A
LS	Luma Sheen®	689	689	N/A





## GENERAL INFORMATION

### Bearing Options

When using steel based hinges, special options are available such as stainless steel pins, stainless steel bearings and stainless steel raceways.

**Ball Bearing (BB)** - Ball bearings are engineered to throw the knuckle weight against specially hardened steel raceways, which ride on the bearing surfaces. The one-piece cup protects the bearings from moisture and dust. The cup supports no weight so it is not subjected to functional friction, pressure or wear. Lateral wear is minimized because the pin is held against thrust by the hardened steel top and bottom raceways. The bearing units are securely press-fit to the leaf knuckle to prevent loss when the hinge is disassembled.

**Oilite Bearings (OB)** - The oilite bearing is made of porous metal that has been press-formed and impregnated with oil. The slight pressure and heat generated when the door is operated causes the oil to come to the surface of the bearing causing the surface to be slick and smooth.

**Anti-Friction Nylon Bearings (AB/CB)** - These are made of resilient engineering plastics that provide a self-lubricant and very strong bearing surface. The nylon acts as a cushion for the door yet it allows the door to flow smoothly on the surface of the nylon with an extremely low wear factor. (AB is standard on 3-knuckle hinges. CB is an option for 5-knuckle hinges).

### Care and Maintenance

- Hinges must be free swinging without any binding. The use of shims to align hinges, if required, is satisfactory. Steel shims to be used on labeled openings.
- Hinges should be well greased and checked on a regular basis for lubrication. We recommend that hinges used in commercial, high-frequency applications or those in extreme environmental conditions be lubricated annually to ensure quiet operation and long life.
- Standard hinges are best lubricated by removing the pin, applying a generous coating of lithium grease, and reinserting the pin by driving it completely down to the shoulder of the pin head.
- Hospital Tip (HT) hinges that have fixed hinge pins have an oil port on the knuckle for the purpose of lubrication.
- Water displacing sprays such as WD-40 are not recommended for hinge lubrication.
- To remove dirt, simply wipe with a soft damp cloth. Abrasive cleaners or lacquer thinner should not be used to clean the surface of hinges. To do so will void any warranty for the product.

### Determine Handing

On some applications it will be necessary to order hinges that are handed. Most manufacturers use the suffix RH (right hand) and LH (left hand). Another general rule of thumb, most manufacturers make the half surface, half mortise and full surface hinges for right hand use. Conversion from right hand to left hand is very simple; take the pin out of the

knuckle, remove the bottom plug, turn the hinge over, replace the plug in the bottom and the pin in the top of the knuckle, and the handing is reversed.

- The hand of a hinge is determined from the key of the door to which it is applied. This is usually the locked side.
- When standing keyside, if the door opens away (into the area) to the right, it takes a right hand hinge (also referred to as RH). If it opens to the left, it takes a left hand hinge (also referred to as LH).
- When standing keyside, if the door opens (out of the area) toward the right, it takes a left hand hinge (also referred to as right hand reverse bevel – RHRB). If it opens to the left, it takes a right hand hinge (also referred to as a left hand reverse bevel – LHRB).

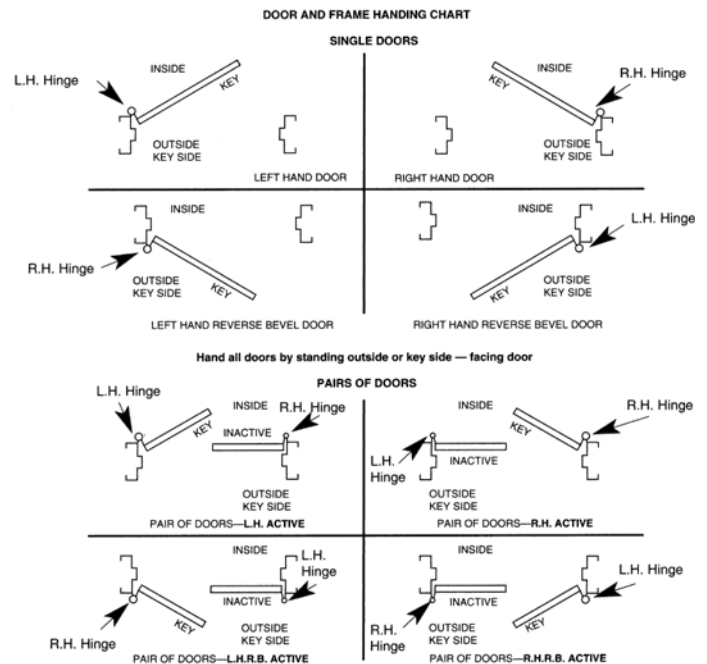

### Additional Considerations

#### Determine Pin and Tip Style

- The standard in the industry is the Flat Button Tip for 5-knuckle hinges.
- The flush/concealed tip is standard on 3-knuckle. If button tip is required, specify Exposed Tip (ET).
- Hospital Tips (HT) are used primarily for security areas in hospitals and in prisons. This tip prevents hanging any objects on the tip of the hinge. Hager provides all hospital tipped hinges with two non-removable cross pins, stainless steel hinge pin, and an oil port for lubrication purposes. If the hinge is ball bearing, the components used for the bearing are made of stainless steel. Using a Hospital Tip on spring hinges voids the UL listing.
- Decorative tips such as Acorn, Ball, Steeple, and Urn are used in highly decorative areas of offices and residences.
- Fast Riveted Pins (FRP) are spun on both ends, making the pin permanent.





**GENERAL INFORMATION**

**Swaging**

Swaging is a slight offset of the hinge leaf at the barrel. This offset permits the leaves to come closer together when the door is in the closed position. If the hinge were to be left in the natural state after the knuckle was rolled, the hinge would be referred to as a "flatback". A flatback hinge has a gap between the leaves of approximately 5/16" (7.9 mm). This would allow heat and air-conditioning to escape, not to mention the unsightly gap between the door and frame. Standard gap (Swag) is 1/16", specify "O" Swag for no gap.

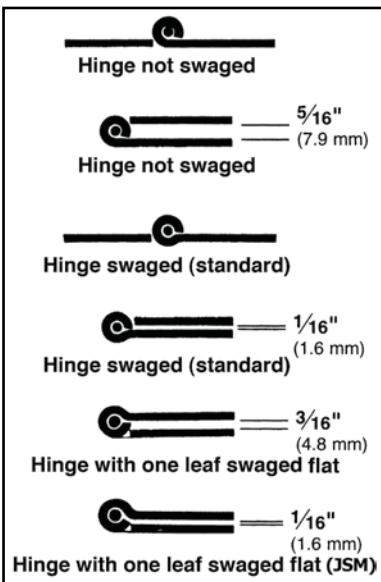

The swaging on standard weight and heavy weight full mortise hinges provides 1/16" (1.6 mm) clearance between the leaves when the leaves are in the closed position. Full mortise hinges used on beveled doors will affect lockside clearance, especially for wide throw applications.

**Security Features**

Three additional features that are commonly used are: Non-Removable Pin (NRP), Safety Stud (SH), and Reverse Security Stud (RSS). **These features are intended as deterrents only.**

Non-Removable Pin



The **Non-Removable Pin (NRP)** hinge barrel is drilled and tapped to receive a small set screw which is tightened against the hinge pin. The pin has a groove in the position where the set screw makes contact, allowing the set screw to seat. The set screw is positioned so it cannot be reached unless the door is opened. If pin removal is necessary, the set screw is merely removed and the pin tapped from the bottom in the usual manner.

Safety Stud



The **Safety Stud (SH)** 3/16" (4.8 mm) projection is a feature that places a stud on one leaf and a locking hole on the other leaf. When the door is closed, the stud is anchored into the opposite leaf. Even if the hinge pin is removed, the door is secure because the leaves are locked together.

Reverse Security Stud



The **Reverse Security Stud (RSS)** 7/16" (11.1 mm) projection is a feature that has a welded stud projecting from the back of both leaves into the reinforcing plate of both the frame and the door. It is intended to keep the hinge locked in place from abuse of battering or trying to shear the hinge and screws. This feature is primarily used in prisons and psychiatric areas.

**Tip Styles**







## GENERAL INFORMATION

### Standard Screw Packs for Full Mortise Architectural Hinges

Part Number	Size	Finish	Screws
700, AB700, 1279, BB1279, EC1100, EC1105, 1250 (with or without NRP), ECBB1100	4-1/2" x 4-1/2" 4-1/2" x 4"	US3, US4, US5, US10, US10A (US11), US10B, US15, US15A, US26, US26D, USP	AMS & AWS
Other than listed above	4-1/2"	Other than listed above	AMS & 1/2 WS
All	3-1/2"	All	AWS & 1/2 MS
All	4"	All	AWS & 1/2 MS
All	5"	All	AMS & 1/2 WS
All	6"	All	AWS & 1/2 MS
All	7"	All	AWS & 1/2 MS
All hinges with decorative tips	All	All	AWS

### Fire-Rated Application

Door Rating (Hr)	Maximum Door Size		Minimum Hinge Size		Type Hinge
	Width	Height	Height	Thickness	
For 1-3/4" (44.5 mm) or thicker doors					
3, 1-1/2, 1, 3/4, 1/2, 1/3	4 (1.22)	10 (3.05)	4-1/2 (114.3)	0.180 (4.57)	Steel, mortise or surface
3, 1-1/2, 1, 3/4, 1/2, 1/3	4 (1.22)	8 (2.44)	4-1/2 (114.3)	0.134 (3.40)	Steel, mortise or surface
1-1/2, 3/4, 1/2, 1/3	3-1/16 (0.96)	8 (2.44)	6 (152.4)	0.225 (5.72)	Steel, olive knuckle or paumelle
3, 1-1/2, 1, 3/4, 1/2, 1/3	4 (1.22)	10 (3.05)	4 (101.6)	0.225 (5.72)	Steel pivots (including top, bottom, and intermediate)
1-1/2, 1, 3/4, 1/2, 1/3	3 (0.91)	5 (1.52)	4 (101.6)	0.130 (3.30)	Steel, mortise or surface
1-1/2, 1, 3/4, 1/2, 1/3	2 (0.61)	3 (0.91)	3 (76.2)	0.092 (2.34)	Steel, mortise or surface
3, 1-1/2, 1, 3/4, 1/2, 1/3	3 (0.91)	7 (2.13)	4-1/2 (114.3)	0.134 (3.40)	Steel, mortise or surface (labeled, self-closing, spring type)
3, 1-1/2, 1, 3/4, 1/2, 1/3	3 (0.91)	7 (2.13)	4 (101.6)	0.105 (2.67)	Steel, mortise or surface (labeled, self-closing, spring type)
For 1-3/8" (34.9 mm) doors					
3, 1-1/2, 3/4, 1/2, 1/3	3 (0.91)	7 (2.13)	3-1/2 (89.9)	0.123 (3.12)	Steel, mortise or surface
3, 1-1/2, 1, 3/4, 1/2, 1/3	2-2/3 (0.81)	7 (2.13)	3-1/2 (89.9)	0.105 (2.67)	Steel, mortise or surface (labeled, self-closing, spring type)

#### Notes:

- All hinges or pivots, except spring hinges, shall be of the ball bearing type. Hinges or pivots employing other anti-friction bearing surfaces shall be permitted if they meet the requirements of ANSI A156.1, Standard for Butts and Hinges. Spring hinges shall be labeled and shall meet the requirements of ANSI A156.17, Standard for Self Closing Hinges and Pivots, Grade 1.
- Heavy weight hinges 4-1/2" (114 mm) high, 0.180" (4.57 mm) thick shall be permitted for use on wide and heavy doors or doors that are subjected to heavy use or unusual stress.
- Some manufacturers can provide fire doors with hinges of lighter weight that are not of the ball bearing type where they are part of a listed assembly and meet the requirements of ANSI A156.1, Standard for Butts and Hinges, and have been tested to a minimum of 350,000 cycles.
- Pivot sets made up of components that are smaller or of a lighter gauge than shown in this table shall be permitted to be used, provided they meet the requirements of ANSI A156.4, Door Controls (Closers) and are in accordance with the manufacturer's label service procedures.



**SPECIALTY HINGES**

Spring



NFPA 80 has restricted the use of architectural grade spring hinges to fire-rated doors of a maximum size of 3'0" x 7'0" (914 mm x 2134 mm). Hager spring hinges have been tested and labeled for up to a 4'0" x 8'0" (1219 mm x 2438 mm) door when a minimum of three springs are used. Spring hinges must be used with ball bearing hinges. Do not use plain bearing hinges with spring hinges.

Air Transfer Hinge (ATH)



Pneumatic transfer hinge is used to transfer as much as 120 pounds of air pressure through the hinge in order to operate an air modified lock or exit device. Pneumatic power may be used in explosion-proof areas or where electric power is not sufficient to perform the necessary job.

Raised Barrel and Jamb Surface Mount

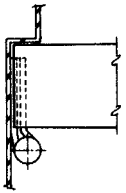

Jamb Surface Mount

This option is used when the door is set back into the frame. The hinge knuckle is offset to allow it to clear the obstruction of the frame. There are three different types of applications:

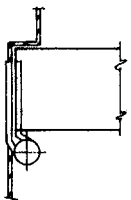

Raised Barrel Square

On the **Jamb Surface Mount (JSM)** application, the door is double mortised to accommodate both hinge leaves; it is also referred to as double mortise. The Jamb Surface Mount may be applied to either a square or beveled edged door. For cased opening, sometimes referred as one leaf swagged flat.

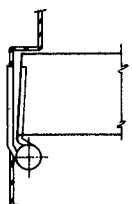

Raised Barrel Beveled

The **Raised Barrel for Square Edged (RBS)** and the **Raised Barrel for Beveled Edged (RBB)** door applications are mortised into the frame and door as a standard full mortise hinge. Standard offset is 3/8" (10 mm). Depending on the depth of the frame, all three of these applications may restrict the degree of opening. Specify handing and door thickness.

Swing Clear



This is used when the passage area must be the full width of the opening. Swing clear hinges are designed to swing the door completely clear of the opening when the door is opened 95°. Assembled RH, reversible to LH. Can be ordered as LH.

Detention



Investment cast full mortise hinges (IHTHB953 Series) are the standard 4-1/2" x 4-1/2" (114 mm x 114 mm) size with a mortise depth of 0.187" (4.7 mm). These hinges can carry doors weighing up to 600 pounds.

Anchor



The anchor hinges are intended for use on heavy wood or hollow metal doors in high frequency applications such as hospitals, schools, and public use buildings. These hinges are especially designed for use on doors where additional hardware (door closers or holders) may cause excessive strain or abuse to the door, frame, and/or hinges.

Anchor plates may be attached to either the frame and/or door. This prevents the hinges from pulling loose on the door or the frame.

There are two variations of the reinforcing/anchor hinge: one has a single extension leaf which is mortised into the frame only; the second has two extension leaves. One leaf is mortised into the frame and the other leaf is mortised into the top edge of the door. It will be necessary to know if the doors are square edged or beveled edged.

Aluminum Entrance



A slip-in hinge, plain bearing or ball bearing, is used with aluminum doors and frames. These hinges are manufactured for low to average frequency and medium weight aluminum doors and frames.

1277 or BB1277 – Both leaves are drilled and tapped for insertion into a slot in the door and the frame.

1278 or BB1278 – One leaf has the standard template hole punch and countersinking and the other leaf is drilled and tapped for insertion into a slot in the door or frame.





## SPECIALTY HINGES

### DROP LEAF HINGES



**BB1279**  
**Ball Bearing - Standard Weight**

- BB1168**  
**Ball Bearing - Heavy Weight**
- Drop leaf applied to door will lower the door away from the head 1/8"
  - Adjustable to 1/16" drop by repositioning and removing one of the 1/16" spacers
  - Non-rising removable pin with button tip and plug
  - Handed. Non-reversible
  - Also available 1/4" drop

### SHORT LEAF HINGES



- BB1279**  
**Ball Bearing - Standard Weight**
- Two ball bearings
  - Steel with steel pin
  - For use on medium doors requiring medium frequency service

- BB1191**  
**Ball Bearing - Standard Weight**
- Two ball bearings
  - Brass with stainless steel pin or stainless steel with stainless steel pin
  - For use on medium doors requiring medium frequency service

Hinge Size		Gauge of Metal	Hole Count	Screw Size	
Inches	mm			Machine	Wood
4-1/2 x 4-1/2	114 x 114	0.134	8	1/2 x 12-24	1-1/4 x 12

Note: Additional sizes and hinges available. Contact Hager Customer Service for information.

- BB1168**  
**Ball Bearing - Heavy Weight**
- Four ball bearings
  - Steel with steel pin
  - For use on heavy weight doors requiring high frequency service

### UNEQUAL LEAF HINGES



- BB1279**  
**Ball Bearing - Standard Weight**
- Two ball bearings
  - Steel with steel pin
  - For use on medium doors requiring medium frequency service

- BB1168**  
**Ball Bearing - Heavy Weight**
- Four ball bearings
  - Steel with steel pin
  - For use on heavy doors requiring high frequency service
  - For use when door and frame have 4-1/2" and 5" cut-outs
  - An equal amount of material is trimmed from the top and bottom leaf
  - Two/Four ball bearings
  - Non-rising removable pin with button tip and plug
  - Handed. Right hand standard.
  - Unequal top/bottom available. Contact Hager Customer Service for information

- BB1199**  
**Ball Bearing - Heavy Weight**
- Four ball bearings
  - Brass with stainless steel pin or stainless steel with stainless steel pin
  - For use on heavy doors requiring high frequency service
  - Short leaf applied to door will move the door 1/8" away from the stop. Reverse movement is accomplished by applying the short leaf to the frame.
  - Non-rising removable pin with button tip and plug
  - Handed. Right hand standard. Reversible to left hand.

Hinge Size		Gauge of Metal	Hole Count	Screw Size	
Inches	mm			Machine	Wood
4-1/2 x 4-3/8	114 x 111	0.134	8	1/2 x 12-24	1-1/4 x 12

Hinge Size		Gauge of Metal	Hole Count	Screw Size	
Inches	mm			Machine	Wood
5 x 4-1/2	127 x 114	0.134	8	1/2 x 12-24	1-1/4 x 12

Note: Additional sizes and hinges available. Contact Hager Customer Service for information.



## ELECTRIC HINGES

The electric hinge provides an easy means to monitor the opening as well as transferring power from the frame into the door.

Electric hinge modifications can be either exposed on the surface of the hinge or concealed in the hinge. When concealed, the modifications are not visible and normally go undetected by personnel using the openings.

All of the Hager Companies electric hinges have been tested through UL in order that our products can be used on fire-rated or labeled openings.

Another important point to remember, an electrically modified hinge is for **low voltage power transfer only (48 volts or under)**. Higher voltages are not allowed because of the potential dangers. Also a consideration is the amperage rating of the power transfer hinges. Hager's 18 gauge wires are rated for 50 volts AC/DC at 10 amps continuous. The maximum inrush is 20 AMPS for 4 seconds per wire. Hager 28 gauge wires include amperage ratings of 3.5 AMPS/continuous duty and 16.0 AMPS/intermittent duty (pulse).

Modifications are made to full mortise hinges. For other applications, consult Hager Engineering for availability.

It is recommended that the **CENTER HINGE LOCATION** be used with all electrically modified hinges.

Hager Companies recommends the use of a mortar box or jamb box in order to protect the wire terminations on the inside of the frame. If this box is not used, the grout that may be poured into the frame will destroy the wiring and usually void the warranty on the product.





## HINGE SELECTOR - FULL MORTISE & HALF MORTISE HINGES

Hinge Description	Full Mortise	Half Mortise
	Hollow Metal or Wood Door	Hollow Metal or Wood Door
	Hollow Metal or Wood Frame	Channel Iron Frame
Tri-Con Std. Wt. PB, Steel	700	
Tri-Con Std. Wt. PB, Brass/Stainless Steel	800	
Tri-Con Std. Wt. AB, Steel	AB700	AB701
Tri-Con Std. Wt. AB, Brass/Stainless Steel	AB800	AB801
Tri-Con Hvy. Wt. AB, Steel	AB750	AB751
Tri-Con Hvy. Wt. AB, Brass/Stainless Steel	AB850	AB851
Spring Hinge Std. Wt., Steel	1250	
Std. Wt., PB, Steel	1279	1129
Std. Wt., PB, Brass/Stainless Steel	1191	
2BB, Std. Wt., Steel	BB1279	BB1129
2BB, Std. Wt., Brass/Stainless Steel	BB1191	BB1109
4BB, Hvy Wt., Steel	BB1168	BB1138
4BB, Hvy Wt., Brass/Stainless Steel	BB1199	BB2098
3K/5K Anchor Hinge Steel, One Prong	AB7505/BB1160	
3K/5K Anchor Hinge Brass/Stainless Steel One Prong	AB8505/BB1190	
3K/5K Anchor Hinge Steel, Two Prong, Square Edge Door	AB7506/BB1162	
3K/5K Anchor Hinge Brass/Stainless Steel, Two Prong/Square Edge Door	AB8506/BB1192	
3K/5K Anchor Hinge Steel/Two Prong, Beveled Edge Door	AB7508/BB1166	
3K/5K Anchor Hinge Brass/Stainless Steel, Two Prong/Beveled Edge Door	AB8508/BB1196	
3K/5K Anchor Hinge Steel/One Long/One Short Prong/Square Edge Door	AB7507/BB1165	
3K/5K Anchor Hinge Brass/Stainless Steel/One Long/One Short Prong/Square Edge Door	AB8507/BB1195	
3K/5K Anchor Hinge Steel/One Long/One Short Prong/Beveled Edge Door	AB7509/BB1167	
3K/5K Anchor Hinge Brass/Stainless Steel/One Long/One Short Prong/Beveled Edge Door	AB8509/BB1197	
Bronze Pivot Hinge - Top	495	
Bronze Pivot Hinge - Intermediate	496	
Bronze Pivot Hinge - Bottom	497	
3K/5K Swing Clear/Std. Wt., BB Steel/Beveled Edge Door	AB7001/BB1260	BB1264
3K/5K Swing Clear/Std. Wt., BB Steel/Beveled Edge Door	AB7002/BB1261	BB1265
3K/5K Swing Clear/Hvy. Wt., BB Steel/Square Edge Door	AB7501/BB1262	AB7511
3K/5K Swing Clear/Hvy. Wt., BB Steel/ Beveled Edge Door	AB7502/BB1263	AB7512
3K/5K Swing Clear/Hvy. Wt., BB Steel		
3K/5K Std. Wt., PB, Wide Throw/Steel	700/1279	
3K/5K Std. Wt., PB, Wide Throw/Brass/Stainless Steel	800/1191	
3K/5K Std. Wt., AB, Wide Throw/Steel	AB700/BB1279	
3K/5K Std. Wt., AB, Wide Throw/Brass/Stainless Steel	AB800/BB1191	
3K/5K Hvy. Wt., AB, Wide Throw/Steel	AB750/BB1168	
3K/5K Hvy. Wt., AB, Wide Throw/Brass/Stainless Steel	AB850/BB1199	

For Hospital Tip, use prefix "HT" on above number. Hospital Tip hinges are available on all architectural hinges with the exception of anchor hinges.

Note: When ordering round corner hinges, please specify a radius of either 1/4" (6.4 mm) or 5/8" (15.9 mm). If radius is not specified, 1/4" (6.4 mm) will be supplied.

Note: For special requirements - In the event a particular hinge is not found to meet your requirements, please contact our Customer Service Department and provide Hager with the specific requirements. The Hager Technical Service Staff will prepare drawings for the appropriate application.



## HINGE SELECTOR - FULL SURFACE & HALF SURFACE HINGES

Hinge Description	Full Surface	Half Surface
	Composite or Tubular Steel Door	Composite or Wood Door
	Channel Iron Frame	Hollow Metal or Wood Frame
Tri-Con Std. Wt. PB, Steel		
Tri-Con Std. Wt. PB, Brass/Stainless Steel		
Tri-Con Std. Wt. AB, Steel	AB702	AB703
Tri-Con Std. Wt. AB, Brass/Stainless Steel	AB802	AB803
Tri-Con Hvy. Wt. AB, Steel	AB752	AB753
Tri-Con Hvy. Wt. AB, Brass/Stainless Steel	AB852	AB853
Spring Hinge Std. Wt., Steel		
Std. Wt., PB, Steel		1173
Std. Wt., PB, Brass/Stainless Steel		
2BB, Std. Wt., Steel	BB2171	BB1173
2BB, Std. Wt., Brass/Stainless Steel	BB2110	BB2112
4BB, Hvy Wt., Steel	BB2168/BB2169	BB1163
4BB, Hvy Wt., Brass/Stainless Steel	BB2108/BB2109	BB2113
3K/5K Anchor Hinge Steel, One Prong		
3K/5K Anchor Hinge Brass/Stainless Steel One Prong		
3K/5K Anchor Hinge Steel, Two Prong, Square Edge Door		
3K/5K Anchor Hinge Brass/Stainless Steel, Two Prong/Square Edge Door		
3K/5K Anchor Hinge Steel/Two Prong, Beveled Edge Door		
3K/5K Anchor Hinge Brass/Stainless Steel, Two Prong/Beveled Edge Door		
3K/5K Anchor Hinge Steel/One Long/One Short Prong/Square Edge Door		
3K/5K Anchor Hinge Brass/Stainless Steel/One Long/One Short Prong/Square Edge Door		
3K/5K Anchor Hinge Steel/One Long/One Short Prong/Beveled Edge Door		
3K/5K Anchor Hinge Brass/Stainless Steel/One Long/One Short Prong/Beveled Edge Door		
Bronze Pivot Hinge - Top		
Bronze Pivot Hinge - Intermediate		
Bronze Pivot Hinge - Bottom		
3K/5K Swing Clear/Std. Wt., BB Steel/Beveled Edge Door		
3K/5K Swing Clear/Std. Wt., BB Steel/Beveled Edge Door		
3K/5K Swing Clear/Hvy. Wt., BB Steel/Square Edge Door		
3K/5K Swing Clear/Hvy. Wt., BB Steel/ Beveled Edge Door		
3K/5K Swing Clear/Hvy. Wt., BB Steel	AB7523/BB1266	AB7534/BB1270
3K/5K Std. Wt., PB, Wide Throw/Steel		
3K/5K Std. Wt., PB, Wide Throw/Brass/Stainless Steel		
3K/5K Std. Wt., AB, Wide Throw/Steel		
3K/5K Std. Wt., AB, Wide Throw/Brass/Stainless Steel		
3K/5K Hvy. Wt., AB, Wide Throw/Steel		
3K/5K Hvy. Wt., AB, Wide Throw/Brass/Stainless Steel		

For Hospital Tip, use prefix "HT" on above number. Hospital Tip hinges are available on all architectural hinges with the exception of anchor hinges.  
 Note: When ordering round corner hinges, please specify a radius of either 1/4" (6.4 mm) or 5/8" (15.9 mm). If radius is not specified, 1/4" (6.4 mm) will be supplied.  
 Note: For special requirements - In the event a particular hinge is not found to meet your requirements, please contact our Customer Service Department and provide Hager with the specific requirements. The Hager Technical Service Staff will prepare drawings for the appropriate application.



## CONCEALED LEAF - FULL MORTISE

### TWO KNUCKLE HINGES



**920**  
**Plain Bearing - Standard Weight**  
 Steel with steel pin (ANSI A8133)

**AB920**  
**Concealed Anti-Friction Bearing - Standard Weight**  
 Steel with steel pin (ANSI A8112)

**AB923**  
**Concealed Anti-Friction Bearing - Standard Weight**

- Brass with stainless steel pin (ANSI A2112) or stainless steel with stainless steel pin (ANSI A5112)
- Handed
- With door closer use ball bearing hinge or anti-friction
- For use on medium weight doors or doors requiring medium frequency service

Hinge Size		Gauge of Metal	Hole Count	Screw Size	
Inches	mm			Machine	Wood
4-1/2 x 4	114 x 102	0.134	8	1/2 x 12-24	1-1/4 x 12
4-1/2 x 4-1/2	114 x 114	0.134	8	1/2 x 12-24	1-1/4 x 12



**AB930**  
**Concealed Anti-Friction Bearing - Heavy Weight**  
 Steel with steel pin (ANSI A8111)

**AB933**  
**Concealed Anti-Friction Bearing - Heavy Weight**

- Brass with stainless steel pin (ANSI A2111) or stainless steel with stainless steel pin (ANSI A5111)
- Handed
- For use on heavy weight doors or doors requiring high frequency service

Hinge Size		Gauge of Metal	Hole Count	Screw Size	
Inches	mm			Machine	Wood
4-1/2 x 4	114 x 102	0.180	8	1/2 x 12-24	1-1/4 x 12
4-1/2 x 4-1/2	114 x 114	0.180	8	1/2 x 12-24	1-1/4 x 12

### THREE KNUCKLE HINGES



**700**  
**Plain Bearing - Standard Weight**  
 Steel with steel pin (ANSI A8133)

**800**  
**Plain Bearing - Standard Weight**

- Brass with stainless steel pin (ANSI A2133) or stainless steel with stainless steel pin (ANSI A5133)
- Non-rising removable pin with flush pin and plug
- With door closer use ball bearing hinge
- For use on medium weight doors or doors requiring low frequency service



**AB700**  
**Concealed Anti-Friction Bearing - Standard Weight**  
 Steel with steel pin (ANSI A8112)

**AB800**  
**Concealed Anti-Friction Bearing - Standard Weight**

- Brass with stainless steel pin (ANSI A2112) or stainless steel with stainless steel pin (ANSI A5112)
- Non-rising removable pin with flush pin and plug
- AB800 available with SecureCoat® Lifetime finish (US3SC)
- For use on medium weight doors or doors requiring medium frequency service

Hinge Size		Gauge of Metal	Hole Count	Screw Size	
Inches	mm			Machine	Wood
3-1/2 x 3-1/2	89 x 89	0.119	6	1/2 x 10-24	1 x 9
4 x 4	102 x 102	0.129	8	1/2 x 12-24	1-1/4 x 12
4-1/2 x 4	114 x 102	0.134	8	1/2 x 12-24	1-1/4 x 12
4-1/2 x 4-1/2	114 x 114	0.134	8	1/2 x 12-24	1-1/4 x 12
5 x 4	127 x 102	0.145	8	1/2 x 12-24	1-1/4 x 12
5 x 4-1/2	127 x 114	0.145	8	1/2 x 12-24	1-1/4 x 12
5 x 5	127 x 127	0.145	8	1/2 x 12-24	1-1/4 x 12



## FULL MORTISE

### THREE KNUCKLE HINGES



**WTAB700**  
**Concealed Anti-Friction Bearing - Standard Weight - Wide Throw**  
 Steel with steel pin (ANSI A8112)

**WTAB800**  
**Concealed Anti-Friction Bearing - Standard Weight - Wide Throw**

- Brass with stainless steel pin (ANSI A2112) or stainless steel with stainless steel pin (ANSI A5112)
- For square edge doors. Consult Hager Tech Service for bevel application.
- Wide throw
- Non-rising removable pin with flush pin and plug
- For use on medium weight doors or doors requiring medium frequency service
- Note: Wide throw hinges will reduce the weight capacity. Consult Hager Tech Service.



**AB750**  
**Concealed Anti-Friction Bearing - Heavy Weight**  
 Steel with steel pin (ANSI A8111)

**AB850**  
**Concealed Anti-Friction Bearing - Heavy Weight**

- Brass with stainless steel pin (ANSI A2111) or stainless steel with stainless steel pin (ANSI A5111)
- Non-rising removable pin with flush pin and plug
- AB850 available with SecureCoat® Lifetime finish (US3SC)
- For use on heavy weight doors or doors requiring high frequency service

Hinge Size		Gauge of Metal	Hole Count	Screw Size	
Inches	mm			Machine	Wood
4-1/2 x 5	114 x 127	0.134	8	1/2 x 12-24	1-1/4 x 12
4-1/2 x 6	114 x 152	0.134	8	1/2 x 12-24	1-1/4 x 12
4-1/2 x 7	114 x 178	0.134	8	1/2 x 12-24	1-1/4 x 12
4-1/2 x 8	114 x 203	0.134	8	1/2 x 12-24	1-1/4 x 12
5 x 6	127 x 152	0.145	8	1/2 x 12-24	1-1/4 x 12
5 x 7	127 x 178	0.145	8	1/2 x 12-24	1-1/4 x 12
5 x 8	127 x 203	0.145	8	1/2 x 12-24	1-1/4 x 12

Hinge Size		Gauge of Metal	Hole Count	Screw Size	
Inches	mm			Machine	Wood
4-1/2 x 4-1/2	114 x 114	0.180	8	1/2 x 12-24	1-1/4 x 12
5 x 4-1/2	127 x 114	0.190	8	1/2 x 12-24	1-1/4 x 12
5 x 5	127 x 127	0.190	8	1/2 x 12-24	1-1/4 x 12
6 x 4-1/2	152 x 114	0.203	10	1/2 x 1/4-20	1-1/2 x 14
6 x 5	152 x 127	0.203	10	1/2 x 1/4-20	1-1/2 x 14
6 x 6	152 x 152	0.203	10	1/2 x 1/4-20	1-1/2 x 14

Note: Weight capacity diminishes the farther the pin is away from the door.





## FULL MORTISE

### THREE KNUCKLE HINGES



**WTAB750**  
**Concealed Anti-Friction Bearing - Heavy Weight - Wide Throw**  
 Steel with steel pin (ANSI A8111)

**WTAB850**  
**Concealed Anti-Friction Bearing - Heavy Weight - Wide Throw**

- Brass with stainless steel pin (ANSI A2111) or stainless steel with stainless steel pin (ANSI A5111)
- Wide throw
- Non-rising removable pin with flush pin and plug
- For use on heavy weight doors or doors requiring high frequency service

Hinge Size		Gauge of Metal	Hole Count	Screw Size	
Inches	mm			Machine	Wood
4-1/2 x 5	114 x 127	0.180	8	1/2 x 12-24	1-1/4 x 12
4-1/2 x 6	114 x 152	0.180	8	1/2 x 12-24	1-1/4 x 12
4-1/2 x 7	114 x 178	0.180	8	1/2 x 12-24	1-1/4 x 12
4-1/2 x 8	114 x 203	0.180	8	1/2 x 12-24	1-1/4 x 12
5 x 6	127 x 152	0.190	8	1/2 x 12-24	1-1/4 x 12
5 x 7	127 x 178	0.190	8	1/2 x 12-24	1-1/4 x 12
5 x 8	127 x 203	0.190	8	1/2 x 12-24	1-1/4 x 12

### FIVE KNUCKLE HINGES



**1191**  
**Plain Bearing - Standard Weight**  
 Brass with stainless steel pin (ANSI A2133) or stainless steel with stainless steel pin (ANSI A5133)

**1279**  
**Plain Bearing - Standard Weight**

- Steel with steel pin (ANSI A8133)
- Non-rising removable pin with button tip and plug
- Use ball bearing hinge when door closer is installed on door
- 3-1/2" x 3-1/2" (89 mm x 89 mm) available with reverse hole pattern
- For use on medium weight doors or doors requiring low frequency service

Hinge Size		Gauge of Metal	Hole Count	Screw Size	
Inches	mm			Machine	Wood
2 x 2	51 x 51	0.083	4	-	3/4 x 8
2-1/2 x 2-1/2	64 x 64	0.089	6	-	3/4 x 8
3 x 3	76 x 76	0.097	6	-	1 x 9
3-1/2 x 3-1/2	89 x 89	0.119	6	1/2 x 10-24	1 x 9
4 x 4	102 x 102	0.129	8	1/2 x 12-24	1-1/4 x 12
4-1/2 x 4	114 x 102	0.134	8	1/2 x 12-24	1-1/4 x 12
4-1/2 x 4-1/2	114 x 114	0.134	8	1/2 x 12-24	1-1/4 x 12
5 x 4	127 x 102	0.145	8	1/2 x 12-24	1-1/4 x 12
5 x 4-1/2	127 x 114	0.145	8	1/2 x 12-24	1-1/4 x 12
5 x 5	127 x 127	0.145	8	1/2 x 12-24	1-1/4 x 12
6 x 4-1/2	152 x 114	0.160	10	1/2 x 1/4-20	1-1/2 x 14
6 x 5	152 x 127	0.160	10	1/2 x 1/4-20	1-1/2 x 14
6 x 6	152 x 152	0.160	10	1/2 x 1/4-20	1-1/2 x 14



## FULL MORTISE

### FIVE KNUCKLE HINGES



**WT1191**  
**Plain Bearing - Standard Weight - Wide Throw**

Brass with stainless steel pin (ANSI A2133) or stainless steel with stainless steel pin (ANSI A5133)

**WT1279**  
**Plain Bearing - Standard Weight - Wide Throw**

- Steel with steel pin (ANSI A8133)
- Wide throw
- Non-rising removable pin with button tip and plug
- Use ball bearing hinge when door closer is installed on door
- For use on medium weight doors or doors requiring low frequency service
- Note: Wide throw hinges will reduce the weight capacity. Consult Hager Tech Service.

Hinge Size		Gauge of Metal	Hole Count	Screw Size	
Inches	mm			Machine	Wood
3-1/2 x 5	89 x 127	0.119	6	1/2 x 10-24	1 x 9
3-1/2 x 6	89 x 152	0.119	6	1/2 x 10-24	1 x 9
4 x 5	102 x 127	0.129	8	1/2 x 12-24	1-1/4 x 12
4 x 6	102 x 152	0.129	8	1/2 x 12-24	1-1/4 x 12
4 x 7	102 x 178	0.129	8	1/2 x 12-24	1-1/4 x 12
4-1/2 x 5	114 x 127	0.134	8	1/2 x 12-24	1-1/4 x 12
4-1/2 x 6	114 x 152	0.134	8	1/2 x 12-24	1-1/4 x 12
4-1/2 x 7	114 x 178	0.134	8	1/2 x 12-24	1-1/4 x 12
4-1/2 x 8	114 x 203	0.134	8	1/2 x 12-24	1-1/4 x 12
5 x 6	127 x 152	0.145	8	1/2 x 12-24	1-1/4 x 12
5 x 7	127 x 178	0.145	8	1/2 x 12-24	1-1/4 x 12
5 x 8	127 x 203	0.145	8	1/2 x 12-24	1-1/4 x 12



**CB1191**  
**Concealed Bearing - Standard Weight**

- Stainless steel with stainless steel pin (ANSI A5112) or brass
- Non-rising removable pin with button tip and plug

Hinge Size		Gauge of Metal	Hole Count	Screw Size	
Inches	mm			Machine	Wood
3-1/2 x 3-1/2	89 x 89	0.119	6	-	1 x 9
4 x 4	102 x 102	0.129	8	-	1-1/4 x 12
4-1/2 x 4	114 x 102	0.134	8	-	1-1/4 x 12
4-1/2 x 4-1/2	114 x 114	0.134	8	-	1-1/4 x 12
5 x 4	127 x 102	0.145	8	-	1-1/4 x 12
5 x 4-1/2	127 x 114	0.145	8	-	1-1/4 x 12
5 x 5	127 x 127	0.145	8	-	1-1/4 x 12
6 x 4-1/2	152 x 114	0.160	10	-	1-1/2 x 14
6 x 5	152 x 127	0.160	10	-	1-1/2 x 14
6 x 6	152 x 152	0.160	10	-	1-1/2 x 14





## FULL MORTISE

### FIVE KNUCKLE HINGES



**BB1191**  
**Ball Bearing - Standard Weight**  
 Brass with stainless steel pin (ANSI A2112) or stainless steel with stainless steel pin (ANSI A5112)

**BB1279**  
**Ball Bearing - Standard Weight**

- Steel with steel pin (ANSI A8112)
- Two ball bearings
- Non-rising removable pin with button tip and plug
- 3-1/2" x 3-1/2" (89 x 89 mm) BB1279 available with reversible hole pattern
- For use on medium weight doors or doors requiring medium frequency service



**WTBB1191**  
**Ball Bearing - Standard Weight - Wide Throw**  
 Brass with stainless steel pin (ANSI A2112) or stainless steel with stainless steel pin (ANSI A5112)

**WTBB1279**  
**Ball Bearing - Standard Weight - Wide Throw**

- Steel with steel pin (ANSI A8112)
- Wide throw
- Two ball bearings
- Non-rising removable pin with button tip and plug
- For use on medium weight doors or doors requiring medium frequency service

Hinge Size		Gauge of Metal	Hole Count	Screw Size	
Inches	mm			Machine	Wood
3-1/2 x 3-1/2	89 x 89	0.119	6	1/2 x 10-24	1 x 9
4 x 3-1/2	102 x 89	0.129	8	1/2 x 10-24	1-1/4 x 12
4 x 4	102 x 102	0.129	8	1/2 x 12-24	1-1/4 x 12
4-1/2 x 4	114 x 102	0.134	8	1/2 x 12-24	1-1/4 x 12
4-1/2 x 4-1/2	114 x 114	0.134	8	1/2 x 12-24	1-1/4 x 12
5 x 4	127 x 102	0.145	8	1/2 x 12-24	1-1/4 x 12
5 x 4-1/2	127 x 114	0.145	8	1/2 x 12-24	1-1/4 x 12
5 x 5	127 x 127	0.145	8	1/2 x 12-24	1-1/4 x 12
6 x 4-1/2	152 x 114	0.160	10	1/2 x 1/4-20	1-1/2 x 14
6 x 5	152 x 127	0.160	10	1/2 x 1/4-20	1-1/2 x 14
6 x 6	152 x 152	0.160	10	1/2 x 1/4-20	1-1/2 x 14

Hinge Size		Gauge of Metal	Hole Count	Screw Size	
Inches	mm			Machine	Wood
3-1/2 x 5	89 x 127	0.119	6	1/2 x 10-24	1 x 9
3-1/2 x 6	89 x 152	0.119	6	1/2 x 10-24	1 x 9
4 x 5	102 x 127	0.129	8	1/2 x 12-24	1-1/4 x 12
4 x 6	102 x 152	0.129	8	1/2 x 12-24	1-1/4 x 12
4 x 7	102 x 178	0.129	8	1/2 x 12-24	1-1/4 x 12
4-1/2 x 5	114 x 127	0.134	8	1/2 x 12-24	1-1/4 x 12
4-1/2 x 6	114 x 152	0.134	8	1/2 x 12-24	1-1/4 x 12
4-1/2 x 7	114 x 178	0.134	8	1/2 x 12-24	1-1/4 x 12
4-1/2 x 8	114 x 203	0.134	8	1/2 x 12-24	1-1/4 x 12
5 x 6	127 x 152	0.145	8	1/2 x 12-24	1-1/4 x 12
5 x 7	127 x 178	0.145	8	1/2 x 12-24	1-1/4 x 12
5 x 8	127 x 203	0.145	8	1/2 x 12-24	1-1/4 x 12

Note: Optional concealed bearings available, see page 5 for options.



## FULL MORTISE

### FIVE KNUCKLE HINGES



**BB1168**  
**Ball Bearing - Heavy Weight**  
 Steel with steel pin (ANSI A8111)

**BB1199**  
**Ball Bearing - Heavy Weight**

- Brass with stainless steel pin (ANSI A2111) or stainless steel with stainless steel pin (ANSI A5111)
- Four ball bearings
- Non-rising removable pin with button tip and plug
- For use on heavy weight doors or doors requiring high frequency service



**WTBB1168**  
**Ball Bearing - Heavy Weight - Wide Throw**  
 Steel with steel pin (ANSI A8111)

**WTBB1199**  
**Ball Bearing - Heavy Weight - Wide Throw**

- Brass with stainless steel pin (ANSI A2111) or stainless steel with stainless steel pin (ANSI A5111)
- Wide throw
- Four ball bearings
- Non-rising removable pin with button tip and plug
- For use on heavy weight doors or doors requiring high frequency service

Hinge Size		Gauge of Metal	Hole Count	Screw Size	
Inches	mm			Machine	Wood
4-1/2 x 4	114 x 102	0.180	8	1/2 x 12-24	1-1/4 x 12
4-1/2 x 4-1/2	114 x 114	0.180	8	1/2 x 12-24	1-1/4 x 12
5 x 4	127 x 102	0.190	8	1/2 x 12-24	1-1/4 x 12
5 x 4-1/2	127 x 114	0.190	8	1/2 x 12-24	1-1/4 x 12
5 x 5	127 x 127	0.190	8	1/2 x 12-24	1-1/4 x 12
6 x 4-1/2	152 x 114	0.203	10	1/2 x 1/4-20	1-1/2 x 14
6 x 5	152 x 127	0.203	10	1/2 x 1/4-20	1-1/2 x 14
6 x 6	152 x 152	0.203	10	1/2 x 1/4-20	1-1/2 x 14
8 x 6	203 x 152	0.203	16	1/2 x 1/4-20	1-1/2 x 14
8 x 8	203 x 203	0.203	16	1/2 x 1/4-20	1-1/2 x 14

Hinge Size		Gauge of Metal	Hole Count	Screw Size	
Inches	mm			Machine	Wood
4-1/2 x 5	114 x 127	0.180	8	1/2 x 12-24	1-1/4 x 12
4-1/2 x 6	114 x 152	0.180	8	1/2 x 12-24	1-1/4 x 12
4-1/2 x 7	114 x 178	0.180	8	1/2 x 12-24	1-1/4 x 12
4-1/2 x 8	114 x 203	0.180	8	1/2 x 12-24	1-1/4 x 12
5 x 6	127 x 152	0.190	8	1/2 x 12-24	1-1/4 x 12
5 x 7	127 x 178	0.190	8	1/2 x 12-24	1-1/4 x 12
5 x 8	127 x 203	0.190	8	1/2 x 12-24	1-1/4 x 12

Note: Optional concealed bearings available, see page 5 for options.





## FULL MORTISE - CONCEALED ELECTRIC

### EXPOSED ELECTRIC MODIFICATIONS

The following exposed electric modifications are available on our architectural grade ball bearing and anti-friction bearing hinges. To order a hinge with exposed electric modification, please add the modification code to the product number (for example, BB1279 E2).



#### E2

##### Electric Contact

- Three or five knuckle
- Available on architectural grade ball bearing and anti-friction bearing
- Two contacts minimum required to transfer electrical current
- Design includes insulated copper contacts
- Furnished with non-removable pins



#### E2/E1S

##### Electric Contact/Switch

- Three or five knuckle
- Available on architectural grade ball bearing and anti-friction bearing
- Single pole, double throw switch
- Design includes insulated copper contacts
- Furnished with non-removable pins

Hinge Size		Contacts
Inches	mm	
4 x 4	102 x 102	2 or 3
4-1/2 x 4-1/2	114 x 114	2, 3, or 4
5 x 5	127 x 127	2, 3, or 4

Contact Maximum Electrical Rating		
Volts	Amperes	
48 VDC	3.5 amps	CONTINUOUS
	16.0 amps	PULSE

Hinge Size	
Inches	mm
4 x 4	102 x 102
4-1/2 x 4-1/2	114 x 114
5 x 5	127 x 127

Contact Maximum Electrical Rating		
Volts	Amperes	
48 VDC	3.5 amps	CONTINUOUS
	16.0 amps	PULSE
Switch Maximum Electrical Rating		
24 VDC @ .250 amps		



#### E1S

##### Electric Switch

- Three or five knuckle
- Available on architectural grade ball bearing and anti-friction bearing
- Single pole, double throw switch
- Furnished with non-removable pins

Hinge Size	
Inches	mm
4 x 4	102 x 102
4-1/2 x 4-1/2	114 x 114
5 x 5	127 x 127

Switch Maximum Electrical Rating
24 VDC @ .250 amps



## FULL MORTISE - CONCEALED ELECTRIC

### CONCEALED ELECTRIC MODIFICATIONS

The following concealed electric modifications are available on our architectural grade ball bearing and anti-friction bearing hinges. To order a hinge with concealed electric modification, please add the modification code to the product number (for example, BB1279 EMN).



#### EMN

##### Electric Monitor Only

- Three or five knuckle
- Available on architectural grade ball bearing and anti-friction bearing
- Available in steel, brass, or stainless steel
- 28 gauge wire standard
- Standard size available 4" (102 mm) through 8" (203 mm)
- Hinge pins are not field removable - NRP variation is not available
- Monitoring capability only
- Concealed subminiature snap action, SPDT switch
- Adjustment feature for a wide range of switch sensitivity
- Preset switching circuit
- For open loop secure, closed loop secure or single pole double throw (SPDT)

#### Switch Maximum Electrical Rating

30 VDC @ .500 amps



#### \*ETW

##### Electric Through-Wire Only

- Two, three or five knuckle
- Available on architectural grade ball bearing and anti-friction bearing
- Available in steel, brass, or stainless steel
- 18 and 28 gauge wire
- Standard size available 4" (102 mm) through 8" (203 mm)
- Hinge pins are not field removable - NRP variation is not available
- Low voltage electric current transfer capability only
- 4, 8, or 12 continuous electrical conductors
- For 6 wire, use 8
- For 10 wire, use 12

#### Wire Maximum Electrical Rating

Volts	Amperes	
48 VDC	3.5 amps	CONTINUOUS
	16.0 amps	PULSE



#### ETM

##### Electric Through-Wire with Monitoring

- Three or five knuckle
- Available on architectural grade ball bearing and anti-friction bearing
- Available in steel, brass, or stainless steel
- 18 and 28 gauge wire
- Standard size available 4" (102 mm) through 8" (203 mm)
- Hinge pins are not field removable - NRP variation is not available
- Both continuous electric conductors and monitoring capability
- Concealed monitor switch and 4, 8 or 10 continuous electrical conductors
- Adjustment feature for a wide range of switch sensitivity
- For open loop secure, closed loop secure or single pole double throw (SPDT)

#### Contact Maximum Electrical Rating

Volts	Amperes	
48 VDC	3.5 amps	CONTINUOUS
	16.0 amps	PULSE

#### Switch Maximum Electrical Rating

30 VDC @ .500 amps

\*Quick Connect Option (QC) available with all ETW and ETM hinges - must specify.





## FULL MORTISE - CONCEALED ELECTRIC

### CONCEALED AIR TRANSFER

The following hinges are available with a concealed air transfer (ATH) modification. They are available on architectural grade ball bearing and anti-friction bearing full mortise. Please note:

- ATH modification is for doors that require the transfer of compressed air.
- The hinges with ATH modification available use 5/32" (4 mm) plastic air tubing, have quick-connect fittings, and are capable of transferring 80-100 PSI through the air tubing.
- Steel or stainless steel hinges are acceptable for use on labeled or fire-rated doors.
- Hinge pins are not field removable.
- NRP and safety stud are not available.



### 430 Mortar Box

- Galvanized steel 0.040 (1 mm)
- Dimensions - 9" (2.29 mm) length with tabs, 7" (1.78 mm) inside, 1-3/4" x 1-3/4" (45 mm x 45 mm) inside dimension
- Removable back for servicing
- Serves as mortar shield
- Top and bottom knockouts for standard conduit fittings
- Fits hinge reinforcements for 4-1/2" (114 mm) or 5" (127 mm) architectural grade hinges



**AB700**  
Standard Weight  
Steel



**AB800**  
Standard Weight  
Stainless steel, brass



**AB750**  
Heavy Weight  
Steel



**AB850**  
Heavy Weight  
Stainless steel, brass



**BB1191**  
Standard Weight  
Stainless steel, brass

**BB1279**  
Standard Weight  
Steel

**BB1168**  
Heavy Weight  
Steel

**BB1199**  
Heavy Weight  
Stainless steel, brass

Hinge Size	
Inches	mm
4-1/2 x 4	112 x 102
4-1/2 x 4-1/2	114 x 114
5 x 4	127 x 102
5 x 4-1/2	127 x 114
5 x 5	127 x 127



## FULL MORTISE - SPRING

### SINGLE ACTING

The following single acting spring hinges are for automatic closing of doors, please note:

- 1150 is not available in 3-1/2" x 3-1/2" (89 mm x 89 mm) and 4" x 4" (102 mm x 102 mm) sizes.
- 1250 is available with raised barrel for square edge or beveled doors.
- 1250 UL approved for use on 4' 0" x 8' 0" (1219 mm x 2438 mm) doors. 3 springs/one BB for 8' door.
- For maximum versatility, use all spring hinges or a combination of spring and ball bearing hinges. Do not use plain bearing hinges.
- Full spring tension may not be required on all hinges.
- Strong wind conditions, drafts, carpeting drag, twisted/misaligned frames, or weatherstripping on doors may require additional spring hinges. Available with HT - voids UL. Available with RBB/RBS - UL approved.



#### 1150

##### Square Corner

Stainless steel with stainless steel components (ANSI K51071F)

#### 1151

##### 1/4" Radius

Stainless steel with stainless steel components (ANSI K51071F)



#### 1152

##### 5/8" Radius

Stainless steel with stainless steel components (ANSI K51071F)

#### 1250

##### Square Corner

Steel with steel components (ANSI K81071F)

#### 1251

##### 1/4" Radius

Steel with steel components (ANSI K81071F)

#### 1252

##### 5/8" Radius

Steel with steel components (ANSI K81071F)

#### 1255

##### Square Corner Set

Steel with steel components (ANSI K81071F)  
Two (2) each 1250 and one (1) each AB700

#### 1256

##### Square Corner Set

Steel with steel components (ANSI K81071F)  
Two (2) each 1250 and one (1) each BB1279

Hinge Size		Gauge of Metal	Hole Count	Screw Size	
Inches	mm			Machine	Wood
3-1/2 x 3-1/2	89 x 89	0.134	6	1/2 x 10-24	1 x 9
4 x 4	102 x 102	0.134	8	1/2 x 12-24	1-1/4 x 12
4-1/2 x 4	114 x 102	0.134	8	1/2 x 12-24	1-1/4 x 12
4-1/2 x 4-1/2	114 x 114	0.134	8	1/2 x 12-24	1-1/4 x 12

Series	Size	Recommended Max Door Weight (lbs)	Spring Hinge	Ball Bearing Hinge
For use on 1-3/8" (35 mm) door				
1250	3-1/2 x 3-1/2	40	1	2
1250	3-1/2 x 3-1/2	70	2	1
1250	3-1/2 x 4-1/2	90	3	-
For use on 1-3/4" (45 mm) door				
1250	4 x 4	60	1	2
1250	4 x 4	85	2	1
1250	4 x 4	110	3	-
1150	4-1/2 x 4, 4-1/2 x 4-1/2	70	1	2
1150	4-1/2 x 4, 4-1/2 x 4-1/2	115	2	1
1150	4-1/2 x 4, 4-1/2 x 4-1/2	150	3	-
1250	4-1/2 x 4, 4-1/2 x 4-1/2	70	1	2
1250	4-1/2 x 4, 4-1/2 x 4-1/2	115	2	1
1250	4-1/2 x 4, 4-1/2 x 4-1/2	150	3	-
1255	4-1/2 x 4-1/2	115	2	1
1256	4-1/2 x 4-1/2	115	2	1







## FULL MORTISE - SPRING

### REVERSE ACTION - SINGLE ACTING

The following reverse action, single acting spring hinges are for automatic opening of door, please note:

- For maximum versatility, use all spring hinges or a combination of spring and ball bearing hinges. Do not use plain bearing hinges.
- Full spring tension may not be required on all hinges.
- Strong wind conditions, drafts, carpeting drag, twisted/misaligned frames, or weatherstripping on doors may require additional spring hinges.



**1257**  
**Square Corner**  
Steel (ANSI K81071)

**1258**  
**1/4" Radius**  
Steel (ANSI K81071)

**1259**  
**5/8" Radius**  
Steel (ANSI K81071)

Hinge Size		Gauge of Metal	Hole Count	Screw Size	
Inches	mm			Machine	Wood
3-1/2 x 3-1/2	89 x 89	0.134	6	1/2 x 10-24	1 x 9
4 x 4	102 x 102	0.134	8	1/2 x 12-24	1-1/4 x 12
4-1/2 x 4	114 x 102	0.134	8	1/2 x 12-24	1-1/4 x 12
4-1/2 x 4-1/2	114 x 114	0.134	8	1/2 x 12-24	1-1/4 x 12

Size	Recommended Max Door Weight (lbs)	Spring Hinge	Ball Bearing Hinge
<b>For use on 1-3/8" (35 mm) door</b>			
3-1/2 x 3-1/2	40	1	2
3-1/2 x 3-1/2	70	2	1
3-1/2 x 3-1/2	90	3	-
<b>For use on 1-3/4" (45 mm) door</b>			
4 x 4	60	1	2
4 x 4	85	2	1
4 x 4	110	3	-
4-1/2 x 4, 4-1/2 x 4-1/2	70	1	2
4-1/2 x 4, 4-1/2 x 4-1/2	115	2	1
4-1/2 x 4, 4-1/2 x 4-1/2	150	3	-

### SWING CLEAR

The following swing clear spring hinge is for automatic closing of door. It provides the features of both a swing clear hinge and a spring hinge. It meets codes for hotels, motels, institutions, and commercial buildings. Please note:

- For maximum versatility, use all spring hinges or a combination of spring and ball bearing hinges. Do not use plain bearing hinges.
- Full spring tension may not be required on all hinges.
- Strong wind conditions, drafts, carpeting drag, twisted/misaligned frames, or weatherstripping on doors may require additional spring hinges.



**1267**  
**Square Corner**  
• Steel with steel components (ANSI K81071F)  
• For square edge door. Use in conjunction with AB7001 or BB1260



Hinge Size		Gauge of Metal	Hole Count	Screw Size	
Inches	mm			Machine	Wood
4-1/2 x 4-1/2	114 x 114	0.134	8	1/2 x 12-24	1-1/4 x 12



## FULL MORTISE - ECCO

### FIVE KNUCKLE



**EC1100 | EC1100NRP**  
**Plain Bearing - Standard Weight**  
 Steel with steel pin (ANSI A8133)

**EC1101**  
**Plain Bearing - Standard Weight**

- Stainless steel with stainless steel pin (ANSI A5133) or brass with stainless steel pin (ANSI A2133)
- Non-rising removable pin with button tip and plug
- Use ball bearing hinge when a door closer is installed on the door
- For use on medium weight doors or doors requiring low frequency service

Hinge Size		Gauge of Metal	Hole Count	Screw Size	
Inches	mm			Machine	Wood
4-1/2 x 4	114 x 102	0.134	8	1/2 x 12-24	1-1/4 x 12
4-1/2 x 4-1/2	114 x 114	0.134	8	1/2 x 12-24	1-1/4 x 12



**ECRC1100**  
**Plain Bearing - Standard Weight**

- Steel with steel pin (ANSI A8133)
- Non-rising removable pin with button tip and plug
- Use ball bearing hinge when a door closer is installed on the door
- Round corner with 1/4" (6 mm) radius standard
- For use on medium weight doors or doors requiring low frequency service

Hinge Size		Gauge of Metal	Hole Count	Screw Size	
Inches	mm			Machine	Wood
4 x 4	102 x 102	0.129	8	1/2 x 12-24	1-1/4 x 12



**ECBB1100 | ECBB1100NRP**  
**Ball Bearing - Standard Weight**  
 Steel with steel pin (ANSI A8112)

**ECBB1101 | ECBB1101NRP**  
**Ball Bearing - Standard Weight**

- Brass with stainless steel pin (ANSI A2112) or 304 stainless steel with stainless steel pin (ANSI A5112)
- Two ball bearings
- Non-rising removable pin with button tip and plug
- ECBB1101 and ECBB1101NRP only available in 4-1/2" x 4-1/2" (114 mm x 114 mm)
- For use on medium weight doors or doors requiring medium frequency service
- 304 stainless steel standard
- **316 stainless steel available**

Hinge Size		Gauge of Metal	Hole Count	Screw Size	
Inches	mm			Machine	Wood
4-1/2 x 4	114 x 102	0.134	8	1/2 x 12-24	1-1/4 x 12
4-1/2 x 4-1/2	114 x 114	0.134	8	1/2 x 12-24	1-1/4 x 12



**ECRCBB1100**  
**Ball Bearing - Standard Weight**

- Steel with steel pin (ANSI A8112)
- Two ball bearings
- Non-rising removable pin with button tip and plug
- Round corner with 1/4" (6 mm) radius standard
- For use on medium weight doors or doors requiring medium frequency service

Hinge Size		Gauge of Metal	Hole Count	Screw Size	
Inches	mm			Machine	Wood
4 x 4	102 x 102	0.129	8	1/2 x 12-24	1-1/4 x 12





## FULL MORTISE - ECCO

### FIVE KNUCKLE



#### **ECBB1102 | ECBB1102NRP**

##### **Ball Bearing - Heavy Weight**

Steel with steel pin (ANSI A8111)

#### **ECBB1103 | ECBB1103NRP**

##### **Ball Bearing - Heavy Weight**

- Brass with stainless steel pin (ANSI A2111) or 304 stainless steel with stainless steel pin (ANSI A5111)
- Four (4) ball bearings
- Non-rising removable pin with flush pin and plug
- ECBB1102NRP and ECBB1103NRP are the same as ECBB1102 and ECBB1103, but with a non-removable pin
- For use on heavy weight doors or doors requiring high frequency service
- 304 stainless steel standard
- **316 stainless steel available**

Hinge Size		Gauge of Metal	Hole Count	Screw Size	
Inches	mm			Machine	Wood
4-1/2 x 4-1/2	114 x 114	0.180	8	1/2 x 12-24	1-1/4 x 12
5 x 4-1/2	127 x 114	0.190	8	1/2 x 12-24	1-1/4 x 12

### SPRING HINGE

The following ECCO single acting spring hinge is for automatic closing of door. Please note:

- For use on 1-3/4" (45 mm) doors
- For maximum versatility, use all spring hinges or a combination of spring and ball bearing hinges. Do not use plain bearing hinges.
- Full spring tension may not be required on all hinges.
- Strong wind conditions, drafts, carpeting drag, twisted/misaligned frames, or weatherstripping on doors may require additional spring hinges
- UL approved for 4' x 8' door
- Three (3) spring hinges and one (1) ball bearing hinge required for labeled openings



#### **EC1105**

##### **Square Corner**

Steel (ANSI K81071F)



Hinge Size		Gauge of Metal	Hole Count	Screw Size	
Inches	mm			Machine	Wood
4-1/2 x 4	114 x 102	0.134	8	1/2 x 12-24	1-1/4 x 12
4-1/2 x 4-1/2	114 x 114	0.134	8	1/2 x 12-24	1-1/4 x 12

Size	Recommended Max Door Weight (lbs)	Spring Hinge	Ball Bearing Hinge
4-1/2 x 4, 4-1/2 x 4-1/2	70	1	2
4-1/2 x 4, 4-1/2 x 4-1/2	115	2	1
4-1/2 x 4, 4-1/2 x 4-1/2	150	3	-



# HALF MORTISE

## THREE KNUCKLE HINGES



**AB701**  
**Concealed Anti-Friction Bearing - Standard Weight**  
 Steel with steel pin (ANSI A8212)

**AB801**  
**Concealed Anti-Friction Bearing - Standard Weight**

- Brass with stainless steel pin (ANSI A2212) or stainless steel with stainless steel pin (ANSI A5212)
- Non-rising removable pin with flush pin and plug
- Reversible
- For use on medium weight hollow metal doors with channel iron frames requiring medium frequency service



**AB751**  
**Concealed Anti-Friction Bearing - Heavy Weight**  
 Steel with steel pin (ANSI A8211)

**AB851**  
**Concealed Anti-Friction Bearing - Heavy Weight**

- Brass with stainless steel pin (ANSI A2211) or stainless steel with stainless steel pin (ANSI A5211)
- Non-rising removable pin with flush pin and plug
- Reversible
- For use on heavy weight hollow metal doors with channel iron frames requiring high frequency service

Hinge Size		Gauge of Metal	Hole Count	Machine Screw Size	
Inches	mm			Door Leaf	Jamb Leaf
4-1/2	114	0.134	7	1/2 x 12-24 FH	1/2 x 12-24 OH
5	127	0.145	8	1/2 x 12-24 FH	1/2 x 12-24 OH

Hinge Size		Door Leaf Width "A"		Jamb Leaf Width "B"		Jamb Leaf Offset "C"	
Inches	mm	Inches	mm	Inches	mm	Inches	mm
4-1/2	114	2	51	1-1/2	38	3/8	10
5	127	2	51	1-1/2	38	3/8	10

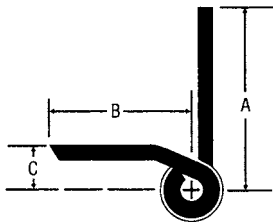

Hinge Size		Gauge of Metal	Hole Count	Machine Screw Size	
Inches	mm			Door Leaf	Jamb Leaf
4-1/2	114	0.180	7	1/2 x 12-24 FH	1/2 x 12-24 OH
5	127	0.190	8	1/2 x 12-24 FH	1/2 x 12-24 OH
6+	152	0.203* 0.190*	9	1/2 x 1/4-20 FH	1/2 x 1/4-20 OH

Hinge Size		Door Leaf Width "A"		Jamb Leaf Width "B"		Jamb Leaf Offset "C"	
Inches	mm	Inches	mm	Inches	mm	Inches	mm
4-1/2	114	2-1/16	53	1-1/2	38	7/16	11
5	127	2-1/16	53	1-1/2	38	7/16	11
6 x 1-3/4+	152	2-1/8	54	1-1/2	38	1/2	12.5

† Door thickness must be specified.  
 \* 0.203 for brass and steel. 0.190 for stainless steel.



## HALF MORTISE

### FIVE KNUCKLE HINGES



#### 1129

##### Plain Bearing - Standard Weight

- Steel with steel pin (ANSI A8233)
- Non-rising removable pin with button tip and plug
- Reversible
- Beveled surface leaf
- Not for use with door closer
- For use on medium weight hollow metal doors with channel iron frames requiring low frequency service

Hinge Size		Gauge of Metal	Hole Count	Machine Screw Size	
Inches	mm			Door Leaf	Jamb Leaf
4-1/2	114	0.134	7	1/2 x 12-24 FH	1/2 x 12-24 OH

Hinge Size		Door Leaf Width "A"		Jamb Leaf Width "B"		Jamb Leaf Offset "C"	
Inches	mm	Inches	mm	Inches	mm	Inches	mm
4-1/2	114	2	51	1-1/2	38	3/8	10



#### BB1138

##### Ball Bearing - Heavy Weight

Steel with steel pin (ANSI A8211)

#### BB2098

##### Ball Bearing - Heavy Weight

- Brass with stainless steel pin (ANSI A2211) or stainless steel with stainless steel pin (ANSI A5211)
- Four ball bearings
- Non-rising removable pin with button tip and plug
- Reversible
- Beveled surface leaf
- For use on heavy weight hollow metal doors with channel iron frames requiring high frequency service

Hinge Size		Gauge of Metal	Hole Count	Machine Screw Size	
Inches	mm			Door Leaf	Jamb Leaf
4-1/2	114	0.180	7	1/2 x 12-24 FH	1/2 x 12-24 OH
5	127	0.190	8	1/2 x 12-24 FH	1/2 x 12-24 OH
6+	152	0.203* 0.190*	9	1/2 x 1/4-20 FH	1/2 x 1/4-20 OH

Hinge Size		Door Leaf Width "A"		Jamb Leaf Width "B"		Jamb Leaf Offset "C"	
Inches	mm	Inches	mm	Inches	mm	Inches	mm
4-1/2	114	2-1/16	53	1-1/2	38	7/16	11
5	127	2-1/16	53	1-1/2	38	7/16	11
6 x 1-3/4+	152	2-1/8	54	1-1/2	38	1/2	12.5



#### BB1109

##### Ball Bearing - Standard Weight

Brass with stainless steel pin (ANSI A2212) or stainless steel with stainless steel pin (ANSI A5212)

#### BB1129

##### Ball Bearing - Standard Weight

- Steel with steel pin (ANSI A8212)
- Two ball bearings
- Non-rising removable pin with button tip and plug
- Reversible
- Beveled surface leaf
- For use on medium weight hollow metal doors with channel iron frames requiring medium frequency service

Hinge Size		Gauge of Metal	Hole Count	Machine Screw Size	
Inches	mm			Door Leaf	Jamb Leaf
4-1/2	114	0.134	7	1/2 x 12-24 FH	1/2 x 12-24 OH
5	127	0.145	8	1/2 x 12-24 FH	1/2 x 12-24 OH

Hinge Size		Door Leaf Width "A"		Jamb Leaf Width "B"		Jamb Leaf Offset "C"	
Inches	mm	Inches	mm	Inches	mm	Inches	mm
4-1/2	114	2	51	1-1/2	38	3/8	10
5	127	2	51	1-1/2	38	3/8	10

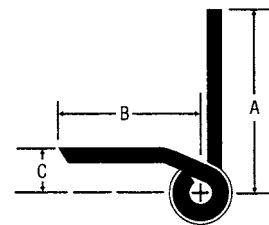

+ Door thickness must be specified.

\* 0.203 for brass and steel. 0.190 for stainless steel.





## FULL SURFACE

### THREE KNUCKLE HINGES



**AB702**  
**Concealed Anti-Friction Bearing - Standard Weight**  
 Steel with steel pin (ANSI A8312)

**AB802**  
**Concealed Anti-Friction Bearing - Standard Weight**

- Brass with stainless steel pin (ANSI A2312) or stainless steel with stainless steel pin (ANSI A5312)
- Thru-bolts and grommets for wood door applications
- Non-rising removable pin with flush pin and plug
- Reversible
- Beveled surface leaves
- For use on medium weight tubular steel doors with channel iron frames requiring medium frequency service



**AB752**  
**Concealed Anti-Friction Bearing - Heavy Weight**  
 Steel with steel pin (ANSI A8311)

**AB852**  
**Concealed Anti-Friction Bearing - Heavy Weight**

- Brass with stainless steel pin (ANSI A2311) or stainless steel with stainless steel pin (ANSI A5311)
- Thru-bolts and grommets for wood door applications
- Non-rising removable pin with flush pin and plug
- Reversible
- Beveled surface leaves
- For use on heavy weight hollow metal doors with channel iron frames requiring high frequency service

Hinge Size		Gauge of Metal	Hole Count	Machine Screw Size	
Inches	mm			Door Leaf	Jamb Leaf
4-1/2	114	0.134	6	2 x 1/4-20 OH	1/2 x 12-24 OH
5	127	0.145	8	2 x 1/4-20 OH	1/2 x 12-24 OH

Hinge Size		Door Leaf Width "A"		Jamb Leaf Width "B"		Jamb Leaf Offset "C"		Jamb Leaf Offset "D"	
Inches	mm	Inches	mm	Inches	mm	Inches	mm	Inches	mm
4-1/2	114	2-9/16	65	1-1/2	38	1/2	12.5	3/8	10
5	127	2-7/8	73	1-1/2	38	1/2	12.5	3/8	10

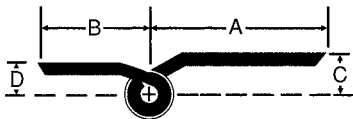

Hinge Size		Gauge of Metal	Hole Count	Machine Screw Size	
Inches	mm			Door Leaf	Jamb Leaf
4-1/2	114	0.180	6	2 x 1/4-20 OH	1/2 x 12-24 OH
5	127	0.190	8	2 x 1/4-20 OH	1/2 x 12-24 OH
6+	152	0.203* 0.190*	9	2 x 1/4-20 OH	1/2 x 12-20 OH

Hinge Size		Door Leaf Width "A"		Jamb Leaf Width "B"		Jamb Leaf Offset "C"		Jamb Leaf Offset "D"	
Inches	mm	Inches	mm	Inches	mm	Inches	mm	Inches	mm
4-1/2	114	2-9/16	65	1-1/2	38	9/16	14	7/16	11
5	127	2-7/8	73	1-1/2	38	9/16	14	7/16	11
6+	152	3-1/4	83	1-1/2	38	5/8	15	1/2	12.5

+ Door thickness must be specified.  
 \* 0.203 for brass and steel. 0.190 for stainless steel.



## FULL SURFACE

### FIVE KNUCKLE HINGES



#### BB2108

##### Ball Bearing - Heavy Weight

Brass with stainless steel pin (ANSI A2361) or stainless steel with stainless steel pin (ANSI A5361)

#### BB2168

##### Ball Bearing - Heavy Weight

Steel with steel pin (ANSI A8361)

- Four ball bearings
- Thru-bolts and grommets for wood door applications
- Non-rising removable pin with button tip and plug
- Reversible
- Beveled surface leaves
- For use on tubular steel doors with channel iron frames requiring high frequency service



#### BB2109

##### Ball Bearing - Heavy Weight

Brass with stainless steel pin (ANSI A2311) or stainless steel with stainless steel pin (ANSI A5311)

#### BB2169

##### Ball Bearing - Heavy Weight

Steel with steel pin (ANSI A8311)

- Four ball bearings
- Thru-bolts and grommets for wood door applications
- Non-rising removable pin with button tip and plug
- Reversible
- Beveled surface leaves
- For use on heavy hollow metal or wood composite doors with channel iron frames requiring high frequency service

Hinge Size		Gauge of Metal	Hole Count	Machine Screw Size	
Inches	mm			Door Leaf	Jamb Leaf
4-1/2	114	0.180	8	2 x 1/4-20 OH	1/2 x 1/4-20 OH
5	127	0.190	8	2 x 1/4-20 OH	1/2 x 1/4-20 OH
6+	152	0.203* 0.190*	8	2 x 1/4-20 OH	1/2 x 1/4-20 OH

Hinge Size		Gauge of Metal	Hole Count	Machine Screw Size	
Inches	mm			Door Leaf	Jamb Leaf
4-1/2	114	0.180	6	2 x 1/4-20 OH	1/2 x 12-24 OH
5	127	0.190	8	2 x 1/4-20 OH	1/2 x 12-24 OH
6+	152	0.203* 0.190*	9	2 x 1/4-20 OH	1/2 x 12-24 OH

Hinge Size		Door Leaf Width "A"		Jamb Leaf Width "B"		Jamb Leaf Offset "C"		Jamb Leaf Offset "D"	
Inches	mm	Inches	mm	Inches	mm	Inches	mm	Inches	mm
4-1/2	114	2	51	1-1/2	38	9/16	14	7/16	11
5	127	2-5/16	59	1-1/2	38	9/16	14	7/16	11
6+	152	2-3/8	60	1-1/2	38	5/8	15	1/2	12.5

Hinge Size		Door Leaf Width "A"		Jamb Leaf Width "B"		Jamb Leaf Offset "C"		Jamb Leaf Offset "D"	
Inches	mm	Inches	mm	Inches	mm	Inches	mm	Inches	mm
4-1/2	114	2-9/16	65	1-1/2	38	9/16	14	7/16	11
5	127	2-7/8	73	1-1/2	38	9/16	14	7/16	11
6+	152	3-1/4	83	1-1/2	38	5/8	15	1/2	12.5

+ Door thickness must be specified.

\* 0.203 for brass and steel. 0.190 for stainless steel.

+ Door thickness must be specified.

\* 0.203 for brass and steel. 0.190 for stainless steel.

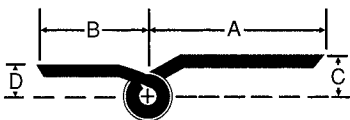



## FULL SURFACE

### FIVE KNUCKLE HINGES



#### BB2110

**Ball Bearing - Standard Weight**  
Brass with stainless steel pin (ANSI A2312) or stainless steel with stainless steel pin (ANSI A5312)

#### BB2171

**Ball Bearing - Standard Weight**

- Steel with steel pin (ANSI A8312)
- Two ball bearings
- Thru-bolts and grommets for wood door applications
- Non-rising removable pin with button top and plug
- Reversible
- Beveled surface leaves
- For use on medium weight hollow metal or wood composite doors with channel iron frames requiring medium frequency service

Hinge Size		Gauge of Metal	Hole Count	Machine Screw Size	
Inches	mm			Door Leaf	Jamb Leaf
4-1/2	114	0.134	6	2 x 1/4-20 OH	1/2 x 12-24 OH
5	127	0.145	8	2 x 1/4-20 OH	1/2 x 12-24 OH

Hinge Size		Door Leaf Width "A"		Jamb Leaf Width "B"		Jamb Leaf Offset "C"		Jamb Leaf Offset "D"	
Inches	mm	Inches	mm	Inches	mm	Inches	mm	Inches	mm
4-1/2	114	2-9/16	65	1-1/2	38	1/2	12.5	3/8	10
5	127	2-7/8	73	1-1/2	38	1/2	12.5	3/8	10

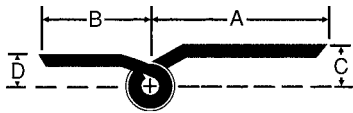

### WELDING HINGES



#### 1850-LP

**Loose Oval Head Pin Plain Bearing - Heavy Weight**

- Steel with steel pin
- Flat surface with no swage
- No holes
- Square corners
- Loose pin

Hinge Size		Gauge of Metal	Pin Diameter	Recommended Max Door Weight (lbs)
Inches	mm			
6 x 6	152 x 152	0.203	0.500	230

### WELDING HINGES



#### 1850

**Riveted Pin Plain Bearing - Heavy Weight**

- Steel with steel pin
- Flat surface with no swage
- No holes
- Square corners
- Fast riveted pin
- Manufactured with no holes and can easily be welded onto gates, dumpsters, and industrial applications such as bins or warehouse doors

Hinge Size		Gauge of Metal	Pin Diameter	Recommended Max Door Weight (lbs)
Inches	mm			
4 x 4	102 x 102	0.179	0.312	150
4-1/2 x 4-1/2	114 x 114	0.179	0.322	150
5 x 5	127 x 127	0.179	0.322	175
6 x 6	152 x 152	0.203	0.500	230

1850 6 x 6 LP (Loose Oval Pin)

Hinge Size		Door Thickness	Max Door Width
Inches	mm		
4 x 4	102 x 102	1-3/8" (35 mm) to 1-3/4" (45 mm)	36" (91 cm)
4-1/2 x 4-1/2	114 x 114	1-3/4" (45 mm) to 2" (51 mm)	36" (91 cm)
5 x 5	127 x 127	1-3/4" (45 mm) to 2-1/2" (64 mm)	42" (107 cm)
6 x 6	152 x 152	1-3/4" (45 mm) to 2-1/2" (64 mm)	48" (122 cm)

1850 6 x 6 LP (Loose Oval Pin)

### SPRING HINGES



#### 1303

**Double Acting**

- Steel (ANSI K81041)
- Adjustable

Product	Hinge Size		3 Hinges Max Door Weight	3 Hinges Max Door Width
	Inches	mm		
1303-3	3	76	35 lbs	2'-8"
1303-4	4	102	75 lbs	3'
1303-5	5	127	90 lbs	3'
1303-6	6	152	100 lbs	3'
Product	Min Door Thickness	Min Door Height	Wood Screw	
1303-3	3/4" - 1"	5'-0"	6 x (#6 x 3/4" FPH WS)	
1303-4	7/8" - 1-1/4"	6'-8"	8 x (#6 x 3/4" FPH WS)	
1303-5	1-1/8" - 1-1/2"	6'-8"	10 x (#8 x 1-1/4" FPH WS)	
1303-6	1-1/4" - 1-3/4"	7'-0"	10 x (#10 x 1-1/4" FPH WS)	







## HALF SURFACE

### THREE KNUCKLE HINGES



**AB703**  
**Concealed Anti-Friction Bearing - Standard Weight**  
 Steel with steel pin (ANSI A8412)

**AB803**  
**Concealed Anti-Friction Bearing - Standard Weight**

- Brass with stainless steel pin (ANSI A2412) or stainless steel with stainless steel pin (ANSI A5412)
- Thru-bolts and grommets for wood door applications
- Non-rising removable pin with flush pin and plug
- Reversible
- Beveled surface leaf
- For use on medium weight hollow metal or wood composite doors with hollow metal frames requiring medium frequency service



**AB753**  
**Concealed Anti-Friction Bearing - Heavy Weight**  
 Steel with steel pin (ANSI A8411)

**AB853**  
**Concealed Anti-Friction Bearing - Heavy Weight**

- Brass with stainless steel pin (ANSI A2411) or stainless steel with stainless steel pin (ANSI A5411)
- Thru-bolts and grommets for wood door applications
- Non-rising removable pin with flush pin and plug
- Reversible
- Beveled surface leaf
- For use on heavy weight hollow metal or wood composite doors with hollow metal frames requiring high frequency service

Hinge Size		Gauge of Metal	Hole Count	Machine Screw Size	
Inches	mm			Door Leaf	Jamb Leaf
4-1/2	114	0.134	7	2 x 1/4-20 OH	1/2 x 12-24 FH
5	127	0.145	8	2 x 1/4-20 OH	1/2 x 12-24 FH

Hinge Size		Gauge of Metal	Hole Count	Machine Screw Size	
Inches	mm			Door Leaf	Jamb Leaf
4-1/2	114	0.180	7	2 x 1/4-20 OH	1/2 x 12-24 FH
5	127	0.190	8	2 x 1/4-20 OH	1/2 x 12-24 FH
6+	152	0.203* 0.190*	10	2 x 1/4-20 OH	1/2 x 1/4-20 FH

Hinge Size		Door Leaf Width "A"		Jamb Leaf Width "B"		Jamb Leaf Offset "C"		Application "D"	
Inches	mm	Inches	mm	Inches	mm	Inches	mm	Inches	mm
4-1/2	114	2-9/16	65	2	51	1/2	12.5	1-1/2	38
5	127	2-7/8	73	2	51	1/2	12.5	1-1/2	38

Hinge Size		Door Leaf Width "A"		Jamb Leaf Width "B"		Jamb Leaf Offset "C"		Application "D"	
Inches	mm	Inches	mm	Inches	mm	Inches	mm	Inches	mm
4-1/2	114	2-9/16	65	2-1/16	52	9/16	14	1-1/2	38
5	127	2-7/8	73	2-1/16	52	9/16	14	1-1/2	38
6+	152	3-1/4	83	2-1/8 or 2-1/2	54 or 64	5/8	16	1-1/2 or 1-7/8	38 or 48

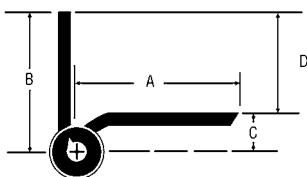

+ Door thickness must be specified.  
 \* 0.203 for brass and steel. 0.190 for stainless steel.



## HALF SURFACE

### FIVE KNUCKLE HINGES



#### 1173

##### Plain Bearing - Standard Weight

- Steel with steel pin (ANSI A8433)
- Thru-bolts and grommets for wood door applications
- Non-rising removable pin with button tip and plug
- Reversible
- Beveled surface leaf
- For use on regular weight hollow metal or wood composite doors with hollow metal frames requiring low frequency service



#### BB1163

##### Ball Bearing - Heavy Weight

Steel with steel pin (ANSI A8411)

#### BB2113

##### Ball Bearing - Heavy Weight

- Brass with stainless steel pin (ANSI A2411) or stainless steel with stainless steel pin (ANSI A5411)
- Four ball bearings
- Thru-bolts and grommets for wood door applications
- Non-rising removable pin with button tip and plug
- Reversible
- Beveled surface leaf
- For use on heavy weight hollow metal or wood composite doors with hollow metal frames requiring high frequency service

Hinge Size		Gauge of Metal	Hole Count	Machine Screw Size	
Inches	mm			Door Leaf	Jamb Leaf
3-1/2*	89	0.119	6	1-3/4 x 10-24 OH	1/2 x 10-24 FH
4*	102	0.129	7	2 x 1/4-20 OH	1/2 x 12-24 FH
4-1/2	114	0.134	7	2 x 1/4-20 OH	1/2 x 12-24 FH

Hinge Size		Door Leaf Width "A"		Jamb Leaf Width "B"		Jamb Leaf Offset "C"		Application "D"	
Inches	mm	Inches	mm	Inches	mm	Inches	mm	Inches	mm
3-1/2*	89	1-5/8	41	1-9/16	31	7/16	11.5	1-1/16	27
4*	102	2-5/16	59	1-13/16	46	1/2	13	1-5/16	33
4-1/2	114	2-9/16	65	2	51	1/2	12.5	1-1/2	38

\* For 1-3/8" door

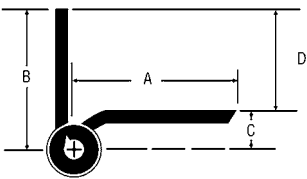

Hinge Size		Gauge of Metal	Hole Count	Machine Screw Size	
Inches	mm			Door Leaf	Jamb Leaf
4-1/2	114	0.180	7	2 x 1/4-20 OH	1/2 x 12-24 FH
5	127	0.190	8	2 x 1/4-20 OH	1/2 x 12-24 FH
6+	152	0.203* 0.190*	10	2 x 1/4-20 OH	1/2 x 1/4-20 FH

Hinge Size		Door Leaf Width "A"		Jamb Leaf Width "B"		Jamb Leaf Offset "C"		Application "D"	
Inches	mm	Inches	mm	Inches	mm	Inches	mm	Inches	mm
4-1/2	114	2-9/16	65	2-1/16	38	9/16	14	7/16	11
5	127	2-7/8	73	2-1/16	38	9/16	14	7/16	11
6+	152	3-1/4	83	2-1/8 or 2-1/2	54 or 64	5/8	16	1-1/2 or 1-7/8	38 or 48

+ Door thickness must be specified.

\* 0.203 for brass and steel. 0.190 for stainless steel.





## HALF SURFACE

### FIVE KNUCKLE HINGES



#### BB1173

##### Ball Bearing - Standard Weight

Steel with steel pin (ANSI A8412)

#### BB2112

##### Ball Bearing - Standard Weight

- Brass with stainless steel pin (ANSI A2412) or stainless steel with stainless steel pin (ANSI A5412)
- Two ball bearings
- Thru-bolts and grommets for wood door applications
- Non-rising removable pin with button tip and plug
- Reversible
- Beveled surface leaf
- For use on regular weight hollow metal or wood composite doors with hollow metal frames requiring medium frequency service
- For 1-3/8" door
- For 1-3/4" door. 4" is available. Consult Hager Tech Department.

Hinge Size		Gauge of Metal	Hole Count	Machine Screw Size	
Inches	mm			Door Leaf	Jamb Leaf
4*	102	0.129	7	2 x 1/4-20 OH	1/2 x 12-24 FH
4-1/2	114	0.134	7	2 x 1/4-20 OH	1/2 x 12-24 FH
5	127	0.145	8	2 x 1/4-20 OH	1/2 x 12-20 FH

Hinge Size		Door Leaf Width "A"		Jamb Leaf Width "B"		Door Leaf Offset "C"		Application "D"	
Inches	mm	Inches	mm	Inches	mm	Inches	mm	Inches	mm
4*	102	2-5/16	59	1-13/16	46	1/2	13	1-5/16	33
4-1/2	114	2-9/16	65	2	51	1/2	12.5	1-1/2	38
5	127	2-7/8	73	2	51	1/2	12.5	1-1/2	38

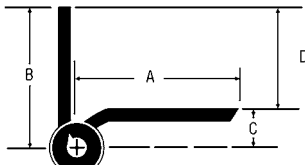

### SPRING HINGES



#### 1253

##### Single Acting

- Steel (ANSI K81081F)
- Thru-bolts and grommets for wood door applications
- For maximum versatility use all spring hinges or a combination of spring and ball bearing hinges (do not use plain bearing hinges)
- Full spring tension may not be required on all hinges
- Strong wind conditions, drafts, carpeting drag, twisted/misaligned frames, or weatherstripping on doors may require additional spring hinges
- For automatic closing of door



Hinge Size		Gauge of Metal	Hole Count	Machine Screw Size	
Inches	mm			Door Leaf	Jamb Leaf
4-1/2	114	0.134	7	2 x 1/4-20 with grommet nuts	1/2 x 12-24

Hinge Size		Door Leaf Width "A"		Jamb Leaf Width "B"		Door Leaf Offset "C"		Application "D"	
Inches	mm	Inches	mm	Inches	mm	Inches	mm	Inches	mm
4-1/2	114	2-9/16	65	2	52	1/2	14	1-1/2	38

Hinge Size		Recommended Max Door Weight		Spring Hinge	Ball Bearing Hinge	Spring Hinge Location
Inches	mm	lbs	kg			
4-1/2	114	70	32	1	2	Center
4-1/2	114	115	52	2	1	Top or Bottom
4-1/2	114	150	68	3	-	All



## ALUMINUM ENTRANCE - SLIP IN HINGES

### FIVE KNUCKLE

The following hinges are for use on aluminum doors with aluminum frames. They are applied by inserting the hinge leaves through a slot in the door or frame. These hinges:

- Have a non-rising removable pin with button tip and plug
- Are handed
- Use ball bearings when door closers are installed on doors



**1277**  
**Plain Bearing - Standard Weight**  
**Both Leaves Tapped**  
 Steel with steel pin  
 [ANSI A8143, 5/16" (8 mm) Swag]

**1278**  
**Plain Bearing - Standard Weight**  
**One Leaf Tapped**  
 Steel with steel pin  
 [ANSI A8153, 3/16" (5 mm) Swag]

**1577**  
**Plain Bearing - Standard Weight**  
**Both Leaves Tapped**  
 Brass with stainless steel pin  
 [ANSI A2143, 5/16" (8 mm) Swag] or  
 stainless steel with stainless steel pin  
 [ANSI A5143, 5/16" (8 mm) Swag]

**1578**  
**Plain Bearing - Standard Weight**  
**One Leaf Tapped**  
 Brass with stainless steel pin  
 [ANSI A2153, 3/16" (5 mm) Swag] or  
 stainless steel with stainless steel pin  
 [ANSI A5143, 3/16" (5 mm) Swag]



**BB1277**  
**Ball Bearing - Standard Weight**  
**Both Leaves Tapped**  
 Steel with steel pin  
 [ANSI A8142, 5/16" (8 mm) Swag]

**BB1278**  
**Ball Bearing - Standard Weight**  
**One Leaf Tapped**  
 Steel with steel pin  
 [ANSI A8152, 3/16" (5 mm) Swag]

**BB1577**  
**Ball Bearing - Standard Weight**  
**Both Leaves Tapped**  
 Brass with stainless steel pin  
 [ANSI A2142, 5/16" (8 mm) Swag] or  
 stainless steel with stainless steel pin  
 [ANSI A5142, 5/16" (8 mm) Swag]

**BB1578**  
**Ball Bearing - Standard Weight**  
**One Leaf Tapped**  
 Brass with stainless steel pin  
 [ANSI A2152, 3/16" (5 mm) Swag] or  
 stainless steel with stainless steel pin  
 [ANSI A5142, 3/16" (5 mm) Swag]

Hinge Size		Gauge of Metal	Hole Count	Screw Size	
Inches	mm			Machine	Wood
4-1/2 x 4	114 x 102	0.134	8	1/2 x 12-24	1-1/4 x 12
4-1/2 x 4-1/2	114 x 114	0.134	8	1/2 x 12-24	1-1/4 x 12

Hinge Size		Gauge of Metal	Hole Count	Screw Size	
Inches	mm			Machine	Wood
4-1/2 x 4	114 x 102	0.134	8	1/2 x 12-24	1-1/4 x 12
4-1/2 x 4-1/2	114 x 114	0.134	8	1/2 x 12-24	1-1/4 x 12

4-1/2 x 3-1/2 - see template T-209 on Hager website - [www.hagerco.com](http://www.hagerco.com).





## SWING CLEAR

### THREE KNUCKLE HINGES



#### AB7001 | AB7002 Full Mortise - Concealed Anti-Friction Bearing - Standard Weight

- Steel with steel pin (ANSI A8122)
- Non-rising removable pin with flush pin and plug
- Reversible
- When opened 90°, door projects 3/32" (2 mm) past stop of jamb
- For use in hospitals or other institutional type buildings
- AB7001 is for square edge doors and AB7002 is for beveled edge doors
- Assembled RH - Reversible to LH



Hinge Size		Gauge of Metal	Hole Count	Screw Size	
Inches	mm			Machine	Wood
4-1/2	114	0.139	8	1/2 x 12-24 FH	1-1/4 x 12 FH
5	127	0.139	8	1/2 x 12-24 FH	1-1/4 x 12 FH



#### AB7511 | AB7512 Half Mortise - Concealed Anti-Friction Bearing - Heavy Weight

- Steel with steel pin (ANSI A8221)
- Non-rising removable pin with flush pin and plug
- Reversible
- When opened 90°, door projects 11/64" (4 mm) past stop of jamb
- For use in hospitals or other institutional type buildings
- AB7511 is for square edge doors and AB7512 is for beveled edge doors
- Assembled RH - Reversible to LH



Hinge Size		Gauge of Metal	Hole Count	Screw Size	
Inches	mm			Machine	Wood
5	127	0.187	8	1/2 x 12-24 FH 1-1/4 x 12 FH	1/2 x 1/4-20 FH 1-1/2 x 14 FH



#### AB7501 | AB7502 Full Mortise - Concealed Anti-Friction Bearing - Heavy Weight

- Steel with steel pin (ANSI A8121)
- Non-rising removable pin with flush pin and plug
- Reversible
- When opened 90°, door projects 11/64" (4 mm) past stop of jamb
- For use in hospitals or other institutional type buildings
- AB7501 is for square edge doors and AB7502 is for beveled edge doors
- Assembled RH - Reversible to LH



Hinge Size		Gauge of Metal	Hole Count	Screw Size	
Inches	mm			Machine	Wood
4-1/2	114	0.187	8	1/2 x 12-24 FH	1-1/4 x 12 FH
5	127	0.187	8	1/2 x 12-24 FH	1-1/4 x 12 FH



#### AB7523 Full Surface - Concealed Anti-Friction Bearing - Heavy Weight

- Steel with steel pin (ANSI A8321)
- Non-rising removable pin with flush pin and plug
- Reversible
- Beveled surface leaves
- When opened 90°, door projects 11/64" (4 mm) past stop of jamb
- For use in hospitals or other institutional type buildings
- Assembled RH - Reversible to LH



Hinge Size		Gauge of Metal	Hole Count	Screw Size	
Inches	mm			Machine	Wood
5	127	0.187	9	2 x 1/4-20 FH	1/2 x 12-24 FH



#### AB7534 Half Surface - Concealed Anti-Friction Bearing - Heavy Weight

- Steel with steel pin (ANSI A8421)
- Non-rising removable pin with flush pin and plug
- Reversible
- Beveled surface leaf
- When opened 90°, door projects 11/64" (4 mm) past stop of jamb
- For use in hospitals or other institutional type buildings
- Assembled RH - Reversible to LH



Hinge Size		Gauge of Metal	Hole Count	Screw Size	
Inches	mm			Machine	Wood
5	127	0.187	9	2 x 1/4-20 FH	1/2 x 12-24 FH



# SWING CLEAR

## FIVE KNUCKLE HINGES



### 1260 | 1261 Full Mortise - Plain Bearing - Standard Weight

- Steel with steel pin (ANSI A8123)
- Non-rising removable pin with button tip and plug
- Reversible
- When opened 90°, door projects 9/64" (4 mm) past stop of jamb for 3-1/2" hinge and 3/16" (5 mm) past stop of jamb for 4" hinge
- For residential and commercial use
- 1260 is for square edge doors and 1261 is for beveled edge doors
- Assembled RH - reversible to LH



### BB1262 | BB1263 Full Mortise - Ball Bearing - Heavy Weight

- Steel with steel pin (ANSI A8121)
- Four ball bearings
- Non-rising removable pin with button tip and plug
- Reversible
- When opened 90°, door projects 11/64" (4 mm) past stop of jamb
- For use in hospitals or other institutional type buildings
- BB1262 is for square edge doors and BB1263 is for beveled edge doors
- Assembled RH - reversible to LH



Hinge Size		Gauge of Metal	Hole Count	Screw Size	
Inches	mm			Machine	Wood
3-1/2	89	0.119	6	1/2 x 10-24 FH	1 x 9 FH
4	102	0.129	8	1/2 x 12-24 FH	1-1/4 x 12 FH

Hinge Size		Gauge of Metal	Hole Count	Screw Size	
Inches	mm			Machine	Wood
4-1/2	114	0.180	8	1/2 x 12-24 FH	1-1/4 x 12 FH
5	127	0.190	8	1/2 x 12-24 FH	1-1/4 x 12 FH



### BB1260 | BB1261 Full Mortise - Ball Bearing - Standard Weight

- Steel with steel pin (ANSI A8122)
- Two ball bearings
- Non-rising removable pin with button tip and plug
- Reversible
- When opened 90°, door projects 3/32" (2 mm) past stop of jamb
- For use in hospitals or other institutional type buildings
- BB1260 is for square edge doors and BB1261 is for beveled edge doors
- Assembled RH - reversible to LH



### BB1360 | BB1361 Full Mortise - Ball Bearing - Standard Weight

- Stainless steel with stainless steel pin (ANSI A5122)
- Two ball bearings
- Non-rising removable pin with button tip and plug
- Reversible
- When opened 90°, door projects 3/32" (2 mm) past stop of jamb
- For use in hospitals or other institutional type buildings
- BB1360 is for square edge doors and BB1361 is for beveled edge doors
- Assembled RH - reversible to LH



Hinge Size		Gauge of Metal	Hole Count	Screw Size	
Inches	mm			Machine	Wood
4-1/2	114	0.134	8	1/2 x 12-24 FH	1-1/4 x 12 FH
5	127	0.145	8	1/2 x 12-24 FH	1-1/4 x 12 FH

Hinge Size		Gauge of Metal	Hole Count	Screw Size	
Inches	mm			Machine	Wood
4-1/2	114	0.134	8	1/2 x 12-24 FH	1-1/4 x 12 FH
5	127	0.145	8	1/2 x 12-24 FH	1-1/4 x 12 FH





## SWING CLEAR

### FIVE KNUCKLE HINGES



#### BB1362 | BB1363 Full Mortise - Ball Bearing - Heavy Weight

- Stainless steel with stainless steel pin (ANSI A5121)
- Four ball bearings
- Non-rising removable pin with button tip and plug
- Reversible
- When opened 90°, door projects 11/64" (4 mm) past stop of jamb
- For use in hospitals or other institutional type buildings
- BB1362 is for square edge doors and BB1363 is for beveled edge doors
- Assembled RH - reversible to LH



#### BB1266 Full Surface - Ball Bearing - Heavy Weight

- Steel with stainless steel pin (ANSI A8321)
- Four ball bearings
- Non-rising removable pin with button tip and plug
- Reversible
- Beveled surface leaves
- When opened 90°, door projects 11/64" (4 mm) past stop of jamb
- For use in hospitals or other institutional type buildings
- Assembled RH - reversible to LH



Hinge Size		Gauge of Metal	Hole Count	Machine Screw Size	
Inches	mm			Door Leaf	Jamb Leaf
4-1/2	114	0.180	8	1/2 x 12-24 FH	1-1/4 x 12 FH
5	127	0.190	8	1/2 x 12-24 FH	1-1/4 x 12 FH

Hinge Size		Gauge of Metal	Hole Count	Machine Screw Size	
Inches	mm			Door Leaf	Jamb Leaf
5	127	0.187	9	2 x 1/4-20 FH	1/2 x 1/4-20 FH



#### BB1264 | BB1265 Half Mortise - Ball Bearing - Heavy Weight

- Steel with steel pin (ANSI A8221)
- Four ball bearings
- Non-rising removable pin with button tip and plug
- Reversible
- When opened 90°, door projects 11/64" (4 mm) past stop of jamb
- For use in hospitals or other institutional type buildings
- BB1264 is for square edge doors and BB1265 is for beveled edge doors
- Assembled RH - reversible to LH



#### BB1270 Half Surface - Ball Bearing - Heavy Weight

- Steel with stainless steel pin (ANSI A8421)
- Four ball bearings
- Non-rising removable pin with button tip and plug
- Reversible
- Beveled surface leaf
- When opened 90°, door projects 11/64" (4 mm) past stop of jamb
- For use in hospitals or other institutional type buildings
- Assembled RH - reversible to LH



Hinge Size		Gauge of Metal	Hole Count	Screw Size	
Inches	mm			Machine	Wood
5	127	0.187	8	1/2 x 12-24 FH	1-1/4 x 12 FH
				Jamb Leaf Screw Size	
				Machine	Wood
				1/2 x 1/4-20 FH	1-1/4 x 12 FH

Hinge Size		Gauge of Metal	Hole Count	Machine Screw Size	
Inches	mm			Door Leaf	Jamb Leaf
5	127	0.187	9	2 x 1/4-20 FH	1/2 x 12-24 FH



**THREE KNUCKLE HINGES**



**AB7505**  
**Concealed Anti-Friction Bearing - Heavy Weight**  
 Steel with steel pin (ANSI A8551)

**AB8505**  
**Concealed Anti-Friction Bearing - Heavy Weight**

- Brass with stainless steel pin (ANSI A2511) or stainless steel with stainless steel pin (ANSI A5511)
- Non-removable pin standard with flush pin and plug
- Handed
- One anchor leaf (frame)
- Must be used with one pair of heavy weight, full mortise hinges (AB750 or AB850) - sold separately
- For use on heavy weight doors receiving high frequency use



**AB7507 | AB7509**  
**Concealed Anti-Friction Bearing - Heavy Weight**  
 Steel with steel pin (ANSI A8551)

**AB8507 | AB8509**  
**Concealed Anti-Friction Bearing - Heavy Weight**

- Brass with stainless steel pin (ANSI A2551) or stainless steel with stainless steel pin (ANSI A5551)
- Non-removable pin standard with flush pin and plug
- Handed
- Two anchor leaves
- Must be used with one pair of heavy weight, full mortise hinges (AB750 or AB850) - sold separately
- For use on heavy weight doors receiving high frequency use and when concealed door closer is used
- AB7507 is for square edge doors and AB7509 is for beveled edge doors
- AB8507 is for square edge doors and AB8509 is for beveled edge doors

Hinge Size		Gauge of Metal	Hole Count	Screw Size	
Inches	mm			Machine	Wood
5 x 4-1/2	127 x 114	0.190	12	1/2 x 12-24	1-1/4 x 12

Hinge Size		Gauge of Metal	Hole Count	Screw Size	
Inches	mm			Machine	Wood
5 x 4-1/2	127 x 114	0.190	15	1/2 x 12-24	1-1/4 x 12



**AB7506 | AB7508**  
**Concealed Anti-Friction Bearing - Heavy Weight**  
 Steel with steel pin (ANSI A8551)

**AB8506 | AB8508**  
**Concealed Anti-Friction Bearing - Heavy Weight**

- Brass with stainless steel pin (ANSI A2551) or stainless steel with stainless steel pin (ANSI A5551)
- Non-removable pin standard with flush pin and plug
- Handed
- Two anchor leaves
- Must be used with one pair of heavy weight, full mortise hinges (AB750 or AB850) - sold separately
- For use on heavy weight doors receiving high frequency use
- AB7506 is for square edge doors and AB7508 is for beveled edge doors
- AB8506 is for square edge doors and AB8508 is for beveled edge doors

Hinge Size		Gauge of Metal	Hole Count	Screw Size	
Inches	mm			Machine	Wood
5 x 4-1/2	127 x 114	0.190	18	1/2 x 12-24	1-1/4 x 12







## ANCHORS

### FIVE KNUCKLE HINGES



**BB1160**  
**Ball Bearing - Heavy Weight**  
 Steel with steel pin (ANSI A8551)

- BB1190**  
**Ball Bearing - Heavy Weight**
- Brass with stainless steel pin (ANSI A2551) or stainless steel with stainless steel pin (ANSI A5551)
  - Four ball bearings
  - Non-removable pin standard with button tip and plug
  - Handed
  - One anchor leaf (frame)
  - Must be used with one pair of heavy weight, full mortise hinges (BB1168 or BB1199) - sold separately
  - For use on heavy weight doors receiving high frequency use



**BB1165 | BB1167**  
**Ball Bearing - Heavy Weight**  
 Steel with steel pin (ANSI A8551)

- BB1195 | BB1197**  
**Ball Bearing - Heavy Weight**
- Brass with stainless steel pin (ANSI A2551) or stainless steel with stainless steel pin (ANSI A5551)
  - Four ball bearings
  - Non-removable pin standard with button tip and plug
  - Handed
  - Two anchor leaves
  - Must be used with one pair of heavy weight, full mortise hinges (BB1168 or BB1199) - sold separately
  - For use on heavy weight doors receiving high frequency use and when concealed door closer is used
  - BB1165 is for square edge doors and BB1167 is for beveled edge doors
  - BB1195 is for square edge doors and BB1197 is for beveled edge doors

Hinge Size		Gauge of Metal	Hole Count	Screw Size	
Inches	mm			Machine	Wood
5 x 4-1/2	127 x 114	0.190	12	1/2 x 12-24	1-1/4 x 12



**BB1162 | BB1166**  
**Ball Bearing - Heavy Weight**  
 Steel with steel pin (ANSI A8551)

- BB1192 | BB1196**  
**Ball Bearing - Heavy Weight**
- Brass with stainless steel pin (ANSI A2551) or stainless steel with stainless steel pin (ANSI A5551)
  - Four ball bearings
  - Non-removable pin standard with button tip and plug
  - Handed
  - Two anchor leaves
  - Must be used with one pair of heavy weight, full mortise hinges (BB1168 or BB1199) - sold separately
  - For use on heavy weight doors receiving high frequency use
  - BB1162 is for square edge doors and BB1166 is for beveled edge doors
  - BB1192 is for square edge doors and BB1196 is for beveled edge doors

Hinge Size		Gauge of Metal	Hole Count	Screw Size	
Inches	mm			Machine	Wood
5 x 4-1/2	127 x 114	0.190	15	1/2 x 12-24	1-1/4 x 12

Hinge Size		Gauge of Metal	Hole Count	Screw Size	
Inches	mm			Machine	Wood
5 x 4-1/2	127 x 114	0.190	18	1/2 x 12-24	1-1/4 x 12



## PIVOTS

### REINFORCING



#### 251

##### Full Surface

- For 3-1/2" (89 mm) wide hinge
- Handed

#### 252

##### Full Surface

- For 4" (102 mm) wide hinge
- Non-handed

#### 253

##### Full Surface

- For 4-1/2" (114 mm) wide hinge
- Non-handed

#### 254

##### Full Surface

- For 5" (127 mm) wide hinge
- Non-handed

Product	Butt Hinge Width		Projection*		Door Thickness	
	Inches	mm	Inches	mm	Inches	mm
251	3-1/2	89	5/8	16	1-3/8	35
252	4	102	1/2	12.5	1-3/4	45
253	4-1/2	114	3/4	19	1-3/4	45
254	5	127	1	25	1-3/4	45

\*Projection from centerline of pivot to face of door.

Gauge of Metal	Screw Size	
	Machine	Wood
0.187	3/4 x 1/4-20	1-1/4 x 14

### BALL AND THRUST BEARING - HEAVY WEIGHT



#### 495

##### Top

Forged bronze (ANSI C07162)



#### 496

##### Intermediate

- Forged bronze (ANSI C07321)
- Handed



#### 497

##### Bottom

- Forged bronze (ANSI C07131)
- 3/4" (19 mm) offset
- Two knuckle
- For doors up to and including 3'0" x 8'0" (912 mm x 2438 mm) weighing maximum of 350 pounds, apply all three pivots 495, 496, 497
- For doors over 3'6" (1067 mm) up to 4'0" (1219 mm) in width, add one additional intermediate pivot, 496
- For each additional 12" (305 mm) in door height over 8'0" (2438 mm) add one intermediate pivot, 496
- Handed

Product	Hole Count	Screw Size	
		Machine	Wood
495	8	5/8 x 1/4-20	1-1/2 x 14
496	10	5/8 x 1/4-20	1-1/2 x 14
497	8	5/8 x 1/4-20	1-1/2 x 14





## PIVOTS

### SINGLE ACTING - STANDARD WEIGHT

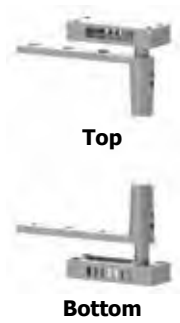

#### 500

##### Rack and Pinion

- ANSI A2793
- Pivot opens door to 105° maximum
- Non-handed
- Concealed
- Adjustable alignment

Designed for:

- 1-3/4" (45 mm) thick door
- Maximum weight not over 80 pounds
- Not to exceed 3' (914 mm) wide and 7' (2134 mm) high
- Cased opening frame required
- Consult Hager Tech Support for doors other than 1-3/4" (44 mm)

### SINGLE ACTING - EXTRA HEAVY WEIGHT



#### 551

##### Extra Heavy Duty Rack and Pinion

- ANSI A2792
- Pivot opens door to 105° maximum
- Non-handed
- Concealed
- Adjustable alignment

Designed for:

- 1-3/4" (45 mm) thick door
- Maximum weight not over 180 pounds
- Not to exceed 4" (102 mm) wide and 8" (203 mm) high
- Cased opening frame required
- Consult Hager Tech Support for doors other than 1-3/4" (44 mm)

Screw Size	
Machine	Wood
Upon request	1-1/4 x 12 FH*

\*Plastic cinch anchors

Screw Size	
Machine	Wood
Upon request	1-1/4 x 12 FH*

\*Plastic cinch anchors

### SINGLE ACTING - HEAVY WEIGHT



#### 550

##### Heavy Duty Rack and Pinion

- ANSI A2792
- Pivot opens door to 105° maximum
- Non-handed
- Concealed
- Adjustable alignment

Designed for:

- 1-3/4" (45 mm) thick door
- Maximum weight not over 150 pounds
- Not to exceed 3' (914 mm) wide and 7' (2134 mm) high
- Cased opening frame required
- Consult Hager Tech Support for doors other than 1-3/4" (44 mm)

### HEAVY WEIGHT



#### 615

##### For Frameless Openings

- ANSI A8782
- For use on doors up to 150 lbs and 1-3/8" - 1-3/4" (35 mm - 44 mm) thick
- Pivot opens door to 180° maximum
- Screw slots for horizontal or vertical adjustment

Wood Screw Size
12 x 1-1/4

Screw Size	
Machine	Wood
Upon request	1-1/4 x 12 FH*

\*Plastic cinch anchors



# PIVOTS

## CAMTROL DOUBLE ACTING - HOSPITAL SET - RESCUE HARDWARE

The following pivots are for use on:

- Wood or metal doors up to 135 lbs
- Doors not over 3'6" x 7' (1067 mm x 2134 mm)
- Wood or metal frames
- Allows for square edge door on lock side, bull nose not required

### Mortise Application in Wood Floors



#### 510 Head and Floor Pivots

- ANSI A5702
- For use with square edge doors on hinge side

#### 600 Head and Floor Pivots with Door Release (Set)

ANSI A5702

### Surface Application in Masonry Floors



#### 512 Head and Floor Pivots

- ANSI A5702
- For use with square edge doors on hinge side

#### 612 Head and Floor Pivots with Door Release (Set)

ANSI A5702

### Door Release



#### 610 Door Release

ANSI A1882

### Mortise Application in Masonry Floors



#### 511 Head and Floor Pivots

- ANSI A5702
- For use with square edge doors on hinge side

#### 611 Head and Floor Pivots with Door Release (Set)

ANSI A5702

Item No	Anchor Housing	
	Inches	mm
510 & 600	3-7/8 x 1-7/8 x 7/8	98 x 48 x 22
511 & 611	3-7/8 x 1-1/4 x 7/8	98 x 32 x 22
512 & 612	3-7/8 x 1-1/4 x 7/8	98 x 32 x 22

Door Mount Brackets Screw Size		Head Cam Box Screw Size		Floor Cam Box Screw Size	
Machine	Wood	Machine	Wood	Machine	Wood
1/2 x 12-24 FH	1-1/4 x 12 FH	1-1/4 x 12-24 FH	1-1/2 x 12-24 FH	-	1-1/2 x 12 FH

610					
Mortise Depth		Face Plate		Screw Size	
Inches	mm	Inches	mm	Machine	Wood
1-13/16	46	1-1/2 x 4-1/2 x 3/16	38 x 114 x 5	1/2 x 12-24 FH	1-1/4 x 12 FH

\*Plastic cinch anchors





## PIVOTS

### DOUBLE LIPPED STRIKE

#### 451

##### Center Hung Doors

- Brass
- ANSI A1882



Center Hung

#### 452

##### Center Hung Doors

- Brass
- ANSI A1882



1/8" (3.2 mm)  
Inset Hung

#### 453

##### 1/8" (3.2 mm) Inset Hung Doors

- Brass
- ANSI A1882

#### 454

##### 1/8" (3.2 mm) Inset Hung Doors

- Brass
- ANSI A1882
- To be used with Hager 600, 611, and 612 pivots and door release - this allows doors to be opened in both directions without damage to frame
- Standard latchbolt cutout is 1-1/4" x 11/16" (32 mm x 17 mm)
- Standard strike plates are optimized for cylindrical locks/latches mounted on 1-3/4" thick doors
- Mortise lock applications require special latch cutout location (consult specific manufactures for variations of cutout dimensions)
- For use with Camtrol double acting pivot

### COMBINATION RESCUE DOOR STOP AND TWO WAY STRIKE PLATE (EMERGENCY STRIKE)

#### 455

##### Center Hung Doors

- Brass
- ANSI A1882



Center Hung

#### 456

##### Center Hung Doors

- Brass
- ANSI A1882



1/8" (3.2 mm)  
Inset Hung

#### 457

##### 1/8" (3.2 mm) Inset Hung Doors

- Brass
- ANSI A1882

#### 458

##### 1/8" (3.2 mm) Inset Hung Doors

- Brass
- ANSI A1882
- Handed
- To be used with Hager 510, 511, and 512 pivots
- Door release allows doors to be opened in both directions without damage to frame
- Standard latchbolt cutout is 1-1/4" x 11/16" (32 mm x 17 mm)
- Standard strike plates are optimized for cylindrical locks/latches mounted on 1-3/4" thick doors
- Mortise lock applications require special latch cutout location (consult specific manufactures for variations of cutout dimensions)

Product	Face Plate		Gauge of Metal	Hole Count	Screw Size
	Inches	mm			
451	5-3/4 x 2-3/4	146 x 70	0.093	6	1/2 x 8-32 FH
452	6-3/4 x 2-3/4	171 x 70	0.093	6	1/2 x 8-32 FH
453	5-3/4 x 2-3/4	146 x 70	0.093	6	1/2 x 8-32 FH
454	6-3/4 x 2-3/4	171 x 70	0.093	6	1/2 x 8-32 FH

Product	Face Plate		Gauge of Metal	Hole Count	Screw Size
	Inches	mm			
455	5-3/4 x 2-3/4	146 x 70	0.093	6	1/2 x 8-32 FH
456	6-3/4 x 2-3/4	171 x 70	0.093	6	1/2 x 8-32 FH
457	5-3/4 x 2-3/4	146 x 70	0.093	6	1/2 x 8-32 FH
458	6-3/4 x 2-3/4	171 x 70	0.093	6	1/2 x 8-32 FH

Catalog Number	Frame Width	
452 & 454	4-3/4"	
	5-1/4"	
	5-7/8"	
	6-1/8"	
	6-1/4"	
	6-1/2"	
	Special Sizes Available	7-1/8"
		7-1/2"
		7-3/4"
		8
	8-1/4"	
	8-3/4"	

Catalog Number	Frame Width	
456 & 458	4-3/4"	
	5-1/4"	
	5-7/8"	
	6-1/8"	
	6-1/4"	
	6-1/2"	
	Special Sizes Available	7-1/8"
		7-1/2"
		7-3/4"
		8
	8-1/4"	
	8-3/4"	





## DETENTION HARDWARE

### THREE KNUCKLE HINGES



#### **IHTHB953** **Full Mortise - Concealed Bearings - Heavy Weight**

- Stainless steel with stainless steel pin (ANSI A5111)
- Two concealed maintenance free bearings
- Investment cast
- Security torx screws
- Hospital tip and reverse security stud are standard
- Additional options include electric monitor (EMN), electric through wire (ETW), and electric through wire and monitor (ETM)
- For use on heavy weight doors ranging from 250-600 lbs

Hinge Size		Pin Diameter		Gauge of Metal	Hole Count	Machine Screw Size
Inches	mm	Inches	mm			
4-1/2 x 4-1/2	114 x 114	0.370	9	0.187	8	1/2 x 1/4-20 Torx



#### **IHTAB750** **Institutional Prison Hinge** Steel with stainless steel pin (ANSI A8111)

- Stainless steel with stainless steel pin (ANSI A5111)
- Concealed maintenance free bearings
- Welded hospital tips and plug
- Welded knuckles
- Additional options include security torx screws, electric monitor (EMN), electric through wire (ETW), electric through wire and monitor (ETM), reverse safety stud (RSS), and safety stud (SS)
- For use on heavy weight doors ranging from 200-300 lbs

**Made in USA**

Hinge Size		Pin Diameter		Gauge of Metal	Hole Count	Machine Screw Size
Inches	mm	Inches	mm			
4-1/2 x 4-1/2	114 x 114	0.322	8	0.180	8	1/2 x 12-24 FPHM
5 x 4-1/2	127 x 114	0.322	8	0.190	8	1/2 x 12-24 FPHM
5 x 5	127 x 127	0.322	8	0.190	8	1/2 x 12-24 FPHM



**Made in USA**

#### **990** **Full Surface Heavy Weight Prison Utility Hinge**

- Steel with steel pin (ANSI A8383)
- Plain bearing
- Welded pin
- Prime painted
- Torx button head bolt
- Two hinges support the weight of 150 lbs
- For use on small doors, access doors, and observation shutters

Hinge Size		Pin Diameter		Gauge of Metal	Hole Count	Machine Screw Size
Inches	mm	Inches	mm			
3 x 4	78 x 102	0.437	11	0.203	4	1 x #16-3/8 Torx



**Made in USA**

#### **992** **Full Surface Heavy Weight Prison Pass Through Hinge with Stop**

- Steel with steel pin (ANSI A8383)
- Plain bearing
- Welded pin
- Prime painted
- Torx button head bolt
- Two hinges support the weight of 150 lbs
- For use on pass through in door

Hinge Size		Pin Diameter		Gauge of Metal	Hole Count	Machine Screw Size
Inches	mm	Inches	mm			
3 x 4	78 x 102	0.437	11	0.203	4	1 x #16-3/8 Torx





## ACCESSORIES



### 100

#### Set Screw Set

- 1/8" x 10-32 set screws (quantity 300)
- 3/16" x 10-32 set screws (quantity 300)
- 3/32" hex key
- Hand tap "T" wrench
- 10-32 tap
- #21 drill bit
- This set converts removable pin hinges to non-removable pin (set screw in barrel) hinges as required



### 263

#### Sleeve Bolt

- Aluminum
- 9/16" (14 mm) head sex nut with 1/4" - 20 internal thread
- Knurled shoulder prevents bolt from turning
- Drill a 3/8" (9.5 mm) hole and insert the sex bolt
- Available in US2C finish only (compatible with US26D, US28, or US32D)
- For use in securing push bars, exposed door closers and other fixtures to doors 1-3/4" (45 mm) thick or greater



### 265

#### Molly Jack Nut (8S JN)

- Aluminum
- For use with the Hager reinforcing pivot hinges (250 Series)
- Easily installed by drilling a 7/16" (11.1 mm) pilot hole and following the instructions provided with each product
- For use in properly anchoring various products to hollow metal frames 3/16" - 3/8" (4.8 mm - 9.5 mm) thick



### 305

#### Hinge Reinforcement Plate

- Steel
- For metal frames
- Four (4) holes

Hinge Size		Width		Total Length	
Inches	mm	Inches	mm	Inches	mm
4-1/2	114	1.5	38	10	254
Offset		Gauge of Metal		Tapped for Screw	
0.074		0.154		12-24	



### 417

#### Back Plate

- Steel
- For wood doors
- For full or half surface hinges

Length		Width		Gauge of Metal
Inches	mm	Inches	mm	
4-5/8	117	1-13/16	46	0.074
5	127	2-1/8	54	0.097
Number of Holes		Machine Screw Size		
3		1/4 x 20		
4		1/4 x 20		



**ACCESSORIES**

**DECORATOR TIP KITS**



**1712**  
**Ball Standard Weight**



**1713**  
**Ball Heavy Weight**



**1716**  
**Acorn Standard Weight**



**1717**  
**Acorn Heavy Weight**



**1722**  
**Steeple Standard Weight**



**1723**  
**Steeple Heavy Weight**



**1728**  
**Urn Standard Weight**



**1729**  
**Urn Heavy Weight**

- Standard weight hinge size - 3-1/2" (89 mm), 4" (102 mm), 4-1/2" (114 mm), 5" (127 mm), 6" (152 mm)
- Heavy weight hinge size - 4-1/2" (114 mm), 5" (127 mm), 6" (152 mm), 8" (203 mm)
- Solid brass with stainless steel pin
- Conversion tips and pins for architectural grade hinges







**One Family. One Brand. One Vision.™**

[www.hagerco.com](http://www.hagerco.com)



**One Family. One Brand. One Vision.™**

[www.hagerco.com](http://www.hagerco.com)

# Residential Hinges



Serving the needs of the homeowner, contractor, pre-hung door supplier, and hardware supplier, Hager residential hinges offer several finishes and styles to enhance the design on any home.

Hager residential hinges are available in square and two sizes of radius corners to match home designs ranging from traditional to contemporary. Coordinating finishes is one of many all-important detail aspects of the design process and we offer finishes ranging from stainless steel, chrome, nickel, antique brass, flat black and bright brass, which is making a comeback in the interior design industry.

Several of our most popular hinges are offered in bulk packs for large projects and unassembled to be used in large door assembly processes.

## Table of Contents

General Information .....	2
Full Mortise - Five Knuckle .....	3-6
Full Mortise - Six Knuckle .....	6
Full Mortise - Spring .....	7
Accessories .....	8
Conestoga Barn Door Hardware Series .....	9-13



## GENERAL INFORMATION

Hager residential hinges are provided without lubrication. We recommend lubricating the hinges after installation. Remove the pin, apply white lithium grease to the pin, then re-insert. All residential hinges conform to the "Light Weight" requirements of ANSI A156.1.

### Finishes (not all hinges are available in all finishes)

US & Hager	Description	Steel	Brass	Stainless Steel
1D	Flat Black	631	N/A	N/A
2D	Brass Tone Dichromate	604	N/A	N/A
2CD	Brushed Zinc Plate	N/A	N/A	N/A
H2H x BP	Mechanical Galvanized	N/A	N/A	N/A
3	Bright Brass	632	605	N/A
3LB	Light Brass	N/A	N/A	N/A
4	Satin Brass	633	606	N/A
10A/US11	Antique Bronze, Lacquered	641/643	614	N/A
10R	Matte Lacquered Antique Bronze	N/A	N/A	N/A
15	Satin Nickel	646	619	N/A
26	Bright Chromium Plated	651	625	N/A
26D	Satin Chromium Plated	652	626	N/A
32	Stainless Steel Metal, Bright	N/A	N/A	629
32D	Stainless Steel Metal, Satin	N/A	N/A	630
32D x CLR	Stainless Steel Metal, Satin, clear	N/A	N/A	630
P	Prime Coat - Beige	600	600	N/A
ABA/US5	Antique Brass	638	609	N/A
AN/US15A	Antique Nickel	647	620	N/A

### Packing

Box pack - 2 hinges per box  
Bulk pack - 100 hinges per box

### Hager Residential Hole Patterns



**3-1/2" x 3-1/2"**  
Refer to template  
#T398



**4" x 4"**  
Refer to template  
#T399





## FULL MORTISE - FIVE KNUCKLE



### 1541

#### Plain Bearing

- Brass with brass pin (ANSI A2134) or stainless steel with stainless steel pin (ANSI A5134)
- Reversible
- Square corners
- Removable pin



### RC1542

#### Plain Bearing

- Brass with brass pin (ANSI A2134) or stainless steel with stainless steel pin (ANSI A5134)
- Reversible
- Round corners - 5/8" (16 mm) radius
- Removable pin



### BB1541

#### Ball Bearing

- Stainless steel with stainless steel pin (ANSI A5114)
- Reversible
- Square corners
- Removable pin



### RCBB1542

#### Ball Bearing

- Stainless steel with stainless steel pin (ANSI A5114)
- Reversible
- Round corners - 5/8" (16 mm) radius
- Removable pin



### RC1541

#### Plain Bearing

- Brass with brass pin (ANSI A2134) or stainless steel with stainless steel pin (ANSI A5134)
- Reversible
- Round corners - 1/4" (6 mm) radius
- Removable pin

Hinge Size		Gauge of Metal	Hole Count	Pin Diameter	Screw Size (Wood)
Inches	mm				
3-1/2 x 3-1/2	89 x 89	0.085	6	0.234	3/4 x 9 FH
4 x 4	102 x 102	0.085	8	0.234	3/4 x 9 FH



### RCBB1541

#### Ball Bearing

- Stainless steel with stainless steel pin (ANSI A5114)
- Reversible
- Round corners - 1/4" (6 mm) radius
- Removable pin



### 1543

#### Plain Bearing

- Brass with brass pin (ANSI A2134) or stainless steel with stainless steel pin (ANSI A5134)
- Assembled right hand
- Square by 5/8" (16 mm) radius
- Removable pin

Hinge Size		Gauge of Metal	Hole Count	Pin Diameter	Screw Size (Wood)
Inches	mm				
3-1/2 x 3-1/2	89 x 89	0.085	6	0.234	3/4 x 9 FH
4 x 4	102 x 102	0.085	8	0.234	3/4 x 9 FH



### BB1543

#### Ball Bearing

- Brass with brass pin (ANSI A2114) or stainless steel with stainless steel pin (ANSI A5114)
- Assembled right hand
- Square by 5/8" (16 mm) radius
- Removable pin

Hinge Size		Gauge of Metal	Hole Count	Pin Diameter	Screw Size (Wood)
Inches	mm				
4 x 4	102 x 102	0.085	8	0.234	3/4 x 9 FH



## FULL MORTISE - FIVE KNUCKLE



### 1741

#### Plain Bearing

- Steel with steel pin (ANSI A8134)
- Reversible
- Square corners
- Removable pin



### BB1741

#### Ball Bearing

- Steel with steel pin (ANSI A8114)
- Reversible
- Square corners
- Removable pin



### RC1741 | 7741

#### Plain Bearing

- Steel with steel pin (ANSI A8134)
- Reversible
- 7741 is RC1741 bulk unassembled
- RC1741 - specify box or bulk pack
- Round corners - 1/4" (6 mm) radius
- Removable pin



### RCBB1741

#### Ball Bearing

- Steel with steel pin (ANSI A8114)
- Reversible
- Round corners - 1/4" (6 mm) radius
- Removable pin



### RC1748

#### Plain Bearing

- Steel with steel pin (ANSI A8134)
- Reversible
- Round corners - 1/4" (6 mm) radius
- Removable pin
- Template hole pattern
- AMS and 1/2 wood screws

Hinge Size		Gauge of Metal	Hole Count	Pin Diameter	Screw Size
Inches	mm				
3-1/2 x 3-1/2	89 x 89	0.085	6	0.234	1/2 x 10-24 (machine) 1 x 9 FH (wood)



### RC1749

#### Plain Bearing

- Steel with steel pin (ANSI A8134)
- Reversible
- Round corners - 1/4" (6 mm) radius
- Removable pin
- Template hole pattern
- AMS and 1/2 wood screws

Hinge Size		Gauge of Metal	Hole Count	Pin Diameter	Screw Size
Inches	mm				
4 x 4	102 x 102	0.085	8	0.234	1/2 x 12-24 (machine) 1-1/4 x 12 (wood)

Hinge Size		Gauge of Metal	Hole Count	Pin Diameter	Screw Size (Wood)
Inches	mm				
3 x 3*	76 x 76*	0.085*	6*	0.234*	3/4 x 9 FH*
3-1/2 x 3-1/2	89 x 89	0.085	6	0.234	3/4 x 9 FH
4 x 4	102 x 102	0.085	8	0.234	3/4 x 9 FH

\*3 x 3 not available for BB1741 or RCBB1741.





## FULL MORTISE - FIVE KNUCKLE



### 1816

#### Plain Bearing

- Steel with steel pin (ANSI A8134)
- Assembled right hand
- Square by 5/8" (16 mm) radius
- Removable pin
- Bulk assembled



### BB1816

#### Ball Bearing

- Steel with steel pin (ANSI A8114)
- Assembled right hand
- Square by 5/8" (16 mm) radius
- Removable pin



### 1817

#### Plain Bearing

- Steel with steel pin (ANSI A8134)
- Assembled left hand
- Square by 5/8" (16 mm) radius
- Removable pin
- Bulk assembled



### BB1817

#### Ball Bearing

- Steel with steel pin (ANSI A8114)
- Assembled left hand
- Square by 5/8" (16 mm) radius
- Removable pin

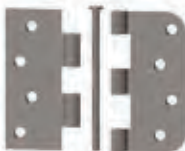

### 1848

#### Plain Bearing

- Steel with steel pin (ANSI A8134)
- Reversible
- Square by 5/8" (16 mm) radius
- Removable pin
- Unassembled - 2 per box
- AWS



### 8744

#### Plain Bearing

- Steel with steel pin (ANSI A8134)
- Square by 5/8" (16 mm) radius
- Bulk unassembled



### 1818

#### Plain Bearing

- Steel with steel pin (ANSI A8134)
- Assembled right hand
- Square by 5/8" (16 mm) radius
- Security stud
- Removable pin
- Bulk assembled



### 1819

#### Plain Bearing

- Steel with steel pin (ANSI A8134)
- Assembled left hand
- Square by 5/8" (16 mm) radius
- Security stud
- Removable pin
- Bulk assembled



### 8746

#### Plain Bearing

- Steel with steel pin (ANSI A8134)
- Square by 5/8" (16 mm) radius
- Safety stud
- Bulk unassembled

Hinge Size		Gauge of Metal	Hole Count	Pin Diameter	Screw Size (Wood)
Inches	mm				
4 x 4	102 x 102	0.085	8	0.234	3/4 x 9 FH

Hinge Size		Gauge of Metal	Hole Count	Pin Diameter	Screw Size (Wood)
Inches	mm				
4 x 4	102 x 102	0.085	8	0.234	3/4 x 9 FH



## FULL MORTISE - FIVE KNUCKLE



### RC1842 | RC1841 | 8741 Plain Bearing

- Steel with steel pin (ANSI A8134)
- Reversible
- Round corners - 5/8" (16 mm) radius
- RC1841 is RC1842 bulk assembled
- 8741 is RC1842 bulk unassembled
- RC1842 - Box pack (2 per box)
- Removable pin



### RCBB1842 Ball Bearing

- Steel with steel pin (ANSI A8114)
- Reversible
- Round corners - 5/8" (16 mm) radius
- Removable pin

Hinge Size		Gauge of Metal	Hole Count	Pin Diameter	Screw Size (Wood)
Inches	mm				
3-1/2 x 3-1/2	89 x 89	0.085	6	0.234	3/4 x 9 FH
4 x 4	102 x 102	0.085	8	0.234	3/4 x 9 FH



### RC1843 Plain Bearing

- Steel with steel pin (ANSI A8134)
- Reversible
- Round corners - 5/8" (16 mm) radius
- Removable pin
- Security stud

Hinge Size		Gauge of Metal	Hole Count	Pin Diameter	Screw Size (Wood)
Inches	mm				
4 x 4	102 x 102	0.085	8	0.234	3/4 x 9 FH



### RC1846 Plain Bearing

- Steel with steel pin (ANSI A8134)
- Reversible
- Round corners - 5/8" (16 mm) radius
- Riveted security pin
- Also available bulk assembled
- Not recommended for exterior use

Hinge Size		Gauge of Metal	Hole Count	Pin Diameter	Screw Size (Wood)
Inches	mm				
4 x 4	102 x 102	0.085	8	0.234	3/4 x 9 FH



### RC1847 Plain Bearing

- Steel with steel pin (ANSI A8134)
- Reversible
- Square by 5/8" (16 mm) radius
- Riveted security pin
- Also available bulk assembled

Hinge Size		Gauge of Metal	Hole Count	Pin Diameter	Screw Size (Wood)
Inches	mm				
4 x 4	102 x 102	0.085	8	0.234	3/4 x 9 FH

## SIX KNUCKLE



### RC1641 | 8641 Plain Bearing

- Steel with steel pin (ANSI A8134)
- Reversible
- Round corners - 5/8" (16 mm) radius
- Removable pin
- RC1641 is assembled, 8641 is bulk unassembled

Hinge Size		Gauge of Metal	Hole Count	Pin Diameter	Screw Size (Wood)
Inches	mm				
3-1/2 x 3-1/2	89 x 89	0.085	6	0.234	3/4 x 9 FH
4 x 4	102 x 102	0.085	8	0.234	3/4 x 9 FH







## FULL MORTISE - SPRING

Spring hinges are for automatic closing of doors. They are light weight for residential use. 1734 and 1744 are also for metal frames.

### Hinge Recommendation

Recommended Max Door Weight (lbs)	Spring Hinge	Butt Hinge	Spring Hinge Location
45	1	2	Center
70	2	1	Top/Btm or Ctr/Btm
90	3	-	All
45	1	2	Center
70	2	1	Top/Btm or Ctr/Btm
90	3	-	All



#### RC1734

- Stainless steel (ANSI K51071F)
- Round corners - 1/4" (6 mm) radius
- Template hole pattern

#### RC1744

- Steel (ANSI K81071F)
- Round corners - 1/4" (6 mm) radius
- Template hole pattern



Hinge Size		Gauge of Metal	Hole Count	Screw Size (Wood)
Inches	mm			
4 x 4	102 x 102	0.106	8	1-1/4" x 12 FPHW 12-12 x 1/2 FPHM

### Additional Notes for Spring Hinges

For maximum versatility use all spring hinges or a combination of spring hinges and residential ball bearing hinges. Do not use plain bearing hinges.

- Full spring tension may not be required on all hinges.
- Strong wind conditions, drafts, carpeting drag, twisted/ misaligned frames, or weatherstripping on doors may require additional spring hinges.
- Not intended for exterior outswing doors.
- For fire-rated openings use all 3 spring hinges.
- For doors over 7 feet, please call Hager Companies.



#### 1750

- Steel (ANSI K81071F)
- Square corners

#### RC1751

- Steel (ANSI K81071F)
- Round corners - 1/4" (6 mm) radius

#### RC1752

- Steel (ANSI K81071F)
- Round corners - 5/8" (16 mm) radius

#### 1760

- Stainless steel (ANSI K51071F)
- Square corners

#### RC1761

- Stainless steel (ANSI K51071F)
- Round corners - 1/4" (6 mm) radius

#### RC1762

- Stainless steel (ANSI K51071F)
- Round corners - 5/8" (16 mm) radius

Hinge Size		Gauge of Metal	Hole Count	Screw Size (Wood)
Inches	mm			
3-1/2 x 3-1/2	89 x 89	0.106	6	3/4 x 9 FH
4 x 4	102 x 102	0.106	8	1 x 9 FH



#### 1754

- Steel (ANSI K81071F)
- Square by 5/8" (16 mm) radius

#### 1764

- Stainless steel (ANSI K51071F)
- Square by 5/8" (16 mm) radius



Hinge Size		Gauge of Metal	Hole Count	Screw Size (Wood)
Inches	mm			
4 x 4	102 x 102	0.106	8	1 x 9 FH



## ACCESSORIES



### 1700

#### Pins for Residential Hinges

- Sizes:
- 3-1/2" (89 mm)
  - 4" (102 mm)
- Finishes:
- 3-1/2" - 2D, US15, US26D
  - 4" - 2D, US4, US15, US26D
- Notes:
- Sold in full box quantity of 100



### 1710

#### Residential Ball Tip Kit

- Materials: Brass tips and stainless steel pin
- Finishes: US3, US4, US5/ABA, US10A, US10R, US15, US15A/AN, US26, US26D
- Notes:
- Includes 2 ball tips and 1 pin
  - For use with 3-1/2" (89 mm) or 4" (102 mm) hinges



### 1720

#### Residential Steeple Tip Kit

- Materials: Brass tips and stainless steel pin
- Finishes: US3, US4, US5/ABA, US10A, US10R, US15, US15A/AN, US26, US26D
- Notes:
- Includes 2 steeple tips and 1 pin
  - For use with 3-1/2" (89 mm) or 4" (102 mm) hinges





## 9400 SERIES BARN DOOR HARDWARE - CONESTOGA SERIES

### FEATURES

- Durable powder-coated black rail and Conestoga Style, Barn Door Hangers
- Conforms to ANSI BHMA A156.14-2007
- Grade 1 for sliding doors by exceeding 100,000 cycles in operation

### SPECIFICATIONS

- Door weight up to 250 lbs.
- Wood doors up to 1-3/4" thick

### SLIDING BARN DOOR



Stock Number	Hager Part Number	Description
<b>Conestoga Barn Door</b>		
<b>Rail Only</b>		
186242	9450-48	48" Black Powder Coated, Flat Rail
186243	9450-72	72" Black Powder Coated, Flat Rail
186251	9450-96	96" Black Powder Coated, Flat Rail
<i>Hanger Kits Less Rail, All Kits Include two carriers, stops, floor guide and rail mounting brackets and fasteners</i>		
188467	9452	3" Black Powder Coated Hook Carrier Kit Less Rail
188468	9453	5" Black Powder Coated Hook Carrier Kit Less Rail
188469	9454	3" Black Powder Coated Strap Carrier Kit Less Rail
188470	9455	3" Black Powder Coated Top Mount Carrier Kit Less Rail
<b>Optional Components</b>		
<b>Privacy Latch and Pull</b>		
186296	1-269-8693	Sliding Door Privacy Latch & Strike Plate
186299	1-269-8694	4" x 1-3/4" x 7/16" Flush Pull
<b>Accessories</b>		
186289	1-269-8689	Bracket Kit: Includes 1 Wall Mount Bracket with Fastener
186290	1-269-8690	Stop Kit: Includes 2 End Stops with Fasteners
186292	1-269-8691	Splice Kit: Includes Splice Components and Fasteners for Joint Rails



**9400 SERIES BARN DOOR HARDWARE - CONESTOGA SERIES - HOW TO ORDER**

**IMPORTANT:**

- 1.Track is ordered separately from hardware kit.
- 2.Track and Carrier Hardware are shipped in separate cartons.

**Single Door Solution:**

- 1) **9450 Track:** Specify length (48", 72" or 96").

**Example:**

- 9450 - 48
- 9450 - 72
- 9450 - 96

- 2) **Carrier Hardware Kit:** Specify style – Includes all mounting hardware

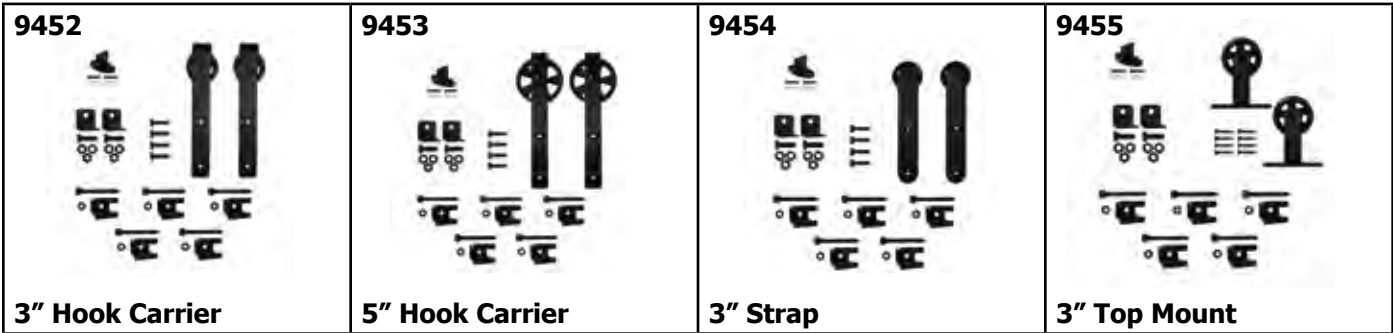

**Bi-Part Door Solution:**

If using two doors that are 3' wide, order a 6' track per door, for a total of 12'. This allows the doors to clear the door opening when in the open position. Order one carrier hardware kit per door and one Splice Kit.

**To Order:**

- 1) **9450 Track:** Specify quantity and length.
- 2) **Carrier Hardware Kit:** Specify quantity and carrier style. Example: Order 2 of part number 9453, 5" hook carrier style – Includes all mounting hardware.

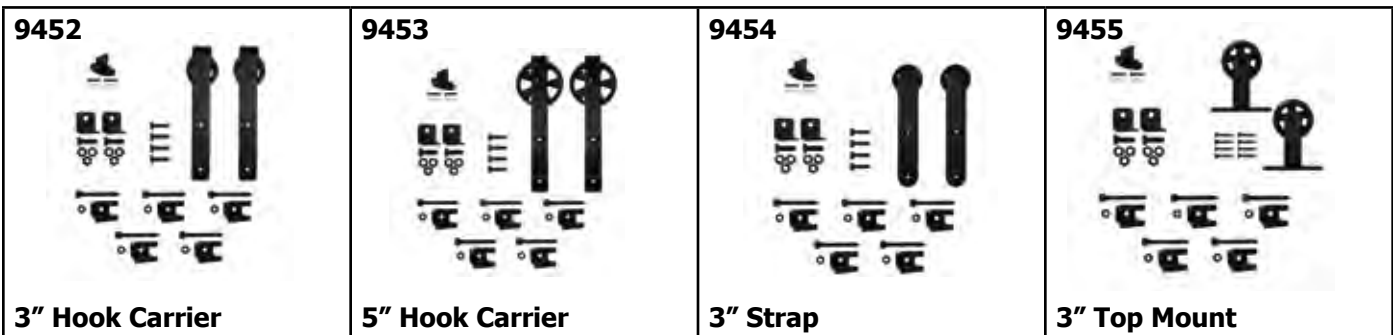

- 3) **Splice Kit:** Order 1 of part number 1-269-8691 Flat Rail Splice Kit.





## 9400 SERIES BARN DOOR HARDWARE - CONESTOGA SERIES

### 9450 Durable Black Powder-Coated Rail

#### FEATURES

Materials:	Durable powder-coated black aluminum
Available in:	48", 72" and 96" lengths



### 9452 3" Hook Carrier (Rail Not Included)

#### FEATURES

Materials:	Durable powder-coated black aluminum
System Includes:	<ul style="list-style-type: none"> <li>• Two carriers</li> <li>• Two stops</li> <li>• Floor guide</li> <li>• Rail mounting brackets and fasteners</li> </ul>
Standards:	Meets performance requirements of ANSI/BHMA 156.14 (Grade 1) for sliding doors by exceeding 100,000 cycles



#### DOOR SPECIFICATIONS

- Door weight up to 250 lbs.
- Wood doors up to 1-3/4" thick

### 9453 5" Hook Carrier (Rail Not Included)

#### FEATURES

Materials:	Durable powder-coated black aluminum
System Includes:	<ul style="list-style-type: none"> <li>• Two carriers</li> <li>• Two stops</li> <li>• Floor guide</li> <li>• Rail mounting brackets and fasteners</li> </ul>
Standards:	Meets performance requirements of ANSI/BHMA 156.14 (Grade 1) for sliding doors by exceeding 100,000 cycles



#### DOOR SPECIFICATIONS

- Door weight up to 250 lbs.
- Wood doors up to 1-3/4" thick



**9400 SERIES BARN DOOR HARDWARE - CONESTOGA SERIES**

**9454  
3" Strap Carrier (Rail Not Included)**

**FEATURES**

- |                  |  |
|------------------|--|
| Materials:       | Durable powder-coated black aluminum   |
| System Includes: | <ul style="list-style-type: none"> <li>• Two carriers</li> <li>• Two stops</li> <li>• Floor guide</li> <li>• Rail mounting brackets and fasteners</li> </ul> |
| Standards:       | Meets performance requirements of ANSI/BHMA 156.14 (Grade 1) for sliding doors by exceeding 100,000 cycles   |

**DOOR SPECIFICATIONS**

- Door weight up to 250 lbs.
- Wood doors up to 1-3/4" thick



**9455  
3" Top Mount Carrier (Rail Not Included)**

**FEATURES**

- |                  |  |
|------------------|--|
| Materials:       | Durable powder-coated black aluminum   |
| System Includes: | <ul style="list-style-type: none"> <li>• Two carriers</li> <li>• Two stops</li> <li>• Floor guide</li> <li>• Rail mounting brackets and fasteners</li> </ul> |
| Standards:       | Meets performance requirements of ANSI/BHMA 156.14 (Grade 1) for sliding doors by exceeding 100,000 cycles   |

**DOOR SPECIFICATIONS**

- Door weight up to 250 lbs.
- Wood doors up to 1-3/4" thick

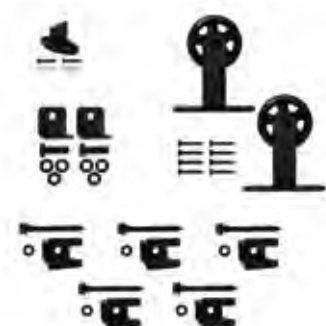



**9400 SERIES BARN DOOR HARDWARE - CONESTOGA SERIES - OPTIONAL COMPONENTS**



**1-269-8689**  
Bracket Kit



**1-269-8693**  
Privacy Latch



**1-269-8690**  
Stop Kit



**1-269-8694**  
Flush Pull



**1-269-8691**  
Splice Kit



**One Family. One Brand. One Vision.™**

[www.hagerco.com](http://www.hagerco.com)





## The Original

Hager Companies has been manufacturing the original Continuous Geared Aluminum Hinges for over 25 years. The unique design of Roton® consists of three important parts: an internal rolling contact gear profile, a high-strength cover channel and solid bearings made of celanex. Working together, these parts evenly distribute door weight and maintain door alignment for superior performance.

## Lifetime Warranty

Hager Companies offers a lifetime warranty. We believe in our product line and warrant our Roton® aluminum continuous geared hinges are free of any defects and take pride in our workmanship. As long as the hinges are installed according to our instructions, the hinges will not fail under normal usage.

## Fire-Rated Bearings

To make it easy for our customers to purchase our Roton® Continuous Geared Aluminum Hinge, we provide fire-rated bearings for all fire-rated hinges. The UL stamp denotes the hinge is fire-rated. Best of all we do not charge for this.

## Friction Free

Roton® Continuous Geared Aluminum Hinges are lubricated to eliminate the need for any assistance in maintaining a quiet performance.

## LEED/Green Requirements

Environmentally-friendly building means thinking about every detail. Roton® hinges meet LEED requirements as they are made of recycled material.

## Table of Contents

Product Information .....	2
General Information .....	6
Door and Frame Dimensioning .....	8
Electric Hinge Modifications .....	11
500 Series .....	16
750 Series .....	19
780 Series .....	21
1200 Series .....	45

## PRODUCT INFORMATION

### Door and Frame Preparation

All Roton® continuous geared hinges are surface applied. Cutout design and spacing coordination is thereby eliminated in both new construction and restoration work. Reinforcement plates are not required in doors or frames except where the gauge is too thin for the fasteners in relation to the door weight or where abusive operation is anticipated. Blank frames may be ordered with strike prep only or with a strike prep furnished on both sides to eliminate handing with any Roton® model that will cover the frame rabbet. Doors should always be ordered without cutouts except for use in labeled openings in which the tested door assembly may have manufacturing restrictions. Continuous frame mortar guards are desirable for masonry walls to avoid screw fastener interference with the mortar. An effective mortar guard made from an ordinary 1" (25 mm) x 2" (51 mm) stud, fastened to the back side of the frame can also be used. Check with both the frame supplier and the contractor for the best method. The main cause of door and frame breakdown is "kickback shock" transferred to conventional butt hinges or pivots. Installing Roton® hinges bond the door frame into a single, integrated unit, dissipating impact loads harmlessly.

### Door Closers

Conventional surface or concealed sliding closers may be used with Roton®. (Note: Pivot type floor closers with a fixed, conflicting pivot point may not be used.) Closers will last considerably longer, adjust to operating requirements more readily and show consistent settings due to the reduced operating forces of Roton® hinging.

### Standard Finishes

Roton® hinges are available in either satin etched, clear anodized aluminum (similar to US28), or dark bronze exterior anodized coating.

### Special Anodizing

Roton® hinges are available in various colors, including black, and gold, as well as other anodized finishes with fasteners to match. Final assembly must be completed by Hager because of special non-removable metal coatings applied to all hinges during assembly. Users are cautioned against attempting to refinish any Roton® product. All hinges ordered in special colors should be ordered at the same time to guarantee finish uniformity. Supply color chip for best match.

### Painted Hinges

Hager can supply unfinished materials to selected finishers for special projects which require unusual colors or coatings, but require final assembly be completed by Hager. Because of special non-removable metal coatings applied to all hinges during assembly, users are cautioned against attempting to refinish any Roton® product.

### Standard Lengths

Roton® hinge standard lengths are for 6'8" doors - 79", for 7' doors - 83", for 7'2" doors - 85", for 8' doors - 95" and for 10' doors - 119", for convenience in application to nominal doors. This provides for threshold clearance, head clearance and door height allowances for carpeting. Other lengths may be ordered as non-standard items.

Roton® hinges are always installed flush with the top edge of the door. Recommended 1/8" (3 mm) for head clearance. Where multiple net heights are likely to appear on the same job, group the sizes to 1/2" (13 mm) increments to be consistent in appearance. Generally, up to 1/2" (13 mm) of door heel exposure is acceptable, but all Roton® hinges should be within 1".

### Extra Long Hinges

Hager Companies manufactures hinges over 119" (3023 mm) long as two separate lengths with a staggered joint for onsite connection. Hager will select hinge segment lengths from standard sizes for best economics in relation to quantity required. Handing specifications are required to position the cuts inconspicuously and to finish symmetrical pairs in double door applications (25 mm) of the net door height.

### Non-Standard Lengths

All non-standard length Roton® hinges are trimmed from the bottom only and conform to published templates. If the desired length does not go through any screw holes, the hinge is manufactured as requested. If the desired length would cut through screw holes, the customer would have two options: Hager will suggest the closest length that does not go through a screw hole. If that length is not acceptable and the project requires the exact length specified, the item becomes an industrial part and the interfering screw holes would be eliminated. If the desired length would cut through bearings slots, Hager will cut through the bearing slots. This would not affect the integrity of the hinge and the cover channel would cover the cut slots leaving an aesthetically pleasing product.





## PRODUCT INFORMATION

### Field Modifications

While Roton® hinges can be cut in the field, any product modifications may void all warranties. Should in the field modifications be required, cut only from the bottom of the hinge. Do not cut through bearings or screw holes. When cutting electric hinges it is extremely important to clamp both hinge leaves securely to prevent hinge “chatter” which can damage the hinge’s internal wiring. Consult Hager Technical Service before proceeding.

### Template Hinges

Hager Companies has developed templated hole patterns for Roton® hinge models in standard lengths. Drawings are available by contacting Hager Companies Customer Service or accessing the Hager website at [www.hagerco.com](http://www.hagerco.com). Due to normal variances inherent in the manufacturing process, Roton® custom length hinges are deemed by Hager to be non-templated.

### Special Hinges

Any hinge may be ordered with special hole locations for unusual frame or door conditions. Please provide specifications for each leaf when placing an order.

### Process for Choosing the Correct Roton® Model

Determine	Select
Door and frame application (flush door and frame, inset door, door thickness, door height, etc.)	Roton® model
Frequency of door cycling and weight of door	Light, standard, heavy or extra heavy duty, lead lined
Door and frame material	Fasteners
Door opening finish	Roton® finish
Fire rating requirements, if needed	With stud or without stud

### Concealed

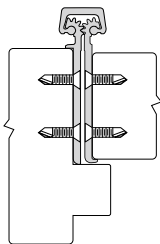

### Full Surface

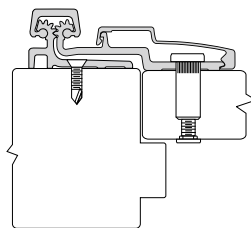

### Half Surface

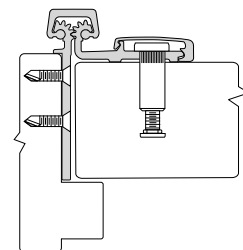

### Fire Ratings -Underwriters Laboratory Fire Rating File #A14627



780 Series Roton® continuous geared hinges with stainless steel studs are approved for use on 4'x10' metal or wood swing type doors. 780 Series Roton® continuous geared hinges without stainless steel studs are approved for use on 4'x8' single swing metal doors and 4'x10' single swing wood doors used without stainless steel studs limited to 20 minute fire rating without hose stream.

- Hollow metal, tin-clad, sheet-metal and steel covered composite type rated up to and including 3-hours
- Wood composite doors rated up to and including 1-1/2 hours
- Wood core doors rated up to 20 minutes without hose stream, non-studded
- 780 Series Roton® continuous geared hinges meet requirements for positive pressure UL10C, UL10B and UBC7-2 Part 1

## PRODUCT INFORMATION

UL10C Fire-Rated Roton®	Fully Concealed	Full Surface	Half Surface	NOTES: 1. All Roton® hinges will be marked with UL stamp if they are fire-rated.  2. Several hinge models cannot be fire-rated. Check each profile.
20 Minute Fire-Rated Wood Core Door x Fire-Rated Hollow Metal Frame	UL — <b>FF STANDARD</b>			
20 Minute Fire-Rated Metal Door x Fire-Rated Hollow Metal Frame	UL — <b>FF STANDARD</b>			
30 Minute Fire-Rated Wood Composite Door x Fire-Rated Hollow Metal Frame	UL — <b>FF STANDARD</b>			
30 Minute Fire-Rated Metal Door x Fire-Rated Hollow Metal Frame	UL — <b>FF STANDARD</b>			
45 Minute Fire-Rated Wood Composite Door x Fire-Rated Hollow Metal Frame	UL — <b>FF STANDARD</b>			
45 Minute Fire-Rated Metal Door x Fire-Rated Hollow Metal Frame	UL — <b>FF STANDARD</b>			
60 Minute Fire-Rated Wood Door x Hollow Metal Frame	UL — <b>FF STANDARD</b>			
60 Minute Fire-Rated Metal Door x Hollow Metal Frame	UL — <b>FF STANDARD</b>			
90 Minute Fire-Rated Metal Door x Fire-Rated Hollow Metal Frame	UL — <b>FF STANDARD</b>			
90 Minute Fire-Rated Wood Composite Door x Fire-Rated Hollow Metal Frame	UL — <b>STUD REQUIRED</b> * Must Specify			
3-hour Fire-Rated Metal Door x Fire-Rated Hollow Metal Frame	UL — <b>STUD REQUIRED</b> * Must Specify			

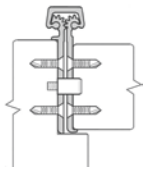

### Fully Concealed with Stud

These models are concealed between the frame and the hinge edge of the door. Models available include: 780-041HD, 780-041LL, 780-110HD, 780-111, 780-111HD, 780-111LL, 780-112, 780-112HD, 780-112LL, 780-124HD, 780-124LL, 780-224, 780-224HD, 780-224LL, 780-226, 780-226HD, 780-226LL, and 780-235HD.

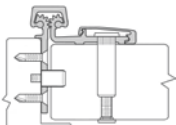

### Half Surface with Stud

These models have the frame leaf concealed between the frame and the edge of the door. The door leaf is mounted to the door with thru-bolts or screws. Models available include: 780-045HD, 780-046HD, 780-053, 780-053HD, 780-054HD, and 780-211HD.

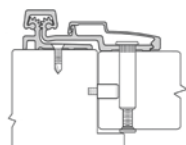

### Full Surface with Stud

These models have the frame leaf mounted to the face of the frame and the face of the door. The door leaf is mounted to the face of the door with thru-bolts. Models available include: 780-057HD, 780-157, 780-157HD, 780-210, 780-210HD, and 780-257HD.

### Checking the Load

To assist in the selection of an appropriate Roton® hinge series, divide the door weight including the weight of the hardware by the number of bearings in the Roton® hinge under consideration, then use the following guideline, with a maximum 4'0" wide door:

750 Series:	5-1/8" Centers	(Typical 7' door: 16 bearings)
780 Series:	5-1/8" Centers	(Typical 7' door: 16 bearings)
780 HD & LL:	2-9/16" Centers	(Typical 7' door: 32 bearings)

Frequency	Load
Low frequency interior doors	20 lbs. per bearing
Low frequency, very heavy doors (lead lined x-ray doors, ballistics doors, high security doors) with double rows of fasteners	30 lbs. per bearing
Medium frequency interior doors	15 lbs. per bearing
Medium frequency exterior doors	10 lbs. per bearing
High frequency exterior doors	7.5 lbs. per bearing
Very high frequency doors	5 lbs. per bearing





## PRODUCT INFORMATION

### Painted Cover Channels

Painted Roton® cover channels in bone white are offered as a standard stock color option. This is only available on the standard Roton cover channel.

### Polished Cover Channels

Any Roton® hinge may be ordered with a polished clear cover channel (similar to US26) to complement clear anodized hinge leaves or a polished gold cover channel (similar to US3) to complement satin gold anodized hinge leaves.

Roton® Cover Channel Compatibility		
Hinge Model	Flat FBCC	Round RBCC
750-134	•	•
750-138	•	•
780-041	•	•
780-045	•	•
780-046	•	•
780-053	•	•
780-054	•	•
780-057	•	•
780-110	•	•
780-111	•	•
780-112	•	•
780-113	•	•
780-114	•	•
780-155	•	•
780-157	•	
780-208	•	
780-210	•	•
780-211	•	•
780-213	•	•
780-224	•	•
780-226	•	•
780-235	•	•
780-257	•	
780-259	•	•
780-300	•	
1200-600	•	
1200-650	•	

### Rounded Back (RBCC)

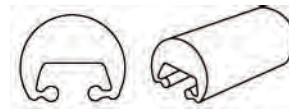

## GENERAL INFORMATION

### Bearing At Top

This application allows for the bearing to be set at the very top of the cover channel. The cover channel is flush with the top of the geared hinge, preventing any obstructions or debris to be inserted in the top channel.

### Hospital Tip

Concealed models only can be prepared with a cover channel tapered at 45° angle at the top of the hinge. These are ideal for use in hospitals and correctional facilities to help provide a clean and safe environment. Please consult the sales office for available models.

### Tamper Resistant Hinge

This application is intended for use in hospital psychiatric areas and places of high security. The hinge is prepared with a hospital tip (concealed models only) and every other bearing is supplied with a set screw to lock against the inside of the cover channel for additional security.

### Dutch Door Hinges

Hager Companies will prepare any of its hinge models for a dutch door application. The frame leaf is furnished as a continuous extrusion and the door leaf is cut to fit the dutch door heights specified. Hanging, overall net door height, amount of clearance between the top and bottom doors, their individual heights and door and frame materials should be clearly specified.

### Special Holes

Any hinge may be ordered with special hole locations for unusual frame or door conditions. Please provide specifications for each leaf.

### Bearing Replacement Kits

Available in standard or heavy duty and in clear anodized or dark bronze anodized finish for 780 and 1200 Series Roton®.

#### Marking Jigs

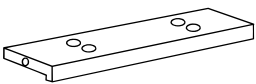

Marking jigs are available to locate the centers of the top end frame screws. These jigs must be ordered at the same time as the hinges to ensure fabrication accuracy.

#### Center Punches

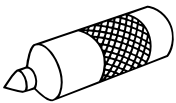

Self-centering punches are available for #12 countersunk screws that are supplied. To make sure screw heads seat properly, accurate center punching is required.

#### Shim Stock

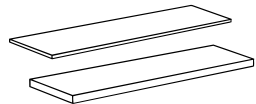

For clearance between the door and frame that may be excessive, a continuous shim is helpful (applied behind the frame leaf only). Anodized aluminum extrusions are supplied with no holes.

#### Item Marking

Marking and special packaging for job-site identification.

### Replacement Moldings

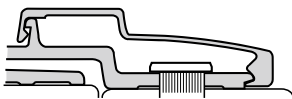

#### 780-210M

Replacement door leaf molding for 780-210, 780-210HD, 780-211, 780-211HD, 780-213HD, 780-045HD, and 780-046HD. Furnished with Allen head set screw and wrench. Shipped in standard lengths for trimming in the field.

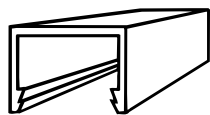
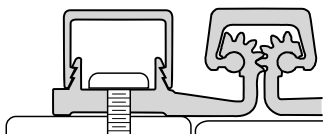

#### 780-247M

Replacement frame leaf molding for 780-157, 780-157HD, and 780-257HD. Shipped in standard lengths for trimming in the field.

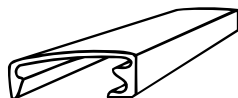
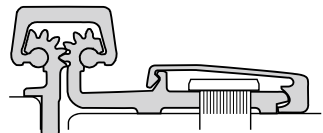

#### 780-052M

Replacement door leaf molding for 780-053, 780-053HD, 780-054HD, 780-155HD, 780-057, 780-057HD, 780-157, 780-157HD, 780-257HD, and 780-259HD. Furnished with Allen head screw and wrench. Shipped in standard lengths for trimming in the field.

## GENERAL INFORMATION

### Fasteners

Hager Companies uses custom made, carefully engineered, and thoroughly tested fasteners exclusively. Each fastener is designed for ease of use as well as durability. Appropriate fasteners are furnished with each hinge, together with installation instructions for typical metal or wood doors and frames. The standard screw pack includes self-drilling screws. If wood screws are required, please specify on order and wood screws will be substituted.

### Fasteners for Use with Hinges in the 500 Series

8 - 18 X 3/4" Truss Phillips Head Screw

### Fasteners for Use with Hinges in the 750 and 780 Series Metal Doors or Frames (Undercut Head Phillips Countersunk Screws):

Two types of screws are available for metal doors and frames: the Dril-Kwik® screw (with drill point tip) and the thread forming screw (no tapping necessary). The #12-24 x 11/16" self-drilling screw has a machine thread in the screw shank. The #12-24 x 13/32" thread-forming screw has a machine thread in the screw shank.

The standard screw pack contains #12-24 Dril-Kwik® self-drilling machine thread. This screw has a hardened steel drill point built into the end of the screw, allowing it to be installed without a pre-drilled hole if the metal thickness is no more than 1/8" (3.2 mm). It forms its own threads as the screw is drilled into the door or frame. It is longer than most screws of the type because of the built-in drill point.

When installing the self-drilling screw, make certain that the installer is familiar with the proper use and torque settings of a screw gun. Proper center-punching is extremely important with self-drilling screws. If center-punching is omitted or incorrectly done, the screw will "walk" in the same way as a drill bit, resulting in cocked screw heads and improperly closing hinge leaves.

The optional self-threading screw is typically used on grout filled frames to prevent bowing of the frame. This screw has a short tapered section at the tip. A drilled pilot hole (range: 0.173" to 0.185") is required prior to tapping.

Either of these screws may be used for the attachment of Roton® hinges to metal doors or frames, generally without reinforcement except in thin aluminum or with doors of very heavy weight or anticipated abuse. Both types require center-punching to ensure that the screw sits properly in the hinge leaf. Self-centering countersinking center-punches are available.

In all cases, care should be taken to ensure that no drill chips build up behind the hinge. It is best to premark the holes and drill for self-threading screws with the hinge removed, or hold the hinge very tightly against the door or frame when using the self-drilling screws.

Hinges normally requiring sex bolts will be furnished with suitable mounting holes. Blank leaves, special countersinking, or door fastening with pan-head screws are available upon request.

If special fasteners are required, customers must supply them except upon prior agreement. Please consult the factory for alternate fastener recommendations.

### Fasteners for Use with Hinges in the 1200 Series

1/4" - 20 x 1" Undercut Flat Phillips Head Screw

### Sex Bolts (Thru-Bolts)

On all applicable surface-mounted hinges, sex bolt sets are furnished in the hardware package together with a transfer punch for accurate marking of the 3/8" (10 mm) drilled holes required. The 1/4"-20 bolt has a 3/8" (10 mm) shoulder under a 9/16" (14 mm) pan head so that it can be reversed for exterior in-swing doors or for additional security.

Roton® sex bolts are intentionally designed to be shorter than the door thickness for proper clamping action with doors of slightly varying thickness and gauge in the 1" (25 mm) - 2-1/2" (63.5 mm) range. Unless otherwise requested, bolts suitable for the 1-3/8" (35 mm) - 1-3/4" (45 mm) range will be shipped. Shorter or longer bolts may be requested. Bolts that are outside the door thickness range of 1" (25 mm) - 2-1/2" (63.5 mm) must be provided by the installer.

## DOOR AND FRAME DIMENSIONING

### Half Surface Models

780-045HD, 780-046HD, 780-053, 780-053HD, 780-054HD, 780-155HD, 780-211HD, 780-213HD, 780-259, 780-259HD, and 780-300HD (leaf thickness clearance not required for 780-300HD)

Designed primarily for work involving new doors and frames, one leaf concealed and one leaf surface mounted. They can also be used on retrofit work where a new door can be ordered to fit an existing frame if the existing door is made of wood and can be reduced in size to accommodate the 1/8" (3.2 mm) leaf thickness, or the frame is to be replaced and can be furnished with an oversized header.

Clearance required as follows:

#### Single Doors (Square and Beveled Edge)

A. Leaf thickness	1/8" (3.2 mm)
B. Additional allowance for frame irregularities	1/32" (0.8 mm)
C. Lockside clearance for single door	1/8" (3.2 mm)
Total	9/32" (7.2 mm)

#### Pairs of Doors (Square and Beveled Edge)

A. Leaf thickness	1/8" (3.2 mm)
B. Additional allowance for frame irregularities	1/32" (0.8 mm)
C. Edge to edge clearance (recommended)*	3/16" (4.8 mm)
D. Second allowance for frame irregularities	1/32" (0.8 mm)
E. Second leaf thickness	1/8" (3.2 mm)
Total	1/2" (12.8 mm)

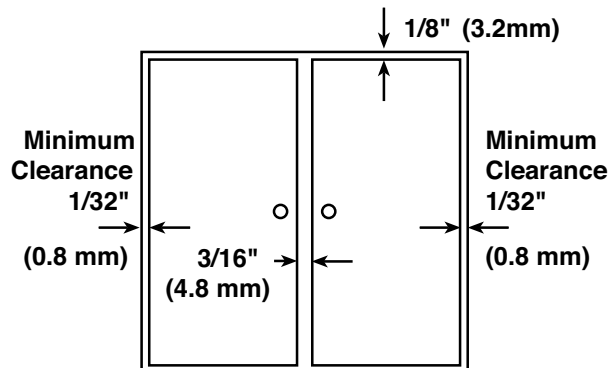
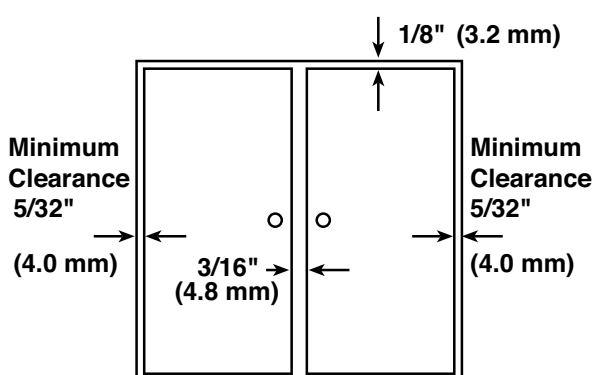
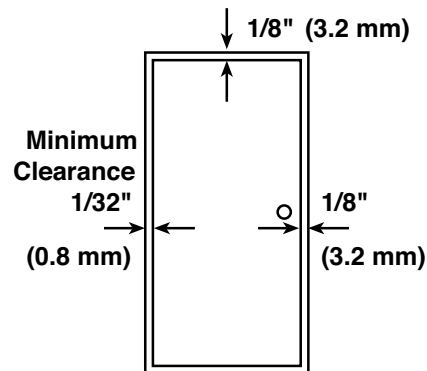
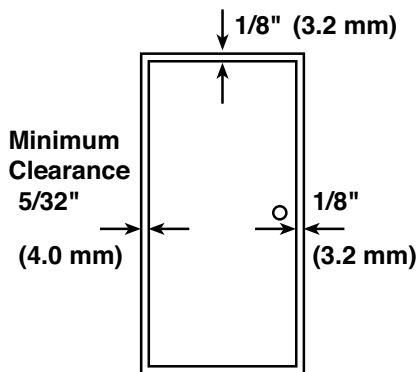

### Full Surface Models

780-057HD, 780-157, 780-157HD, 780-210, 780-210HD, and 780-257HD

The above models are designed for retrofit applications and require no special dimensioning. Full surface models are designed to be mounted to the exposed surface of the door and frame. No additional clearance is required except for door and frame painting.

Clearance required as follows:

#### Single Doors (Square and Beveled Edge)

A. Additional allowance for frame irregularities	1/32" (0.8 mm)
B. Lockside clearance for single door	1/8" (3.2 mm)
Total	5/32" (4.0 mm)

#### Pairs of Doors (Square and Beveled Edge)

A. Additional allowance for frame irregularities	1/32" (0.8 mm)
B. Edge to edge clearance (recommended)*	3/16" (4.8 mm)
C. Second allowance for frame irregularities	1/32" (0.8 mm)
Total	1/4" (6.4 mm)

\*For fire-rated doors, please refer to door manufacturer's requirement for edge to edge clearance to maintain compliance with NFPA requirements.



## DOOR AND FRAME DIMENSIONING

### Concealed Models

750-134, 750-138, 780-110HD, 780-111, 780-111HD, 780-111LL, 780-112, 780-112HD, 780-112LL, 780-124HD, 780-124LL, 780-224, 780-224HD, 780-224LL, 780-226HD, 780-226LL, and 780-235HD. The following are not recommended for doors with beveled edged applications – 780-041HD and 780-041LL.

Designed primarily for work involving new doors and frames, these models have parallel, fully concealed leaves. They can also be used on retrofit work where a new door can be ordered to fit an existing frame if the existing door is made of wood and can be reduced in size to accommodate the 5/16" (7.9 mm) hinge thickness, or the frame is to be replaced and can be furnished with an oversized header.

Clearance required as follows:

### Single Doors (Square Edged)

A. Hinge thickness	5/16" (7.9 mm)
B. Additional allowance for frame irregularities	1/32" (0.8 mm)
C. Lockside clearance for single door	1/8" (3.2 mm)
Total	15/32" (11.9 mm)

### Single Doors (Beveled Edged)

A. Hinge thickness	5/16" (7.9 mm)
B. Additional allowance for frame irregularities	1/32" (0.8 mm)
C. Lockside clearance for single door	1/8" (3.2 mm)
D. Allowance for beveled edge	1/32" (0.8 mm)
Total	1/2" (12.7 mm)

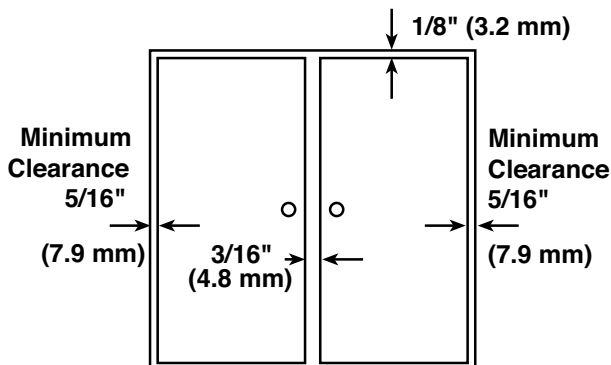
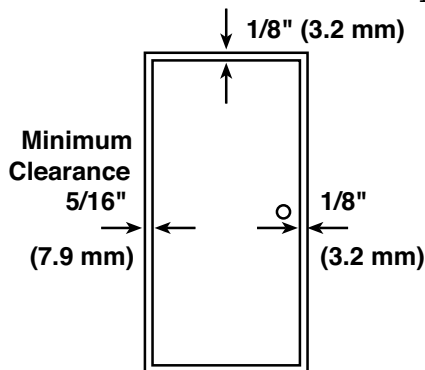

### Pairs of Doors (Square Edged)

A. Hinge thickness	5/16" (7.9 mm)
B. Additional allowance for frame irregularities	1/32" (0.8 mm)
C. Edge to edge clearance (recommended)*	3/16" (4.8 mm)
D. Second allowance for frame irregularities	1/32" (0.8 mm)
E. Second hinge thickness	5/16" (7.9 mm)
Total	7/8" (22.2 mm)

### Pairs of Doors (Beveled Edged)

A. Hinge thickness	5/16" (7.9 mm)
B. Allowance for beveled edge	1/32" (0.8 mm)
C. Additional allowance for frame irregularities	1/32" (0.8 mm)
D. Edge to edge clearance (recommended)*	3/16" (4.8 mm)
E. Second allowance for frame irregularities	1/32" (0.8 mm)
F. Second allowance for beveled edge	1/32" (0.8 mm)
G. Second hinge thickness	5/16" (7.9 mm)
Total	15/16" (23.8 mm)

### Concealed Model Exceptions - 780-113HD

#### Single Doors (Square Edged)

A. Hinge thickness	13/16" (20.6 mm)
B. Additional allowance for frame irregularities	1/32" (0.8 mm)
C. Lockside clearance for single door	1/8" (3.2 mm)
Total	31/32" (24.6 mm)

#### Single Doors (Beveled Edged)

A. Hinge thickness	13/16" (20.6 mm)
B. Additional allowance for frame irregularities	1/32" (0.8 mm)
C. Lockside clearance for single door	1/8" (3.2 mm)
D. Allowance for beveled edge	1/32" (0.8 mm)
Total	1" (25.4 mm)

### Pairs of Doors (Square Edged)

A. Hinge thickness	13/16" (20.6 mm)
B. Additional allowance for frame irregularities	1/32" (0.8 mm)
C. Edge to edge clearance (recommended)*	3/16" (4.8 mm)
D. Second allowance for frame irregularities	1/32" (0.8 mm)
E. Second hinge thickness	13/16" (20.6 mm)
Total	1-7/8" (47.6 mm)

### Pairs of Doors (Beveled Edged)

A. Hinge thickness	13/16" (20.6 mm)
B. Allowance for beveled edge	1/32" (0.8 mm)
C. Additional allowance for frame irregularities	1/32" (0.8 mm)
D. Edge to edge clearance (recommended)*	3/16" (4.8 mm)
E. Second allowance for frame irregularities	1/32" (0.8 mm)
F. Second allowance for beveled edge	1/32" (0.8 mm)
G. Second hinge thickness	13/16" (20.6 mm)
Total	1-15/16" (49.2 mm)

\*For fire-rated doors, please refer to door manufacturer's requirement for edge to edge clearance to maintain compliance with NFPA requirements.

## DOOR AND FRAME DIMENSIONING

### Concealed Model Exceptions - 780-114HD Single Doors (Square Edged)

A. Hinge thickness	15/16" (23.8 mm)
B. Additional allowance for frame irregularities	1/32" (0.8 mm)
C. Lockside clearance for single door	1/8" (3.2 mm)
Total	1-3/32" (27.8 mm)

### Pair of Doors (Square Edged)

A. Hinge thickness	15/16" (23.8 mm)
B. Additional allowance for frame irregularities	1/32" (0.8 mm)
C. Edge to edge clearance (recommended)*	3/16" (4.8 mm)
D. Second allowance for frame irregularities	1/32" (0.8 mm)
E. Second hinge thickness	15/16" (23.8 mm)
Total	2-1/8" (54.0 mm)

### 1200-600XHD, 1200-650XHD Single Doors (Square Edged)

A. Hinge thickness	15/32" (11.9 mm)
B. Additional allowance for frame irregularities	1/32" (0.8 mm)
C. Lockside clearance	1/8" (3.2 mm)
Total	5/8" (15.9 mm)

### Single Doors (Beveled Edged)

A. Hinge thickness	15/32" (11.9 mm)
B. Additional allowance for frame irregularities	1/32" (0.8 mm)
C. Lockside clearance for single door	1/8" (3.2 mm)
D. Allowance for beveled edge	1/32" (0.8 mm)
Total	21/32" (16.7 mm)

### Pair of Doors (Square Edged)

A. Hinge thickness	15/32" (11.9 mm)
B. Additional allowance for frame irregularities	1/32" (0.8 mm)
C. Edge to edge clearance (recommended)*	3/16" (4.8 mm)
D. Second allowance for frame irregularities	1/32" (0.8 mm)
E. Second hinge thickness	15/32" (11.9 mm)
Total	1-3/16" (30.2 mm)

### Pair of Doors (Beveled Edged)

A. Hinge thickness	15/32" (11.9 mm)
B. Allowance for beveled edge	1/32" (0.8 mm)
C. Additional allowance for frame irregularities	1/32" (0.8 mm)
D. Edge to edge clearance (recommended)*	3/16" (4.8 mm)
E. Second allowance for frame irregularities	1/32" (0.8 mm)
F. Second allowance for beveled edge	1/32" (0.8 mm)
G. Second hinge thickness	15/32" (11.9 mm)
Total	1-1/4" (31.8 mm)

### 780-208HD Single Doors (Square Edged)

A. Hinge thickness	1/2" (12.7 mm)
B. Additional allowance for frame irregularities	1/32" (0.8 mm)
C. Lockside clearance for single door	1/8" (3.2 mm)
Total	21/32" (16.7 mm)

### Single Doors (Beveled Edged)

A. Hinge thickness	1/2" (12.7 mm)
B. Additional allowance for frame irregularities	1/32" (0.8 mm)
C. Lockside clearance for single door	1/8" (3.2 mm)
D. Allowance for beveled edge	1/32" (0.8 mm)
Total	11/16" (17.5 mm)

### Pair of Doors (Square Edged)

A. Hinge thickness	1/2" (12.7 mm)
B. Additional allowance for frame irregularities	1/32" (0.8 mm)
C. Edge to edge clearance (recommended)*	3/16" (4.8 mm)
D. Second allowance for frame irregularities	1/32" (0.8 mm)
E. Second hinge thickness	1/2" (12.7 mm)
Total	11/4" (31.8 mm)

### Pair of Doors (Beveled Edged)

A. Hinge thickness	1/2" (12.7 mm)
B. Allowance for beveled edge	1/32" (0.8 mm)
C. Additional allowance for frame irregularities	1/32" (0.8 mm)
D. Edge to edge clearance (recommended)*	3/16" (4.8 mm)
E. Second allowance for frame irregularities	1/32" (0.8 mm)
F. Second allowance for beveled edge	1/32" (0.8 mm)
G. Second hinge thickness	1/2" (12.7 mm)
Total	1-5/16" (33.3 mm)

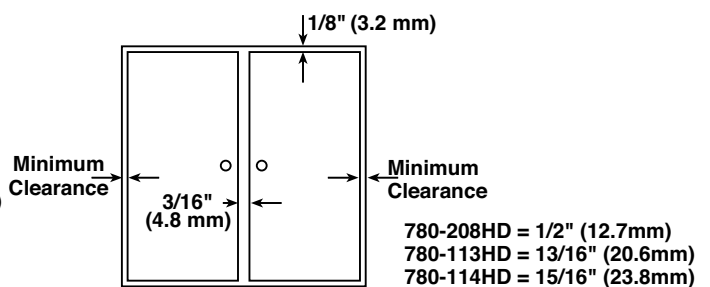
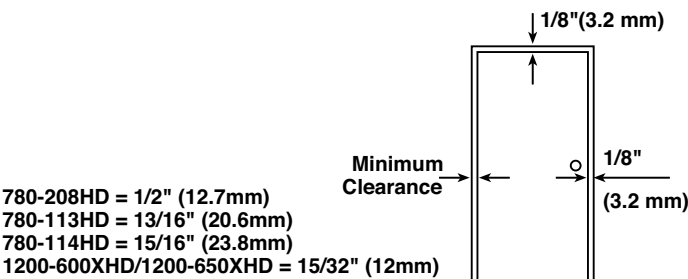

\*For fire-rated doors, please refer to door manufacturer's requirement for edge to edge clearance to maintain compliance with NFPA requirements.

## ELECTRIC HINGE MODIFICATIONS

### Concealed Electric Through-Wire and Monitoring:

- To order, use symbol "ETM" plus the number of wires required as a suffix, ie: 780-224LL 85" Bronze ETM - 4
- This combines the continuous electric conductors and the miniature switch to provide both power transfer and monitoring
- Four, six, eight or ten continuous electric conductors
- Miniature switch is incorporated into the frame leaf
- Specify handing and the dimension from the top edge of the door to the centerline of each electric modification location
- Templates regarding location of monitoring switch, available upon request

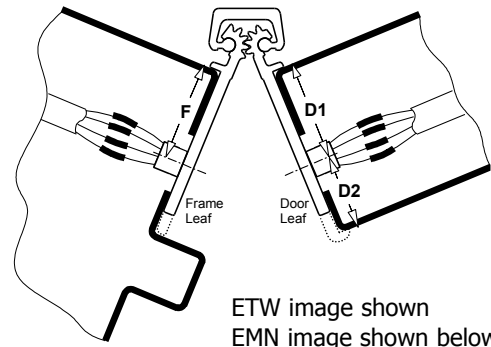

### Exposed Electric Switches

- To order, use symbol "E1S" as a suffix, ie: 780-112HD 85" Clear E1S
- Miniature push button switch is incorporated in the hinge frame leaf to monitor position of the door
- Three 12" wire leads
- Each monitoring hinge only needs one E1S switch
- Specify handing and the dimension from the top edge the door to the centerline of the electric switch location
- Templates regarding location of contact switch available upon request

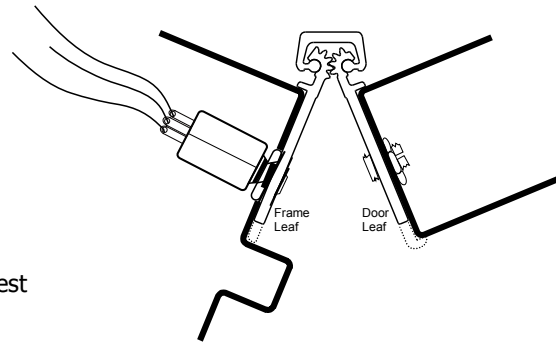

### Concealed Electric Monitoring

- To order, use symbol "EMN", as a suffix, ie: 780-224HD 119" Bronze EMN
- Miniature switch is incorporated into the frame leaf
- Three 12" wire leads
- Specify handing and the dimension from the top edge of the door to the centerline of electric monitoring location
- Templates regarding location of monitoring switch available upon request

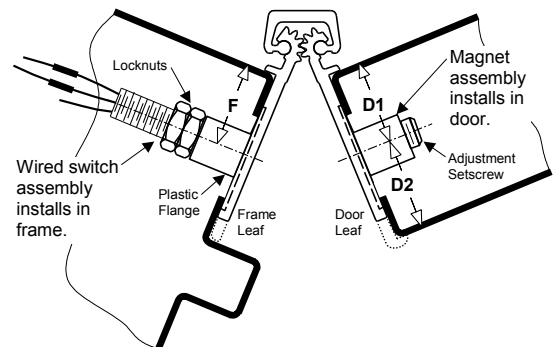

### Von Duprin EPT 2 or EPT 10 Electric Power Transfer Preparation

Concealed Leaf  
Half Surface

- Hinge leaf cutout to accommodate power transfer device
- Specify handing and the dimension from the top edge of the door to the centerline of the power transfer location

Note: Special Electric Modifications and EPT locations may require additional charges if screw holes have to be moved. Contact Hager Companies Customer Service for charges.



## ELECTRIC HINGE MODIFICATIONS

### Concealed Electric Through-Wire

- To order, use symbol "ETW" plus the number of wire leads, 12" per side required as a suffix, ie: 780-112HD 85" Clear ETW - 4
- Transfers power discreetly from building to door hardware
- 4, 6, 8, 10 or 12 wire continuous electric conductors
- Specify handing and the dimension from the top edge of the door to the centerline of electric through-wire location
- Templates regarding location of through-wires available upon request

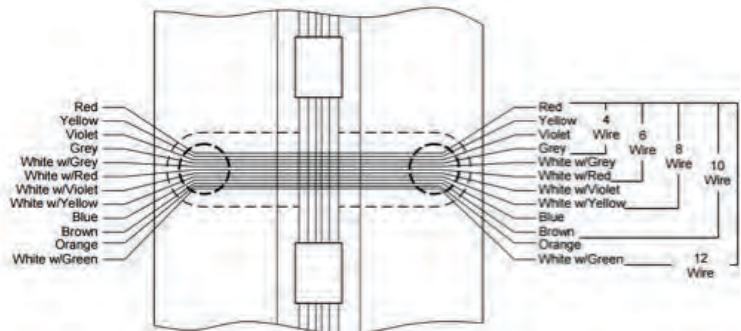

### Removable Electric Through-Wire

- To order, use symbol "RETW", ie: 780-112HD 85" Clear RETW
- Transfers power discreetly from building to door hardware
- 4" removable 10 or 12 wire ETW module can easily be removed for adjustment or service
- Available on these heavy duty models only: 780-111HD, 780-112HD, 780-124HD, 780-224HD, 780-226HD
- Specify handing and the dimension from the top edge of the door to the centerline of electric monitoring location
- Templates regarding location of module available upon request



Component #	Finish	# of Wires
7-102-1860	Clear	10
7-112-1870	Dark Bronze	10
7-112-7825	Gold	10
7-112-1875	Black	10
7-102-1870	Clear	12
7-112-1872	Dark Bronze	12
7-112-1876	Gold	12
7-112-1881	Black	12

### Mortar Box - 430

- Serves as a mortar shield
- Overall dimensions: 9" (229 mm) length with tabs, 7" (178 mm) inside, 1-3/4" x 1-3/4" (45 mm x 45 mm) inside dimension
- Galvanized steel 0.040" (1 mm)
- Top and bottom knockouts for standard conduit fittings



### Exposed Electric Contacts

- To order, use symbol "E" plus the number of contacts required as a suffix, ie: 780-112HD 85" Clear E4
- Transfers power to door in closed position
- Must have at least two contacts to transfer power
- Specify handing and the dimension from the top edge of the door to the centerline of the electric contact location
- Templates regarding location of contacts available upon request

## ELECTRIC HINGE MODIFICATIONS

### Quick Connect

Available for ETM, ETW, and RETW options. Top and bottom knockouts for standard conduit fittings.

### Concealed Electric Monitoring (EMN)

- Miniature switch is incorporated into the frame leaf.
- Specify handing and the dimension from the top edge of the door to the centerline of the electric monitoring location.
- Special Electric Modifications and EPT locations may require additional charges if screw holes have to be moved.
- Templates regarding location of monitoring switch available upon request.

### Concealed Electric Through-Wire and Monitoring (ETM)

- Electric Preparation
  - ETM-4
  - ETM-6
  - ETM-8
  - ETM-10
- All ETM have 28-gauge continuous conductors.
- This combines the continuous electric conductors and the miniature switch to provide both power transfer and monitoring.
- Miniature switch is incorporated into the frame leaf.
- Specify handing and the dimension from the top edge of the door to the centerline of each electric modification location.
- Templates regarding location of monitoring switch available upon request.

### Concealed Electric Through-Wire (ETW)

- Electric Preparation
  - ETW-4
  - ETW-6
  - ETW-8
  - ETW-10
  - ETW-12
- All ETW have 28-gauge continuous conductors.
- 12" per side required as a suffix.
- Cut out for prep - 1/2" drilled hole.
- Transfers power discreetly from building to door hardware.
- Specify handing and the dimension from the top edge of the the door to the centerline of the electric through-wire location.
- Special electric modifications and EPT locations may require additional charges if screw holes have to moved. Contact Hager Customer Service for charges.
- Templates regarding location of through-wires available upon request.

## ELECTRIC HINGE MODIFICATIONS

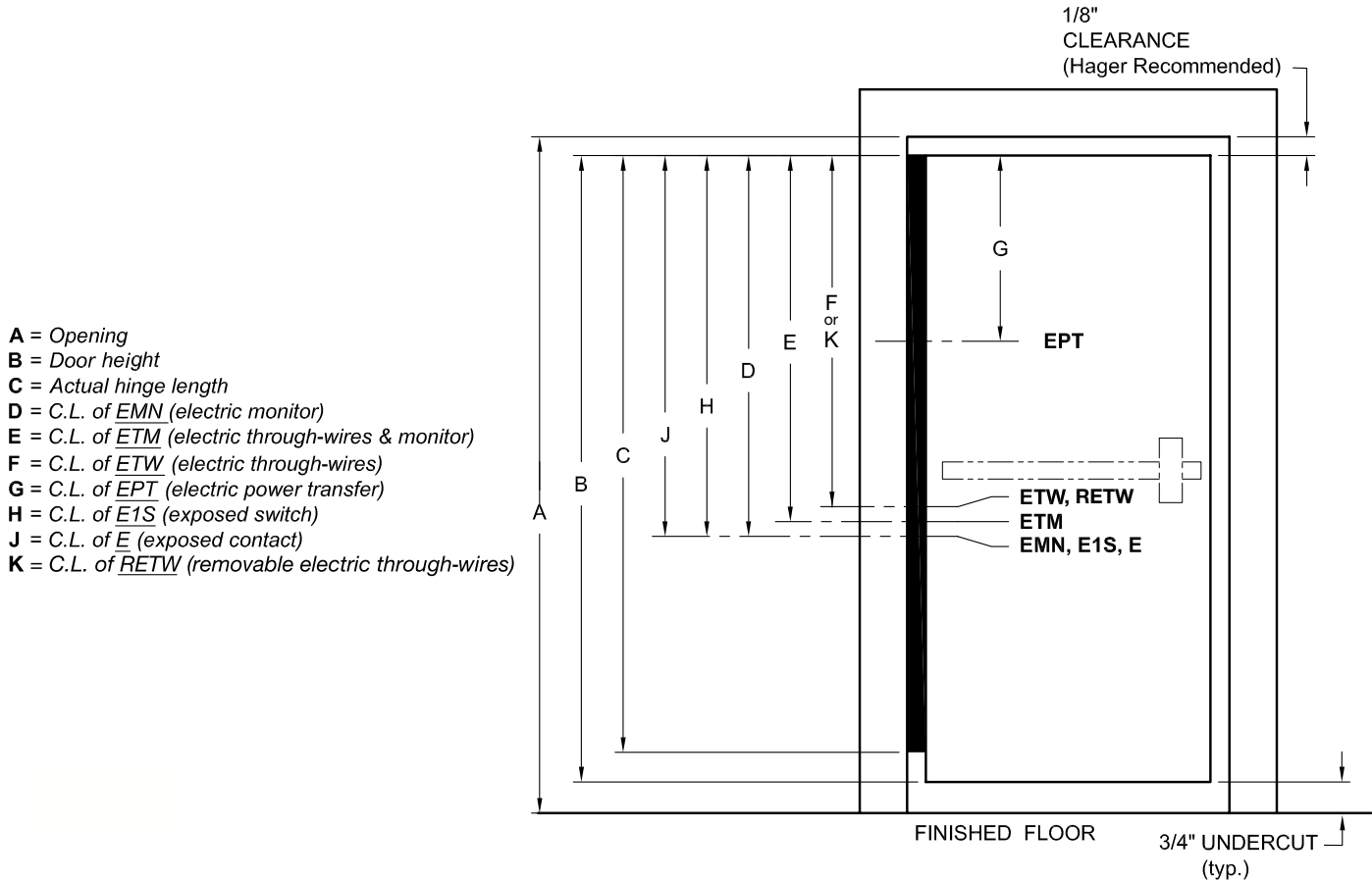

For ease of ordering, Hager Companies has established standard locations for power transfer cutouts. All standard location dimensions are referenced from the top edge of the door to the centerline of the power transfer cutout. Please specify handing.

NOTE: Full surface hinges are not available with preps.

	Opening	Door Height	Actual Hinge Length	EMN	ETM	ETW	EPT	E1S	E	RETW
79 SD	80"	79-1/8"	78-11/16"	40-3/4"	42-3/4"	40-3/4"	34-3/8"	42-1/2"	42-1/2"	-
79 HD	80"	79-1/8"	78-11/16"	40-3/4"	42-3/4"	40-3/4"	34-3/8"	42-1/2"	42-1/2"	43-11/32"
83 SD	84"	83-18"	83"	45-5/16"	44-3/4"	45-5/16"	36-3/8"	46-1/2"	46-1/2"	-
83 HD	84"	83-1/8"	83"	45-5/16"	44-3/4"	45-5/16"	36-3/8"	46-1/2"	46-1/2"	45-11/32"
85 SD	86"	85-1/8"	85"	46-5/16"	45-3/4"	46-5/16"	37-3/8"	48-1/2"	48-1/2"	-
85 HD	86"	85-1/8"	85"	46-5/16"	45-3/4"	46-5/16"	37-3/8"	48-1/2"	48-1/2"	46-11/32"
95 SD	96"	95-1/8"	95-1/16"	56-3/8"	55-13/16"	56-3/8"	47-1/2"	59-3/4"	59-3/4"	-
95 HD	96"	95-1/8"	95-1/16"	56-3/8"	55-13/16"	56-3/8"	47-1/2"	59-3/4"	59-3/4"	56-15/32"
119 SD	120"	119-1/8"	119"	81-1/4"	80-11/16"	81-1/4"	72-5/16"	83-3/4"	83-3/4"	-
119 HD	120"	119-1/8"	119"	81-1/4"	80-11/16"	81-1/4"	72-5/16"	83-3/4"	83-3/4"	81-9/32"

SD = Standard Duty

HD = Heavy Duty





## ELECTRIC HINGE MODIFICATIONS

Part Number	Von Duprin EPT 2 or EPT 10 Power Transfer Preparation	Exposed Electric Contacts	Exposed Electric Switches	Concealed Electric Through-Wire	Concealed Electric Monitoring	Concealed Electric Through-Wire and Monitoring	Removable Electric Through-Wire
	EPT	E	E1S	ETW	EMN	ETM	RETW
780-045HD	•						
780-046HD	•						
780-053	•						
780-053HD	•						
780-054HD	•						
780-057				•			•
780-110HD			•				
780-111	•	•	•	•	•	•	
780-111HD	•	•	•	•	•	•	•
780-111LL	•	•	•	•	•	•	
780-112	•	•	•	•	•	•	
780-112HD	•	•	•	•	•	•	•
780-112LL	•	•	•	•	•	•	
780-124HD	•	•	•	•	•	•	•
780-124LL	•	•	•	•	•	•	
780-157				•			•
780-224	•	•	•	•	•	•	
780-224HD	•	•	•	•	•	•	•
780-224LL	•	•	•	•	•	•	
780-226HD	•	•	•	•	•	•	•
780-226LL	•	•	•	•	•	•	
780-235HD				•			
1200-600	•			•			
1200-650	•			•			

## 500 SERIES LIGHT DUTY - 500-048 - LIGHT DUTY, CONCEALED LEAF HINGE

### SPECIFICATIONS

Material:	Aluminum 6063-T6 - 1/16" (1.5 mm) leaf thickness
Clearance:	5/16" (8 mm)
Fasteners:	#8-18 x 3/4" truss head Phillips tapping AB zinc plated steel. Painted to match. For sheet metal or wood applications.
Length Options:	Standard and custom lengths available

### FEATURES

- Universal hinge used for a wide variety of applications including marine applications, wood cabinet construction, medical equipment, portable exhibits and displays, electronic cabinets, switchboxes, etc.
- Bearings spaced to distribute door weight evenly up to 50 lbs.
- Can be used for vertical or horizontal applications
- Alignment ribs for easy installation and proper hinge location

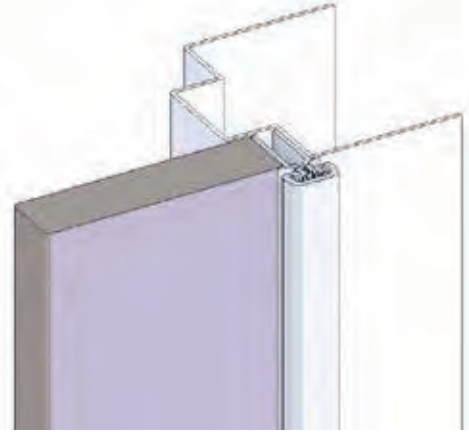

Length		Fastener Count	
Inches	Millimeters	# For Door	# For Jamb
24	610	6	6
36	914	9	9
48	1219	12	12
72	1829	18	18

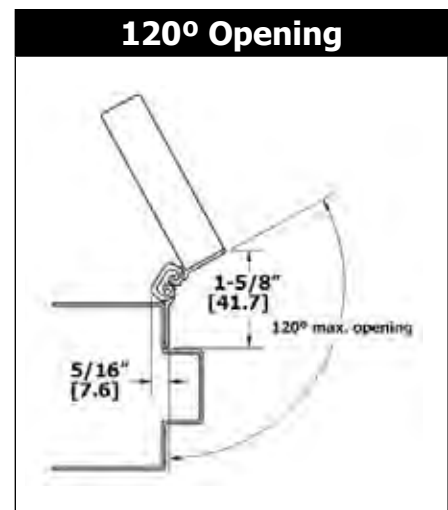
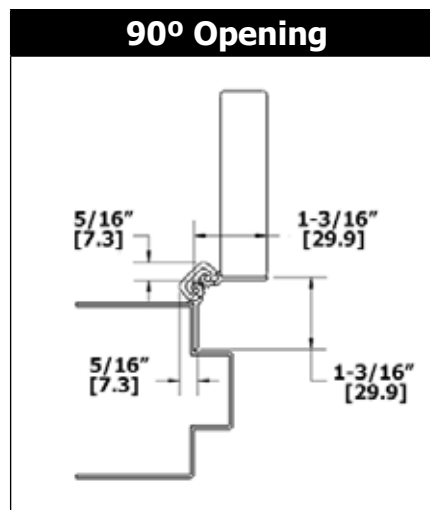
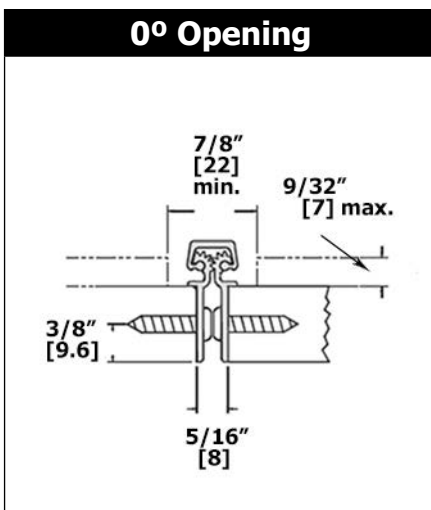





## 500 SERIES LIGHT DUTY - 500-200 - LIGHT DUTY, HALF SURFACE HINGE

### SPECIFICATIONS

Material:	Aluminum 6063-T6 - 1/16" (1.5 mm) leaf thickness
Clearance:	7/32" (5.6 mm) minimum
Fasteners:	#8-18 x 3/4" truss head Phillips tapping AB zinc plated steel. Painted to match. For sheet metal or wood applications. Shorter screws required for openings past 90° when applied as shown in "A" (not provided).
Length Options:	Standard and custom lengths available

### FEATURES

- Universal hinge used for a wide variety of applications including marine applications, wood cabinet construction, medical equipment, portable exhibits and displays, electronic cabinets, switchboxes, etc.
- Bearings spaced to distribute door weight evenly up to 50 lbs.
- Can be used for vertical or horizontal applications
- Alignment ribs for easy installation and proper hinge location

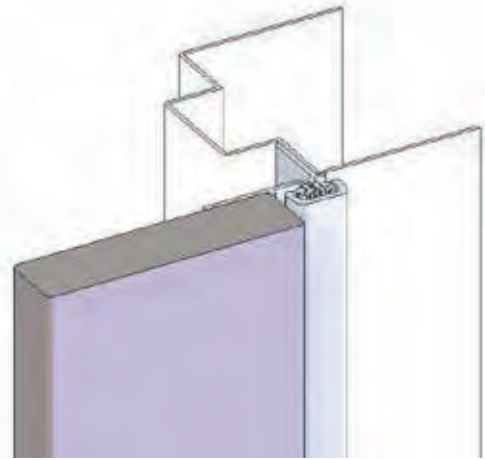

(Left hand shown)

Length		Fastener Count	
Inches	Millimeters	# For Door	# For Jamb
24	610	6	6
36	914	9	9
48	1219	12	12
72	1829	18	18

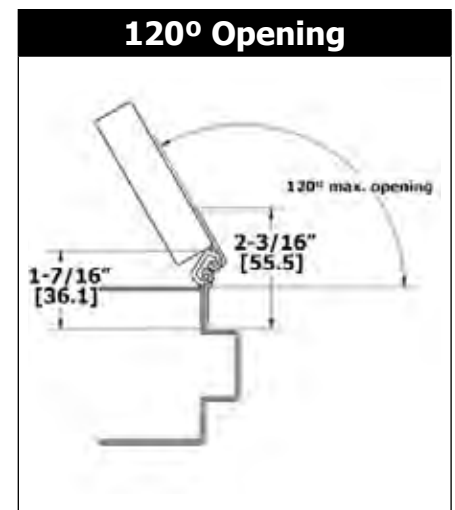
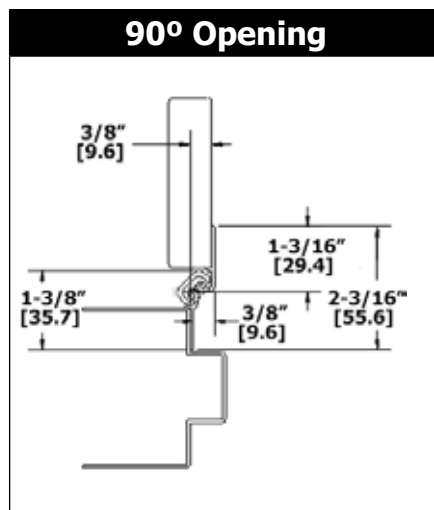
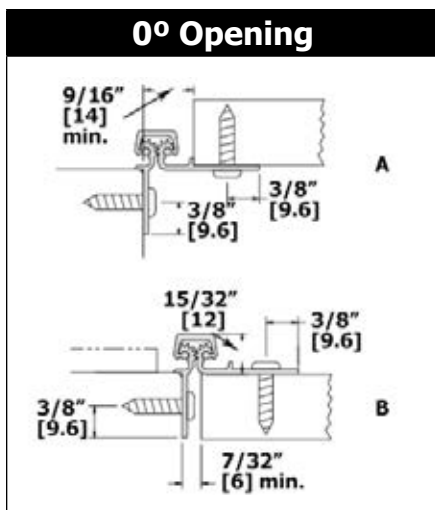

## 500 SERIES LIGHT DUTY - 500-220 - LIGHT DUTY, FULL SURFACE HINGE

### SPECIFICATIONS

Material:	Aluminum 6063-T6 - 1/16" (1.5 mm) nominal leaf thickness
Clearance:	1/32" (1 mm) minimum
Fasteners:	#8-18 x 3/4" truss head Phillips tapping AB zinc plated steel. Painted to match. For sheet metal or wood applications. Shorter screws required for 90° and 180° openings when applied. Shorter screws required for openings past 90° when applied.
Length Options:	Standard and custom lengths available

### FEATURES

- Universal hinge used for a wide variety of applications including marine applications, wood cabinet construction, medical equipment, portable exhibits and displays, electronic cabinets, switchboxes, etc.
- Allows either inset or outset applications for recessed or surface mounting
- Bearings spaced to distribute door weight evenly up to 50 lbs.
- Can be used for vertical or horizontal applications
- Alignment ribs for easy installation and proper hinge location

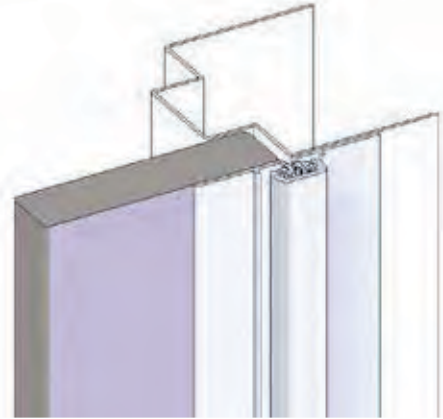

Length		Fastener Count	
Inches	Millimeters	# For Door	# For Jamb
24	610	6	6
36	914	9	9
48	1219	12	12
72	1829	18	18

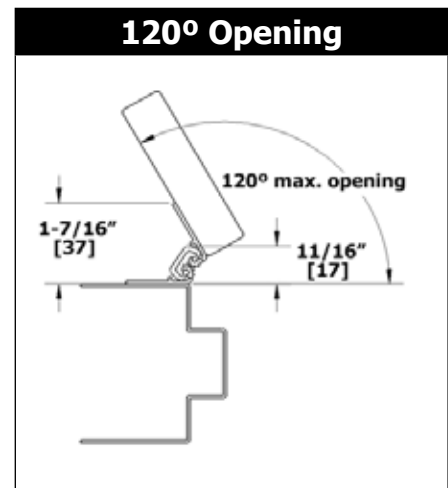
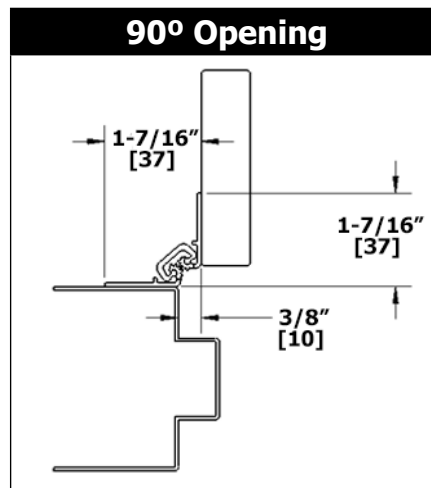
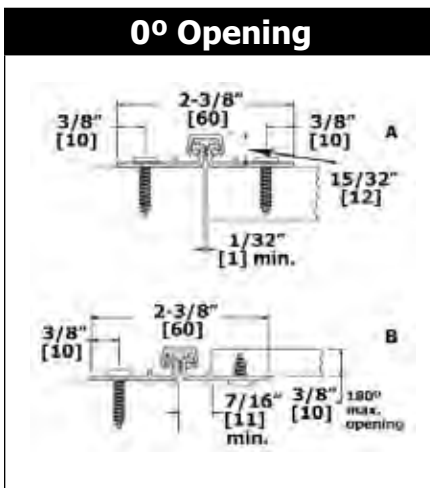



## 750 SERIES CONCEALED LEAF - 750-134 - STANDARD DUTY

### SPECIFICATIONS

Material:	Aluminum 6063-T6
Clearance:	5/16" (8 mm) hinge side plus standard lockside clearance
Fasteners:	Dril-Kwik® and wood screws
Length Options:	Standard and custom lengths available
Door/Frame Reinforcement:	None required

### FEATURES

- For medium frequency, 1-3/4" (44 mm) thick solid core wood interior doors up to 100 pounds
- Door edge protection lip
- Offset joint to clear casing
- Frame leaf alignment rib for proper hinge location

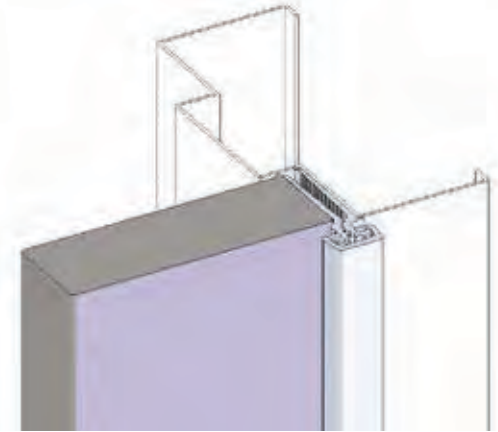

Length		Fastener Count	
Inches	Millimeters	# For Door	# For Jamb
79	2007	15	15
83	2108	19	19
85	2159	19	19
95	2413	20	20
119	3023	23	23

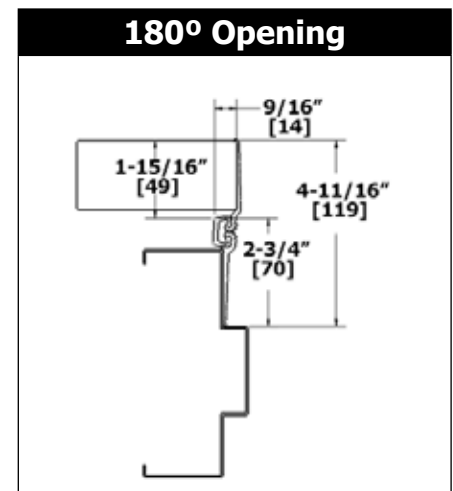
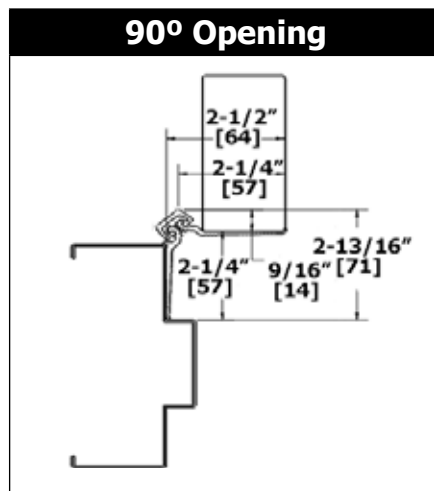
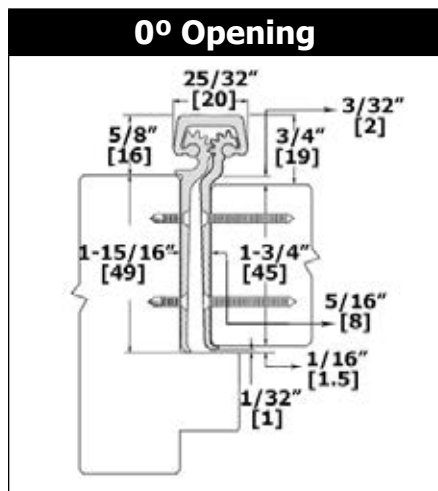

## 750 SERIES CONCEALED LEAF - 750-138 - STANDARD DUTY

### SPECIFICATIONS

Material:	Aluminum 6063-T6
Clearance:	5/16" (8 mm) hinge side plus standard lockside clearance
Fasteners:	Dril-Kwik® and wood screws
Length Options:	Standard and custom lengths available
Door/Frame Reinforcement:	None required

### FEATURES

- For medium frequency, 1-3/8" (35 mm) thick solid core wood interior doors up to 100 pounds
- Door edge protection lip
- Offset joint to clear casing
- Frame leaf alignment rib for proper hinge location

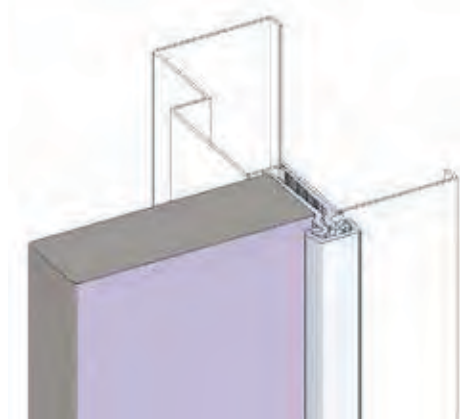

Length		Fastener Count	
Inches	Millimeters	# For Door	# For Jamb
79	2007	14	14
83	2108	18	18
85	2159	18	18
95	2413	20	20
119	3023	26	26

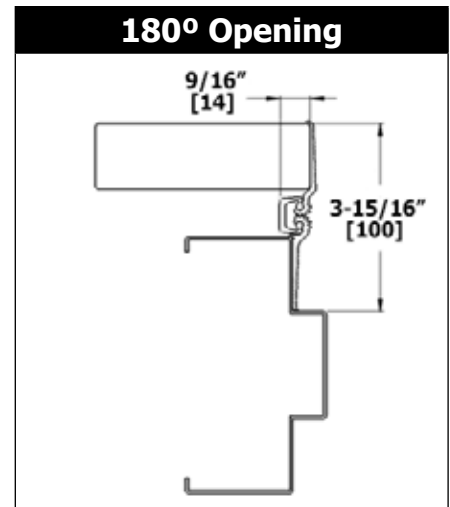
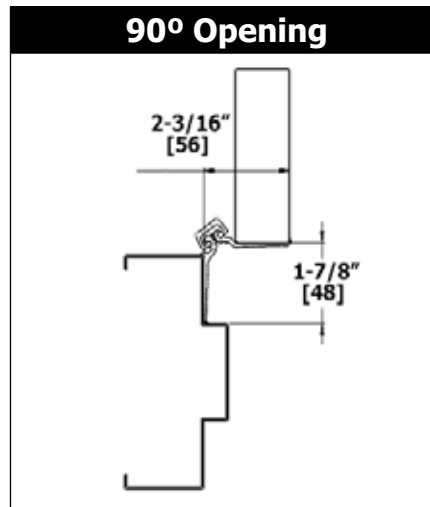
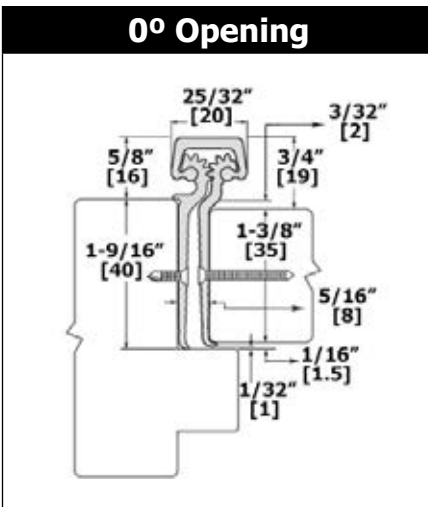



## 780 SERIES CONCEALED LEAF - 780-041HD | 780-041LL - HEAVY DUTY OR LEAD LINED

### SPECIFICATIONS

Material:	Aluminum 6063-T6
Clearance:	5/16" (8 mm) hinge side plus standard lockside clearance
Fasteners:	Dril-Kwik® screws
LL Fasteners:	1/2 Dril-Kwik® screws, 1/2 wood screws
Length Options:	Standard and custom sizes available
Door/Frame Reinforcement:	None required to 200 lbs., heavier weight use 16-gauge channel
Optional Fire Rating:	Up to 3-hour metal and 90 minute wood composite (with studs)
Notes:	See additional fire rating details on page 3

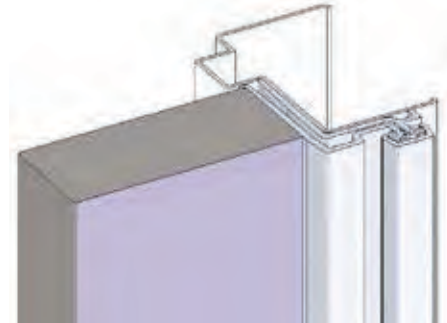

(Left hand shown)

### FEATURES

- Heavy duty for high frequency doors - for wood or metal doors 1-3/4" (44 mm) thick
- Lead lined model for hospital x-ray room doors with double row of screws to straddle lead (specify "LL")
- Door edge protection lip
- Swing-clear action and ADA compliant for classroom or patient room doors
- Not recommended for doors with a beveled edge on the hinge side

Length		Fastener Count			
Inches	Millimeters	# Per Door		# Per Jamb	
		HD	LL	HD	LL
79	2007	15	32	15	32
83	2108	19	36	19	36
85	2159	19	36	19	36
95	2413	20	42	20	42
119	3023	23	48	23	48

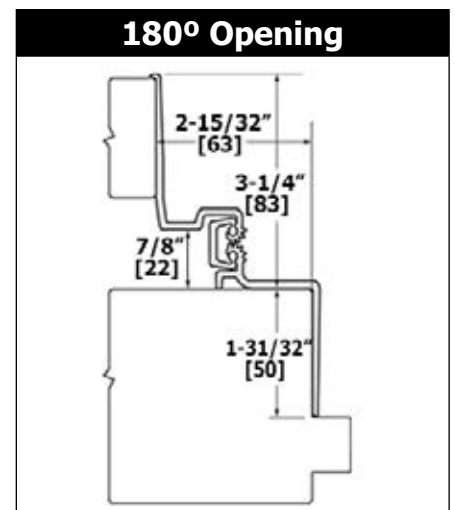
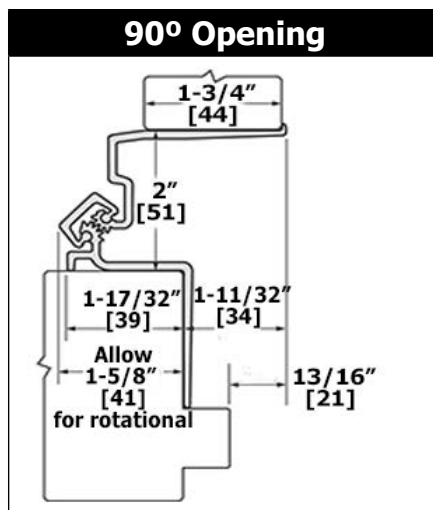
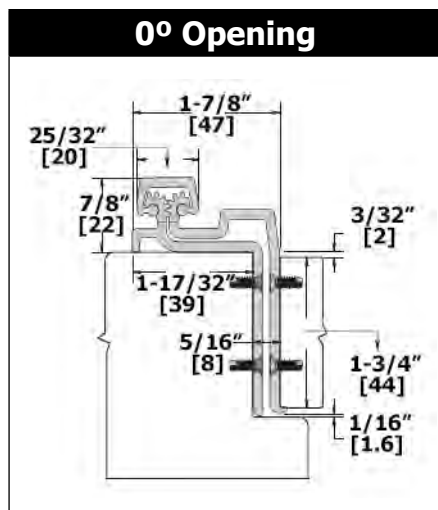

## 780 SERIES CONCEALED LEAF - 780-110HD - HEAVY DUTY

### SPECIFICATIONS

Material:	Aluminum 6063-T6
Clearance:	5/16" (8 mm) hinge side plus standard lockside clearance
Fasteners:	Dril-Kwik® screws
Length Options:	Standard and custom lengths available
Door/Frame Reinforcement:	None required to 200 lbs., heavier weight use 16-gauge channel
Notes:	See additional fire rating details on page 3

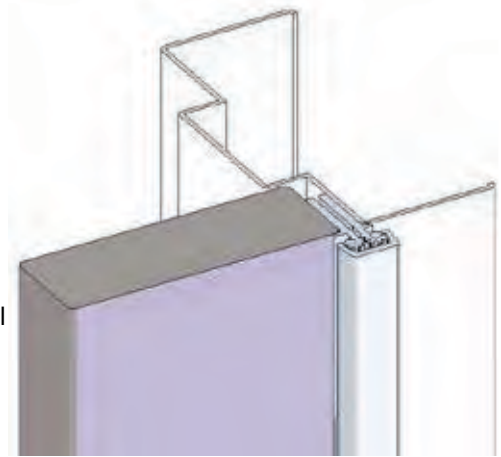

### FEATURES

- Heavy duty for high frequency doors or heavy, medium frequency doors. For doors 1" (25 mm) to 1-3/8" (35 mm) thick.
- Frame and door leaf alignment ribs for proper hinge and door location

Length		HD Fastener Count	
Inches	Millimeters	# For Door	# For Jamb
79	2007	18	18
83	2108	18	18
85	2159	18	18
95	2413	20	20
119	3023	26	26

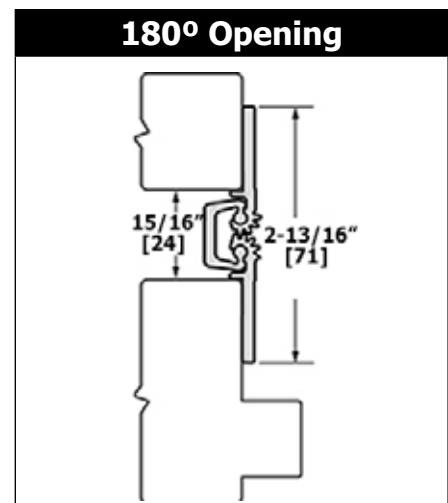
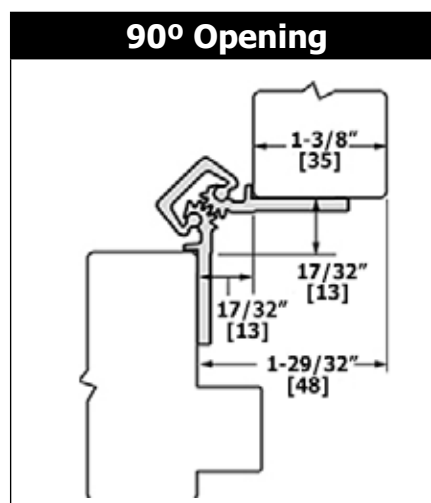
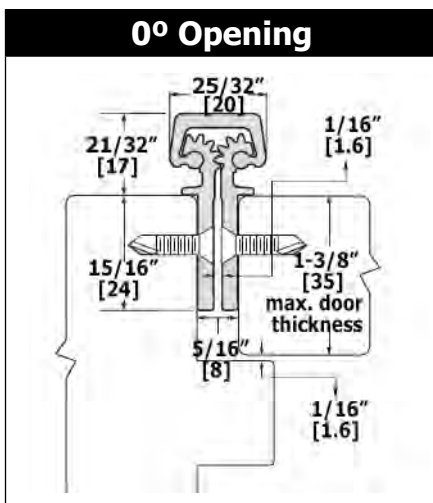



**780 SERIES CONCEALED LEAF - 780-111\* | 780-111HD\* | 780-111LL - STANDARD DUTY, HEAVY DUTY OR LEAD LINED**

**SPECIFICATIONS**

- Material: Aluminum 6063-T6
- Clearance: 5/16" (8 mm) hinge side plus standard lockside clearance
- Fasteners: Dril-Kwik® screws
- LL Fasteners: 1/2 Dril-Kwik® screws, 1/2 wood screws
- Length Options: Standard and custom lengths available
- Door/Frame Reinforcement: None required to 200 lbs., heavier weight use 16-gauge channel
- Optional Fire Rating: Up to 3-hour metal and 90 minute wood composite (with studs)
- Notes: See additional fire rating details on page 3

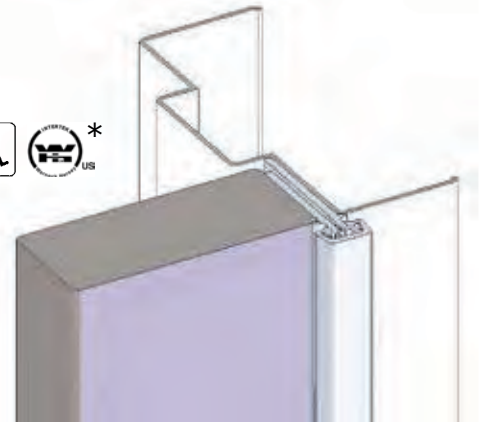

**FEATURES**

- Standard duty for medium frequency doors. Heavy duty for high frequency doors or heavy, medium frequency doors.
- Lead lined model for hospital x-ray room doors with double row of screws to straddle lead (Specify "LL")
- Frame and door leaf alignment ribs for proper hinge and door location
- 1/8" (3 mm) inset

Length		Fastener Count					
Inches	Millimeters	# For Door			# For Jamb		
		SD	HD	LL	SD	HD	LL
79	2007	15	15	32	15	15	32
83	2108	19	19	36	19	19	36
85	2159	19	19	36	19	19	36
95	2413	20	20	42	20	20	42
119	3023	23	23	48	23	23	48

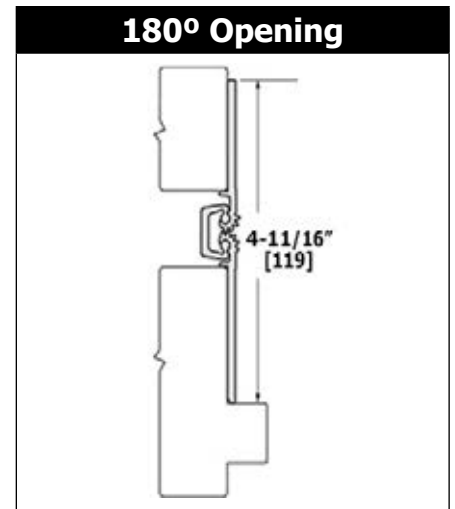
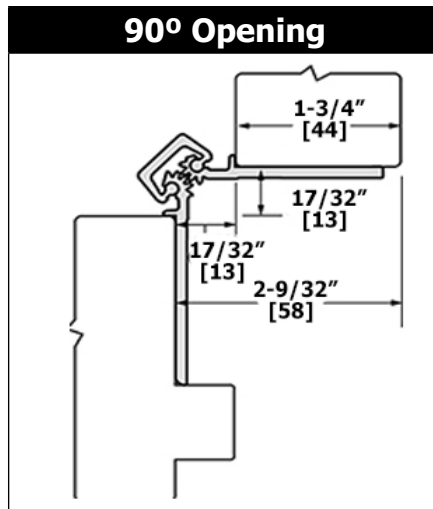
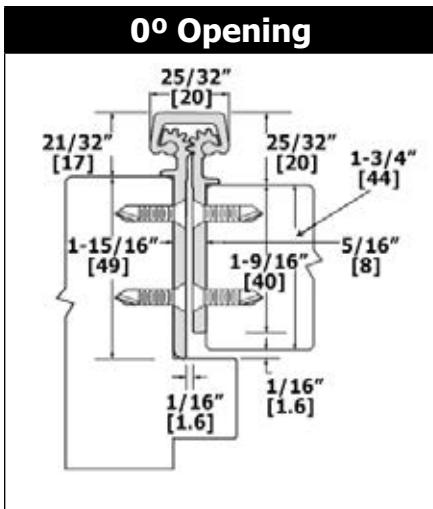

**SPECIFICATIONS**

Material:	Aluminum 6063-T6
Clearance:	5/16" (8 mm) hinge side plus standard lockside clearance
Fasteners:	Dril-Kwik® screws
LL Fasteners:	1/2 Dril-Kwik® screws, 1/2 wood screws
Length Options:	Standard and custom lengths available
Door/Frame Reinforcement:	None required to 200 lbs., heavier weight use 16-gauge channel
Optional Fire Rating:	Up to 3-hour metal and 90 minute wood composite (with studs)
Notes:	See additional fire rating details on page 3

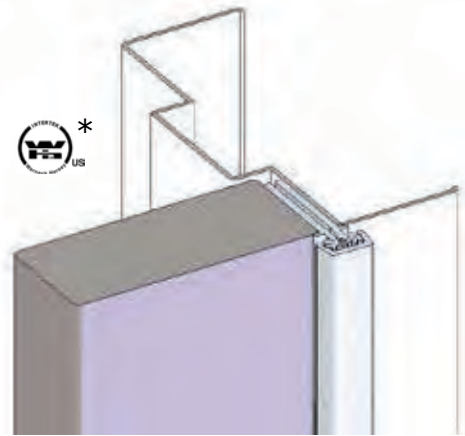

**FEATURES**

- Standard duty for medium frequency doors. Heavy duty for high frequency doors or heavy, medium frequency doors.
- Lead lined model for hospital x-ray room doors with double row of screws to straddle lead (Specify "LL")
- Frame and door leaf alignment ribs for proper hinge and door location

Length		Fastener Count					
Inches	Millimeters	# For Door			# For Jamb		
		SD	HD	LL	SD	HD	LL
79	2007	15	15	32	15	15	32
83	2108	19	19	36	19	19	36
85	2159	19	19	36	19	19	36
95	2413	20	20	42	20	20	42
119	3023	23	23	48	23	23	96

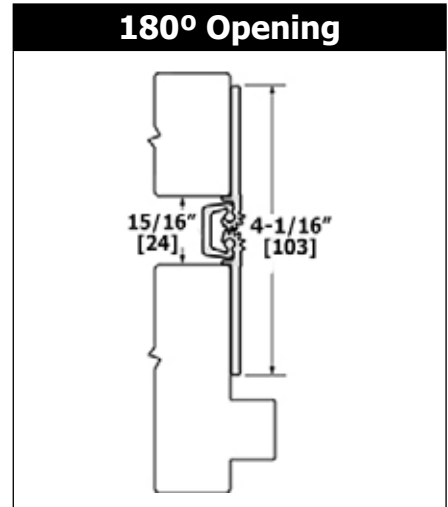
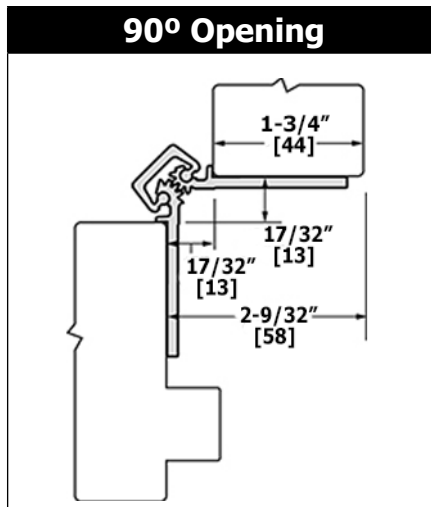
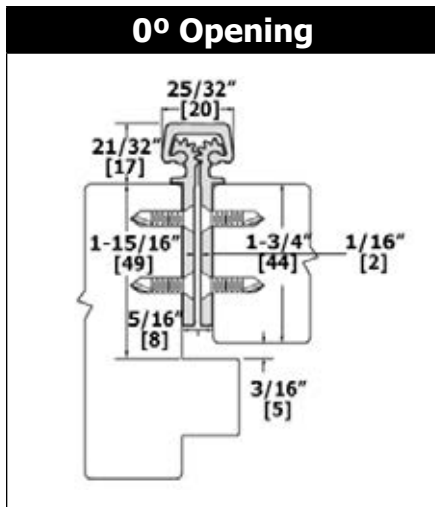





## 780 SERIES CONCEALED LEAF - 780-113HD - HEAVY DUTY

### SPECIFICATIONS

Material:	Aluminum 6063-T6
Clearance:	13/16" (21 mm) hinge side plus standard lockside clearance
Fasteners:	Dril-Kwik® screws
Length Options:	Standard and custom lengths available
Door/Frame Reinforcement:	None required to 200 lbs., heavier weight use 16-gauge channel
Notes:	See additional fire rating details on page 3

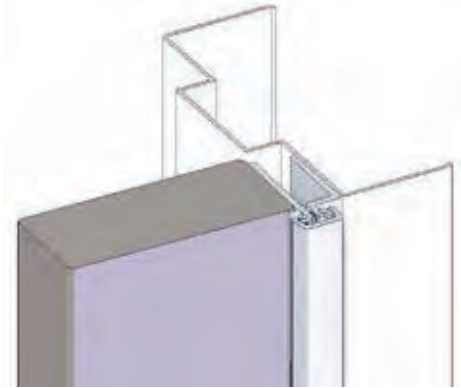

(Left hand shown)

### FEATURES

- Heavy duty for high frequency doors or heavy, medium frequency doors
- "Safety Hinge" for early education centers, nursing homes, etc. (when used without frame stop)
- Door leaf alignment rib for proper door location
- 1/16" (1.5 mm) inset

Length		HD Fastener Count	
Inches	Millimeters	# For Door	# For Jamb
79	2007	15	15
83	2108	19	18
85	2159	19	18
95	2413	20	20
119	3023	23	26

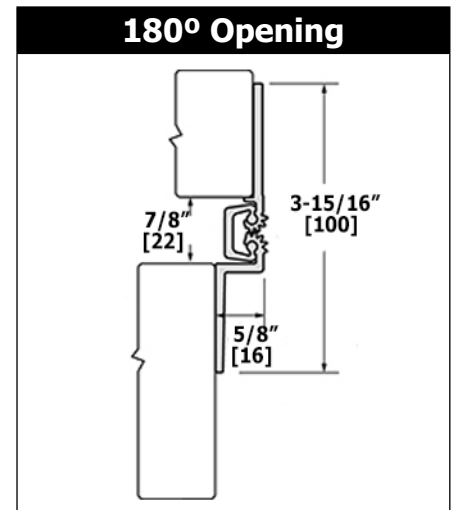
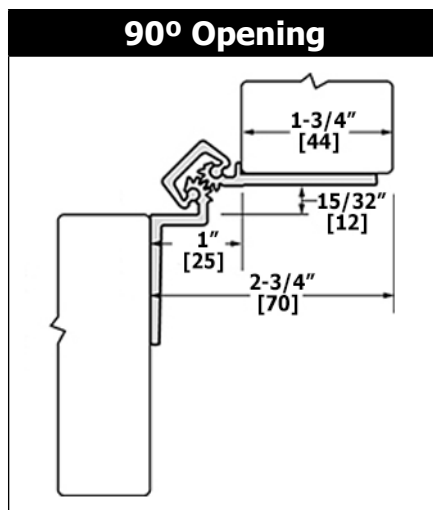
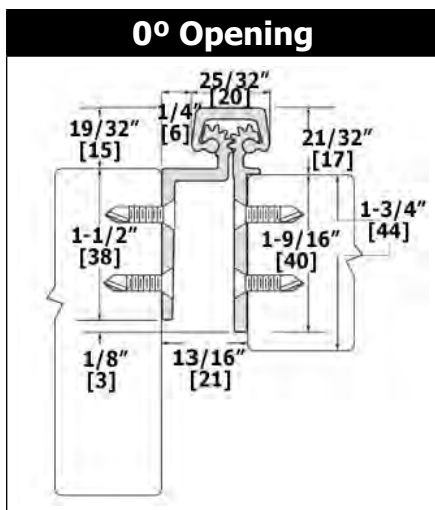

## 780 SERIES CONCEALED LEAF - 780-114HD - HEAVY DUTY

### SPECIFICATIONS

Material:	Aluminum 6063-T6
Clearance:	15/16" (24 mm) hinge side plus standard lockside clearance
Fasteners:	Dril-Kwik® screws
Length Options:	Standard and custom lengths available
Door/Frame Reinforcement:	None required to 200 lbs., heavier weight use 16-gauge channel

### FEATURES

- Heavy duty for high frequency doors or heavy, medium frequency doors
- For deep inset or flush-with-frame (when using rabbeted frames) applications, center hung doors, heavy cabinets
- For square edged doors on hinge side

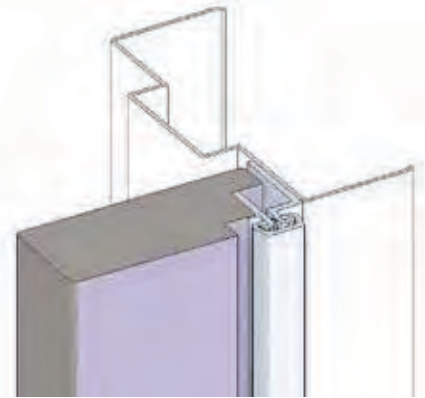

(Left hand shown)

Length		HD Fastener Count	
Inches	Millimeters	# For Door	# For Jamb
79	2007	16	16
83	2108	18	18
85	2159	18	18
95	2413	20	20
119	3023	26	26

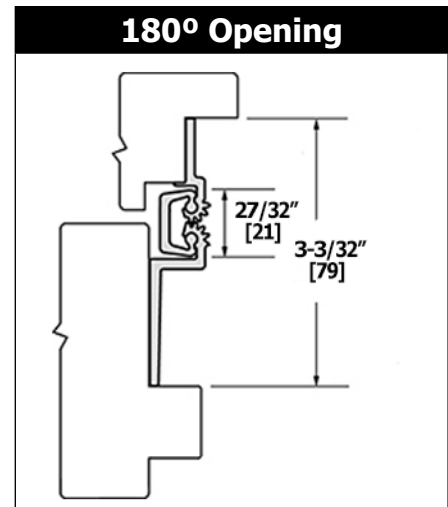
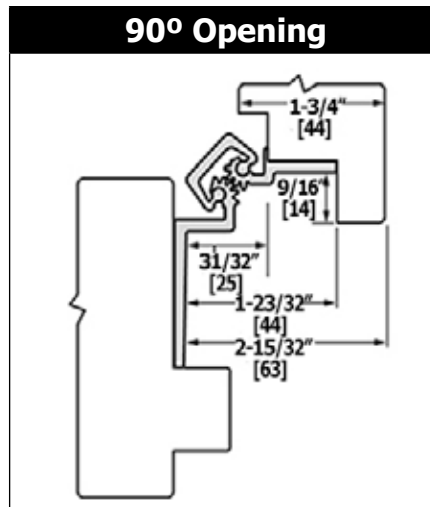
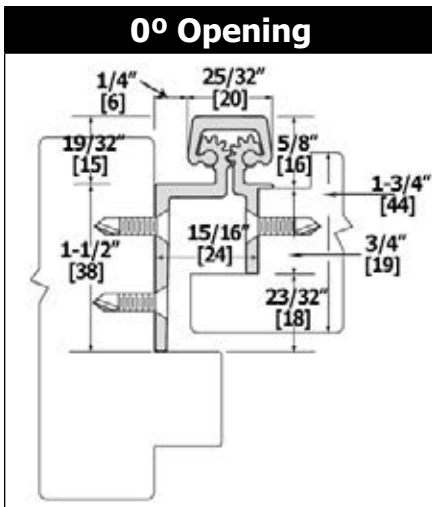



## 780 SERIES CONCEALED LEAF - 780-124HD\*- 780-124LL - HEAVY DUTY OR LEAD LINED

### SPECIFICATIONS

Material:	Aluminum 6063-T6
Clearance:	5/16" (8 mm) hinge side plus standard lockside clearance
Fasteners:	Dril-Kwik® screws
LL Fasteners:	1/2 Dril-Kwik® screws, 1/2 wood screws
Length Options:	Standard and custom lengths available
Door/Frame Reinforcement:	None required to 200 lbs., heavier weight use 16-gauge channel
Optional Fire Rating:	Up to 3-hour metal and 90 minute wood composite (with studs)
Notes:	See additional fire rating details on page 3

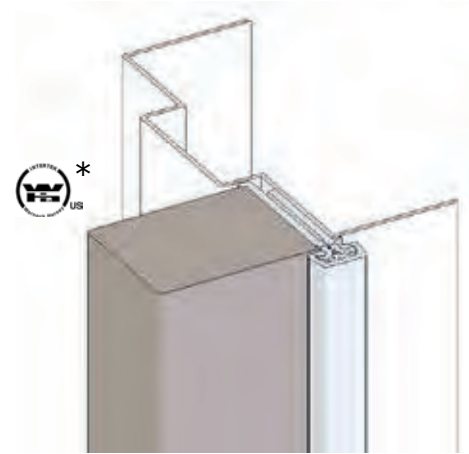

### FEATURES

- Heavy duty for high frequency doors or heavy, medium frequency doors
- Lead lined model for hospital x-ray room doors with double row of screws to straddle lead (Specify "LL")
- Frame alignment rib for proper hinge and door location
- Door edge protection tip

Length		Fastener Count			
Inches	Millimeters	# Per Door		# Per Jamb	
		HD	LL	HD	LL
79	2007	15	32	15	32
83	2108	19	36	19	36
85	2159	19	36	19	36
95	2413	20	42	20	42
119	3023	23	48	23	48

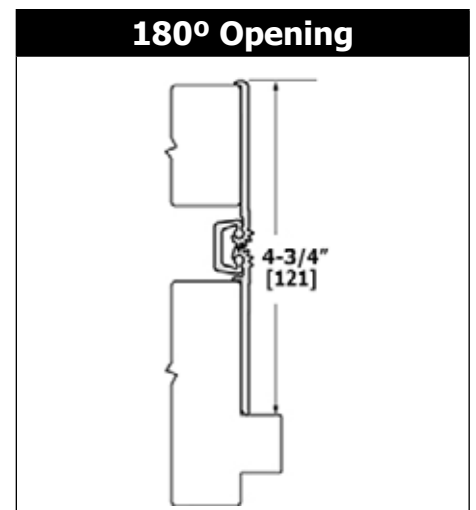
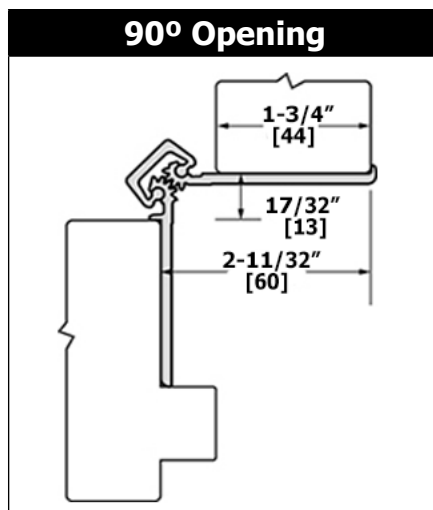
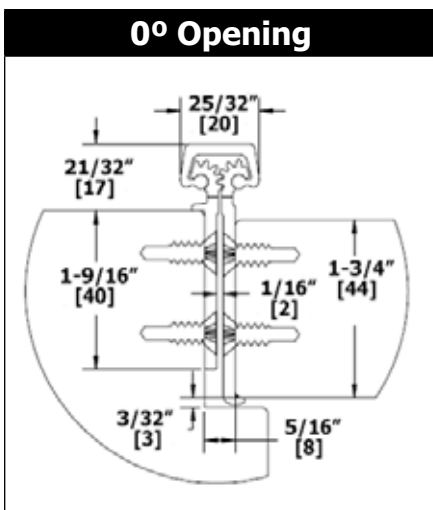

## 780 SERIES CONCEALED LEAF - 780-208HD - HEAVY DUTY

### SPECIFICATIONS

Material:	Aluminum 6063-T6
Clearance:	1/2" (13 mm) hinge side plus standard lockside clearance
Fasteners:	Dril-Kwik® screws
Length Options:	Standard and custom lengths available
Door/Frame Reinforcement:	None required to 200 lbs., heavier weight use 16-gauge channel

### FEATURES

- Standard duty for medium frequency doors. Heavy duty for high frequency doors or heavy, medium frequency doors.
- For millwork, toilet stall doors, windows, and rabbeted bi-fold doors
- Frame and door leaf alignment ribs for proper hinge and door location

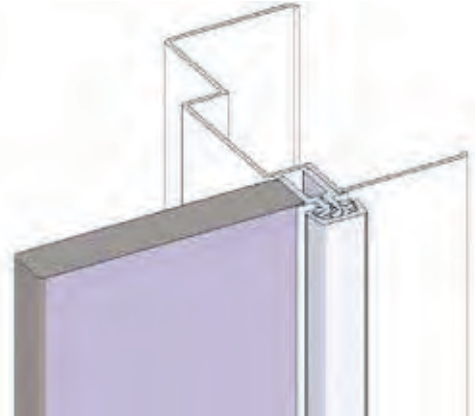

Length		HD Fastener Count	
Inches	Millimeters	# For Door	# For Jamb
79	2007	18	18
83	2108	18	18
85	2159	18	18
95	2413	21	21
119	3023	25	25

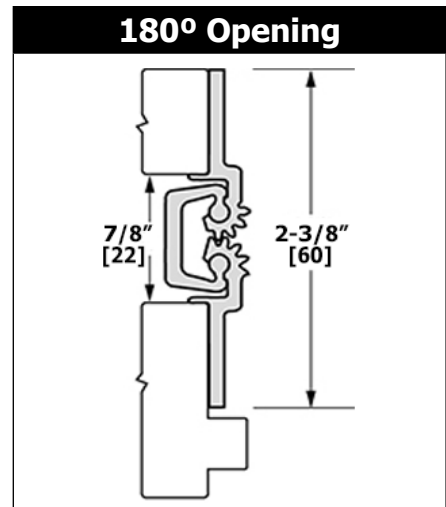
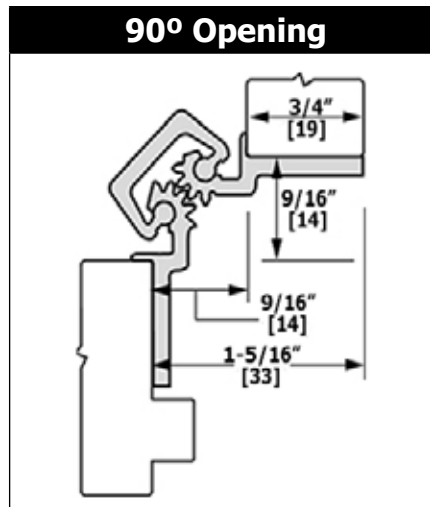
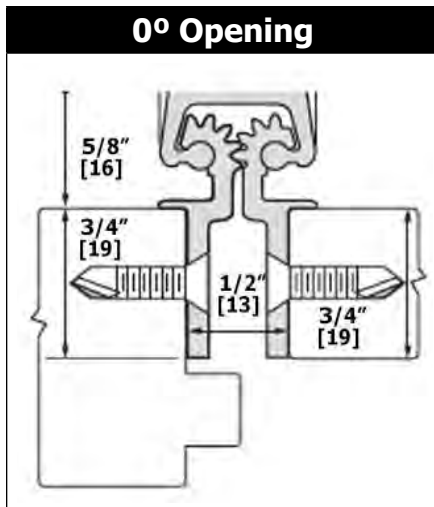



**780 SERIES CONCEALED LEAF - 780-224\* | 780-224HD\* | 780-224LL - STANDARD DUTY, HEAVY DUTY OR LEAD LINED**

**SPECIFICATIONS**

- Material: Aluminum 6063-T6
- Clearance: 5/16" (8 mm) hinge side plus standard lockside clearance
- Fasteners: Dril-Kwik® screws
- LL Fasteners: 1/2 Dril-Kwik® screws, 1/2 wood screws
- Length Options: Standard and custom lengths available
- Door/Frame Reinforcement: None required to 200 lbs., heavier weight use 16-gauge channel
- Optional Fire Rating: Up to 3-hour metal and 90 minute wood composite (with studs)
- Notes: See additional fire rating details on page 3

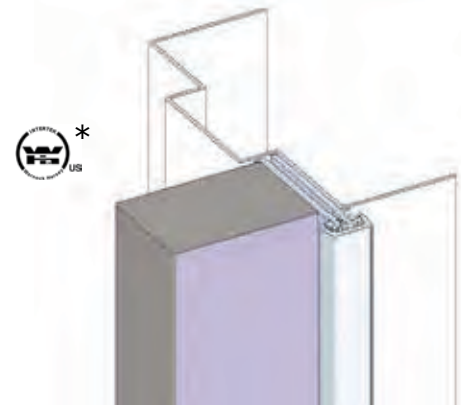

(Left hand shown)

**FEATURES**

- Standard duty for medium frequency doors. Heavy duty for high frequency doors or heavy, medium frequency doors. All for doors 1-3/4" (44 mm) thick.
- Lead lined model for hospital x-ray room doors with double row of screws to straddle lead (Specify "LL")
- Door edge protection lip
- Frame leaf alignment rib for proper hinge and door location
- 3/32" (2 mm) inset hinge and door location

Length		Fastener Count					
Inches	Millimeters	# For Door			# For Jamb		
		SD	HD	LL	SD	HD	LL
79	2007	15	15	32	15	15	32
83	2108	19	19	36	19	19	36
85	2159	19	19	36	19	19	36
95	2413	20	20	42	20	20	42
119	3023	23	23	48	23	23	48

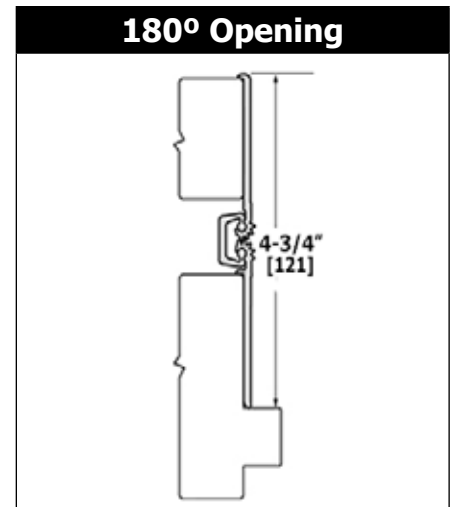
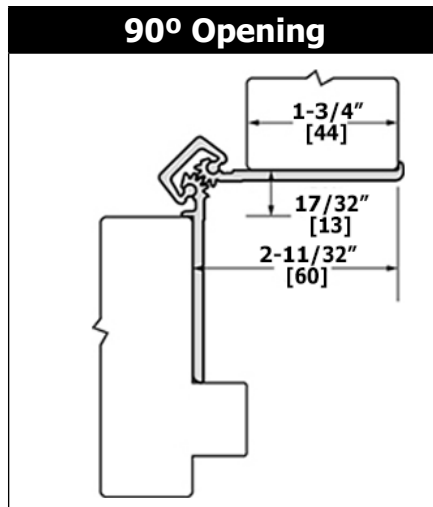
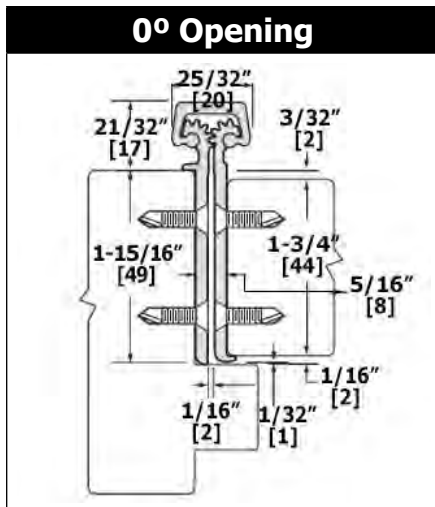

**780 SERIES CONCEALED LEAF - 780-226HD\* | 780-226LL - HEAVY DUTY OR LEAD LINED**

**SPECIFICATIONS**

Material:	Aluminum 6063-T6
Clearance:	5/16" (8 mm) hinge side plus standard lockside clearance
Fasteners:	Dril-Kwik® screws
LL Fasteners:	1/2 Dril-Kwik® screws, 1/2 wood screws
Length Options:	Standard and custom lengths available
Door/Frame Reinforcement:	None required to 200 lbs., heavier weight use 16-gauge channel
Optional Fire Rating:	Up to 3-hour metal and 90 minute wood composite (with studs)
Notes:	See additional fire rating details on page 3

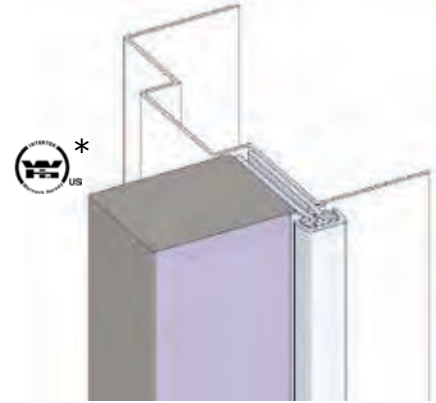

**FEATURES**

- Heavy duty for high frequency doors or heavy, medium frequency doors. All for doors 2" (51 mm) thick or greater.
- Lead lined model for hospital x-ray room doors with double row of screws to straddle lead (Specify "LL")
- Frame and door leaf alignment ribs for proper hinge and door location

Length		Fastener Count			
Inches	Millimeters	# Per Door		#Per Jamb	
		HD	LL	HD	LL
79	2007	15	32	15	32
83	2108	19	36	19	36
85	2159	19	36	19	36
95	2413	20	42	20	42
119	3023	23	48	23	48

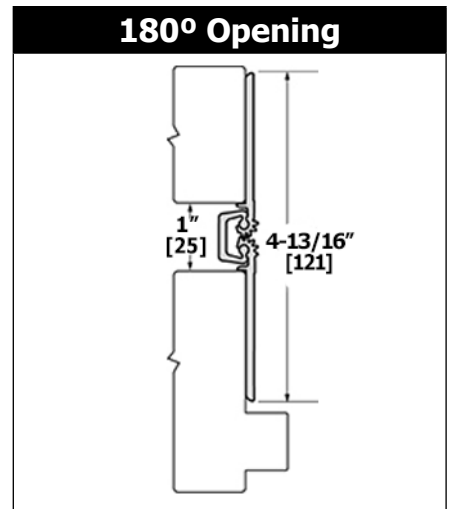
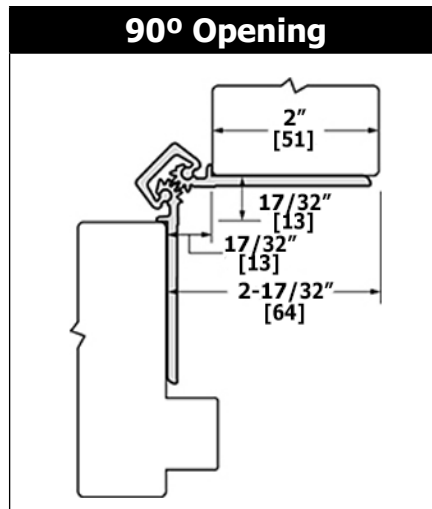
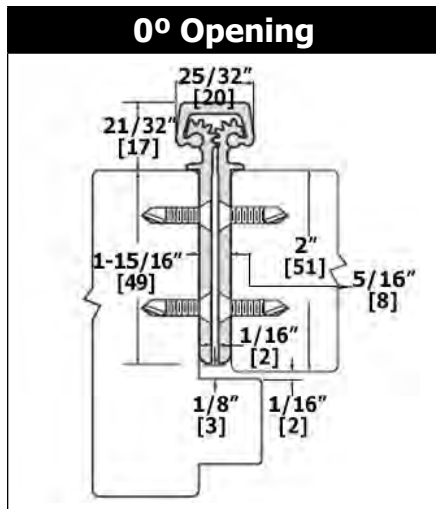



## 780 SERIES CONCEALED LEAF - 780-235HD\* - HEAVY DUTY

### SPECIFICATIONS

Material:	Aluminum 6063-T6
Clearance:	5/16" (8 mm) hinge side plus allow an additional 1/32" to the standard lockside clearance
Fasteners:	Dril-Kwik® screws
Length Options:	Standard and custom lengths available
Door/Frame Reinforcement:	None required to 200 lbs., heavier weight use 16-gauge channel
Optional Fire Rating:	Up to 3-hour metal and 90 minute wood composite (with studs)
Notes:	See additional fire rating details on page 3

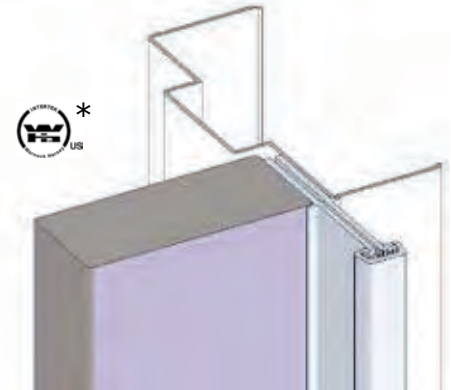

### FEATURES

- Heavy duty for high frequency doors or heavy, medium frequency doors
- Wide Throw for applications that require extra clearance for door or frame
- Frame and door leaf alignment ribs for proper hinge and door location
- For square edged doors on hinge side

Length		HD Fastener Count	
Inches	Millimeters	# For Door	# For Jamb
79	2007	15	15
83	2108	19	19
85	2159	19	19
95	2413	20	20
119	3023	23	23

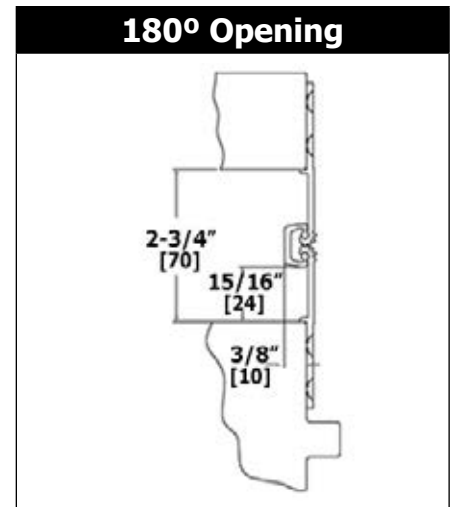
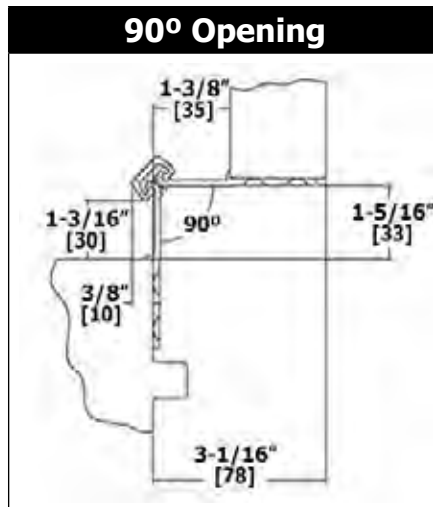
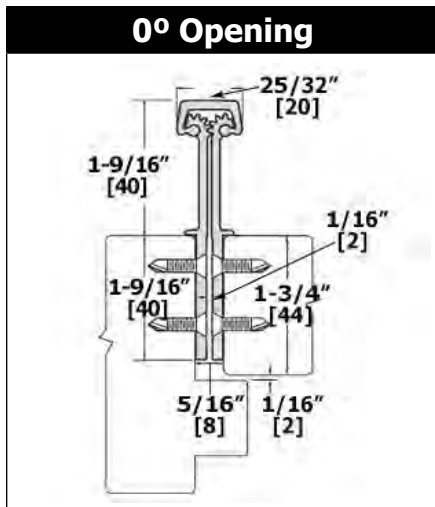

## 780 SERIES FULL SURFACE - 780-057HD - HEAVY DUTY

### SPECIFICATIONS

Material:	Aluminum 6063-T6
Clearance:	1/32" (1 mm) minimum recommended between doors
Fasteners:	Dril-Kwik® screws and sex bolts
Length Options:	Standard and custom lengths available
Door Reinforcement:	None required
Optional Fire Rating:	Up to 3-hour metal and 90 minute wood composite (with studs)
Notes:	See additional fire rating details on page 3

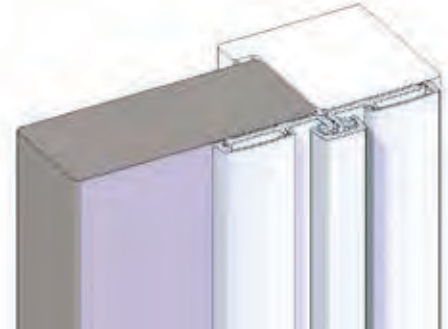

### FEATURES

- Heavy duty for high frequency doors or heavy, medium frequency doors
- Bi-fold applications
- Security moldings

Length		HD Fastener Count	
Inches	Millimeters	# Sex Bolts	# Pan Head
79	2007	16	34
83	2108	16	38
85	2159	16	38
95	2413	18	40
119	3023	20	52

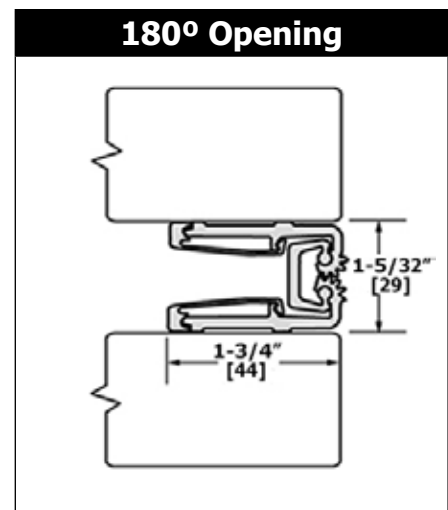
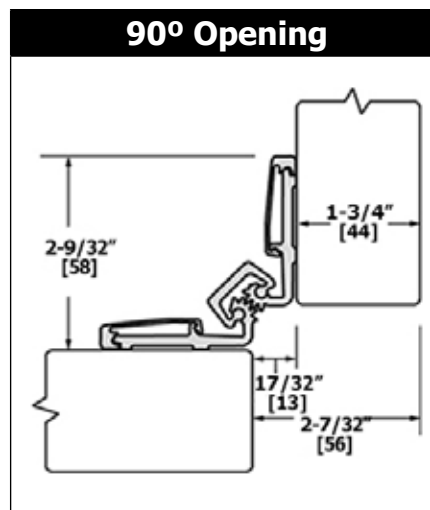
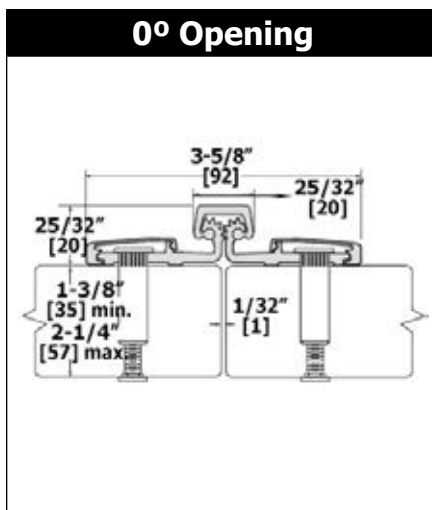





## 780 SERIES FULL SURFACE - 780-157 | 780-157HD - STANDARD DUTY OR HEAVY DUTY

### SPECIFICATIONS

Material:	Aluminum 6063-T6
Clearance:	1/32" (1 mm) minimum recommended for hinge side plus standard lockside clearance
Fasteners:	Dril-Kwik® screws and sex bolts
Length Options:	Standard and custom lengths available
Door Reinforcement:	None required
Frame Reinforcement:	None required to 200 lbs., heavier weight use 16-gauge channel
Optional Fire Rating:	Up to 3-hour metal and 90 minute wood composite (with studs)
Notes:	See additional fire rating details on page 3

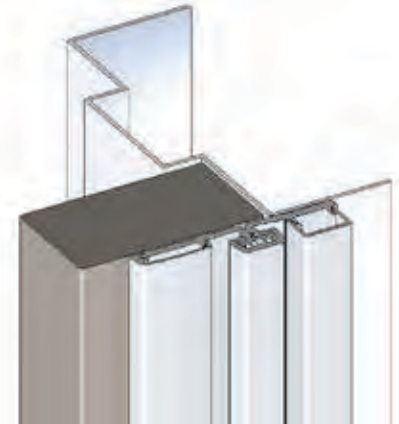

(Left hand shown)

### FEATURES

- Standard duty for medium frequency doors.  
Heavy duty for high frequency doors or heavy, medium frequency doors.
- For surface applications where frame face dimension is limited
- Security moldings
- 1/16" (1.5 mm) inset

Length		Fastener Count			
		# Sex Bolts		# Pan Head	
Inches	Millimeters	SD	HD	SD	HD
79	2007	8	8	34	34
83	2108	8	8	38	38
85	2159	8	8	38	38
95	2413	9	9	41	41
119	3023	10	10	52	52

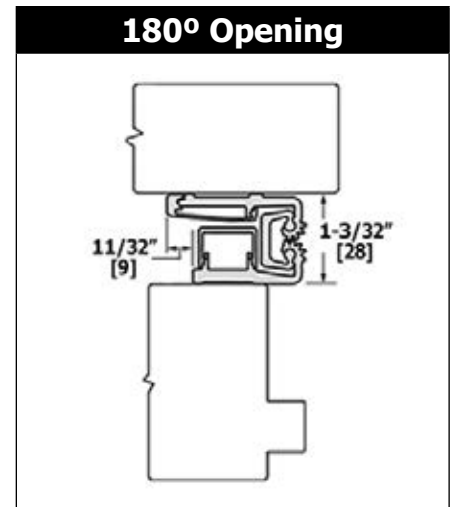
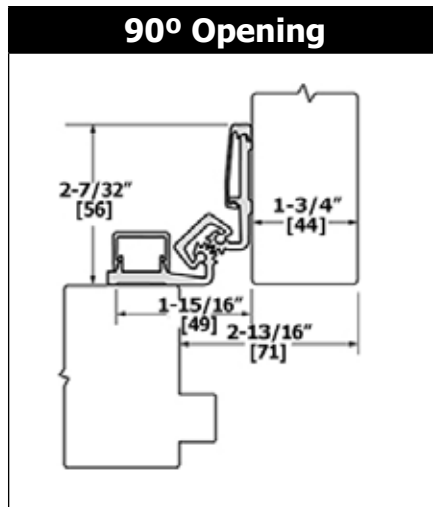
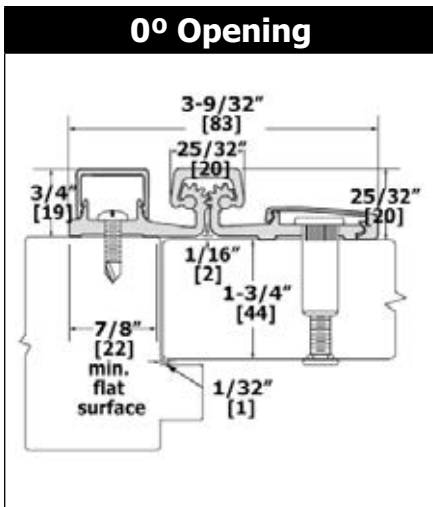

## 780 SERIES FULL SURFACE - 780-210 | 780-210HD - STANDARD DUTY OR HEAVY DUTY

### SPECIFICATIONS

Material:	Aluminum 6063-T6
Clearance:	1/32" (1 mm) minimum recommended for hinge side plus standard lockside clearance. 1-5/8" (41 mm) minimum frame face required plus 3/16" (5 mm) rotational clearance
Fasteners:	Dril-Kwik® screws and sex bolts
Length Options:	Standard and custom lengths available
Door Reinforcement:	None required
Frame Reinforcement:	None required to 200 lbs., heavier weight use 16-gauge channel
Optional Fire Rating:	Up to 3-hour metal and 90 minute wood composite (with studs)
Notes:	See additional fire rating details on page 3



(Left hand shown)

### FEATURES

- Standard duty for medium frequency doors. Heavy duty for high frequency doors or heavy, medium frequency doors.
- Can be used with any door and frame material
- Security molding
- 1/32" (1 mm) inset

Length		Fastener Count					
		# Sex Bolts		# Pan Head		# For Jamb	
Inches	Millimeters	SD	HD	SD	HD	SD	HD
79	2007	8	8	17	17	17	17
83	2108	10	10	17	17	19	19
85	2159	10	10	17	17	19	19
95	2413	11	11	18	18	21	21
119	3023	12	12	24	24	26	26

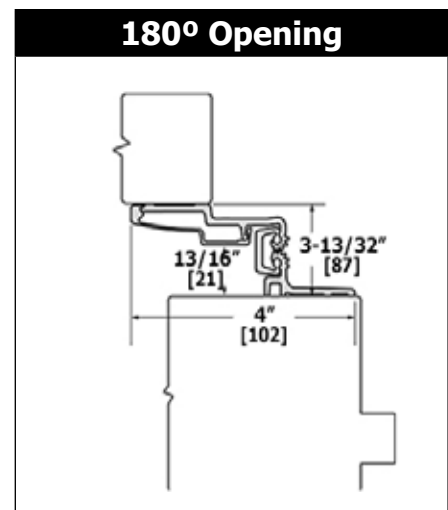
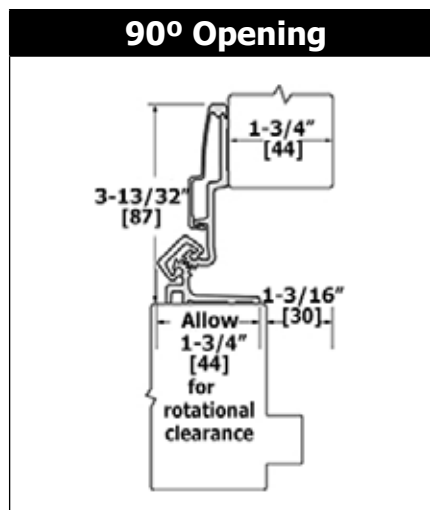
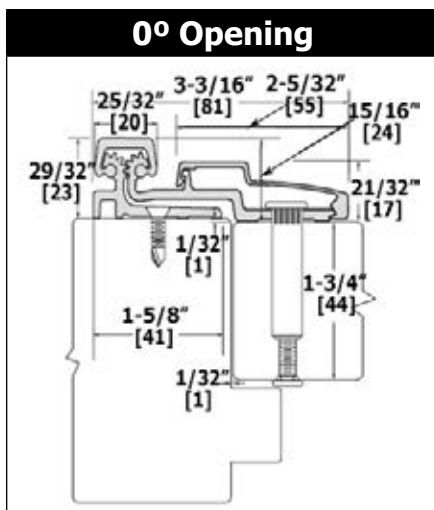



## 780 SERIES FULL SURFACE - 780-257HD - HEAVY DUTY

### SPECIFICATIONS

Material:	Aluminum 6063-T6
Clearance:	1/32" (1 mm) minimum recommended between mullion and door plus standard lockside clearance - 7/8" (22 mm) to 2-1/4" (57 mm) mullion width
Fasteners:	Dril-Kwik® screws and sex bolts
Length Options:	Standard and custom lengths available
Door Reinforcement:	None required
Frame Reinforcement:	None required to 200 lbs., heavier weight use 16-gauge channel
Optional Fire Rating:	Up to 3-hour metal and 90 minute wood composite (with studs)
Notes:	See additional fire rating details on page 3

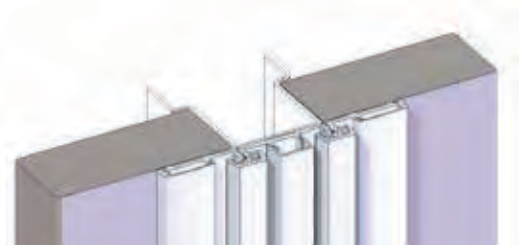

### FEATURES

- Heavy duty for high frequency doors or heavy, medium frequency doors
- Double hinge for hanging two entrance doors from a fixed mullion
- Security moldings
- 1/16" (1.5 mm) inset

Length		HD Fastener Count		
Inches	Millimeters	# Sex Bolts	# Pan Head	# For Jamb
79	2007	16	34	17
83	2108	16	38	19
85	2159	16	38	19
95	2413	18	40	21
119	3023	20	52	26

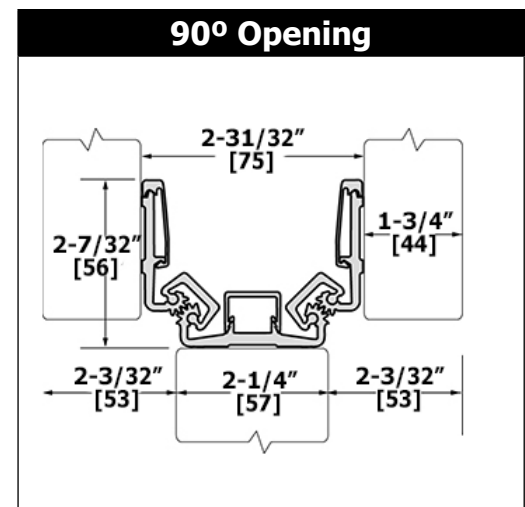
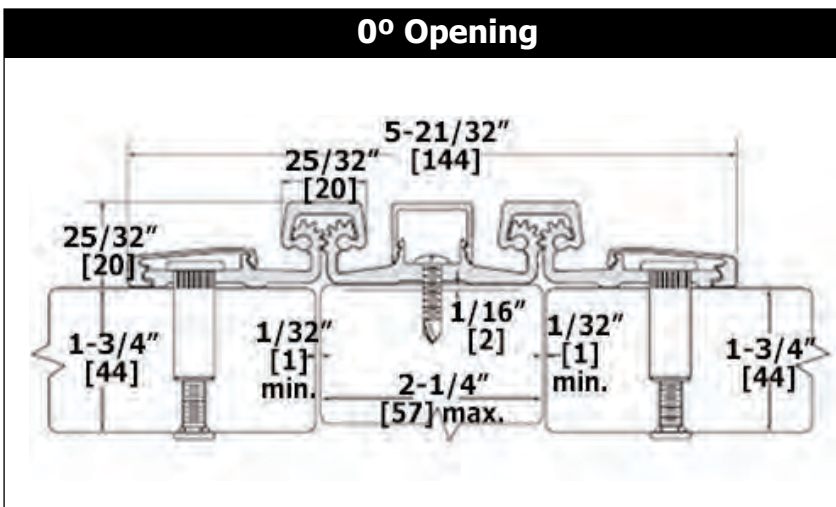

## 780 SERIES HALF SURFACE - 780-045HD - HEAVY DUTY

### SPECIFICATIONS

Material:	Aluminum 6063-T6
Clearance:	5/32" (4 mm) minimum recommended hinge side plus standard lockside clearance
Fasteners:	Dril-Kwik® screws and sex bolts
Length Options:	Standard and custom lengths available
Door Reinforcement:	None required
Frame Reinforcement:	None required to 200 lbs., heavier weight use 16-gauge channel
Optional Fire Rating:	Up to 3-hour metal and 90 minute wood composite (with studs)
Notes:	See additional fire rating details on page 3

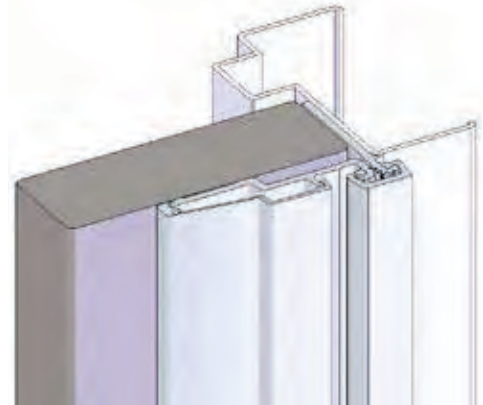

(Left hand shown)

### FEATURES

- Heavy duty for high frequency doors or heavy, medium frequency doors
- Frame leaf alignment rib for proper hinge location
- Security molding
- 9/32" (7 mm) inset

Length		HD Fastener Count		
Inches	Millimeters	# Sex Bolts	# Pan Head	# For Jamb
79	2007	8	17	15
83	2108	8	19	19
85	2159	8	19	19
95	2413	9	20	20
119	3023	10	26	35

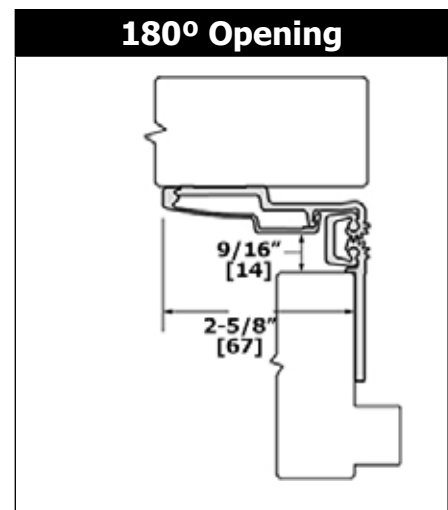
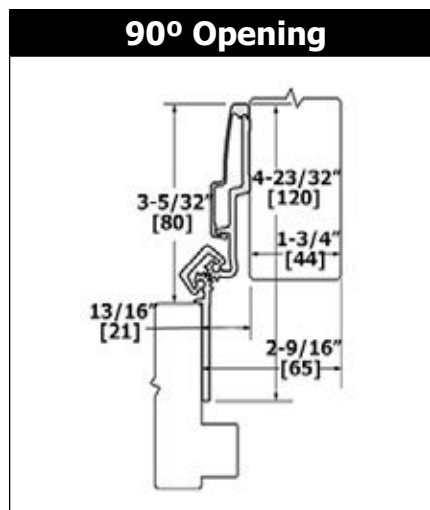
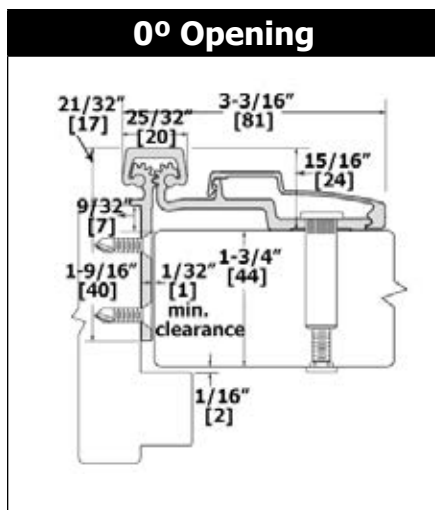



## 780 SERIES HALF SURFACE - 780-046HD - HEAVY DUTY

### SPECIFICATIONS

Material:	Aluminum 6063-T6
Clearance:	5/32" (4 mm) minimum recommended hinge side plus standard lockside clearance
Fasteners:	Dril-Kwik® screws and sex bolts
Length Options:	Standard and custom lengths available
Door Reinforcement:	None required
Frame Reinforcement:	None required to 200 lbs., heavier weight use 16-gauge channel
Optional Fire Rating:	Up to 3-hour metal and 90 minute wood composite (with studs)
Notes:	See additional fire rating details on page 3

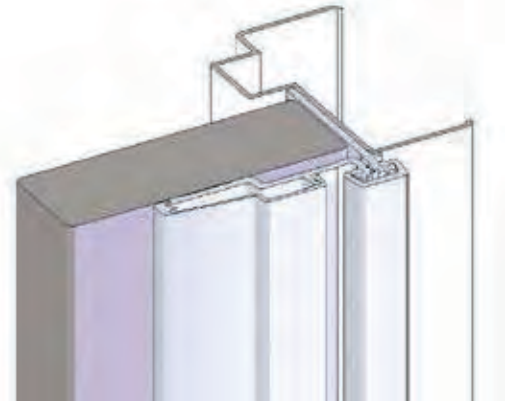

(Left hand shown)

### FEATURES

- Heavy duty for high frequency doors or heavy, medium frequency doors
- Complete frame rabbet coverage for 1-3/4" (45 mm) frames, with 1-3/8" (35 mm) doors
- Frame leaf alignment rib for proper hinge location
- Security molding
- 9/32" (7 mm) inset

Length		HD Fastener Count		
Inches	Millimeters	# Sex Bolts	# Pan Head	# For Jamb
79	2007	8	17	15
83	2108	8	19	19
85	2159	8	19	19
95	2413	9	20	20
119	3023	10	26	23

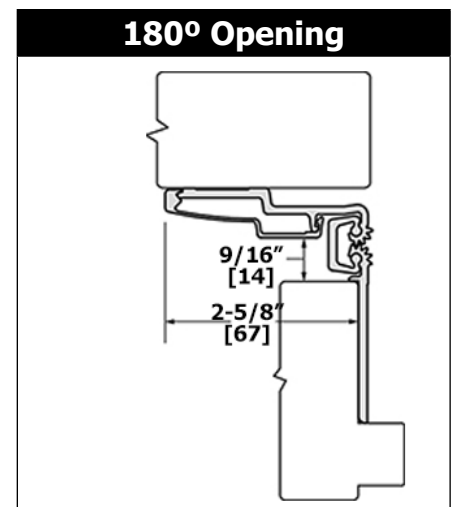
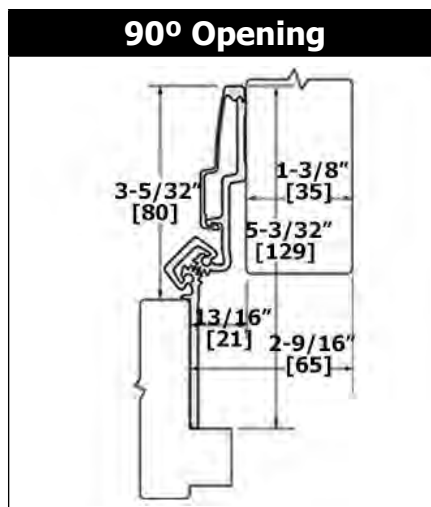
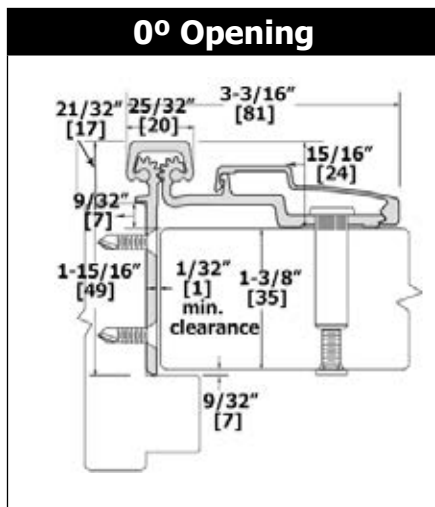

## 780 SERIES HALF SURFACE - 780-053 | 780-053HD - STANDARD DUTY OR HEAVY DUTY

### SPECIFICATIONS

Material:	Aluminum 6063-T6
Clearance:	5/32" (4 mm) minimum recommended hinge side plus standard lockside clearance
Fasteners:	Dril-Kwik® screws and sex bolts
Length Options:	Standard and custom lengths available
Door Reinforcement:	None required
Frame Reinforcement:	None required to 200 lbs., heavier weight use 16-gauge channel
Optional Fire Rating:	Up to 3-hour metal and 90 minute wood composite; (with studs)
Notes:	See additional fire rating details on page 3

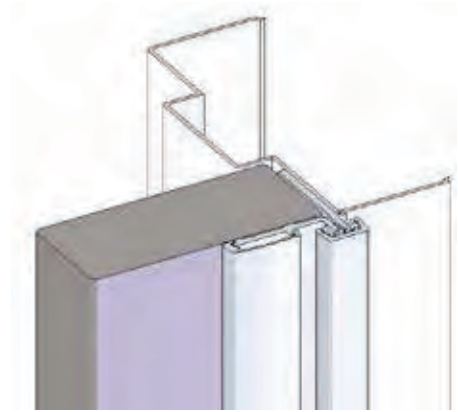

(Left hand shown)

### FEATURES

- Standard duty for medium frequency doors. Heavy duty for high frequency doors or heavy, medium frequency doors
- Frame leaf alignment rib for proper hinge location
- Security molding
- 1/8" (3 mm) inset

Length		Fastener Count					
Inches	Millimeters	# Sex Bolts		# Pan Head		# For Jamb	
		SD	HD	SD	HD	SD	HD
79	2007	6	6	11	11	15	15
83	2108	6	6	13	13	19	19
85	2159	6	6	13	13	19	19
95	2413	7	7	12	12	20	20
119	3023	8	8	15	15	23	23

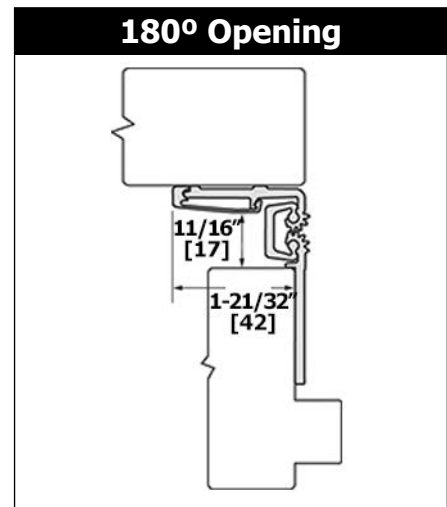
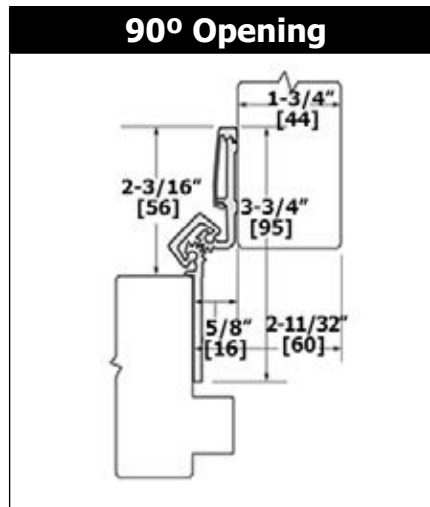
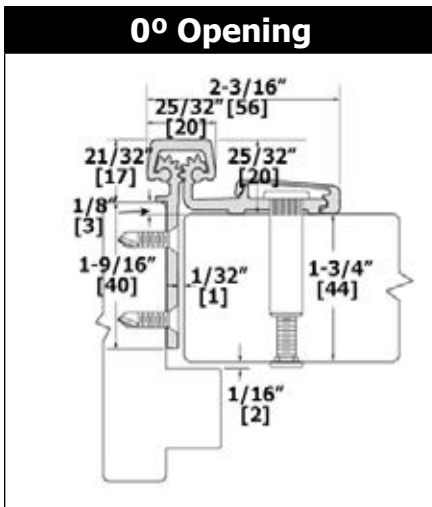



## 780 SERIES HALF SURFACE - 780-054HD - HEAVY DUTY

### SPECIFICATIONS

Material:	Aluminum 6063-T6
Clearance:	5/32" (4 mm) minimum recommended hinge side plus standard lockside clearance
Fasteners:	Dril-Kwik® screws and sex bolts
Length Options:	Standard and custom lengths available
Door Reinforcement:	None required
Frame Reinforcement:	None required to 200 lbs., heavier weight use 16-gauge channel
Optional Fire Rating:	Up to 3-hour metal and 90 minute wood composite (with studs)
Notes:	See additional fire rating details on page 3

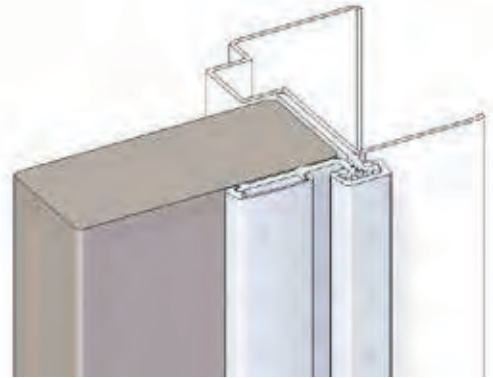

(Left hand shown)

### FEATURES

- Heavy duty for high frequency doors or heavy, medium frequency doors
- Frame leaf alignment rib for proper hinge location
- Security molding
- 1/8" (3 mm) inset

Length		HD Fastener Count		
Inches	Millimeters	# Sex Bolts	# Pan Head	# For Jamb
79	2007	8	17	15
83	2108	8	19	19
85	2159	8	19	19
95	2413	9	20	20
119	3023	10	26	23

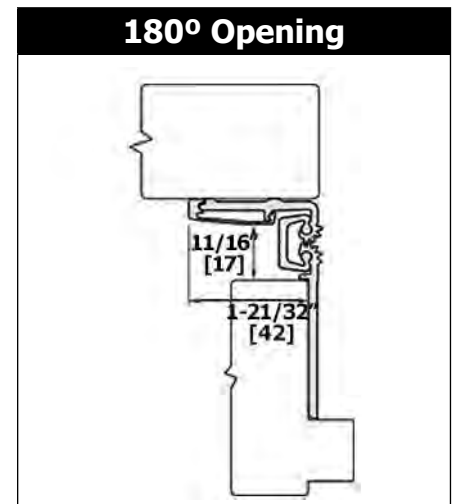
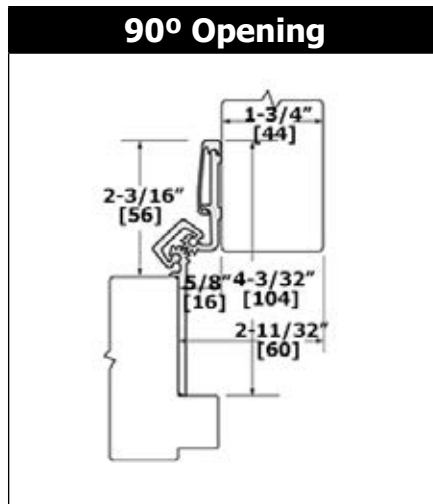
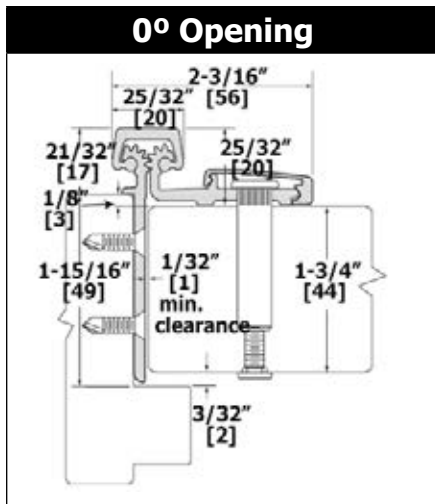

## 780 SERIES HALF SURFACE - 780-155HD - HEAVY DUTY

### SPECIFICATIONS

Material:	Aluminum 6063-T6
Clearance:	5/32" (4 mm) minimum recommended hinge side plus standard lockside clearance
Fasteners:	Dril-Kwik® screws and sex bolts
Length Options:	Standard and custom lengths available
Door Reinforcement:	None required
Frame Reinforcement:	None required to 200 lbs., heavier weight use 16-gauge channel

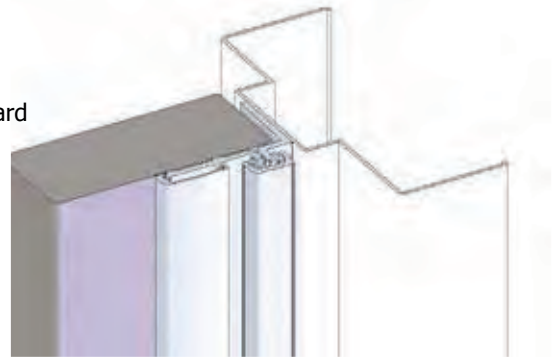

(Left hand shown)

### FEATURES

- Heavy duty for high frequency doors or heavy, medium frequency doors
- For center hung and double egress conversions
- Security molding

Length		HD Fastener Count		
Inches	Millimeters	# Sex Bolts	# Pan Head	# For Jamb
79	2007	8	17	23
83	2108	8	19	23
85	2159	8	19	23
95	2413	9	20	26
119	3023	10	26	30

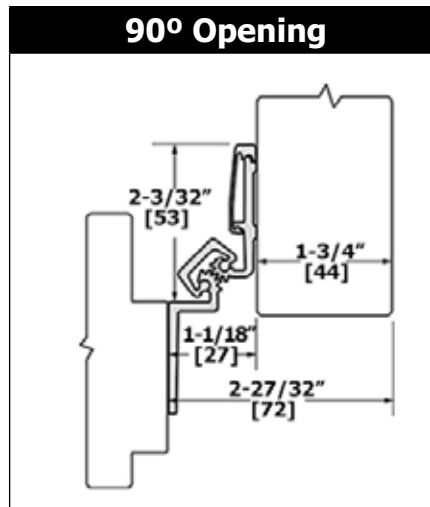
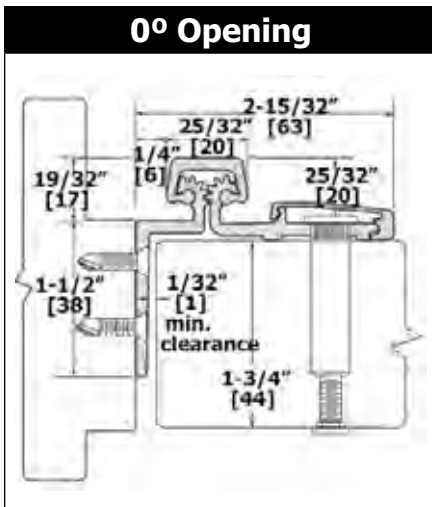





## 780 SERIES HALF SURFACE - 780-211HD - HEAVY DUTY

### SPECIFICATIONS

Material:	Aluminum 6063-T6
Clearance:	5/32" (4 mm) minimum recommended hinge side plus standard lockside clearance
Fasteners:	Dril-Kwik® screws and sex bolts
Length Options:	Standard and custom lengths available
Door Reinforcement:	None required
Frame Reinforcement:	None required to 200 lbs., heavier weight use 16-gauge channel
Fire Rating:	Up to 3-hour metal and 90 minute wood composite (with studs)

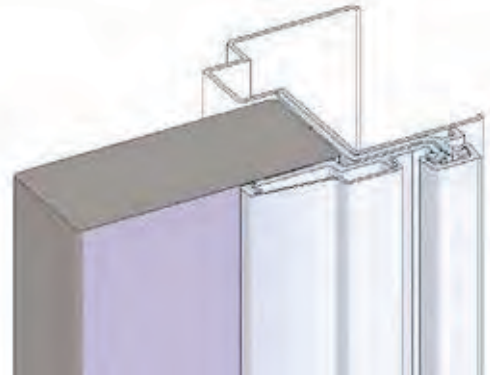

(Left hand shown)

### FEATURES

- Heavy duty for high frequency doors or heavy, medium frequency doors
- Frame leaf wrap-around reinforcement for damaged frames
- Security molding
- 1/16" (1.5 mm) inset

Length		HD Fastener Count		
Inches	Millimeters	# Sex Bolts	# Pan Head	# For Jamb
79	2007	8	17	15
83	2108	8	19	19
85	2159	8	19	19
95	2413	9	20	19
119	3023	10	26	21

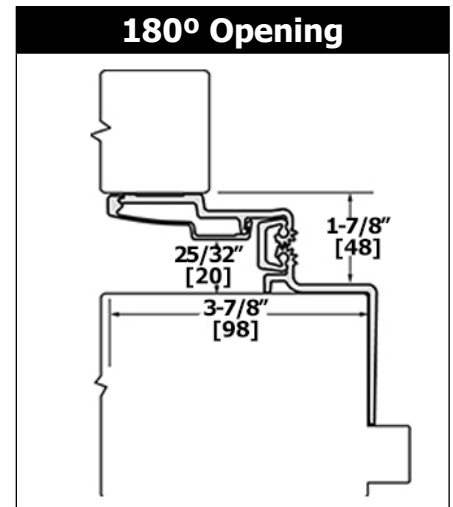
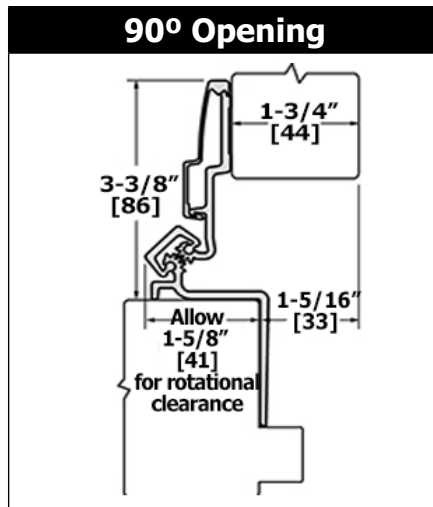
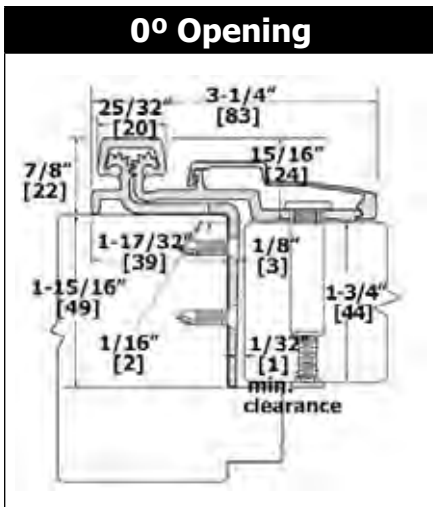

## 780 SERIES HALF SURFACE - 780-213HD - HEAVY DUTY

### SPECIFICATIONS

Material:	Aluminum 6063-T6
Clearance:	5/32" (4 mm) minimum recommended hinge side plus standard lockside clearance
Fasteners:	Dril-Kwik® screws and sex bolts
Length Options:	Standard and custom lengths available
Door Reinforcement:	None required
Frame Reinforcement:	None required to 200 lbs., heavier weight use 16-gauge channel

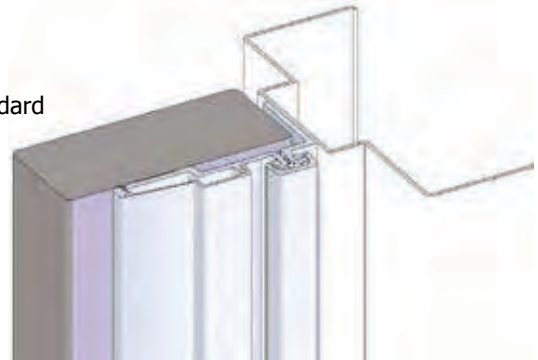

(Left hand shown)

### FEATURES

- Heavy duty for high frequency doors or heavy, medium frequency doors
- For center hung door where large edge radii or finger guards require a long reach
- Security molding

Length		HD Fastener Count		
Inches	Millimeters	# Sex Bolts	# Pan Head	# For Jamb
79	2007	6	11	15
83	2108	6	13	15
85	2159	6	13	15
95	2413	7	12	17
119	3023	8	15	19

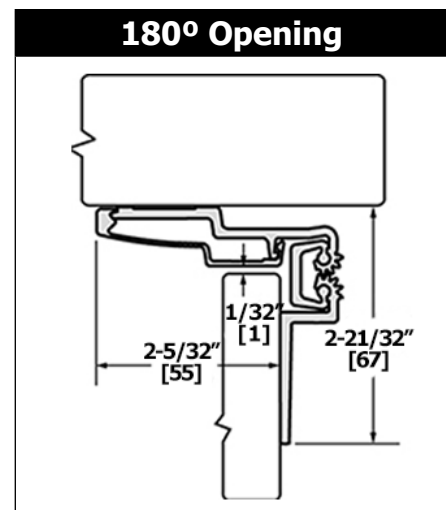
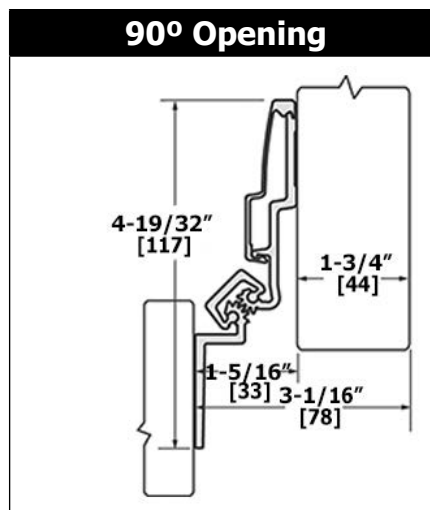
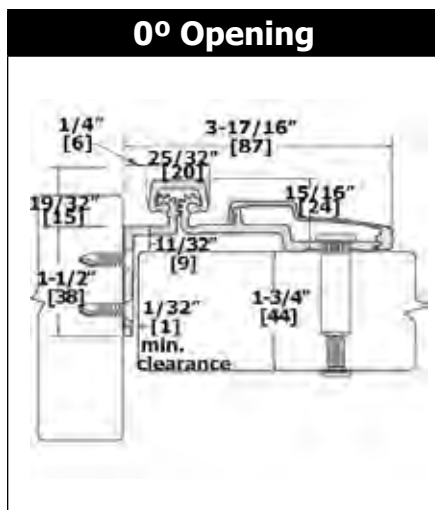



## 780 SERIES HALF SURFACE - 780-259HD - HEAVY DUTY

### SPECIFICATIONS

Material:	Aluminum 6063-T6
Clearance:	5/32" (4 mm) minimum recommended hinge side plus standard lockside clearance
Fasteners:	Dril-Kwik® screws and sex bolts
Length Options:	Standard and custom lengths available
Door Reinforcement:	None required
Frame Reinforcement:	None required to 200 lbs., heavier weight use 16-gauge channel

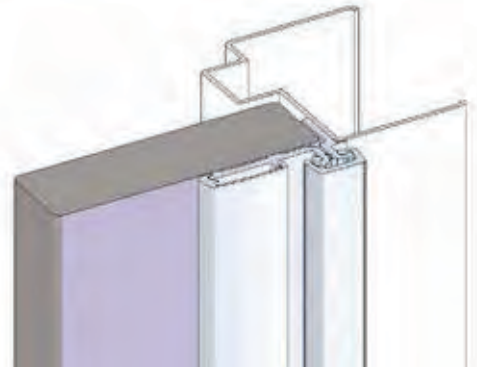

(Left hand shown)

### FEATURES

- Heavy duty for high frequency doors or heavy, medium frequency doors
- Frame leaf alignment rib for proper hinge location
- For custom applications with thinner doors
- Security molding
- 1/8" (3 mm) inset

Length		HD Fastener Count		
Inches	Millimeters	# Sex Bolts	# Pan Head	# For Jamb
79	2007	8	17	18
83	2108	8	19	18
85	2159	8	19	18
95	2413	9	20	21
119	3023	10	26	25

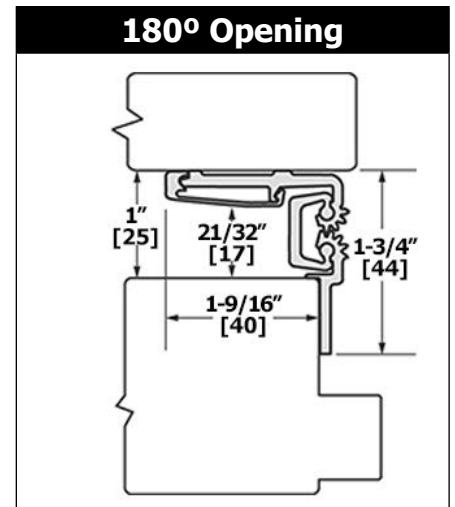
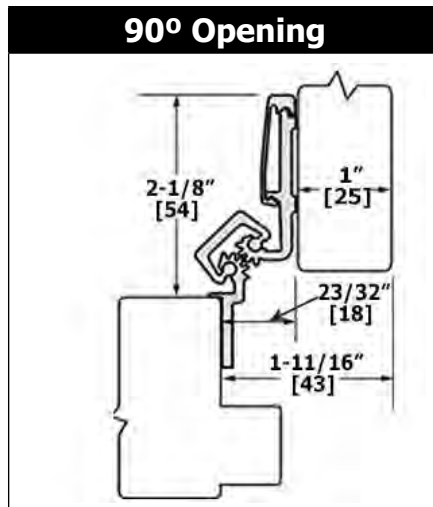
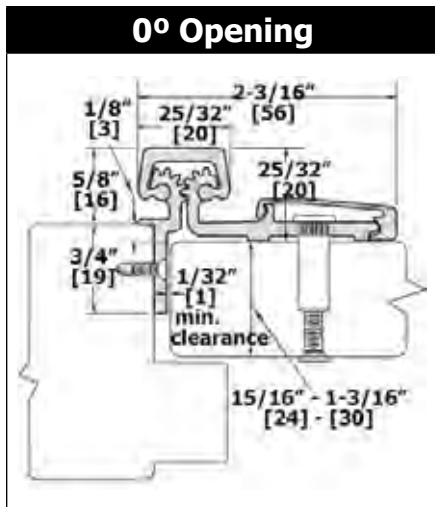

## 780 SERIES HALF SURFACE - 780-300HD - HEAVY DUTY

### SPECIFICATIONS

Material:	Aluminum 6063-T6
Clearance:	1/32" (1 mm) minimum recommended between door and frame
Fasteners:	Dril-Kwik® screws
Length Options:	Standard and custom lengths available
Door/Frame Reinforcement:	None required to 200 lbs., heavier weight use 16-gauge channel

### FEATURES

- Heavy duty for high frequency, center hung doors or heavy, medium frequency, center hung doors
- For center hung door application
- 3/4" (19 mm) minimum inset

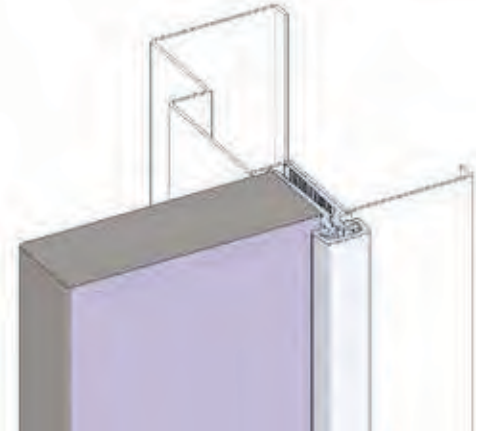

(Left hand shown)

Length		HD Fastener Count	
Inches	Millimeters	# For Door	# For Jamb
79	2007	14	14
83	2108	14	14
85	2159	14	14
95	2413	16	16
119	3023	20	20

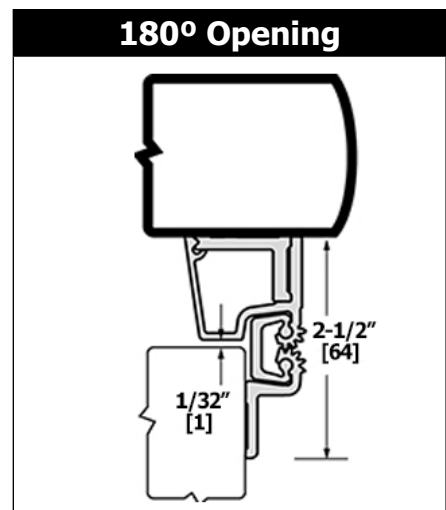
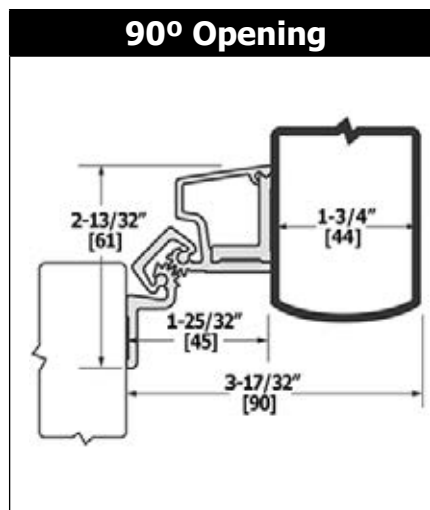
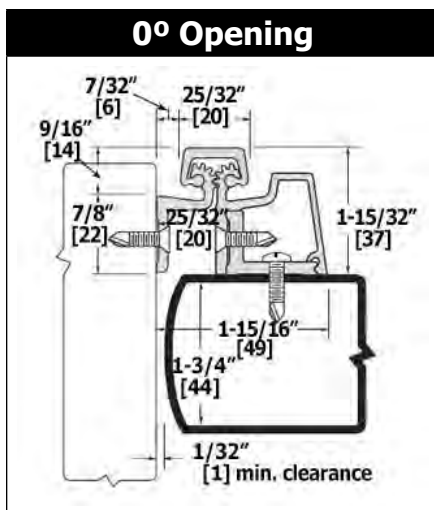



## 1200 SERIES EXTRA HEAVY DUTY - 1200-600XHD - CONCEALED LEAF HINGE

### SPECIFICATIONS

Material:	Aluminum 6063-T6
Clearance:	15/32" (12 mm) hinge side plus standard lockside clearance
Fasteners:	1/4"-20 Dril-Kwik® screws or optional 1/4-14 x 1-1/2" wood screws
Length Options:	Standard and custom lengths available
Door/Frame Reinforcement:	For doors up to 200 lbs. Use 1/8" reinforcement for doors greater than 200 lbs.

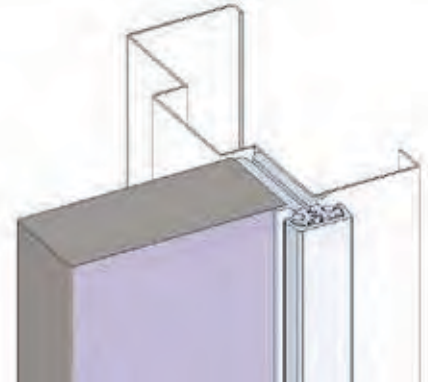

### FEATURES

- Strong enough to swing doors heavier than 600 lbs., wider than 4 feet, and taller than 10 feet. Extra heavy duty for heavy, high frequency doors or extremely heavy, low frequency doors; for doors 1-3/4" (45 mm) to 2-3/8" (60 mm) thick.
- Lead lined model for hospital x-ray room doors with double row of screws to straddle lead (Specify "LL")
- Frame and door leaf alignment ribs for proper hinges and door location

Length		XHD Fastener Count	
Inches	Millimeters	# Per Door	# Per Jamb
79	2007	22	22
83	2108	26	26
85	2159	26	26
95	2413	28	28
119	3023	33	33

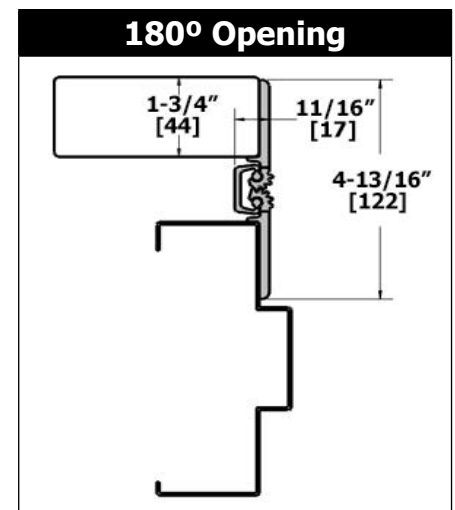
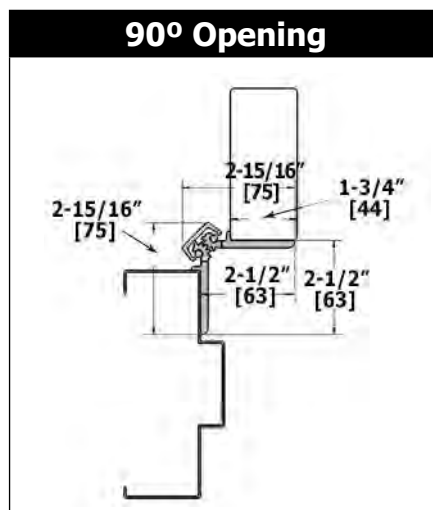
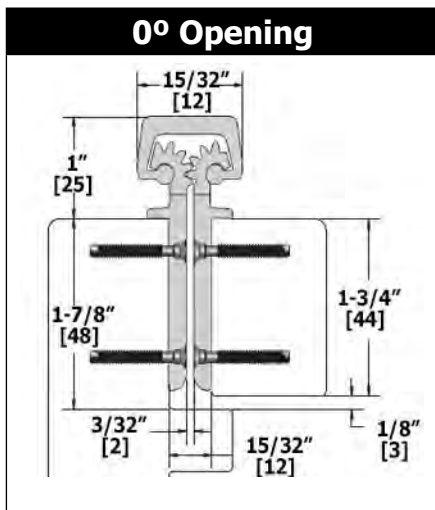

## 1200 SERIES EXTRA HEAVY DUTY - 1200-650XHD - CONCEALED LEAF HINGE

### SPECIFICATIONS

Material:	Aluminum 6063-T6
Clearance:	15/32" (12 mm) hinge side plus standard lockside clearance
Fasteners:	1/4"-20 Dril-Kwik® screws or optional 1/4-14 x 1-1/2" wood screws
Length Options:	Standard and custom lengths available
Door/Frame Reinforcement:	For doors up to 200 lbs. Use 1/8" reinforcement for doors greater than 200 lbs.

### FEATURES

- Strong enough to swing doors heavier than 600 lbs., wider than 4 feet, and taller than 10 feet. Extra heavy duty for heavy, high frequency doors or extremely heavy, low frequency doors; for doors thicker than 2-3/8" (60 mm).
- Lead lined model for hospital x-ray room doors with double row of screws to straddle lead (Specify "LL")
- Frame and door leaf alignment ribs for proper hinges and door location

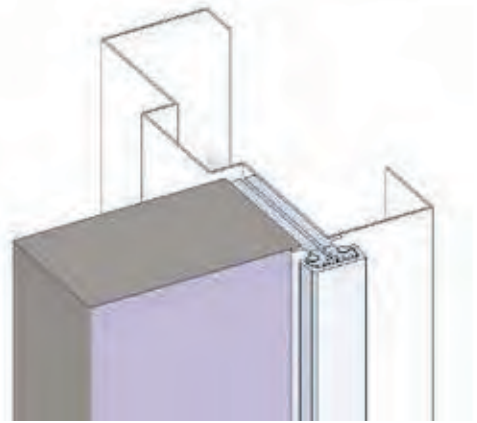

Length		XHD Fastener Count	
Inches	Millimeters	# Per Door	# Per Jamb
79	2007	22	22
83	2108	26	26
85	2159	26	26
95	2413	28	28
119	3023	33	33

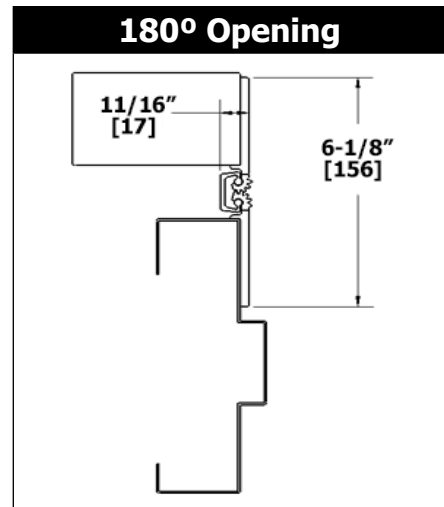
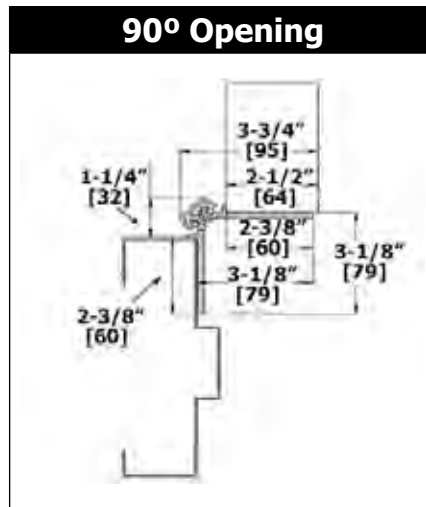
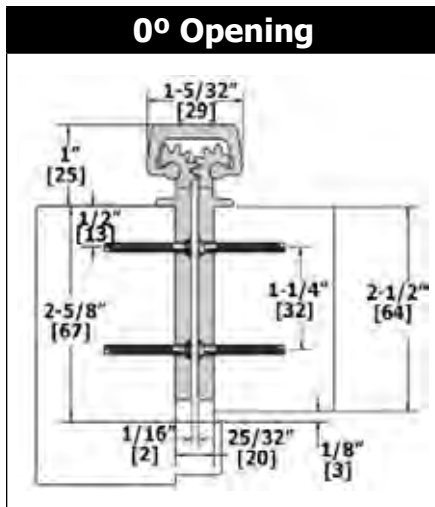



**One Family. One Brand. One Vision.™**

[www.hagerco.com](http://www.hagerco.com)

# Stainless Steel Continuous Hinges



**Why Continuous?** Hager Companies heavy duty stainless steel continuous hinges are designed and engineered to evenly distribute door weight along the full length of the door, which eliminates localized stresses on the frame and reduces hinge failure. Hinges also help eliminate stress on closers, automatic operators, and panic and locking hardware by helping doors to stay properly aligned and offer proven reliability that can stand up to the daily rigors of high-traffic, high-impact areas.

## Table of Contents

Benefits and Features .....	2
Product Information .....	3
Fasteners .....	5
General Information .....	6
Electric Modifications .....	8
Concealed Leaf .....	10
Half Surface .....	15
Half Mortise .....	16
Full Surface .....	18





## BENEFITS AND FEATURES

### Heavy Duty, High-Quality Construction

Hager Companies stainless steel continuous hinges are 14-gauge type 304 stainless steel with lubricated nylon 6/6 bearings between each knuckle and stainless steel pin. They are corrosion resistant for swimming pool buildings, sewage and water treatment plants, and salt spray environments. These hinges are ideal for hospitals and other institutions where doors and frames are subjected to severe abuse.

### Superior Performance

Hager Companies stainless steel continuous hinges allow doors to stay properly aligned, eliminating stress on closers, automatic operators, panic, and locking hardware.

### Ease of Installation

Each hinge has symmetrical, non-handed hole patterns on standard sizes.

### Ideal for Retrofit

Hager Companies 790 Series stainless steel continuous hinges use the existing frame and cover the old butt hinge cut out locations.

### Energy Savings

These stainless steel continuous hinges provide a permanent weather barrier and reduce air infiltration by creating a seal from top to bottom of the door at the hinge stile.

### Fire-Rated

Hager Companies 790 Series stainless steel continuous hinges are stamped with an Underwriters Laboratories Inc. fire label. Refer to the individual catalog pages for UL listing information.



### Security

Hager Companies 790 Series stainless steel continuous hinges eliminate the gap between the door and frame, so doors cannot be pried open.

### Privacy

Hager Companies 790 Series stainless steel continuous hinges eliminate the gap or sightline at the hinge edge, offering privacy on hospital or toilet partition applications.

### Certification

Hager Companies 790 Series stainless steel continuous hinges are approved for ANSI A156.26 Grade 1 for 150-pound doors.

### Added Features

Moldings are supplied to cover exposed fastener heads on half-surface and full-surface models and are screwed in place. Models with hinge guards are supplied with adjustable screws allowing up to 1/4" (9 mm) width adjustment for doors to be squared accurately and easily in new installations and retrofits.

### Wide Throw

The width of the hinge leaf can be extended in order to clear the trim or wall conditions.



## PRODUCT INFORMATION

### DOOR AND FRAME PREPARATION

All 790 Series stainless steel continuous hinges are surface applied without cutouts. Cutout design and spacing coordination is thereby eliminated in both new construction and restoration work.

For models other than double edge guard models, reinforcement plates are not required in doors and frames except where the gauge is too thin or the material is too weak for the fasteners in relation to the door weight, or where abusive operation is anticipated. Consult Hager Companies Technical Service for more information.

Blank frames may be ordered with strike prep only or with a strike prep furnished on both sides with any model that will cover the frame rabbet. Doors should always be ordered without cutouts except for use in labeled openings in which the tested door assembly may have manufacturing restrictions. Continuous frame mortar guards are strongly recommended for masonry walls to avoid screw fastener interference with the mortar.

### Standard Finish

All 790 Series stainless steel continuous hinges are brushed to a satin finish (US32D).

### Special Finishes

Available in powder coat and offered in our stock colors listed in the price book.

### Recommended Lengths

All 790 Series stainless steel continuous hinges are always installed flush with the top edge of the door. Recommended head clearance is 1/8" (3 mm). Order each hinge equal to the net door height. In the field, trimming should be done from the bottom of the hinge only.

### Custom Length Hinges

Hager Companies manufactures hinges over 119" (2023 mm) as two separate lengths. Hager will select hinge segment lengths from standard sizes for best economics in relation to length required. A special length should be specified from the net door height. To order, list the required hinge length dimension along with the "actual length" or "net door height."

### Custom Designs

For special designs and special applications, contact Hager Customer Service for more information. While such orders become subject to the change and cancellation policy, hole positioning will be optimized to ensure that the appearance and operation of the products are maintained.

### Custom Hole Pattern

Any hole pattern or shape other than Hager's standard hole pattern are available on all models. Contact Hager Customer Service for more information.

### No-Hole (Blank) Hinges

Holes omitted for special applications (i.e. welded hinge) is available on all models. Contact Hager Customer Service for more information.

## PRODUCT INFORMATION

### **Door Edge Guards**

Various models are supplied with a 14-gauge stainless steel channel that wraps the door edge and protects the door edges from damage by carts, beds, and equipment. Other models offer protection to the jamb with a wrap-around guard. Refer to individual catalog pages for additional information. Edge guards for the latch side edge of the door are available through our Trim & Auxiliary product line.

### **Dutch Door Hinges**

The frame leaf is furnished as a continuous leaf and the door leaf is cut to fit the dutch door heights specified. Upper and lower door leaves are prepped for extra screws. Handing, overall net door height, amount of clearance between the top and bottom doors, their individual heights and door and frame materials should be clearly specified.

### **Non-Rising Pin**

The pin is held securely in place and will not rise or fall from the knuckles during use. The top and bottom plugs are permanently secured to the hinge.

### **Raised Barrel**

For applications where the door is set back in the frame, the knuckle is offset to allow the hinge to clear the frame.

### **Replacement Moldings**

Brushed aluminum replacement moldings with molding clips and fasteners are available in stock lengths for trimming in the field. This option is available for 790-903, 790-904, 790-906, 790-909.

### **Sheared Leaf**

For narrow door thicknesses, leaf width can be trimmed. This option is available for 790-900, 790-903, 790-905, 790-909, 790-911, 790-915, 790-926.

### **Dust Free Bearings**

Provide a clean and quiet operation as they prevent metal on metal wearing.

### **Tamper Resistant Hospital Tip**

Concealed models, specifically 790-905 and 790-915, can be prepared with a tapered, 45° angled tip at the top of the hinge. These modified hinges are ideal for use in hospitals and correctional facilities to help provide a clean and safe environment.



## FASTENERS

Hager Companies 790 Series stainless steel continuous hinges are provided exclusively with carefully engineered and thoroughly tested fasteners. Each fastener is designed for ease of use as well as durability. Appropriate fasteners are furnished with each hinge, together with installation instructions for typical metal and wood doors hung on metal frames. The standard screw pack includes Dril-Kwik<sup>®</sup> self-drilling screws for metal doors and frames as well as wood screws for wood doors.

Special adjustment studs and screws are standard on all models with the double door edge protection lip. The special adjustment studs and screws allow correction of door fit problems up to 3/8" (9 mm). Sex bolts are optional and must be requested at time of order. If special fasteners are required, customers must supply them except upon prior agreement. Please consult Hager Technical Service for alternate fastener recommendations.

### Optional Sex Bolts

On all applicable full-surface and half-surface mounted hinge models, sex bolts can be ordered. Sex bolts are intentionally designed shorter than the door thickness to ensure proper clamping action of 1-3/4" (44 mm) doors of slightly varying thickness.

### Security Fasteners

These fasteners improve building security and reduce hinge tampering. Security Torx are available in place of standard fasteners upon request.

### Security Studs

These stainless steel security studs are mounted through the frame leaf into the door frame. Security studs are available in place of standard fasteners upon request.

### Fastener Installation

Fasteners for both metal and wood applications are supplied standard with each hinge. The Dril-Kwik<sup>®</sup> self-drilling screw is used in metal door and frame applications and has an undercut head and a machine thread on the screw shank. The type AB wood screw is supplied for wood door and frame applications.

The Dril-Kwik<sup>®</sup> self-drilling screw's drill point allows it to be placed without pre-drilled holes when installed in a hollow metal frame less than 1/8" (3 mm) thick. It forms its own threads as it is drilled into the frame.

Mortar Guards, made of either styrofoam or wood, are recommended for new construction, eliminating the use of masonry bits. For existing grout-filled frames, pre-drilling is required before installation of the Dril-Kwik<sup>®</sup> self-drilling screws. Here, the screw acts as a machine screw since drilling has already taken place. Center-punching is recommended on both hollow metal and grout-filled frames to ensure that the screw seats properly in the hinge leaf. Stainless steel frames require pre-drilling.

In all cases, care should be taken to ensure that no drill chips build up behind the hinge. It is best to pre-mark the holes and pre-drill with the hinge removed or clamp the hinge very tightly against the door or frame when using the self-drilling screws.

When installing the self-drilling type screw, make certain that the installer is familiar with the proper use and torque settings of a screw gun. Proper center-punching is extremely important with self-drilling screws. If center-punching is omitted or incorrectly done, the screw will "walk" in the same way as a drill bit, resulting in cocked screw heads and improperly closing hinges.

## GENERAL INFORMATION - DOOR AND FRAME DIMENSIONING

### Models 790-900, 790-911, 790-915

Designed primarily for work involving new doors and frames.  
Clearance required as follows:

#### Single Doors (Square and Beveled Edged)

A. Hinge thickness	7/32"	5.6 mm
B. Additional allowance for frame irregularities	1/32"	0.8 mm
C. Lockside clearance for single door	1/8"	3.2 mm
Total	3/8"	9.5 mm

#### Pairs of Doors (Square and Beveled Edged)

A. Hinge thickness	7/32"	5.6 mm
B. Additional allowance for frame irregularities	1/32"	0.8 mm
C. Clearance between doors (recommended)*	3/16"	4.8 mm
D. Second hinge thickness	7/32"	5.6 mm
E. Second allowance for frame irregularities	1/32"	0.8 mm
Total	11/16"	17.5 mm

#### Notes:

- Some minimal clearance may be required for paint and/or weatherstripping.
- For doors that are pre-beveled 1/8" (3.2 mm)-in-2" (51 mm) on the hinge edge, add 1/32" (0.8 mm) per door to the TOTAL clearance shown (Model 790-900 only). For Models 790-911 and 790-915, the hinge edge of the door should not be beveled.

### Models 790-905, 790-926

Designed primarily for work involving new doors and frames.  
Clearance required as follows:

#### Single Doors (Square and Beveled Edged)

A. Hinge thickness	9/32"	7.1 mm
B. Additional allowance for frame irregularities	1/32"	0.8 mm
C. Lockside clearance for single door	1/8"	3.2 mm
Total	7/16"	11.1 mm

#### Pairs of Doors (Square and Beveled Edged)

A. Hinge thickness	9/32"	7.1 mm
B. Additional allowance for frame irregularities	1/32"	0.8 mm
C. Clearance between doors (recommended)*	3/16"	4.8 mm
D. Second hinge thickness	9/32"	7.1 mm
E. Second allowance for frame irregularities	1/32"	0.8 mm
Total	13/16"	20.6 mm

#### Notes:

- Some minimal clearance may be required for paint and/or weatherstripping.
  - Not recommended for use on doors/panels that have a beveled edge on the hinge side.
- \*For fire rated doors, please refer to door manufacturer's requirement for edge to edge clearance to maintain compliance with NFPA requirements.

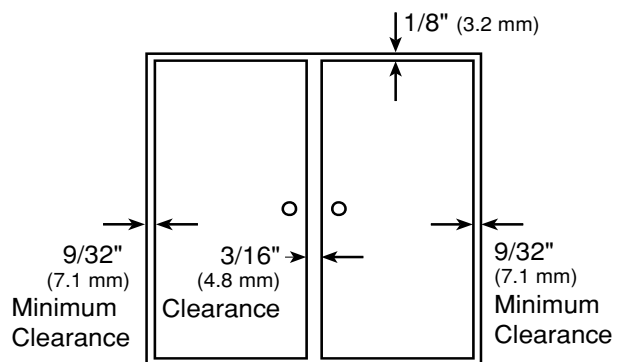
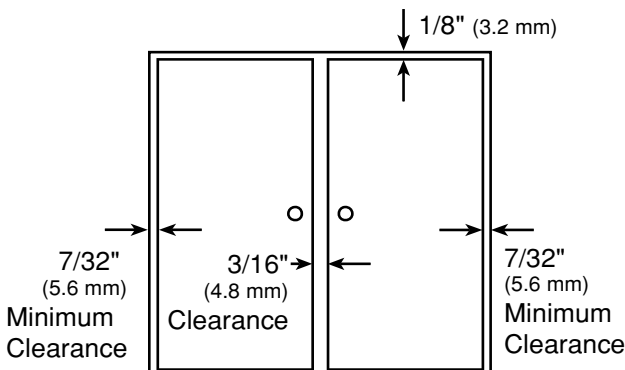
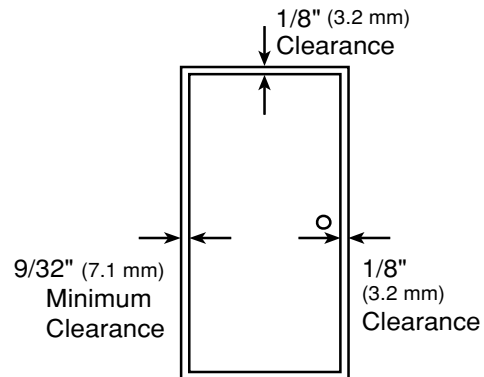
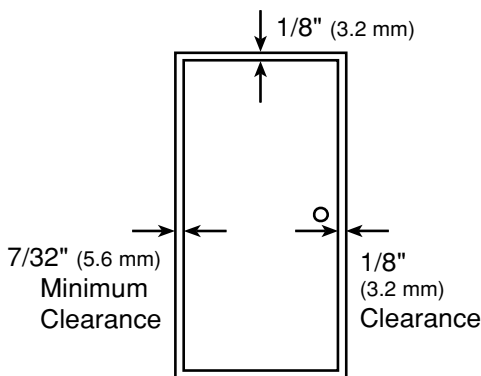



## GENERAL INFORMATION - DOOR AND FRAME DIMENSIONING

### Models 790-903, 790-904, 790-906, 790-909

Designed primarily for work involving new doors and frames.  
Clearance required as follows:

#### Single Doors (Square and Beveled Edged)

A. Hinge thickness	1/8"	3.2 mm
B. Additional allowance for frame irregularities	1/32"	0.8 mm
C. <u>Lockside clearance for single door</u>	<u>1/8"</u>	<u>3.2 mm</u>
Total	9/32"	7.2 mm

#### Pairs of Doors (Square and Beveled Edged)

A. Hinge thickness	1/8"	3.2 mm
B. Additional allowance for frame irregularities	1/32"	0.8 mm
C. Clearance between doors (recommended)*	3/16"	4.8 mm
D. Second hinge thickness	1/8"	3.2 mm
E. <u>Second allowance for frame irregularities</u>	<u>1/32"</u>	<u>0.8 mm</u>
Total	1/2"	12.7 mm

#### Notes for 790-904 only:

- Some minimal clearance may be required for paint and/or weatherstripping.
- For doors that are pre-beveled 1/8" (3.2 mm)-in-2" (51 mm) on the hinge edge, add 1/32" (0.8 mm) per door to the TOTAL clearance shown.

#### Notes for 790-906 only:

- The hinge edge of the door should not be beveled.
- \*For fire-rated doors, please refer to door manufacturer's requirement for edge to edge clearance to maintain compliance with NFPA requirements.

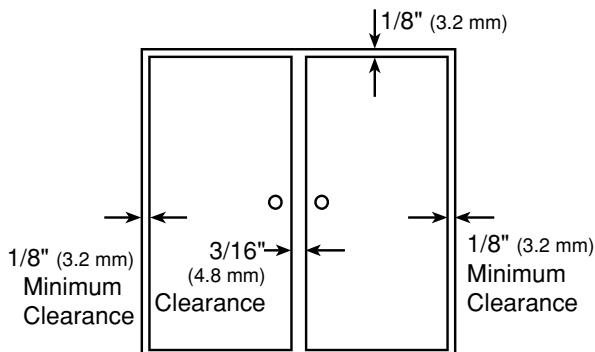
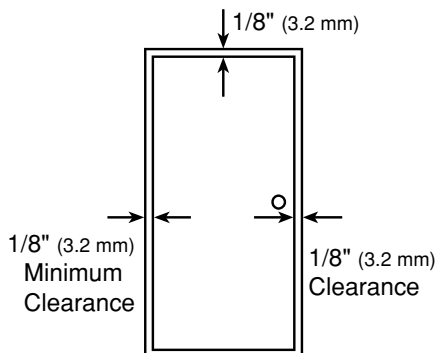

## ELECTRIC MODIFICATIONS

\* For ease of ordering, Hager has established standard locations for power transfer cutouts. All standard location dimensions are referenced from the top edge of the door to the centerline of the power transfer cutout. Please specify handing.

	79"	83"	85"	95"	119"
Opening	80"	84"	86"	96"	120"
Door Height	79-1/8"	83-1/8"	85-1/8"	95-1/8"	119-1/8"
Hinge Length	79-3/16"	83-1/8"	85-1/8"	95"	118-3/4"
ETW	41-1/2"	43-1/2"	45-1/2"	55-3/8"	79-1/8"
EPT	24-1/2"	28-7/16"	30-7/16"	40-1/2"	64-7/16"
E1S	41-1/2"	43-1/2"	45-1/2"	55-3/8"	79-1/8"

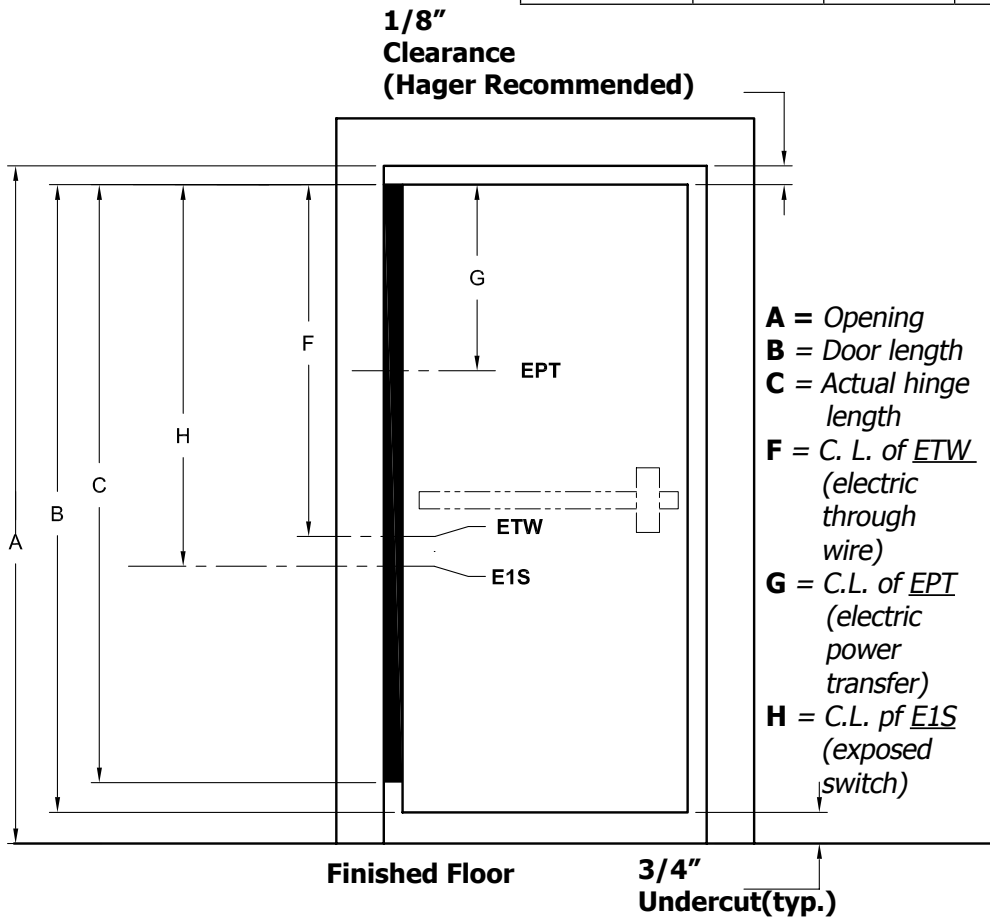

### Concealed Electric Through-Wire:

- Transfers power discreetly from building to door hardware
- Four, eight, or ten 24-gauge wires with 12" wire leads
- To order, use symbol "ETW" plus the number of wires required, as a suffix. Example: 790-900 HD 85" US32D ETW - 4
- Specify handing and dimension from top of hinge to centerline of electric through-wire location. Please note the clearance from top of hinge to underside of header, typically 1/16" to 1/8" (1.6 mm to 3.2 mm).
- Modification available on 790-900 and 790-915

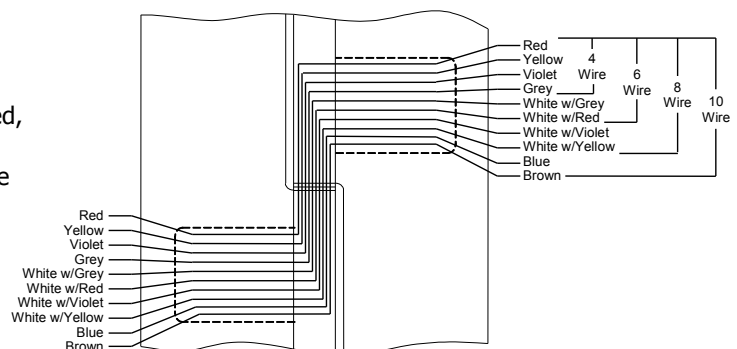



## ELECTRIC MODIFICATIONS

### Von Duprin EPT2 or EPT10 Electric Power Transfer Preparation

- Hinge leaf cutout to accommodate power transfer device
- Specify handing and dimension from top of hinge to centerline of power transfer cutout location. Please note the clearance from top of hinge to underside of header, typically 1/16" to 1/8" (1.6 mm to 3.2 mm).
- Modification available on models 790-900, 790-903, 790-904, and 790-915



### Exposed Electric Switches:

- Miniature push button switch is incorporated in the hinge frame leaf to monitor position of the door.
- Includes three 12" wire leads.
- To order, use symbol "E1S" as a suffix.  
Example: 790-900 85" US32D E1S
- Each monitoring hinge only needs one E1S switch.
- Specify handing and dimension from top of hinge to centerline of electric through-wire location. Please note the clearance from top of hinge to underside of header, typically 1/16" to 1/8" (1.6 mm to 3.2 mm).
- Templates regarding location of contact switch available upon request.
- Modification available on models 790-900 and 790-915.

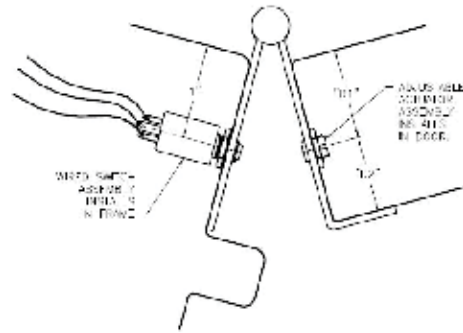

### Quick Connect:

Available for electric through wire option.



### Mortar Box - 430

- Serves as a mortar shield.
- Overall dimensions are 9" (229 mm) length with tabs, 7" (178 mm) (inside), 1-3/4" x 1-3/4" (45 mm x 45 mm) inside dimension.
- Galvanized steel 0.040" (1 mm).
- Top and bottom knockouts for standard conduit fittings.





## CONCEALED LEAF - 790-900 - DOOR OF ANY MATERIAL

### SPECIFICATIONS

Material:	14-gauge 304 stainless steel
Finish:	US32D Satin
Clearance:	7/32" (5.6 mm) hinge side plus standard lockside clearance
Fasteners:	<ul style="list-style-type: none"> <li>• #10-24 x 5/8" S/S Dril-Kwik® (metal frame/door)</li> <li>• #10-16 x 1-1/4" S/S Type AB (wood door)</li> </ul>
Length Options:	Standard and custom lengths available
Door/Frame Reinforcements:	<ul style="list-style-type: none"> <li>• Wood – None required up to 200 lbs.</li> <li>• Metal – Recommended 16-gauge channel for heavier weight</li> <li>• For metal doors, a 1/8" (3.2 mm) thick reinforcement plate is recommended along the hinge edge for proper thread engagement of the adjustment studs</li> </ul>
Fire Rating:	Up to 3 hour metal and 90 minute wood composite

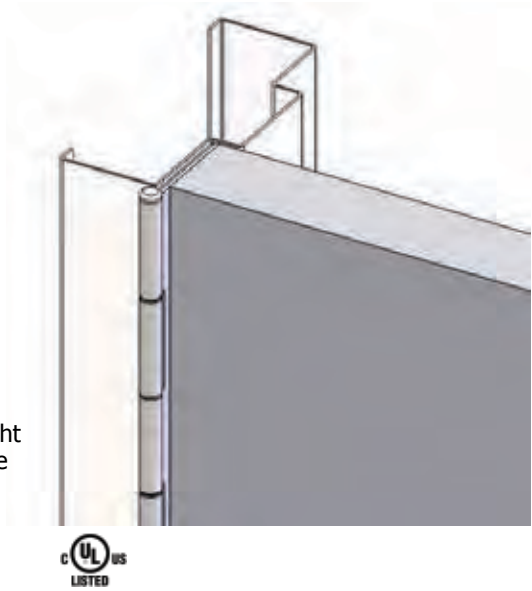

### FEATURES

- For doors 1-3/4" (44 mm) thick and up to 300 pounds
- 1/4" (6.3 mm) diameter stainless steel pin
- Dual 6/6 nylon bearings between each knuckle
- May be used with beveled or square edge doors
- 1/8" (3.2 mm) inset

Length (inches)	79"	83"	85"	95"	119"
Length (mm)	2007	2108	2159	2413	3023
Door Screws	19	21	21	23	27
Jamb Screws	19	21	21	23	27

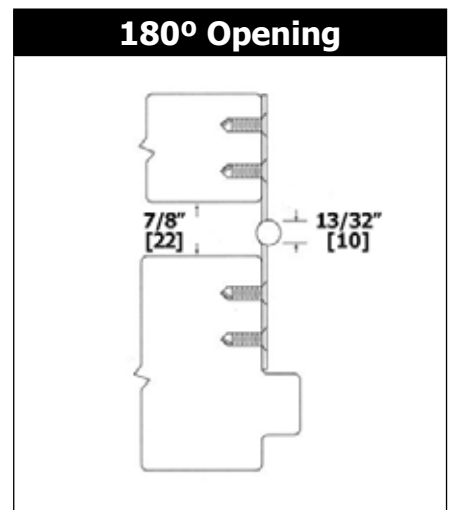
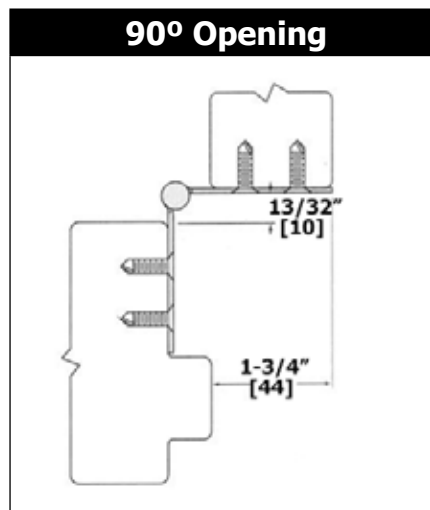
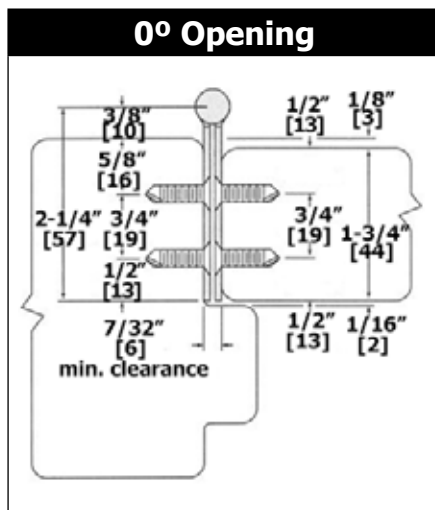



## CONCEALED LEAF - 790-905 - DOOR OF ANY MATERIAL

### SPECIFICATIONS

Material:	14-gauge 304 stainless steel
Finish:	US32D Satin
Clearance:	9/32" (7.1 mm) minimum hinge side plus standard lockside clearance
Fasteners:	<ul style="list-style-type: none"> <li>• #10-24 x 5/8" S/S Dril-Kwik® (metal frame)</li> <li>• #1/4-32 x 3/4" S/S machine screw (used with adjustment stud)</li> <li>• #7/16-20 x 1-3/8" S/S adjustment stud (metal/wood door)</li> </ul>
Length Options:	Standard and custom lengths available
Door/Frame Reinforcements:	<ul style="list-style-type: none"> <li>• Wood – None required up to 200 lbs.</li> <li>• Metal – Recommended 16-gauge channel for heavier weight</li> <li>• For metal doors, a 1/8" (3.2 mm) thick reinforcement plate is recommended along the hinge edge for proper thread engagement of the adjustment studs</li> </ul>
Fire Rating:	Up to 3 hour metal and 90 minute wood composite

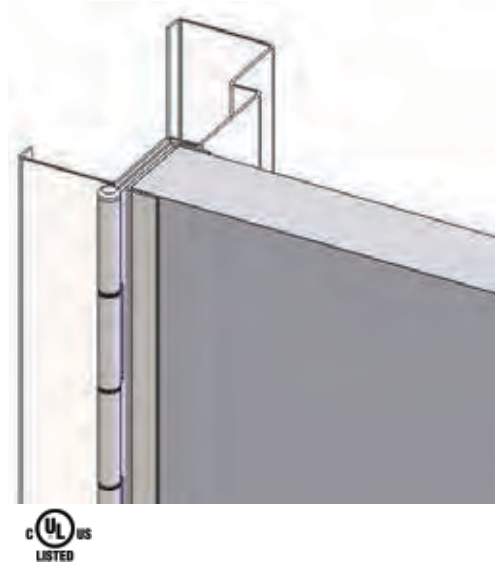

### FEATURES

- For doors 1-3/4" (44 mm) thick and up to 300 pounds
- 1/4" (6.3 mm) diameter stainless steel pin
- Dual 6/6 nylon bearings between each knuckle
- Door edge protection lip (both faces of door)
- Not recommended for doors with a beveled edge on the hinge side
- 1/16" (1.6 mm) inset

Length (inches)	79"	83"	85"	95"	119"
Length (mm)	2007	2108	2159	2413	3023
Door Screws	19	21	21	23	27
Jamb Screws	19	21	21	23	27

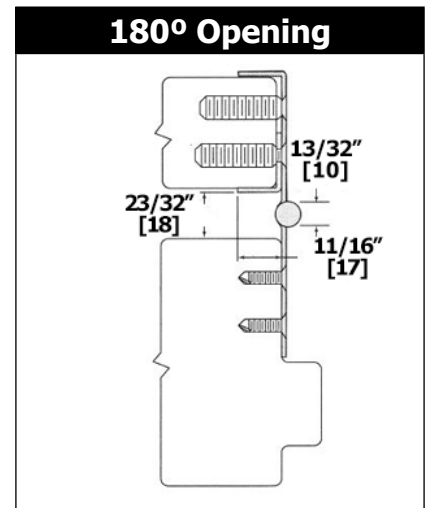
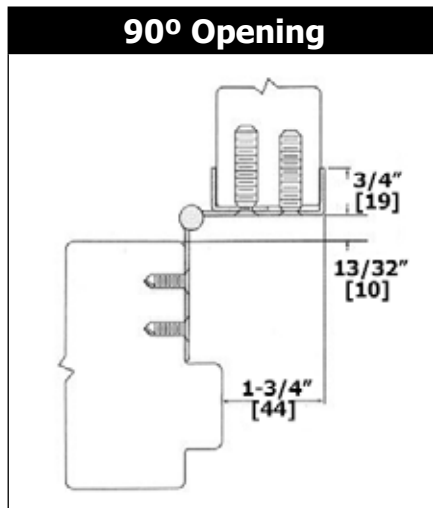
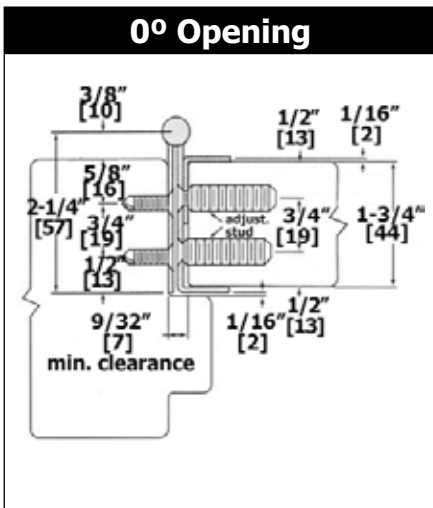

## CONCEALED LEAF - 790-911 - SWING CLEAR - DOOR OF ANY MATERIAL

### SPECIFICATIONS

Material:	14-gauge 304 stainless steel
Finish:	US32D Satin
Clearance:	7/32" (5.6 mm) hinge side plus standard lockside clearance
Fasteners:	<ul style="list-style-type: none"> <li>• #10-24 x 5/8" S/S Dril-Kwik® (metal frame/door)</li> <li>• #10-16 x 1-1/4" S/S Type AB (wood door)</li> </ul>
Length Options:	Standard and custom lengths available
Door/Frame Reinforcements:	<ul style="list-style-type: none"> <li>• Wood – None required up to 200 lbs.</li> <li>• Metal – Recommended 16-gauge channel for heavier weight</li> <li>• For metal doors, a 1/8" (3.2 mm) thick reinforcement plate is recommended along the hinge edge for proper thread engagement of the adjustment studs</li> </ul>
Fire Rating:	Up to 3 hour metal and 90 minute wood composite

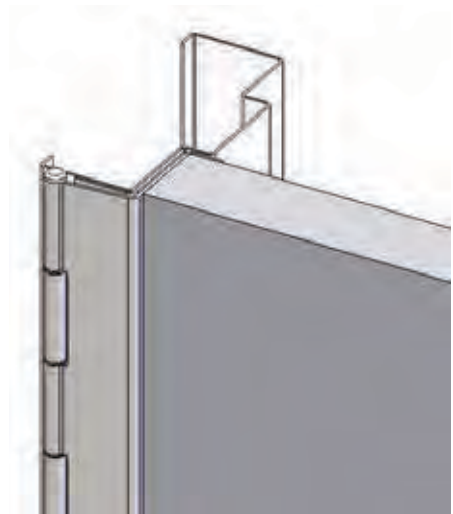

### FEATURES

- For doors 1-3/4" (44 mm) thick and up to 300 pounds
- 1/4" (6.3 mm) diameter stainless steel pin
- Dual 6/6 nylon bearings between each knuckle
- Wrap-around frame leaf design for easy installation and protection
- Door edge protection lip (stop side only)
- Useful for ADA upgrade work
- Not for use on doors with a beveled edge on the hinge side

Length (inches)	79"	83"	85"	95"	119"
Length (mm)	2007	2108	2159	2413	3023
Door Screws	19	21	21	23	27
Jamb Screws	19	21	21	23	27

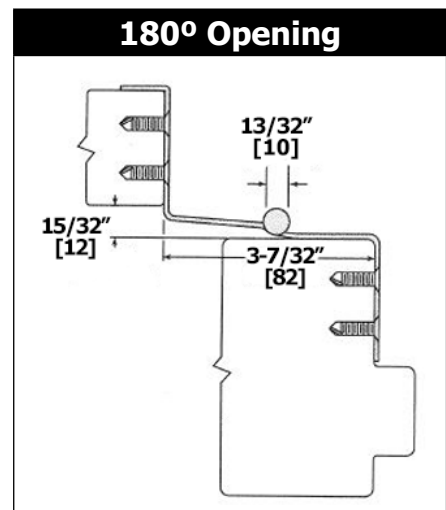
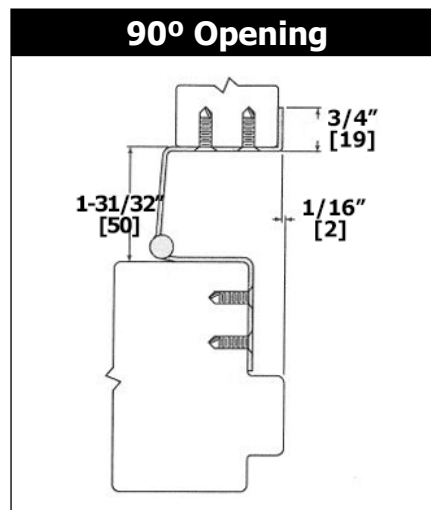
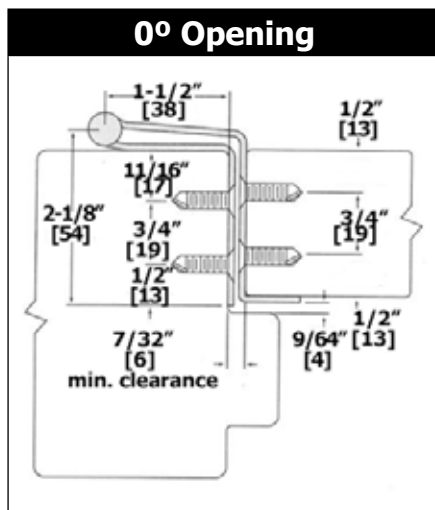



## CONCEALED LEAF - 790-915 - DOOR OF ANY MATERIAL

### SPECIFICATIONS

Material:	14-gauge 304 stainless steel
Finish:	US32D Satin
Clearance:	7/32" (5.6 mm) plus standard lockside clearance
Fasteners:	<ul style="list-style-type: none"> <li>• #10-24 x 5/8" S/S Dril-Kwik® (metal frame/door)</li> <li>• #7/16-20 x 1-1/4" S/S Type AB (wood door)</li> </ul>
Length Options:	Standard and custom lengths available
Door/Frame Reinforcements:	<ul style="list-style-type: none"> <li>• Wood – None required up to 200 lbs.</li> <li>• Metal – Recommended 16-gauge channel for heavier weight</li> <li>• For metal doors, a 1/8" (3.2 mm) thick reinforcement plate is recommended along the hinge edge for proper thread engagement of the adjustment studs</li> </ul>
Fire Rating:	Up to 3 hour metal and 90 minute wood composite

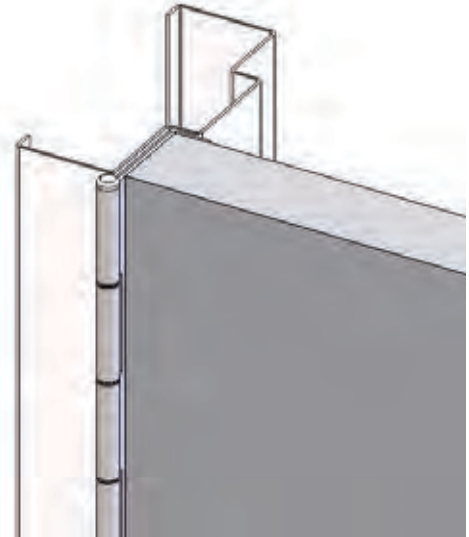

### FEATURES

- For doors 1-3/4" (44 mm) thick and up to 300 pounds
- 1/4" (6.3 mm) diameter stainless steel pin
- Dual 6/6 nylon bearings between each knuckle
- Door edge protection lip (stop side only)
- Not recommended for doors with a beveled edge on the hinge side
- 1/16" (1.6 mm) inset
- Door edge protection lip (stop side only)

Length (inches)	79"	83"	85"	95"	119"
Length (mm)	2007	2108	2159	2413	3023
Door Screws	19	21	21	23	27
Jamb Screws	19	21	21	23	27

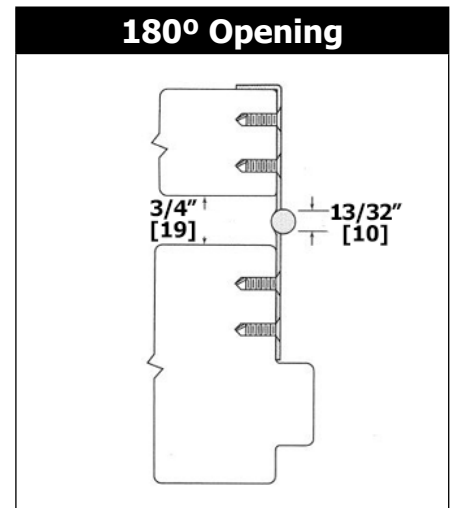
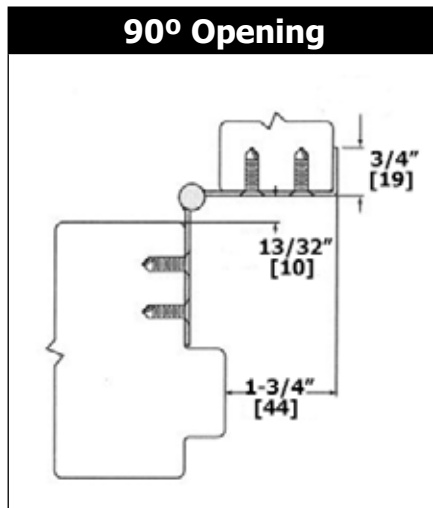
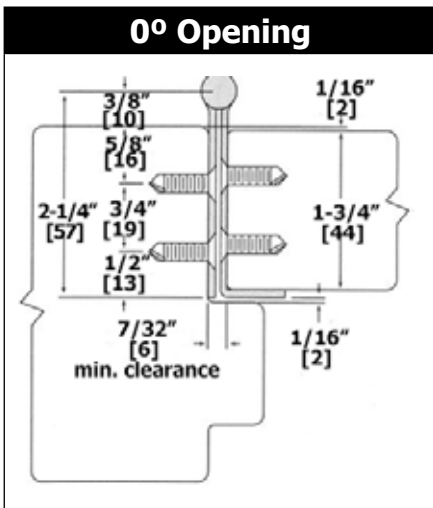

## CONCEALED LEAF - 790-926 - SWING CLEAR - DOOR OF ANY MATERIAL

### SPECIFICATIONS

Material:	14-gauge 304 stainless steel
Finish:	US32D Satin
Clearance:	9/32" (7.1 mm) minimum hinge side plus standard lockside clearance
Fasteners:	<ul style="list-style-type: none"> <li>• #10-24 x 5/8" S/S Dril-Kwik® (metal frame)</li> <li>• #10-32 x 3/4" S/S machine (used with adjustment stud)</li> <li>• #7/16-20 x 1-3/8" S/S adjustment stud (metal/wood door)</li> </ul>
Length Options:	Standard and custom lengths available
Door/Frame Reinforcements:	<ul style="list-style-type: none"> <li>• Wood – None required up to 200 lbs.</li> <li>• Metal – Recommended 16-gauge channel for heavier weight</li> <li>• For metal doors, a 1/8" (3.2 mm) thick reinforcement plate is recommended along the hinge edge for proper thread engagement of the adjustment studs</li> </ul>
Fire Rating:	Up to 3 hour metal and 90 minute wood composite

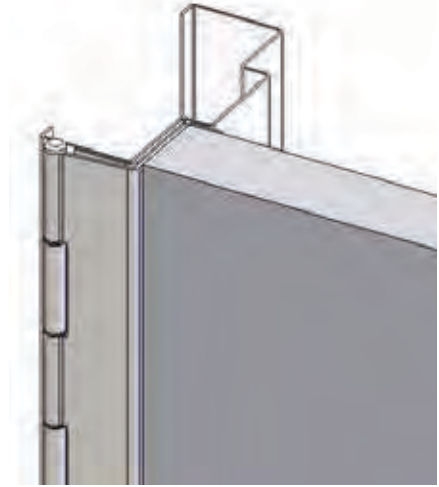

### FEATURES

- For doors 1-3/4" (44 mm) thick and up to 300 pounds
- 1/4" (6.3 mm) diameter stainless steel pin
- Dual 6/6 nylon bearings between each knuckle
- Wrap-around frame leaf design for easy installation and protection
- Door edge protection lip (stop side only)
- Useful for ADA upgrade work
- Not recommended for doors with a beveled edge on hinge side

Length (inches)	79"	83"	85"	95"	119"
Length (mm)	2007	2108	2159	2413	3023
Door Screws	19	21	21	23	27
Jamb Screws	19	21	21	23	27

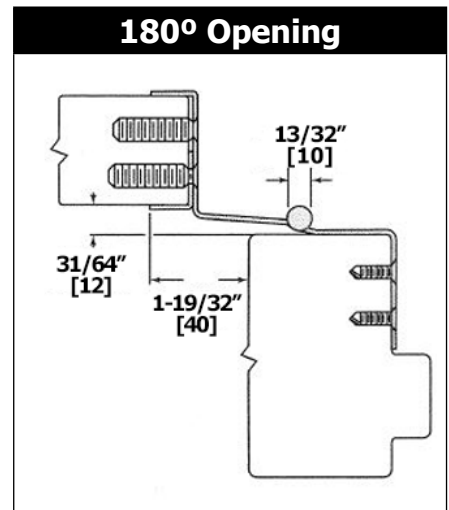
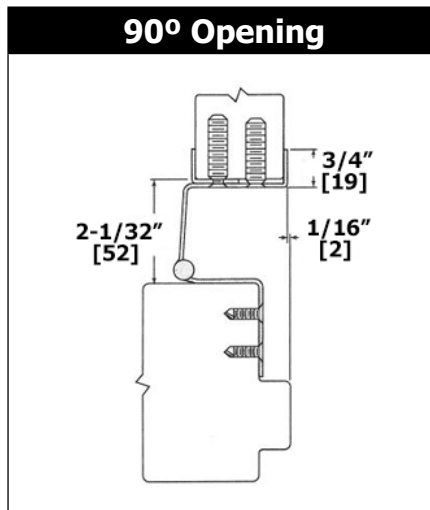
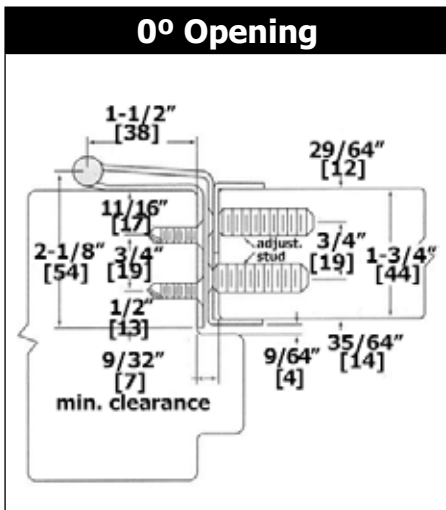



## HALF SURFACE - 790-903 - DOOR OF ANY MATERIAL

### SPECIFICATIONS

Material:	14-gauge 304 stainless steel
Finish:	US32D Satin
Clearance:	1/8" (3.2 mm) minimum hinge side plus standard lockside clearance
Fasteners:	<ul style="list-style-type: none"> <li>• #10-24 x 5/8" S/S Dril-Kwik® (metal frame)</li> <li>• #1/4-20 x 3/4" 2C Dril-Kwik® (metal door)</li> <li>• #1/4-14 x 1" 2C Type AB (wood door)</li> </ul>
Length Options:	Standard and custom lengths available
Door/Frame Reinforcements:	<ul style="list-style-type: none"> <li>• Wood – None required up to 200 lbs.</li> <li>• Metal – Recommended 16-gauge channel for heavier weight</li> <li>• For metal doors, a 1/8" (3.2 mm) thick reinforcement plate is recommended along the hinge edge for proper thread engagement of the adjustment studs</li> </ul>
Fire Rating:	Up to 3 hour metal and 90 minute wood composite

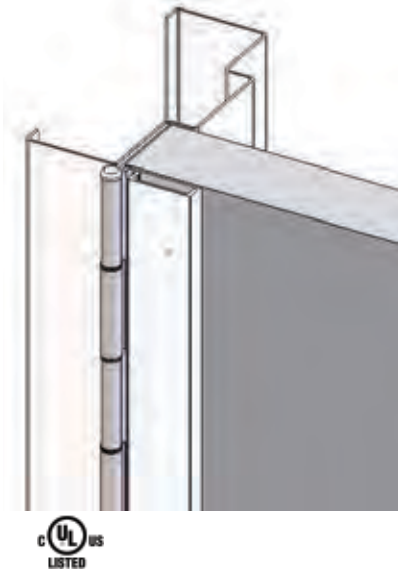

### FEATURES

- For doors 1-3/4" (44 mm) thick and up to 300 pounds
- 1/4" (6.3 mm) diameter stainless steel pin
- Dual 6/6 nylon bearings between each knuckle
- Security molding
- 1/8" (3.2 mm) inset

Length (inches)	79"	83"	85"	95"	119"
Length (mm)	2007	2108	2159	2413	3023
Door Screws	13	14	14	15	18
Jamb Screws	19	21	21	23	27

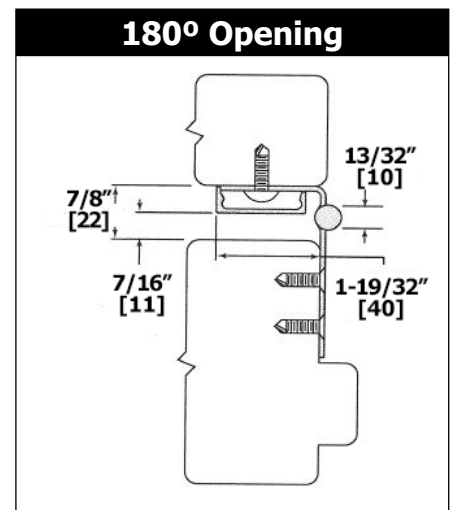
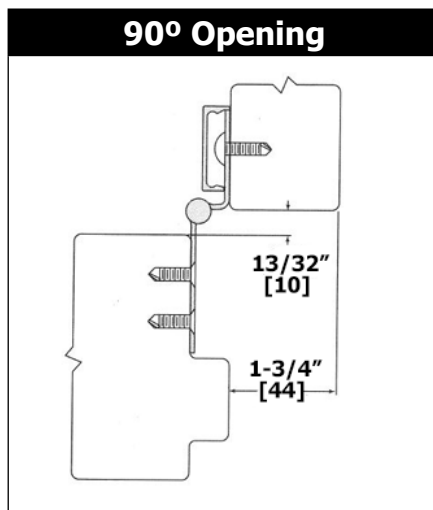
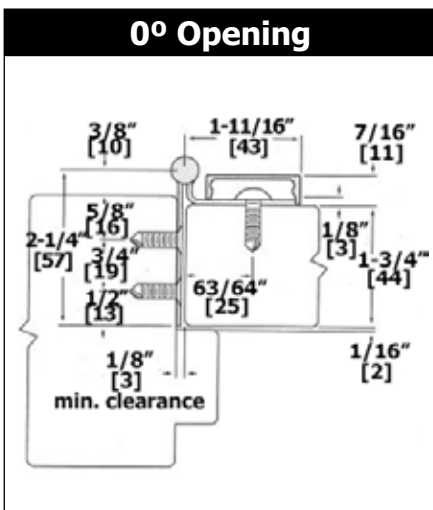

## HALF MORTISE - 790-904 - DOOR OF ANY MATERIAL

### SPECIFICATIONS

Material:	14-gauge 304 stainless steel
Finish:	US32D Satin
Clearance:	1/8" (3.2 mm) hinge side plus standard lockside clearance
Fasteners:	<ul style="list-style-type: none"> <li>• #10-24 x 5/8" S/S Dril-Kwik® (metal door)</li> <li>• #1/4-20 x 3/4" 2C Dril-Kwik® (metal frame)</li> <li>• #10-16 x 1-1/4" S/S Type AB (wood door)</li> </ul>
Length Options:	Standard and custom lengths available
Door/Frame Reinforcements:	<ul style="list-style-type: none"> <li>• Wood – None required up to 200 lbs.</li> <li>• Metal – Recommended 16-gauge channel for heavier weight</li> <li>• For metal doors, a 1/8" (3.2 mm) thick reinforcement plate is recommended along the hinge edge for proper thread engagement of the adjustment studs</li> </ul>
Fire Rating:	Up to 3 hour metal and 90 minute wood composite

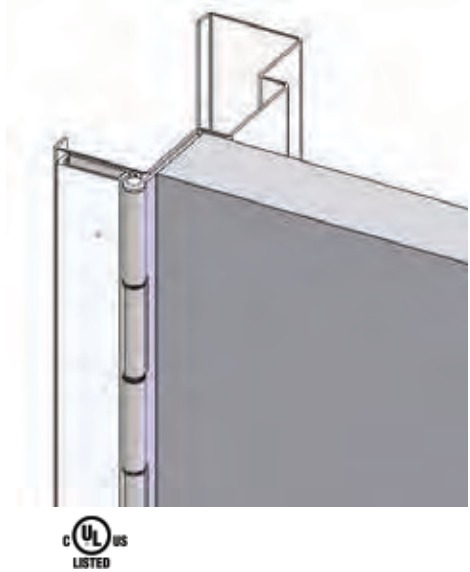

### FEATURES

- For doors 1-3/4" (44 mm) thick and up to 300 pounds
- 1/4" (6.3 mm) diameter stainless steel pin
- Dual 6/6 nylon bearings between each knuckle
- Not recommended for doors with a beveled edge on the hinge side
- 1/8" (3.2 mm) inset

Length (inches)	79"	83"	85"	95"	119"
Length (mm)	2007	2108	2159	2413	3023
Door Screws	19	21	21	23	27
Jamb Screws	13	14	14	15	18

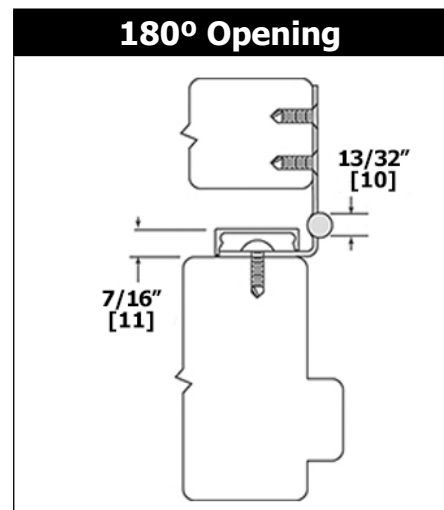
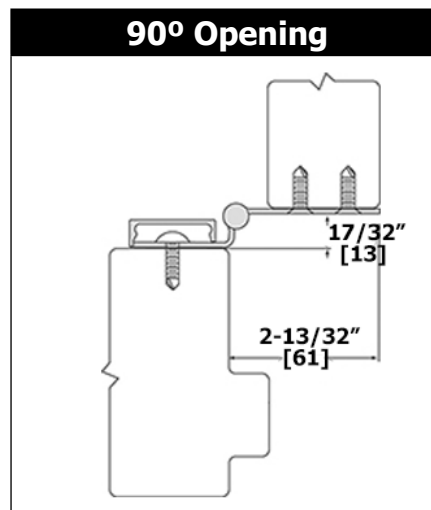
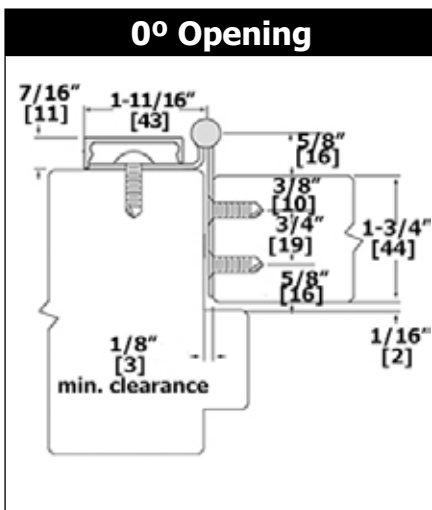



## HALF MORTISE - 790-906 - DOOR OF ANY MATERIAL

### SPECIFICATIONS

Material:	14-gauge 304 stainless steel
Finish:	US32D Satin
Clearance:	1/8" (3.2 mm) minimum hinge side plus standard lockside clearance
Fasteners:	<ul style="list-style-type: none"> <li>• #10-24 x 5/8" S/S Dril-Kwik® (metal door)</li> <li>• #1/4-20 x 3/4" 2C Dril-Kwik® (metal door)</li> <li>• #1/4-14 x 1" 2C Type AB (wood frame)</li> </ul>
Length Options:	Standard and custom lengths available
Door/Frame Reinforcements:	<ul style="list-style-type: none"> <li>• Wood – None required up to 200 lbs.</li> <li>• Metal – Recommended 16-gauge channel for heavier weight</li> <li>• For metal doors, a 1/8" (3.2 mm) thick reinforcement plate is recommended along the hinge edge for proper thread engagement of the adjustment studs</li> </ul>
Fire Rating:	Up to 3 hour metal and 90 minute wood composite

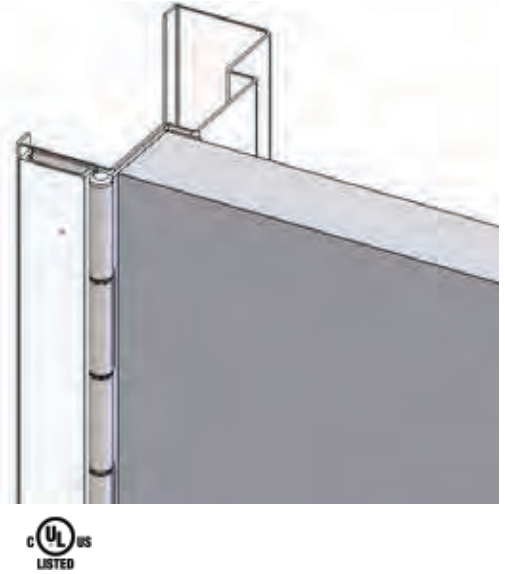

### FEATURES

- For doors 1-3/4" (44 mm) thick and up to 300 pounds
- 1/4" (6.3 mm) diameter stainless steel pin
- Dual 6/6 nylon bearings between each knuckle
- Security molding
- Door edge protection lip (stop side only)
- Not recommended for doors with a beveled edge on the hinge side

Length (inches)	79"	83"	85"	95"	119"
Length (mm)	2007	2108	2159	2413	3023
Door Screws	19	21	21	23	27
Jamb Screws	13	14	14	15	18

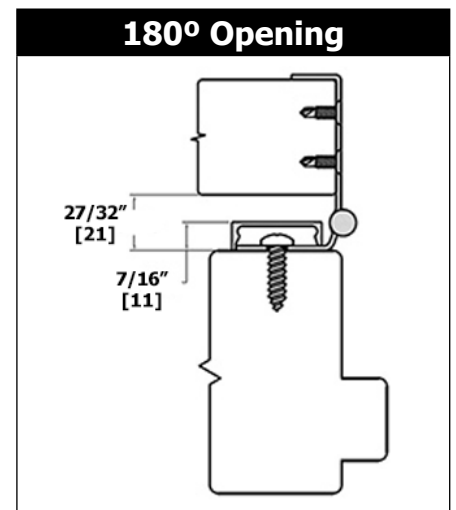
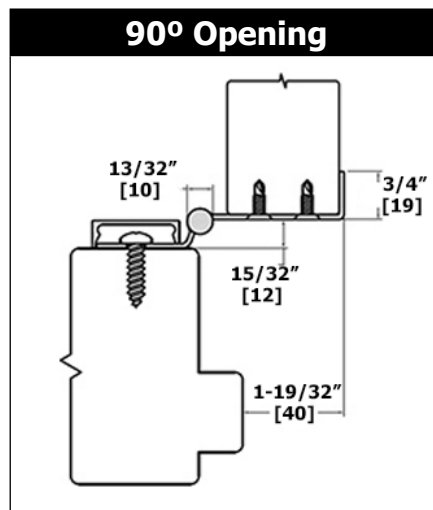
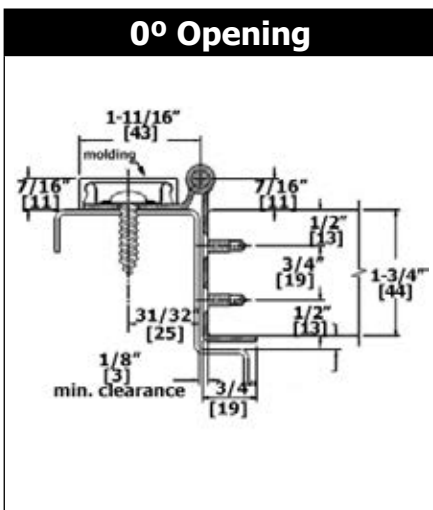



## FULL SURFACE - 790-909 - SWING CLEAR - DOOR OF ANY MATERIAL

### SPECIFICATIONS

Material:	14-gauge 304 stainless steel
Finish:	US32D Satin
Clearance:	1/8" (0.8 mm) minimum recommended hinge side plus standard lockside clearance
Fasteners:	<ul style="list-style-type: none"> <li>• #10-24 x 5/8" S/S Dril-Kwik® (metal frame)</li> <li>• #1/4-20 x 3/4" 2C Dril-Kwik® (metal door)</li> <li>• #1/4-14 x 1" 2C Type AB (wood door)</li> </ul>
Length Options:	Standard and custom lengths available
Door/Frame Reinforcements:	<ul style="list-style-type: none"> <li>• Wood – None required up to 200 lbs.</li> <li>• Metal – Recommended 16-gauge channel for heavier weight</li> <li>• For metal doors, a 1/8" (3.2 mm) thick reinforcement plate is recommended along the hinge edge for proper thread engagement of the adjustment studs</li> </ul>
Fire Rating:	Up to 3 hour metal and 90 minute wood composite

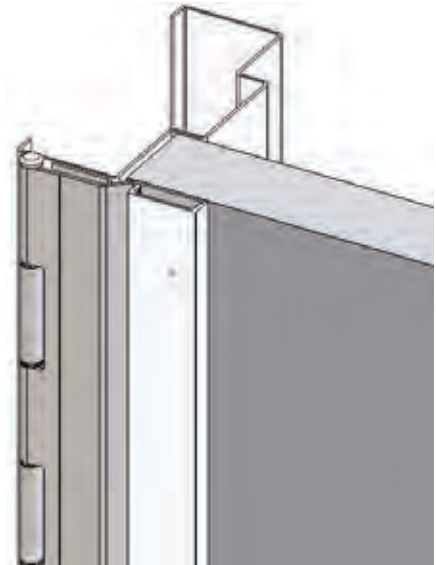

### FEATURES

- For doors 1-3/4" (44 mm) thick and up to 300 pounds
- 1/4" (6.3 mm) diameter stainless steel pin
- Dual 6/6 nylon bearings between each knuckle
- Useful for ADA upgrade work
- Security molding
- For beveled or square edge doors
- 1/8" (3.2 mm) inset

Length (inches)	79"	83"	85"	95"	119"
Length (mm)	2007	2108	2159	2413	3023
Door Screws	19	21	21	23	27
Jamb Screws	13	14	14	15	18

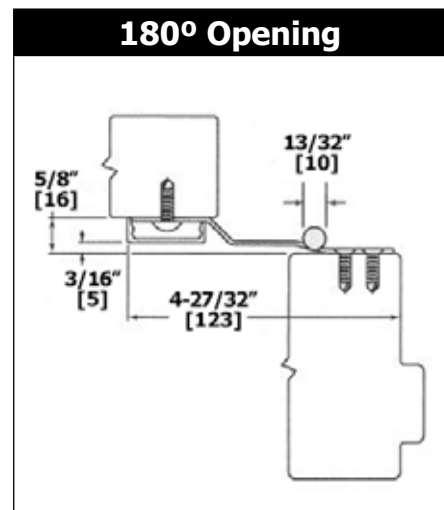
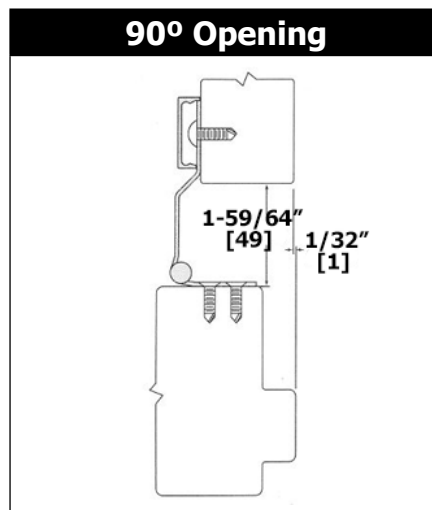
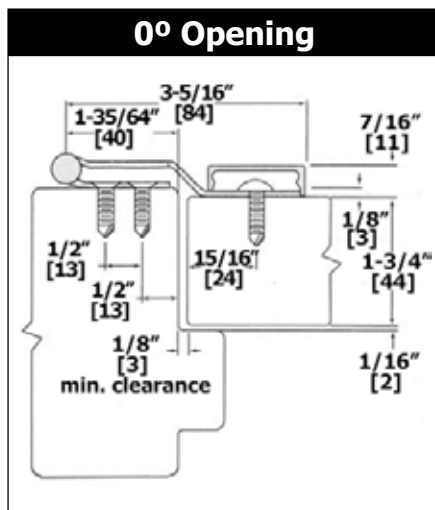



**One Family. One Brand. One Vision.™**

[www.hagerco.com](http://www.hagerco.com)



**One Family. One Brand. One Vision.™**

[www.hagerco.com](http://www.hagerco.com)

# Exit Devices



Every Hager exit device is designed and engineered to assure you and your customers years and years of superior performance in a variety of commercial applications. Hager exit devices use fewer moving parts, are constructed with high quality materials and are backed by industry leading warranties.

All Hager exit devices meet or exceed accepted U.S. domestic and international standards. All are UL listed for panic or fire-rated hardware and comply with ANSI A117.1 for accessible buildings and facilities. Many models are also certified for Hurricane Resistant applications.

Hager exit devices were designed with ease of installation in mind. All are non-handed and packaged for convenience and versatility with thru-bolts, slotted strikes, and both wood and machine screws in every box. Minimal door prep is needed with Hager exit device escutcheon trim with the locking mechanism built inside.

## Table of Contents

<b>4500 Series Heavy Duty Commercial</b> .....	<b>3</b>	<b>4700 Series Standard Duty</b> .....	<b>43</b>
Compliance and Certifications .....	4	Compliance and Certifications .....	44
General Information .....	5	General Information .....	45
Device Profiles .....	6	Device Profile.....	46
How to Order .....	7	How to Order.....	47
Devices .....	8	Devices .....	48
Dummy Pushpad.....	18	Escutcheon Trim .....	50
Alarm Kit.....	19	Key-In-Lever Trim.....	52
Electric Modifications .....	20	Pull Plate Trim .....	54
Escutcheon Trim for Rim and Vertical Rod Devices .....	21	Raised Lip Trim .....	55
Escutcheon Trim for Mortise Device .....	24	Strikes.....	55
Pull Plate Trim .....	26	Accessories.....	56
Strikes.....	27		
Accessories .....	28	<b>4900 Series Mullions</b> .....	<b>59</b>
		How to Order.....	60
<b>4600 Series Narrow Heavy Duty Commercial</b> .....	<b>31</b>	Keyed Removable Mullion .....	61
Compliance and Certifications .....	32	Non-Keyed Removable Mullion .....	62
General Information .....	33	Strikes .....	63
Device Profile .....	34	Stabilizer Kit .....	63
How to Order.....	35	Accessories .....	63
Rim Device .....	36		
Alarm Kit.....	38		
Electric Modifications .....	39		
Escutcheon Trim .....	40		
Strikes .....	42		
Accessories.....	42		





# 4500 Series

**HEAVY DUTY COMMERCIAL APPLICATION**



Hager 4500 Series Exit Devices are ideal for use in heavy duty commercial applications including office buildings, medical facilities, schools, and hospitality structures. The Hager 4500 Series is designed and engineered to provide a lifetime of superior performance on doors in heavy duty commercial applications. Properly applied and maintained Hager 4500 Series Exit Devices and Trim are backed by a lifetime warranty, providing peace of mind from distributor to building owner. Go to [www.hagerco.com](http://www.hagerco.com) for specific warranty conditions.

Hager 4500 Series Exit Devices are BHMA certified Grade 1 and meet Life Safety codes and Fire Safety requirements. The 4500 Series Rim and Surface Vertical Rod devices meet ANSI requirements to be listed as Severe Windstorm Components and are approved for High Velocity Hurricane Zone areas.

Extruded aluminum construction, stainless steel push bar cover, die cast caps and covers, and dead locking stainless steel Pullman type latchbolts provide premium security and performance at value pricing.





## 4500 SERIES - COMPLIANCE & CERTIFICATIONS

### 4500 SERIES DEVICES

BHMA Certified ANSI A156.3 Grade 1



UL305 Listed for Panic Hardware



UL10C Positive Pressure Rated



UL10B Neutral Pressure Rated



Complies with ANSI A117.1 for Accessible Buildings and Facilities



ANSI A 250.13 Severe Windstorm Resistant Component

Miami Dade NOA #11-1219.14

	RIM	SVR	LBR	CVR	CLB	MOR
BHMA Certified ANSI A156.3 Grade 1	YES	YES	YES	YES	YES	YES
UL305 Listed for Panic Hardware	YES	YES	YES	YES	YES	YES
UL10C Positive Pressure Rated	YES	YES	YES	YES	YES	YES
UL10B Neutral Pressure Rated	YES	YES	YES	YES	YES	YES
Complies with ANSI A117.1 for Accessible Buildings and Facilities	YES	YES	YES	YES	YES	YES
ANSI A 250.13 Severe Windstorm Resistant Component	YES	YES	---	---	---	---
Miami Dade NOA #11-1219.14	YES	YES	---	---	---	---

### 4500 SERIES FIRE-RATED DEVICES

UL/cUL Listed for "A" Label Door Up to and Including...

Rim with Fire-rated Removable Mullion 4900UF UL/cUL Listed and Warnock Hersey Listed for "A" Label Door Up to and Including...



VR X VR SAME DIRECTION\*  
UL/cUL Listed for "A" Label Door Up to and Including...

VR X VR Double Egress  
UL/cUL Listed for "A" Label Door Up to and Including...

	RIM F	SVR F	LBR F	CVR F	CLB F	MOR F
UL/cUL Listed for "A" Label Door Up to and Including...	3 HR 4'X8'	3 HR 4'X10'	---	3 HR 4'X10'	---	3 HR 4'X8'
Rim with Fire-rated Removable Mullion 4900UF UL/cUL Listed and Warnock Hersey Listed for "A" Label Door Up to and Including...	3 HR 8'X8'	---	---	---	---	---
VR X VR SAME DIRECTION* UL/cUL Listed for "A" Label Door Up to and Including...	---	90 MIN 8'X10'	90 MIN 8'X8'	90 MIN 8'X10'	90 MIN 8'X8'	---
VR X VR Double Egress UL/cUL Listed for "A" Label Door Up to and Including...	---	3 HR 8'X10'	3 HR 8'X8'	3 HR 8'X10'	3 HR 8'X8'	---

\*Currently, no door manufacturer offers a listing over 90 minutes with doors swinging same direction. Consult wood door manufacturers for current UL listings.



## 4500 SERIES - GENERAL INFORMATION

### Installation Made Easy

For the convenience of our customers, Hager Companies introduced several key features to the exit device market:

- Thru-bolts are included with every model. Wood and machine screws are also provided standard in every package.
- Slotted strikes speed up installation, allowing the installer to make easy adjustments to align the latch to the strike.
- Non-handed device offers added versatility and means less inventory.
- Escutcheon trim is surface mounted with the locking mechanism built inside, reducing door preparation and installation time by requiring fewer holes in the door.

### Shim Kits

Shim kits are available for devices on doors with glass bead kits or other interfacing moldings. Each kit contains two 1/8" (3.2 mm) shims and the appropriate longer fasteners.

### Dogging

Cylinder dogging or less dogging are available to replace the standard hex key dogging on panic exit devices. For cylinder dogging, specify CD on order or purchase 4926 for retrofit applications. Unit requires 1-1/8" mortise cylinder (part number 3902) with standard cam. For less dogging, specify LD on order.

### Sizing

The exit device is cut for 36" (914 mm) and 48" (1219 mm) wide doors. For other door widths, cut exit device to appropriate length. Recommended overall length of exit device is equal to the door width minus four inches. The surface vertical rod devices are supplied for an 84" (2134 mm) opening standard, but can be ordered for a 96" (2438 mm) opening. Extension rods are available to accommodate openings taller than 96" (2438 mm) and up to 120" (3048 mm).

Trim Functions	Part Number	Function Description	ANSI Number
Blank Escutcheon	45BE, 45MB	Always operable (Passage)	14
Cylinder Escutcheon	45CE, 45MC	Key locks or unlocks lever	08
Dummy	45DT, 45MD 45PD	Pull when device is dogged down	02
Night Latch	45NL, 45MN 45PN	Key retracts latchbolt	03
Cylinder Thumbpiece	45PT	Key locks or unlocks thumbpiece	05
Electrified Trim	45ET EL 45ET EU	Fail safe Fail secure	E05 E06

### Applications

#### Single Door (Rim Device)

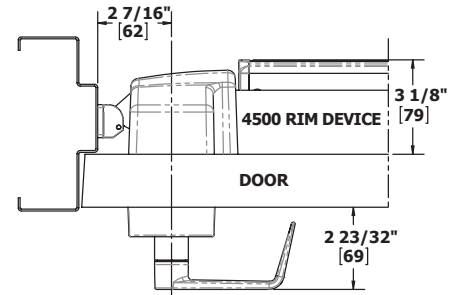

#### Double Door with Mullion (Rim x Rim)

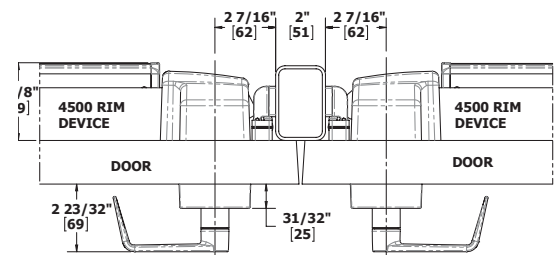

#### Double Door (SVR x SVR)

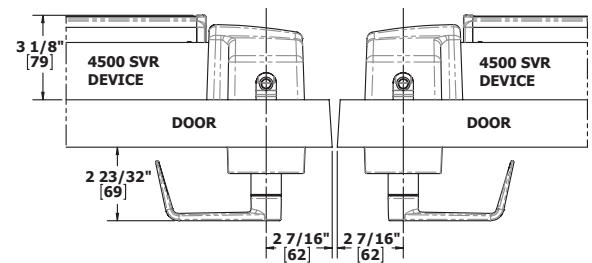

#### Double Door (SVR x Rim)

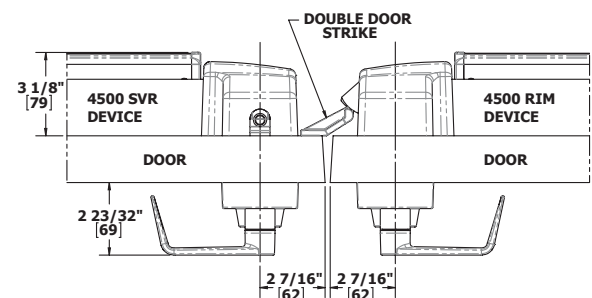





**4500 SERIES - DEVICE PROFILES**

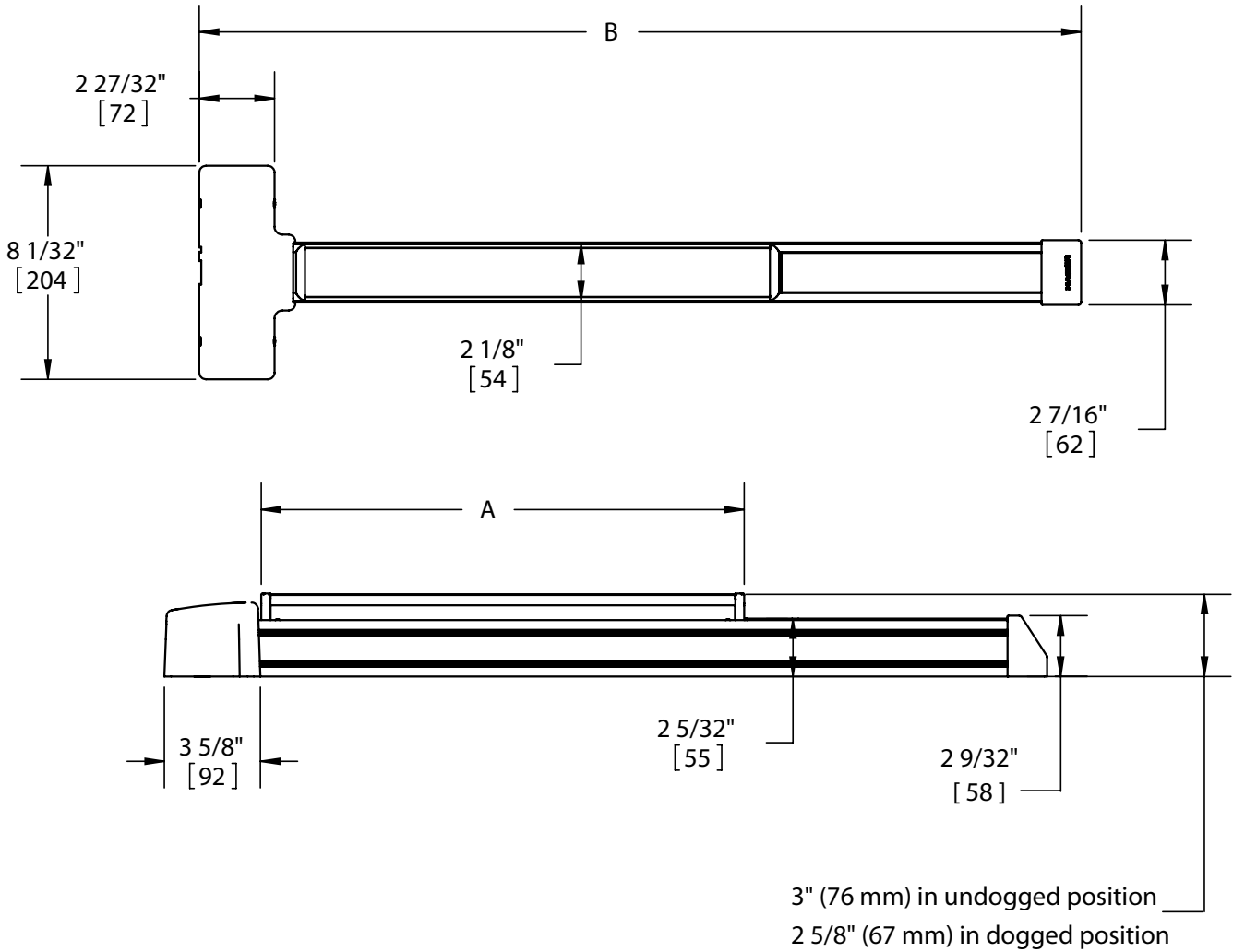

4500 SERIES	A	B
4500 PANIC - 36"	18 5/32"(461mm)	33 5/32"(842mm)
4500 FIRE - 36"		
4500 PANIC - 48"	24"(611mm)	44"(1121mm)
4500 FIRE - 48"		



## 4500 SERIES - HOW TO ORDER

### 4500 SERIES EXIT DEVICE

4501	RIM	F	36"	US3	1-3/4"	ELR
<b>Product Group</b>	<b>Type</b>	<b>Rating</b>	<b>Door Size**</b>	<b>Finish</b>	<b>Door Thickness</b>	<b>Electric Modifications</b>
4500 Series, Grade 1	RIM - Rim Device SVR - Surface Vertical Rod LBR - Surface Vertical Rod Less Bottom Rod * CVR - Concealed Vertical Rod CLB - Concealed Vertical Rod Less Bottom Rod * DMY - Dummy Push Pad MRT - Mortise Device (MC, MB, MD) MRTN - Mortise Night Latch Device (MN)	FR - Fire-Rated 0 - Non-Fire Rated CD - Cylinder Dogging L - Less Dogging WR - Windstorm Rated W - Windstorm and Fire-Rated	36" 48" 36" x 84" 36" x 96" 48" x 84" 48" x 96"	US3 US4 US10 US10B US26 US26D US32D	1-5/8" 1-3/4" 2" 2-1/2" 3"	AI - Authorized Ingress *** ALK - Alarm Kit ALL - Alarm Kit w/ Tamper Switch and Latch Monitor ALM - Alarm Kit w/ Latch Monitor ALT - Alarm Kit w/ Tamper Switch ED - Electric Dogging EDRX - Electric Dogging w/ Request to Exit ELR - Electric Latch Retraction ELRX - Electric Latch Retraction w/ Request to Exit LM - Latchbolt Monitor *** RX - Request to Exit RX2 - Dual Request to Exit RXAI - Request to Exit w/ Authorized Ingress *** RXLM - Request to Exit w/ Latchbolt Monitor *** MLR - Motor Driven Electric Latch Retraction MLRX - Motor Driven Electric Latch Retraction w/ Request to Exit

\*Fire-rated LBR and CLB devices must be ordered in pairs of vertical rod devices or can be used in conjunction with an approved automatic or constant latching flush bolt. When ordering pairs, specify one device LBR and second device LBR with fire bolt, for example: 4501 LBR Fire 36" x 84" plus 4501 LBR Fire 36" x 84" EO with bolt -OR- 4501 LBR Fire 36" x 84" plus an approved automatic or constant latching flush bolt. 24" door size available (Extended lead-time). \*\*\* Not available on Mortise Exit Devices

### 4500 SERIES TRIM

45	CE	ARC	US3	1-3/4"	EL24
<b>Product Group</b>	<b>Trim/Function</b>	<b>Lever Style</b>	<b>Finish</b>	<b>Door Thickness</b>	<b>Options</b>
45 - 4500 Series, Grade 1	BE - Blank Escutcheon Function 14, always operable CE - Cylinder Escutcheon Function 08, key locks/unlocks DT - Dummy Trim Function 02, pull when dogged down ET - Electric Escutcheon Trim NL - Night Latch (1-3/4" to 2-1/2" doors) Function 03, key retracts latchbolt PD - Pull Plate Dummy Trim (Not available for CVR device) Function 02, pull when dogged down PN - Pull Plate Night Latch (Not available for CVR device) Function 03, key retracts latchbolt PT - Thumbpiece Entrance (Not available for CVR device) Function 05, key locks or unlocks thumbpiece VR - Vandal Resistant MB - Mortise Blank Escutcheon (14) * MC - Mortise Cylinder Escutcheon (08) * MD - Mortise Dummy Trim (02) * MN - Mortise Night Latch (03) *	ARC - Archer AUG - August WLM - William WTN - Withnell CHA - Charles JHN - Johnston** JOS - Joshua LOU - Louis WRN - Warren**	US3 US4 US10 US10B US26 US26D US32D (pull plate trim only)	1-5/8" 1-3/4" 2" 2-1/2" 3"	EL12 - Fail Safe, 12 Volt *** EL24 - Fail Safe, 24 Volt *** EU12 - Fail Secure, 12 Volt *** EU24 - Fail Secure, 24 Volt *** TW - Tactile Warning A - Antimicrobial Coating

\* Mortise trim does not match centerline of other 4500 series trim. Cannot be used with 4500 Series Rim or Vertical Rod devices.  
 \*\* Johnston and Warren lever designs are handed - specify LHR/RH or RHR/LH when ordering.  
 ••• Not available on Mortise Exit trim

Notes:

- Mortise cylinder 3902 is required for use with cylinder escutcheon trim and pull plate with thumbpiece trim and is sold separately.
- Rim cylinder with long tailpiece 3901 is required for use with night latch trim and is sold separately.
- For more cylinder information, please refer to Cylinder, Core & Keying in the Locks section of the catalog.
- If using shim kit, specify total door thickness including shims.
- For ET trim, must specify Fail Safe (EL) or Fail Secure (EU) and 12 or 24 volt.



## 4500 SERIES - GRADE 1 RIM DEVICE

### WARRANTY

Lifetime warranty

### FEATURES

#### Certification:

BHMA Certified Grade 1 and meets life safety codes and fire-safety requirements.  
See charts on page 4 for details and options.



#### Covers:

Stainless steel, zinc

#### Cover Tube:

Aluminum

#### Dogging:

- Hex key dogging standard on panic-rated devices
- Less dogging available on panic-rated devices, specify LD
- Cylinder dogging available on panic-rated devices, specify CD (3902 1-1/8" (29 mm) mortise cylinder sold separately)

#### End Caps:

- Zinc
- Flush end cap option available

#### Fasteners:

- Wood and machine screws
- Thru-bolts supplied standard

#### Latchbolt:

3/4" (19 mm) throw, pullman type with automatic dead-latching, stainless steel

#### Strikes:

- Stainless steel with stainless steel pin and roller - included standard with panic device
- Solid stainless steel - included standard with fire-rated device
- Surface applied to frame with slotted holes for easy adjustment
- Double door strike for use with surface vertical rod and rim device available

### SPECIFICATIONS

#### Door Thickness:

1-3/4" (44 mm) - Standard up to 3", except with night latch (NL) which is 2-1/2"

#### Door Width:

- 36" (914 mm) field sizeable to 30" (762 mm) panic-rated door and 28" (711 mm) fire-rated door
- 48" (1219 mm) field sizeable to 36" (914 mm) panic- or fire-rated door

#### Projection:

- 3" (76 mm) in undogged position
- 2-5/8" (67 mm) in dogged position

#### Stile Width:

- 5-3/8" (137 mm) - minimum stile width required for single door and 5/8" (16 mm) stop
- 4-7/8" (124 mm) - minimum stile width required for double door x surface vertical rod with double door strike
- 5-3/4" (146 mm) - minimum stile width required for double doors with 2" (51 mm) mullion
- All stile widths are measured from door edge.

#### Notes:

Recommended for use on appropriately reinforced doors

### TRIM

- 4500 Series excutcheon trim for rim device is surface mounted with a variety of lever options (pp. 22-23)
- Pull plate trim
- Vandal resistant
- Rim cylinder x optional pull

### FINISHES

- US3, US4, US10, US10B, US26, US26D, US32D
- Trim not available in US32D





## 4500 SERIES - GRADE 1 RIM DEVICE - ELECTRIFIED

### WARRANTY

- One-year on electrified components
- Lifetime on hardware components

### FEATURES

Same as 4500 Series Rim Device



### SPECIFICATIONS

#### Door Width:

- 36" (914 mm) field sizeable to 30" (762 mm) panic-rated door and 28" (711 mm) fire-rated door for devices with any monitoring switches
- 48" (1219 mm) field sizeable to 36" (914 mm) panic- or fire-rated door for devices with any monitoring switches
- 36" field sizeable to 34" door minimum for devices with motorized electric latch retraction or delayed egress
- 36" door minimum for devices with solenoid electric latch retraction, electric dogging or alarm kit
- 48" field sizeable to 42" door minimum for devices with solenoid, electric dogging or alarm kit
- 48" field sizeable to 40" door minimum with motorized electric latch retraction or delayed egress

### FUNCTIONS

- ELR - Electric Latch Retraction
- ED - Electric Dogging
- RX - Request to Exit (field installation kit 2-649-5001)
- RX2 - Dual Request to Exit
- ELRX - Electric Latch Retraction with Request to Exit
- EDRX - Electric Dogging with Request to Exit
- ALK - Alarm Kit (kit 4940, tamper switch 2-649-1090)
- AI - Authorized Ingress
- RXAI - Request to Exit with Authorized Ingress
- LM - Latchbolt Monitor (2-649-0168)
- RXLM - Request to Exit with Latchbolt Monitor
- MLR - Motor Driven Electric Latch Retraction (field installation kit 2-649-5007)
- MLRX - Motor Driven Electric Latch Retraction with Request to Exit
- DE - Delayed Egress (must order wall mount controller 2-679-0630 separately)

*Electrical Specifications and Wire Requirements - See 4500 Series Electric Modifications page 20.*



## 4500 SERIES - GRADE 1 SURFACE VERTICAL ROD DEVICE

### WARRANTY

Lifetime warranty

### FEATURES

#### Certification:

BHMA Certified Grade 1 and meets life safety codes and fire-safety requirements. See charts on page 4 for details and options.

#### Covers:

Stainless steel, zinc

#### Cover Tube:

Aluminum

#### Dogging:

- Hex key dogging standard on panic-rated devices
- Less dogging available on panic-rated devices, specify LD
- Cylinder dogging is available on panic-rated devices, specify CD (3902 1-1/8" (29 mm) mortise cylinder sold separately)

#### End Caps:

- Zinc
- Flush end cap option available

#### Fasteners:

- Wood and machine screws
- Thru-bolts supplied standard

#### Latchbolt:

- Top - 1/2" (13 mm) throw, pullman type with automatic dead-latching, stainless steel
- Bottom - 1/2" (13 mm) throw, pullman type, held retracted during door swing, stainless steel

#### Strikes:

- Stainless steel with stainless steel pin and roller - included standard with panic device
- Solid stainless steel - included standard with fire-rated device
- Surface applied to frame with slotted holes for easy adjustment
- 10' (3048 mm) fire-rated device requires strike and hook kit, 4912 for top strike
- Double door strike for use with surface vertical rod and rim device available



### SPECIFICATIONS

#### Door Thickness:

1-3/4" (44 mm) - Standard up to 3", except with night latch (NL) function which is 2-1/2"

#### Door Width:

- 36" (914 mm) field sizeable to 30" (762 mm) panic-rated door and 28" (711 mm) fire-rated door
- 48" (1219 mm) field sizeable to 36" (914 mm) panic- or fire-rated door

#### Projection:

- 3" (76 mm) in undogged position
- 2-5/8" (67 mm) in dogged position

#### Vertical Rods:

- Rods for 7' (2134 mm) doors - 33-1/4" (845 mm) top rod length
- Rods for 8' (2438 mm) doors - 45-1/4" (1149 mm) top rod length
- Extension rods kits available, 2' (610 mm) or 3' (914 mm) for doors over 7'

#### Stile Width:

- 5-3/8" (137 mm) - Minimum stile width required for single door and 5/8" (16 mm) stop
- 4-7/8" (124 mm) - Minimum stile width required for double doors
- 4-7/8" (124 mm) - Minimum stile width required for double door x Rim Device with double door strike
- All stile widths are measured from door edge

#### Notes:

- Center line prep is 40". If door prep elevation is lower, a longer top rod will need to be ordered.
- Recommended for use on appropriately reinforced doors

### TRIM

- 4500 Series escutcheon trim for vertical rod device is surface mounted with variety of lever options (pp. 22-23)
- Pull plate trim (excluding 45PT)
- Vandal resistant
- Rim cylinder x optional pull

### FINISHES

- US3, US4, US10, US10B, US26, US26D, US32D
- Trim is not available in US32D





## 4500 SERIES - GRADE 1 SURFACE VERTICAL ROD DEVICE - LESS BOTTOM ROD (LBR)

### WARRANTY

Lifetime warranty

### FEATURES

#### Certification:

BHMA Certified Grade 1 and meets life safety codes and fire-safety requirements. See charts on page 4 for details and options.

#### Covers:

Stainless steel, zinc

#### Cover Tube:

Aluminum

#### Dogging:

- Hex key dogging standard on panic-rated devices
- Less dogging available on panic-rated devices, specify LD
- Cylinder dogging is available on panic-rated devices, specify CD (3902 1-1/8" (29 mm) mortise cylinder sold separately)

#### End Caps:

- Zinc
- Flush end cap option available

#### Fasteners:

- Wood and machine screws
- Thru-bolts supplied standard

#### Latchbolt:

Top - 1/2" (13 mm) throw, pullman type with automatic dead-latching, stainless steel

#### Strikes:

- Stainless steel with stainless steel pin and roller - included standard with panic device
- Solid stainless steel - included standard with fire-rated device
- Surface applied to frame with slotted holes for easy adjustment
- Double door strike for use with surface vertical rod and rim device available



### SPECIFICATIONS

#### Door Thickness:

1-3/4" (44 mm) - Standard up to 3", except with night latch (NL) function escutcheon trim which is 2-1/2"

#### Door Width:

- 36" (914 mm) field sizeable to 30" (762 mm) panic-rated door and 28" (711 mm) fire-rated door
- 48" (1219 mm) field sizeable to 36" (914 mm) panic- or fire-rated door

#### Projection:

- 3" (76 mm) in undogged position
- 2-5/8" (67 mm) in dogged position

#### Vertical Rods:

- Rods for 7' (2134 mm) doors - 33-1/4" (845 mm) top rod length
- Rods for 8' (2438 mm) doors - 45-1/4" (1149 mm) top rod length
- Extension rod kits available, 2' (610 mm) or 3' (914 mm) for doors over 7'

#### Stile Width:

- 5-3/8" (137 mm) - Minimum stile width required for single door and 5/8" (16 mm) stop
- 4-7/8" (124 mm) - Minimum stile width required for double doors
- 4-7/8" (124 mm) - Minimum stile width required for double doors x rim device with double door strike
- All stile widths are measured from door edge

#### Notes:

- Hole plug for head cover included standard
- Recommended for use on appropriately reinforced doors
- A spring loaded fire bolt 2-649-0166 must be used on fire-rated LBR devices used on a pair of doors to ensure the device's fire rating

### TRIM

- 4500 Series escutcheon trim for vertical rod device is surface mounted with a variety of lever options (pp. 22-23)
- Pull plate trim (excluding 45PT)
- Vandal resistant
- Rim cylinder x optional pull

### FINISHES

- US3, US4, US10, US10B, US26, US26D, US32D
- Trim is not available in US32D



## 4500 SERIES - GRADE 1 SURFACE VERTICAL ROD/LBR DEVICES - ELECTRIFIED

### WARRANTY

- One-year on electrified components
- Lifetime on hardware components

### FEATURES

Same as 4500 Series SVR Device

### SPECIFICATIONS

#### Door Width:

- 36" (914 mm) field sizeable to 30" (762 mm) panic-rated door and 28" (711 mm) fire-rated door for devices with any monitoring switches
- 48" (1219 mm) field sizeable to 36" (914 mm) panic- or fire-rated door for devices with any monitoring switches
- 36" field sizeable to 34" door minimum for devices with motorized electric latch retraction or delayed egress
- 36" door minimum for devices with solenoid electric latch retraction, electric dogging or alarm kit
- 48" field sizeable to 42" door minimum for devices with solenoid, electric dogging or alarm kit
- 48" field sizeable to 40" door minimum with motorized electric latch retraction or delayed egress



### FUNCTIONS

- ELR - Electric Latch Retraction
- ED - Electric Dogging
- RX - Request to Exit (field installation kit 2-649-5001)
- RX2 - Dual Request to Exit
- ELRX - Electric Latch Retraction with Request to Exit
- EDRX - Electric Dogging with Request to Exit
- ALK - Alarm Kit (kit 4940, tamper switch 2-649-1090)
- AI - Authorized Ingress
- RXAI - Request to Exit with Authorized Ingress
- LM - Latchbolt Monitor (2-649-0168)
- RXLM - Request to Exit with Latchbolt Monitor
- MLR - Motor Driven Electric Latch Retraction (field installation kit 2-649-5007)
- MLRX - Motor Driven Electric Latch Retraction with Request to Exit
- DE - Delayed Egress (must order wall mount controller 2-679-0630 separately)

*Electrical Specifications and Wire Requirements - See 4500 Series Electric Modifications page 20.*





## 4500 SERIES - GRADE 1 CONCEALED VERTICAL ROD

### WARRANTY

Lifetime warranty

### FEATURES

#### Certification:

BHMA Certified Grade 1 and meets life safety codes and fire-safety requirements. See charts on page 4 for details and options.

#### Covers:

Stainless steel, zinc

#### Cover Tube:

Aluminum

#### Dogging:

- Hex key dogging standard on panic-rated devices
- Less dogging available on panic-rated devices, specify LD
- Cylinder dogging is available on panic-rated devices, specify CD (3902 1-1/8" (29 mm) mortise cylinder with standard cam sold separately)

#### End Caps:

- Zinc
- Flush end cap option available

#### Fasteners:

- Wood and machine screws
- Thru-bolts supplied standard

#### Latchbolt:

- Top - 1/2" (13 mm) throw, pullman type with automatic dead-latching, stainless steel
- Bottom - 1/2" (13 mm) throw, pullman type, held retracted during door swing, stainless steel

#### Strikes:

- Stainless steel with stainless steel pin and rollers - included standard with panic device
- Solid stainless steel - included standard with fire-rated device
- Top strike mortised into frame
- Double door strike for use with CVR and RIM device available



### SPECIFICATIONS

#### Door Thickness:

1-3/4" (44 mm) - Standard

#### Door Width:

- 36" (914 mm) field sizeable to 30" (762 mm) panic-rated door and 28" (711 mm) fire-rated door
- 48" (1219 mm) field sizeable to 36" (914 mm) panic- or fire-rated door

#### Projection:

- 3" (76 mm) in undogged position
- 2-5/8" (67 mm) in dogged position

#### Vertical Rods:

- Rods for 7' (2134 mm) doors - 34-5/8" (879 mm) top rod length
- Rods for 8' (2438 mm) and 10' (3048 mm) doors - 46-5/8" (1184 mm) top rod length
- Extension rod kits available, 2' (610 mm) or 3' (914 mm) for doors over 7'

#### Stile Width:

- 4" (102 mm) minimum stile width required
- All stile widths are measured from door edge

#### Notes:

- NOT recommended for doors with inset greater than 1/8", for example: double egress frames, or jamb depths over 5-3/4" or greater - for additional information, contact Hager Companies
- Center line prep is 40" (1016 mm) - if door prep elevation is lower, a longer top rod will need to be ordered
- Recommended for use on appropriately reinforced doors

### TRIM

- 4500 Series escutcheon trim for vertical rod device is surface mounted with a variety of lever options (pp. 22-23)
- Pull plate trim (excluding 45PT)
- Vandal resistant
- Rim cylinder x optional pull

### FINISHES

- US3, US4, US10, US10B, US26, US26D, US32D
- Trim is not available in US32D





## 4500 SERIES - GRADE 1 CONCEALED VERTICAL ROD - LESS BOTTOM ROD (CLB)

### WARRANTY

Lifetime warranty

### FEATURES

#### Certification:

BHMA Certified Grade 1 and meets life safety codes and fire-safety requirements. See charts on page 4 for details and options.

#### Covers:

Stainless steel, zinc

#### Cover Tube:

Aluminum

#### Dogging:

- Hex key dogging standard on panic-rated devices
- Less dogging available on panic-rated devices, specify LD
- Cylinder dogging is available on panic-rated devices, specify CD (3902 1-1/8" (29 mm) mortise cylinder with standard cam sold separately)

#### End Caps:

- Zinc
- Flush end cap option available

#### Fasteners:

- Wood and machine screws
- Thru-bolts supplied standard

#### Latchbolt:

Top - 1/2" (13 mm) throw, pullman type with automatic dead-latching, stainless steel

#### Strikes:

- Stainless steel with stainless steel pin and roller - included standard with panic device
- Solid stainless steel - included standard with fire-rated device
- Top strike mortised into frame
- Double door strike for use with CVR and RIM device available



### SPECIFICATIONS

#### Door Thickness:

1-3/4" (44 mm) - Standard

#### Door Width:

- 36" (914 mm) field sizeable to 30" (762 mm) panic-rated door and 28" (711 mm) fire-rated door
- 48" (1219 mm) field sizeable to 36" (914 mm) panic- or fire-rated door

#### Projection:

- 3" (76 mm) in undogged position
- 2-5/8" (67 mm) in dogged position

#### Vertical Rods:

- Rods for 7' (2134 mm) doors - 34-5/8" (879 mm) top rod length
- Rods for 8' (2438 mm) and 10' (3048 mm) doors - 46-5/8" (1184 mm) top rod length
- Extension rod kits available, 2' (610 mm) or 3' (914 mm) for doors over 7'

#### Stile Width:

- 4" (102 mm) minimum stile width required
- All stile widths are measured from door edge

#### Notes:

- NOT recommended for doors with inset greater than 1/8", for example: double egress frames, or jamb depths over 5-3/4" or greater
- A spring loaded fire bolt 2-649-0166 must be used on fire-rated LBR devices used on a pair of doors to ensure the device's fire rating
- Center line prep is 40" (1016 mm) - if door prep elevation is lower, a longer top rod will need to be ordered
- Recommended for use on appropriately reinforced doors

### TRIM

- 4500 Series escutcheon trim for vertical rod device is surface mounted with a variety of lever options (pp. 22-23)
- Pull plate trim (excluding 45PT)
- Vandal resistant
- Rim cylinder x optional pull

### FINISHES

- US3, US4, US10, US10B, US26, US26D, US32D
- Trim is not available in US32D





## 4500 SERIES - GRADE 1 CONCEALED VERTICAL ROD/CLB DEVICES - ELECTRIFIED

### WARRANTY

- One-year on electrified components
- Lifetime on hardware components

### FEATURES

Same as 4500 Series CVR Device

### SPECIFICATIONS

#### Door Width:

- 36" (914 mm) field sizeable to 30" (762 mm) panic-rated door and 28" (711 mm) fire-rated door for devices with any monitoring switches
- 48" (1219 mm) field sizeable to 36" (914 mm) panic- or fire-rated door for devices with any monitoring switches
- 36" field sizeable to 34" door minimum for devices with motorized electric latch retraction or delayed egress
- 36" door minimum for devices with solenoid electric latch retraction, electric dogging or alarm kit
- 48" field sizeable to 42" door minimum for devices with solenoid electric latch retraction, electric dogging or alarm kit
- 48" field sizeable to 40" door minimum with motorized electric latch retraction or delayed egress

#### Notes:

- NOT recommended for doors with inset greater than 1/8", for example: double egress frames, or jamb depths over 5-3/4" or greater
- A spring loaded fire bolt 2-649-0166 must be used on fire-rated LBR devices used on a pair of doors to ensure the device's fire rating

### FUNCTIONS

- ELR - Electric Latch Retraction
- ED - Electric Dogging
- RX - Request to Exit (field installation kit 2-649-5001)
- RX2 - Dual Request to Exit
- ELRX - Electric Latch Retraction with Request to Exit
- EDRX - Electric Dogging with Request to Exit
- ALK - Alarm Kit (kit 4940, tamper switch 2-649-1090)
- AI - Authorized Ingress
- RXAI - Request to Exit with Authorized Ingress
- LM - Latchbolt Monitor (2-649-0168)
- RXLM - Request to Exit with Latchbolt Monitor
- MLR - Motor Driven Electric Latch Retraction (field installation kit 2-649-5007)
- MLRX - Motor Driven Electric Latch Retraction with Request to Exit
- DE - Delayed Egress (must order wall mount controller 2-679-0630 separately)

*Electrical Specifications and Wire Requirements - See 4500 Series Electric Modifications page 20.*





## 4500 SERIES - GRADE 1 MORTISE DEVICE

### WARRANTY

Lifetime warranty

### FEATURES

#### Certification:

BHMA Certified Grade 1 and meets life safety codes and fire-safety requirements. See charts on page 4 for details and options.

#### Covers:

Stainless steel, zinc

#### Cover Tube:

Aluminum

#### Dogging:

- Hex key dogging standard on panic-rated devices
- Less dogging available on panic-rated devices, specify LD
- Cylinder dogging is available on panic-rated devices, specify CD (3902 1-1/8" (29 mm) mortise cylinder with standard cam sold separately)

#### End Caps:

- Zinc
- Flush end cap option available

#### Fasteners:

- Wood and machine screws
- Thru-bolts supplied standard

#### Latchbolt:

3/4" (19 mm) throw with anti-friction tongue, all stainless steel with auxiliary deadlocking latch

#### Strikes:

4-7/8" (124 mm) ASA strike-standard



### SPECIFICATIONS

#### Door Thickness:

1-3/4" (44 mm) - Standard

#### Door Width:

- 36" (914 mm) field sizeable to 30" (762 mm) panic-rated door and 28" (711 mm) fire-rated door
- 48" (1219 mm) field sizeable to 36" (914 mm) panic- or fire-rated door

#### Projection:

- 3" (76 mm) in undogged position
- 2-5/8" (67 mm) in dogged position

#### Stile Width:

- 4-1/2" (114 mm)
- All stile widths are measured from door edge.

#### Notes:

Recommended for use on appropriately reinforced doors

### TRIM

- 4500 Series escutcheon trim for mortise device is available with a variety of lever options (p. 25) (3902, 1-5/8" cylinder with standard cam sold separately)
- Mortise cylinder (1-3/8") with cylinder collar (11/16") x optional pull
- Mortise trim (45MB, 45MC, 45MD, 45MN) does not match center line of other 4500 Series trim (45BE, 45CE, 45DT, 45NL)

### FINISHES

- US3, US4, US10, US10B, US26, US26D, US32D
- Trim is not available in US32D





## 4500 SERIES - GRADE 1 MORTISE DEVICE - ELECTRIFIED

### WARRANTY

- One-year on electrified components
- Lifetime on hardware components

### FEATURES

Same as 4500 Series Mortise Device



### SPECIFICATIONS

#### Door Width:

- 36" (914 mm) field sizeable to 30" (762 mm) panic-rated door and 28" (711 mm) fire-rated door for devices with any monitoring switches
- 48" (1219 mm) field sizeable to 36" (914 mm) panic- or fire-rated door for devices with any monitoring switches
- 36" field sizeable to 34" door minimum for devices with motorized electric latch retraction or delayed egress
- 36" door minimum for devices with electric dogging or alarm kit
- 48" field sizeable to 42" door minimum for devices with electric dogging or alarm kit
- 48" field sizeable to 40" door minimum with motorized electric latch retraction or delayed egress

### FUNCTIONS

- ED - Electric Dogging
- EU/EL - Electrified Mortise Exit Device - provides means of locking/unlocking outside lever trim control remotely
- RX - Request to Exit
- RX2 - Dual Request to Exit
- EDRX - Electric Dogging with Request to Exit
- ALK - Alarm Kit (kit 4940, Latchbolt Monitor 2-649-0168, Tamper Switch 2-649-1090)
- MLR - Motor Driven Electric Latch Retraction (field installation kit 2-649-5007)
- MLRX - Motor Driven Electric Latch Retraction with Request to Exit
- DE - Delayed Egress (must order wall mount controller 2-679-0630 separately)

*Electrical Specifications and Wire Requirements - See 4500 Series Electric Modifications page 20.*



## 4500 SERIES - DUMMY PUSH PAD

<b>WARRANTY</b>	Lifetime warranty
<b>FEATURES</b>	
Application:	For use with 4500 and 4600 Series Exit Devices
Cover Tube:	Aluminum
End Caps:	<ul style="list-style-type: none"><li>• Zinc</li><li>• Flush end cap option available</li></ul>
Fasteners:	<ul style="list-style-type: none"><li>• Wood and machine screws</li><li>• Thru-bolts supplied standard</li></ul>
Available Electric Functions:	<ul style="list-style-type: none"><li>• RX - Request to Exit</li><li>• RX2 - Dual Request to Exit</li></ul>

### SPECIFICATIONS

Door Thickness:	1-3/4" (44 mm) - Standard
Door Width:	<ul style="list-style-type: none"><li>• 36" (914 mm) field sizeable to 27" (686 mm) door</li><li>• 48" (1219 mm) field sizeable to 36" (914 mm) door</li></ul>
Projection:	2-5/8" (67 mm)
Stile Width:	<ul style="list-style-type: none"><li>• 2-1/8" (54 mm) - minimum stile width</li><li>• All stile widths are measured from door edge</li></ul>
<b>FINISHES</b>	<ul style="list-style-type: none"><li>• US3, US10B, US26D, US32D</li></ul>





## 4500 SERIES - 4940 ALARM KIT

### WARRANTY

- One-year on electrified components
- Lifetime on hardware components

### SPECIFICATIONS

Battery:	<ul style="list-style-type: none"><li>• Standard 9-Volt battery required</li><li>• Audible chirp and alternating LED color flash when battery is low</li></ul>
Alarm:	100 decibel horn sounds immediately upon pressing push pad
Cylinder:	<ul style="list-style-type: none"><li>• 1-1/8" or 1-1/4" Mortise cylinders acceptable</li><li>• Hager standard cam required</li><li>• Cylinder sold separately</li></ul>
Activation:	<ul style="list-style-type: none"><li>• Alarm is armed by turning key clockwise</li><li>• Alarm is disarmed by turning the key counter-clockwise</li><li>• Alarm is turned to service mode by turning the key counter-clockwise twice</li></ul>
Alarm Timing:	<ul style="list-style-type: none"><li>• Alarm will sound for either 1, 3, 5 minutes or continuously</li><li>• Times are selectable by on board switches</li></ul>
Warning Decal:	"Emergency Exit Only – Alarm Will Sound" on push pad of exit device
Indicator:	<ul style="list-style-type: none"><li>• LED Indicator</li><li>• Red LED will illuminate intermittently when armed</li><li>• Green LED will illuminate when unarmed</li><li>• Blue LED will illuminate in service mode</li><li>• Alternate colors flash when battery is low</li></ul>
Options:	<ul style="list-style-type: none"><li>• Tamper switch available that sounds alarm when end cap is removed</li><li>• Latch monitor switch is available that sounds alarm when latch is retracted without actuating the push pad</li><li>• Latch monitor switch typically used with Surface Vertical Rod devices</li><li>• When utilizing the latch monitor, the outside trim unit will also sound alarm</li></ul>
Output:	Alarm is equipped with output port





## 4500 SERIES - ELECTRIC MODIFICATIONS

FUNCTION	#	DESCRIPTION
Electric Latch Retraction - Solenoid	ELR	Provides the means of locking or unlocking exit devices remotely. Requires the use of Hager 2901 or 2902 power supply or warranty voided. <i>Note: Mortise Exits require Motor Driven Latch Retraction (MLR).</i>
Electric Dogging	ED	Provides continuous latch retraction and dogging simultaneously.
Request to Exit	RX	Used to shunt an alarm, activate an alarm, provide release of magnetic locks, or signal a console.
Electric Latch Retraction with Request to Exit	ELRX	Provides the means of locking or unlocking exit devices remotely, along with an SPDT switch. Requires the use of Hager 2901 or 2902 power supply or warranty voided. <i>Note: Mortise Exits will require Motor Driven Latch Retraction.</i>
Electric Dogging with Request to Exit	EDRX	Provides continuous latch retraction and dogging simultaneously along with an SPDT switch.
Dual Request to Exit	RX2	Features two SPDT switches
Latchbolt Monitoring	LM	An internal SPDT switch that monitors the latchbolt to signal both egress and access of an opening.
Latchbolt Monitoring/Request to Exit	RXLM	Two internal SPDT switches that monitor the latchbolt and the pushbar simultaneously.
Electric Trim	ET	Provides the means of locking or unlocking outside lever trim controls remotely. Specify Fail Safe (EL) or Fail Secure (EU) and voltage (12V or 24V).
Authorized Ingress/Key Monitoring	AI	An internal SPDT switch that monitors the operation of the outside trim, available for use with either the 45BE, 45CE or 45NL trim or Night Latch by optional pull. Must be ordered with the device.
Request to Exit/Authorized Ingress	RXAI	Two internal SPDT switches that monitor the pushbar and the outside trim simultaneously, available for use with either the 45CE or 45NL trim. Must be ordered with the device.
Delayed Egress	DE	Delays egress for 15 or 30 seconds when unauthorized egress is initiated. Wall mount controller (2-679-0630) provides digital countdown display with verbal instructions or alarm tone only and must be ordered separately.
Motor Driven Electric Latch Retraction	MLR	Provides the means of locking or unlocking exit devices remotely using an electric motor. Recommend Hager 2903 or 2904 Power Supply.
Motor Driven Electric Latch Retraction with Request to Exit	MLRX	Provides the means of locking or unlocking exit devices remotely using an electric motor, along with an SPDT switch. Recommend Hager 2903 or 2904 Power Supply.
Electrified Mortise Exit Device	EU/EL	Provides the means of locking or unlocking outside lever trim controls remotely. Specify Fail Safe (EL) or Fail Secure (EU) and voltage (12V or 24V).

### ELECTRICAL SPECIFICATION/RATINGS AND WIRE REQUIREMENTS

Electrical Specification/Ratings:

- ED; .225 AMP @ 24 Volt +/- 2V
- RX or LM; 125 VAC (3 AMP current); 30 VDC (2 AMP current)
- ELR; Requires 2901/2902 power supply
- MLR; 1 AMP in rush @ 24 VDC +/- 2V, 400 mA holding

Wire Requirements:

- Status switches (i.e. RX, LM, etc.) require 2 wires per switch to monitor a normally open (NO) or normally closed (NC) position
- All devices provide 3 wires per switch so both NO and NC positions can be monitored
- Monitoring both positions will require 3 wires per switch

### QUICK CONNECT

Available on AI, ED, ELR, LM, MLR, and RX

### POWER SUPPLIES

PRODUCT #	DESCRIPTION
2901	For use with 4500/4600 Series electric latch retraction (ELR)
2902	For use with 4500/4600 Series electric latch retraction in a day/night mode of operation (ELR)
2903	Provides 24 Volt DC power for Fail Safe or Fail Secure locking devices and interface with building alarm controls, card readers, keypads, and other door controls
2904	Provides 24 Volt DC power and control for openings with an electrified locking device and automatic door operator
2908	Provides up to 1 amp of 12 or 24 Volt DC power - modular
2909	Provides up to 2 amps of 12 or 24 Volt DC power - modular

**ALARMED DEVICES - SPECIFY WHEN ORDERING** (Note: Alarm kit components may be purchased separately)

**ALK - Alarm Kit**

**ALM - ALK with latch monitor switch (recommended for use with SVR devices)**

**ALT - ALK with tamper switch**

**ALL - ALK with latch monitor and tamper switch**





## 4500 SERIES ESCUTCHEON TRIM - FOR 4500 RIM & VERTICAL ROD DEVICES

### WARRANTY

- One-year on electrified components
- Lifetime on hardware components

### SPECIFICATIONS

Escutcheon: 2-7/8" x 10-3/4" (73 mm x 273 mm)

### Notes:

- Cannot be used with 4500 Series Mortise exit device
- 45BE, 45CE, 45DT, 45NL trim does not match centerline of 4500 Series Mortise trim (45MB, 45MC, 45MD and 45MN)

### LEVERS

Archer, August, Charles, Johnston, Joshua, Louis, Warren, William or Withnell Levers

### FINISHES

US3, US4, US10, US10B, US26, US26D (Not Available in US32D)



#### 45BE

##### Blank Escutcheon

ANSI Function: 14 - Always operable (passage)



#### 45CE

##### Cylinder Escutcheon (Free-wheeling when locked)

ANSI Function: 08 - Key locks or unlocks lever

Cylinder: Requires 3902 mortise cylinder with standard cam (sold separately)



#### 45DT

##### Dummy Trim

ANSI Function: 02 - Pull when device is dogged down



#### 45NL

##### Night Latch

ANSI Function: 03 - Key retracts latchbolt

Cylinder: Requires 3901 rim cylinder with long tailpiece (sold separately)



#### 45ET

##### Electrified Trim (Free-wheeling when locked)

ANSI Function: • 45ET EL- Electric Trim (Fail Safe)

• 45ET EU- Electric Trim (Fail Secure)

Cylinder: Requires 3902 mortise cylinder, 1-1/4" with standard cam (sold separately)

Voltage: 12V or 24V

*Electrical Specifications and Wire Requirements - See 4500 Series Electric Modifications page 20.*





**4500 SERIES - ESCUTCHEON TRIM - LEVER OPTIONS FOR 4500 RIM & VERTICAL ROD DEVICES**

**ARCHER LEVER**

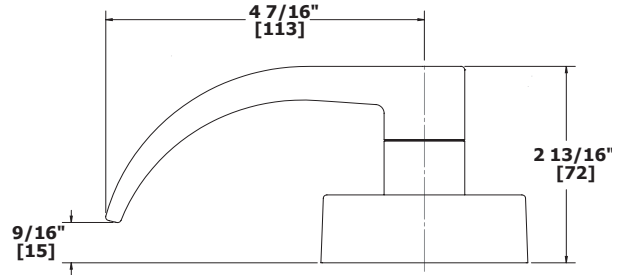

**AUGUST LEVER**

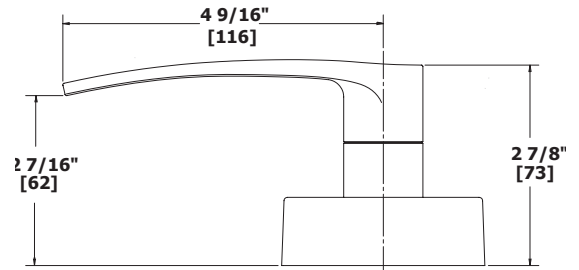

**CHARLES LEVER**

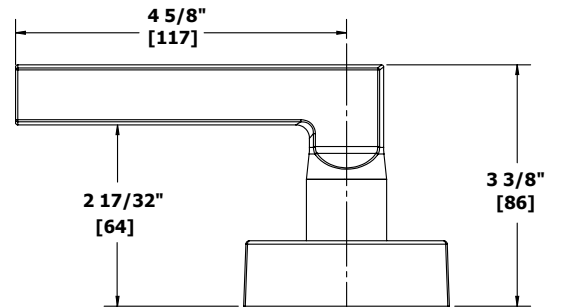

**JOHNSTON LEVER - HANDED**

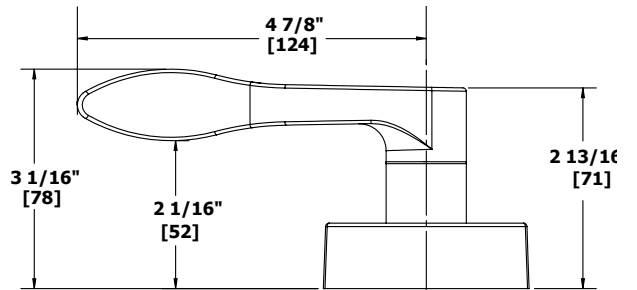

**JOSHUA LEVER**

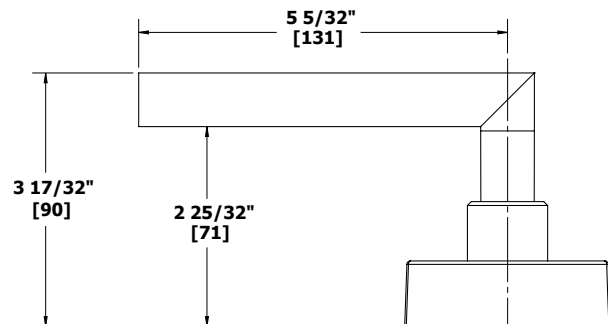



**4500 SERIES - ESCUTCHEON TRIM - LEVER OPTIONS FOR 4500 RIM & VERTICAL ROD DEVICES**

**LOUIS LEVER**

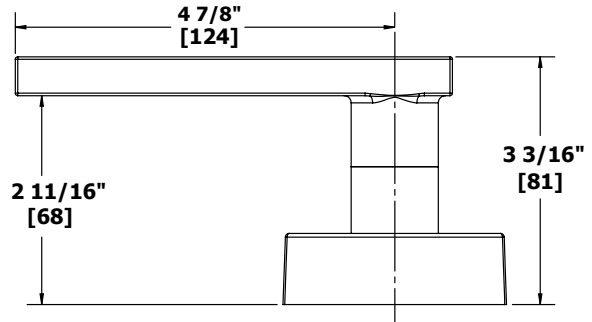

**WARREN LEVER - HANDED**

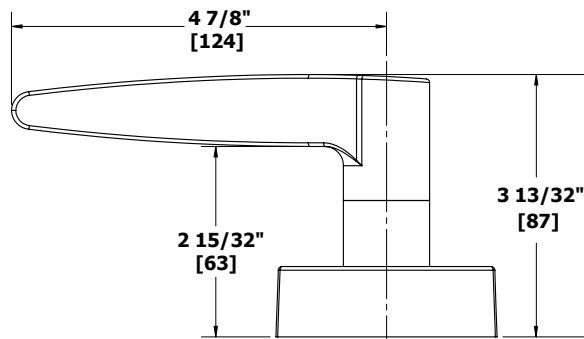

**WILLIAM LEVER**

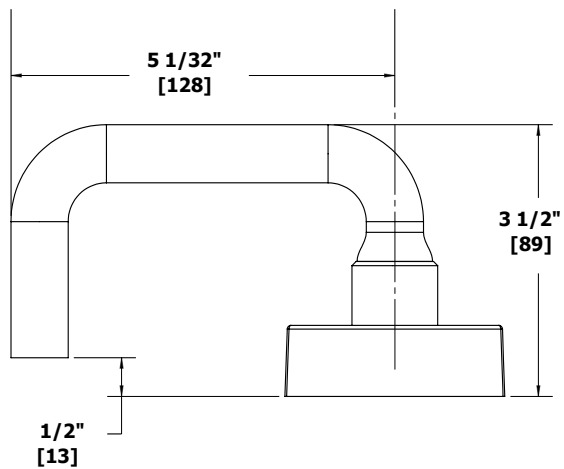

**WITHNELL LEVER**

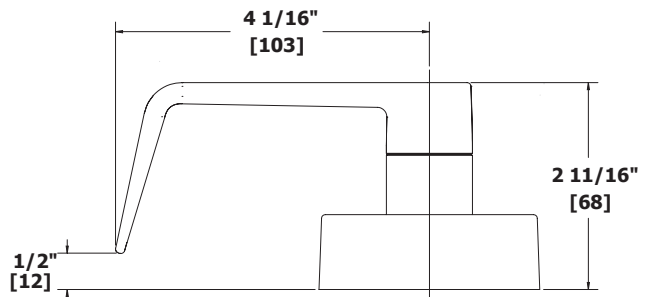



## 4500 SERIES - ESCUTCHEON TRIM - FOR 4500 MORTISE DEVICE

### WARRANTY

- One-year on electrified components
- Lifetime on hardware components

### SPECIFICATIONS

Escutcheon: 2-15/16" x 10" (75 mm x 254 mm)

### Notes:

- Cannot be used with 4500 Series Rim or Vertical Rod devices
- Mortise trim (45MB, 45MC, 45MD, 45MN) does **not** match center line of other 4500 Series trim (45BE, 45CE, 45DT, 45NL)

### LEVERS

Archer, August, William or Withnell Levers (Not Available in US32D)

### FINISHES

US3, US4, US10, US10B, US26, US26D



#### 45MB

**Blank Escutcheon - For Use with 4501M Mortise Exit Device**

ANSI Function: 14 - Always operable (passage)



#### 45MC

**Cylinder Escutcheon - For Use with 4501M Mortise Exit Device**

ANSI Function: 08 - Key locks or unlocks lever (free-wheeling when locked)

Cylinder: Requires 3902, 1-5/8" mortise cylinder with standard cam (sold separately)



#### 45MD

**Dummy Trim - For Use with 4501M Mortise Exit Device**

ANSI Function: 02 - Pull when device is dogged down

Cylinder: Requires 3902, 1-5/8" mortise cylinder with standard cam (sold separately)



#### 45MN

**Night Latch - For Use with 4501N Mortise Exit Device**

ANSI Function: 03 - Key retracts latchbolt

Cylinder: Requires 3902, 1-5/8" mortise cylinder with standard cam (sold separately)





**4500 SERIES - ESCUTCHEON TRIM - LEVER OPTIONS FOR 4500 MORTISE DEVICE**

**ARCHER LEVER**

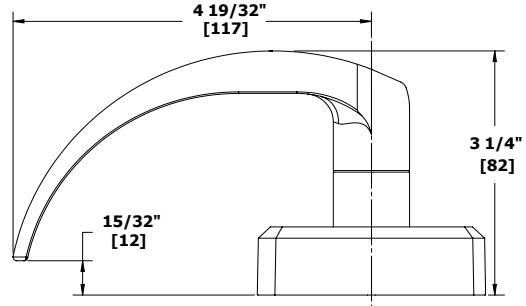

**AUGUST LEVER**

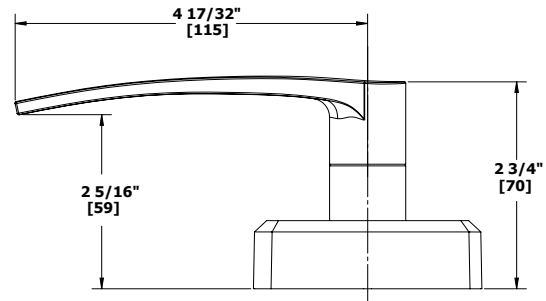

**WILLIAM LEVER**

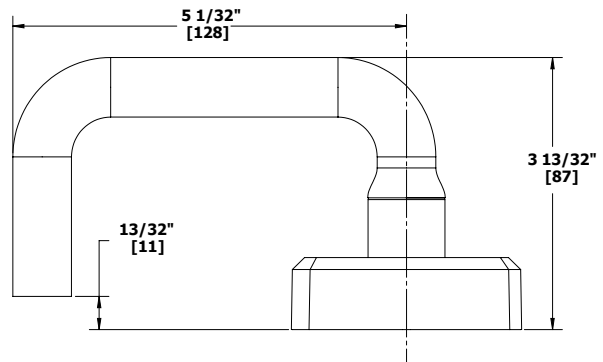

**WITHNELL LEVER**

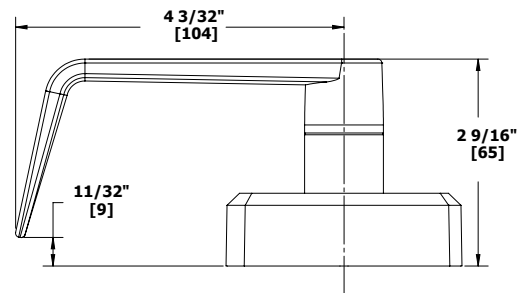



## 4500 SERIES - PULL PLATE TRIM

### SPECIFICATIONS (45PD, 45PN, 45PT)

Plate:	3" x 14" (76 mm x 356 mm)
Projection:	1-3/4" (44 mm)
Pull CTC:	5-1/2" (140 mm)



#### 45PD

##### Dummy Trim

ANSI Function:	02 - Pull when device is dogged down
Finishes:	US3, US4, US10, US10B, US26, US26D, US32D
Notes:	For use with 4500 RIM, SVR, LBR, CLB devices, <u>not</u> for use with CVR



#### 45PN

##### Night Latch

ANSI Function:	03 - Key retracts latchbolt
Finishes:	US3, US4, US10, US10B, US26, US26D, US32D
Cylinder:	Requires 3901 rim cylinder (sold separately)
Notes:	<ul style="list-style-type: none"> <li>Includes retaining cup for 161 door prep</li> <li>For use with 4500 RIM, SVR, LBR, CLB devices, <u>not</u> for use with CVR</li> </ul>



#### 45PT

##### Thumb Piece Pull Plate Trim

ANSI Function:	05 - Key locks or unlocks thumbpiece
Finishes:	US32D
Cylinder:	Requires 3902 mortise cylinder with standard cam (sold separately)
Notes:	For use with 4500 Rim exit only, <u>not</u> for use with vertical rod devices



#### 313S

##### Anti Vandal Pull

Certification:	Meets ANSI A156.6 for J401 Pull and J407 Pull Plate
Size:	6-11/32" x 11" (161 mm x 280 mm)
Projection:	1-7/8" (48 mm)
Clearance:	1-5/8" (41 mm)
Door Thickness:	1-3/4" - 2" (45 mm - 51 mm)
Materials:	11 gauge stainless steel
Finishes:	US32D
Fasteners:	Thru bolts directly to device
Options:	<ul style="list-style-type: none"> <li>Cylinder cutout available 1-1/4" (32 mm) dia. standard for exit device, specify handing</li> <li>Plastisol grip available</li> </ul>
Cylinder:	Cylinder and cylinder collar must be ordered separately <ul style="list-style-type: none"> <li>Requires 2-649-0137 7/16" cylinder collar with 3901 rim cylinder 1-1/4"- 1-3/8" long (see instructions for more detail)</li> </ul>
Notes:	Available with latchguard (specify 313L)



#### RIM Cylinder by Optional Pull

ANSI Function:	03 - Key retracts latchbolt
Finishes:	US3, US4, US10, US10B, US26, US26D, US32D
Cylinder:	Requires 3901 rim cylinder (sold separately). Standard (attached) and long tailpieces in every box.
Notes:	<ul style="list-style-type: none"> <li>For use with 4500 RIM, SVR, LBR, CLB devices, <u>not</u> for use with CVR</li> <li>For pull options see Trim &amp; Auxiliary section</li> </ul>





## 4500 SERIES - STRIKES



**4915  
Threshold Strike**  
Optional strike for use with surface vertical rod exit device and saddle threshold; not for fire-rated doors

Finishes: US32D



**4924  
Bottom Strike**  
Included standard with 4500 Series Vertical Rod exit devices; not for fire-rated doors

Finishes: US32D



**4920  
Strike**  
Included standard with 4500 Series Rim exit devices; not for fire-rated doors

Finishes: US32D

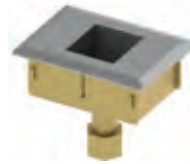

**4924F  
Fire-rated Bottom Strike**  
Included standard with fire-rated 4500 Series Vertical Rod exit devices

Finishes: US32D



**4920F  
Fire-rated Strike**  
Included standard with fire-rated 4500 Series rim exit devices

Finishes: US32D



**4945  
Top Strike**  
Included standard with 4500 Series Concealed Vertical Rod exit devices; not for fire-rated doors

Finishes: US32D



**4921  
Double Door Strike**  
Optional strike to be used with 4500 Series Surface Vertical Rod and Rim exit devices; not for fire-rated doors

Finishes: US3, US4, US10, US10B, US26, US32D



**4945F  
Fire-rated Top Strike**  
Included standard with fire-rated 4500 Series Concealed Vertical Rod exit devices

Finishes: US32D



**4923  
Top Strike**  
Included standard with 4500 Series Surface Vertical Rod exit devices; not for fire-rated doors

Finishes: US32D



### MORTISE EXIT STRIKE

Included standard with 4500 Series Mortise exit device; not for fire-rated doors.

Finishes: US10B (2-649-0205),  
US26D (2-649-0204),  
US32D (2-649-0203)



**4923F  
Fire-rated Top Strike**  
Included standard with fire-rated 4500 Series Surface Vertical Rod exit devices

Finishes: US32D



### FIRE-RATED MORTISE EXIT STRIKE

Included standard with fire-rated 4500 Series Mortise exit device; not for fire-rated doors.

Finishes: US10B (2-649-0208),  
US26D (2-649-0207),  
US32D (2-649-0206)



## 4500 SERIES - ACCESSORIES



### 4926

#### Cylinder Dogging Conversion Kit

For use with panic-rated 4500 Series devices

- Finishes: US3, US4, US10, US10B, US26, US26D, US32D
- Packaging: One (1) each dogging plate, cylinder collar, cash box nut
- Notes:
  - Mortise cylinder 3902 with standard cam, sold separately
  - Specify 36" (914 mm) or 48" (1219 mm)



### 4927

#### Bottom Latch Assembly

For use with 4500 Series Surface Vertical Rod exit device

- Description: 1/2" (13 mm) throw, pullman type, held retracted during door swing, stainless steel
- Finishes: US3, US4, US10, US10B, US26, US26D, US32D
- Packaging: One (1) bottom latch with cover and appropriate fasteners



### 4928

#### Top Latch Assembly

For use with 4500 Series Surface Vertical Rod exit device

- Description: 1/2" (13 mm) throw, pullman type, held retracted during door swing, stainless steel
- Finishes: US3, US4, US10, US10B, US26, US26D, US32D
- Packaging: One (1) top latch with cover and appropriate fasteners



### 2-649-0250/2-649-0257

#### Photoluminescent

Push bar cover option for 4500 & 4600 Series exit devices

- Description: 2-649-0250 - 4500/4600 36"  
2-649-0275 - 4500/4600 48"
- Features:
  - Requires no wiring or maintenance
  - Recharges with exposure to ambient light



### 4929

#### Top/Bottom Rod Replacement Kit

For use with 4500 Series Surface Vertical Rod exit device

- Finishes: US3, US4, US10, US10B, US26, US26D, US32D
- Packaging: One (1) each 45-1/4" (1149 mm) rod, rod guide, rod connector, and appropriate fasteners



### 4929C

#### Concealed Rod Replacement Kit

For use with 4500 Series Concealed Vertical Rod exit device

- Material: Hardened aluminum
- Finishes: US26D
- Packaging: One (1) each 46-5/8" (1184 mm) rod, rod connector and appropriate fasteners



### 4930R

#### Shim Kit

For use with 4500 Series Rim exit devices where a glass bead kit would interfere with exit device

- Finishes: US3, US4, US10, US10B, US26, US26D, US32D
- Packaging: Two (2) each 1/8" (3 mm) shims and appropriate fasteners



### 4930S

#### Shim Kit

For use with 4500 Series Surface Vertical Rod exit devices where a glass bead kit would interfere with exit device

- Finishes: US3, US4, US10, US10B, US26, US26D, US32D
- Packaging: Two (2) each 1/8" (3 mm) shims and appropriate fasteners





## 4500 SERIES - ACCESSORIES



### 4932C

#### Head Cover

For use with 4500 Series Concealed Vertical Rod or Mortise exit devices

Finishes: US3, US4, US10, US10B, US26, US26D, US32D  
 Packaging: One (1) head cover and four (4) each M4 x 6mm MS



### 4932R

#### Head Cover

For use with 4500 Series Rim exit device

Finishes: US3, US4, US10, US10B, US26, US26D, US32D  
 Packaging: One (1) head cover and four (4) each M4 x 6mm MS



### 4932S

#### Head Cover

For use with 4500 Series Surface Vertical Rod exit devices

Finishes: US3, US4, US10, US10B, US26, US26D, US32D  
 Packaging: One (1) head cover and four (4) each M4 x 6mm MS



### 4936

#### 24" Extension Rod Kit

For use with 4500 Series Vertical Rod exit devices

Finishes: US3, US4, US10, US10B, US26, US26D, US32D  
 Packaging: One (1) each 24" (610 mm) extension rod, rod connector, rod guide, plus wood and machine screws  
 Notes: Extension rods threaded on both ends; if cuts are required, cut the standard rod on non-threaded end



### 4937

#### 36" Extension Rod Kit

For use with 4500 Series Vertical Rod exit devices

Finishes: US3, US4, US10, US10B, US26, US26D, US32D  
 Packaging: One (1) each 36" (914 mm) extension rod, rod connector, rod guide, plus wood and machine screws  
 Notes: Extension rod threaded on both ends; if cuts are required, cut the standard rod on non-threaded end



Standard



Flush

#### END CAPS

For use with all 4500 and 4600 Series exit devices

Finishes:	Standard	Flush
US3	(2-649-0038)	(2-649-0218)
US4	(2-649-0039)	(2-649-0220)
US10	(2-649-0040)	(2-649-0214)
US10B	(2-649-0041)	(2-649-0215)
US26	(2-649-0042)	(2-649-0216)
US26D	(2-649-0043)	(2-649-0217)
US32D	(2-649-0044)	(2-649-0219)

Packaging: One (1) each cap and bracket plus fasteners



### 2-649-0166

#### Fire Bolt Kit

For use with fire-rated 4500 Series Vertical Rod less bottom rod device

Faceplate: 1-25/32" x 1" (45 mm x 25 mm)  
 Bolt Diameter: 7/16" (11 mm)  
 Bolt Length: 1-1/2" (38 mm)  
 Materials: Stainless steel  
 Packaging: One (1) each fire bolt, plastic plug, head cover plug, and appropriate fasteners

Notes: Required with a fire-rated pair of LBR or LLB devices to ensure rating





# 4600 Series



## NARROW STILE HEAVY DUTY COMMERCIAL APPLICATION

The Hager 4600 Series is designed and engineered to provide a lifetime of superior performance on narrow stile doors (2-inch minimum) in heavy duty commercial applications. The 4600 Series design complements aluminum and glass construction and provides excellent durability for a range of applications. Properly applied and maintained Hager 4600 Series Exit Devices and Trim are backed by a lifetime warranty, providing peace of mind from distributor to building owner. Go to [www.hagerco.com](http://www.hagerco.com) for specific warranty conditions.

Hager 4600 Series Exit Devices are BHMA certified Grade 1 and meet Life Safety codes and Fire Safety requirements.

Extruded aluminum construction, stainless steel push bar covers, die cast caps and covers, and dead locking stainless steel Pullman type latchbolts provide premium security and performance at value pricing.





## 4600 SERIES - COMPLIANCE AND CERTIFICATIONS

### 4600 SERIES DEVICES

BHMA Certified ANSI A156.3 Grade 1



UL305 Listed for Panic Hardware



UL10C Positive Pressure Rated



UL10B Neutral Pressure Rated



Complies with ANSI A117.1 for Accessible Buildings and Facilities



### 4600 SERIES FIRE-RATED DEVICES

UL/cUL Listed for "A" Label Door Up to and Including 3 hours on 4' x 8' doors

Rim with Fire-rated Removable Mullion 4900UF UL/cUL Listed and Warnock Hersey Listed for "A" Label Door Up to and Including 3 hours on 8' x 8' doors





## 4600 SERIES - GENERAL INFORMATION

### Installation Made Easy

For the convenience of our customers, Hager Companies introduced several key features to the exit device market.

- Thru-bolts are included with every model. Wood and machine screws are also provided standard in every package.
- Slotted strikes speed up installation, allowing the installer to make easy adjustments to align the latch to the strike.
- Non-handed device offers added versatility and means less inventory.
- Escutcheon trim is surface mounted with the locking mechanism built inside, reducing door preparation and installation time by requiring fewer holes in the door.

### Shim Kits

Shim kits are available for devices on doors with glass bead kits or other interfacing moldings. Each kit contains two 1/8" (3.2 mm) shims and the appropriate longer fasteners.

### Dogging

Cylinder dogging or less dogging are available to replace the standard hex key dogging on panic exit devices. For less dogging, specify LD on order. For cylinder dogging, specify CD on order or purchase 4926 for retrofit applications. Unit requires 1-1/8" (29 mm) mortise cylinder (part number 3902) with standard cam.

### Sizing

The exit device is cut for 36" (914 mm) and 48" (1219 mm) wide doors. For other door widths, cut exit device to appropriate length. Recommended overall length of exit device is equal to the door width minus four inches.

Trim Functions	Part Number	Function Description	ANSI Number
Blank Escutcheon	46BE	Always operable (Passage)	14
Cylinder Escutcheon	46CE	Key locks or unlocks lever	08
Dummy	46DT	Pull when device is dogged down	02
Night Latch	46NL	Key retracts latchbolt	03
Night Lever	46NK	Key releases lever; trim locked when key removed	09

### Applications

#### Single Door Panic Exit Hardware - Blade Stop Strike (4950) and Frame

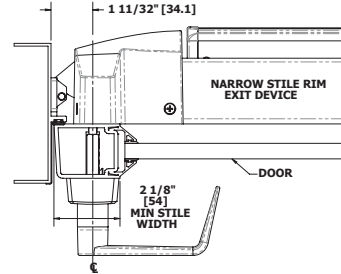

#### Single or Double Door with Panic Exit Hardware - Standard Strike (4920) and Frame

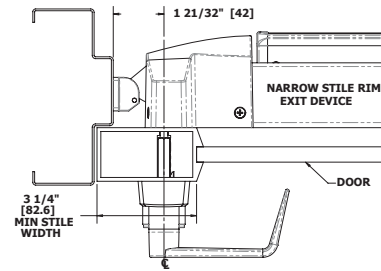

#### Single or Double Door with Panic Exit Hardware - Standard Strike (4920) and Mullion

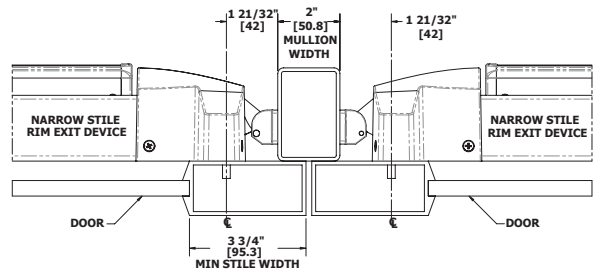

#### Single or Double Door with Panic Exit Hardware - Semi-Flush Mount Strike (4952) and Mullion

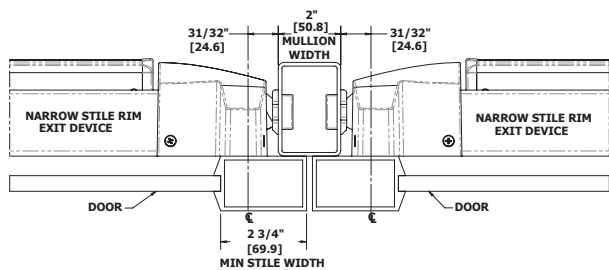



## 4600 SERIES - DEVICE PROFILE

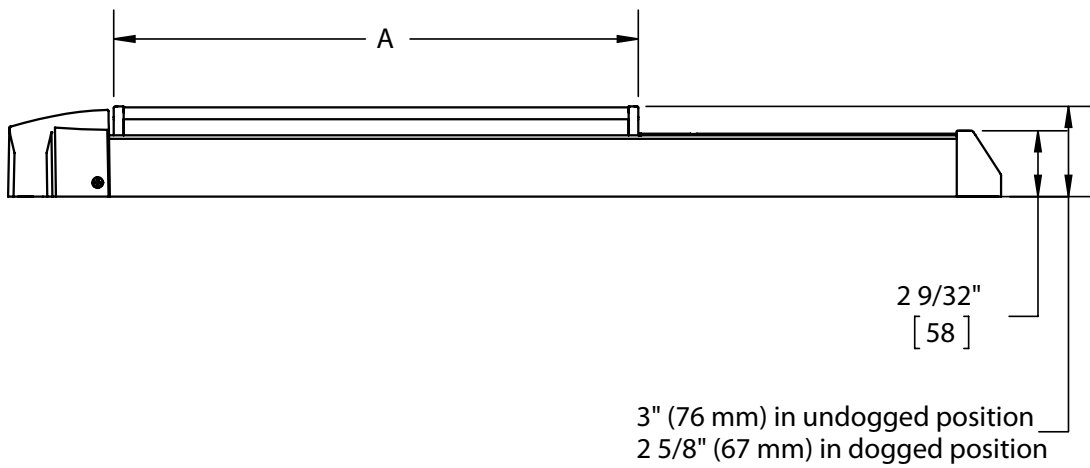
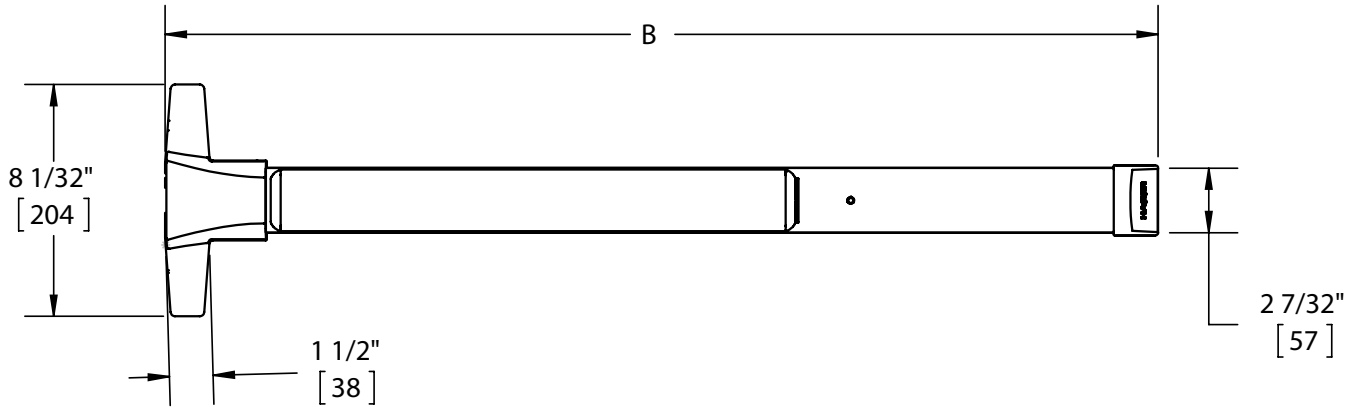

4600 SERIES	A	B
4600 PANIC -36"	18 5/32" (461mm)	34 3/8"(873mm)
4600 FIRE -36"		
4600 PANIC -48"	24"(609mm)	45 13/64"(1148mm)
4600 FIRE -48"		





## 4600 SERIES - HOW TO ORDER

### 4600 SERIES EXIT DEVICE

**4601**

**Product Group**

4600 Series, Grade 1

**RIM**

**Type**

RIM - Rim Device

**F**

**Rating**

F - Fire Rated  
 O - Non-Fire Rated  
 C - Cylinder Dogging  
 L - Less Dogging

**36"**

**Size**

36"  
 48"

**US3**

**Finish**

US3  
 US4  
 US10  
 US10B  
 US26  
 US26D  
 US32D

**1-3/4"**

**Door Thickness**

1-5/8"  
 1-3/4"  
 2"  
 2-1/2"  
 3"

**ELR**

**Electric Modifications**

ALK - Alarm Kit  
 ALL - Alarm Kit w/ Tamper Switch and Latch Monitor  
 ALM - Alarm Kit w/ Latch Monitor  
 ALT - Alarm Kit w/ Tamper Switch  
 ED - Electric Dogging  
 EDRX - Electric Dogging w/ Request to Exit  
 ELR - Electric Latch Retraction  
 ELRX - Electric Latch Retraction w/ Request to Exit  
 LM - Latchbolt Monitor  
 RX - Request to Exit  
 RX2 - Dual Request to Exit  
 RXLM - Request to Exit w/ Latchbolt Monitor  
 MLR - Motor Driven Electric Latch Retraction  
 MLRX - Motor Driven Electric Latch Retraction w/ Request to Exit

### 4600 SERIES TRIM

**46**

**Product Group**

46 - 4600 Series, Grade 1

**CE**

**Trim/Function**

BE - Blank Escutcheon  
 Function 14, always operable  
 CE - Cylinder Escutcheon  
 Function 08, key locks/unlocks lever  
 DT - Dummy Trim  
 Function 02, pull when dogged down  
 NL - Night Latch (Not available for 3" door)  
 Function 03, key retracts latchbolt  
 (for use with 4600 Rim Device only)  
 NK - Night Lever, Function 09, key releases lever,  
 lever locked when key is removed

**ARC**

**Lever Style**

ARC - Archer  
 AUG - August  
 WLM - William  
 WTN - Withnell

**US3**

**Finish**

US3  
 US4  
 US10  
 US10B  
 US26  
 US26D

**1-3/4"**

**Door Thickness**

1-5/8"  
 1-3/4"  
 2"  
 2-1/2"  
 3"

**TW**

**Options**

TW - Tactile Warning  
 A - Antimicrobial  
 Coating

Notes:

1. Mortise cylinder 3902 with 3976 L cam is required for use with cylinder escutcheon trim and is sold separately.
2. Rim cylinder 3901 with long tailpiece is required for use with night latch trim and is sold separately.
3. For more cylinder information, please refer to Cylinder, Core & Keying in the Locks section of the catalog.
4. If using shim kit, specify total door thickness including shims.





## 4600 SERIES - GRADE 1 NARROW STILE RIM DEVICE

### WARRANTY

Lifetime warranty

### FEATURES

#### Certification:

BHMA Certified Grade 1 and meets life safety codes and fire-safety requirements.  
See page 32 for details and options.

#### Covers:

Stainless steel, zinc

#### Cover Tube:

Aluminum

#### Dogging:

- Hex key dogging standard on panic-rated devices
- Less dogging available on panic-rated devices, specify LD
- Cylinder dogging available on panic-rated devices, specify CD  
3902 1-1/8" (29 mm) mortise cylinder with standard cam sold separately

#### End Caps:

- Zinc
- Flush end cap option available

#### Fasteners:

- Wood and machine screws
- Thru-bolts supplied standard

#### Latchbolt:

3/4" (19 mm) throw, pullman type with automatic dead-latching, stainless steel

#### Strikes:

- Blade stop (4950) - Standard with panic device
- Fire-rated strike (4920F) - Standard with fire-rated device
- Standard strike (4920) - Optional
- Single rabbit strike (4951) - Optional
- Semi-flush mount strike (4952) - Optional

### SPECIFICATIONS

#### Door Thickness:

1-3/4" (44 mm) - Standard up to 3", except with night latch (NL) which is 2-1/2"

#### Door Width:

- 36" (914 mm) field sizeable to 30" (762 mm) panic-rated door and 28" (711 mm) fire-rated door
- 48" (1219 mm) field sizeable to 36" (914 mm) panic- or fire-rated door

#### Projection:

- 3" (76 mm) in undogged position
- 2-5/8" (67 mm) in dogged position

#### Stile Width:

- 2-1/8" (54 mm) - Minimum stile width required for 1/2" (13 mm) blade stop frame and 4950 blade stop strike
- 3-1/4" (83 mm) - Minimum stile width required for single door, 5/8" (16 mm) stop and 4920 standard strike
- 3-3/4" (95 mm) - Minimum stile width required for double door x mullion x 4920 strike
- 2-3/4" (70 mm) - Minimum stile width required for double doors with 2" (51 mm) mullion and 4952 semi-flush mount strike
- All stile widths are measured from door edge

#### Notes:

Recommended for use on appropriately reinforced doors

### TRIM

- 4600 Series escutcheon trim for rim device is surface mounted with a variety of lever options (p. 41)
- Rim cylinder x optional pull

### FINISHES

- US3, US4, US10, US10B, US26, US26D, US32D
- Trim not available in US32D





## 4600 SERIES - GRADE 1 NARROW STILE RIM DEVICE - ELECTRIFIED

### WARRANTY

- One-year on electrified components
- Lifetime on hardware components

### FEATURES

Same as 4600 Series Narrow Stile Rim Device



### SPECIFICATIONS

#### Door Width:

- 36" (914 mm) field sizeable to 30" (762 mm) panic-rated door and 28" (711 mm) fire-rated door for devices with any monitoring switches
- 48" (1219 mm) field sizeable to 36" (914 mm) panic- or fire-rated door for devices with any monitoring switches
- 36" field sizeable to 34" door minimum for devices with motorized electric latch retraction or delayed egress
- 36" door minimum for devices with solenoid electric latch retraction, electric dogging, or alarm kit
- 48" field sizeable to 42" door minimum for devices with solenoid electric latch retraction, electric dogging or alarm kit
- 48" field sizeable to 40" door minimum with motorized electric latch retraction or delayed egress

### FUNCTIONS

- ELR - Electric Latch Retraction
- ED - Electric Dogging
- RX - Request to Exit (field installation kit 2-649-5001)
- RX2 - Dual Request to Exit
- ELRX - Electric Latch Retraction with Request to Exit
- EDRX - Electric Dogging with Request to Exit
- ALK - Alarm Kit (kit 4941, tamper switch 2-649-1090)
- LM - Latchbolt Monitor (2-649-0168)
- RXLM - Request to Exit with Latchbolt Monitor
- MLR - Motor Driven Electric Latch Retraction (field installation kit 2-649-5007)
- MLRX - Motor Driven Electric Latch Retraction with Request to Exit
- DE - Delayed Egress (must order with wall mount controller 2-679-0630 separately)

*Electrical Specifications and Wire Requirements - See 4600 Series Electric Modifications page 39.*





## 4600 SERIES - 4941 ALARM KIT

### WARRANTY

- One-year on electrified components
- Lifetime on hardware components



### SPECIFICATIONS

Battery:	<ul style="list-style-type: none"><li>• Standard 9-Volt battery required</li><li>• Audible chirp and alternating LED color flash when battery is low</li></ul>
Alarm:	100 decibel horn sounds immediately upon pressing push pad
Cylinder:	<ul style="list-style-type: none"><li>• 1-1/8" or 1-1/4" Mortise cylinders acceptable</li><li>• Hager standard cam required</li><li>• Cylinder sold separately</li></ul>
Activation:	<ul style="list-style-type: none"><li>• Alarm is armed by turning key clockwise</li><li>• Alarm is disarmed by turning the key counter-clockwise</li><li>• Alarm is turned to service mode by turning the key counter-clockwise twice</li></ul>
Alarm Timing:	<ul style="list-style-type: none"><li>• Alarm will sound for either 1, 3, 5 minutes or continuously</li><li>• Times are selectable by on board switches</li></ul>
Warning Decal:	"Emergency Exit Only – Alarm Will Sound" on push pad of exit device
Indicator:	<ul style="list-style-type: none"><li>• LED Indicator</li><li>• Red LED will illuminate intermittently when armed</li><li>• Green LED will illuminate when unarmed</li><li>• Blue LED will illuminate in service mode</li><li>• Alternate colors flash when battery is low</li></ul>
Options:	<ul style="list-style-type: none"><li>• Tamper Switch available that sounds alarm when end cap is removed</li><li>• Latch monitor switch is available that sounds alarm when latch is retracted without actuating the push pad</li><li>• Latch Monitor Switch typically used with Surface Vertical Rod devices</li><li>• When utilizing the latch monitor, the outside trim unit will also sound alarm</li></ul>
Output:	Alarm is equipped with output port





## 4600 SERIES - ELECTRIC MODIFICATIONS

FUNCTION	#	DESCRIPTION
Electric Latch Retraction - Solenoid	ELR	Provides the means of locking or unlocking exit devices remotely. Requires the use of Hager 2901 or 2902 power supply or warranty voided. <i>Note: Mortise Exits require Motor Driven Latch Retraction (MLR).</i>
Electric Dogging	ED	Provides continuous latch retraction and dogging simultaneously.
Request to Exit	RX	Used to shunt an alarm, activate an alarm, provide release of magnetic locks, or signal a console.
Electric Latch Retraction with Request to Exit	ELRX	Provides the means of locking or unlocking exit devices remotely, along with an SPDT switch. Requires the use of Hager 2901 or 2902 power supply or warranty voided. <i>Note: Mortise Exits will require Motor Driven Latch Retraction.</i>
Electric Dogging with Request to Exit	EDRX	Provides continuous latch retraction and dogging simultaneously along with an SPDT switch.
Dual Request to Exit	RX2	Features two SPDT switches
Latchbolt Monitoring	LM	An internal SPDT switch that monitors the latchbolt to signal both egress and access of an opening.
Latchbolt Monitoring/Request to Exit	RXLM	Two internal SPDT switches that monitor the latchbolt and the pushbar simultaneously.
Delayed Egress	DE	Delays egress for 15 or 30 seconds when unauthorized egress is initiated. Wall mount controller (2-679-0630) provides digital countdown display with verbal instructions or alarm tone only and must be ordered separately.
Motor Driven Electric Latch Retraction	MLR	Provides the means of locking or unlocking exit devices remotely using an electric motor. Recommend Hager 2903 or 2904 Power Supply.
Motor Driven Electric Latch Retraction with Request to Exit	MLRX	Provides the means of locking or unlocking exit devices remotely using an electric motor, along with an SPDT switch. Recommend Hager 2903 or 2904 Power Supply.

### ELECTRICAL SPECIFICATION/RATINGS AND WIRE REQUIREMENTS

Electrical Specifications/Ratings:

- ED; .225 AMP @ 24 Volt +/- 2V
- RX or LM; 125 VAC (3 AMP current); 30 VDC (2 AMP current)
- ELR; Requires 2901/2902 power supply
- MLR; 1 AMP in rush @ 24 VDC +/- 2V, 400 mA holding

Wire Requirements:

- Status switches (i.e. RX, LM, etc.) require 2 wires per switch to monitor a normally open (NO) or normally closed (NC) position
- All devices provide 3 wires per switch so both NO and NC positions can be monitored
- Monitoring both positions will require 3 wires per switch

### QUICK CONNECT

Available on ED, ELR, LM, MLR, and RX

### POWER SUPPLIES

PRODUCT #	DESCRIPTION
2901	For use with 4500/4600 Series electric latch retraction (ELR)
2902	For use with 4500/4600 Series electric latch retraction in a day/night mode of operation (ELR)
2903	Provides 24 Volt DC power for Fail Safe or Fail Secure locking devices and interface with building alarm controls, card readers, keypads, and other door controls
2904	Provides 24 Volt DC power and control for openings with an electrified locking device and automatic door operator
2908	Provides up to 1 amp of 12 or 24 Volt DC power - modular
2909	Provides up to 2 amps of 12 or 24 Volt DC power - modular

**ALARMED DEVICES - SPECIFY WHEN ORDERING:** (Note: Alarm kit components may be purchased separately)

**ALK - Alarm Kit**

**ALM - ALK with Latch Monitor Switch**

**ALT - ALK with Tamper Switch**

**ALL - ALK with Latch Monitor and Tamper Switch**





## 4600 SERIES - ESCUTCHEON TRIM

**WARRANTY** | Lifetime on hardware components

**SPECIFICATIONS**

Escutcheon: | 1-11/16" x 7-7/8" (43 mm x 200 mm)

**LEVERS** | Archer, August, William or Withnell Levers

**FINISHES** | US3, US4, US10, US10B, US26, US26D (Not Available in US32D)



**46BE**  
**Blank Escutcheon**  
 ANSI Function: 14 - Always operable (passage)



**46CE**  
**Cylinder Escutcheon**  
 ANSI Function: 08 - Key locks or unlocks lever  
 Cylinder: Requires 3902 mortise cylinder with 3976 L cam (sold separately)



**46DT**  
**Dummy Trim**  
 ANSI Function: 02 - Pull when device is dogged down



**46NK**  
**Night Lever**  
 ANSI Function: 09 - Key locks or unlocks lever. Lever is locked when key is removed.  
 Cylinder: Requires 3902 mortise cylinder, with 3976 L cam (sold separately)



**46NL**  
**Night Latch**  
 ANSI Function: 03 - Key retracts latchbolt  
 Cylinder: Requires 3901 rim cylinder with long tailpiece (sold separately)  
 Notes: Maximum door thickness compatibility is 2-1/2" (38 mm)



**RIM Cylinder by Optional Pull**  
 ANSI Function: 03 - Key retracts latchbolt  
 Finishes: US3, US4, US10, US10B, US26, US26D, US32D  
 Cylinder: Requires 3901 rim cylinder (sold separately). Standard (attached) and long tailpieces in every box.  
 Notes:
 

- For use with 4600 RIM
- For pull options see Trim & Auxiliary section





## 4600 SERIES - ESCUTCHEON TRIM - LEVER OPTIONS

**ARCHER LEVER**

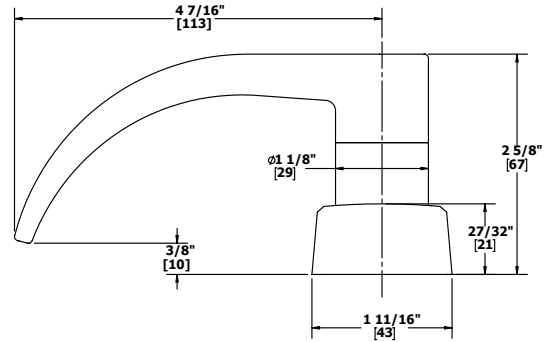

**AUGUST LEVER**

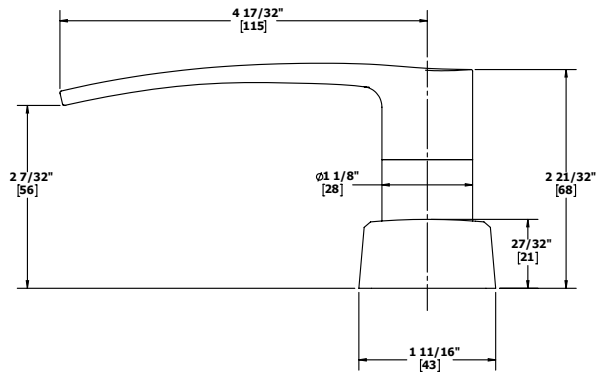

**WILLIAM LEVER**

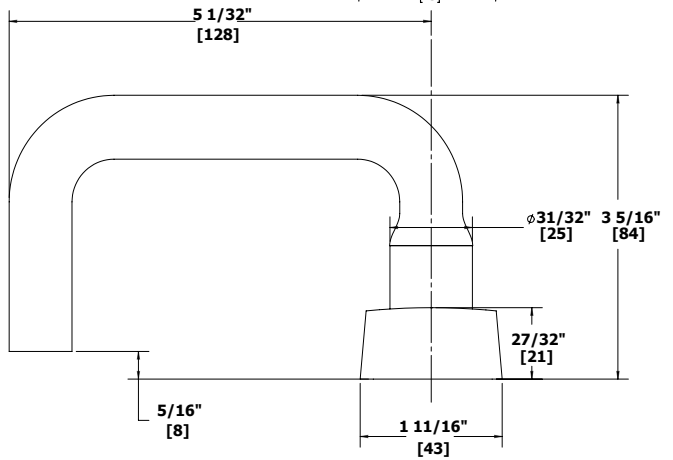

**WITHNELL LEVER**

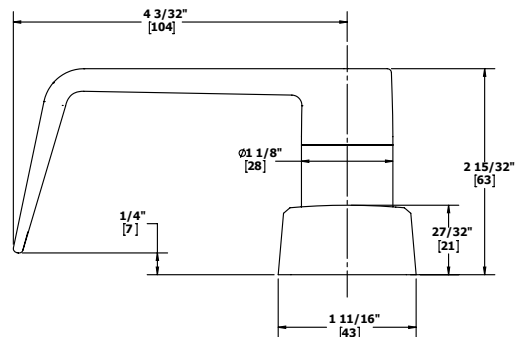



## 4600 SERIES - STRIKES

## 4600 SERIES - ACCESSORIES



### 4920

#### Strike

Optional strike to be used with 4600 Series Rim exit device; not for fire-rated doors

Finishes: US32D  
Notes: For standard surface mounted applications



### 4920F

#### Fire-rated Strike

Included standard with 4600 Series Fire-rated Rim exit device

Finishes: US32D  
Notes: For standard surface mounted applications



### 4950

#### Blade Stop Strike

Included standard with 4600 Series Rim exit device; not for fire-rated doors

Finishes: US32D



### 4951

#### Single Rabbit Strike

Optional strike to be used with 4600 Series Rim exit device; not for fire-rated doors

Finishes: US32D



### 4952

#### Semi-Flush Mount Strike

Optional strike to be used with 4600 Series Rim exit device; not for fire-rated doors

Finishes: US32D



### 2-649-0250/2-649-0257

#### Photoluminescent

Push bar cover option for 4500 & 4600 Series exit devices

Description: 2-649-0250 - 4500/4600 36"  
2-649-0275 - 4500/4600 48"  
Features: 

- Requires no wiring or maintenance
- Recharges with exposure to ambient light



### 4925R

#### Cylinder Dogging Conversion Kit

Finishes: US3, US4, US10, US10B, US26, US26D, US32D

Packaging: One (1) each dogging plate, cylinder collar, cash box nut

Notes: 

- Mortise cylinder 3902 with standard cam, sold separately
- Specify 36" (914 mm) or 48" (1219 mm)



### 4960R

#### Shim Kit

To be used with 4600 Series Rim exit device where a glass bead kit would interfere with exit device

Finishes: US3, US4, US10, US10B, US26, US26D, US32D

Packaging: Two (2) each 1/8" (3 mm) shims and appropriate fasteners



### 4965

#### Head Cover

For use with 4600 Series Rim exit device

Finishes: US3, US4, US10, US10B, US26, US26D, US32D

Packaging: One (1) head cover and four (4) each M4 x 6mm MS



#### Standard



#### Flush

### END CAPS

For use with all 4500 and 4600 Series exit devices

Packaging: One (1) each cap and bracket plus fasteners

Finishes:

	Standard	Flush
US3	(2-649-0038)	(2-649-0218)
US4	(2-649-0039)	(2-649-0220)
US10	(2-649-0040)	(2-649-0214)
US10B	(2-649-0041)	(2-649-0215)
US26	(2-649-0042)	(2-649-0216)
US26D	(2-649-0043)	(2-649-0217)
US32D	(2-649-0044)	(2-649-0219)



# 4700 Series

## STANDARD DUTY APPLICATION



The Hager 4700 Series is designed and engineered to provide superior performance on standard stile doors in a range of light commercial and standard duty applications. Properly applied and maintained Hager 4700 Series Exit Devices and Trim are backed by a five-year warranty. Go to [www.hagerco.com](http://www.hagerco.com) for specific warranty conditions.

Hager 4700 Series Exit Devices meet Life Safety codes and Fire Safety requirements. The 4700 Series Rim device meets the requirements for a Severe Windstorm Resistant Component.

Made with superior materials and with dead locking stainless steel Pullman type latchbolts, the 4700 Series Exit Devices provide necessary security and performance at economy pricing.





## 4700 SERIES - COMPLIANCE AND CERTIFICATIONS

### 4700 SERIES

UL305 Listed for Panic Hardware



UL10C Positive Pressure Rated



UL10B Neutral Pressure Rated



Complies with ANSI A117.1 for Accessible Buildings and Facilities



ANSI A 250.13 Severe Windstorm Resistant Component

RIM	SVR
YES	YES
YES	YES
YES	YES
YES	YES
YES	---

### 4700 SERIES FIRE-RATED DEVICES

UL/cUL Listed for "A" Label Door Up to and Including...

UL/cUL Listed for "B" Label Door Up to and Including...

Rim with Fire-rated Removable Mullion 4900UF  
UL/cUL Listed and Warnock Hersey Listed for  
"A" Label Door Up to and Including...



VR X VR SAME DIRECTION\*

UL/cUL Listed for "A" Label Door Up to and Including...

VR X VR Double Egress

UL/cUL Listed for "A" Label Door Up to and Including...

RIM F	SVR F
3 HR 4'X8'	---
---	90 MIN 4'X8'
3 HR 8'X8'	---
---	90 MIN 8'X8'
---	90 MIN 8'x8'

\*Currently, no door manufacturer offers a listing over 90 minutes with doors swinging same direction. Consult wood door manufacturers for current UL listings.





## 4700 SERIES - GENERAL INFORMATION

### Installation Made Easy

For the convenience of our customers, Hager Companies introduced several key features to the exit device market.

- Thru-bolts are included with every model. Wood and machine screws are also provided standard in every package.
- Slotted strikes speed up installation, allowing the installer to make easy adjustments to align the latch to the strike.
- Escutcheon trim is surface mounted with the locking mechanism built inside, reducing door preparation and installation time by requiring fewer holes in the door.

### Shim Kits

Shim kits are available for devices on doors with glass bead kits or other interfacing moldings. Each kit contains two 1/8" (3.2 mm) shims and the appropriate longer fasteners.

### Sizing

The exit device is cut for 36" (914 mm) and 48" (1219 mm) wide doors. For other door widths, cut exit device to appropriate length. Recommended overall length of exit device is equal to the door width minus four inches. The surface vertical rod devices are supplied for an 84" (2134 mm) opening standard, but can be ordered for a 96" (2438 mm) opening. Extension rods are available to accommodate openings taller than 96" (2438 mm) up to 120" (3048 mm).

Trim Functions	Part Number	Function Description	ANSI Number
Passage	47BE* 47BT 47KP	Always operable (*specify handing when ordering)	14
Classroom	47CE* 47KE	Key locks or unlocks lever (*specify handing when ordering)	08
Dummy	47DT* 47KD 47PD 47RD	Pull when device is dogged down (*specify handing when ordering)	02
Night Latch	47NL* 47KN 47PN 47RN	Key retracts latchbolt (*specify handing when ordering)	03
Cylinder Thumbpiece	47PT	Key locks or unlocks thumbpiece	05

### Applications

#### Single Door (Rim Device)

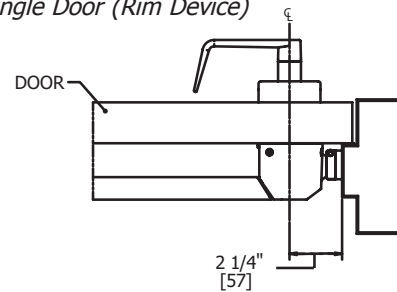

#### Double Door with Mullion (Rim x Rim)

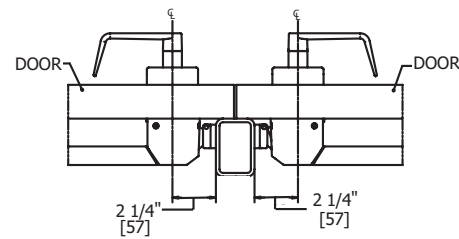

#### Double Door (SVR x SVR)

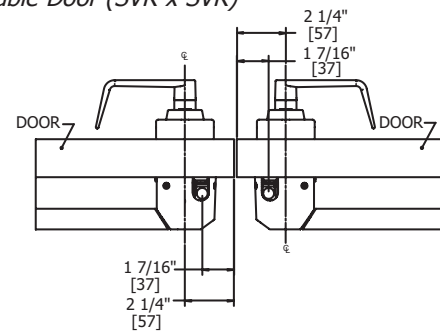

#### Double Door (SVR x Rim)

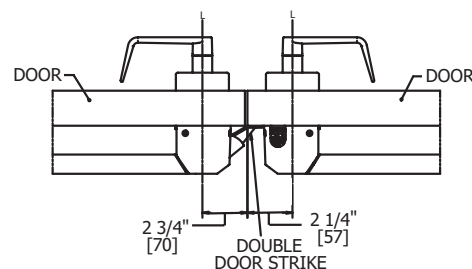





**4700 SERIES - DEVICE PROFILE**

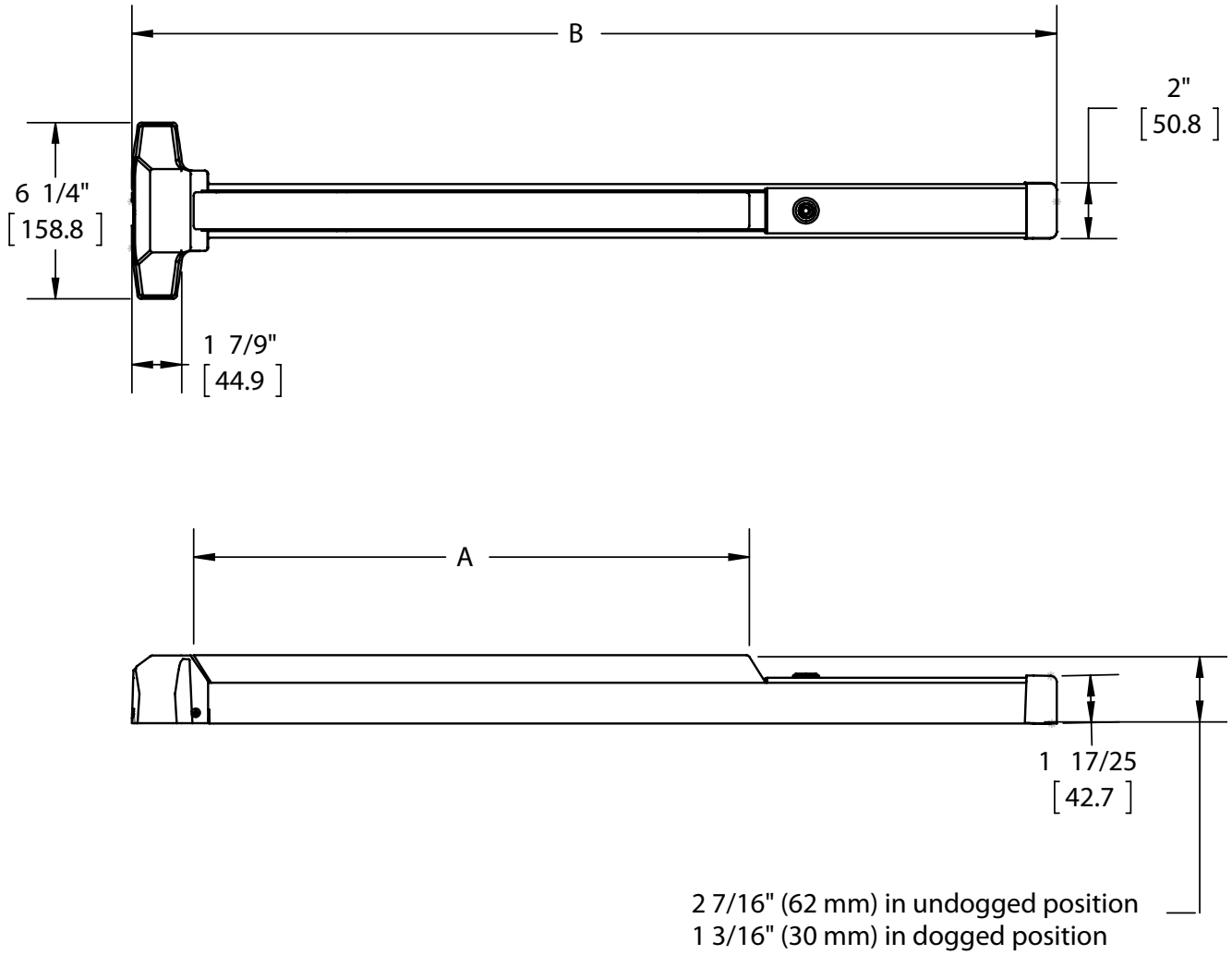

4700 SERIES	A	B
4700 PANIC - 36"	19 $\frac{45}{64}$ (500mm)	32 $\frac{51}{64}$ (833mm)
4700 FIRE - 36"		
4700 PANIC - 48"	24 $\frac{29}{64}$ (621mm)	44 $\frac{51}{64}$ (1137mm)
4700 FIRE - 48"		



## 4700 SERIES - HOW TO ORDER

### 4700 SERIES EXIT DEVICE

<b>4701</b>	<b>RIM</b>	<b>F</b>	<b>36"</b>	<b>US3</b>	<b>2"</b>
<b>Product Group</b>	<b>Type</b>	<b>Rating</b>	<b>Size</b>	<b>Finish</b>	<b>Door Thickness</b>
4700 Series, Standard Duty	RIM - Rim Device SVR - Surface Vertical Rod	F - Fire Rated O - Non-Fire Rated	36" 48" 36" x 84" 36" x 96" 48" x 84" 48" x 96"	US3 US32D ALM DBZ	1-5/8" 1-3/4" 2" 2-1/4"

### 4700 SERIES TRIM

<b>47</b>	<b>CE</b>	<b>RH</b>	<b>ARC</b>	<b>US3</b>	<b>2"</b>	<b>TW</b>
<b>Product Group</b>	<b>Trim/Function</b>	<b>Handing</b>	<b>Lever Style</b>	<b>Finish</b>	<b>Door Thickness</b>	<b>Options</b>
47 - 4700 Series, Standard Duty	CE - Cylinder Escutcheon BE - Blank Escutcheon NL - Night Latch DT - Dummy Trim KD - Key in Lever - Dummy Trim KE - Key in Lever - Entrance KN - Key in Lever - Night Latch KP - Key in Lever - Passage PD - Pull Plate Dummy Trim PN - Pull Plate Night Latch RD - Raised Lip Pull - Dummy Trim RN - Raised Lip Pull - Night Latch BT - Thumbpiece Pull Plate, Passage PT - Thumbpiece Pull Plate, Entrance	RH - Right Handed / LHR LH - Left Handed / RHR	ARC - Archer AUG - August WTN - Withnell APL - Apollo knob	US3 US32D ALM DBZ	1-5/8" 1-3/4" 2" 2-1/4"	TW - Tactile Warning A - Antimicrobial Coating

**Notes:**

1. Handing is required for the 4700 Series trim.
2. Cylinders sold separately.
3. For more cylinder information, please refer to Cylinder, Core & Keying in the Locks section of the catalog.
4. Maximum door thickness compatibility for key-in-lever (Entrance, Night Latch, and Passage) trim is 1-3/4" (44 mm)



## 4700 SERIES - STANDARD DUTY RIM DEVICE

### WARRANTY

Five-year warranty

### FEATURES

Certification:	Meets life safety codes and fire-safety requirements. See charts on page 44 for details and options.
Covers:	Cast brass, bronze, stainless steel, zinc
Cover Tube:	Painted steel, plated steel, stainless steel
Dogging:	Hex dogging feature standard on non-fire labeled doors
End Caps:	Painted steel, plated steel, stainless steel
Fasteners:	<ul style="list-style-type: none"> <li>• Wood and machine screws</li> <li>• Thru-bolts supplied standard</li> </ul>
Latchbolt:	3/4" (19 mm) throw, pullman type with automatic dead-latching, stainless steel
Strikes:	<ul style="list-style-type: none"> <li>• Stainless steel with stainless steel pin and roller - included standard with panic and fire-rated devices</li> <li>• Surface applied to frame with slotted holes for easy adjustment</li> <li>• Optional double door strike for use with surface vertical rod and rim devices</li> </ul>



### SPECIFICATIONS

Door Thickness:	1-3/4" (44 mm) - Standard
Door Width:	<ul style="list-style-type: none"> <li>• 36" (914 mm) field sizeable to 30" (762 mm) door</li> <li>• 48" (1219 mm) field sizeable to 36" (914 mm) door</li> </ul>
Projection:	<ul style="list-style-type: none"> <li>• 2-7/16" (62 mm) in undogged position</li> <li>• 1-3/16" (30 mm) in dogged position</li> </ul>
Stile Width:	<ul style="list-style-type: none"> <li>• 4-1/2" (114 mm) - minimum stile width required for single door and 5/8" (16 mm) stop</li> <li>• 4-1/2" (114 mm) - minimum stile width required for double door x surface vertical rod device with double door strike</li> <li>• 3-3/4" (95 mm) - minimum stile width required for double door x mullion x 4920 strike</li> <li>• 5" (127 mm) - minimum stile width required for double doors with 2" (51 mm) mullion</li> <li>• All stile widths are measured from door edge</li> </ul>
Notes:	<ul style="list-style-type: none"> <li>• Cylinders sold separately</li> <li>• Escutcheon and thumbpiece pull plate trim is handed</li> <li>• Apollo knob is not ADA compliant</li> <li>• Recommended for use on appropriately reinforced doors</li> </ul>

### TRIM

- 4700 Series escutcheon trim for rim device is available with a variety of lever options (p. 51)
- 4700 Series key-in-trim is available with a variety of lever options plus a knob option (p. 53)
- Pull plate trim
- Raised lip pull
- Rim cylinder x optional pull

### FINISHES

US3, US32D, ALM, DBZ





## 4700 SERIES - STANDARD DUTY SURFACE VERTICAL ROD DEVICE

<b>WARRANTY</b>	Five-year warranty
<b>FEATURES</b>	
Certification:	Meets life safety codes and fire-safety requirements. See charts on page 44 for details and options.
Covers:	Cast brass, bronze, stainless steel, zinc
Cover Tube:	Painted steel, plated steel, stainless steel
Dogging:	Hex dogging feature standard on non-fire labeled doors
End Caps:	Painted steel, plated steel, stainless steel
Fasteners:	<ul style="list-style-type: none"> <li>• Wood and machine screws</li> <li>• Thru-bolts supplied standard</li> </ul>
Latchbolt:	<ul style="list-style-type: none"> <li>• Top - 3/8" (9 mm) throw with automatic dead-latching, stainless steel</li> <li>• Bottom - 3/8" (9 mm) throw held retracted during door swing, stainless steel</li> </ul>
Strikes:	<ul style="list-style-type: none"> <li>• Stainless steel with stainless steel pin and roller - included standard with panic and fire-rated devices</li> <li>• Surface applied to frame with slotted holes for easy adjustment</li> <li>• Optional double door strike for use with surface vertical rod and rim devices</li> <li>• Optional threshold strike for use with saddle threshold</li> </ul>
<b>SPECIFICATIONS</b>	
Door Thickness:	1-3/4" (44 mm) - Standard
Door Width:	<ul style="list-style-type: none"> <li>• 36" (914 mm) field sizeable to 30" (762 mm) door</li> <li>• 48" (1219 mm) field sizeable to 36" (914 mm) door</li> </ul>
Projection:	<ul style="list-style-type: none"> <li>• 2-7/16" (62 mm) in undogged position</li> <li>• 1-3/16" (30 mm) in dogged position</li> </ul>
Vertical Rods:	<ul style="list-style-type: none"> <li>• Rods for 7' (2134 mm) doors - 35-1/4" (895 mm) top rod length</li> <li>• Rods for 8' (2438 mm) doors - 47-1/4" (1200 mm) top rod length</li> <li>• Extension rod kits available, 2' (610 mm) or 3' (914 mm) for doors over 7'</li> </ul>
Stile Width:	<ul style="list-style-type: none"> <li>• 4-1/2" (114 mm) - minimum stile width required for single door and 5/8" (16 mm) stop</li> <li>• 4" (102 mm) - minimum stile width required for double doors</li> <li>• 4-1/2" (114 mm) - minimum stile width required for double door x Rim device with double door strike</li> <li>• All stile widths are measured from door edge</li> </ul>
Notes:	<ul style="list-style-type: none"> <li>• Escutcheon and thumbpiece pull plate trim is handed</li> <li>• Apollo knob is not ADA compliant</li> <li>• Recommended for use on appropriately reinforced doors</li> </ul>
<b>TRIM</b>	<ul style="list-style-type: none"> <li>• 4700 Series escutcheon trim for vertical rod device is available with a variety of lever options (p. 51)</li> <li>• 4700 Series key-in-trim is available with a variety of lever options plus a knob option (p. 53)</li> <li>• Pull plate trim</li> <li>• Raised lip pull</li> <li>• Rim cylinder x optional pull</li> </ul>
<b>FINISHES</b>	US3, US32D, ALM, DBZ





## 4700 SERIES - ESCUTCHEON TRIM

**WARRANTY** | Five-year warranty

### SPECIFICATIONS

Escutcheon: 1-11/16" x 7-7/8" (43 mm x 200 mm)

Handing: Specify when ordering

Door Thickness: For doors thicker than 1-3/4" or when used with a shim kit, must specify total door thickness

**LEVERS** | Archer, August or Withnell Levers

**FINISHES** | ALM, DBZ, US3, US32D



**47BE**  
**Blank Escutcheon**  
 ANSI Function: 14 - Always operable (Passage)



**47CE**  
**Cylinder Escutcheon**  
 ANSI Function: 08 - Key locks or unlocks lever  
 Cylinder: Requires 3902 mortise cylinder with standard cam (sold separately)



**47DT**  
**Dummy Trim**  
 ANSI Function: 02 - Pull when device is dogged down



**47NL**  
**Night Latch**  
 ANSI Function: 03 - Key retracts latchbolt  
 Cylinder: Requires 3902 mortise cylinder with standard cam (sold separately)





**4700 SERIES - ESCUTCHEON TRIM - LEVER OPTIONS**

**ARCHER LEVER**

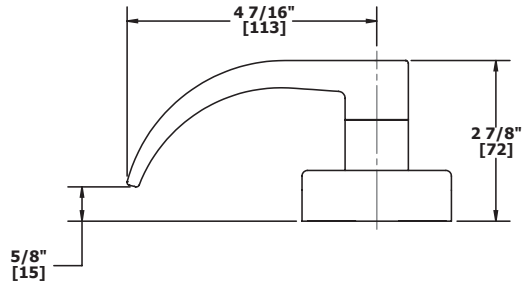

**AUGUST LEVER**

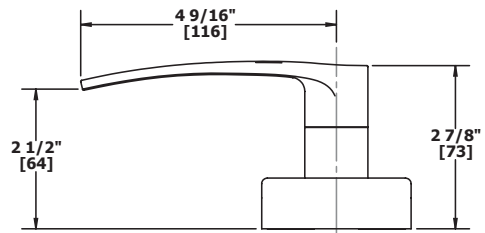

**WITHNELL LEVER**

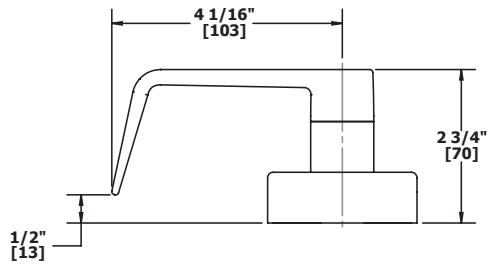



## 4700 SERIES - KEY-IN-LEVER TRIM

**WARRANTY** | Five-year warranty

**SPECIFICATIONS**

Rose Diameter: | 3-3/8" (86 mm)

Notes: | Apollo knob is not ADA compliant. Best used where accessibility is not an issue.

**LEVERS/KNOB** | Archer, August or Withnell Levers; Apollo Knob (47KE, 47KN, US32D only)

**FINISHES** | ALM, DBZ, US3, US32D



**47KD**

**Key-in-Lever Dummy Trim**

ANSI Function: 02 - Entrance by trim when actuating bar is locked down



**47KE**

**Key-in-Lever Entrance**

ANSI Function: 08 - Entrance by lever; key locks or unlocks lever

Cylinder: 

- Standard core, C keyway - Standard
- Small Format Interchangeable Core available. 3981 core sold separately.

Keys: Two (2) brass keys per lock



**47KN**

**Key-in-Lever Night Latch**

ANSI Function: 03 - Entrance by trim when latchbolt is released by key; key is removable when locked

Cylinder: 

- Standard core, C keyway - Standard
- Small Format Interchangeable Core available. 3981 core sold separately.

Keys: Two (2) brass keys per lock



**47KP**

**Key-in-Lever Passage**

ANSI Function: 14 - Entrance by trim when latchbolt is released by lever; always active, no cylinder





## 4700 SERIES - KEY-IN-LEVER TRIM - LEVER AND KNOB OPTIONS

**ARCHER LEVER**

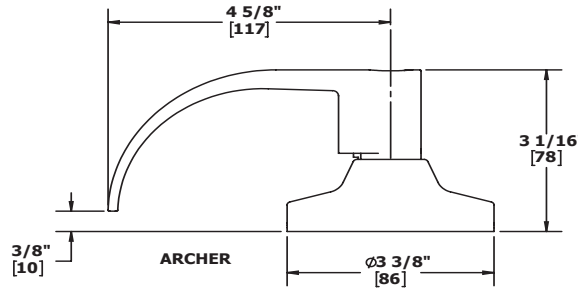

**AUGUST LEVER**

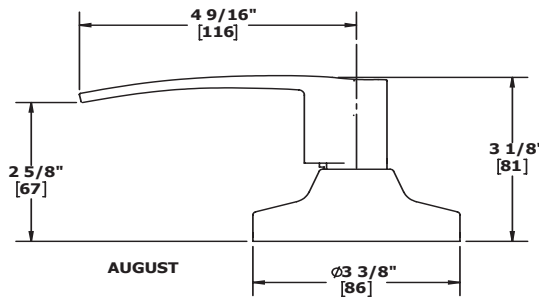

**WITHNELL LEVER**

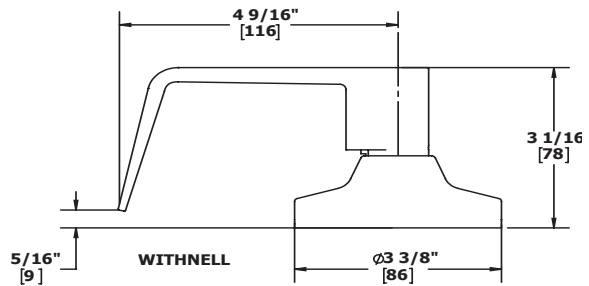

**APOLLO KNOB**

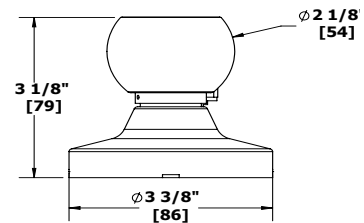





## 4700 SERIES - PULL PLATE TRIM

### SPECIFICATIONS

Escutcheon:	<ul style="list-style-type: none"> <li>• 47BT and 47PT - 3" x 14-5/8" (76 mm x 371 mm)</li> <li>• 47PD and 47PN - 3" x 11" (76 mm x 279 mm)</li> </ul>
Projection:	1-3/4" (44 mm)
Pull CTC:	5-1/2" (140 mm)

### FINISHES

- 47PD and 47PN - ALM, DBZ, US3, US32D
- 47BT and 47PT - US32D



#### **47PD Dummy Trim**

ANSI Function: 02 - Pull when device is dogged down



#### **47PN Night Latch**

ANSI Function: 03 - Key retracts latchbolt  
 Cylinder: Requires 3901 rim cylinder (sold separately)  
 Notes: Supplied with retaining cup for use with 161 door prep



#### **47BT Passage**

ANSI Function: 15 - Entrance by trim when latch is released by thumbpiece.  
 Thumbpiece is always active.  
 Handing: Specify when ordering



#### **47PT Entrance**

ANSI Function: 05 - Entrance by thumbpiece. Key locks or unlocks thumbpiece.  
 Cylinder: Requires 3902 mortise cylinder 1-1/8" to 1-3/8" with standard cam (sold separately)  
 Handing: Specify when ordering





## 4700 SERIES - RAISED LIP TRIM

### SPECIFICATIONS

Size: 3" x 7-3/4" (76 mm x 197 mm)  
 Projection: 1" (25 mm)

**FINISHES** | ALM, DBZ, US3, US32D



### 47RD

#### Raised Lip Pull Dummy

Function: 02 - Pull when device is dogged down



### 47RN

#### Raised Lip Pull Night Latch

Function: 03 - Key retracts latchbolt  
 Cylinder: Requires the use of a Rim cylinder, 3901, sold separately  
 Notes: Retaining cup, 2-649-0137, included for 161 door prep

## 4700 SERIES - STRIKES



### 4910

#### Strike

Included standard with 4700 Series Rim exit device  
 Finishes: US32D  
 Notes: For use with panic- or fire-rated doors



### 4911

#### Double Door Strike

Optional strike for use with 4700 Series Surface Vertical Rod and Rim exit device  
 Finishes: US32D  
 Notes: Not for fire-rated doors



### 4913

#### Top Strike

Included standard with 4700 Series Surface Vertical Rod exit device  
 Finishes: US32D  
 Notes: For use with panic- or fire-rated doors



### 4914

#### Bottom Strike

Included standard with 4700 Series Surface Vertical Rod exit device  
 Finishes: US32D  
 Notes: For use with panic- or fire-rated doors



### 4915

#### Threshold Strike

Optional strike for use with surface vertical rod exit device and saddle threshold.  
 Finishes: US32D  
 Notes: Not for fire-rated doors



## 4700 SERIES - ACCESSORIES



### 4917

#### Bottom Latch Assembly

For use with 4700 Surface Vertical Rod exit device; not for fire-rated doors  
 Finishes: US3, ALM, DBZ, US32D  
 Packaging: One (1) bottom latch with cover and appropriate fasteners



### 4917F

#### Bottom Latch Assembly

For use with 4700 Surface Vertical Rod exit device; for fire-rated doors  
 Finishes: US3, ALM, DBZ, US32D  
 Packaging: One (1) bottom latch with cover and appropriate fasteners



### 4918

#### Top Latch Assembly

For use with 4700 Surface Vertical Rod exit device  
 Finishes: US3, ALM, DBZ, US32D  
 Packaging: One (1) top latch with cover and appropriate fasteners



### 4919

#### Top or Bottom Rod Replacement Kit

For use with 4700 Surface Vertical Rod exit device  
 Finishes: US3, ALM, DBZ, US32D  
 Packaging: One (1) each 47-1/4" (1200 mm) rod, rod guide, rod connector assembly, and appropriate fasteners



### 4931R

#### Shim Kit

To be used with 4700 Rim exit devices where a glass bead kit or molding would interfere with exit device  
 Finishes: US3, ALM, DBZ, US32D  
 Packaging: Two (2) each 1/8" (3 mm) shims and appropriate fasteners



### 4931S

#### Shim Kits

To be used with 4700 Series Surface Vertical Rod exit devices where a glass bead kit or molding would interfere with exit device  
 Finishes: US3, ALM, DBZ, US32D  
 Packaging: Two (2) each 1/8" (3 mm) shims and appropriate fasteners



### 4933R

#### Head Cover

For use with 4700 Series Rim exit device  
 Finishes: US3, ALM, DBZ, US32D  
 Packaging: One (1) head cover with four (4) each M4 x 6 mm MS



### 4933S

#### Head Cover

For use with 4700 Series Surface Vertical Rod exit device  
 Finishes: US3, ALM, DBZ, US32D  
 Packaging: One (1) head cover with four (4) each M4 x 6 mm MS





## 4700 SERIES - ACCESSORIES



### 4934

#### Panic-Rated Dogging Plate

For use with 4700 Series exit devices

Finishes: US3, ALM, DBZ, US32D

Packaging: One (1) each dogging plate and hex key

Notes: Not for use on fire-rated device



### END CAP

For use with all 4700 Series exit devices

Packaging: One (1) each cap and bracket plus fasteners

Finishes:

ALM (2-649-0144)

DBZ (2-649-0145)

US3 (2-649-0146)

US32D (2-649-0147)



### 4934F

#### Fire-Rated Dogging Plate

For use with 4700 Series exit devices

Finishes: US3, ALM, DBZ, US32D

Packaging: One (1) each dogging plate



### 4936

#### 24" Extension Rod Kit

For use with 4700 Series Surface Vertical Rod exit device

Finishes: US3, ALM, DBZ, US32D

Packaging: One (1) each  
24" (610 mm) extension rod, rod connector, rod guide, plus wood and machine screws

Notes: Threaded on both ends; if cuts are required, cut the standard top rod on non-threaded end.



### 4937

#### 36" Extension Rod Kit

For use with 4700 Series Surface Vertical Rod exit device

Finishes: US3, ALM, DBZ, US32D

Packaging: One (1) each 36" (914 mm) extension rod, rod connector, rod guide, plus wood and machine screws

Notes: Threaded on both ends; if cuts are required, cut the standard top rod on non-threaded end.



# 4900 Series

## MULLIONS



Hager 4900 Series offers both a keyed removable mullion and a non-keyed removable mullion. Both are designed for use on double door openings with 4500, 4600 and 4700 Series Rim devices providing increased security and tighter closure, while providing easy adaptation for full width access. Our 4900 Series Mullions sets include a mullion tube, top and bottom brackets, and fasteners. Fire-rated mullions are UL listed for 3 hours on fire-rated pairs of doors up to 8 feet by 8 feet.





## 4900 SERIES - HOW TO ORDER

### 4900 SERIES MULLION SETS

**4900**



**Product Group**

4900 Series, Mullions

**U**



**Type**

- T - Keyed Removable Mullion
- U - Non-Keyed Removable Mullion

**F**



**Fire Rating**

- F - Fire Rated
- 0 - Non-Fire Rated

**84"**



**Size**

- 84"
- 96"
- 10' (120")

**USP**



**Finish**

USP

Notes:

1. Keyed removable mullion requires 3901 rim cylinder (sold separately).
2. Fire rated strike and hook kits sold separately (4912 for use with 4500 Series fire-rated exit device and mullion or 4916 for use with 4700 Series fire-rated exit device and mullion).
3. Stabilizer kit 4953 (sold separately).





## 4900 SERIES - KEYED REMOVABLE MULLION

**WARRANTY** | One-year warranty

### SPECIFICATIONS

Certification:	UL/cUL/Warnock Hersey listed for fire-rated doors up to 8' (2438 mm) x 8' (2438 mm)
Cylinders:	<ul style="list-style-type: none"> <li>• Solid brass 6-pin rim cylinders (3901, sold separately)</li> <li>• Standard core, C keyway - Standard</li> <li>• Small Format Interchangeable Core available (sold separately)</li> </ul>
Mullion:	2" x 3" (51 mm x 76 mm) – 11 gauge steel tube
Fasteners:	<ul style="list-style-type: none"> <li>• Four (4) 8 - 32 x 3/4" (19 mm) FPHMS</li> <li>• Four (4) 5/16" - 18 x 5/8" (16 mm) FPHMS</li> <li>• Two (2) 5/16" - 18 x 1-1/2" (38 mm) FPHMS</li> <li>• Two (2) 3/8" wedge anchors</li> </ul>
Shims:	<ul style="list-style-type: none"> <li>• 1/2" (13 mm) and 5/8" (16 mm) shims included (top)</li> <li>• 1/8" (4 mm) shims included (bottom)</li> </ul>
Strikes:	<ul style="list-style-type: none"> <li>• Panic-rated mullions use standard Rim strike supplied with exit device</li> <li>• Fire-rated strike and hook kit 4912 (4500 or 4600 Series) or 4916 (4700 Series) must be purchased separately</li> </ul>
Top Fitting:	<ul style="list-style-type: none"> <li>• Dead latch on fire-rated device</li> <li>• Latching head allows the mullion to be removed in seconds</li> <li>• Mullion can be locked in place without the use of a key</li> </ul>



**4900T/TF**

**FINISHES** | USP - grey primer only



#### **4900T Mullion Set**

Certification: Panic-rated  
 Opening Height: 84" (2134 mm),  
 96" (2438 mm),  
 120" (3048 mm)  
 Material: 11 gauge steel tube



#### **4900TF Fire-Rated Mullion Set**

Certification: UL fire-rated  
 Opening Height: 84" (2134 mm),  
 96" (2438 mm)  
 Material: 11 gauge steel tube





## 4900 SERIES - NON-KEYED REMOVABLE MULLION

**WARRANTY** | One-year warranty

**SPECIFICATIONS**

- Certification:** UL/cUL Listed for fire-rated pairs of doors up to 8' (2438 mm) X 8' (2438 mm)
- Mullion:**
- 2" x 3" (51 mm x 76 mm) – 11 gauge steel tube
  - Mullion easily removed by loosening top and bottom screws
- Fasteners:**
- Four (4) each 5/16" - 18 x 5/8" FHPMS (top bracket)
  - Two (2) each 5/16" - 18 x 1-1/2" FHPMS (top bracket)
  - Four (4) each 5/16" - 18 x 1-1/2" FHMS (bottom bracket)\*
  - Four (4) each 5/16" - 18 masonry anchors (5/8" diameter x 7/8" long) (bottom bracket)\*\*
  - Two (2) each 1/4" - 20 x 1-1/4" FHPMS (top fitting)
  - Two (2) each 1/4" - 20 thru bolts (top fitting)
  - Two (2) #10 - 24 x 3/8" FHPMS (top fitting)
  - One (1) 1/4 - 20 x 3/16" set screw (top fitting)
  - Fire-rated device - 5/16" - 18 x 1-1/4" FHMS, 5/16" - 18 masonry anchors (1/2" diameter x 1-1/2" long)
- Shims:**
- Two (2) each 1/2" (13 mm) and 5/8" (16 mm) shims included (top)
  - Two (2) 1/16" (1.6 mm) shims included (bottom)
- Strikes:**
- Panic-rated mullions use standard Rim strike supplied with exit device
  - Fire-rated strike and hook kit 4912 (4500 or 4600 Series) or 4916 (4700 Series) must be purchased separately



**4900U/UF**

**FINISHES** | USP - grey primer only



**4900U  
Non-Keyed Removable  
Mullion Set**

**Certification:** Panic-rated  
**Opening Height:** 84" (2134 mm),  
 96" (2438 mm),  
 120" (3048 mm)  
**Material:** 11 gauge steel tube



**4900UF  
Fire-Rated Non-Keyed Removable  
Mullion Set**

**Certification:** UL fire-rated\*  
**Opening Height:** 84" (2134 mm),  
 96" (2438 mm),  
**Material:** 11 gauge stainless steel tube



## 4900 SERIES - STRIKES AND STABILIZER KIT

## 4900T - ACCESSORIES



### 4912

#### Fire-Rated Strike and Hook Kit for 4500 and 4600 Series

Finishes: US32D  
 Notes: Must order for use with fire-rated mullion and fire-rated Rim devices to ensure fire rating



### 4902

#### Top/Bottom Bracket Set

Certification: Non-fire-rated  
 Function: Keyed Removable  
 Materials: Steel  
 Fasteners: Two (2) each MS #5/16 -18 x 1-1/2" FHP stainless; four (4) each MS #8-32 x 3/4" 100 degree FHP; four (4) each MS #5/16-18 x 5/8" FHP stainless zinc plated  
 Cylinder: Rim cylinder, 3901, sold separately



### 4916

#### Fire-Rated Strike and Hook Kit for 4700 Series

Finishes: US32D  
 Notes:
 

- Must order for use with fire-rated mullion and fire-rated Rim devices to ensure fire rating
- For use with 4900NKR mullion only



### 4902F

#### Fire-Rated Top/Bottom Bracket Set

Certification: Fire-rated  
 Function: Keyed removable  
 Materials: Steel  
 Fasteners: Two (2) each MS #5/16 - 18 x 1-1/2" FHP stainless; four (4) each MS #10 x 1" Type A FHP undercut stainless; four (4) each MS 10 - 24 x 5/8" FHP undercut stainless; four (4) each MS #5/16 - 18 x 5/8" FHP stainless zinc plated  
 Cylinder: Rim cylinder, 3901, sold separately



### 4953

#### Mullion Stabilizer Kit

Finishes: US32D  
 Notes: For use with mullion and exit devices for added security

## 4900T - CYLINDER



### 3901

#### Rim Cylinder

Conventional cylinder and Small Format Interchangeable Core sold separately. For more cylinder information, please refer to Cylinder, Core & Keying in the Lock section of this catalog.



### 4907

#### Mullion Tube

Certification: Fire-rated up to 96" (2438 mm)  
 Opening Height: 84" (2134 mm), 96" (2438 mm), 120" (3048 mm)  
 Finishes: USP grey primer  
 Materials: Steel



**4900 SERIES - 4900U ACCESSORIES**



**4904**

**Top/Bottom Bracket Set**

Certification: Non-fire-rated  
Function: Non-keyed removable  
Materials: Steel



**4904F**

**Fire-Rated Top/Bottom Bracket Set**

Certification: Fire-rated  
Function: Non-keyed removable  
Materials: Steel



**4905**

**Mullion Tube**

Certification: Fire-rated  
Opening Height: • 84" (2134 mm)  
• 96" (2438 mm)  
• 120" (3048 mm)  
Finishes: USP grey primer  
Materials: Steel  
Notes: 120" (3048 mm) not fire-rated





**One Family. One Brand. One Vision.™**

[www.hagerco.com](http://www.hagerco.com)



**One Family. One Brand. One Vision.™**

[www.hagerco.com](http://www.hagerco.com)

# Locks



Hager Companies offers a wide range of Grade 1 and Grade 2 products to meet almost any application and specification requirements. Hager locks are manufactured to the highest quality standards and extensively tested to ANSI standards and BHMA certification requirements. In addition, all leversets comply with ADA requirements outlined in ANSI A117.1.

## Table of Contents

2300 Series Tubular .....	3
2500 Series Cylindrical .....	9
3100 Series Deadlock .....	17
3200 Series Deadlock .....	21
3400 Series Cylindrical .....	25
3500 Series Cylindrical .....	35
3600 Series Tubular .....	43
3700 Series Interconnected .....	49
3800 Series Mortise .....	55
Cylinder, Core & Keying .....	73





# 2300 Series



Hager 2300 Series tubular lockset provides the necessary security and dependability for applications where there is a need for interior functions requiring a residential look and feel. It is well suited for light duty residential interior applications such as multi-family housing. It is offered in many of the popular designs that are seen throughout the industry today.











## 2300 SERIES - HOW TO ORDER

<p><b>2310</b></p> <p><b>Function</b></p> <ul style="list-style-type: none"> <li>10 - Passage</li> <li>17 - Single Dummy</li> <li>27 - Double Dummy</li> <li>40 - Privacy</li> </ul> <p><b>Product Group</b></p> <p>- Tubular, DECO</p>	<p><b>2<sup>3</sup>/<sub>4</sub>"</b></p> <p><b>Backset/Faceplate</b></p> <ul style="list-style-type: none"> <li>2-3/4" (70 mm)</li> <li>2-3/8" (60 mm)</li> </ul>	<p><b>US15</b></p> <p><b>Finish</b></p> <ul style="list-style-type: none"> <li>US3</li> <li>US15</li> <li>US10B</li> <li>US26</li> <li>US26D</li> </ul>	<p><b>US26D</b></p> <p><b>Interior Finish</b> (if different)</p>	<p><b>CHA</b></p> <p><b>Lever Style</b></p> <ul style="list-style-type: none"> <li>CHA - Charles Lever</li> <li>*JHN - Johnston Lever</li> <li>JOS - Joshua Lever</li> <li>LOU - Louis Lever</li> <li>*WRN - Warren Lever</li> </ul>	<p><b>ASA</b></p> <p><b>Strike</b></p> <ul style="list-style-type: none"> <li>ASA</li> <li>TEE</li> <li>FLRC and FULL (Default)</li> </ul>
---	--	---	--	--	--

\* Handing required for Johnston and Warren levers when specifying single dummy function.

Note:  
Finishes other than US10B, US15, and US26D are subject to longer lead times.

### 2300 SERIES FUNCTION CHART

Function	Function No.	Function Description	ANSI No.	
Non-Keyed				
	Passage	10	Latchbolt operated by lever from either side at all times.	-
	Dummy - Single	17	Pull one side, no mechanical operation.	-
	Dummy - Double	27	Pull both sides, no mechanical operation (back to back).	-
	Privacy	40	Latchbolt operated by lever from either side. Outside lever is locked by push button and unlocked by emergency release outside or operating inside lever.	-





## 2300 SERIES - LEVER OPTIONS

### CHARLES LEVER

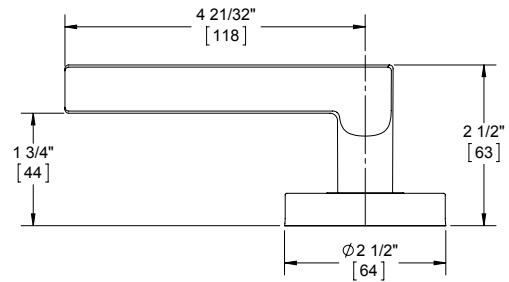

### JOHNSTON LEVER

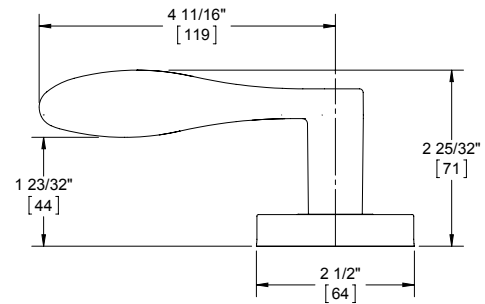

### JOSHUA LEVER

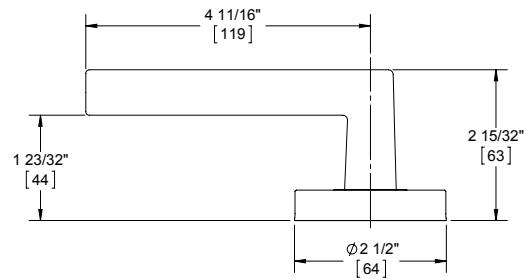

### LOUIS LEVER

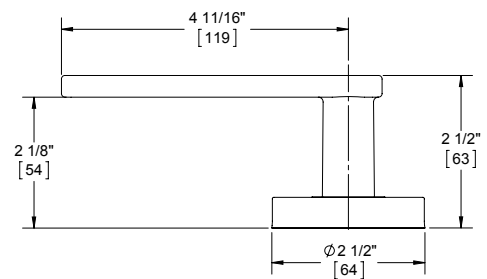

### WARREN LEVER

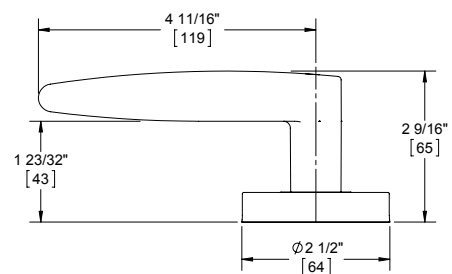



## 2300 SERIES - DECO TUBULAR - LIGHT DUTY RESIDENTIAL - MULTI FAMILY

<b>WARRANTY</b>	Five-year warranty
<b>FEATURES</b>	<ul style="list-style-type: none"> <li>• ADA Compliant</li> <li>• No exposed mounting screws</li> </ul>
Lever Options:	Charles, Johnston, Joshua, Louis, and Warren
Options:	Split finish available
<b>SPECIFICATIONS</b>	
Exposed Trim:	<ul style="list-style-type: none"> <li>• Levers: Solid cast zinc (4.69" / 119 mm length)</li> <li>• Rose: Stainless steel (2.5" / 63.5 mm diameter)</li> </ul>
Door Thickness:	1-3/8" - 1-3/4" (35 mm - 45 mm)
Rose Diameter:	2-1/2" (63.5 mm)
Backset:	<ul style="list-style-type: none"> <li>• 2-3/4" (70 mm) - Standard</li> <li>• 2-3/8" (60 mm) - Optional</li> </ul>
Latchbolt:	<ul style="list-style-type: none"> <li>• 7/16" (11 mm) throw</li> <li>• 1" x 2-1/4" (25 mm x 57 mm) faceplate</li> <li>• Square and round corner faceplates come standard</li> </ul>
Strike:	Square and round corner full lip strikes come standard
Door Handing:	Non-handed (except for Johnston and Warren, 17 Functions)
Functions:	10 Passage, 17 Dummy, 27 Back to Back Dummy, 40 Privacy
<b>FINISHES</b>	US3, US10B, US15, US26, US26D





## 2300 SERIES LATCHBOLTS

## 2300 SERIES ADDITIONAL STRIKES



- 2-639-7607**  
**2-3/4" Backset Passage Latch**
- Square and round corner standard
  - 1" x 2-1/4" (25 mm x 57 mm) faceplate
  - For use with passage function



- 2-639-7608**  
**2-3/4" Backset Privacy Latch**
- Square and round corner standard
  - 1" x 2-1/4" (25 mm x 57 mm) faceplate
  - For use with privacy function



- 2-639-7609**  
**2-3/8" Backset Passage Latch**
- Square and round corner standard
  - 1" x 2-1/4" (25 mm x 57 mm) faceplate
  - For use with passage function



- 2-639-7610**  
**2-3/8" Backset Privacy Latch**
- Square and round corner standard
  - 1" x 2-1/4" (25 mm x 57 mm) faceplate
  - For use with privacy function



- 3933**  
**T-Strike with Plastic Dust Box**
- 1-1/8" x 2-3/4" (29 mm x 70 mm)
  - Dust box included



- 3935**  
**Standard ASA Strike Plate**
- 1-1/4" x 4-7/8" (32 mm x 124 mm)
  - 1-5/16" lip
  - Other lengths available upon request



- 3959**  
**Faceplate Adapter**
- Converts 1" (25 mm) to 1-1/8" (28 mm) width



# 2500 Series



Hager 2500 Series Grade 2 lock is a perfect combination of value and performance and is the ideal choice of lock for typical commercial applications. The inherent value of this lock and the product offering make our 2500 Series lock a perfect choice for a stocking program. As an economical alternative to other Grade 2 cylindrical locks, it offers both dependability and affordability.





**2500 SERIES - HOW TO ORDER**

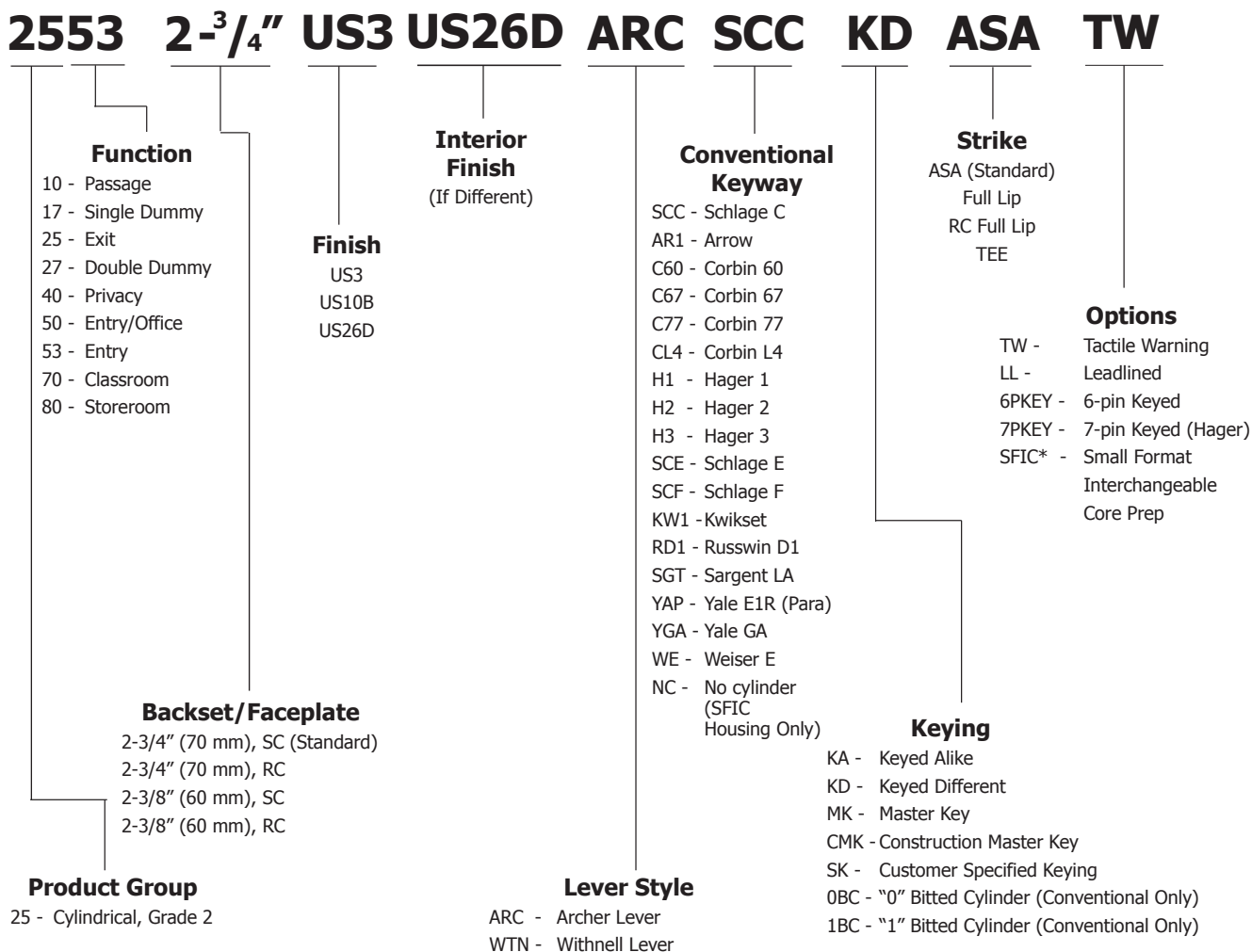

**Notes:**

1. If masterkeyed, include completed master key form with order (available on page 88 or [www.hagerco.com](http://www.hagerco.com)).
2. For additional keying information, please refer to cylinder, core, and keying section of catalog (page 73).









\* Small format interchangeable core sold separately. Available in Best Keyways (A Standard), or Hager Keyways (optional).

**Ordering example: 2553 2-3/4" US26D WTN NC ASA SFIC**





## 2500 SERIES - FUNCTION CHART

	Function	Function No.	Function Description	ANSI No.
<b>Non-Keyed</b>				
	Passage	10	Latchbolt operated by lever from either side at all times.	F75
	Dummy - Single	17	Pull one side, no mechanical operation.	-
	Exit	25	Blank plate outside (13/16" [31 mm] projection). Inside lever is always unlocked.	F111
	Dummy - Double	27	Pull both sides. No mechanical operation (back to back).	-
	Privacy	40	Latchbolt operated by lever from either side. Outside lever is locked by push button inside and unlocked by emergency release outside, operating inside lever or closing door.	F76A
<b>Keyed</b>				
	Entry/Office	50	Deadlocking latchbolt operated by lever from either side except when outside lever is locked by push button on inside lever. When outside lever is locked, operating key in outside lever or operating inside lever unlocks push button or other locking device and retracts latchbolt. Closing door does not release push button.	F82A
	Entry	53	Deadlocking latchbolt by lever either side, except when turn button inside locks outside lever. Pushing turn button in locks outside lever, requiring use of key outside to unlock. Turning inside lever unlocks outside lever. Pushing in and turning button locks outside lever, requiring key at all times. Turning inside lever does not unlock outside lever until button is manually turned to unlocked position. Inside lever always free.	F109
	Classroom	70	Deadlocking latchbolt operated by lever from either side except when outside lever is locked from outside by key. When outside lever is locked, latchbolt is operated by inside lever.	F84
	Storeroom	80	Deadlocking latchbolt operated by key in outside lever, or by operating inside lever. Outside lever is always locked. Inside lever is always unlocked.	F86





**2500 SERIES - LEVER OPTIONS**

**ARCHER LEVER**

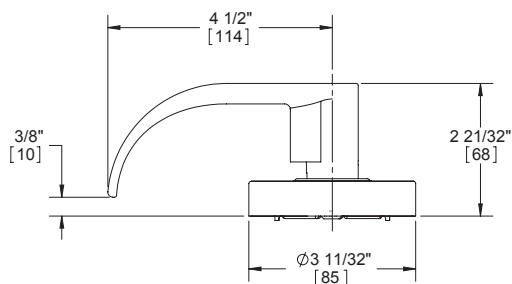

**WITHNELL LEVER**

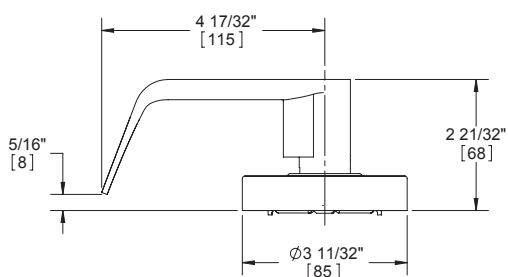

Optional tactile warning available on all lever styles (only outside lever will include raised surfaces unless otherwise specified).





## 2500 SERIES - GRADE 2 CYLINDRICAL - STANDARD DUTY COMMERCIAL

<b>WARRANTY</b>	One-year warranty
<b>FEATURES</b>	<ul style="list-style-type: none"> <li>• No exposed mounting screws</li> <li>• Non-handed</li> <li>• Conventional cylinder and small format interchangeable core option available</li> </ul>
Applications:	<ul style="list-style-type: none"> <li>• Standard duty commercial</li> <li>• Standard door prep - 2-1/8" (54 mm) diameter (bore)</li> <li>• Latch hole - 1" (25.4 mm) diameter (cross bore)</li> </ul>
Certifications:	<ul style="list-style-type: none"> <li>• Meets BHMA ANSI A156.2, Series 4000, Grade 2</li> <li>• ADA Compliant ANSI A117.1 Accessibility Code</li> <li>• UL/cUL Listed for all functions up to 3 hours "A" label single doors</li> <li>• UL 10C Positive Pressure Related</li> <li>• UL 10B Neutral Pressure Rated</li> </ul>
Lever Options:	Archer, Withnell levers
Options:	<ul style="list-style-type: none"> <li>• Lead lined</li> <li>• Tactile warning</li> </ul>
<b>SPECIFICATIONS</b>	
Exposed Trim:	<ul style="list-style-type: none"> <li>• Wrought brass, bronze, and stainless steel</li> <li>• Lever is zinc based, plated to match BHMA symbols</li> </ul>
Rose Diameter:	3-11/32" (85 mm)
Lock Chassis:	<ul style="list-style-type: none"> <li>• Heavy gauge steel, zinc dichromated for corrosion resistance</li> <li>• "Non-clutching" exterior lever on keyed functions</li> <li>• Removable thru-bolts</li> <li>• Failure to install thru-bolts and removable screw posts voids BHMA certification, UL rating, and warranty</li> </ul>
Keys:	Two operating keys supplied per lock
Cylinders/Cores:	<ul style="list-style-type: none"> <li>• Brass, keyed different, Schlage C keyway standard</li> <li>• Cylinder drilled 6-pin, keyed 5-pin</li> <li>• Other keying options, including keyed 6-pin, available from the factory (see cylinders, cores and keying sections).</li> <li>• Small Format Interchangeable Core option available</li> <li>• SFIC uncombined or combined, brass 6- or 7-pin cores sold separately</li> </ul>
Door Thickness:	1-3/8" - 2" (35 mm - 51 mm)
Backset:	<ul style="list-style-type: none"> <li>• 2-3/4" (70 mm) - Standard</li> <li>• 2-3/8" (60 mm) - Optional</li> </ul>
Latchbolt:	<ul style="list-style-type: none"> <li>• 1/2" (13 mm) throw, stainless steel</li> <li>• 1-1/8" x 2-1/4" (29 mm x 57 mm) faceplate for 2-3/4" (70 mm) backset</li> <li>• 1" x 2-1/4" (25 mm x 57 mm) faceplate for 2-3/8" (60 mm) backset</li> <li>• Deadlocking latchbolt prevents manipulation when door is closed; keyed functions and 25 function only</li> </ul>
Strike:	<ul style="list-style-type: none"> <li>• 3935 ASA 1-1/4" x 4-7/8" (32 mm x 124 mm) strike standard</li> <li>• Optional strikes available</li> </ul>
Functions:	10 Passage, 17 Dummy, 25 Exit Only, 27 Back to Back Dummy, 40 Privacy, 50 Entry/Office, 53 Entry, 70 Classroom, 80 Storeroom
Notes:	Blank plate projection is 13/16" (21 mm) for function 25
<b>FINISHES</b>	US3, US10B, US26D





## 2500 SERIES - LATCHBOLTS

### Spring Latches



**3947**  
**2-3/4" (70 mm) Backset**  
**Passage Spring Latch**  
• Square and round corner available  
• 1-1/8" x 2-1/4" (29 mm x 57 mm) faceplate

**3949**  
**2-3/8" (60 mm) Backset**  
**Passage Spring Latch**  
• Square and round corner available  
• 1" x 2-1/4" (25 mm x 57 mm) faceplate



**3965**  
**2-3/4" (70 mm) Backset**  
**Privacy Spring Latch**  
• Square and round corner available  
• 1-1/8" x 2-1/4" (29 mm x 57 mm) faceplate

**3967**  
**2-3/8" (60 mm) Backset**  
**Privacy Spring Latch**  
• Square and round corner available  
• 1" x 2-1/4" (25 mm x 57 mm) faceplate

### Dead Latches



**3948**  
**2-3/4" (70 mm) Backset**  
**Dead Latch**  
• Square and round corner available  
• 1-1/8" x 2-1/4" (29 mm x 57 mm) faceplate

**3950**  
**2-3/8" (60 mm) Backset**  
**Dead Latch**  
• Square and round corner available  
• 1" x 2-1/4" (25 mm x 57 mm) faceplate

### Optional Drive-In Spring Latches



**3922**  
**2-3/4" (70 mm) Backset**  
**Passage Spring Latch**

**3925**  
**2-3/8" (60 mm) Backset**  
**Passage Spring Latch**



**3923**  
**2-3/4" (70 mm) Backset**  
**Privacy Spring Latch**

**3926**  
**2-3/8" (60 mm) Backset**  
**Privacy Spring Latch**

### Optional Drive-In Dead Latches



**3924**  
**2-3/4" (70 mm) Backset**  
**Dead Latch**

**3927**  
**2-3/8" (60 mm) Backset**  
**Dead Latch**

### Backset Extension Links

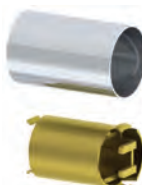

**3917**  
**3-3/4" (95 mm) Backset**  
**Extension Link**  
For use with 2-3/8" (60 mm) backset latch to achieve 3-3/4" total backset

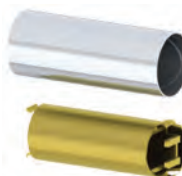

**3937**  
**5" (127 mm) Backset**  
**Extension Link**  
For use with 2-3/4" (70 mm) backset latch to achieve 5" total backset





## 2500 SERIES - STRIKES

## 2500 SERIES ACCESSORIES



**3933**  
**T-Strike with Plastic Dust Box**  
1-1/8" x 2-3/4" (29 mm x 70 mm)



**3911**  
**Thru-Bolt Jig**



**3934**  
**Full Lip Strike**  
1-5/8" x 2-1/4" (41 mm x 57 mm)



**3935**  
**ASA Strike Plate - Standard**

- 1-1/4" x 4-7/8" (32 mm x 124 mm)
- 1-5/16" lip
- Other lengths available upon request



**3958**  
**Full Lip Strike with Round Corner**

- 1-5/8" x 2-1/4" (41 mm x 57 mm)
- 1/4" (6 mm) radius



**3959**  
**Faceplate Adapter**  
Converts 1" (25 mm) to 1-1/8" (28 mm) width



# 3100 Series

 **HAGER**  
COMPANIES



Hager 3100 Series Grade 1 deadbolt is designed and engineered to withstand the most abusive environments. It is the perfect complement to Hager 3400 Series lockset for extra protection against break-in and is backed by a lifetime warranty.

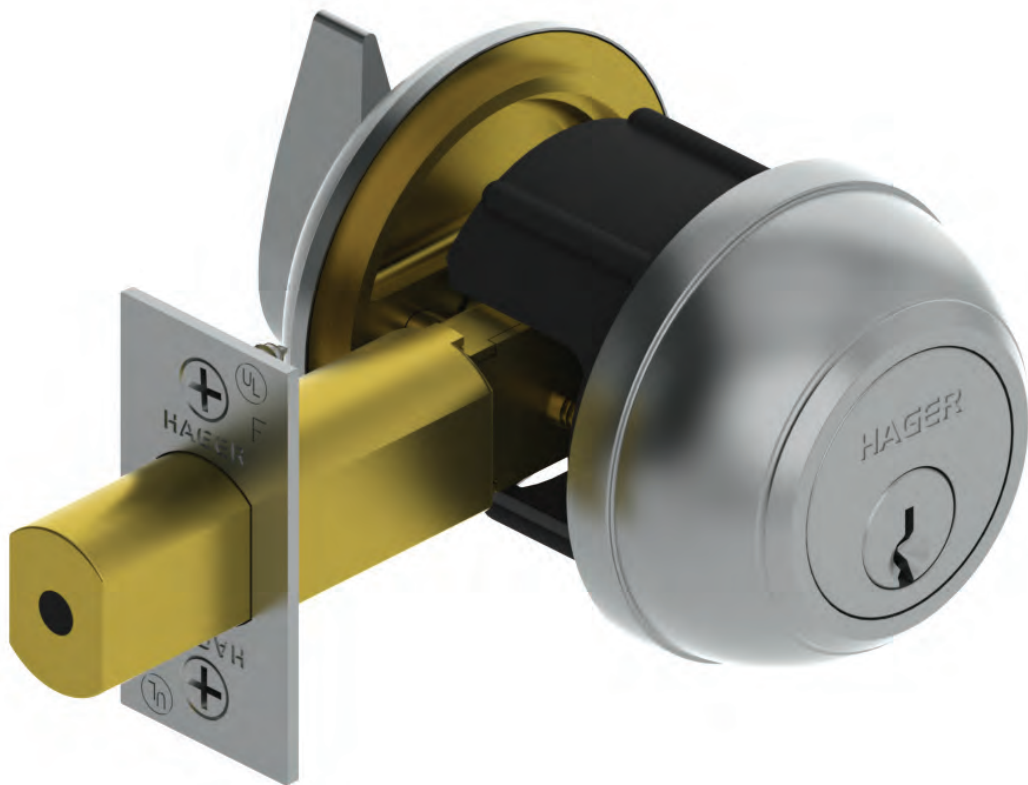



**3100 SERIES - HOW TO ORDER**

**3114 2-3/4" US26D US26 SCC KD ASA 6PKEY**

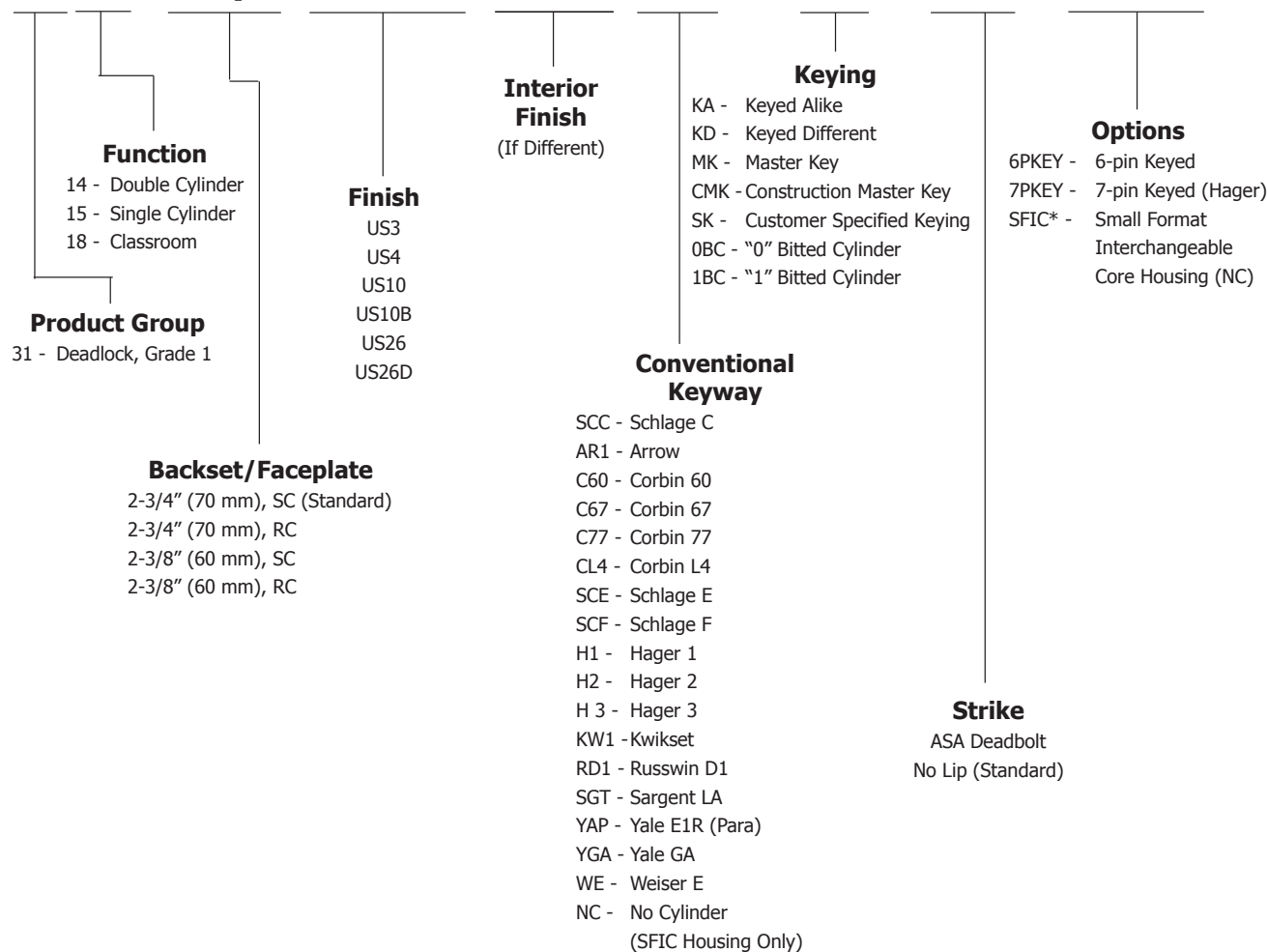



**Notes:**

1. If masterkeyed, include completed master key form with order (available on page 88 or www.hagerco.com).
2. For additional keying information, please refer to cylinder, core, and keying section of catalog (page 73).

\* Small format interchangeable core sold separately. Available in Best Keyways (A Standard), or Hager Keyways (optional).

**Ordering example: 3114 2-3/4" US26D NC SFIC**

**3100 SERIES FUNCTION CHART**

Function	Function No.	Function Description	ANSI No.
 Double Cylinder	14	Deadbolt thrown or retracted by key from either side. Bolt automatically deadlocks when fully thrown.	E2141
 Cylinder x Thumbturn	15	Deadbolt thrown or retracted by key from outside or by inside thumbturn. Bolt automatically deadlocks when fully thrown.	E2151
 Classroom	18	Deadbolt thrown or retracted by key outside. Inside thumbturn will retract bolt only. Bolt automatically deadlocks when fully thrown.	E2171





## 3100 SERIES - GRADE 1 DEADLOCK - AUXILIARY

<b>WARRANTY</b>	Lifetime warranty
<b>FEATURES</b>	<ul style="list-style-type: none"> <li>• Non-handed</li> <li>• Conventional cylinder or Small Format Interchangeable Core option available</li> </ul>
Certifications:	<ul style="list-style-type: none"> <li>• BHMA Certified ANSI A156.5 Grade 1</li> <li>• ANSI A250.13 Severe Windstorm Resistant Component</li> <li>• UL/cUL Listed for all functions up to 3 hours for "A" label single doors</li> <li>• UL10C Positive Pressure Rated</li> <li>• UL10B Neutral Pressure Rated</li> <li>• ADA - Thumbturn</li> </ul>
Options:	<ul style="list-style-type: none"> <li>• Split finish</li> <li>• Additional deadbolts and strikes available</li> </ul>

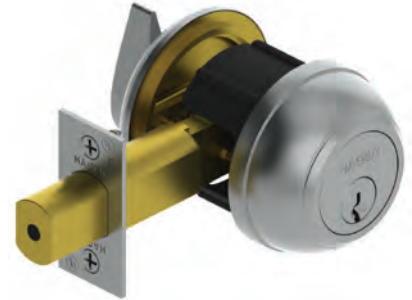

### SPECIFICATIONS

Standard Door Prep:	<ul style="list-style-type: none"> <li>• Cylinder hole: 2-1/8" (54 mm) diameter (bore)</li> <li>• Latch hole: 1" (25 mm) diameter (coss bore)</li> </ul>
Exposed Trim:	Wrought brass or bronze
Mechanism:	Steel, zinc dichromate plating
Keys:	Two operating keys supplied per lock
Cylinders/Cores:	<ul style="list-style-type: none"> <li>• Brass - Keyed Different - Schlage C Keyway standard</li> <li>• Cylinder drilled 6-pin, Keyed 5-pin - Standard</li> <li>• Other keying options, including keyed 6-pin, available from the factory (see Cylinder, Core and Keying section)</li> <li>• Small Format Interchangeable Core option available</li> <li>• SFIC uncombined or combined, brass 6- or 7-pin cores sold separately</li> </ul>
Door Thickness:	<ul style="list-style-type: none"> <li>• 1-3/4" - 2" (45 mm - 51 mm) - Standard</li> <li>• 2-1/4" (57 mm) available for conventional cylinder only - Must specify</li> </ul>
Backset:	<ul style="list-style-type: none"> <li>• 2-3/4" (70 mm) - Standard</li> <li>• 2-3/8" (60 mm) - Optional</li> </ul>
Latchbolt:	<ul style="list-style-type: none"> <li>• 1" (25 mm) Throw - Brass with concealed hardened steel roller to prevent sawing or cutting</li> <li>• 1-1/8" x 2-1/4" (29 mm x 57 mm) Square Corner Faceplate</li> </ul>
Strikes:	<ul style="list-style-type: none"> <li>• 3930 Square Corner, 1-1/8" x 2-3/4" (29 mm x 70 mm) with dustbox - Standard</li> <li>• 3929 ASA Deadbolt Strike - Optional</li> </ul>
Functions:	14 Double Cylinder, 15 Cylinder x Thumbturn, 18 Classroom

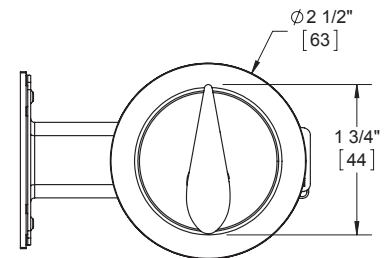
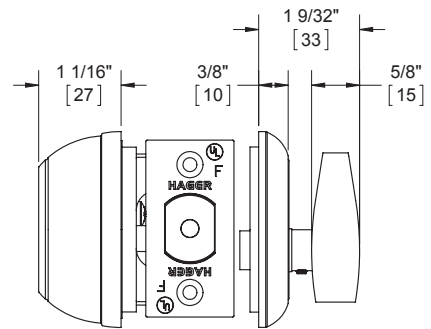

<b>FINISHES</b>	US3, US4, US10, US10B, US26, US26D
-----------------	------------------------------------





## 3100 SERIES LATCHBOLTS



**3940**  
**2-3/4" (70 mm) Backset Latchbolt - Standard**

- Square and round corner available
- 1-1/8" x 2-1/4" (29 mm x 57 mm) faceplate
- Round corner not available in US32/32D

**3941**  
**2-3/8" (60 mm) Backset Latchbolt - Optional**

- Square and round corner available
- 1" x 2-1/4" (25 mm x 57 mm) faceplate
- Round corner not available in US32/32D

## 3100 SERIES STRIKES



**3929**  
**ASA Deadbolt Strike - Optional**  
1-1/4" x 4-7/8" (32 mm x 124 mm)



**3930**  
**Strike Plate - Standard**  
• 1-1/8" x 2-3/4" (29 mm x 70 mm)  
• Dust box included



# 3200 Series



Hager 3200 Series Grade 2 deadlock provides a perfect combination of value and performance and is the ideal choice of lock for typical commercial applications. Our 3200 Series is an economical alternative to Grade 1 when Grade 1 is not required. It is a perfect complement to our 3500 Series for extra protection against break-in and is backed by a lifetime warranty.

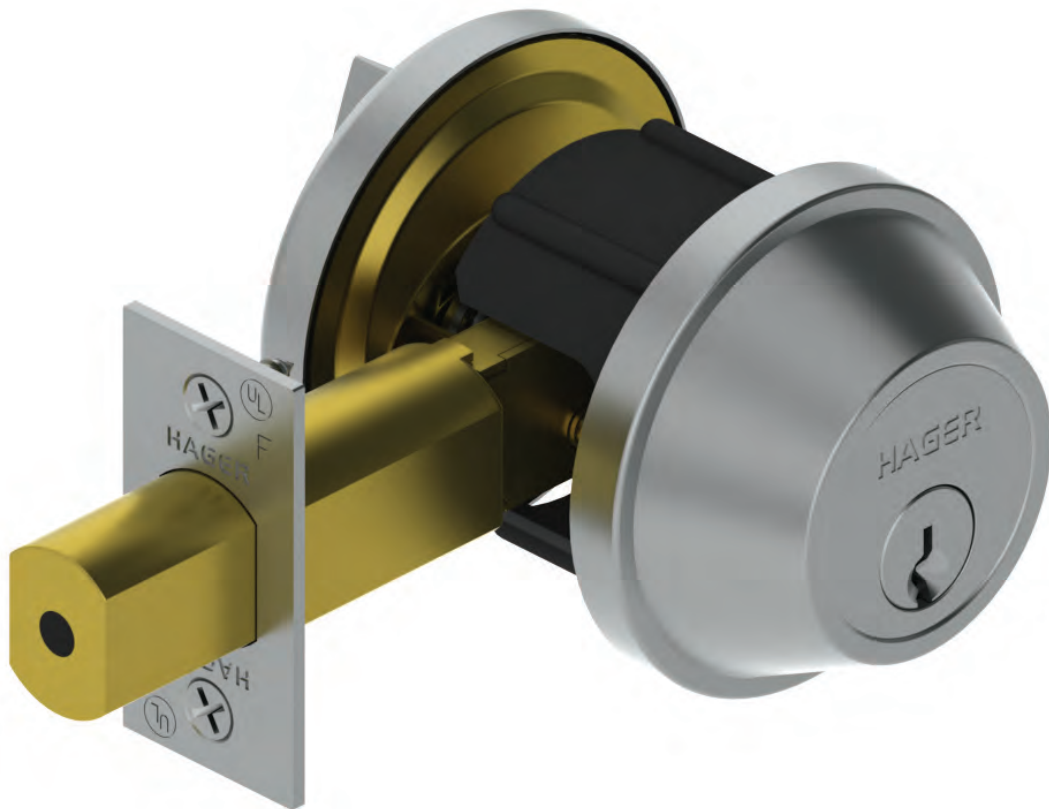



**3200 SERIES - HOW TO ORDER**

**3214 2-3/4" US26D US26 SCC**

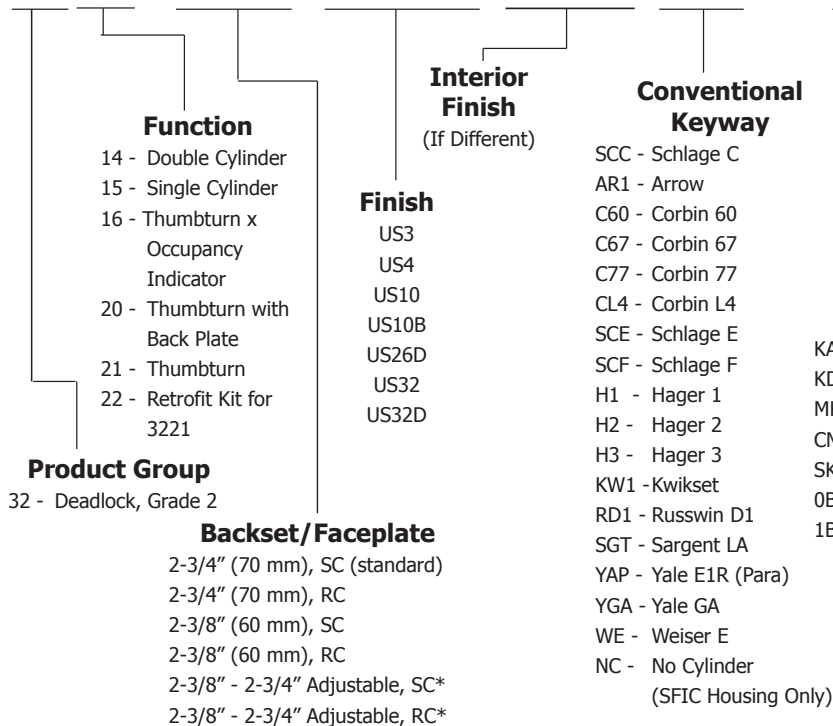

**KD ASA 6PKEY**

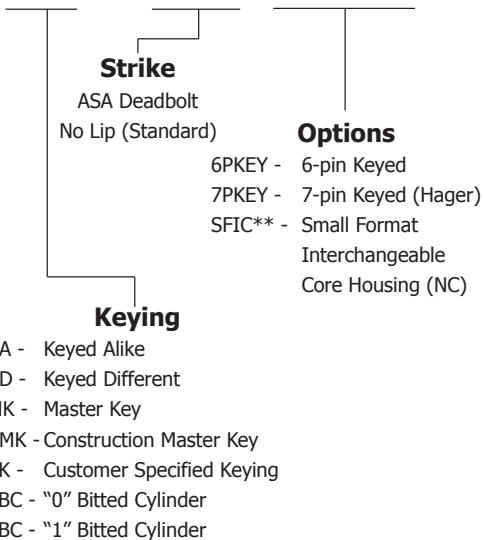





Notes:  
 1. If masterkeyed, include completed master key form sheet with order (available on page 88 or www.hagerco.com).  
 2. For additional keying information, please refer to cylinder, core, and keying section of catalog (page 73).

\* Adjustable backset deadbolts supplied with 3220 and 3221.  
 \*\* Small format interchangeable core sold separately. Available in Best Keyways (A Standard), or Hager Keyways (optional).

Ordering example: **3214 2-3/4" US26D NC SFIC**

**3200 SERIES FUNCTION CHART**

Function	Function No.	Function Description	ANSI No.
 Double Cylinder	14	Deadbolt thrown or retracted by key from either side. Bolt automatically deadlocks when fully thrown.	E2142
 Cylinder x Thumbturn	15	Deadbolt thrown or retracted by key from outside or by inside thumbturn. Bolt automatically deadlocks when fully thrown.	E2152
 Thumbturn x Occupancy Indicator	16	Deadbolt operated by thumbturn inside, emergency override key outside. Outside indicator displays "In Use" when deadbolt is thrown and "Vacant" when deadbolt is retracted.	_____
 Thumbturn w/ Blank Plate (no cylinder)	20	Deadbolt thrown or retracted by thumbturn only. Outside blank plate. Bolt automatically deadlocks when fully thrown.	E21112
 Thumbturn Only (no cylinder)	21	Deadbolt thrown or retracted by thumbturn only. No outside trim. Bolt automatically deadlocks when fully thrown.	E2192

Note: 3222 available for retrofit applications, converting a 3221 into a 3220.



## 3200 SERIES - GRADE 2 DEADLOCK - AUXILIARY

**WARRANTY** | Lifetime warranty

**FEATURES**

- Non-handed
- Conventional cylinder or Small Format Interchangeable Core option available

Certifications:

- BHMA Certified ANSI A156.5 Grade 2
- ANSI A250.13 Severe Windstorm Resistant Component
- UL/cUL Listed for all functions up to 3 hours for "A" label single doors
- UL10C Positive Pressure Rated
- UL10B Neutral Pressure Rated
- ADA - Thumbturn

Options:

- Split finish
- Additional deadbolts and strikes available

**SPECIFICATIONS**

Standard Door Prep:

- Cylinder hole: 2-1/8" (54 mm) diameter (bore)
- Latch hole: 1" (25 mm) diameter (cross bore)

Exposed Trim:

Wrought brass, bronze or stainless steel

Mechanism:

Steel, zinc dichromate plating

Keys:

Two operating keys supplied per lock

Cylinders/Cores:

- Brass - Keyed Different - Schlage C Keyway standard
- Cylinder drilled 6-pin, Keyed 5-pin - Standard
- Other keying options, including keyed 6-pin, available from the factory (see Cylinder, Core and Keying section)
- Small Format Interchangeable Core option available
- SFIC uncombined or combined, brass 6- or 7-pin cores sold separately

Door Thickness:

- 1-3/4" (45 mm) only - 3214 SFIC and 3216
- 1-3/8" - 1-3/4" (35 mm - 45 mm) - Standard
- 2" - 2-1/4" (51 mm - 57 mm) available for conventional cylinder only - Must specify

Backset:

- 2-3/4" (70 mm) - Standard
- 2-3/8" (60 mm) - Optional
- 2-3/8" - 2-3/4" adjustable backset supplied with 3220 and 3221 (not available on 3214 or 3215)

Latchbolt:

- 1" (25 mm) Throw - Brass with concealed hardened steel roller to prevent sawing or cutting
- 1-1/8" x 2-1/4" (29 mm x 57 mm) square corner faceplate

Strikes:

- 3930 Square Corner, 1-1/8" x 2-3/4" (29 mm x 70 mm) with dustbox - Standard
- 3929 ASA Deadbolt Strike - Optional

Functions:

14 Double Cylinder, 15 Cylinder x Thumbturn, 16 Thumbturn x Occupancy Indicator, 20 Thumbturn w/ Blank Plate, 21 Thumbturn Only

Notes:

3222 retrofit kit available for use with 21 function

**FINISHES**

US3, US4, US10, US10B, US26D, US32, US32D

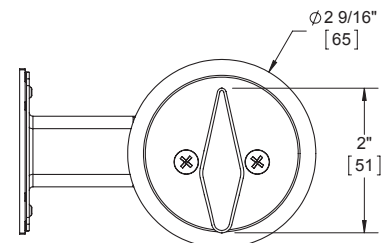
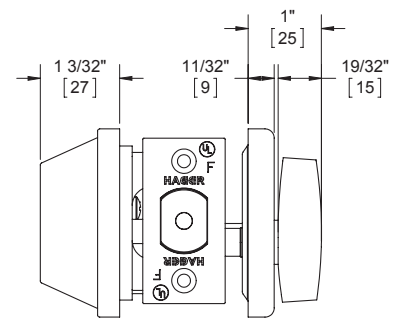



## 3200 SERIES LATCHBOLTS

## 3200 SERIES STRIKES



**3940**  
**2-3/4" (70 mm) Backset Latchbolt - Standard**

- Square and round corner available
- 1-1/8" x 2-1/4" (29 mm x 57 mm) faceplate
- Round corner not available in US32/32D

**3941**  
**2-3/8" (60 mm) Backset Latchbolt - Optional**

- Square and round corner available
- 1" x 2-1/4" (25 mm x 57 mm) faceplate
- Round corner not available in US32/32D



**3942**  
**2-3/8" (60 mm) - 2-3/4" (70 mm) Adjustable Backset Latchbolt - Standard for 3220 and 3221**

- Square and round corner available
- 1-1/8" x 2-1/4" (29 mm x 57 mm) faceplate - Standard
- 1" x 2-1/4" (25 mm x 57 mm) faceplate - Optional
- Round corner not available in US32/32D



**3929**  
**ASA Deadbolt Strike - Optional**  
1-1/4" x 4-7/8" (32 mm x 124 mm)



**3930**  
**Strike Plate - Standard**  
• 1-1/8" x 2-3/4" (29 mm x 70 mm)  
• Dust box included



# 3400 Series



Hager 3400 Series Grade 1 lock is designed and engineered to withstand the most abusive environments. We've categorized it 'extra heavy duty' and you can rest assured that it has been tested against heavy use, impact, strength, resistance, and abuse. We're so confident in our 3400 Series lock, it's backed by a lifetime warranty. The exceptional quality of our 3400 Series lock has made it incredibly successful in application after application across the country and around the globe.

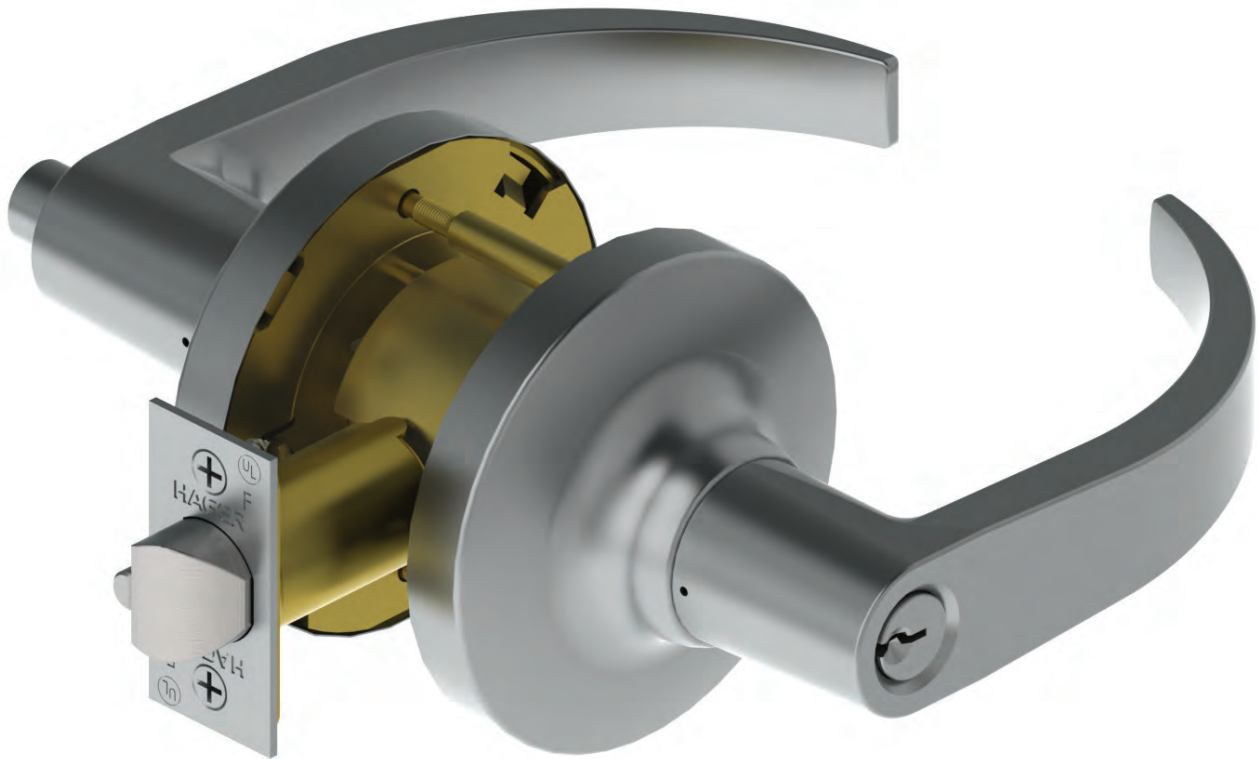



**3400 SERIES - HOW TO ORDER**

3453	2- <sup>3</sup> / <sub>4</sub> "	US26D	US26	WTN	SCC	KD	ASA	TW	
<b>Function</b> 10 - Passage 17 - Single Dummy 40 - Privacy 50 - Entry/Office 53 - Entry 70 - Classroom 73 - Corridor 80 - Storeroom 95 - Intruder Classroom		<b>Interior Finish</b> (If Different)		<b>Conventional Keyway</b> SCC - Schlage C AR1 - Arrow C60 - Corbin 60 C67 - Corbin 67 C77 - Corbin 77 CL4 - Corbin L4 SCE - Schlage E SCF - Schlage F H1 - Hager 1 H2 - Hager 2 H3 - Hager 3 KW1 - Kwikset RD1 - Russwin D1 SGT - Sargent LA YAP - Yale E1R (Para) YGA - Yale GA WE - Weiser E NC - No Cylinder (SFIC and LFIC Only)		<b>Strike</b> ASA (Standard) Full RC Full TEE		<b>Options</b> TW - Tactile Warning LL - Leadlined EL24 - Fail Safe 24 Volt EL12 - Fail Safe 12 Volt EU24 - Fail Secure 24 Volt EU12 - Fail Secure 12 Volt RX - Request to Exit ELRX24 - Fail Safe 24 Volt with Request to Exit ELRX12 - Fail Safe 12 Volt with Request to Exit EURX24 - Fail Secure 24 Volt with Request to Exit EURX12 - Fail Secure 12 Volt with Request to Exit 6PKEY - 6-pin Keyed 7PKEY - 7-pin Keyed (Hager Only) SFIC* - Small Format Interchangeable Core Prep LFIC** - Large Format Interchangeable Core Prep (Leverset Only) ANTI - Antimicrobial Coating (26D only)	
<b>Backset/Faceplate</b> 2-3/4" (70 mm), SC (Standard) 2-3/4" (70 mm), RC 2-3/8" (60 mm), SC 2-3/8" (60 mm), RC		<b>Finish</b> US3 - Knob/Lever US4 US10 US10B US26 US26D US32D - Knob Only		<b>Lever Style</b> APL - Apollo Knob ARC - Archer Lever AUG - August Lever WTN - Withnell Lever		<b>Keying</b> KA - Keyed Alike KD - Keyed Different MK - Master Key CMK - Construction Master Key SK - Customer Specified Keying OBC - "0" Bitted Cylinder 1BC - "1" Bitted Cylinder			
<b>Product Group</b> 34 - Cylindrical, Grade 1									

**Notes:**

1. If masterkeyed, include completed master key form with order (available on page 88 or www.hagerco.com).
2. For additional keying information, please refer to cylinder, core, and keying section of catalog (page 73).

\* Small format interchangeable core sold separately. Available in Best Keyways (A Standard) or Hager Keyways (optional).









\*\* Large format interchangeable core sold separately. Available in Schlage C Keyway only.

**Ordering example: 3453 2-3/4" US26D WTN NC ASA SFIC : 3453 2-3/4" US26D WTN NC ASA LFIC**





## 3400 SERIES - FUNCTION CHART

Function	Function No.	Function Description	ANSI No.	
<b>Non-Keyed</b>				
	Passage	10	Latchbolt operated by lever from either side at all times.	F75
	Dummy - Single	17	Pull one side, no mechanical operation.	-
	Privacy	40	Latchbolt operated by lever from either side. Outside lever is locked by push button inside and unlocked by emergency release outside, operating inside lever or closing door.	F76A
<b>Keyed</b>				
	Entry/Office	50	Deadlocking latchbolt operated by lever from either side except when outside lever is locked by push button on inside lever. When outside lever is locked, operating key in outside lever or operating inside lever unlocks push button. Closing door does not release push button.	F82A
	Entry	53	Deadlocking latchbolt by lever either side, except when turn button inside locks outside lever. Pushing turn button in locks outside lever, requiring use of key outside to unlock. (Lever handle is freewheeling in locked position.) Turning inside lever unlocks outside lever. Pushing in and turning button locks outside lever, requiring key at all times. Turning inside lever does not unlock outside lever until button is manually turned to unlocked position. Inside lever always operates latchbolt.	F109
	Classroom	70	Deadlocking latchbolt operated by lever from either side except when outside lever is locked from outside by key. When outside lever is locked, latchbolt is operated by inside lever.	F84
	Corridor	73	Deadlocking latchbolt operated by lever from either side except when outside lever is locked by key in outside lever or by push button on inside. Key in outside lever locks or unlocks outside lever. Operating inside lever releases push button. Closing door releases push button. Inside lever always operates latchbolt.	F90
	Storeroom	80	Deadlocking latchbolt operated by key in outside lever, or by operating inside lever. Outside lever is always locked. Inside lever is always unlocked.	F86
	Intruder Classroom*	95	Deadlocking latchbolt operated by lever from either side. Key either inside or outside locks or unlocks outside lever. Inside lever always operates latchbolt.	F110

Notes: \*Intruder Classroom includes locking direction indicator stamped on the inside rose standard.







**3400 SERIES - LEVER OPTIONS**

**APOLLO KNOB**

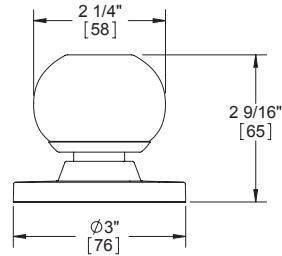

**ARCHER LEVER**

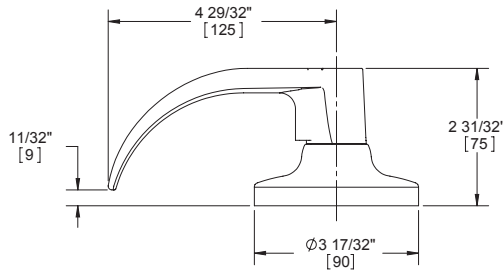

**AUGUST LEVER**

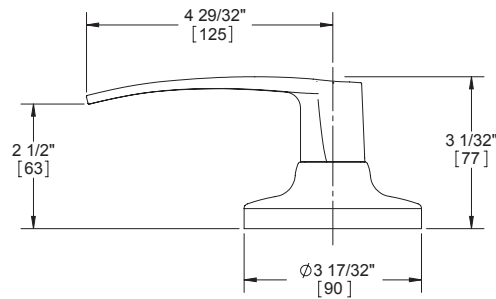

**WITHNELL LEVER**

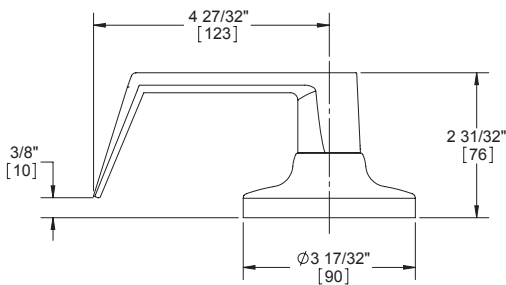

Optional tactile warning available on all lever styles (only outside lever will include raised surfaces unless otherwise specified).





## 3400 SERIES - GRADE 1 CYLINDRICAL - HEAVY DUTY

<b>WARRANTY</b>	Lifetime warranty
<b>FEATURES</b>	<ul style="list-style-type: none"> <li>• Heavy duty commercial, industrial, institutional</li> <li>• No exposed mounting screws</li> <li>• Non-handed</li> <li>• Conventional cylinder, Small Format Interchangeable Core, and Large Format Interchangeable Core option available</li> </ul>
Certifications:	<ul style="list-style-type: none"> <li>• BHMA Certified ANSI A156.2 Series 4000 Grade 1</li> <li>• ADA Compliant ANSI A117.1 Accessibility Code (levers only)</li> <li>• ANSI A250.13 Severe Windstorm Resistant Component</li> <li>• UL/cUL Listed for all functions up to 3 hours for "A" label doors</li> <li>• UL10C Positive Pressure Rated</li> <li>• UL10B Neutral Pressure Rated</li> </ul>
Lever Options:	Apollo knob; Archer, August, Withnell levers
Options:	<ul style="list-style-type: none"> <li>• Lead lined (leversets only)</li> <li>• Tactile warning (levers only)</li> <li>• Antimicrobial coating (26D finish only)</li> <li>• Split finish</li> <li>• Additional latchbolts and strikes available</li> </ul>
<b>SPECIFICATIONS</b>	
Standard Door Prep:	<ul style="list-style-type: none"> <li>• 2-1/8" (54 mm) diameter (bore)</li> <li>• Latch hole: 1" (25 mm) diameter (cross bore)</li> </ul>
Exposed Trim:	<ul style="list-style-type: none"> <li>• Knobs: Wrought brass or stainless steel</li> <li>• Levers: Cast zinc</li> <li>• Rose: Wrought brass or stainless steel</li> </ul>
Rose Diameter:	3-17/32" (90 mm) levers; 3" (76 mm) knobs
Lock Chassis:	<ul style="list-style-type: none"> <li>• Heavy gauge steel, zinc dichromated for corrosion resistance</li> <li>• Free wheeling (levers only)</li> <li>• Thru-bolt mounting (levers only)</li> </ul>
Keys:	Two operating keys supplied per lock
Cylinders/Cores:	<ul style="list-style-type: none"> <li>• Brass 6-pin, keyed different - Schlage C Keyway - Standard</li> <li>• Cylinder drilled 6-pin, Keyed 5-pin - Standard</li> <li>• Other keying options, including keyed 6-pin, available from factory (see cylinder, core and keying section)</li> <li>• Small Format Interchangeable Core option available</li> <li>• SFIC uncombined or combined, brass 6- or 7-pin cores sold separately</li> <li>• Large Format Interchangeable Core option available - leversets only</li> <li>• LFIC zero bitted or combined, brass 6-pin cores sold separately - Schlage C only</li> </ul>
Door Thickness:	<ul style="list-style-type: none"> <li>• Knobs: 1-3/8" - 1-3/4" (35 mm - 45 mm)</li> <li>• Levers: 1-3/8" - 2" (35 mm - 51 mm)</li> </ul>
Backset:	<ul style="list-style-type: none"> <li>• 2-3/4" (70 mm) - Standard</li> <li>• 2-3/8" (60 mm) - Optional</li> <li>• 3-3/4" (94 mm) - Optional</li> <li>• 5" (128 mm) - Optional</li> </ul>
Latchbolt:	<ul style="list-style-type: none"> <li>• 1/2" (13 mm) throw, stainless steel</li> <li>• 1-1/8" x 2-1/4" (29 mm x 57 mm) faceplate</li> <li>• Square corner faceplates standard, round corner available</li> <li>• Deadlocking latchbolt prevents manipulation when door is closed; keyed functions only</li> <li>• 3/4" (18 mm) latch available</li> </ul>
Strike:	3935 ASA 1-1/4" x 4-7/8" (32 mm x 124 mm) strike - Standard
Functions:	10 Passage, 17 Dummy, 40 Privacy, 50 Entry/Office, 53 Entry, 70 Classroom, 73 Corridor (levers only), 80 Storeroom, 95 Intruder Classroom (levers only)
<b>FINISHES</b>	<ul style="list-style-type: none"> <li>• US3, US4, US10, US10B, US26, US26D (levers only)</li> <li>• US3, US32D (knobs only)</li> </ul>





## 3400 SERIES - ELECTRIFIED - GRADE 1 CYLINDRICAL HEAVY DUTY

### WARRANTY

- Lifetime warranty on mechanical locking components
- One-year warranty on electric components

### FEATURES

- Deadlocking latchbolt
- Key override allows latchbolt to be momentarily retracted with the key even though electrically locked. Note that locks that are electrically unlocked may not be locked via the key cylinder.
- Inside lever always allows egress
- Interface with life-safety systems
- Continuous-duty solenoids



Function:

80 - Storeroom

Applications:

- Provides remote locking and unlocking ideal for access control where added security is necessary
- Stairtower doors
- Office doors
- Classrooms
- Elevator lobby doors
- Computer rooms
- Hospital equipment rooms
- Pharmaceutical storage rooms

Voltage:

- 12V AC/DC; current - .250AMP
- 24V AC/DC; current - .150AMP
- Specify 12V or 24V when ordering

### FINISHES

US3, US4, US10, US10B, US26, US26D

Function	Function No.	Function Description
Storeroom - Fail Safe	3480EL	Outside lever continuously locked electrically. Latchbolt operable from the outside by key, by breaking electric current, or by power failure. Auxiliary latch deadlocks latchbolt when door is closed. Inside always free for immediate egress.
Storeroom - Fail Secure	3480EU	Outside lever continuously locked. Latchbolt operable from the outside by key or by applying electrical current. Auxiliary latch deadlocks latchbolt when door is closed. Inside always free for immediate egress.
Storeroom - Request to Exit	3480RX	Monitors inside lever rotation. Incorporates into fire alarm system or in conjunction with an electromagnet.
Storeroom - Fail Safe w/ Request to Exit	3480ELRX	Outside lever continuously locked electrically. Latchbolt operable from the outside by key, by breaking electric current, or by power failure. Auxiliary latch deadlocks latchbolt when door is closed. Inside always free for immediate egress. Inside lever rotation is monitored. Incorporates into fire alarm system.
Storeroom - Fail Secure w/ Request to Exit	3480EURX	Outside lever continuously locked. Latchbolt operable from the outside by key or by applying electrical current. Auxiliary latch deadlocks latchbolt when door is closed. Inside always free for immediate egress. Inside lever rotation is monitored. Incorporates into fire alarm system.





## 3400 SERIES - POWER SUPPLIES

See power supply area within the Electrified Products section for more details on our full selection of power supplies. Hager 2903, 2908 and 2909 power supplies are designed to power locking devices. Their features include:

- UL Listed
- Filtered/regulated 24VDC
- Overload protection
- Over voltage protection
- Short circuit protection
- Surge suppression on Fail Safe and Fail Secure outputs
- Fire alarm input standard

### 2903 Power Supply Includes:

- 24VDC, 2Amp
- Automatically accepts 120 or 240VAC input
- Auxiliary 24VDC output for stand alone devices
- Switch 24VDC outputs for fail safe or fail secure locking hardware
- Surge suppression on Fail Safe and Fail Secure outputs

### 2908 Power Supply Includes:

- Field selectable 12VDC or 24VDC, 1Amp
- 115VAC standard (230VAC optional)
- Separate PTC protected charging for battery backup
- LED status indicator
- Modular design allows optional components to fit any application (see Electrified Catalog for a full list of components)

### 2909 Power Supply Includes:

- Field selectable 12VDC or 24VDC, 2Amp
- 115VAC standard (230VAC optional)
- Separate PTC protected charging for battery backup
- LED status indicator
- Modular design allows optional components to fit any application (see Electrified Catalog for a full list of components)

## Hager Locking System

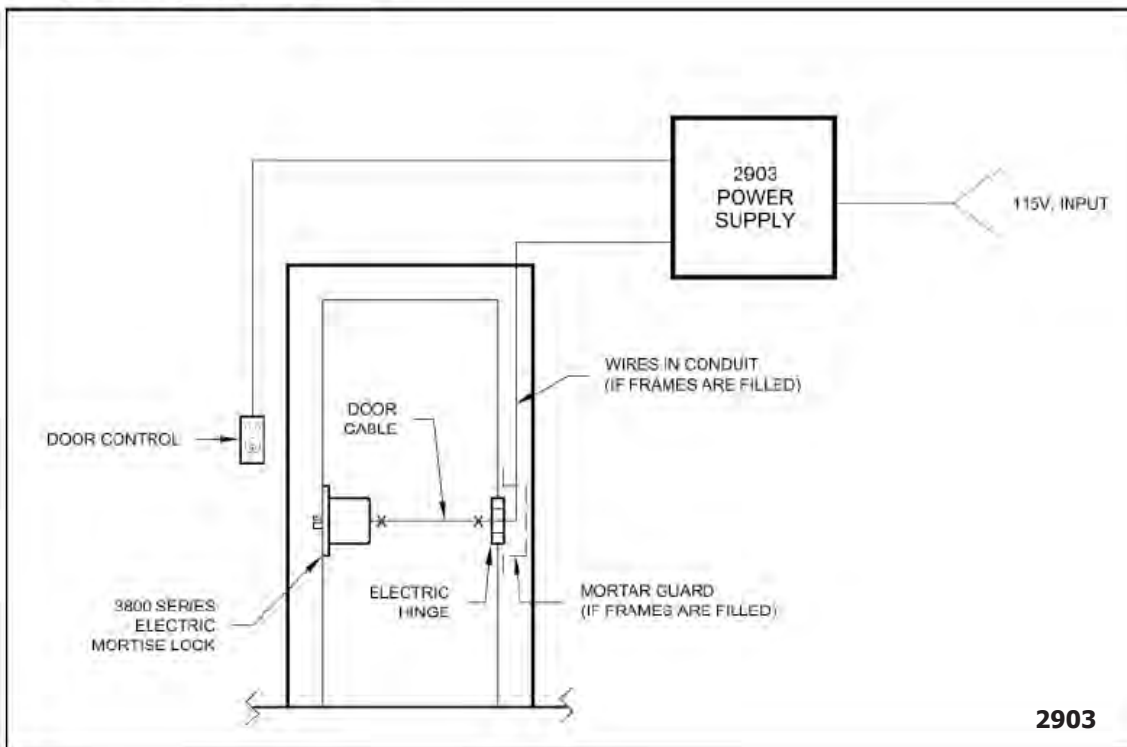



## 3400 SERIES - LATCHBOLTS

### Spring Latches



**3943**  
**2-3/4" (70 mm) Backset**  
**Passage Spring Latch - Standard**  
 • Square and round corner available  
 • 1-1/8" x 2-1/4" (29 mm x 57 mm) faceplate

**3945**  
**2-3/8" (60 mm) Backset**  
**Passage Spring Latch**  
 • Square and round corner available  
 • 1-1/8" x 2-1/4" (29 mm x 57 mm) faceplate



**3964**  
**2-3/4" (70 mm) Backset**  
**Privacy Spring Latch - Standard**  
 • Square and round corner available  
 • 1-1/8" x 2-1/4" (29 mm x 57 mm) faceplate

**3966**  
**2-3/8" (60 mm) Backset**  
**Privacy Spring Latch**  
 • Square and round corner available  
 • 1-1/8" x 2-1/4" (29 mm x 57 mm) faceplate

### Backset Extension Links

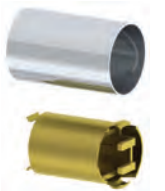

**3916**  
**3-3/4" (95 mm) Backset**  
**Extension Link**  
 Must use with 2-3/8" (60 mm) backset latch to achieve 3-3/4" total backset

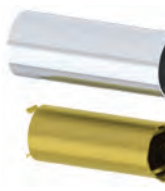

**3936**  
**5" (127 mm) Backset**  
**Extension Link**  
 Must use with 2-3/4" (70 mm) backset latch to achieve 5" total backset

### Dead Latches



**3932**  
**2-3/4" (70 mm) Backset**  
**Dead Latch**  
 • 3/4" (18 mm) throw  
 • Square corner only  
 • For use on fire rated pairs of doors  
 • 1-1/8" x 2-1/4" (29 mm x 57 mm) faceplate



**3944**  
**2-3/4" (70 mm) Backset**  
**Dead Latch - Standard**  
 • Square and round corner available  
 • For use with all keyed functions other than corridor  
 • 1-1/8" x 2-1/4" (29 mm x 57 mm) faceplate

**3946**  
**2-3/8" (60 mm) Backset**  
**Dead Latch**  
 • Square and round corner available  
 • For use with all keyed functions other than corridor  
 • 1-1/8" x 2-1/4" (29 mm x 57 mm) faceplate



**3992**  
**2-3/8" (60 mm) Backset**  
**Dead Latch - Corridor Function Only**  
 • Square and round corner available  
 • 1-1/8" x 2-1/4" (29 mm x 57 mm) faceplate

**3993**  
**2-3/4" (70 mm) Backset**  
**Dead Latch - Corridor Function Only**  
 • Square and round corner available  
 • 1-1/8" x 2-1/4" (29 mm x 57 mm) faceplate





## 3400 SERIES - STRIKES

## 3400 SERIES ACCESSORIES



### 3933

#### T-Strike with Plastic Dust Box

- 1-1/8" x 2-3/4" (29 mm x 70 mm)
- Dust box included



### 3911

#### Thru-Bolt Jig

For lever set only



### 3934

#### Full Lip Strike

1-5/8" x 2-1/4" (41 mm x 57 mm)



### 3935

#### Standard ASA Strike Plate

- 1-1/4" x 4-7/8" (32 mm x 124 mm)
- 1-5/16" lip
- Other lengths available upon request



### 3958

#### Full Lip Strike with Round Corner

- 1-5/8" x 2-1/4" (41 mm x 57 mm)
- 1/4" (6 mm) radius



# 3500 Series



Hager 3500 Series Grade 2 lock provides a perfect combination of value and performance and is the ideal choice of lock for typical commercial applications. It is an economical alternative to Grade 1 when Grade 1 is not required. Our 3500 Series lock offers superior dependability and is backed by a lifetime warranty.

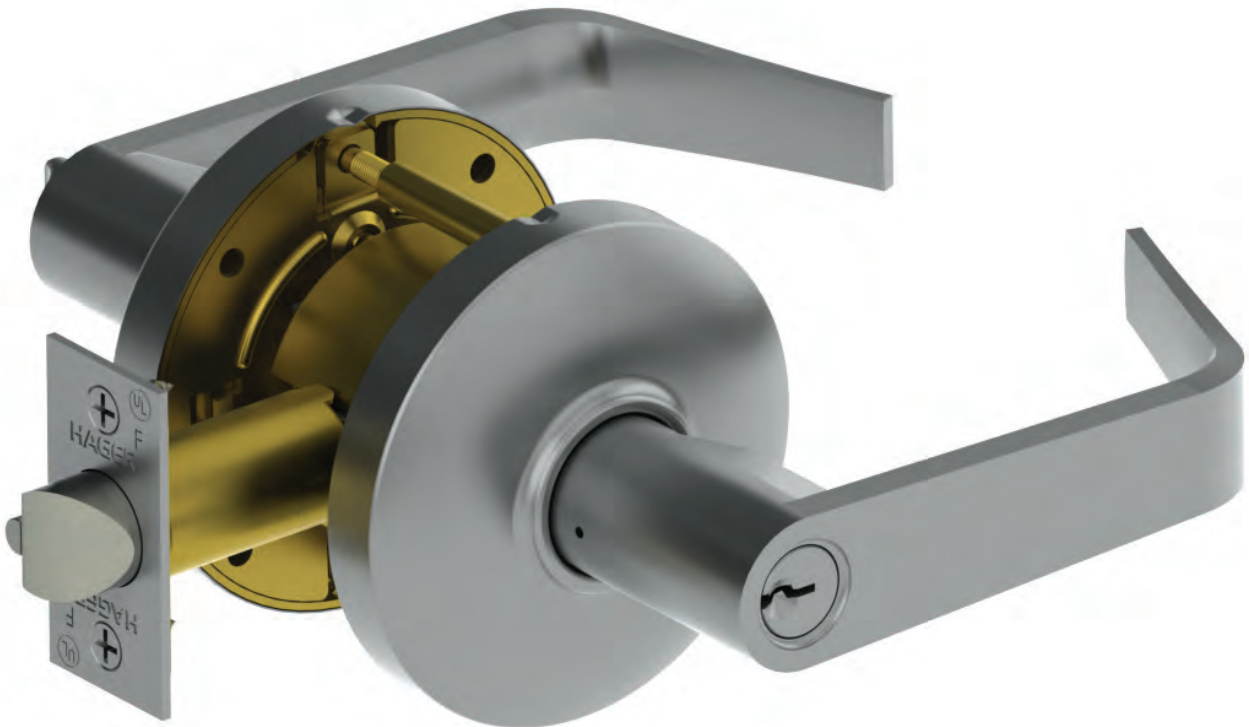





## 3500 SERIES - HOW TO ORDER

3553	2- <sup>3</sup> / <sub>4</sub> "	US26D	US26	WTN	SCC	KD	ASA	TW	
<b>Function</b> 10 - Passage 17 - Single Dummy 25 - Exit 27 - Double Dummy 40 - Privacy 50 - Entry/Office 53 - Entry 70 - Classroom 73 - Corridor 79 - Keyed Communicating 80 - Storeroom		<b>Interior Finish</b> (If Different)		<b>Conventional Keyway</b> SCC - Schlage C AR1 - Arrow C60 - Corbin 60 C67 - Corbin 67 C77 - Corbin 77 CL4 - Corbin L4 SCE - Schlage E SCF - Schlage F H1 - Hager 1 H2 - Hager 2 H3 - Hager 3 KW1 - Kwikset RD1 - Russwin D1 SGT - Sargent LA YAP - Yale E1R (Para) YGA - Yale GA WE - Weiser E NC - No Cylinder (SFIC Housing Only)		<b>Strike</b> ASA (standard) Full Lip RC Full Lip TEE		<b>Options</b> TW - Tactile Warning LL - Leadlined 6PKEY - 6-pin Keyed 7PKEY - 7-pin Keyed (Hager) SFIC* - Small Format Interchangeable Core Prep ANTI - Antimicrobial Coating (26D Only)	
<b>Backset/Faceplate</b> 2-3/4" (70 mm), SC (standard) 2-3/4" (70 mm), RC 2-3/4" (70 mm) Drive-In 2-3/8" (60 mm), SC 2-3/8" (60 mm), RC 2-3/8" (60 mm) Drive-In		<b>Finish</b> US3 - Knob/Lever US4 US10 US10B US26 US26D US32D - Knob Only		<b>Lever Style</b> APL - Apollo Knob ARC - Archer Lever AUG - August Lever WTN - Withnell Lever		<b>Keying</b> KA - Keyed Alike KD - Keyed Different MK - Master Key CMK - Construction Master Key SK - Customer Specified Keying 0BC - "0" Bitted Cylinder (Conventional Only) 1BC - "1" Bitted Cylinder (Conventional Only)			
<b>Product Group</b> 35 - Cylindrical, Grade 2									

**Notes:**

1. If masterkeyed, include completed master key form with order (available on page 88 or www.hagerco.com).
2. For additional keying information, please refer to cylinder, core, and keying section of catalog (page 73).









\* Small format interchangeable core sold separately. Available in Best Keyways (A Standard) or Hager Keyways (optional).

**Ordering example: 3553 2-3/4" US26D WTN NC ASA SFIC**







## 3500 SERIES - FUNCTION CHART

Function	Function No.	Function Description	ANSI No.	
<b>Non-Keyed</b>				
	Passage	10	Latchbolt operated by lever from either side at all times.	F75
	Dummy - Single	17	Pull one side, no mechanical operation (back to back).	-
	Exit	25	Blank plate outside (13/16" [31 mm] projection). Inside lever always unlocked.	F111
	Dummy - Double	27	Pull both sides. No mechanical operation (back to back).	-
	Privacy	40	Latchbolt operated by lever from either side. Outside lever is locked by push button inside and unlocked by emergency release outside, operating inside lever or closing door.	F76A
<b>Keyed</b>				
	Entry/Office	50	Deadlocking latchbolt operated by lever from either side except when outside lever is locked by push button on inside lever. When outside lever is locked, operating key in outside lever or operating inside lever unlocks push button and retracts latchbolt. Closing door does not release push button.	F82A
	Entry	53	Deadlocking latchbolt by lever either side, except when turn button inside locks outside lever. Pushing turn button in locks outside lever, requiring use of key outside to unlock (lever handle is freewheeling in locked position). Turning inside lever unlocks outside lever. Pushing in and turning button locks outside lever, requiring key at all times. Turning inside lever does not unlock outside lever until button is manually turned to unlocked position. Inside lever always operates latchbolt.	F109
	Classroom	70	Deadlocking latchbolt operated by lever from either side except when outside lever is locked from outside by key. When outside lever is locked, latchbolt is operated by inside lever.	F84



## 3500 SERIES - FUNCTION CHART

Function	Function No.	Function Description	ANSI No.
Keyed (continued)			
 Corridor	73	Deadlocking latchbolt operated by lever from either side except when outside lever is locked by key in outside lever or by push button. Key in outside lever locks or unlocks outside lever. Operating inside lever releases push button. Closing door releases push button. Inside lever always operates latchbolt.	F90
 Keyed Communicating	79	Deadlocking latchbolt by inside lever except when locked by key. Non-removable blank plate outside (13/16" [31 mm] projection).	F113
 Storeroom	80	Deadlocking latchbolt operated by key in outside lever, or by operating inside lever. Outside lever is always locked. Inside lever is always unlocked.	F86





**3500 SERIES - LEVER OPTIONS**

**APOLLO KNOB**

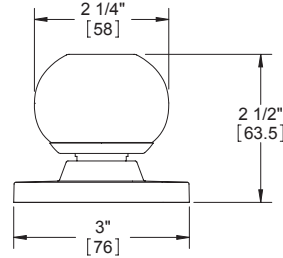

**ARCHER LEVER**

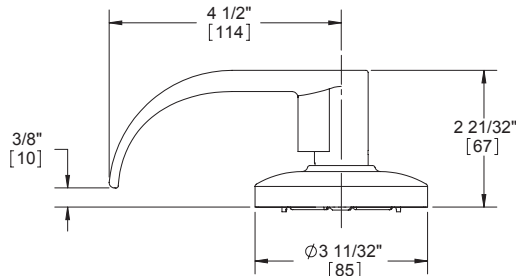

**AUGUST LEVER**

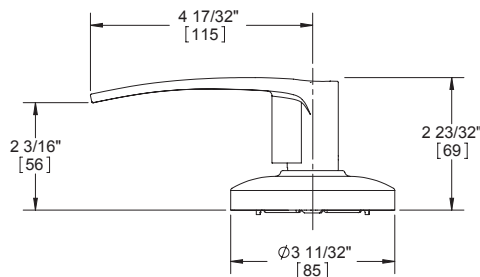

**WITHNELL LEVER**

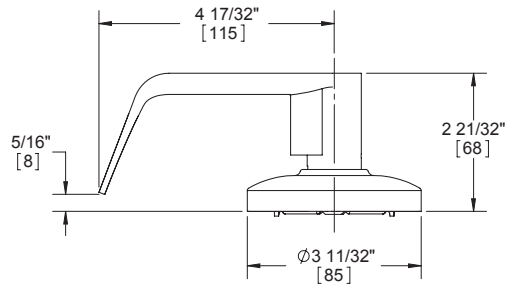

Notes: Optional tactile warning available on all lever styles (only outside lever will include raised surfaces unless otherwise specified).



## 3500 SERIES - GRADE 2 CYLINDRICAL - STANDARD DUTY COMMERCIAL

### WARRANTY

Lifetime warranty

### FEATURES

- No exposed mounting screws
- Non-handed
- Conventional cylinder or Small Format Interchangeable Core option available

### Certifications:

- BHMA Certified ANSI A156.2 Series 4000 Grade 2
- ADA Compliant ANSI A117.1 Accessibility Code (levers only)
- ANSI A250.13 Severe Windstorm Resistant Component
- UL/cUL Listed for all functions up to 3 hours for "A" label single doors
- UL10C Positive Pressure Rated
- UL10B Neutral Pressure Rated

### Lever Options:

Apollo knob; Archer, August, Withnell levers

### Options:

- Lead lined (leversets only)
- Tactile warning (levers only)
- Antimicrobial coating (26D finish only)
- Split finish
- Additional latchbolts and strikes available



### SPECIFICATIONS

#### Standard Door Prep:

- 2-1/8" (54 mm) diameter (bore)
- Latch hole: 1" (25 mm) diameter (cross bore)

#### Exposed Trim:

- Knobs: Wrought brass or stainless steel
- Levers: Cast zinc
- Rose: Wrought brass or stainless steel

#### Rose Diameter:

3-11/32" (85 mm) levers; 3" (76 mm) knobs

#### Lock Chassis:

- Heavy gauge steel, zinc dichromated for corrosion resistance
- Free wheeling (levers only)
- Removable thru-bolts (Note: Failure to install thru-bolts and removable screw posts voids BHMA certification, UL rating and warranty)

#### Keys:

Two operating keys supplied per lock

#### Cylinders/Cores:

- Brass - keyed different - Schlage C Keyway - Standard
- Cylinder drilled 6-pin, keyed 5-pin - Standard
- Other keying options, including keyed 6-pin, available from factory (see cylinder, core and keying section)
- Small Format Interchangeable Core option available
- SFIC uncombined or combined, brass 6- or 7-pin cores sold separately

#### Door Thickness:

- Knobs: 1-3/8" - 1-3/4" (35 mm - 45 mm)
- Levers: 1-3/8" - 2" (35 mm - 51 mm)

#### Backset:

- 2-3/4" (70 mm) - Standard
- 2-3/8" (60 mm) - Optional
- 3-3/4" (94 mm) - Optional
- 5" (128 mm) - Optional

#### Latchbolt:

- 1/2" (13 mm) throw, stainless steel
- 1-1/8" x 2-1/4" (29 mm x 57 mm) faceplate for 2-3/4" (70 mm) backset
- 1" x 2-1/4" (29 mm x 57 mm) faceplate for 2-3/8" (60 mm) backset
- Deadlocking latchbolt prevents manipulation when door is closed; keyed functions and 25 function only
- Square corner faceplate standard, round corner available

#### Strike:

3935 ASA 1-1/4" x 4-7/8" (32 mm x 124 mm) strike - Standard

#### Functions:

10 Passage, 17 Dummy, 25 Exit (only), 27 Back to Back Dummy (levers only), 40 Privacy, 50 Entry/Office, 53 Entry, 70 Classroom, 73 Corridor (levers only), 79 Keyed Communicating, 80 Storeroom  
(Notes: Blank plate projection is 13/16" for functions 25 and 79)

### FINISHES

- US3, US4, US10, US10B, US26, US26D (levers only)
- US3, US32D (knobs only)





## 3500 SERIES - LATCHBOLTS

### Spring Latches



- 3947**  
**2-3/4" (70 mm) Backset**  
**Passage Spring Latch**
- Square and round corner available
  - 1-1/8" x 2-1/4" (29 mm x 57 mm) faceplate

- 3949**  
**2-3/8" (60 mm) Backset**  
**Passage Spring Latch**
- Square and round corner available
  - 1" x 2-1/4" (25 mm x 57 mm) faceplate



- 3965**  
**2-3/4" (70 mm) Backset**  
**Privacy Spring Latch**
- Square and round corner available
  - 1-1/8" x 2-1/4" (29 mm x 57 mm) faceplate

- 3967**  
**2-3/8" (60 mm) Backset**  
**Privacy Spring Latch**
- Square and round corner available
  - 1" x 2-1/4" (25 mm x 57 mm) faceplate

### Dead Latches



- 3948**  
**2-3/4" (70 mm) Backset**  
**Dead Latch**
- Square and round corner available
  - 1-1/8" x 2-1/4" (29 mm x 57 mm) faceplate
  - For use with all keyed functions other than corridor

- 3950**  
**2-3/8" (60 mm) Backset**  
**Dead Latch**
- Square and round corner available
  - 1" x 2-1/4" (25 mm x 57 mm) faceplate
  - For use with all keyed functions other than corridor



- 3995**  
**2-3/4" (70 mm) Backset**  
**Dead Latch - Corridor Function Only**
- Square and round corner available
  - 1-1/8" x 2-1/4" (29 mm x 57 mm) faceplate

- 3994**  
**2-3/8" (60 mm) Backset**  
**Dead Latch - Corridor Function Only**
- Square and round corner available
  - 1" x 2-1/4" (25 mm x 57 mm) faceplate

### Optional Drive-In Spring Latches



- 3922**  
**2-3/4" (70 mm) Backset**  
**Passage Spring Latch**

- 3925**  
**2-3/8" (60 mm) Backset**  
**Passage Spring Latch**



- 3923**  
**2-3/4" (70 mm) Backset**  
**Privacy Spring Latch**

- 3926**  
**2-3/8" (60 mm) Backset**  
**Privacy Spring Latch**

### Optional Drive-In Dead Latches



- 3924**  
**2-3/4" (70 mm) Backset**  
**Dead Latch**
- For use with all keyed functions other than corridor

- 3927**  
**2-3/8" (60 mm) Backset**  
**Dead Latch**
- For use with all keyed functions other than corridor



- 3996**  
**2-3/8" (60 mm) Backset**  
**Dead Latch - Corridor Function Only**

- 3997**  
**2-3/4" (70 mm) Backset**  
**Dead Latch - Corridor Function Only**



## 3500 SERIES LATCHBOLTS

### Backset Extension Links



**3917**  
**3-3/4" (95 mm) Backset**  
**Extension Link**

Must use with 2-3/8" (60 mm) backset latch to achieve 3-3/4" total backset



**3937**  
**5" (127 mm) Backset**  
**Extension Link**

Must use with 2-3/4" (70 mm) backset latch to achieve 5" total backset



**3933**  
**T-Strike with Plastic Dust Box**  
• 1-1/8" x 2-3/4" (29 mm x 70 mm)  
• Dust box included



**3934**  
**Full Lip Strike**  
1-5/8" x 2-1/4" (41 mm x 57 mm)



**3935**  
**Standard ASA Strike Plate**  
• 1-1/4" x 4-7/8" (32 mm x 124 mm)  
• 1-5/16" lip  
• Other lengths available upon request



**3958**  
**Full Lip Strike with Round Corner**  
• 1-5/8" x 2-1/4" (41 mm x 57 mm)  
• 1/4" (6 mm) radius

### 3500 SERIES ACCESSORIES



**3959**  
**Faceplate Adapter**  
Converts 1" (25 mm) to 1-1/8" (28 mm) width



**3912**  
**Thru-Bolt Jig**  
For 3500 Series lever set only



# 3600 Series



Hager 3600 Series Grade 2 tubular lockset provides the necessary security and dependability of a commercial lock with a more residential look. It is well suited for medium duty commercial or heavy duty residential applications such as multi-family housing.







**3600 SERIES - HOW TO ORDER**

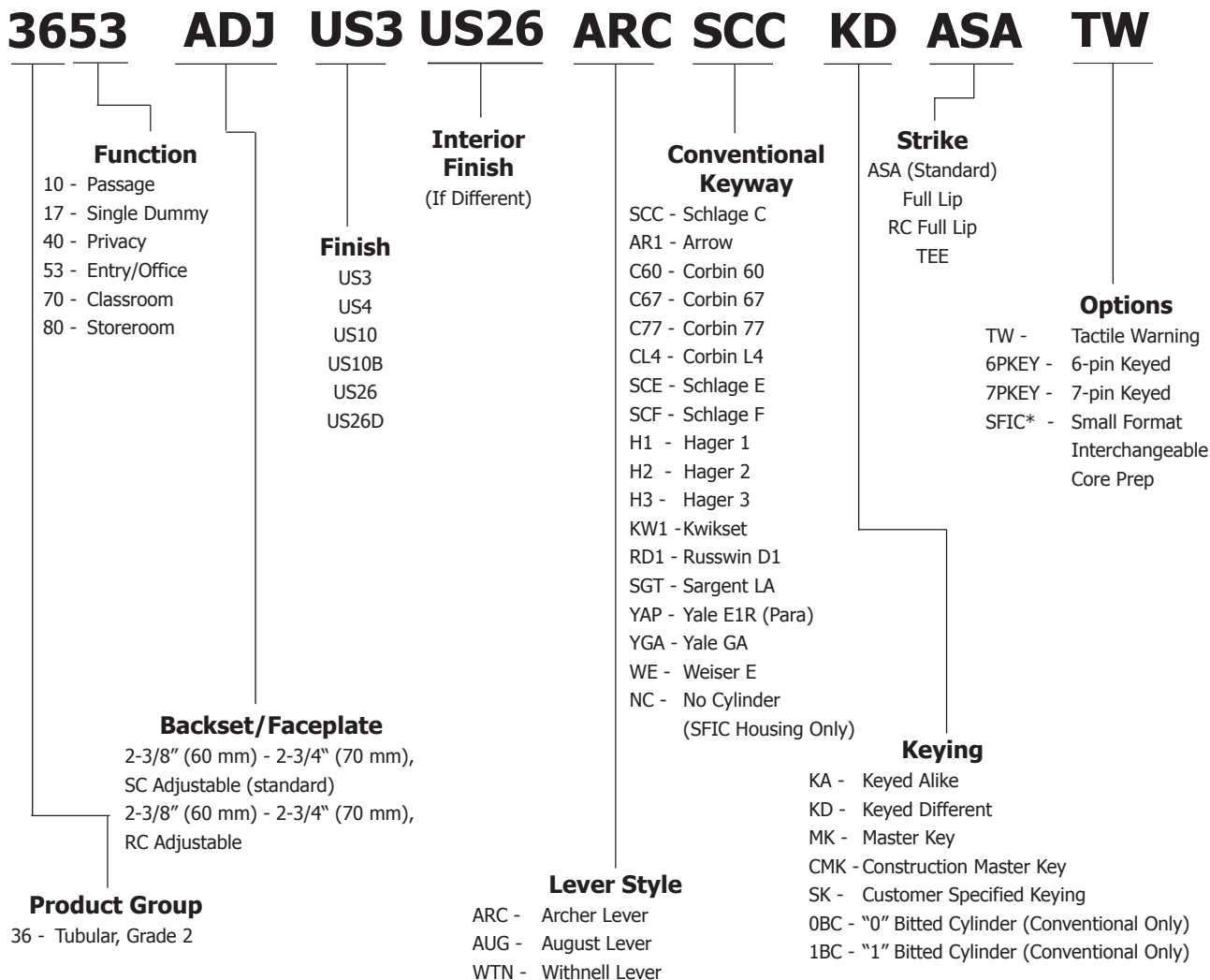

**Notes:**

1. If masterkeyed, include completed master key form with order (available on page 88 or [www.hagerco.com](http://www.hagerco.com)).
2. For additional keying information, please refer to cylinder, core, and keying section of catalog (page 73).







\* Small format interchangeable core sold separately. Available in Best Keyways (A Standard) or Hager Keyways (optional).

**Ordering example: 3653 ADJ 2-3/8" to 2-3/4" US26D WTN NC ASA SFIC**





## 3600 SERIES - FUNCTION CHART

Function	Function No.	Function Description	ANSI No.	
<b>Non-Keyed</b>				
	Passage	10	Latchbolt operated by lever from either side at all times.	F75
	Dummy - Single	17	Pull one side, no mechanical operation.	-
	Privacy	40	Latchbolt operated by lever from either side. Outside lever is locked by push button inside and unlocked by emergency release outside or operating inside lever.	F76B
<b>Keyed</b>				
	Entry/Office	53	Deadlocking latchbolt operated by lever from either side except when outside lever is locked by push button on inside. When outside lever is locked, operating key in outside lever unlocks locking device. Locking device shall automatically release when inside lever is operated. Closing door does not release push button.	F82A
	Classroom	70	Deadlocking latchbolt operated by lever from either side except when outside lever is locked from outside by key. When outside lever is locked, latchbolt is operated by inside lever.	F84
	Storeroom	80	Deadlocking latchbolt operated by key in outside lever, or by operating inside lever. Outside lever is always locked. Inside lever is always unlocked.	F86



**3600 SERIES - LEVER OPTIONS**

**ARCHER LEVER**

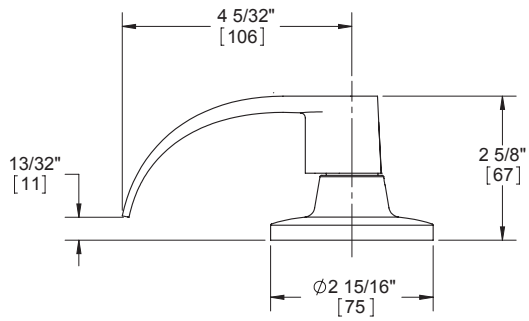

**AUGUST LEVER**

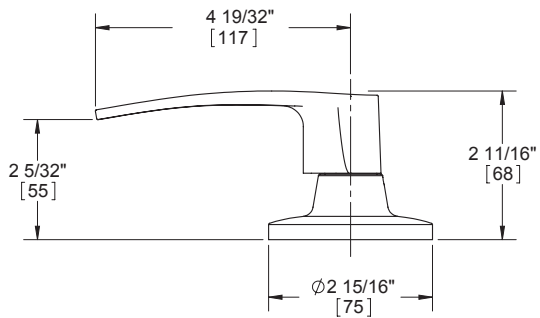

**WITHNELL LEVER**

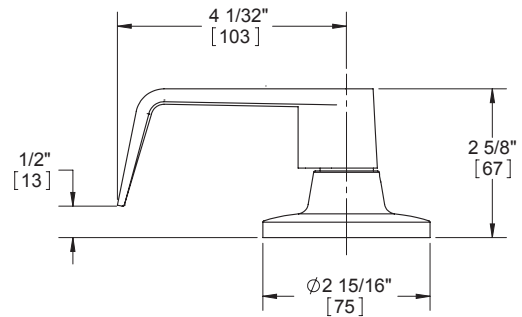

Notes: Optional tactile warning available on all lever styles (only outside lever will include raised surfaces unless otherwise specified).





## 3600 SERIES - GRADE 2 TUBULAR

<b>WARRANTY</b>	Five-year warranty
<b>FEATURES</b>	<ul style="list-style-type: none"> <li>• Heavy duty residential - medium duty commercial</li> <li>• No exposed mounting screws</li> <li>• Non-handed</li> <li>• Conventional cylinder or Small Format Interchangeable Core option available</li> </ul>
Certifications:	<ul style="list-style-type: none"> <li>• BHMA Certified ANSI A156.2 Series 4000 Grade 2</li> <li>• ADA Compliant ANSI A117.1 Accessibility Code</li> <li>• UL/cUL Listed for all functions up to 3 hours for "A" label single doors</li> <li>• UL10C Positive Pressure Rated</li> <li>• UL10B Neutral Pressure Rated</li> </ul>
Lever Options:	Archer, August, Withnell levers
Options:	<ul style="list-style-type: none"> <li>• Tactile warning</li> <li>• Split finish</li> </ul>
<b>SPECIFICATIONS</b>	
Standard Door Prep:	<ul style="list-style-type: none"> <li>• 2-1/8" (54 mm) diameter (bore)</li> <li>• Latch hole: 1" (25 mm) diameter (cross bore)</li> </ul>
Exposed Trim:	<ul style="list-style-type: none"> <li>• Levers: Cast zinc</li> <li>• Rose: Wrought brass</li> </ul>
Rose Diameter:	2-15/16" (75 mm)
Lock Chassis:	Heavy gauge steel, zinc dichromated
Keys:	Two operating keys supplied per lock
Cylinders/Cores:	<ul style="list-style-type: none"> <li>• Brass - keyed different - Schlage C Keyway - Standard</li> <li>• Cylinder drilled 6-pin, keyed 5-pin - Standard</li> <li>• Other keying options, including keyed 6-pin, available from factory (see cylinder, core and keying section)</li> <li>• Small Format Interchangeable Core option available</li> <li>• SFIC uncombined or combined, brass 6- or 7-pin cores sold separately</li> </ul>
Door Thickness:	1-3/8" - 1-3/4" (35 mm - 45 mm)
Backset:	<ul style="list-style-type: none"> <li>• Adjustable 2-3/8" - 2-3/4" (60 mm - 70 mm)</li> <li>• Preset at factory for 2-3/8" (60 mm)</li> </ul>
Latchbolt:	<ul style="list-style-type: none"> <li>• 1/2" (13 mm) throw, stainless steel</li> <li>• 1" x 2-1/4" (25 mm x 57 mm) faceplate</li> <li>• Square corner faceplate standard, round corner available</li> <li>• Deadlocking latchbolt prevents manipulation when door is closed; keyed functions only</li> </ul>
Strike:	3935 ASA 1-1/4" x 4-7/8" (32 mm x 124 mm) strike - Standard
Functions:	10 Passage, 17 Dummy, 40 Privacy, 53 Entry, 70 Classroom, 80 Storeroom
<b>FINISHES</b>	US3, US4, US10, US10B, US26, US26D





## 3600 SERIES LATCHBOLTS

### Adjustable Backset Spring Latches



**3951**  
2-3/8" (60 mm) - 2-3/4" (70 mm)  
**Adjustable Backset**  
**Spring Latch - Standard**

- Square corner
- 1" x 2-1/4" (25 mm x 57 mm) faceplate
- For use with Passage/Privacy functions



**3953**  
2-3/8" (60 mm) - 2-3/4" (70 mm)  
**Adjustable Backset**  
**Spring Latch**

- Round corner
- 1" x 2-1/4" (25 mm x 57 mm) faceplate
- For use with Passage/Privacy functions

### 5" Backset Spring Latches



**3939**  
5" (127 mm) **Backset**  
**Spring Latch**

- Square and round corner available
- 1" x 2-1/4" (25 mm x 57 mm) faceplate
- For use with Passage/Privacy functions

### Adjustable Backset Dead Latches



**3952**  
2-3/8" (60 mm) - 2-3/4" (70 mm)  
**Adjustable Backset**  
**Dead Latch - Standard**

- Square corner
- 1" x 2-1/4" (25 mm x 57 mm) faceplate
- For use with all keyed functions



**3954**  
2-3/8" (60 mm) - 2-3/4" (70 mm)  
**Adjustable Backset**  
**Dead Latch**

- Round corner
- 1" x 2-1/4" (25 mm x 57 mm) faceplate
- For use with all keyed functions

### 5" Backset Dead Latches



**3938**  
5" (127 mm) **Backset**  
**Dead Latch**

- Square and round corner available
- 1" x 2-1/4" (25 mm x 57 mm) faceplate
- For use with all keyed functions

### Optional Drive-In Latchbolts



**3914**  
2-3/8" (60 mm) - 2-3/4" (70 mm)  
**Adjustable Backset**  
**Spring Latch**

For use with Passage/Privacy functions



**3915**  
2-3/8" (60 mm) - 2-3/4" (70 mm)  
**Adjustable Backset**  
**Dead Latch**

For use with all keyed functions

### 3600 SERIES STRIKES



**3933**  
**T-Strike with Plastic Dust Box**

- 1-1/8" x 2-3/4" (29 mm x 70 mm)
- Dust box included



**3934**  
**Full Lip Strike**

1-5/8" x 2-1/4" (41 mm x 57 mm)



**3935**  
**ASA Strike - Standard**

- 1-1/4" x 4-7/8" (32 mm x 124 mm)
- 1-5/16" lip
- Other lengths available upon request



**3958**  
**Full Lip Strike with Round Corner**

- 1-5/8" x 2-1/4" (41 mm x 57 mm)
- 1/4" radius



**3959**  
**Faceplate Adapter**

- Converts 1" (25 mm) to 1-1/8" (28 mm) width
- Supplied standard with 3600 Series



# 3700 Series



Hager 3700 Series Grade 2 interconnected lock is a perfect match for residential or commercial applications such as apartment buildings and assisted living facilities. These versatile locks provide a single action for retracting the latchbolt and deadbolt simultaneously for panic-free egress. They are supplied with an optional exterior escutcheon plate standard and are backed by a lifetime warranty.

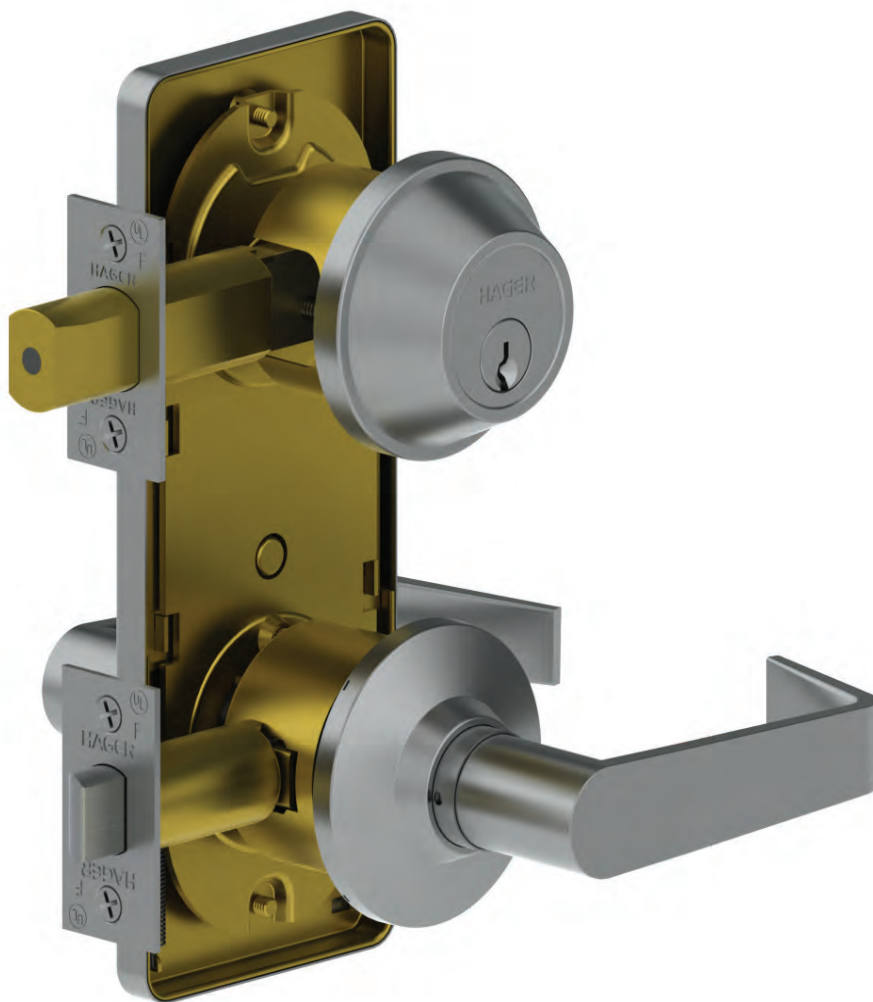



**3700 SERIES - HOW TO ORDER**

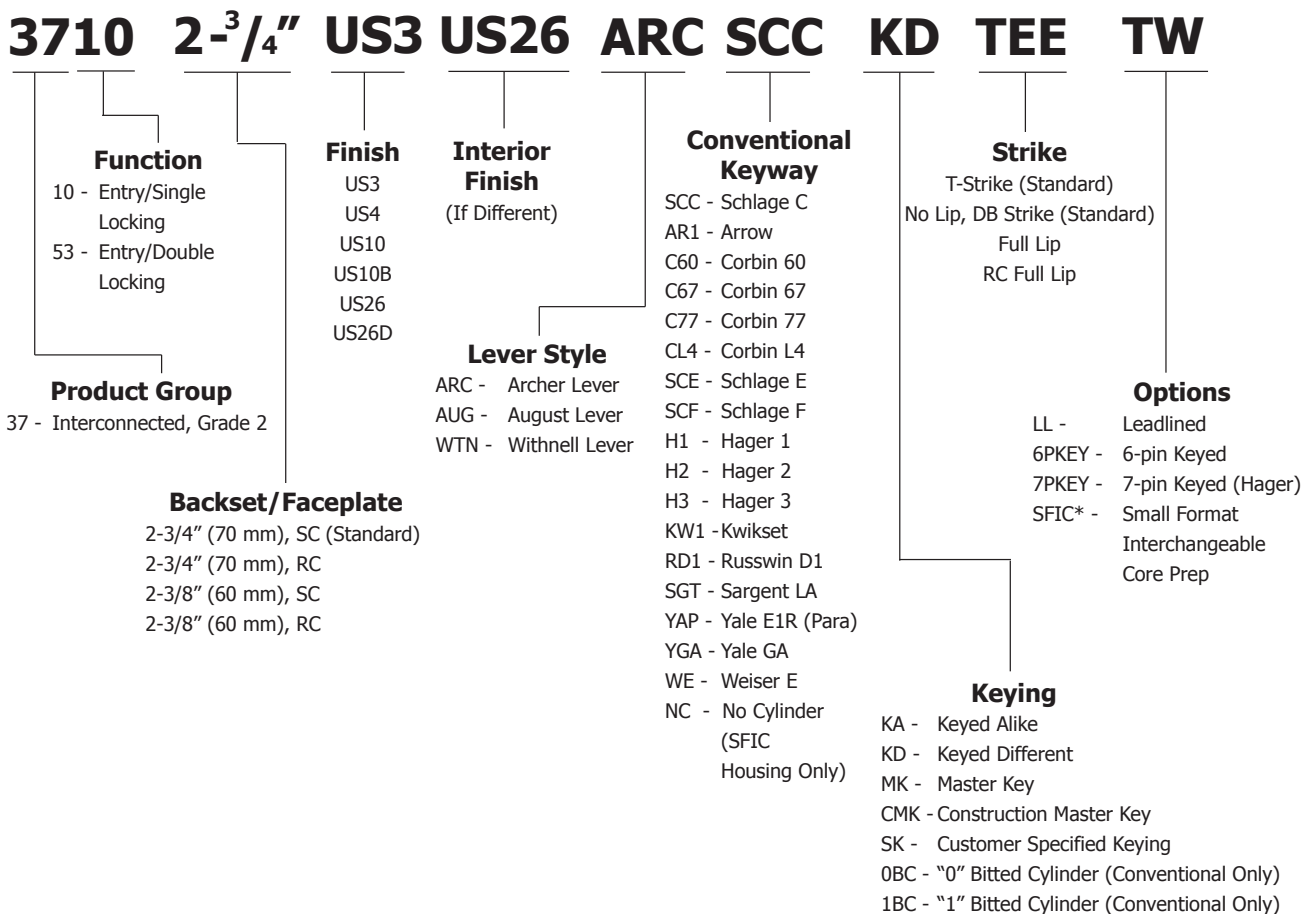



**Notes:**

1. If masterkeyed, include completed master key form with order (available on page 88 or www.hagerco.com).
2. For additional keying information, please refer to Cylinder, Core & Keying section of catalog (page 73).

\* Small format interchangeable core sold separately. Available in Best Keyways (A Standard) or Hager Keyways (optional).

**Ordering example: 3753 2-3/4" US26D WTN NC TEE SFIC**

**3700 SERIES FUNCTION CHART**

Function	Function No.	Function Description	ANSI No.	
<b>Interconnected</b>				
	Interconnected Single Locking Entry	10	Deadbolt thrown or retracted by key outside or by inside thumbturn. Bolt automatically deadlocks when fully thrown. Latchbolt retracted by lever from either side. Inside lever retracts deadbolt and latchbolt simultaneously for immediate exit.	F95
	Interconnected Double Locking Entry	53	Deadbolt thrown or retracted by key outside or by inside thumbturn. Bolt automatically deadlocks when fully thrown. Deadlatch retracted by key outside when locked by pushing turnbutton on inside lever. Outside lever may be fixed in locked position by rotating turnbutton. Inside lever retracts deadbolt and deadlatch simultaneously for immediate exit.	F97





**3700 SERIES - LEVER OPTIONS**

**ARCHER LEVER**

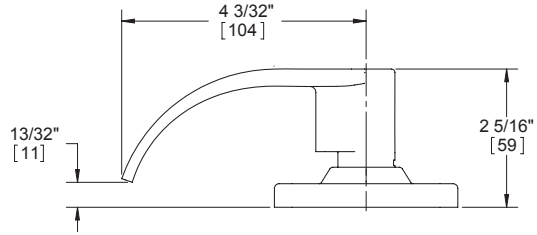

**AUGUST LEVER**

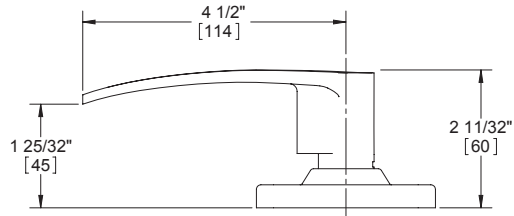

**WITHNELL LEVER**

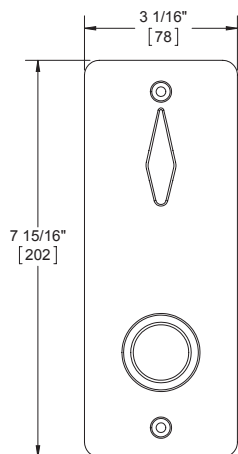
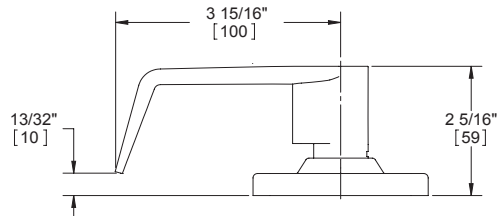
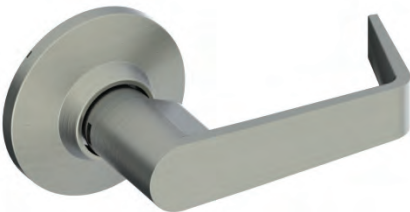

INSIDE ESCUTCHEON

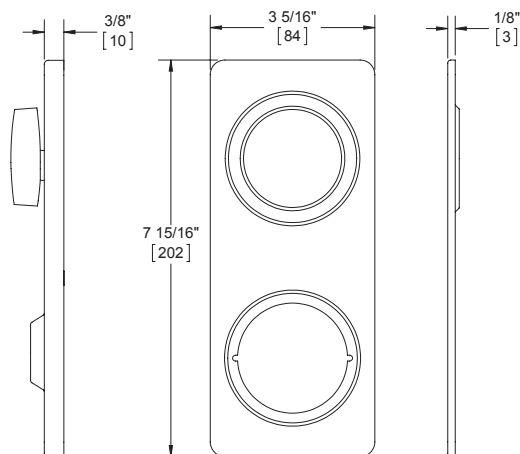

OPTIONAL OUTSIDE ESCUTCHEON





## 3700 SERIES - GRADE 2 INTERCONNECTED - MEDIUM DUTY COMMERCIAL

### WARRANTY

Lifetime warranty

### FEATURES

- Cylindrical chassis
- Non-handed
- Conventional cylinder or Small Format Interchangeable Core option available

### Certifications:

- BHMA Certified ANSI A156.12 Grade 2
- ADA Compliant ANSI A117.1 Accessibility Code
- UL/cUL Listed for all functions up to 3 hours for "A" label single doors
- UL10C Positive Pressure Rated
- UL10B Neutral Pressure Rated

### Lever Options:

Archer, August, Withnell levers

### Options:

- Split finish
- Split lever design

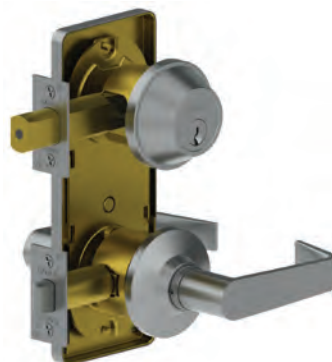

### SPECIFICATIONS

#### Standard Door

- 4" (102 mm) center of deadbolt to center of lock chassis
- 2-1/8" (54 mm) diameter (bore)

#### Prep:

- Latch hole: 1" (25 mm) diameter (cross bore)

#### Exposed Trim:

Wrought brass or bronze, cast zinc lever

#### Rose Diameter:

2-1/2" (63 mm)

#### Lock Chassis:

- Heavy gauge steel, zinc dichromated
- Thru-bolt mounting
- "Non-clutching" exterior lever

#### Outside Escutcheon:

3-5/16" x 7-15/16" x 3/8" (84 mm x 202 mm x 10 mm)

#### Inside Escutcheon:

3-1/16" x 7-15/16" x 1/8" (78 mm x 202 mm x 3 mm)

#### Keys:

Two operating keys supplied per lock

#### Cylinders/Cores:

- Brass - keyed different - Schlage C Keyway - Standard
- Cylinder drilled 6-pin, keyed 5-pin - Standard
- Other keying options, including keyed 6-pin, available from the factory (see cylinder, cores and keying section)
- Small Format Interchangeable Core option available
- SFIC uncombined or combined, brass 6- or 7-pin cores sold separately

#### Door Thickness:

- 1-3/8" - 1-3/4" (35 mm - 45 mm) - Standard
- 2" (52 mm) doors - Optional

#### Backsets:

- 2-3/4" (70 mm) - Standard
- 2-3/8" (60 mm) - Optional

#### Latchbolt:

- 1/2" (13 mm) Throw - stainless steel
- 1-1/8" x 2-1/4" (29 mm x 57 mm) faceplate for 2-3/4" (70 mm) backset
- 1" x 2-1/4" (25 mm x 57 mm) faceplate for 2-3/8" (60 mm) backset
- Deadlocking latchbolt prevents manipulation when door is closed; keyed functions only
- Square corner faceplate standard, round corner available

#### Deadbolt:

- 1" (25 mm) Throw - brass with concealed steel roller to prevent sawing or cutting
- 1-1/8" x 2-1/4" (29 mm x 57 mm) faceplate for 2-3/4" (70 mm) bracket
- 1" x 2-1/4" (25 mm x 57 mm) faceplate for 2-3/8" (60 mm) faceplate

#### Strikes:

- 3933 square corner t-strike with plastic dust box, 1-1/8" x 2-3/4" (29 mm x 70 mm) - Standard
- 3930 square corner strike plate with dust box, 1-1/8" x 2-3/4" (29 mm x 70 mm) - Standard

#### Functions:

- 10 Single Locking Entry
- 53 Double Locking Entry

### FINISHES

US3, US4, US10, US10B, US26, US26D





## 3700 SERIES - LATCHBOLTS

## 3700 SERIES STRIKES

### Spring Latches



**3947**  
**2-3/4" (70 mm) Backset**  
**Passage Spring Latch**  
 • Square and round corner available  
 • 1-1/8" x 2-1/4" (29 mm x 57 mm) faceplate



**3949**  
**2-3/8" (60 mm) Backset**  
**Passage Spring Latch**  
 • Square and round corner available  
 • 1" x 2-1/4" (25 mm x 57 mm) faceplate

### Dead Latches



**3948**  
**2-3/4" (70 mm) Backset**  
**Dead Latch - Standard**  
 • Square and round corner available  
 • 1-1/8" x 2-1/4" (29 mm x 57 mm) faceplate



**3950**  
**2-3/8" (60 mm) Backset**  
**Dead Latch**  
 • Square and round corner available  
 • 1" x 2-1/4" (25 mm x 57 mm) faceplate

### 3700 SERIES DEADBOLTS



**3920**  
**2-3/4" (70 mm) Backset**  
**Tapered Deadbolt - Standard**  
 • Square and round corner available  
 • 1-1/8" x 2-1/4" (29 mm x 57 mm) faceplate



**3921**  
**2-3/8" (60 mm) Backset**  
**Tapered Deadbolt**  
 • Square and round corner available  
 • 1" x 2-1/4" (25 mm x 57 mm) faceplate



**3930**  
**Strike Plate**  
 1-1/8" x 2-3/4" (29 mm x 70 mm)



**3933**  
**T-Strike with Plastic Dust Box**  
 1-1/8" x 2-3/4" (29 mm x 70 mm)



**3934**  
**Full Lip Strike**  
 1-5/8" x 2-1/4" (41 mm x 57 mm)



**3958**  
**Round Corner Full Lip Strike**  
 • 1-5/8" x 2-1/4" (41 mm x 57 mm)  
 • 1/4" (6 mm) radius



**3959**  
**Faceplate Adapter**  
 Converts 1" (25 mm) to 1-1/8" (28 mm) width



# 3800 Series



Hager 3800 Series mortise lock provides maximum security and durability for the harshest environments. With field reversible handing, ease of installation, and both escutcheon and sectional models available, our 3800 Series lock provides great flexibility. What's more, it is ANSI certified Grade 1 Operational and Security and is backed by a lifetime warranty.

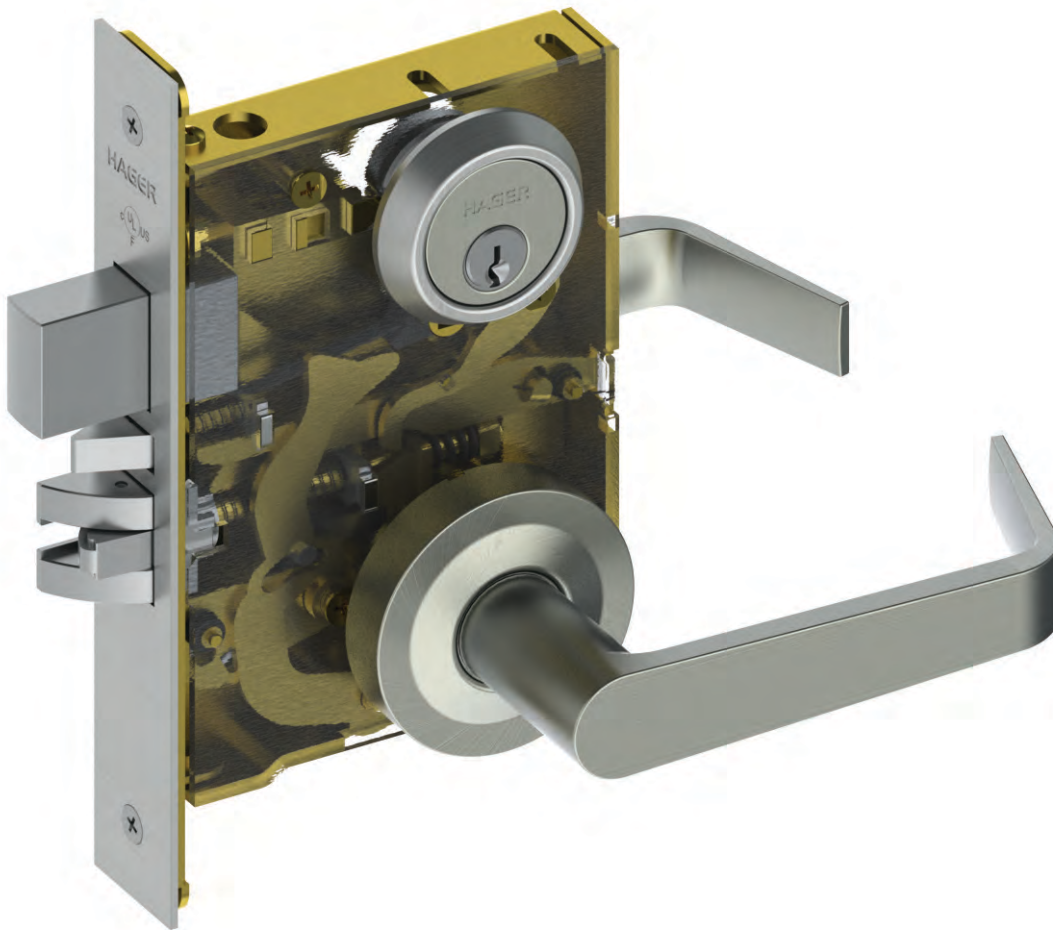



# 3800 SERIES - ESCUTCHEON & SECTIONAL MORTISE LOCKS - HOW TO ORDER

## 3853 ESC US3 US26 ARC Full6 SCC KD 0 0 0 TW

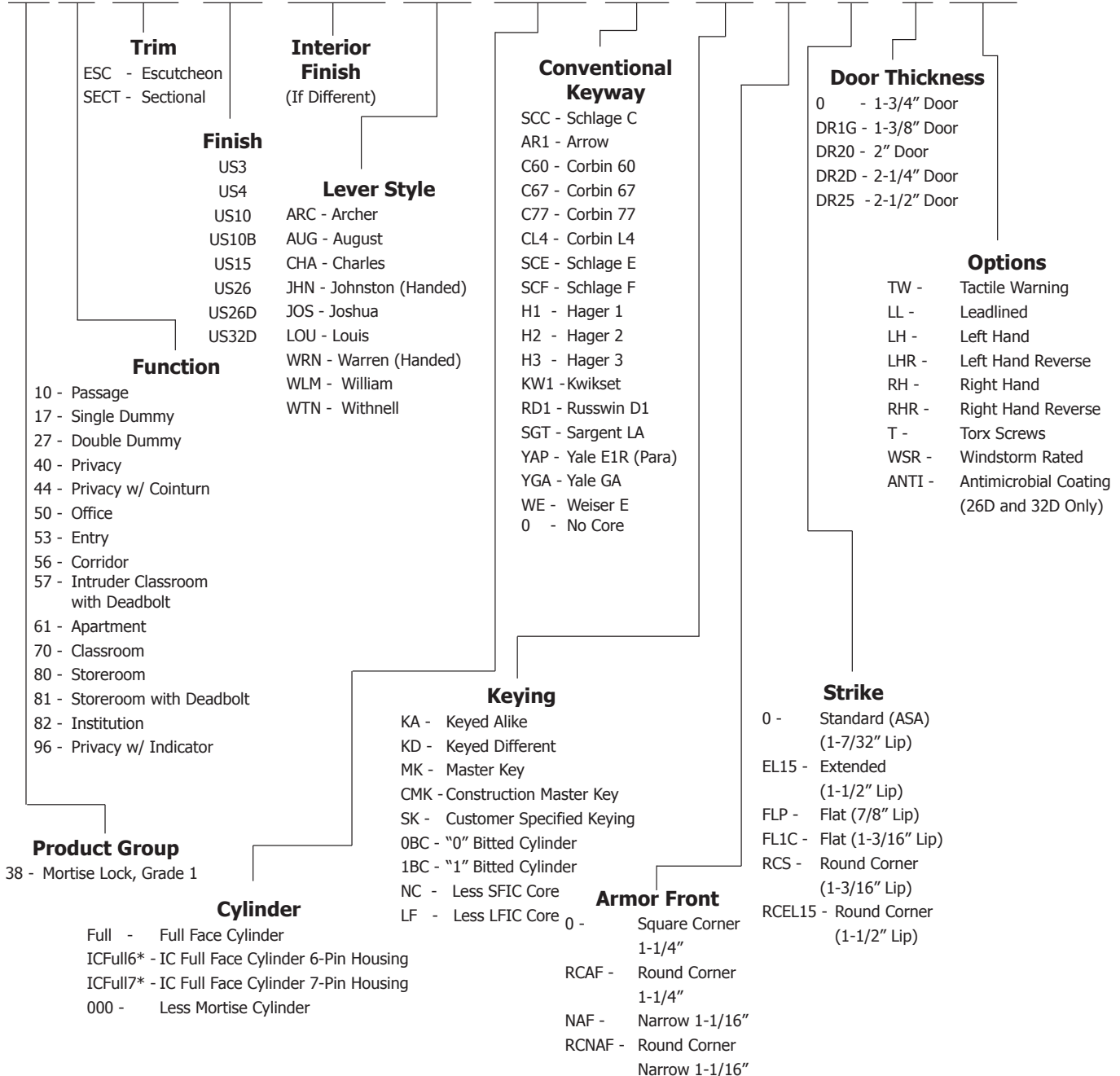

**Notes:**

- Finishes other than US10B, US15, US26D and US32D will be subject to extended lead times.
- If masterkeyed, include completed master key form with order (available on page 88 or www.hageco.com).
- For additional keying information, refer to cylinder, core, and keying section of catalog (page 73).
- Quick Connect option available on 3800 Series Electrified Sectional and Escutcheon models (EL, EU, RX, DPM, and LM).

**Ordering example: 3880 SECT US26D WTN EU24QC**

\* Small format interchangeable core sold separately. Available in Best Keyways (A Standard), Hager Keyways (optional).

\* Large format interchangeable core sold separately. Available in Schlage C Keyway only.

**Ordering example: • 3850 ESC 26D WTN ICFULL6 NC  
• 3850 ESC 26D WTN ICFULL6 LF**





## 3800 SERIES - MORTISE DEADLOCKS - HOW TO ORDER

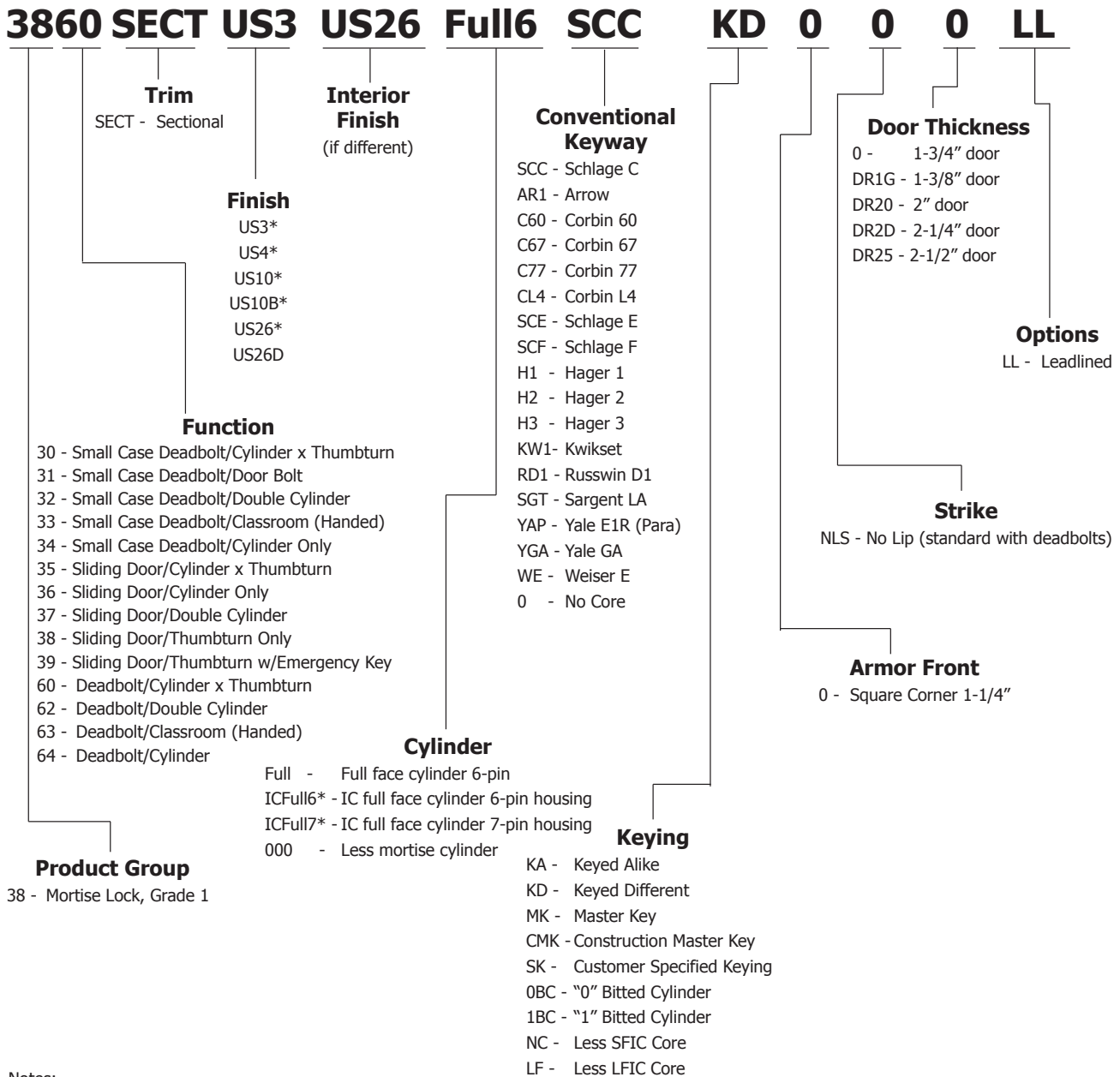

**Notes:**

- Finishes other than US26D may require extended lead times.
- If masterkeyed, include completed master key form with order (available on page 88 or [www.hagerco.com](http://www.hagerco.com)).
- For additional keying information, refer to cylinder, core, and keying section of catalog (page 73).

\* Small format interchangeable core sold separately. Available in Best Keyways (A standard), or Hager Keyways (optional).

\* Large format interchangeable core sold separately. Available in Schlage C Keyway only.

**Ordering example:** • 3860 SECT 26D ICFULL6 NC  
• 3860 SECT 26D ICFULL6 LF





## 3800 SERIES - ESCUTCHEON AND SECTIONAL LOCK FUNCTION CHART

Function	Function No.	Function Description	ANSI No.	
<b>Keyed Without Deadbolt</b>				
	Office	50	Latchbolt retracted by lever from either side unless outside is made inoperative by key outside or by turning inside thumbturn. When outside is locked, latchbolt is retracted by lever inside. Outside lever remains locked until thumbturn is returned to vertical or unlocked by key. Auxiliary latch deadlocks latchbolt when door is closed.	F04
	Apartment Entrance	61	Latchbolt retracted by lever from either side unless outside is locked by key from inside. When locked, latchbolt retracted by key outside or lever inside. Auxiliary latch deadlocks when door is closed.	F09
	Classroom	70	Latchbolt retracted by lever from either side unless outside is locked by key. Unlocked from outside by key. Inside lever always free for immediate exit. Auxiliary latch deadlocks latchbolt when door is closed.	F05
	Storeroom	80	Latchbolt retracted by key outside or by lever inside. Outside lever always inoperative. Inside lever always free for immediate exit. Auxiliary latch deadlocks latchbolt when door is closed.	F07
	Institution	82	Latchbolt retracted by key from either side. Lever on both sides always inoperative. Auxiliary latch deadlocks latchbolt when door is closed.	F30
<b>Keyed With Deadbolt</b>				
	Entry	53	Latchbolt retracted by lever from either side unless outside is locked by 20° rotation of thumbturn. Deadbolt thrown or retracted by 90° rotation of thumbturn. When locked, key outside or lever inside retracts deadbolt and latchbolt simultaneously. Outside lever remains locked until thumbturn is restored to vertical position. Throwing deadbolt automatically locks outside lever. Auxiliary latch deadlocks latchbolt when door is closed.	F20
	Corridor	56	Latchbolt retracted by lever from either side. Deadbolt thrown or retracted by key outside or thumbturn side. Throwing deadbolt locks outside lever. Turning inside lever simultaneously retracts deadbolt and latchbolt and unlocks the outside lever.	F13
	Intruder Classroom w/ Deadbolt	57	Latchbolt retracted by lever from either side. Deadbolt thrown or retracted by key from either side. Throwing deadbolt locks outside lever. Turning inside lever simultaneously retracts deadbolt and latchbolt and unlocks outside lever.	F33
	Storeroom w/ Deadbolt	81	Latchbolt retracted by key outside or by lever inside. Outside lever always fixed. Deadbolt thrown or retracted by key outside or thumbturn inside. Turning inside lever simultaneously retracts deadbolt and latchbolt. Auxiliary latch deadlocks latchbolt when door is closed.	-
<b>Non-Keyed Without Deadbolt</b>				
	Passage	10	Latchbolt retracted by lever from either side at all times.	F01
	Privacy	40	Latchbolt retracted by lever from either side unless outside is locked by inside thumbturn. Turning inside lever or closing door unlocks outside lever. To unlock from outside, remove emergency button, insert emergency turn (furnished) in access hole and rotate.	F22
	Privacy with Cointurn	44	Latchbolt retracted by lever from either side unless outside is locked by inside thumbturn or outside cointurn. Operating inside lever, closing door, rotating inside thumbturn, or rotating outside cointurn unlocks outside lever.	-















## 3800 SERIES - ESCUTCHEON AND SECTIONAL LOCK FUNCTION CHART

Function	Function No.	Function Description	ANSI No.	
<b>Non-Keyed Without Deadbolt</b>				
	Privacy with Indicator	96	Latchbolt retracted by lever from either side. Turning inside thumbturn locks outside lever and displays "Occupied." Operating inside lever, closing door, rotating inside thumbturn. To unlock from outside, remove emergency button, insert emergency turn (furnished) in access hole and rotate.	-
<b>Non-Keyed Dummy</b>				
	Single Dummy	17	Pull one side. No mechanical operation.	-
	Double Dummy	27	Pull both sides. No mechanical operation (back to back).	-





## 3800 SERIES DEADLOCK FUNCTION CHART

Function	Function No.	Function Description	ANSI No.	
	Cylinder x Thumbturn (Small Case)	30	Deadbolt operated by key from outside and by thumbturn from inside.	E06071
	Door Bolt (Small Case)	31	Deadbolt operated by thumbturn from one side only. No trim on other side.	E06181
	Double Cylinder Lock (Small Case)	32	Deadbolt operated by key from either side.	E06061
	Classroom (Small Case)	33	Deadbolt operated by key from outside. Cylinder turn from inside retracts but does not project deadbolt.	E06091
	Cylinder Only (Small Case)	34	Deadbolt operated by key from one side only.	E06081
	Cylinder x Thumbturn (Sliding Door)	35	Deadbolt operated by key from outside and by thumbturn from inside.	-
	Cylinder Only (Sliding Door)	36	Deadbolt operated by key from one side only.	-
	Double Cylinder Lock (Sliding Door)	37	Deadbolt operated by key from either side.	-
	Thumbturn Only (Sliding Door)	38	Deadbolt operated by thumbturn from one side only.	-
	Thumbturn w/ Emergency Key (Sliding Door)	39	Deadbolt operated by thumbturn from inside. To unlock from outside, remove emergency button, insert emergency key (furnished) in access hole and rotate.	-





## 3800 SERIES - ESCUTCHEON AND SECTIONAL LOCK FUNCTION CHART

Function	Function No.	Function Description	ANSI No.
 Cylinder x Thumbturn (Full Case)	60	Deadbolt thrown or retracted by key outside or thumbturn inside.	F17
 Double Cylinder (Full Case)	62	Deadbolt operated by key from either side.	F16
 Classroom (Full Case)	63	Deadbolt thrown or retracted by key from outside. Inside thumbturn cylinder retracts deadbolt but cannot project it.	F29
 Cylinder (Full Case)	64	Deadbolt thrown or retracted by key from one side. No trim on opposite side.	F18



**3800 SERIES - ESCUTCHEON - STANDARD LEVER OPTIONS**

**ARCHER LEVER**

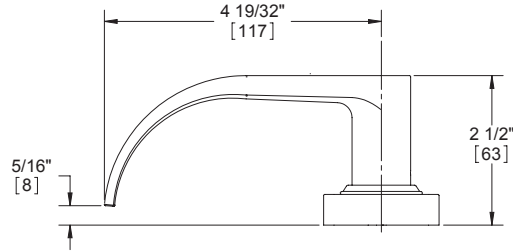

**AUGUST LEVER**

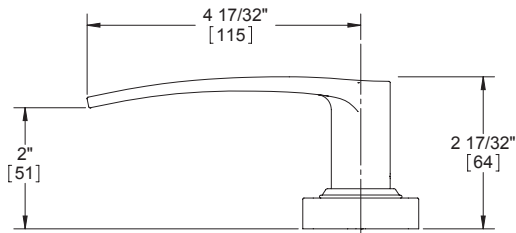

**WILLIAM LEVER**

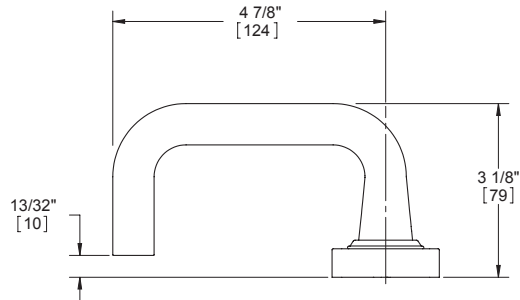

**WITHNELL LEVER**

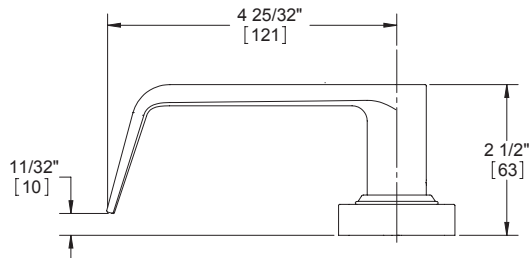

Optional tactile warning available on all lever styles (only outside lever will include raised surfaces unless otherwise specified).



## 3800 SERIES - ESCUTCHEON - DECORATIVE LEVER OPTIONS

### CHARLES LEVER

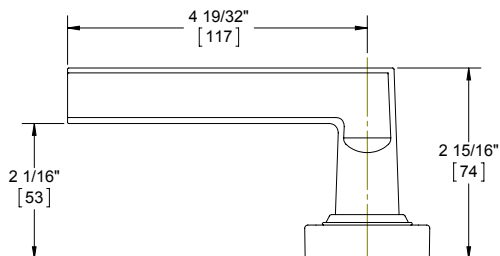

### JOHNSTON LEVER

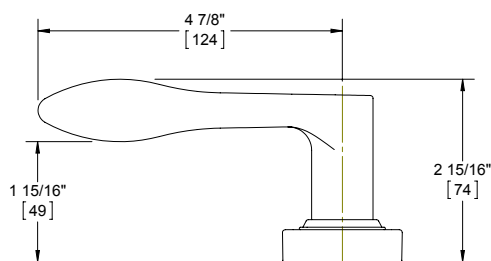

### JOSHUA LEVER

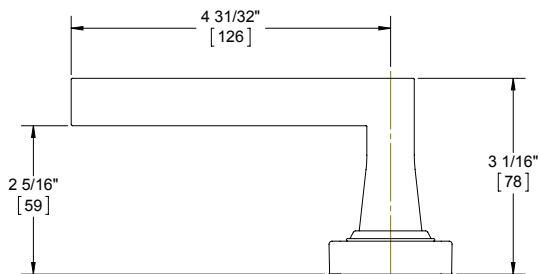

### LOUIS LEVER

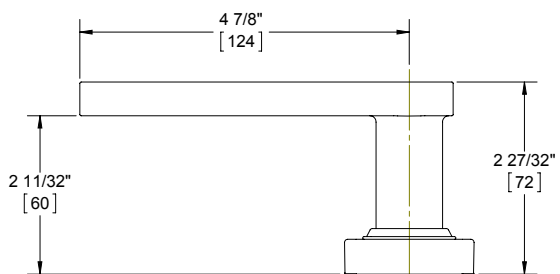

### WARREN LEVER

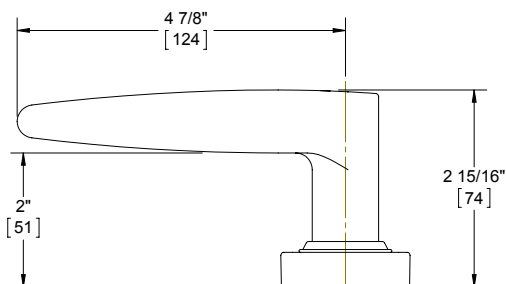



**3800 SERIES - SECTIONAL - STANDARD LEVER OPTIONS**

**ARCHER LEVER**

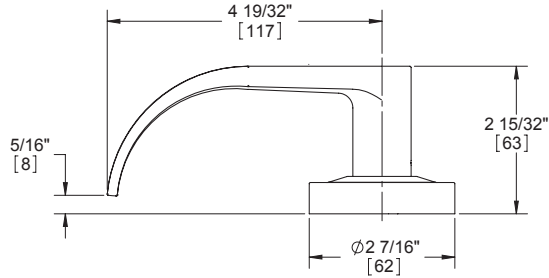

**AUGUST LEVER**

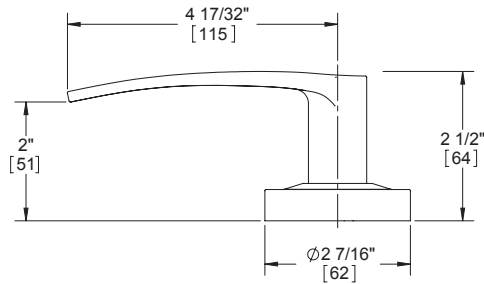

**WILLIAM LEVER**

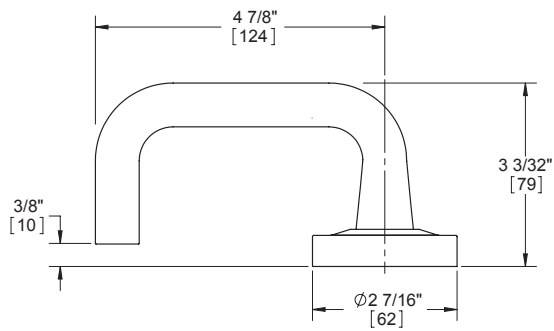

**WITHNELL LEVER**

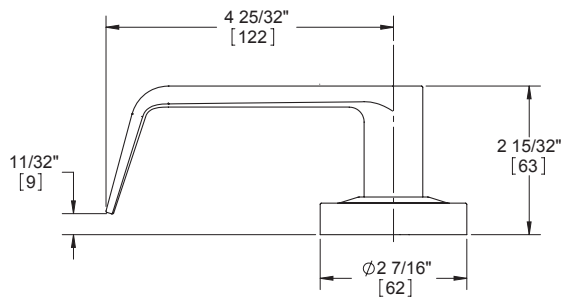

Optional tactile warning available on all lever styles (only outside lever will include raised surfaces unless otherwise specified).



**3800 SERIES - SECTIONAL - DECORATIVE LEVER OPTIONS**

**CHARLES LEVER**



**JOHNSTON LEVER**



**JOSHUA LEVER**



**LOUIS LEVER**



**WARREN LEVER**

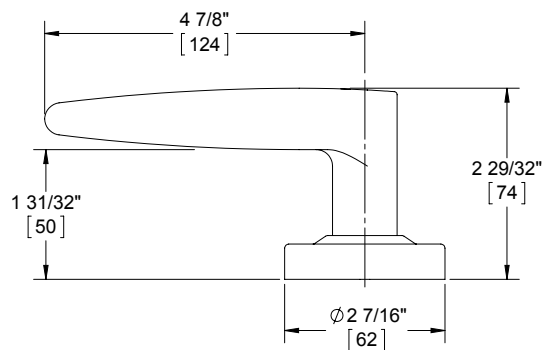
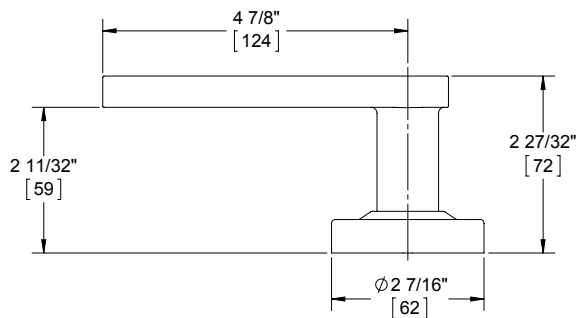
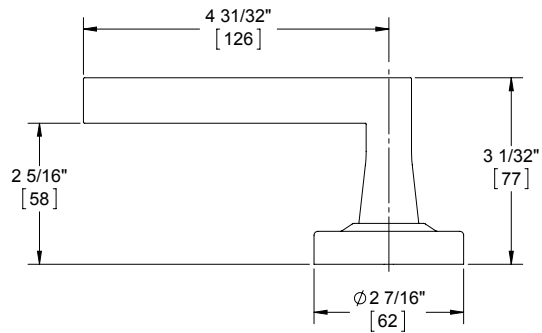
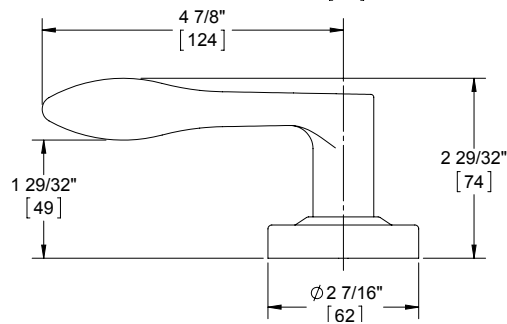
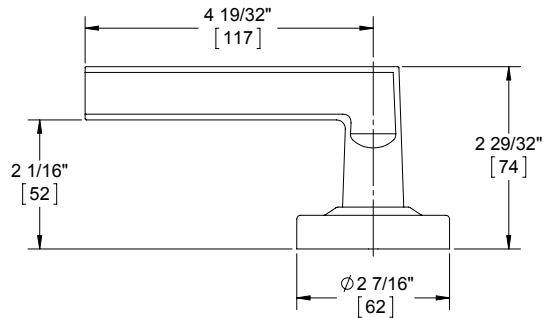



## 3800 SERIES - GRADE 1 MORTISE (ESCUTCHEON) - HEAVY DUTY

### WARRANTY

Lifetime warranty

### FEATURES

- Heavy duty commercial, industrial, institutional
- Concealed thru-bolts
- Lock body handing is field reversible (default from the factory is Left Hand Reverse)
- Conventional mortise cylinder, Small Format Interchangeable Core, or Large Format Interchangeable Core option available
- BHMA Certified Grade 1 Security with standard mortise cylinder

### Certifications:

- BHMA Certified ANSI A156.13 Grade 1 Series 1000 Operational and Security
- ADA Compliant ANSI A117.1 Accessibility Code
- UL/cUL Listed for all functions up to 3 hours for "A" label doors
- UL10C Positive Pressure Rated
- UL10B Neutral Pressure Rated
- A250.13 Severe Windstorm Resistant (only available in **53 and 81** Functions)

### Lever Options:

Archer, August, Charles, Johnston (handed), Joshua, Louis, Warren (handed), William, Withnell levers

### Options:

- Tactile warning
- Lead lining
- Split finish
- Antimicrobial coating (26D and 32D only)
- Factory handing available if specified



### SPECIFICATIONS

#### Standard Door

- 3-5/8" (92 mm) center of cylinder to spindle
- 2-7/16" (62 mm) center of thumbturn to spindle

#### Exposed Trim:

Cast zinc - Standard

#### Lock Case:

4-5/16" x 6" x 1" (110 mm x 152 mm x 25 mm)

#### Armor Front:

1-1/4" x 8" x 7/32" (32 mm x 203 mm x 5 mm) - Standard

#### Escutcheon:

1-15/16" x 8" (50 mm x 203 mm)

#### Keys:

Two operating keys supplied per lock

#### Cylinders/Cores:

- Brass - keyed different - Schlage C Keyway
- Cylinder drilled 6-pin, keyed 5-pin - Standard
- Other keying options, including keyed 6-pin, available from factory
- Large Format Interchangeable Core cylinder option available
- LFIC core available zero bitted or combined, brass 6-pin cores sold separately
- Small Format Interchangeable Core cylinder option available
- SFIC uncombined or combined, brass 6- or 7-pin cores sold separately
- Schlage "L" cam - Standard
- For function 61, ext cylinders, use standard cam

#### Door Thickness:

- 1-3/4" - 2-1/2" (45 mm - 64 mm)
- Privacy functions have a max door thickness of 2" (51 mm)
- Must specify door thickness if greater than 1-3/4" (45 mm)

#### Backset:

2-3/4" (70 mm) only

#### Latchbolt:

3/4" (19 mm) throw with anti-friction tongue, all stainless steel

#### Deadbolt:

1" (25 mm) throw - stainless steel

#### Strike:

3985 1-1/4" x 4-7/8" (32 mm x 124 mm), 1-7/32" (31 mm) lip - Standard

#### Fasteners:

Thru-bolted trim concealed under escutcheon

#### Functions:

10 Passage, 17 Dummy, 27 Double Dummy, 40 Privacy, 44 Privacy with Cointurn, 50 Office, 53 Entry, 56 Corridor, 57 Intruder Classroom with Deadbolt, 61 Apartment, 70 Classroom, 80 Storeroom, 81 Storeroom with Deadbolt, 82 Institution, 96 Privacy with Indicator

#### Notes:

- Self-adjusting case for beveled doors or square edge doors
- Stopworks are incorporated in thumbturn
- Non-handed, stainless steel, deadlocking latchbolt

### FINISHES

- US3, US4, US10, US10B, US15, US26, US26D, US32D
- US3, US4, US10 and US26 may be subject to extended lead times





## 3800 SERIES - GRADE 1 MORTISE (SECTIONAL) - HEAVY DUTY

### WARRANTY

Lifetime warranty

### FEATURES

- Heavy duty commercial, industrial, institutional
- Concealed thru-bolts
- Lock body handing is field reversible (default from the factory is Left Handed Reverse)
- Conventional mortise cylinder, Small Format Interchangeable Core, or Large Format Interchangeable Core option available
- BHMA Certified Grade 1 Security with standard mortise cylinder

### Certifications:

- BHMA Certified ANSI A156.13 Series 1000 Grade 1 Operational and Security
- ADA Compliant ANSI A117.1 Accessibility Code
- UL/cUL Listed for all functions up to 3 hours for "A" label doors
- UL10C Positive Pressure Rated
- UL10B Neutral Pressure Rated
- A250.13 Severe Windstorm Resistant (only available in **53 and 81** Functions)

### Lever Options:

Archer, August, Charles, Johnston (handed), Joshua, Louis, Warren (handed), William, Withnell levers

### Options:

- Tactile warning
- Lead lining
- Split finish
- Antimicrobial coating (26D and 32D only)
- Factory handing available if specified



### SPECIFICATIONS

#### Standard Door

- 3-5/8" (92 mm) center of cylinder to spindle
- 2-7/16" (62 mm) center of thumbturn to spindle

#### Exposed Trim:

Cast zinc - Standard

#### Lock Case:

4-5/16" x 6" x 1" (110 mm x 152 mm x 25 mm)

#### Armor Front:

1-1/4" x 8" x 7/32" (32 mm x 203 mm x 5 mm) - Standard

#### Rose Diameter:

2-7/16" (62 mm)

#### Keys:

Two operating keys supplied per lock

#### Cylinders/Cores:

- Brass - keyed different - Schlage C Keyway
- Cylinder drilled 6-pin, keyed 5-pin - Standard
- Other keying options, including keyed 6-pin, available from factory
- Large Format Interchangeable Core cylinder option available
- LFIC core available zero bitted or combined, brass 6-pin cores sold separately
- Small Format Interchangeable Core cylinder option available
- SFIC uncombined or combined, brass 6- or 7-pin cores sold separately
- Schlage "L" Cam - Standard
- For Function 61, Ext Cylinders, use Standard Cam

#### Door Thickness:

- 1-3/4" - 2-1/2" (45 mm - 64 mm)
- Privacy functions have a max door thickness of 2" (51 mm)
- Must specify door thickness if greater than 1-3/4" (45 mm)

#### Backset:

2-3/4" (70 mm) only

#### Latchbolt:

3/4" (19 mm) throw with anti-friction tongue, all stainless steel

#### Deadbolt:

1" (25 mm) throw - stainless steel

#### Strike:

3985 1-1/4" x 4-7/8" (32 mm x 124 mm), 1-7/32" (31 mm) lip - standard

#### Fasteners:

Thru-bolted trim concealed under rose

#### Functions:

10 Passage, 17 Dummy, 27 Double Dummy, 40 Privacy, 44 Privacy with Cointurn, 50 Office, 53 Entry, 56 Corridor, 57 Intruder Classroom with Deadbolt, 61 Apartment, 70 Classroom, 80 Storeroom, 81 Storeroom with Deadbolt, 82 Institution, 96 Privacy with Indicator

#### Notes:

- Self-adjusting case for beveled doors or square edge doors
- Stopworks are incorporated in thumbturn
- Non-handed, stainless steel, deadlocking latchbolt

### FINISHES

- US3, US4, US10, US10B, US15, US26, US26D, US32D
- US3, US4, US10 and US26 may be subject to extended lead time





## 3800 SERIES - ELECTRIFIED - GRADE 1 MORTISE - HEAVY DUTY

### WARRANTY

- Lifetime warranty on mechanical locking components
- One-year warranty on electric components

### FEATURES

- Deadlocking latch
- Key override allows latchbolt to be momentarily retracted with the key even though electrically locked. Note that locks that are electrically unlocked may not be locked via the key cylinder.
- Inside lever always allows egress
- Interface with life-safety systems
- Continuous-duty solenoids

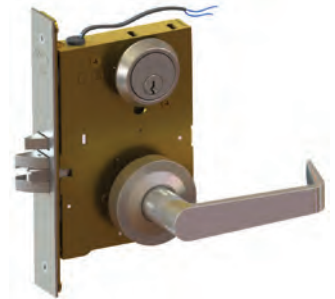

### Function:

- 80 - Storeroom
- 82 - Institutional

### Applications:

- Provides remote locking and unlocking ideal for door control where added security is necessary
- Stairtower doors
- Office doors
- Classrooms
- Elevator lobby doors
- Computer rooms
- Hospital equipment rooms
- Pharmaceutical storage rooms

### Voltage:

- 12V AC/DC; current - .612AMP
- 24V AC/DC; current - .330AMP
- Specify 12V or 24V when ordering

### Quick Connect:

Available option on EL, EU, RX, DPM, and LM. Compatible with Hager Quick Connect Harness Cable which can plug into Hager Hinges with Quick Connects for quick and accurate wiring of the door.

### FINISHES

- US3, US4, US10, US10B, US15, US26, US26D, US32D
- US3, US4, US10 and US26 may be subject to extended lead time

Function	Function No.	Function Description
Storeroom - Fail Safe	3880EL	Outside lever continuously locked electrically. Latchbolt operable from the outside by key, by breaking electric current, or by power failure. Auxiliary latch deadlocks latchbolt when door is closed. Inside always free for immediate egress.
Storeroom - Fail Secure	3880EU	Outside lever continuously locked. Latchbolt operable from the outside by key or by applying electrical current. Auxiliary latch deadlocks latchbolt when door is closed. Inside always free for immediate egress.
Institution - Fail Safe	3882EL	Both levers continuously locked electrically. Latchbolt operable by key, by breaking electric current, or by power failure. Auxiliary latch deadlocks latchbolt when door is closed.
Institution - Fail Secure	3882EU	Both levers continuously locked. Latchbolt operable by key or by applying electrical current. Auxiliary latch deadlocks latchbolt when door is closed.
Request to Exit	RX	Monitors inside lever rotation. Incorporates into fire alarm systems or in conjunction with an electromagnet. Available on 3880 or in combination with 3880EL/3880EU.
Latchbolt Monitor	LM	A single switch (SPDT) mounted inside lockset monitors the full extension of the latchbolt. Available on 3880 or in combination with 3880EL/3880EU.
Door Position Monitor	DPM	A single switch (SPDT Reed Magnetic Switch) mounted inside lockset monitors whether the door is fully closed. Available on 3880, 3882, or in combination with 3880EL/3880EU or 3882EL/3882EU.



## 3800 SERIES - POWER SUPPLIES

See power supply area within the Electrified Products section for more details on our full selection of power supplies. Hager 2903, 2908 and 2909 power supplies are designed to power locking devices. Their features include:

- UL Listed
- Filtered/regulated 24VDC
- Overload protection
- Over voltage protection
- Short circuit protection
- Surge suppression on Fail Safe and Fail Secure outputs
- Fire alarm input standard

### 2903 Power Supply Includes:

- 24VDC, 2Amp
- Automatically accepts 120 or 240VAC input
- Auxiliary 24VDC output for stand alone devices
- Switch 24VDC outputs for fail safe or fail secure locking hardware
- Surge suppression on Fail Safe and Fail Secure outputs

### 2908 Power Supply Includes:

- Field selectable 12VDC or 24VDC, 1Amp
- 115VAC standard (230VAC optional)
- Separate PTC protected charging for battery backup
- LED status indicator
- Modular design allows optional components to fit any application (see Electrified Catalog for a full list of components)

### 2909 Power Supply Includes:

- Field selectable 12VDC or 24VDC, 2Amp
- 115VAC standard (230VAC optional)
- Separate PTC protected charging for battery backup
- LED status indicator
- Modular design allows optional components to fit any application (see Electrified Catalog for a full list of components)

## Hager Locking System

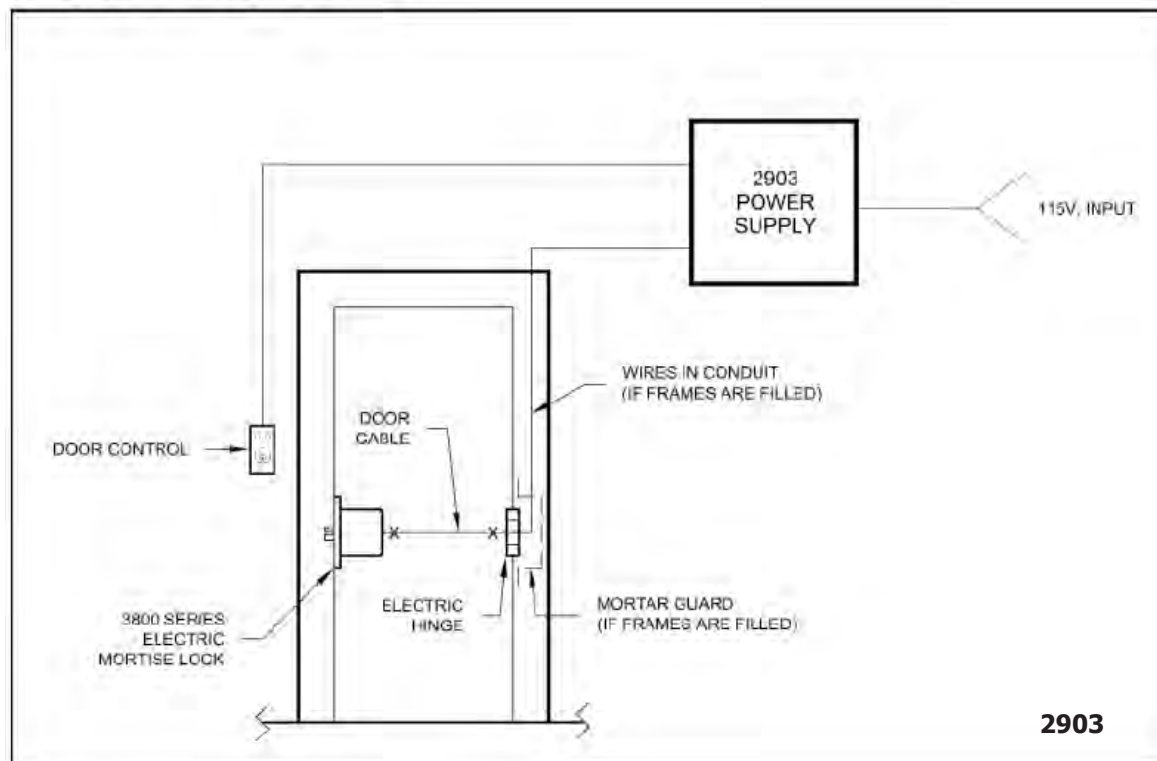



## 3800 SERIES - STRIKES

## 3800 SERIES - MORTISE CYLINDERS



### 3985

#### Standard Lip Strike

- Square corner
- 1-1/4" x 4-7/8" x 1-7/32" lip  
(32 mm x 124 mm x 31 mm)



### 3986

#### Extended Lip Strike

- Square corner
- 1-1/4" x 4-7/8" x 1-1/2" lip  
(32 mm x 124 mm x 30 mm)



### 3987

#### Standard Lip Strike

- Round corner
- 1-1/4" x 4-7/8" x 1-7/32" lip  
(32 mm x 124 mm x 31 mm)



### 3988

#### Extended Lip Strike

- Round corner
- 1-1/4" x 4-7/8" x 1-1/2" lip  
(32 mm x 124 mm x 38 mm)



### 3989

#### Flat Lip Strike

- Square corner
- 1-1/4" x 4-7/8" x 7/8" lip  
(32 mm x 124 mm x 22 mm)



### 3990

#### Extended Flat Lip Strike

- Square corner
- 1-1/4" x 4-7/8" x 1-7/32" lip  
(32 mm x 124 mm x 31 mm)



### 3902

#### Mortise Cylinder

- If cylinder is ordered separately from the mortise lock, please specify Schlage "L" Cam; **For 61 Function, specify Standard Cam and "L" Cam**
- Available in Conventional, Small Format Interchangeable Core, and Large Format Interchangeable Core (6-pin only)
- SFIC core sold separately
- LFIC core sold separately
- Conventional cylinder available in 1-1/8" (29 mm) and 1-1/4" (32 mm)
- SFIC cylinder available in 1-1/4" (32 mm) and 1-3/8" (35 mm) length
- LFIC cylinder available in 1-1/2" (38 mm) length
- For more cylinder information, please refer to Cylinder, Core, and Keying section.



## 3800 SERIES - GRADE 1 MORTISE DEADLOCK - HEAVY DUTY

**WARRANTY**

Lifetime warranty

**FEATURES**

- Heavy duty commercial, industrial, institutional
- Non-handed (except for 63 Classroom Function)
- Conventional mortise cylinder, Small Format Interchangeable Core or Large Format Interchangeable option available
- BHMA Certified Grade 1 Security with standard mortise cylinder

Certifications:

- BHMA Certified ANSI A156.13 Grade 1 Series 1000
- ADA Compliant ANSI A117.1 Accessibility Code
- UL/cUL Listed for all functions up to 3 hours for "A" label doors
- UL10C Positive Pressure Rated
- UL10B Neutral Pressure Rated

Options:

Lead lining



**SPECIFICATIONS**

Lock Case:

4-5/16" x 6" x 1" (110 mm x 152 mm x 25 mm)

Armor Front:

- 1-1/4" x 8" x 7/32" (32 mm x 203 mm x 5 mm) - Standard
- 1-1/16" x 8" x 7/32" (27 mm x 203 mm x 5 mm) - Optional

Keys:

Two operating keys supplied per lock

Cylinders/Cores:

- Brass - keyed different - Schlage C Keyway
- Cylinder drilled 6-pin, keyed 5-pin - standard
- Other keying options, including keyed 6-pin, available from factory
- Large Format Interchangeable Core cylinder option available
- LFIC core available zero bitted or combined, brass 6- pin cores sold separately
- Small Format Interchangeable Core cylinder option available
- SFIC uncombined or combined, brass 6- or 7-pin cores sold separately
- Schlage "L" Cam - standard

Door Thickness:

- 1-3/4" - 2-1/2" (45 mm - 64 mm)
- Must specify door thickness if greater than 1-3/4" (45 mm)

Backset:

2-3/4" (70 mm) only

Deadbolt:

1" (25 mm) throw - stainless steel

Strike:

3991 1-1/4" x 4-7/8" (32 mm x 124 mm) no lip - Standard

Functions:

60 Cylinder x Thumbturn, 62 Double Cylinder, 63 Classroom, 64 Cylinder

Notes:

Self-adjusting case for beveled doors or square edge doors

**FINISHES**

- US3, US4, US10, US10B, US26, US26D
- US3, US4, US10, US10B, and US26 may be subject to extended lead time

**3800 SERIES DEADLOCK STRIKES**



**3991**

**No Lip Strike**

- Square corner
- 1-1/4" x 4-7/8" (32 mm x 124 mm)
- For use with 60, 62, 63 and 64 Functions only

**3800 SERIES MORTISE CYLINDERS**



**3902**

**Mortise Cylinder**

- If cylinder is ordered separately from the mortise lock, please specify Schlage "L" Cam
- Available in Conventional, Small Format Interchangeable Core, and Large Format Interchangeable Core (6-pin only)
- SFIC core sold separately
- LFIC core sold separately
- Conventional cylinder available in 1-1/8" (29 mm) and 1-1/4" (32 mm) length.
- SFIC cylinder available in 1-1/4" (32 mm) and 1-3/8" (35 mm) length
- LFIC cylinder available in 1-1/2" (38 mm) length
- For more cylinder information, please refer to Cylinder, Core, and Keying section.





## 3800 SERIES - GRADE 1 SMALL CASE MORTISE DEADLOCK - HEAVY DUTY

**WARRANTY** | Lifetime warranty

**FEATURES**

- Heavy duty commercial, industrial, institutional
- Non-handed (except for 33 Classroom Function)
- Conventional mortise cylinder, Small Format Interchangeable Core or Large Format Interchangeable Core option available
- BHMA Certified Grade 1 Security with standard mortise cylinder

Certifications:

- BHMA Certified ANSI A156.13 Grade 1 Series 1000
- ADA Compliant ANSI A117.1 Accessibility Code
- UL/cUL Listed for all functions up to 3 hours for "A" label doors
- UL10C Positive Pressure Rated
- UL10B Neutral Pressure Rated

Options: | Lead lining



### SPECIFICATIONS

Lock Case: | 4-5/16" x 3-9/16" x 1" (110 mm x 90 mm x 25 mm)

Armor Front: | • 1-1/4" x 5-5/8" x 7/32" (32 mm x 143 mm x 5 mm) - Standard

Keys: | Two operating keys supplied per lock

Cylinders/Cores:

- Brass - keyed different - Schlage C Keyway
- Cylinder drilled 6-pin, keyed 5-pin - standard
- Other keying options, including keyed 6-pin, available from factory
- Large Format Interchangeable Core cylinder option available
- LFIC core available zero bitted or combined, brass 6- pin cores sold separately
- Small Format Interchangeable Core cylinder option available
- SFIC uncombined or combined, brass 6- or 7-pin cores sold separately
- Schlage "L" Cam - standard

Door Thickness: | • 1-3/4" - 2-1/2" (45 mm - 64 mm)  
• Must specify door thickness if greater than 1-3/4" (45 mm)

Backset: | 2-3/4" (70 mm) only

Deadbolt: | 1" (25 mm) throw - stainless steel

Strike: | 3999 1-1/8" x 3-1/2" (29 mm x 89 mm) no lip - Standard

Functions: | 30 Cylinder x Thumbturn, 31 Door Bolt, 32 Double Cylinder, 33 Classroom, 34 Cylinder

Notes: | Self-adjusting case for beveled doors or square edge doors

### FINISHES

- US3, US4, US10, US10B, US26, US26D
- US3, US4, US10, US10B, and US26 may be subject to extended lead time

### 3800 SERIES DEADLOCK STRIKES



#### 3999

##### No Lip Strike

- Square corner
- 1-1/8" x 3-1/2" (29 mm x 89 mm)
- For use with 30, 31, 32, 33 and 34 Functions only

### 3800 SERIES MORTISE CYLINDERS



#### 3902

##### Mortise Cylinder

- If cylinder is ordered separately from the mortise lock, please specify Schlage "L" Cam
- Available in Conventional, Small Format Interchangeable Core, and Large Format Interchangeable Core (6-pin only)
- SFIC core sold separately
- LFIC core sold separately
- Conventional cylinder available in 1-1/8" (29 mm) and 1-1/4" (32 mm) length.
- SFIC cylinder available in 1-1/4" (32 mm) and 1-3/8" (35 mm) length
- LFIC cylinder available in 1-1/2" (38 mm) length
- For more cylinder information, please refer to Cylinder, Core, and Keying section.



## 3800 SERIES - SLIDING DOOR MORTISE LOCK - HEAVY DUTY

<b>WARRANTY</b>	Lifetime warranty
<b>FEATURES</b>	<ul style="list-style-type: none"> <li>• Heavy duty commercial, industrial, institutional</li> <li>• Non-handed</li> <li>• Conventional mortise cylinder, Small Format Interchangeable Core or Large Format Interchangeable Core option available</li> </ul>
Certifications:	<ul style="list-style-type: none"> <li>• ADA Compliant ANSI A117.1 Accessibility Code</li> </ul>
<b>SPECIFICATIONS</b>	
Lock Case:	4-5/16" x 3-9/16" x 1" (110 mm x 90 mm x 25 mm)
Armor Front:	1-1/4" x 5-5/8" x 7/32" (32 mm x 143 mm x 5 mm) - Standard
Keys:	Two operating keys supplied per lock
Cylinders/Cores:	<ul style="list-style-type: none"> <li>• Brass - keyed different - Schlage C Keyway</li> <li>• Cylinder drilled 6-pin, keyed 5-pin - standard</li> <li>• Other keying options, including keyed 6-pin, available from factory</li> <li>• Large Format Interchangeable Core cylinder option available</li> <li>• LFIC core available zero bitted or combined, brass 6- pin cores sold separately</li> <li>• Small Format Interchangeable Core cylinder option available</li> <li>• SFIC uncombined or combined, brass 6- or 7-pin cores sold separately</li> <li>• Schlage "L" Cam - standard</li> </ul>
Door Thickness:	<ul style="list-style-type: none"> <li>• 1-3/4" - 2-1/2" (45 mm - 64 mm)</li> <li>• Must specify door thickness if greater than 1-3/4" (45 mm)</li> </ul>
Backset:	2-3/4" (70 mm) only
Deadbolt:	1" (25 mm) throw - stainless steel
Strike:	1-1/8" x 3-1/2" (29 mm x 89 mm) no lip - Standard
Functions:	35 Cylinder x Thumbturn, 36 Single Cylinder, 37 Double Cylinder, 38 Thumbturn Only, 39 Thumbturn with Emergency Key (Privacy)
<b>FINISHES</b>	U26D



### 3800 SERIES MORTISE CYLINDERS



#### 3902 Mortise Cylinder

- If cylinder is ordered separately from the mortise lock, please specify Schlage "L" Cam
- Available in Conventional, Small Format Interchangeable Core, and Large Format Interchangeable Core (6-pin only)
- SFIC core sold separately
- LFIC core sold separately
- Conventional cylinder available in 1-1/8" (29 mm) and 1-1/4" (32 mm) length.
- SFIC cylinder available in 1-1/4" (32 mm) and 1-3/8" (35 mm) length
- LFIC cylinder available in 1-1/2" (38 mm) length
- For more cylinder information, please refer to Cylinder, Core, and Keying section.



# Cylinder, Core & Keying

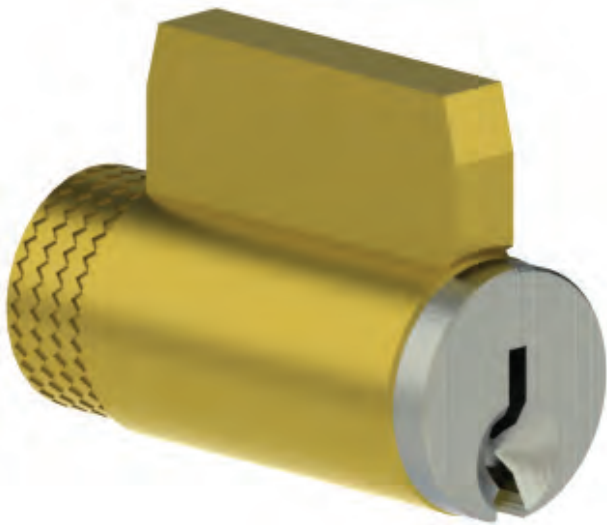



## CYLINDER, CORE & KEYING - CONVENTIONAL CYLINDERS

### Keying Options

Keyed function locks are supplied standard with Schlage 'C' keyway cylinder, cylinder drilled 6-pin, keyed 5-pin and will be keyed different with two operating keys unless otherwise specified.

- Keyed Alike, 0 Bitted, 1 Bitted
- Master Keyed [must specify quantity of Master keys where applicable, 3961 (5-pin) or 3962 (6-pin)]
- Construction Master Keyed (Schlage C, E & F)
- Keyed to Specific or Existing Number
- Submit master keying form; pages 88-91 or at [www.hagerco.com](http://www.hagerco.com)
- Extra Cut Keys (3961 - Cut 5-pin, 3962 - Cut 6-pin)
- Key Markings: 1AA, 2AA etc. (per key)
- Key Markings other than Key Set (per key)
- Cylinder markings
- Bitting Lists are available, ordered separately from Master Keyed order, specify 3998
- All optional keyways below may not be immediately available. Contact customer service for more information on a particular keyway.

### Optional Keyways (Conventional Cylinders)



**Arrow AR1**



**Corbin 60**



**Corbin 77**



**Corbin/  
Ruswin L4**



**Kwikset KW1**



**Weiser E**



**Ruswin D1**



**Sargent LA**



**Schlage E**



**Schlage F**



**Yale E1R  
(PARA)**



**Yale GA**

### Keys



**3955**  
**Key Blank**  
5-pin, C keyway



**3961**  
**Cut Key**  
5-pin, keyed to specific or existing number



**3956**  
**Key Blank**  
6-pin, C keyway



**3962**  
**Cut Key**  
6-pin, keyed to specific or existing number





## CYLINDER, CORE & KEYING - CONVENTIONAL CYLINDERS

### Cylinders



**3960**  
**Key-in Lever/Deadlock Cylinder**  
 Includes two operating keys  
 Specify keyway, tailpiece, and how keyed  
 Note: Cylinder instructions and ordering guide available on [www.hagerco.com](http://www.hagerco.com)

### Tailpieces



**2-639-7000**  
**Tailpiece 1**  
 Pack of 10 tailpieces for use with 3453L, 3450L, 3480L, 2580L



**2-639-7001**  
**Tailpiece 2**  
 Pack of 10 tailpieces for use with 3470L



**2-639-7002**  
**Tailpiece 3**  
 Pack of 10 tailpieces for use with 3453K, 3480K, 3550L, 3553L, 3553K, 3579L, 3580L, 3580K, 3753L, 2550L, 2553L



**2-639-7003**  
**Tailpiece 4**  
 Pack of 10 tailpieces for use with 3470K, 3570K



**2-639-7005**  
**Tailpiece 6**  
 Pack of 10 tailpieces for use with 3114DB and 3214DB exterior cylinders



**2-639-7006**  
**Tailpiece 7**  
 Pack of 10 tailpieces for use with 3114DB and 3214DB interior cylinders



**2-639-7007**  
**Tailpiece 8**  
 Pack of 10 tailpieces for use with 3115DB, 3118DB, 3215DB, 3710DB, 3753DB



**2-639-7008**  
**Tailpiece 9**  
 Pack of 10 tailpieces for use with 3653L, 3670L and 3680L



**2-639-7018**  
**Tailpiece W**  
 Pack of 10 tailpieces for use with 3473L



**2-639-7087**  
**Tailpiece Z**  
 Pack of 10 tailpieces for use with 3570L and 3573L



**2-639-7094**  
**Tailpiece X**  
 Pack of 10 tailpieces for use with 3495L



**2-639-7192**  
**Tailpiece K**  
 Pack of 10 tailpieces for use with 4700 key-in-lever trim (KE, KN)



**2-639-7322**  
**Tailpiece V**  
 Pack of 10 tailpieces for use with 2570L

### Rim Cylinder Housing



**3901**  
**Rim Cylinder**

- Conventional cylinder supplied drilled 6-pin, keyed 5-pin standard
- Furnished with trim ring, mounting plate, and break off screws
- Long tail piece standard
- Supplied with two operating keys

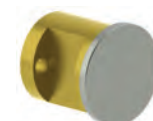

**3903**  
**Rim Dummy Cylinder**





**CYLINDER, CORE & KEYING - CONVENTIONAL CYLINDERS**

**Rim Cylinder Accessories**



**2-639-7058**  
**Long Breakoff Tailpiece**  
2-3/8" (60 mm)



**2-300-0118**  
**Extra Long Breakoff Screws**  
2-3/8" (60 mm)



**2-649-0137**  
**Retaining Cup**  
Can be used with 45PN, 47PN, and 47RN

**Mortise Cylinder Housing**



**3902**  
**Mortise Cylinder**

- Conventional cylinder supplied drilled 6-pin, keyed 5-pin standard
- 3975 standard cam attached and 3972 Adams Rite cam shipped loose in the box
- Thread size is 1.150" x 32 UNS
- Cylinder face diameter is 1.360"
- Supplied with two operating keys
- 1-1/8" (29 mm) standard length, 1-1/4" (31 mm), and 1-5/8" (41 mm) for mortise exit devices
- Other lengths may be available with extended lead time
- **Must specify length, cam, keyway, and keying requirements**



**3904**  
**Mortise Dummy**

- 1-1/8" (29 mm) length
- 1-1/4" (31 mm) length



**3905**  
**Mortise ADA Turn Knob**

- 1-1/8" (29 mm) length
- 1-1/4" (31 mm) length

Note: Ships with Schlage "L" Cam; specify if different

**Mortise Cylinder Cams**



**3971**  
**Yale Cam**  
Radius .722" (18 mm)



**3972**  
**Adams Rite Cam**  
Radius .560 (14 mm)



**3973**  
**Standard Cloverleaf**  
Radius .741" (19 mm)



**3974**  
**Marks Cam**  
Radius .755" (19 mm)



**3975**  
**Standard Cam**  
Radius .723" (18 mm)  
For use with Hager exit devices and trim



**3976**  
**Schlage L Cam**  
Radius .637" (16 mm)  
For use with Hager mortise locks (all functions)



**3977**  
**Sargent/Yale Cam**  
Radius .733" (18.6 mm)



**3978**  
**Corbin/Ruswin/Best Cloverleaf**  
Radius .725" (18.5 mm)





## CYLINDER, CORE & KEYING - SMALL FORMAT INTERCHANGEABLE CORE

### Keying Options

Cores are furnished keyed different unless otherwise specified. Other keying options include:

- Keyed Alike
- Construction Cores
- Master keyed (Must specify quantity of master keys, control keys, or additional change keys, 3984.)
- Keyed to specific or existing number
- Key Markings: 1AA, 2AA etc. (per key) - VKC
- Key markings other than key set
- Core markings (Visual or concealed)
- Do not duplicate
- Bitting Lists are available, ordered separately from Master Keyed order, specify 3998

\* Construction master keyed not available.

### SFIC Keyways (Best) - A, B, C, D, E, F, G, H, J, K, L, M, Q

#### SFIC Cores



**3981-C**  
**Combined Core 6-Pin**  
Includes two change keys  
Finishes include US4 or US26D

**3981-U**  
**Uncombined Core 6-Pin**  
Includes two key blanks  
Finishes include US4 or US26D



**3982-C**  
**Combined Core 7-Pin**  
Includes two change keys  
Finishes include US4 or US26D

**3982-U**  
**Uncombined Core 7-Pin**  
Includes two key blanks  
Finishes include US4 or US26D

#### SFIC Keys



**3983**  
**SFIC Key Blank**  
Best Keyways used with 6-pin and 7-pin cores



**3984**  
**SFIC Cut Key**  
Best Keyways used with 6-pin and 7-pin cores

### SFIC Construction Cores

Construction Small Format Interchangeable Cores are available in blue or red and are keyed alike. Will receive full credit, less shipping, of original cost upon return of construction cores with keys.



**3981-Blue or 3981-Red**  
**Construction Core**  
Combined, 6-pin  
Includes two operating keys

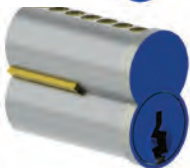

**3982-Blue or 3982-Red**  
**Construction Core**  
Combined, 7-pin  
Includes two operating keys

### SFIC Construction Core Keys



**2-639-7168**  
**3984 Control Key (BA IC 6 Blue)**

**2-639-7169**  
**3984 Control Key (BA IC 7 Blue)**

**2-639-7170**  
**3984 Control Key (BA IC 7 Red)**

**2-639-7113**  
**3984 Control Key (BA IC 6 Red)**

Note: Two (2) control keys will be shipped with an order unless otherwise specified.



**CYLINDER, CORE & KEYING - SMALL FORMAT INTERCHANGEABLE CORE**

**SFIC Tailpieces**



**2-639-7060**  
Pack of 10 tailpieces for use with 2500/3500 Series SFIC lever (6-pin/7-pin combo)



**2-639-7061**  
Pack of 10 tailpieces for use with 3400/3500 Series SFIC knob (6-pin/7-pin combo)



**2-639-7090**  
Pack of 10 tailpieces for use with 3753 Interconnected Lock SFIC lever (6-pin/7-pin combo)



**2-639-7091**  
Pack of 10 tailpieces for use with 3114/3214 SFIC deadbolt (6-pin/7-pin combo)



**2-639-7095**  
Pack of 10 tailpieces for use with 3115/3118/3215 and 3710/3753 SFIC deadbolt (6-pin/7-pin combo)

**SFIC Rim Cylinder Housing**

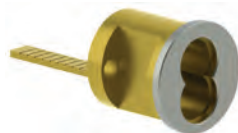

**3901 Rim Cylinder**  

- Furnished with trim ring, mounting plate, and break off screws
- Long tail piece standard
- Small Format Interchangeable Core housing supplied less core
- Specify 6- or 7-pin

**SFIC Rim Cylinder Accessories**



**2-639-7058 Long Breakoff Tailpiece**  
2-3/8" (60 mm)



**2-300-0118 Extra Long Breakoff Screws**  
2-3/8" (60 mm)



**2-649-0137 Retaining Cup**  
Can be used with 45PN, 47PN, and 47RN

**SFIC Mortise Cylinder Housing**



**3902 Mortise Cylinder**  

- 2-639-7082 standard cam; 2-639-7083 Adams Rite cam shipped loose in the box
- Thread size is 1.150" x 32 UNS. Cylinder face diameter is 1.360"
- Small Format Interchangeable Core housing supplied less core
- **Must specify length and cam, 6-pin 1-1/4", 7-pin 1-3/8", 7-pin 1-5/8" (for mortise exit device)**

**SFIC Mortise Cylinder Cams**



**2-639-7082 Standard Yale Cam**



**2-639-7083 Adams Rite Cam**



**2-639-7084 Standard Cloverleaf Cam**



**2-639-7085 Schlage "L" Cam**  
For use with Hager mortise locks (all functions)



**2-639-7086 Sargent/Yale Cam**





## CYLINDER, CORE & KEYING - LARGE FORMAT INTERCHANGEABLE CORE

### Keying Options

Cores are furnished zero bitted - unless otherwise specified. Other keying options include:

- Keyed alike
- Keyed different
- Master keyed (must specify quantity of master keys, control keys or additional change keys)
- Construction master keyed
- Keyed to specific or existing number
- Key Markings: 1AA, 2AA etc. (per key) - VKC
- Key markings other than key set
- Core markings (visual or concealed)
- Bitting Lists are available, ordered separately from master keyed order, specify 3998

### LFIC Cores (Available in Schlage C Only)



**3919**  
**Zero Bitted Core 6-Pin**  
 Includes two key blanks  
 Finishes include US4 or US26D

**Combinated Core 6-Pin**  
 Includes two change keys  
 Finishes include US4 or US26D

### LFIC Tailpieces



**2-639-7645**  
 50, 53 and 80 functions only



**2-639-7646**  
 70 function only



**2-639-7647**  
 73 and 95 functions only

### LFIC Rim Cylinder Housing



**3901**  
**Rim Cylinder**

- Furnished with trim ring, mounting plate, and break off screws
- Tail piece supplied standard
- Large Format Interchangeable Core housing supplied less core.
- 6-pin only

### LFIC Keys



**3956**  
**Key Blank**  
 Schlage C Keyway, 6-pin only



**3962**  
**Cut Key**  
 Schlage C Keyway, 6-pin only



**3963**  
**3919 Control Cut Key**



**2-639-7649**  
**3919 Control Key Blank**

### LFIC Rim Cylinder Accessories



**2-639-7578**  
**Breakoff Tailpiece Assy**  
 2-3/8" (60 mm)



**2-300-0175**  
**Breakoff Screws**  
 2-1/8" (54 mm)



## CYLINDER, CORE & KEYING - LARGE FORMAT INTERCHANGEABLE CORE

### LFIC Mortise Cylinder Housing



#### **3902**

##### **Mortise Cylinder**

- 2-639-7082 standard cam;  
2-639-7083 Adams Rite Cam shipped loose in the box.
- Thread size is 1.150" x 32 UNS.  
Cylinder face diameter is 1.360".
- Large Format Interchangeable Core housing supplied less core
- **Must specify cam, 1-1/2" length**

### LFIC Mortise Cylinder Cams



#### **2-639-7570** **Standard Yale Cam**



#### **2-639-7571** **Adams Rite Cam**



#### **2-639-7572** **Schlage "L" Cam** For use with Hager mortise locks (all functions)



#### **2-639-7573** **Corbin Cam**



#### **2-639-7574** **Sargent/Yale Cam**





## CYLINDER, CORE & KEYING - CONVENTIONAL CYLINDERS - HAGER KEYWAY - (7-PIN ONLY)

### Keying Options

Keyed function locks are supplied keyed different unless otherwise specified.

- Keyed alike, 0 bitted, 1 bitted
- Master keyed (must specify quantity of Master keys where applicable)
- Construction master keyed
- Keyed to specific or existing number
- Submit master keying form (page 86)
- Extra cut keys (3908 - Cut 7-pin)
- Key markings: 1AA, 2AA etc. (per key)
- Key markings other than key set (per key)
- Cylinder markings (visual or concealed)
- Do not duplicate standard
- Bitting lists are available, ordered separately from Master keyed order, specify 3998

Notes: • Keys are cut bow to tip

- Must purchase capping block/press and key punch due to 140 pin spacing

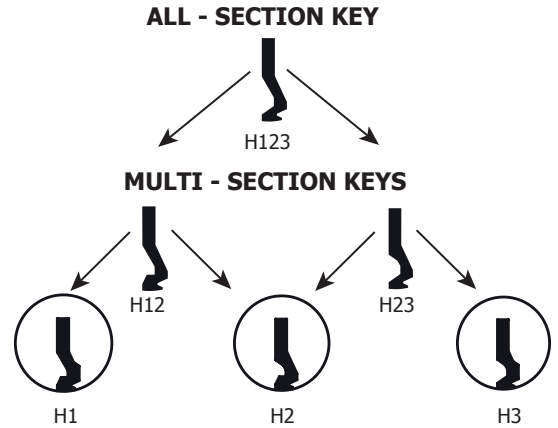

### Hager Keyway (Conventional Cylinders)



**Hager H1**



**Hager H2**



**Hager H3**

### Cylinders



#### 3906

##### Key-in Lever/ Deadlock Cylinder

- 140 Pin spacing
- Includes two operating keys
- Specify Hager keyway, tailpiece, and keying requirements

Note: Cylinder instructions and ordering guide available online.

### Rim Cylinders



#### 3901

##### Rim Cylinder

- 140 Pin spacing
- Conventional cylinder supplied 7-pin only
- Furnished with trim ring, mounting plate, and break off screws
- Long tail piece standard
- Supplied with two operating keys

### Mortise Cylinders



#### 3902

##### Mortise Cylinder

- 140 Pin spacing
- Conventional cylinder supplied 7-pin only
- 3975 standard cam attached and 3972 Adams Rite cam shipped loose in the box
- Thread size is 1.150" x 32 UNS
- Cylinder face diameter is 1.360"
- Supplied with two operating keys
- 1-1/8" (29 mm) standard length, 1-1/4" (31 mm) available, 1-5/8" (41 mm) for mortise exit devices
- **Must specify length, cam, keyway, and keying requirements**

### Keys



#### 3907

##### Key Blank

Hager keyways (H1, H2, H3, H12, H23, H123)



#### 3908

##### Cut Key

- Hager keyways (H1, H2, H3, H12, H23, H123)
- Specify keying required (masterkey, construction masterkey, control key)



**CYLINDER, CORE & KEYING - SFIC - HAGER KEYWAY - (7-PIN ONLY)**

**Keying Options**

Cores are furnished keyed different unless otherwise specified. Other keying options include:

- Keyed alike
- Master keyed (must specify quantity of master keys, control keys or additional change keys)
- Keyed to specific or existing number
- Key markings: 1AA, 2AA etc. (per key) - VKC
- Key markings other than key set
- Core markings (visual or concealed)
- Do not duplicate standard
- Bitting lists are available, ordered separately from master keyed order, specify 3998
- \* Construction master keyed not available.

Notes: • Keys are cut bow to tip  
• Must purchase capping block/press and key punch due to 140 pin spacing

**Keyways (Hager) - H1, H2 and H3 SFIC Cores**



- 3969**  
**Combined Core 7-Pin**
- Includes two change keys
  - Finishes include US4 or US26D
  - 140 Pin spacing



- 3909**  
**Uncombined Core 7-Pin**
- Includes two key blanks
  - Finishes include US4 or US26D
  - 140 Pin spacing

**SFIC Rim Cylinder Housing**

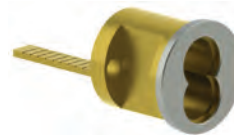

- 3901**  
**Rim Cylinder**
- Furnished with trim ring, mounting plate, and break off screws
  - Long tail piece standard
  - Small Format Interchangeable Core housing supplied less core
  - Specify 7-pin

**SFIC Mortise Cylinder Housing**



- 3902**  
**Mortise Cylinder**
- 2-639-7082 standard cam; 2-639-7083 shipped loose in the box
  - Thread size is 1.150" x 32 UNS. Cylinder face diameter is 1.360".
  - Small Format Interchangeable Core housing supplied less core
  - **Must specify length and cam, 7-pin 1-3/8"**

**SFIC Keys**



- 3907**  
**SFIC Key Blank**  
Hager keyways (H1, H2, H3, H12, H23, H123)



- 3908**  
**SFIC Cut Key**
- Hager keyways (H1, H2, H3, H12, H23, H123)
  - Specify keying required (masterkey, construction masterkey, control key)





## CYLINDER, CORE & KEYING - HAGER KEYWAY ACCESSORIES

### **2-639-7511**

#### **Pin Kit**

- Includes top pins, SFIC bottom pins, full size bottom pins and springs
- Does not include SFIC caps

### **2-639-7517**

#### **Construction Balls**

- Used for lost ball construction key
- Order in multiples of 1,000

### **2-639-7519**

#### **Retaining Pin Spring**

Sold in multiples of 100

### **2-639-7520**

#### **Individual SFIC Caps**

Sold in multiples of 500

### **2-639-7526**

#### **Retaining Pin**

Secures screw cap on KIK cylinder

### **2-639-7527**

#### **Plug Follower (KIK)**

### **2-639-7529**

#### **Decombinating Punch**

### **2-639-7530**

#### **Capping Punch**

### **2-639-7531**

#### **Decombinating Block (Punch Included)**

### **2-639-7532**

#### **Manual Capping Block (Punch Included)**

140 spacing

### **2-639-7534**

#### **Cap Saver Press**

- Recommended for field pinning uncombined SFIC cores
- 140 spacing

### **2-639-7535**

#### **Key Punch**

140 spacing

### **2-639-7536**

#### **HPC 1200 Series Code Card**

140 spacing





## CYLINDER, CORE & KEYING - PINS

Original Manufacturer Nickel Silver Pins (Sold in multiples of 100)		
Part Number	Description	Size
2-639-8188	Top Pin	#2
2-639-8189	Top Pin	#3
2-639-8190	Top Pin	#4
2-639-8191	Top Pin	#5
2-639-8192	Top Pin	#6
2-639-8193	Top Pin	#7
2-639-8194	Top Pin	#8
2-639-8195	Top Pin	#9
2-639-8196	Top Pin	#10
2-639-8197	Top Pin	#11
2-639-8198	Top Pin	#12
2-639-8199	Top Pin	#13
2-639-8200	Top Pin	#14
2-639-8201	Top Pin	#15
2-639-8202	Top Pin	#16
2-639-8203	Top Pin	#17
2-639-8204	Top Pin	#18
2-639-8205	Top Pin	#19
2-639-8210	Full Bottom	#0
2-639-8211	Full Bottom	#1
2-639-8212	Full Bottom	#2
2-639-8213	Full Bottom	#3
2-639-8214	Full Bottom	#4
2-639-8215	Full Bottom	#5
2-639-8216	Full Bottom	#6
2-639-8217	Full Bottom	#7
2-639-8218	Full Bottom	#8
2-639-8219	Full Bottom	#9
2-639-8220	SFIC Bottom	#0
2-639-8221	SFIC Bottom	#1
2-639-8222	SFIC Bottom	#2
2-639-8223	SFIC Bottom	#3
2-639-8224	SFIC Bottom	#4
2-639-8225	SFIC Bottom	#5
2-639-8226	SFIC Bottom	#6
2-639-8227	SFIC Bottom	#7
2-639-8228	SFIC Bottom	#8
2-639-8229	SFIC Bottom	#9





## CYLINDER, CORE & KEYING - HOW TO ORDER KEY SYSTEMS

### 2 LEVEL SYSTEMS

#### Simple Master Key System

The master key symbol consists to TWO letters, **AA**. The change key numbers are added to the master key letters. The numbers come FIRST for a simple master key system, example: **1AA, 2AA, 3AA, etc.**

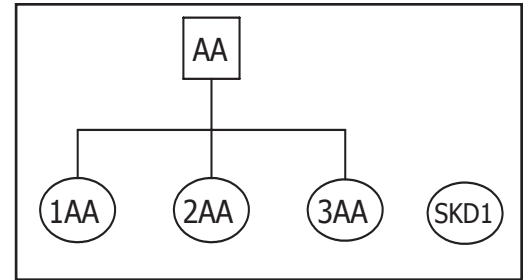

### 3 LEVEL SYSTEMS

#### Grand Master Key System

The grand master keyset symbol is assigned ONE letter, starting with **A**. The master keyset symbols under this grand are assigned TWO letters, the first of which will be the same as the grand; **AA, AB, AC, etc.** are all masters under the grand **A**. (Caution: **Do not use the letters, I, O, Q or X** because of the possible confusion with the numbers 1 & O. X is reserved for identifying cross keying.) Change key numbers come **AFTER** the letters, example: **AA1, AA2, AA3, etc.**

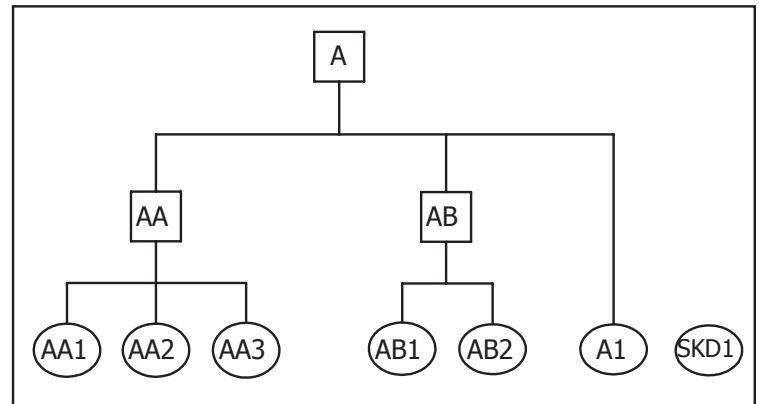

For master keyset symbols beyond AZ, insert a number between the letters to designate which pass through the alphabet they represent. **A2A** through **A2Z** represent the second pass through the alphabet of masters under the Grand **A**. **A3A** through **A3Z** would be the third pass through the alphabet. Change keys under these masters have the numbers suffixed in the usual way **A2A1, A2A2, A2A3, etc.**

If a cylinder is to be operated by its change key and the GMK only (No master), the change number is added to the GMK symbol. This is illustrated by the keyset symbol **A1** in the schematic shown.

### 4 LEVEL SYSTEMS

#### Great Grand Master Key System

The great grand master is assigned the keyset symbol **GGM**. The rest of the symbols are the same as those in a 3 level system.

The grand master keys under the GGM are assigned the keyset symbol of single letters of the alphabet **A, B, C, D, etc.**, starting with **A**. The master keyset symbols under this grand are assigned TWO letters, the first of which will be the same as the grand; **AA, AB, ..., BA, BB, ..., CA, CB, ..., etc.** (Caution: **Do not use the letters, I, O, Q or X** because of the possible confusion with the numbers 1 & O. X is reserved for identifying cross keying.) Change key numbers come **AFTER** the letters, example: **AA1, AA2, AA3, etc.**

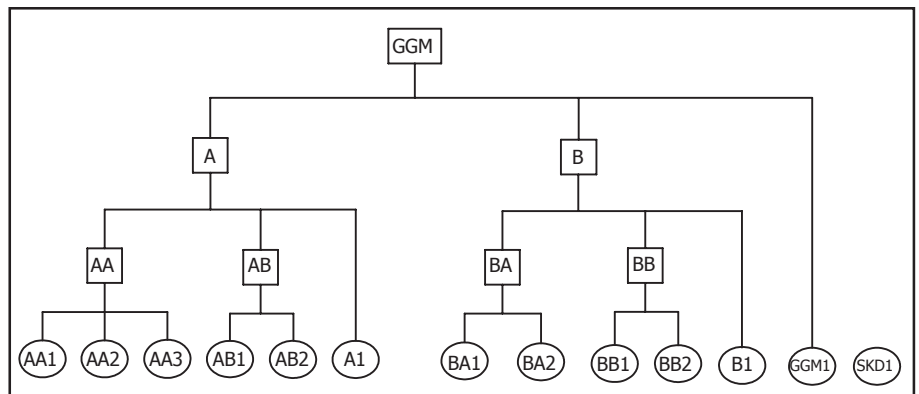

For masters beyond AZ, insert a number between the letters to designate which pass through the alphabet they represent. **A2A** through **A2Z** represent the second pass through the alphabet of masters under the Grand **A**. **A3A** through **A3Z** would be the third pass through the alphabet. Change keys under these masters have the numbers suffixed in the usual way **A2A1, A2A2, A2A3, etc.**

If a cylinder is to be operated by its change key and the GGM only (No grandmaster, no master), the change number is added to the GGM keyset symbol. This is illustrated by the keyset symbol **GGM1** in the schematic shown.



## CYLINDER, CORE & KEYING - HOW TO ORDER KEY SYSTEMS

### **SINGLE KEYED DIFFERENT (SKD)** (Example: Narcotics Room, Pharmacies)

When requirements are such that no other key operates the cylinder (master, other change keys, etc.) they are referred to as "single keyed different" and given the keyset symbol **SKD**. When more than one SKD is required in a facility, they are numbered **SKD1, SKD2, SKD3, etc.**

### **NO MASTER KEY (NMK)**

When keying requirements are such that all higher levels of master keys do not operate the cylinder, the suffix **(NMK)** is added to the keyset symbol. For example, **AA1 (NMK)** is operated by the change key **AA1** only. Neither the A grand, nor the **AA** master operate the cylinder. A keyset symbol, **AA (NMK)** indicates the cylinder to be operated by the **AA** master only, the **A** grand does not operate the cylinder.

### **SELECTIVE MASTER KEYS**

It is often useful in large keying systems to issue a high level master key to maintenance personnel which allows access across all master and grand master key boundaries of a keying system.

To designate that a lock be operated by a selective master key, suffix the symbol in parentheses to the standard symbol. Example: **AA1 (ENG)**. This must be added every time the selective key is to operate and left off whenever the selective key is NOT to operate. For instance, you may lay out a system in which key **AA1** is to operate two different offices. Inside one of them is an electrical cabinet which must be accessible to maintenance personnel carrying the **ENG** key. That lock must be specified as **AA1 (ENG)**, while the lock for the other office must be specified as **AA1**.

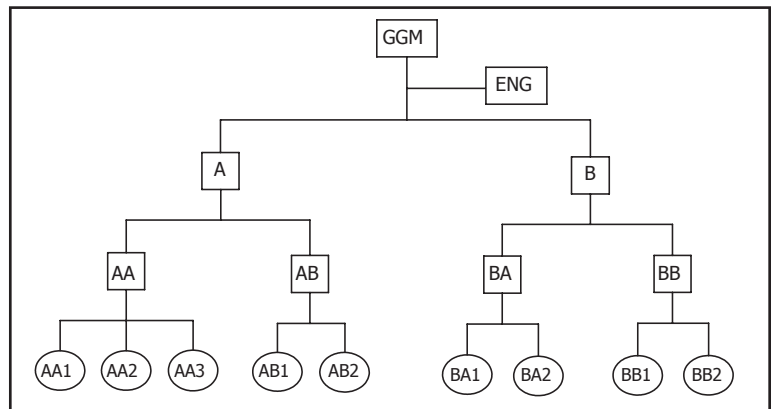

Selective master key is a convenience feature which decreases the security of the cylinders it operates and limits the expansion and flexibility of the overall keying system. Each selective master key typically eliminates 20-25% of the capacity of the system where it is used, so it should only be specified when absolutely required. It is recommended that no more than one system-wide selective master key be used within the same system.

### **CROSS KEYING**

Like selective master keying, cross keying is a convenience feature and will limit the expansion and flexibility of the overall key system. Whenever two or more different change keys such as **AA1 and AA2** are both required to operate the same cylinder, the cylinder's security is reduced. This is called cross keying. When the cross keying occurs under all the same higher levels (MK, GMK, GGMK), such as **AA1 and AA2**, it is known as controlled cross keying. When you combine keys under different higher levels (MK, GMK, GGMK), such as **AA1 and AB1**, it is known as uncontrolled cross keying, which you NEVER want to do.

Convenience may reduce cylinder security and hinder the overall key system expansion. Cross keying usually imposes limits on the flexibility and expansion of the overall keying system. This is especially true of uncontrolled cross keying. For these reasons, it is strongly recommended to allow personnel to carry more than one key. Cross keying should be discouraged whenever possible. However, when cross keying is required, it is specified as follows, and should be summarized at the beginning of each order. It cannot normally be added later. Each cross keyed set should also be limited to keys which are all under the same higher level master keys. Prefix the keyset symbol with the letter **X** (example: **XAA3**) All keys which are to operate the cylinder are to be listed following the keyset symbol with the phrase "to be operated by" ("TBOB", "OB", "operated by" are also common phrases/abbreviations used. Example: **XAA3**, operated by **AA1, AA2, AA**, and **A**. Note that **X** is a cylinder designation only. The change keyset would be **AA3**.

**NOTE: HAGER WILL NOT DO UNCONTROLLED CROSS KEYING DUE TO THE REDUCED SECURITY IT CAUSES.**



## CYLINDER, CORE & KEYING - HOW TO ORDER KEY SYSTEMS

### CONSTRUCTION MASTER KEYING

Hager uses the lost ball method for construction keying for conventional cylinders. If you have ordered Small Format Interchangeable Core (SFIC), you will be able to order temporary cores (Blue & Red are stock). Permanent cores will be shipped with permanent keys.

#### Recommendation:

Use as many keyed alike groups to conserve bitting combinations. Study blueprints and/or master plans for campuses to identify areas where more than one door leads into the same space, and where several different areas are used by the same personnel. These areas should be keyed alike (use the same keyset symbol). This conserves key bitting combinations for future use as well as reduces the need to issue master keys. Remember, key systems are much like a rubber band, it only stretches so far. You can stretch it horizontally to create more master keys, or vertically to create more changes under each master, but there is a finite number of combinations available.

#### Case #1 (Cross Keying)

Cylinder requires its own change key. The illustration depicts part of a small medical building where two doctors share a common receptionist. The receptionist gets the **AA3** change key. Each doctor carries a key which operates only one office, but also operates the entrance from the corridor, by cross keying that cylinder to include the following keys to operate it. **XAA3, TBOB** (To Be Operated By) **AA1, AA2, AA and A**.

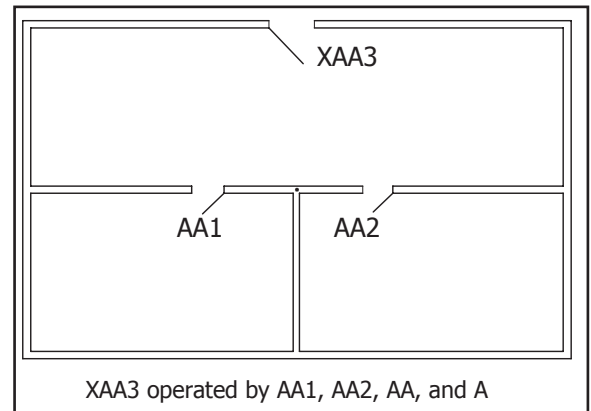

#### Case #2

The hall door cylinder does not require its own change key. This illustration depicts a section of a floor in a dormitory. Each student's bedroom change key operates the hall door cylinder. There is no need to construct a change key which operates only the hall door.

In this case, place an **X** at both the beginning and the end of the keyset symbol and a number between them. Example: **X1X, X2X, etc.** Again, always include the "TBOB" (to be operated by) phrase with a complete listing of the keyset symbols to operate the cylinder.

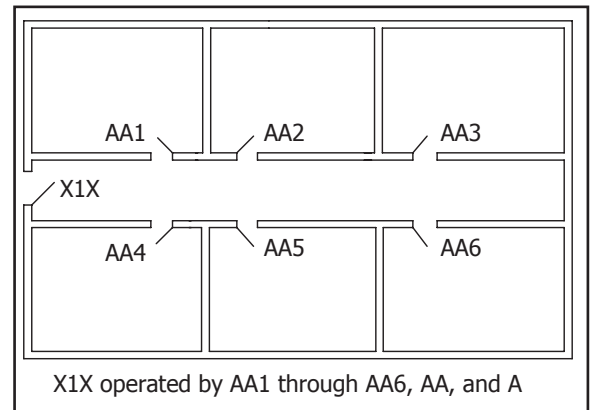



# Master Keying Form

Hager order number: \_\_\_\_\_  
 Account number: \_\_\_\_\_  
 Customer: \_\_\_\_\_  
 Customer PO number: \_\_\_\_\_  
 Job name: \_\_\_\_\_  
 Location: \_\_\_\_\_

Ship Lock to:  
 \_\_\_\_\_

Requested ship date: \_\_\_\_\_

### 1. System

- New                       Existing

If existing, please attach biting sheet and complete following field:

Original Hager order number: \_\_\_\_\_

### 2a. System type

- Conventional keyed 5-pin
- Conventional keyed 6-pin/ includes LFIC
- Conventional keyed 7-pin (H1, H2, H3 Only)
- SFIC keyed 6-pin    A2  A4
- SFIC keyed 7-pin    A2  A4
- LFIC keyed 6-pin    (Schlage C only)

\* Hager Keyway available in 7-pin only (Conventional & Interchangeable Core)

### 2b. Keyways

- Arrow AR1             Corbin 60             Corbin 67
- Corbin 77             Corbin/RW L4        Hager H1     H12
- Kwikset KW1        Weiser E             Hager H2     H23
- Sargent LA          Schlage C            Hager H3     H123
- Yale E1R             Schlage E            Russwin D1
- Yale GA              Schlage F
- Best (Specify Keyway) \_\_\_\_\_

### Change keys

- Per core/cylinder
- Per key symbol

### Quantity

### Special function

- Control
- Maintenance
- Housekeeping
- Mechanical
- Engineering
- Janitorial
- SKD
- Other

### Quantity

### 4a. Key stamping (visual key control)

- None
- Key set symbol
- Door number
- Bitting number
- Do not duplicate (standard with interchangeable core & Hager Keyways)
- Other \_\_\_\_\_

Please note that visual key control is recommended, otherwise, keys will be tagged with temporary identification.

### 3. System level AND key quantity

Level	Quantity
<input type="radio"/> GGGMK	
<input type="radio"/> GGMK	
<input type="radio"/> GMK	
<input type="radio"/> MK	
<input type="radio"/> Construction MK (Lost Ball) (Sch/Hag Conv. Only)	
<input type="radio"/> Other	

### 4b. Cylinder Control

- None                       KSS (Key Set Symbol)
- Concealed               DN (Door Number)
- Visual                     Other

**Please fill out this form completely and fax to 800-782-0149 or email to masterkey@hagerco.com with the document as an attachment.**

5. Packing

- Pack keys with lock/ cores
- Pack keys separate from lock/ cores

Ship To: (keys separate)

6. 3998 bitting list

- Yes  No

Ship to/ E-mail to:

Marking instructions (labels, packaging, etc.):

7. Future expansion (list future MK symbols, approximate number of change key symbols)

8. Contact Information for questions:

Name \_\_\_\_\_

Title: \_\_\_\_\_

Phone: \_\_\_\_\_

Fax: \_\_\_\_\_

Email: \_\_\_\_\_

Signature: \_\_\_\_\_

Is a signature required for future keying?  Yes  No

If yes:

Please note that this document will become part of the permanent keying files for this project. If the requirements for this master keying form change, it is the responsibility of the end user/owner to notify their local factory representative or Hager Companies.

9. Additional information/ Special Instructions



May submit excel file in lieu of this sheet.

Total quantity

Product

Stock number

Finish

--	--	--	--

Quantity	Door #	Keyset	Hardware set	Operated by	Remarks

More sheets added online.







**One Family. One Brand. One Vision.™**

[www.hagerco.com](http://www.hagerco.com)

# Door Controls



Hager Companies offers a comprehensive line of door control products designed and manufactured to meet a wide range of applications and uses. From humble beginnings in 1849 as a forger of wheel rims and hardware for Conestoga wagons, today Hager offers surface mounted and commercial grade closers, electromagnetic holders and overhead door holders and stops in our door controls product line. Hager door closers provide architects, contractors, and building owners a superior product with proven reliability. That makes them a no-risk choice for virtually any building type. Because these heavy duty, Grade 1 door closers are ideal for schools, hospitals, and other high use environments they have been installed in these locations all over the globe.

With Hager, you get a door closer that's packaged with everything needed for quick installation, regardless of the application. Hager door closers are tri-packed for mounting three ways: parallel arm, regular arm, and top jamb. They are non-handed, packaged with a parallel arm bracket, self-drilling screws and thru-bolts at no extra charge, and adjustable for various door sizes.

Surface door closers are easy to install, with only a few holes for the body and the arm, requiring a minimum amount of preparation of the door and frame.

## Table of Contents

General Information .....	2	<b>5400 Series .....</b>	<b>29</b>
		How to Order .....	30
<b>5100 Series .....</b>	<b>5</b>	Applications .....	31
How to Order .....	6	Grade 2 Standard Surface Door Closer .....	32
Applications .....	7	Arms .....	33
Grade 1 Heavy Duty Surface Door Closer .....	8	Accessories .....	33
Arms .....	9		
Accessories .....	10	<b>Electromagnetic Holders .....</b>	<b>35</b>
		Performance Data .....	36
<b>5200 Series .....</b>	<b>13</b>	Grade 1 Heavy Duty Commercial .....	37
How to Order .....	14	Accessories .....	39
Applications .....	15		
Grade 1 Heavy Duty Surface Door Closer .....	16	<b>Overhead Door Holders and Stops .....</b>	<b>41</b>
Arms .....	17	Methods of Installation .....	42
Accessories .....	18	How to Order .....	43
		6000 Series Grade 2 Standard Duty .....	45
<b>5300 Series .....</b>	<b>21</b>	6000 Series Accessories .....	46
How to Order .....	22	7000 Series Grade 1 Heavy Duty .....	47
Applications .....	23	7000 Series Accessories .....	48
Grade 1 Heavy Duty Surface Door Closer .....	24		
Arms .....	25		
Accessories .....	26		

## GENERAL INFORMATION

Surface door closers are easy to install, with only a few holes for the body, the arm and the bracket, requiring a minimum amount of preparation of the door and frame.

There are a number of factors to consider when choosing how to mount your closer. These factors can be influenced by aesthetics, environment, or application. The main things to consider when defining how to mount a surface door closer include:

- Architectural appearance
- Accessibility to the closer arm
- Space limitations of the frame above the door
- Space limitations on the top rail of the door
- Closer position on the door

There are three basic methods of mounting surface door closers to the door and frame: regular arm, parallel arm, and top jamb mounts. All Hager door closers are supplied standard with a tri-pack for mounting any of the three types of applications. The package includes regular, parallel, and top jamb arm mounts.

### Regular Arm

The regular arm application is used when there is ample room on the top rail of the door and you are not concerned about the arm extending out away from the door. The closer body is mounted on the hinge side of the top rail of the door. The forearm is then mounted to the frame face by a mounting shoe. The arm projects at approximately a 90° angle away from the door. The regular arm mount will make the closer more power-efficient than the parallel arm or top jamb mount.

### Parallel Arm

The height dimension of the top rail is an important consideration when using this application. The closer body is mounted on the top rail of the push side of the door. The forearm is mounted by a parallel arm bracket to the soffit of the frame. The arm is parallel to the door, which makes it less likely to be damaged and aids in the overall aesthetics. The efficiency of the closer may be reduced by the mounting applications.

### Top Jamb

This is the preferred method of mounting a closer if you are faced with a narrow rail on a door. The closer body is mounted to the frame face above the push side of the door. The forearm is then mounted to the top rail of the door. The top jamb mount is more power-efficient than the parallel arm application.

## DOOR CLOSER SIZING CHART

### Exterior (and Vestibule) Door Width

#### Minimum Door Width (24")

	24" (610 mm)	30" (762 mm)	36" (914 mm)	42" (1067 mm)	48" (1219 mm)
Regular Arm & Top Jamb	Size 3	Size 4	Size 5	Size 6	
Parallel Arm	Size 3	Size 4	Size 5	-	

### Interior Door Width

#### Minimum Door Width (24")

	24" (610 mm)	30" (762 mm)	34" (865 mm)	38" (965 mm)	48" (1219 mm)	54" (1372 mm)	60" (1524 mm)
Regular Arm & Top Jamb	Size 1	Size 2	Size 3	Size 4	Size 5	Size 6	
Parallel Arm	Size 1	Size 2	Size 3	Size 4	Size 5	-	

## GENERAL INFORMATION

### Door Handing

Hager Companies' surface door closers are all non-handed, meaning they can be placed on a door so that they will operate a left-opening or a right-opening door. Some of the accessories that can be ordered with these closers are handed and the hand of the door should be specified when ordering a closer with these components.

### Closer Sizing

The American National Standards Institute (ANSI) has set the standard for sizing and has ensured that each manufacturer's closers are tested to the same standards. The door closer sizing chart on page 4 shows the closer size required to fit your door size and application.

### Meeting ADA Requirements

Doors and doorways that are non-labeled and part of an accessible route shall comply with Section 404 of the ANSI 117.1 standard. Door closers shall be adjusted so that from the open position of 90°, the time required to move the door to an open position of 12° shall be 5 seconds minimum. The maximum force for pushing open or pulling open an interior hinged door (other than a fire door) is five pounds.

### Fire Doors

Fire doors shall have the minimum opening force allowable by the appropriate authority having jurisdiction.

### Closer Adjustment

All Hager Companies' door closers are equipped with key control valves that allow for easy adjustments while decreasing the chances for tampering.

### Sweep and Latching Speeds

Two separate valves control the closing speed of the door. The sweep speed controls the speed of the door from full opening to within approximately 2° to 10° of the closed position. The latching speed valve controls the speed of the door from approximately 2° to 10° to full closing.

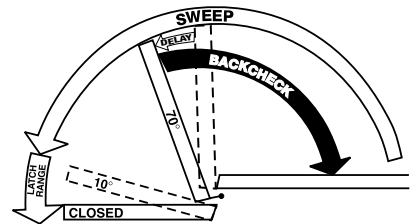

### Backcheck

Backcheck starts at approximately 70° door opening and slows the door as it opens. This feature is not to be used as a positive stop. An auxiliary stop must be used.

### Delayed Action

The delayed action feature is available for the 5100, 5200 and 5300 Series closers. The closing time between 90° and 70° shall be a minimum of 20 seconds, but is adjustable to be even slower.

### Adjustable Spring Feature

The 5100, 5200 and 5300 Series closers offer an adjustable spring feature for sizes 1-6. Spring power of the closer can be increased or decreased by turning the power adjustment shaft clockwise.

### Use of Door Stops

It is important to use an auxiliary door stop in order to protect the wall, trim, door, and closer. A stop should be used even when a closer with backcheck is used.

### How to Select the Proper Closer

- Size and Weight of Door:** 5100, 5200 and 5300 Series closers are non-sized so that closing force can be adjusted in the field to accommodate various door sizes, weights, and applications.
- Interior Application:** Where possible, the standard regular arm application should be used as it is the most efficient in terms of power and control.
- Exterior Application:** Exterior doors require greater closing forces because of draft and wind conditions. Therefore, where possible, use an extra heavy duty arm for these applications.
- Degree of Opening:** The closer should permit the door to open far enough to allow for easy traffic flow. The selection of the proper arm and position on the door are very important.
- Function:** Closers can be equipped with special arms that can serve many functions such as hold open, positive stop, or hold open stop when necessary.
- Abusive Environment:** Closers can be equipped with extra heavy duty arms that can withstand vandalism and extreme use.



# 5100 Series



5100 Series Closers are heavy duty door closers constructed of cast iron to be installed on exterior and interior doors that are subject to high use and potential abuse. They are designed and engineered for reliability and superior performance. The commercial applications ideal for these closers include schools, medical facilities, institutions and hospitals as well as office buildings and any entrance door with high foot traffic.

5100 Series Closers have a full rack and pinion operation, with a heat treated steel piston and triple heat treated steel spindle. The closers are non-handed to permit installation on doors of either hand. The sizing is adjustable from size 1 through size 6. These design features make this closer the ideal choice for doors with a maximum weight of 330 lbs.

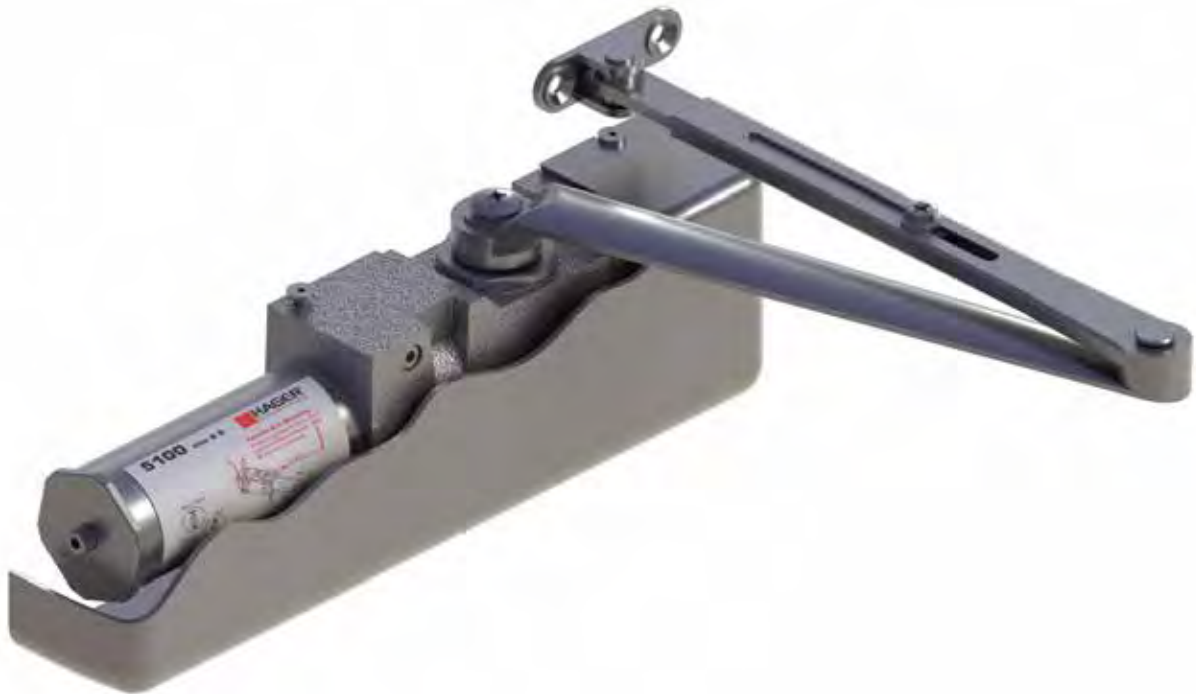

## 5100 SERIES - HOW TO ORDER

### 5100    PAR    1-6    ALM    HD    FC    RH    SX1G    DLY

<p><b>Product Group</b> 5100 - Cast Iron, Grade 1</p>	<p><b>Mount</b> MLT - Multi-Mount PAR - Parallel Arm Mount TRK -Track Arm Mount</p>	<p><b>Size</b> 1-6 Adjustable</p>	<p><b>Finish</b> ALM - Sprayed Aluminum BRZ - Sprayed Bronze DBZ - Sprayed Dark Bronze GOL - Sprayed Gold</p>	<p><b>Arm Options</b> HD - Extra Heavy Duty Arm HO - Hold Open Arm HDHO - Extra Heavy Duty Hold Open Arm LA - Long Arm HDHOS - Extra Heavy Duty Hold Open Stop Arm HDHOCS - Extra Heavy Duty Hold Open Cushion Stop Arm HDS - Extra Heavy Duty Stop Arm HDCS - Extra Heavy Duty Cushion Stop Arm HOTA - Hold Open/Stop Track Arm NHOTA - Non Hold Open Stop Track Arm DEHOTA - Double Egress HO Stop Track Arm DENHOTA - Double Egress Non-HO Stop Track Arm</p>	<p><b>Covers</b> FC - Full Cover MC - Metal Cover</p>	<p><b>Handing Options</b> RH - Right Hand LH - Left Hand <b>(specify when ordering 5108)</b></p>	<p><b>Fastener Options</b> SX1G - Sex Bolts for 1-3/8" Door SX1N - Sex Bolts for 1-3/4" Door SX2 - Sex Bolts for 2" Door SX2D - Sex Bolts for 2-1/4" Door</p>	<p><b>Miscellaneous</b> DLY - Delayed Action</p>
---	---	---------------------------------------	---	--	---	--	---	--

## 5100 SERIES - APPLICATIONS

### REGULAR ARM MOUNT (PULL SIDE)

Opening:	Templating allows up to 120°
Hold Open:	Hold open points from 90° up to 120° with hold open arm
Frame Face:	1-1/4" (32 mm) minimum
Ceiling Clearance:	1-1/4" (32 mm) minimum
Top Rail:	<ul style="list-style-type: none"> <li>• Less than 3-3/4" (95 mm) requires drop plate, 5109</li> <li>• Drop plate requires 2" (51 mm) minimum</li> </ul>
Top Rail Clearance:	4" (102 mm) from the top of door

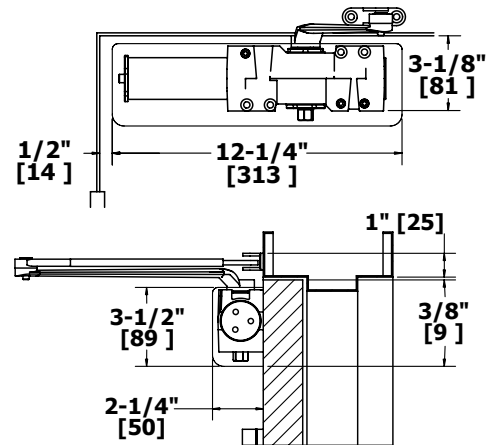

### PARALLEL ARM MOUNT (PUSH SIDE)

Opening:	Templating allows up to 180°
Hold Open:	Hold open points from 90° up to 180° with hold open arm
Top Rail:	<ul style="list-style-type: none"> <li>• Standard hollow metal 5/8" frame stop</li> <li>• Less than 5-1/2" (140 mm) from the stop requires drop plate, 5110</li> <li>• Drop plate requires 2" (51 mm) minimum from the stop</li> </ul>
Top Rail Clearance:	6-1/4" (159 mm) from the top of door

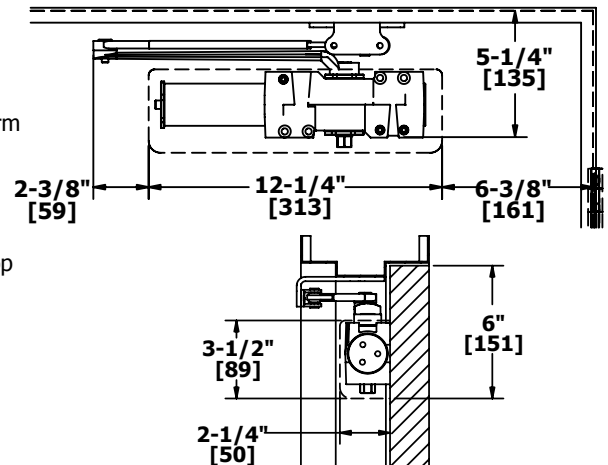

### TOP JAMB MOUNT (PUSH SIDE)

Opening:	Templating allows up to 120°
Hold Open:	Hold open points 85° up to 120° with hold open arm
Frame Face:	Less than 3-1/2" (89 mm) requires drop plate, 5115
Ceiling Clearance:	Drop plate requires 4" (102 mm) minimum
Top Rail:	Requires 1-3/8" (35 mm) minimum
Top Rail Clearance:	1-1/2" (38 mm) from the top of the door

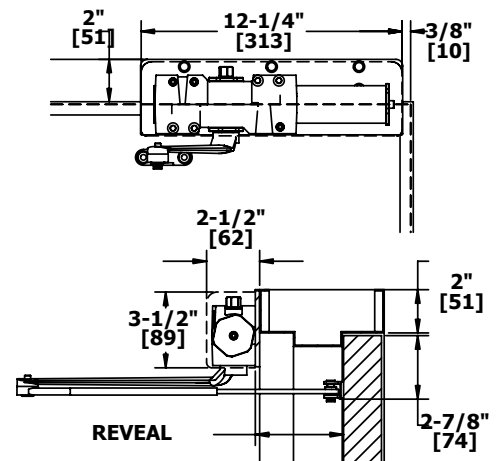



## 5100 SERIES - GRADE 1 HEAVY DUTY SURFACE DOOR CLOSER

### WARRANTY

Lifetime warranty - 330 lbs. maximum door weight

### FEATURES

- Ideal for schools, hospitals, and other high-use environments
- Standard package contains 5101 closer body, 5102 closer cover, 5103 main arm assembly, 5104 standard screw pack, 5909 parallel arm bracket, and 5940 SNB screw pack for 1-3/4" (44 mm) doors

### Certification:

- BHMA Certified ANSI A156.4, adjustable sizes 1 to 6
- ADA Compliant ANSI A117.1 Accessibility Code
- UL/cUL listed for up to 3 hours
- UL10C Positive Pressure Rated
- UL10B Neutral Pressure Rated

### Covers:

- Full plastic cover - Standard
- Plated metal cover - Optional

### Closer Body:

- Cast iron
- The recommended temperature for prolonged use is between -40° F (-42° C) & 150° F (66° C)

### Springs:

- One piece seamless steel spring tube
- Double heat treated steel, tempered springs

### Valves:

- Adjustable latching and sweep speed valves
- Adjustable backcheck valve - Standard
- Delayed action valve - Optional
- Staked valves - Standard

### Handing:

Non-handed

### Arms & Brackets:

Tri-Pack: Regular, Parallel Arm, Top Jamb Mount - Standard



### SPECIFICATIONS

#### Door Thickness:

- 1-3/4" (44 mm) - Standard
- 1-3/8" - 2-1/4" (36 mm - 57 mm) thick door - Optional

#### Fasteners:

- Self-reaming, self-tapping wood and machine screws
- Sex nuts and bolts

#### Notes:

- Full rack and pinion operation
- Precision machined, heat treated steel piston
- Triple heat treated steel spindle
- Special templates available upon request by contacting Hager Companies Customer Service

### FINISHES

- ALM, BRZ, DBZ, GOL
- Rust inhibiting primer - Standard



## 5100 SERIES - ARMS



### 5103

#### Main Arm

- Non-handed
- Forged steel
- Mounts regular, parallel arm, or top jamb mount
- Add 5909 bracket for parallel arm mount



### 5106

#### Extra Heavy Duty Arm

- Non-handed parallel arm
- Forged steel



### 5107

#### Hold Open Arm

- Non-handed
- Forged steel
- Mounts pull side or top jamb with shallow reveal
- Friction hold open function
- Add 5909 bracket for parallel arm mount



### 5108

#### Extra Heavy Duty Hold Open

- Handed parallel arm (specify handing when ordering)
- Forged steel
- Provides friction hold open function
- Adjustable at the shoe
- Not for use on fire rated doors



### Track Arm

- Non-handed
- Extruded aluminum track
- Steel arm

#### Functions:

#### Non Hold Open Stop Arms

- 2-659-0187 - ALM
- 2-659-0188 - BRZ
- 2-659-0189 - DBZ
- 2-659-0190 - GOL

#### Hold Open Stop Arms

- 2-659-0195 - ALM
- 2-659-0196 - BRZ
- 2-659-0197 - DBZ
- 2-659-0198 - GOL



### 5125

#### Extra Heavy Duty Stop Arm

- Non-handed parallel arm
- Forged steel
- Auxiliary stop in soffit shoe



### 5954

#### Extra Heavy Duty Hold Open Cushion Stop Arm

- Non-handed parallel arm
- Forged steel
- Plunger hold open function
- Contains 5961 arm and 5950 spring cushion
- Not for use on fire-rated doors



### 5955

#### Extra Heavy Duty Cushion Stop Arm

- Non-handed parallel arm
- Forged steel
- Contains 5125 arm and 5950 spring cushion



### 5961

#### Extra Heavy Duty Hold Open Stop Arm

- Non-handed parallel arm
- Forged steel
- Auxiliary stop in soffit shoe
- Plunger hold open function
- Not for use on fire-rated doors

#### Double Egress Non Hold Open Stop Arms

- 2-659-0203 - ALM
- 2-659-0204 - BRZ
- 2-659-0205 - DBZ
- 2-659-0206 - GOL

#### Double Egress Hold Open Stop Arms

- 2-659-0207 - ALM
- 2-659-0208 - BRZ
- 2-659-0209 - DBZ
- 2-659-0210 - GOL

## 5100 SERIES - ACCESSORIES



### 5101 Closer Body Only

- Cast iron
- Heat treated steel spindle and piston
- Full rack and pinion operation



### 5102 Plastic Cover

- Cover projects 2-1/4" (57 mm) from door face
- High impact non-corrosive full cover
- Secured by two machine screws



### 5109 Drop Plate - Regular Arm Mount

- Required for pull side mount when top rail is less than 3-3/4" (95 mm)
- Plate requires 2" (51 mm) minimum top rail
- Includes screw pack



### 5110 Drop Plate - Parallel Arm Mount

- Required for parallel arm mount when top rail is less than 5-1/2" (140 mm), measured from the stop to the reveal
- Plate requires 2-1/2" (6 mm) minimum top rail
- Includes screw pack



### 5111 Extra Heavy Duty Parallel Arm Support Bracket

- For use with stop arms when reveal is less than 3-1/16" (78 mm)
- Provides anchor for fifth screw



### 5112 Long Rod and Shoe

- Non-handed
- Use for door reveals greater than 3" (76 mm) and up to 5" (127 mm)
- Cast steel
- Use for top jamb application



### 5113 Blade Stop Spacer

- Required to lower parallel arm shoe to clear 1/2" (13 mm) blade stop of aluminum frames
- Includes screw pack



### 5114 Drop Plate - Low Clearance

- For use when ceiling clearance prevents normal top jamb mounting
- For use when overhead door holder prevents normal top jamb mounting
- Includes screw pack



### 5115 Drop Plate - Top Jamb Mount

- Plate requires 1-3/4" (44 mm) minimum frame face
- Required for top jamb when frame face is less than 3-1/2" (89 mm)
- For use with plastic cover
- Includes screw pack



### 5909 Parallel Arm Bracket

- Can be used to convert regular or top jamb arm to parallel arm application
- Includes screw pack



### 5935 Extra Clearance Parallel Arm Bracket

- Allows for up to 2" (51 mm) of clearance to mount additional hardware such as overhead door stops and holders
- Provides needed clearance not achieved with standard soffit plate
- Includes screw pack



### 5950 Spring Cushion

- Non-handed
- Mounts to soffit shoe of 5125, 5961, 5906, and 5907 arms
- For use with extra heavy duty hold open and stop arms for abusive applications



### 5962 Metal Cover

- Cover projects 2-1/4" (56 mm) from door face
- Cast zinc
- Secured by two machine screws

## 5100 SERIES - SCREW PACKS FOR 5100 SERIES ONLY



### 5104

#### Screw Pack - Standard

- Self-drilling wood screws
- Self-drilling machine screws



### 5940

#### SNB Screw Pack - Standard

- Sex nuts and bolts for 1-3/4" (44 mm) doors
- Machine screws



### 5941

#### SNB Screw Pack - Optional

- Sex nuts and bolts for 1-3/8" (35 mm) doors
- Machine screws



### 5942

#### SNB Screw Pack - Optional

- Sex nuts and bolts for 2" (51 mm) doors
- Machine screws



### 5943

#### SNB Screw Pack - Optional

- Sex nuts and bolts for 2-1/4" (56 mm) doors
- Machine screws



### 5946

#### Tork Security Screw Pack - Optional

- Tamper resistant torx screws with pins
- Sex nuts and bolts for 1-3/4" (44 mm) doors



# 5200 Series



5200 Series Closers are engineered and designed to offer the ideal combination of appearance and reliability. The 5200 Series Closers are constructed of aluminum alloy to be installed on exterior and interior doors. They are designed and engineered for reliability and superior performance. The commercial applications ideal for these closers include schools, medical facilities, institutions and hospitals as well as office buildings and any entrance door with high foot traffic.

5200 Series Closers have a full rack and pinion operation, with a heat treated steel piston and triple heat treated steel spindle. The closers are non-handed to permit installation on doors of either hand. The sizing is adjustable from size 1 through size 6. These design features make this closer the ideal choice for doors with a maximum weight of 250 lbs.



## 5200 SERIES - HOW TO ORDER

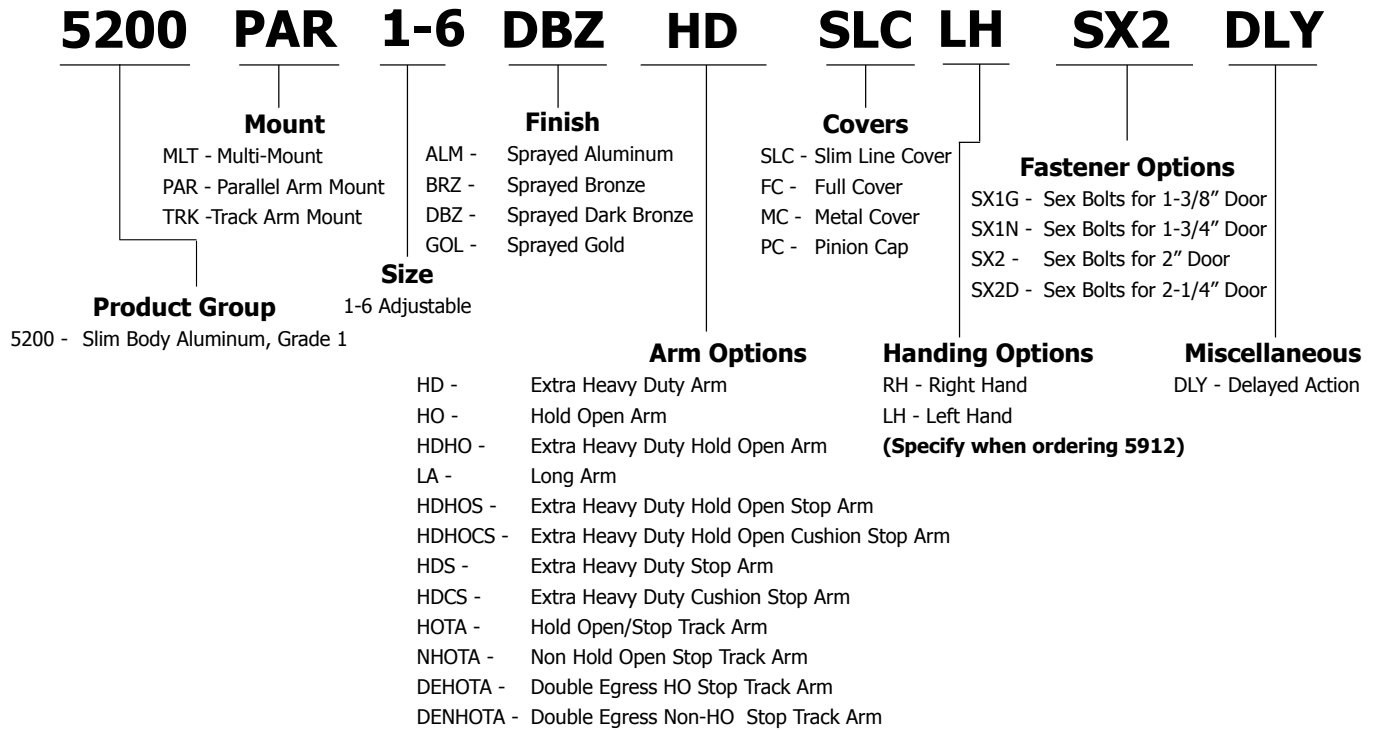

## 5200 SERIES - APPLICATIONS

### REGULAR ARM MOUNT (PULL SIDE)

Opening:	Templating allows up to 180°
Hold Open:	Hold open points 90° up to 180° with hold open arm
Frame Face:	1-3/8" (35 mm)
Ceiling Clearance:	<ul style="list-style-type: none"> <li>• 1-3/4" (45 mm) minimum</li> <li>• 1-5/8" (41 mm) minimum for hold open arm</li> </ul>
Top Rail:	<ul style="list-style-type: none"> <li>• 2-1/2" (64 mm) minimum without drop plate</li> <li>• 1-5/8" (38 mm) minimum with drop plate, 5918</li> </ul>
Top Rail Clearance:	3-1/2" (89 mm) minimum

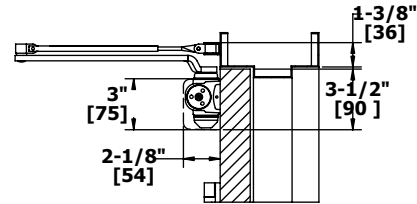
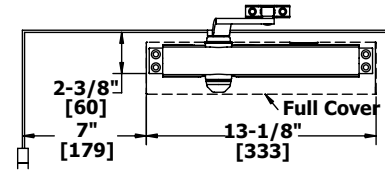

### PARALLEL ARM MOUNT (PUSH SIDE)

Opening:	Templating allows up to 180°
Hold Open:	Hold open points 90° up to 180° with hold open
Top Rail:	<ul style="list-style-type: none"> <li>• Standard hollow metal 5/8" frame stop</li> <li>• 5-3/8" (137 mm) minimum</li> </ul>
Top Rail Clearance:	6-1/4" (159 mm) minimum

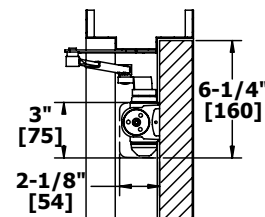
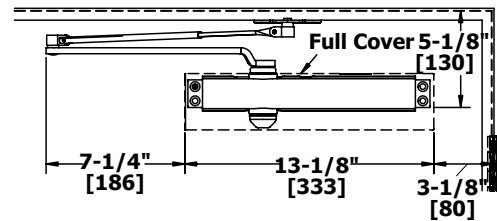

### TOP JAMB MOUNT (PUSH SIDE)

Opening:	Templating allows up to 180°
Hold Open:	Hold open points 90° up to 180° with hold open
Frame Face:	<ul style="list-style-type: none"> <li>• 1-7/8" (48 mm) minimum</li> <li>• 1-1/8" (29 mm) minimum with drop plate, 5918</li> </ul>
Ceiling Clearance:	<ul style="list-style-type: none"> <li>• 2-3/4" (70 mm) minimum</li> <li>• 1-5/8" (41 mm) minimum with drop plate, 5918</li> </ul>
Top Rail:	2" (51 mm) minimum
Top Rail Clearance:	<ul style="list-style-type: none"> <li>• 2-1/4" (57 mm) minimum</li> <li>• 2-1/2" (64 mm) minimum for hold-open</li> <li>• 3-3/8" (86 mm) minimum with drop plate, 5918</li> <li>• 3-5/8" (92 mm) minimum for hold open with drop plate</li> </ul>

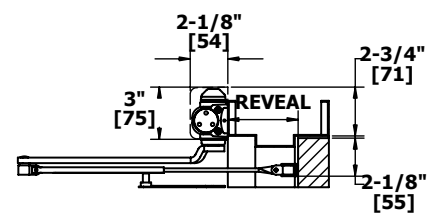
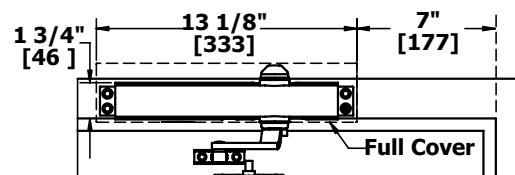



## 5200 SERIES - GRADE 1 HEAVY DUTY SURFACE DOOR CLOSER

### WARRANTY

Lifetime warranty - 250 lbs. maximum door weight

### FEATURES

- Ideal for schools, hospitals, and other high-use environments
- Standard package contains 5201 closer body, 5202 closer cover, 5203 main arm assembly, 5204 standard screw pack, 5900 parallel arm bracket, and 5902 SNB screw pack for 1-3/4" (44 mm) doors

### Certification:

- BHMA Certified ANSI A156.4, adjustable sizes 1 to 6
- ADA Compliant ANSI A117.1 Accessibility Code
- UL/cUL Listed for up to 3 hours
- UL10C Positive Pressure Rated
- UL10B Neutral Pressure Rated

### Covers:

- Full plastic cover - Standard
- Full size plated metal cover - Optional

### Closer Body:

- Aluminum alloy
- The recommended temperature for prolonged use is between -40° F (-42° C) & 150° F (66° C)

### Springs:

Double heat treated steel, tempered springs

### Valves:

- Adjustable latching and sweep speed valves
- Adjustable backcheck valve - Standard
- Delayed action valve - Optional
- Staked valves - Standard

### Handing:

Non-handed

### Arms & Brackets:

- Tri-Pack: Regular, Parallel Arm, and Top Jamb Mount - Standard
- 15% power adjustment in standard arm for regular and top jamb mount



### SPECIFICATIONS

#### Door Thickness:

- 1-3/4" (44 mm) - Standard
- 1-3/8" - 2-1/4" (36 mm - 57 mm) thick door - Optional

#### Fasteners:

- Self-reaming, self-tapping wood and machine screws
- Sex nuts and bolts

#### Notes:

- Full rack and pinion operation
- Precision machined, heat treated steel piston
- Triple heat treated steel spindle
- Special templates available upon request by contacting Hager Companies Customer Service

### FINISHES

- ALM, BRZ, DBZ, GOL
- Rust inhibiting primer - Standard

## 5200 SERIES - ARMS



### 5203

#### Main Arm

- Non-handed
- Forged steel
- Mounts regular, parallel arm, or top jamb mount
- Add 5900 bracket for parallel arm mount



### 5207

#### Hold Open Arm

- Non-handed
- Forged steel
- Mounts pull side or top jamb with shallow reveal
- Friction hold open function
- Add 5914 bracket for parallel arm mount



### 5906

#### Extra Heavy Duty Hold Open Stop Arm

- Non-handed parallel arm
- Forged steel
- Plunger hold open function
- Auxiliary stop in soffit shoe
- For use with 5200 and 5300 Series closers



### 5907

#### Extra Heavy Duty Stop Arm

- Non-handed parallel arm
- Forged steel
- Auxiliary stop in soffit shoe
- For use with 5200 and 5300 Series closers



#### Track Arm

- Non-handed
- Extruded aluminum track
- Steel arm

#### Functions:

#### Non Hold Open Stop Arms

- 2-659-0191 - ALM
- 2-659-0192 - BRZ
- 2-659-0193 - DBZ
- 2-659-0194 - GOL

#### Hold Open Stop Arms

- 2-659-0199 - ALM
- 2-659-0200 - BRZ
- 2-659-0201 - DBZ
- 2-659-0202 - GOL



### 5911

#### Extra Heavy Duty Arm

- Non-handed parallel arm
- Forged steel



### 5912

#### Extra Heavy Duty Hold Open

- Handed parallel arm (specify handing when ordering)
- Forged steel
- Provides friction hold open function
- Adjustable at the shoe
- For use with 5200 and 5300 Series closers
- Not for use on fire-rated doors



### 5956

#### Extra Heavy Duty Hold Open Cushion Stop Arm

- Non-handed parallel arm
- Forged steel
- Plunger hold open function
- Contains 5906 arm and 5950 spring cushion arm
- For use with 5200 and 5300 Series closers



### 5957

#### Extra Heavy Duty Cushion Stop Arm

- Non-handed parallel arm
- Forged steel
- Contains 5907 arm and 5950 spring cushion
- For use with 5200 and 5300 Series closers

#### Double Egress Non Hold Open Stop Arms

- 2-659-0211 - ALM
- 2-659-0212 - BRZ
- 2-659-0213 - DBZ
- 2-659-0214 - GOL

#### Double Egress Hold Open Stop Arms

- 2-659-0215 - ALM
- 2-659-0216 - BRZ
- 2-659-0217 - DBZ
- 2-659-0218 - GOL

## 5200 SERIES - ACCESSORIES



### 5201

#### Closer Body Only

- Aluminum alloy
- Heat treated steel spindle and piston
- Full rack and pinion operation



### 5202

#### Full Plastic Cover

- Cover projects 2-3/16" (56 mm) from door face
- High impact non-corrosive full cover
- Secured by two machine screws



### 5900

#### Parallel Arm Bracket

- Can be used to convert regular or top jamb arms to parallel arm application
- For use with 5200, 5300 and 5400 Series arms



### 5908

#### Long Rod and Shoe

- Use for reveals greater than 4" (102 mm) and up to 8" (203 mm)
- Non-handed
- Cast steel
- Use for top jamb application
- For use with 5200, 5300 and 5400 Series arms
- Includes screw pack



### 5913

#### Blade Stop Spacer

- Required to lower parallel arm shoe to clear 1/2" (13 mm) blade stop of aluminum frames
- For use with 5200, 5300 and 5400 Series arms
- Includes screw pack



### 5914

#### Hold Open Parallel Arm Bracket

- Supplied with all standard hold open arms
- For use with 5200, 5300 and 5400 Series arms
- Includes screw pack



### 5918

#### Drop Plate - Top Jamb, Narrow Top Rail

- For use with slim line cover
- For use when a narrow top rail prevents mounting directly to door surface
- For use when low ceiling clearance prevents normal top jamb mounting
- Includes screw pack



### 5919

#### Pinion Cap

- High-impact, non-corrosive
- Fits over the pinion and extends 9/16" (14 mm)
- For use with slim line cover



### 5920

#### Slim Line Plastic Cover

- Cover projects 2-3/16" (56 mm) from the door face
- High-impact non-corrosive slim line cover
- Secured by two machine screws
- Available in plastic only



### 5921

#### Drop Plate - Narrow Top Rail

- For use with a full cover
- For use when a narrow top rail prevents mounting directly to door surface
- Includes screw pack



### 5922

#### Drop Plate - Top Jamb, Parallel Arm

- For use with slim line cover
- For use when low ceiling clearance prevents normal top jamb mounting; with full cover
- For use when an overhead door holder prevents normal top jamb mounting
- Includes screw pack



### 5923

#### Drop Plate - Parallel Arm

- For use with a full cover
- For use with a parallel arm when narrow top rail prevents mounting directly to the door surface
- Includes screw pack

## 5200 SERIES - ACCESSORIES

## SCREW PACKS



### 5932

#### Metal Cover

- Cover projects 2-1/4" (57 mm) from door face
- Cast zinc full cover
- Secured by two machine screws
- Not offered as slim line



### 5936

#### Extra Clearance Parallel Arm Bracket

- Allows for up to 2" (51 mm) of clearance to mount additional hardware such as overhead door stops and holders
- Provides needed clearance not achieved with a standard soffit plate



### 5950

#### Spring Cushion

- Non-handed
- Mounts to soffit shoe of 5125, 5961, 5906 and 5907 arms
- For use with extra heavy duty hold open and stop arms for abusive applications



### 5204

#### Screw Pack - Standard

- Self-drilling wood screws
- Self-drilling machine screws
- For 5200 Series closer



### 5902

#### SNB Screw Pack - Standard

- Sex nuts and bolts for 1-3/4" (44 mm) doors
- Machine screws
- For use with 5200, 5300, 5400 Series closers only



### 5903

#### SNB Screw Pack - Optional

- Sex nuts and bolts for 1-3/8" (35 mm) doors
- Machine screws
- For use with 5200, 5300, 5400 Series closers only



### 5904

#### SNB Screw Pack - Optional

- Sex nuts and bolts for 2" (51 mm) doors
- Machine screws
- For use with 5200, 5300, 5400 Series closers only



### 5905

#### SNB Screw Pack - Optional

- Sex nuts and bolts for 2-1/4" (56 mm) doors
- Machine screws
- For use with 5200, 5300, 5400 Series closers only



# 5300 Series



The 5300 Series Closers offer a compact design for a variety of applications. They are constructed of aluminum alloy to withstand the use and abuse you come to expect of Hager Companies Grade 1 products. The 5300 Series closers provide the flexibility needed to meet the many demands of both commercial and institutional applications, including the ADA barrier-free accessibility requirements. The sizing is adjustable from size 1 through size 6. These design features make this closer the ideal choice for doors with a maximum weight of 250 lbs.



## 5300 SERIES - HOW TO ORDER

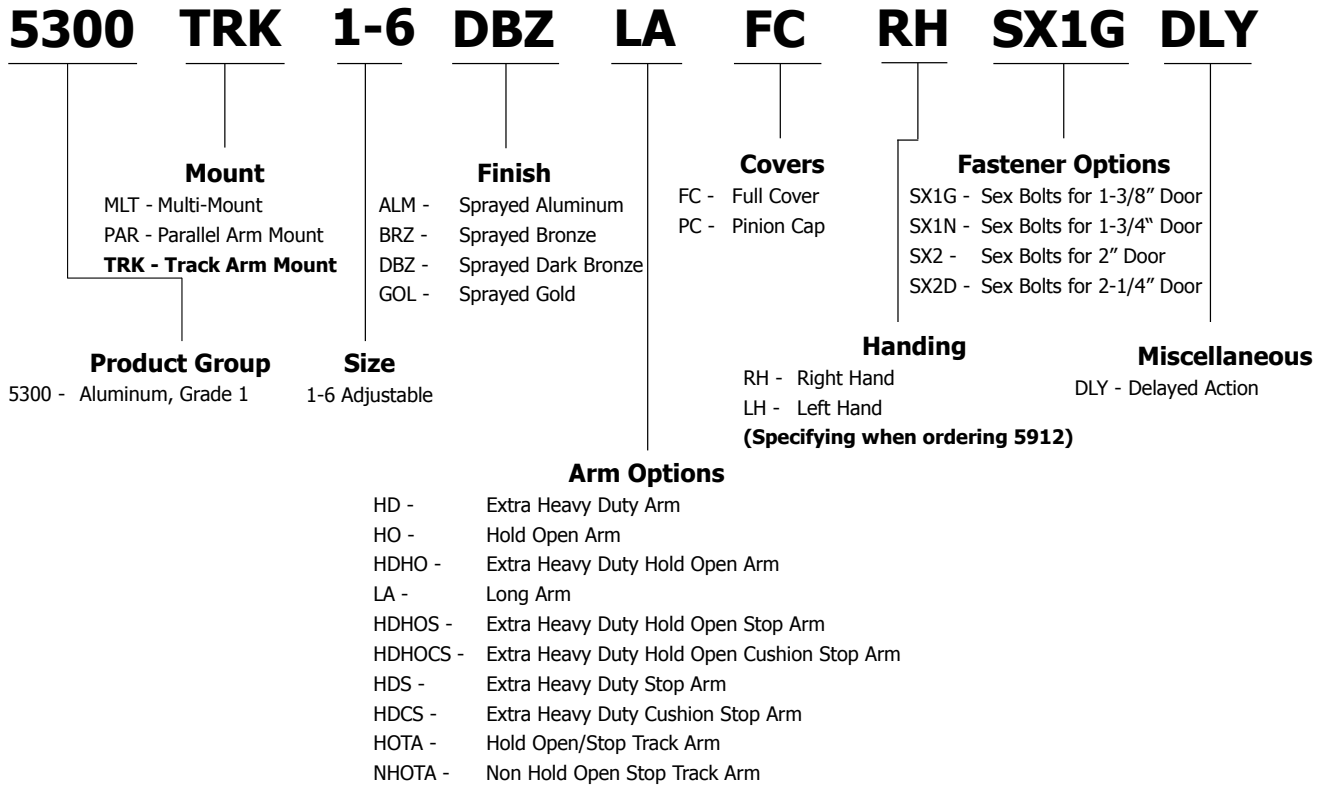

## 5300 SERIES - APPLICATIONS

### REGULAR ARM MOUNT (PULL SIDE)

Opening:	Templating allows up to 180°
Hold Open:	Hold open points 90° up to 180° with hold open arm
Frame Face:	1-3/8" (35 mm) minimum
Ceiling Clearance:	<ul style="list-style-type: none"> <li>• 1-5/8" (41 mm) minimum</li> <li>• 1-5/8" (41 mm) minimum for hold open arm</li> </ul>
Top Rail:	2-1/2" (64 mm) minimum with drop plate, 5915
Top Rail Clearance:	4-1/4" (108 mm) minimum from the top of the door

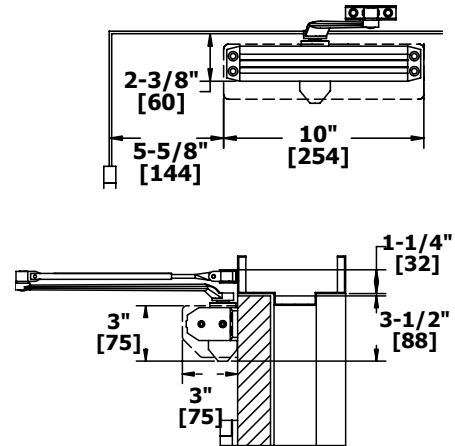

### PARALLEL ARM MOUNT (PUSH SIDE)

Opening:	Templating allows up to 180°
Hold Open:	Hold open points 90° up to 180° with hold open
Top Rail:	<ul style="list-style-type: none"> <li>• Standard hollow metal 5/8" frame stop</li> <li>• 4-3/4" (121 mm) minimum</li> <li>• 4" (102 mm) minimum with hold open</li> <li>• 3-1/8" (79 mm) minimum with plate</li> <li>• 2-1/8" (54 mm) minimum with hold open and plate</li> </ul>
Top Rail Clearance:	5-3/4" (146 mm) minimum from the top of the door

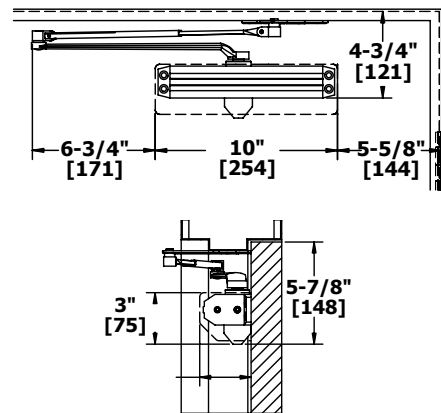

### TOP JAMB MOUNT (PUSH SIDE)

Opening:	Templating allows up to 180°
Hold Open:	Hold open points 90° up to 180° with hold open
Frame Face:	1-3/4" (45 mm) minimum
Ceiling Clearance:	<ul style="list-style-type: none"> <li>• 2-3/4" (70 mm) minimum</li> <li>• 1-3/4" (44 mm) minimum with drop plate, 5918</li> </ul>
Top Rail:	1-7/8" (48 mm) minimum
Top Rail Clearance:	<ul style="list-style-type: none"> <li>• 2-1/8" (54 mm) minimum</li> <li>• 2-3/4" (70 mm) minimum with drop plate, 5917</li> <li>• 2-1/4" (57 mm) minimum for hold open with drop plate, 5917</li> <li>• 3-5/8" (92 mm) minimum with drop plate, 5915</li> </ul>

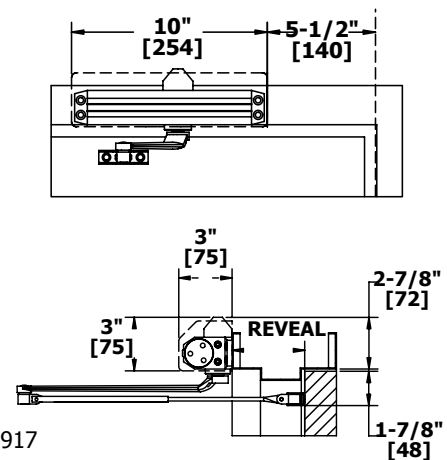



## 5300 SERIES - GRADE 1 HEAVY DUTY SURFACE DOOR CLOSER

### WARRANTY

Lifetime warranty - 250 lbs. maximum door weight

### FEATURES

- Ideal for schools, hospitals, and other high-use environments
- Standard package contains 5301 closer body, 5302 closer cover, 5902 pinion cap, 5303 main arm assembly, 5304 standard screw pack, 5900 parallel arm bracket, and 5902 SNB screw pack for 1-3/4" (44 mm) door

### Certification:

- BHMA Certified ANSI A156.4, adjustable sizes 1 to 6
- ADA Compliant ANSI A117.1 Accessibility Code
- UL/cUL Listed for up to 3 hours
- UL10C Positive Pressure Rated
- UL10B Neutral Pressure Rated

### Covers:

Full plastic cover and pinion cap - Standard

### Closer Body:

- Aluminum alloy
- The recommended temperature for prolonged use is between -40° F (-42° C) & 150° F (66° C)

### Springs:

Double heat treated steel, tempered springs

### Valves:

- Adjustable latching and sweep speed valves
- Adjustable backcheck valve - Standard
- Delayed action valve - Optional
- Staked valves - Standard

### Handing:

Non-handed

### Arms & Brackets:

- Tri-Pack: Regular, Parallel Arm, and Top Jamb Mount - Standard
- 15% power adjustment in standard arm for regular and top jamb mount

### SPECIFICATIONS

#### Door Thickness:

- 1-3/4" (44 mm) - Standard
- 1-3/8" - 2-1/4" (36 mm - 57 mm) thick door - Optional

#### Fasteners:

- Self-reaming, self-tapping wood and machine screws
- Sex nuts and bolts

#### Notes:

- Full rack and pinion operation
- Precision machined, heat treated steel piston
- Triple heat treated steel spindle
- Special templates available upon request by contacting Hager Companies Customer Service

### FINISHES

- ALM, BRZ, DBZ, GOL
- Rust inhibiting primer - Standard



## 5300 SERIES - ARMS



### 5303

#### Main Arm

- Non-handed
- Forged steel
- Mounts regular, top jamb, or parallel arm mount
- Add 5900 bracket for parallel arm mount



### 5911

#### Extra Heavy Duty Arm Assembly

- Non-handed parallel arm
- Forged steel
- For use with 5200 and 5300 Series closers



### 5307

#### Hold Open Arm Assembly

- Non-handed
- Forged steel
- Mounts pull side or top jamb with shallow reveal
- Friction hold open
- Add 5914 bracket for parallel arm mount



### 5912

#### Extra Heavy Duty Hold Open Arm Assembly

- Handed parallel arm (specify handing when ordering)
- Forged steel
- Provides friction hold open function
- Adjustable at the shoe
- For use with 5200 and 5300 Series closers
- Not for use on fire-rated doors



### 5906

#### Extra Heavy Duty Hold Open Stop Arm

- Non-handed parallel arm
- Forged steel
- Plunger hold open function
- Auxiliary stop in soffit shoe
- For use with 5200 and 5300 Series closers
- Not for use on fire-rated doors



### 5956

#### Extra Heavy Duty Hold Open Cushion Stop Arm

- Non-handed parallel arm
- Forged steel
- Contains 5906 arm and 5950 spring cushion arm
- Plunger hold open
- For use with 5200 and 5300 Series closers
- Not for use on fire-rated doors



### 5907

#### Extra Heavy Duty Stop Arm

- Non-handed parallel arm
- For use in abusive environments
- Auxiliary stop in soffit shoe
- For use with 5200 and 5300 Series closers



### 5957

#### Extra Heavy Duty Cushion Stop Arm

- Non-handed parallel arm
- Forged steel
- Contains 5907 arm and 5950 spring cushion
- For use with 5200 and 5300 Series closers



### Track Arm

- Non-handed
- Extruded aluminum track
- Steel arm

Functions:

#### Non Hold Open Stop Arms

- 2-659-0191 - ALM
- 2-659-0192 - BRZ
- 2-659-0193 - DBZ
- 2-659-0194 - GOL

#### Hold Open Stop Arms

- 2-659-0199 - ALM
- 2-659-0200 - BRZ
- 2-659-0201 - DBZ
- 2-659-0202 - GOL

## 5300 SERIES - ACCESSORIES



### 5301

#### Closer Body Only

- Aluminum alloy
- Heat treated steel spindle and piston
- Full rack and pinion operation



### 5302

#### Full Plastic Cover

- Cover projects 2-3/16" (56 mm) from door face
- High impact non-corrosive full cover - Standard
- Secured by two machine screws
- Available in plastic only



### 5900

#### Parallel Arm Bracket

- Used to convert regular or top jamb arms to parallel arm application
- For use with 5300 and 5400 Series closer arms
- Includes screw pack



### 5901

#### Pinion Cap

- High-impact, non-corrosive
- Supplied standard in 5300 and 5400 Series closers
- Fits over the pinion and extends 1" (25 mm)



### 5908

#### Long Rod and Shoe

- Use for reveals greater than 4" (102 mm) and up to 8" (203 mm)
- Non-handed
- Cast steel
- Use for top jamb application
- For use with 5300 and 5400 Series closer arms



### 5913

#### Blade Stop Spacer

- Required to lower parallel arm shoe to clear 1/2" (13 mm) blade stop of aluminum frames
- For use with 5300 and 5400 Series closer arms
- Includes screw pack



### 5936

#### Extra Clearance Parallel Arm Bracket

- Allows for up to 2" (13 mm) of clearance to mount additional hardware such as overhead door stops and holders
- Provides needed clearance not achieved with a standard soffit plate
- Includes screw pack



### 5950

#### Spring Cushion

- Non-handed
- Mounts to soffit shoe of 5125, 5961, 5906 and 5907 arms
- For use with extra heavy duty hold open and stop arms for abusive applications



### 5914

#### Hold Open Parallel Arm Bracket

- Supplied with all standard hold open arms
- For use with 5200, 5300, 5400 Series closers only
- Includes screw pack



### 5915

#### Drop Plate - Narrow Rail Overhead Holder

- For use when an overhead door holder prevents normal top jamb mounting
- For use when a narrow rail prevents the closer from being mounted directly to the door
- For use with parallel arm and no cover
- For use when low ceiling clearance prevents normal top jamb mounting
- Includes screw pack



### 5916

#### Drop Plate - Narrow Rail Parallel Arm

- For use when a narrow rail prevents the closer from being mounted directly to the door
- For use with parallel arm and full plastic cover
- Includes screw pack

## 5300 SERIES - ACCESSORIES

## SCREW PACKS



### **5917** **Drop Plate - Top Jamb, Low Clearance**

- For use with no cover
- For use when ceiling clearance is between 1-3/4" (44 mm) and 2-5/8" (67 mm)
- For use when an overhead door holder prevents normal top jamb mounting
- Includes screw pack



### **5304** **Screw Pack - Standard**

- Self-drilling wood screws
- Self-drilling machine screws
- For 5300 Series closer only



### **5902** **SNB Screw Pack - Standard**

- Sex nuts and bolts for 1-3/4" (44 mm) doors
- Machine screws
- For use with 5200, 5300, 5400 Series closers only



### **5903** **SNB Screw Pack - Optional**

- Sex nuts and bolts for 1-3/8" (35 mm) doors
- Machine screws
- For use with 5200, 5300, 5400 Series closers only



### **5904** **SNB Screw Pack - Optional**

- Sex nuts and bolts for 2" (51 mm) doors
- Machine screws
- For use with 5200, 5300, 5400 Series closers only



### **5905** **SNB Screw Pack - Optional**

- Sex nuts and bolts for 2-1/4" (56 mm) doors
- Machine screws
- For use with 5200, 5300, 5400 Series closers only



# 5400 Series



5400 Series Closers are ideal for light duty commercial applications. 5400 Series Closers have a heat treated steel piston and triple heat treated steel spindle. The closers are non-handed to permit installation on doors of either hand. These closers have fixed spring sizes. The maximum door weight for each of these closers is dependent on the size selected. Size 2 - 80 lbs, Size 3 - 135 lbs, Size 4 - 175 lbs and Size 5 - 200 lbs.



## 5400 SERIES - HOW TO ORDER

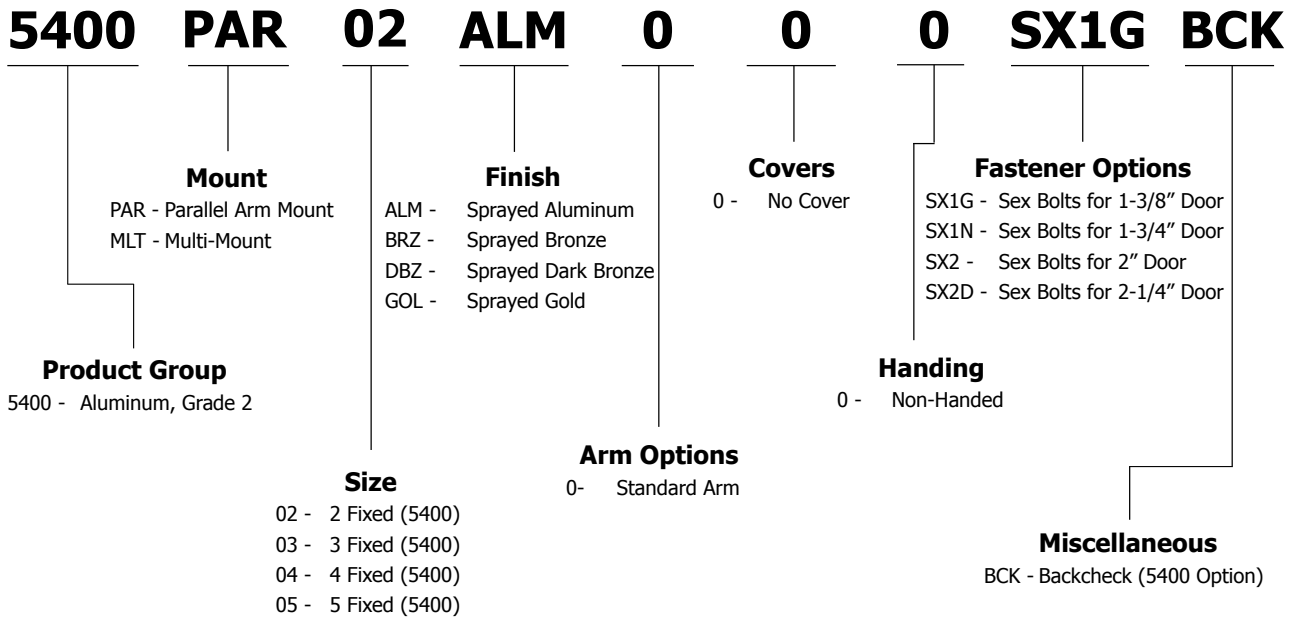

**5400 Series closers are sized 2, 3, 4 & 5.  
Must know size when placing order.**

### DOOR CLOSER SIZING CHART

#### Exterior (and Vestibule) Door Width

##### Minimum Door Width (24")

	24" (610 mm)	30" (762 mm)	36" (914 mm)	42" (1067 mm)	48" (1219 mm)
Regular Arm & Top Jamb	Size 3	Size 4	Size 5	-	-
Parallel Arm	Size 3	Size 4	Size 5	-	-

#### Interior Door Width

##### Minimum Door Width (24")

	24" (610 mm)	30" (762 mm)	34" (865 mm)	38" (965 mm)	48" (1219 mm)	54" (1372 mm)	60" (1524 mm)
Regular Arm & Top Jamb	-	Size 2	Size 3	Size 4	Size 5	Size 6	-
Parallel Arm	-	Size 2	Size 3	Size 4	Size 5	-	-



## 5400 SERIES - APPLICATIONS

### REGULAR ARM MOUNT

Opening:	Templating allows up to 180°
Frame Face:	1-1/2" (38 mm) minimum
Ceiling Clearance:	1-3/4" (44 mm) minimum
Top Rail:	2-1/4" (57 mm) minimum
Top Rail Clearance:	3-1/2" (89 mm) minimum

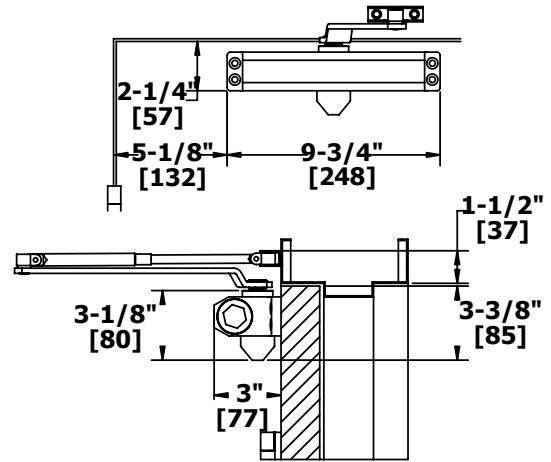

### PARALLEL ARM MOUNT

Opening:	Templating allows up to 180°
Top Rail:	<ul style="list-style-type: none"> <li>• 5/8" (16 mm) frame stop</li> <li>• 4-3/4" (121 mm) minimum</li> </ul>
Top Rail Clearance:	5-3/4" (146 mm) minimum

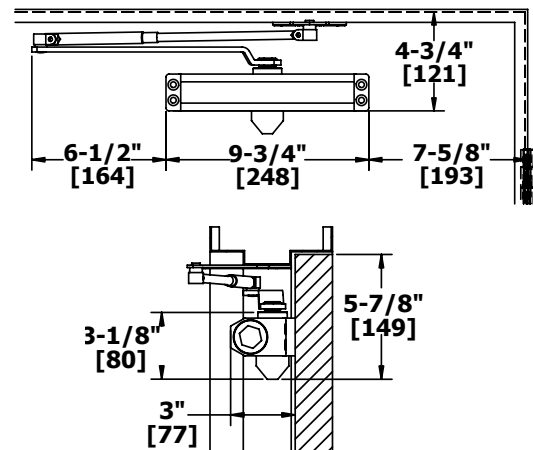

### TOP JAMB MOUNT

Opening:	Templating allows up to 180°
Frame Face:	1-3/4" (45 mm) minimum
Ceiling Clearance:	2-3/4" (70 mm) minimum
Top Rail:	1-7/8" (48 mm) minimum
Top Rail Clearance:	2-1/8" (54 mm) minimum

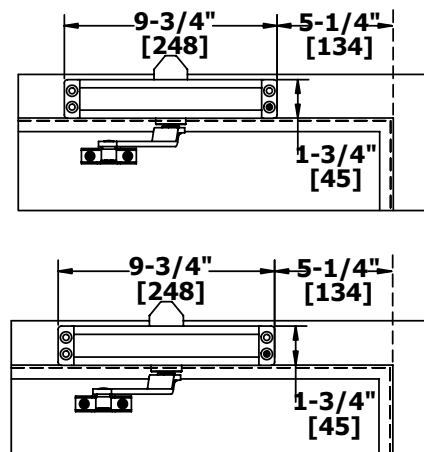



## 5400 SERIES - GRADE 2 STANDARD DUTY SURFACE DOOR CLOSER

### WARRANTY

Five-year warranty - maximum door weight size:

- 2 - 80 lbs
- 3 - 135 lbs
- 4 - 175 lbs
- 5 - 200 lbs

### FEATURES

- Ideal for light duty commercial applications
- Standard package contains 5401 closer body, 5901 pinion cap, 5403 main arm assembly, 5404 standard screw pack, 5900 parallel arm bracket, and 5902 SNB screw pack for 1-3/4" (44 mm) door



### Certification:

- BHMA Certified ANSI A156.4, Sizes 2, 3, 4, 5 - Must specify
- UL/cUL Listed for up to 3 hours
- UL10C Positive Pressure Rated
- UL10B Neutral Pressure Rated

### Covers:

Pinion cap - Standard

### Closer Body:

- Aluminum alloy
- The recommended temperature for prolonged use is between -40° F (-42° C) & 150° F (66° C)

### Springs:

Double heat treated steel, tempered springs

### Valves:

- Adjustable latching and sweep speed valves
- Adjustable backcheck valve - Optional
- Staked valves - Standard

### Handing:

Non-handed

### Arms & Brackets:

- Tri-Pack: Regular, Parallel Arm, and Top Jamb Mount - Standard
- 15% power adjustment in standard arm for regular and top jamb mount

### SPECIFICATIONS

#### Door Thickness:

- 1-3/4" (44 mm) - Standard
- 1-3/8" - 2-1/4" (36 mm - 57 mm) thick door - Optional

#### Fasteners:

- Self-reaming, self-tapping wood and machine screws
- Sex nuts and bolts

#### Notes:

- Precision machined, heat treated steel piston
- Triple heat treated steel spindle
- Special templates available upon request by contacting Hager Companies Customer Service

### FINISHES

- ALM, BRZ, DBZ, GOL
- Rust inhibiting primer - Standard



## 5400 SERIES - ARMS & ACCESSORIES

## SCREW PACKS



### 5403

#### Main Arm

- Non-handed
- Forged steel
- Mounts regular, parallel arm, or top jamb mount
- Add 5900 bracket for parallel arm mount



### 5401

#### Closer Body Only

- Aluminum alloy
- Full rack and pinion operation
- Triple heat treated steel spindle
- Sizes 2, 3, 4, and 5 available



### 5900

#### Parallel Arm Bracket

- Used to convert regular or top jamb arms to parallel arm application
- Supplied standard closers
- For use with 5200, 5300 and 5400 Series closer arms
- Includes screw pack



### 5901

#### Pinion Cap

- High-impact, non-corrosive
- Fits over the pinion and extends 1" (25 mm)
- Supplied standard



### 5913

#### Blade Stop Spacer

- Required to lower parallel arm shoe to clear 1/2" (13 mm) blade stop of aluminum frames
- For use with 5300 and 5400 Series arms
- Includes screw pack



### 5404

#### Screw Pack - Standard

- Self-drilling wood screws
- Self-drilling machine screws
- For 5400 Series closer only



### 5902

#### SNB Screw Pack - Standard

- Sex nuts and bolts for 1-3/4" (44 mm) doors
- Machine screws
- For use with 5200, 5300, 5400 Series closers only



### 5903

#### SNB Screw Pack - Optional

- Sex nuts and bolts for 1-3/8" (35 mm) doors
- Machine screws
- For use with 5200, 5300, 5400 Series closers only



### 5904

#### SNB Screw Pack - Optional

- Sex nuts and bolts for 2" (51 mm) doors
- Machine screws
- For use with 5200, 5300, 5400 Series closers only



### 5905

#### SNB Screw Pack - Optional

- Sex nuts and bolts for 2-1/4" (56 mm) doors
- Machine screws
- For use with 5200, 5300, 5400 Series closers only



# Electromagnetic Holders



Hager Companies offers a line of electromagnetic door holders with built-in protection and low residual magnetism so they release easily even in applications meeting ADA requirements with minimal spring force door closers. These features make the electromagnetic holders a great solution for both safety and convenience and are ideal solutions for applications in hotels, hospitals and nursing homes.

Hager electromagnetic holders are designed for virtually any remote door release application and are ideal for holding doors open until released by a fire alarm or switching device. When deactivated the electromagnetic holders help to control the spread of fire and smoke by the simultaneous release of doors from an open to a closed position. The electromagnetic holders can be utilized independently or with the smoke detector systems.

The electromagnetic holders include a door mounted armature and a floor or wall mounted electromagnet. The features of this hardware include: dual voltage capability, very low current draw for energy efficiency, silent operation and an adjustable catch plate.



## ELECTROMAGNETIC DOOR HOLDERS - PERFORMANCE DATA

MODEL	VOLTAGE	DC/mA	AC/mA	TERMINALS	LB.	KG.
1224	12V	40	38	C&L	30	13.6
	24V	40	36	C&H	30	13.6
24120	24V	20	19	C&L	40	18.1
	120V		20	C&H	35	15.8
24220	24V	20	19	C&L	20	9.0
	220V		15	C&H	22	9.8

MODEL	VOLTAGE	DC/mA	AC/mA	TERMINALS	LB.	KG.
1224	24V	85	81	C&L	75	34.0
24120	120V		100	C&L	110	49.8

**\*High Holding Force/Special Applications:**

To obtain the performance values in the above table, apply high listed voltage to low voltage terminals (C&L).

NOTE: This configuration can only be applied to models 1224 and 24120.

### DUAL VOLTAGE (REAR VIEW SHOWN)

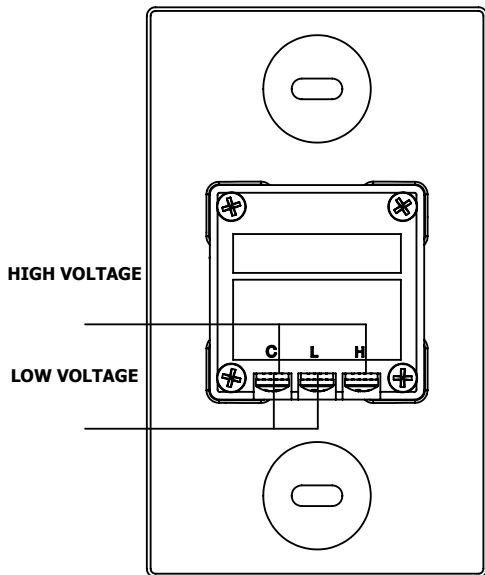

### EXTENSION ROD/ADJUSTABLE EXTENSION ROD

To calculate extension rod length needed, use the formula below based on style holder being used.

**Flush mount:** Measure distance from door to wall when held at desired opening. Subtract 3" (76 mm) to obtain extension rod length needed.

**Recessed mount:** Measure distance from door to wall when held at desired opening. Subtract 2-3/8" (60 mm) to obtain extension rod length needed.

**Surface mount:** Measure distance from door to wall when held at desired opening. Subtract 4-5/8" (117 mm) to obtain extension rod length needed.

See example below using flush mount.

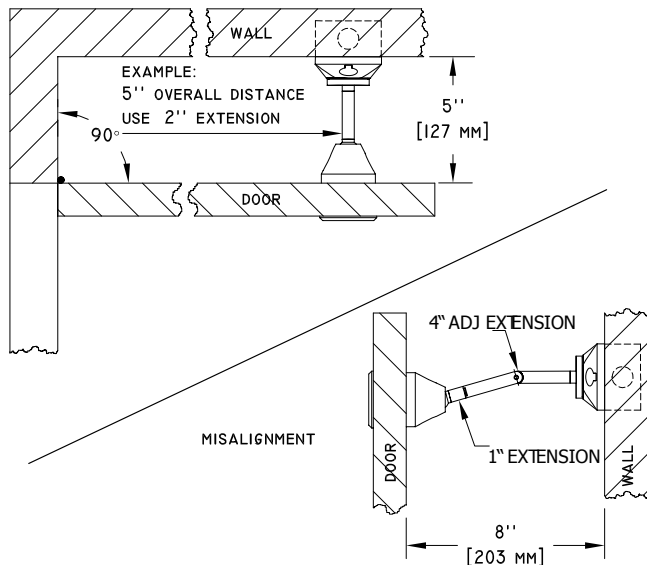



## ELECTROMAGNETIC DOOR HOLDERS - GRADE 1 HEAVY DUTY COMMERCIAL

<b>WARRANTY</b>	One-year warranty
<b>FEATURES</b>	<ul style="list-style-type: none"> <li>• Ideal for hospitals, hotels, schools, and other commercial buildings</li> <li>• Designed for use with self-closing fire and smoke barrier doors</li> <li>• Low current draw</li> <li>• Fail safe: when electrical current is interrupted, doors release to close automatically</li> </ul>
Certification:	<ul style="list-style-type: none"> <li>• UL/ULC listed</li> <li>• Meets ANSI 156.15 for C00011</li> <li>• California State Fire Marshall listed (CSFM)</li> <li>• City of New York MEA approved</li> <li>• Factory Mutual</li> </ul>
Body:	Zinc alloy
Voltages:	Standard dual voltage AC or DC inputs of 12 & 24V, 24 & 120V, 24 & 220V models
Holding Force:	Typical holding force of 25-40 pounds; performance value can be increased to 110 pounds on special applications
Mount:	Single or double coil floor, surface, flush, and recessed mount
<b>SPECIFICATIONS</b>	
Total Projection:	<ul style="list-style-type: none"> <li>• Recessed mount: 2-11/32" (60 mm)</li> <li>• Flush mount: 3-1/16" (78 mm)</li> <li>• Surface mount: 4-5/8" (117 mm)</li> <li>• Floor mount (single door): 5" (127 mm)</li> <li>• Floor mount (double door): 9-5/8" (244 mm)</li> </ul>
Fasteners:	Hardware package, mounting bracket
Notes:	<ul style="list-style-type: none"> <li>• Optional aluminum extension and misalignment rods available</li> <li>• Drill fixture available</li> <li>• Replacement armature disc and armature plate assemblies available</li> <li>• Adhesive template included</li> </ul>
<b>FINISHES</b>	US3, LS, L2



# ELECTROMAGNETIC DOOR HOLDERS - 380 SERIES HOLDERS



**380F**  
Flush Mount

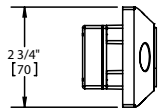
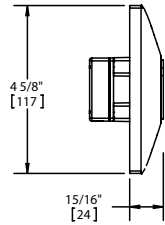

**380R**  
Recessed Mount

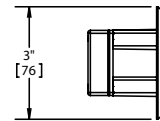
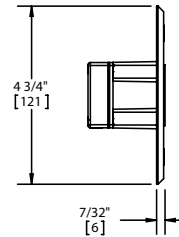

**380G**  
Floor Mount (Single Door)

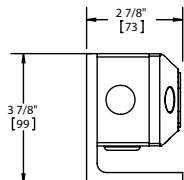
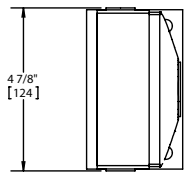

**380S**  
Surface Mount

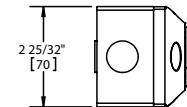
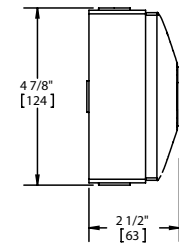

**380H**  
Floor Mount (Double Door)

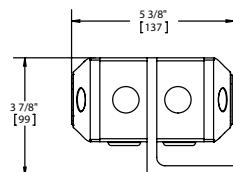
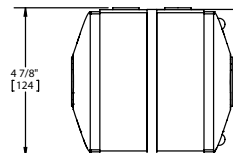

## ELECTROMAGNETIC DOOR HOLDERS - ACCESSORIES



### 381A

#### Adjustable Extension Rod

Available extension lengths 1-1/2" (38 mm), 2" (51 mm), 4" (102 mm)



### 381E

#### Extension Rod

Available extension lengths 1/2" (13 mm), 1" (25 mm), 1-1/2" (38 mm), 2" (51 mm), 3" (76 mm), 4" (102 mm)



### 381B

#### Surface Back Box

2-25/32" x 4-7/8" x 1-1/2"  
(71 mm x 124 mm x 38 mm)  
Supplied with 380G, 380H, 380S



### 381H

#### Mounting Hardware Package

Includes screws, nuts, concrete anchors, and drill bit



### 381C

#### Armature Plate

Replacement for the 381S armature plate assembly



### 381S

#### Armature Plate Assembly

Swivel design allows armature plate to move in all directions to assist with slight misalignment issues



### 381D

#### Drilling Fixture

Attach to the door for quick and accurate hole locations



### 381W

#### Extension Wrenches

Used to tighten extension rods to catch plate assembly





# Overhead Door Holders & Stops



Because Hager Companies is committed to providing our customers with a full line of door hardware, we offer both a heavy duty and standard duty option in our overhead door holders and stops product line. They are mounted at the top of the door to eliminate tripping hazards and vandalism that are typical of floor or wall mounted stops. The purpose of the overhead door holders is to absorb the abusive shock with a heavy duty spring. They evenly distribute the load and impact along the entire track of the unit. Overhead door holders and stops are compatible with a variety of door closers and are ideal for meeting the demands of high traffic areas.

Hager Companies overhead door holders and stops have been engineered and designed to meet the requirements of many door applications. The streamlined channel design along with the adjustment arm accommodates various door sizes and applications. The adjustable arms simplify the selection by combining door width ranges into only two sizes of overhead door holders and stops. This feature makes installation simple and minimally impacts a customer's inventory.



## OVERHEAD DOOR HOLDERS AND STOPS - METHODS OF INSTALLATION

### Concealed Mounted

The installation of concealed overhead door holders and stops requires that the jamb bracket be mortised flush with the bottom of the jamb. The arm and channel must be mortised into the door so the arm is flush with the top of the door. Concealing the overhead door holders and stops in the top of the door creates a more attractive architectural look.

#### Single Acting Door

A cutout made for the arm on the stop side of the single acting door.

#### Double Acting Door

Double acting doors require a cutout for the arm on both sides of the door.

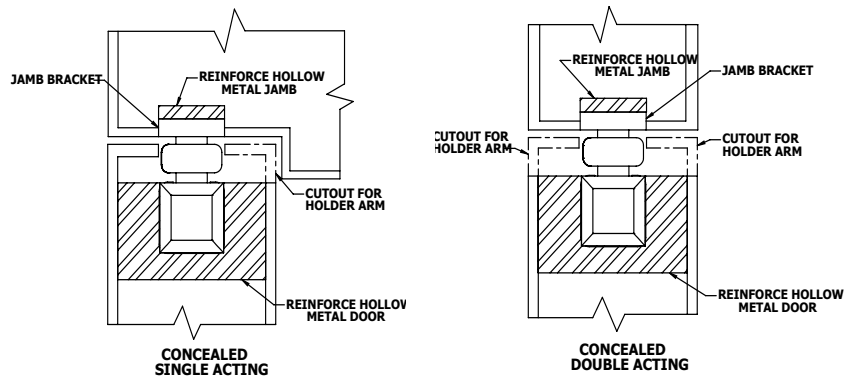

### Surface Mounted

Surface mounted overhead door holder and stop installation requires the jamb bracket be surface mounted on the stop of the frame. The channel is also surface mounted on the face of the door. Hollow metal doors and jambs must be reinforced to provide necessary strength for the holder specified.

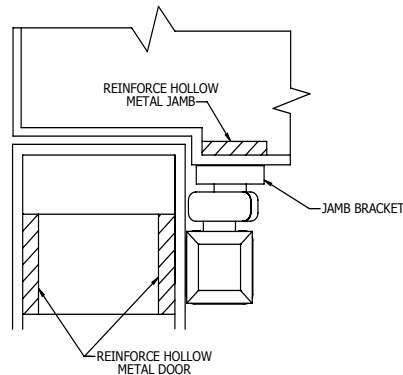

### Door and Frame Reinforcement

Hollow metal frames must be properly reinforced with 3/16" (5 mm) thick plates/channels that are at least 12" (305 mm) long. Hollow metal doors must be properly reinforced with 3/16" (5 mm) plates that are at least 2-1/2" (64 mm) wide over the length of the device. Templates and installation instructions are available online at [www.hagerco.com](http://www.hagerco.com).

### Selecting Degree of Hold Open or Stop

Overhead door holders and stops are designed to function effectively from 85° to 110°. The recommended minimum degree of hold open would be set at 95° to put the door lever, pull, and panic hardware beyond the flow of traffic.

When selecting the degree of hold open for doors opening against a wall or back to back, there is approximately 5° to 7° of spring engagement beyond the hold open or initial stop point, this is the dead stop.

For dead stop templating, the degree of opening should be set 5° to 7° less than the point of required dead stop to accommodate the full compression of the shock absorber.



## OVERHEAD DOOR HOLDERS AND STOPS - HOW TO ORDER

### Selection Steps:

1. Determine the required grade needed

Function	Description
16 - Stop Only	Shock absorbing spring stops the door 
17 - Hold Open	Select hold open with easy to adjust tension - may be turned on or off, and includes the stop function
15 - Friction	Multi-point friction hold open adjustable for resistance to door movement

2. Determine the required function
3. Determine if a surface or concealed mount is required
4. Finally select one of two sizes to fit the opening

### 7000 Series: Grade 1- Heavy Duty Overhead Holders and Stops

#### Available Functions

- Stop
- Hold Open
- Friction

#### Mounting Types

- Concealed
- Surface

#### Size Options

- Size 1 - 24" to 40"
- Size 2 - 41" to 55"



### 6000 Series: Grade 2- Standard Duty Overhead Holders and Stops

#### Available Functions

- Stop
- Hold Open
- Friction

#### Mounting Types

- Concealed
- Surface

#### Size Options

- Size 1 - 18" to 33" (Concealed Mounted) 20" to 33" (Surface Mounted)
- Size 2 - 33" to 51"



Note: It is recommended to utilize overhead door holders and stops on doors furnished with door closers, they are not intended to stop the door and should not be expected to perform the functions of a door stop.

## OVERHEAD DOOR HOLDERS AND STOPS - HOW TO ORDER

**60**

**15**

**CON**

**SZ1**

**US32D**

**SX1G**

### Component Type

- 15 - Friction
- 16 - Stop Only
- 17 - Hold Open

### Size

- SZ1 - Size 1
- SZ2 - Size 2

### Fastener Options

- SX1G - Sexbolts for 1-3/8" ( mm) door
- SX1N - Sexbolts for 1-3/4" ( mm) door
- SX2 - Sexbolts for 2" ( mm) door
- SX2D - Sexbolts for 2-1/4" ( mm) door

### Mount

- CON - Concealed
- SRF - Surface

### Product Group

- 60 - Standard Duty Overhead Door Holders and Stops
- 70 - Heavy Duty Overhead Door Holders and Stops

### Finish

- US3 - Bright Brass
- US10B - Satin Bronze
- US32D - Satin Stainless

## Functions

### 16 - Stop Only

- Concealed Mounted: ANSI CO1541
- Surface Mounted: ANSI CO2541

The stop only function provides a reliable method of door control. A shock absorbing spring stops the door. It is UL Listed for fire-rated components.

### UL Classification

The **stop-only** models are classified by Underwriters Laboratories (UL) as Miscellaneous Fire Door Accessories. This classification applies to the use on either hollow metal fire doors or wood fire doors of any rating. The accessories have been investigated to determine that when properly installed with accordance to the manufacturer's instructions, they do not adversely affect the fire-rating of the fire door or fire door frames.

### 17 - Hold Open

- Concealed Mounted: ANSI CO1511
- Surface Mounted: ANSI CO2511

The hold open function provides a selective hold open function with easy to adjust tension. It may be turned on or off and includes the stop only function. It is not for use on fire-rated openings.

### 15 - Friction

- Concealed Mounted: ANSI CO4531
- Surface Mounted: ANSI CO5531

The multi-point friction hold open function mechanism is adjustable for resistance to door movement. It is not for use on fire-rated openings.





## OVERHEAD DOOR HOLDERS AND STOPS - 6000 SERIES GRADE 2 STANDARD DUTY

<b>WARRANTY</b>	Five-year warranty
<b>FEATURES</b>	<ul style="list-style-type: none"> <li>• Standard screw pack</li> <li>• For use on exterior and interior doors</li> <li>• Ideal for office buildings and other standard duty commercial applications</li> </ul>
Certification:	<ul style="list-style-type: none"> <li>• BHMA Certified ANSI A156.8</li> <li>• UL/cUL Listed for up to 3 hours (stop only)</li> <li>• UL10C Positive Pressure Rated (stop only)</li> <li>• UL10B Neutral Pressure Rated (stop only)</li> </ul>
Materials:	<ul style="list-style-type: none"> <li>• Steel</li> <li>• Stainless steel</li> </ul>
Mounting Style:	<ul style="list-style-type: none"> <li>• Concealed</li> <li>• Surface</li> </ul>
Doors:	<ul style="list-style-type: none"> <li>• Single acting doors for concealed and surface mounted</li> <li>• Double acting doors for concealed mounted only</li> </ul>
Functions:	<ul style="list-style-type: none"> <li>• Stop Only</li> <li>• Hold Open</li> <li>• Friction</li> </ul>
Handing:	Non-handed
Openings:	Degree of opening is fully adjustable and can be adapted to changing needs between 85° to 110°



### SPECIFICATIONS

Door Thickness:	<ul style="list-style-type: none"> <li>• 1-3/4" (44 mm) thick door - Standard</li> <li>• 1- 3/8"- 2-1/4" (36-57 mm) thick door - Optional</li> </ul>
Fasteners:	Standard screw packet included for wood or metal door and frame applications
Notes:	<ul style="list-style-type: none"> <li>• Adjustable arms provide easy installation</li> <li>• Slide track design</li> <li>• Adjustable in the field</li> <li>• Heavy shock absorber spring provides 5° to 7° compression before deadstop</li> <li>• Special templating upon request</li> </ul>

<b>FINISHES</b>	<ul style="list-style-type: none"> <li>• US10B and US3 (For steel)</li> <li>• US32D (For stainless steel)</li> </ul>
-----------------	--

### SIZE SELECTION

Door Sizes	
Size	Door Width
6000 SZ1	18"- 33" (Concealed Mounted) 20"- 33" (Surface Mounted)
6000 SZ2	33"- 51"

## OVERHEAD DOOR HOLDERS AND STOPS - 6000 SERIES

### ACCESSORIES



**2-659-0101 | 2-659-0102 | 2-659-0103**  
**Surface Mounted End Cap and Spring Replacement Kit**

- Channel end caps
- Replacement spring
- 2-659-0101 is US26D, 2-659-0102 is US10B, 2-659-0103 is US3



**2-659-0104**  
**Concealed Mounted End Cap and Spring Replacement Kit**

- Channel end caps
- Replacement spring



**2-659-0105**  
**Hold Open Replacement Kit**

- Hold open assembly



**2-659-0106**  
**Friction Replacement Kit**

- Friction assembly

### SCREWPACKS



**2-659-0098 | 2-659-0099 | 2-659-0100**

**Screwpack - Standard**

- Machine screws
- Wood screws
- Sex nuts and bolts for 1-3/4" (44 mm)
- Arm sets screws
- Allen wrench
- 2-659-0098 is US26D, 2-659-0099 is US10B, 2-659-0100 is US3



**2-659-0107 | 2-659-0108 | 2-659-0109**

**SNB Screw Pack - Optional**

- Sex nuts and bolts for 1-3/8" (35 mm) doors
- Machine screws
- For use with surface mounted overhead door holders and stops
- 2-659-0107 is US26D, 2-659-0108 is US10B, 2-659-0109 is US3



**2-659-0110 | 2-659-0111 | 2-659-0112**

**SNB Screw Pack - Optional**

- Sex nuts and bolts for 2" (51 mm) doors
- Machine screws
- For use with surface mounted overhead door holders and stops
- 2-659-0110 is US26D, 2-659-0111 is US10B, 2-659-0112 is US3



**2-659-0113 | 2-659-0114 | 2-659-0115**

**SNB Screw Pack - Optional**

- Sex nuts and bolts for 2-1/4" (57 mm) doors
- Machine screws
- For use with surface mounted overhead door holders and stops
- 2-659-0113 is US26D, 2-659-0114 is US10B, 2-659-0115 is US3



## OVERHEAD DOOR HOLDERS AND STOPS - 7000 SERIES GRADE 1 HEAVY DUTY

<b>WARRANTY</b>	Five-year warranty
<b>FEATURES</b>	<ul style="list-style-type: none"> <li>• Standard screw pack</li> <li>• For use on exterior and interior doors</li> <li>• Ideal for hospitals, schools, and other high traffic environments</li> </ul>
Certification:	<ul style="list-style-type: none"> <li>• BHMA Certified ANSI A156.8</li> <li>• UL/cUL Listed for up to 3 hours (stop only)</li> <li>• UL10C Positive Pressure Rated (stop only)</li> <li>• UL10B Neutral Pressure Rated (stop only)</li> </ul>
Materials:	<ul style="list-style-type: none"> <li>• Steel</li> <li>• Stainless steel</li> </ul>
Mounting Style:	<ul style="list-style-type: none"> <li>• Concealed</li> <li>• Surface</li> </ul>
Doors:	<ul style="list-style-type: none"> <li>• Single acting doors for concealed and surface mounted</li> <li>• Double acting doors for concealed mounted only</li> </ul>
Functions:	<ul style="list-style-type: none"> <li>• Stop Only</li> <li>• Hold Open</li> <li>• Friction</li> </ul>
Handing:	Non-handed
Openings:	Degree of opening is fully adjustable and can be adapted to changing needs between 85° to 110°



### SPECIFICATIONS

Door Thickness:	<ul style="list-style-type: none"> <li>• 1-3/4" (44 mm) thick door - Standard</li> <li>• 1- 3/8"- 2-1/4" (36-57 mm) thick door - Optional</li> </ul>
Fasteners:	Standard screw packet included for wood or metal door and frame applications
Notes:	<ul style="list-style-type: none"> <li>• Adjustable arms provide easy installation</li> <li>• Slide track design</li> <li>• Adjustable in the field</li> <li>• Heavy shock absorber spring provides 5° to 7° compression before deadstop</li> <li>• Special templating upon request</li> </ul>

### FINISHES

- US10B and US3 (For steel)
- US32D (For stainless steel)

### SIZE SELECTION

Door Sizes	
Size	Door Width
7000 SZ1	24"- 40"
7000 SZ2	41"- 55"



## OVERHEAD DOOR HOLDERS AND STOPS - 7000 SERIES

### ACCESSORIES



- 2-659-0119 | 2-659-0120 | 2-659-0121**  
**Surface Mounted End Cap and Spring Replacement Kit**
- Channel end caps
  - Replacement spring
  - 2-659-0119 is US26D, 2-659-0120 is US10B, 2-659-0121 is US3



- 2-659-0122**  
**Concealed Mounted End Cap and Spring Replacement Kit**
- Channel end caps
  - Replacement spring



- 2-659-0123**  
**Hold Open Replacement Kit**
- Hold open assembly



- 2-659-0124**  
**Friction Replacement Kit**
- Friction assembly

### SCREWPACKS



- 2-659-0116 | 2-659-0117 | 2-659-0118**  
**Screwpack - Standard**
- Machine screws
  - Wood screws
  - Sex nuts and bolts for 1-3/4" (44 mm)
  - Arm set screws
  - Allen wrench
  - 2-659-0116 is US26D, 2-659-0117 is US10B, 2-659-0118 is US3



- 2-659-0125 | 2-659-0126 | 2-659-0127**  
**SNB Screw Pack - Optional**
- Sex nuts and bolts for 1-3/8" (35 mm) doors
  - Machine screws
  - For use with surface mounted overhead door holders and stops
  - 2-659-0125 is US26D, 2-659-0126 is US10B, 2-659-0127 is US3



- 2-659-0128 | 2-659-0129 | 2-659-0130**  
**SNB Screw Pack - Optional**
- Sex nuts and bolts for 2" (51 mm) doors
  - Machine screws
  - For use with surface mounted overhead door holders and stops
  - 2-659-0128 is US26D, 2-659-0129 is US10B, 2-659-0130 is US3



- 2-659-0131 | 2-659-0132 | 2-659-0133**  
**SNB Screw Pack - Optional**
- Sex nuts and bolts for 2-1/4" (57 mm) doors
  - Machine screws
  - For use with surface mounted overhead door holders and stops
  - 2-659-0132 is US10B, 2-659-0133 is US3



**One Family. One Brand. One Vision.™**

[www.hagerco.com](http://www.hagerco.com)



**One Family. One Brand. One Vision.™**

[www.hagerco.com](http://www.hagerco.com)

# Electrified Solutions



Hager Companies offers a range of electrified door hardware to help you meet customer expectations while also meeting building codes and ensuring life safety. Hager's complete electrified solutions are proven designs with versatile applications and simplified installation.

Hager's line of electric strikes fit any application. All of our strikes have compact designs, are non-handed, and can be field selectable to fail safe or fail secure configurations allowing for universal installations and simpler inventory management.

## Table of Contents

Component Selection .....	3
<b>Locking Devices .....</b>	<b>5</b>
Electric Strikes .....	6
Delayed Egress .....	9
Magnetic Locks .....	13-21
<b>Access Controls .....</b>	<b>23</b>
Key Switches .....	24, 27
Keypads .....	25-26
<b>Egress Devices .....</b>	<b>29</b>
2972/2972 IET Exit Switch.....	30
2973 Code Compliant Exit Switch .....	31
2-679-0611/12 PIR Egress Sensor .....	32
2977 Piezoelectric Exit Switch .....	33
2978 Touchless Exit Switch.....	34
4801 Non-Latching Pressure Sense Push Bar .....	35
2-679-0708 Emergency Door Release .....	36
Electric Power Transfer Devices .....	37
Door Position Sensors.....	39
Power Supply & Door Controllers .....	41
<b>Low Energy Power Operators .....</b>	<b>51</b>
Component Selection.....	53
8400 Series .....	60
8200 Series .....	67
Actuators.....	75
Accessories.....	85





## COMPONENT SELECTION

### 1 Locking Devices (Pages 5-21)

- Electric Strike
- Delayed Egress
- Electrified Lockset
- Exit Device
- Frame Actuator Lockset
- Magnetic Lock

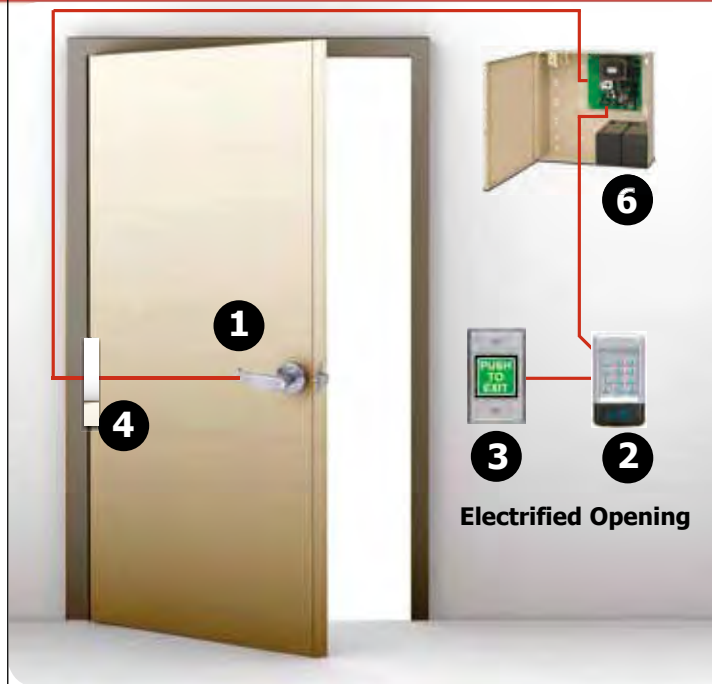

### 2 Access Controls (Pages 23-27)

- Standalone or Network
- Keyswitch
  - Digital Keypad
  - Card Reader



### 3 Egress Devices (Pages 29-36)

- Exit Switch
- PIR Egress Sensor
- Exit Sense Bar
- Emergency Door Release



### 4 Electric Power Transfer Devices (Pages 37-38)

- Required With Locksets & Exit Devices
- Electric Power Hinge
  - Power Transfer Loop
  - Concealed Power Transfer
  - Electrified Roton



### 5 Door Position Sensors (Pages 39-40)



### 6 Power Supply & Door Controllers (Pages 41-49)

- 2901**  
Power Supply  
• Designed to operate exit devices equipped with electric latch retraction (ELR)
- 2902**  
Power Supply  
• Designed to operate exit devices equipped with electric latch retraction with day/night mode feature (ELR)
- 2903**  
Power Supply  
• Provides power for Fail Safe or Fail Secure locking devices  
• 24 V output; 2 AMP capacity  
• Filtered/regulated

- 2904**  
Power Supply  
• Provides power and control for openings with an electrified locking device and automatic door operator  
• 24 V output; 2 AMP capacity  
• Filtered/regulated

- 2908**  
Power Supply  
• Modular  
• Provides power for Fail Safe or Fail Secure locking devices  
• 12/24 V output;  
• 1 AMP capacity  
• Filtered/regulated



- 2909**  
Power Supply  
• Modular  
• Provides power for Fail Safe or Fail Secure locking devices  
• 12/24 V output; 2 AMP capacity  
• Filtered/regulated



# Locking Devices



Hager offers a comprehensive product line of electronic locking devices ranging from strikes, delayed egress systems, and magnetic locks.

Electric door strikes allows for a range of functionality for any access control system. Ranging from an exterior door such as an employee entrance or an interior door such as a stairwell, Hager's electric strikes have a variety of universal features as well as factory configurations to accommodate a range of locksets, doors, frames, applications, and building codes.

Delayed egress systems are ideal for security, safety, and loss prevention applications. Many of Hager's delayed egress systems are installed in public facilities such as airports to control pedestrian traffic. Other Hager units are installed in brick and mortar retail stores to prevent theft while other installations include assisted living facilities to protect patients and childcare facilities to protect children.

Typically used on exit doors, when unauthorized egress is initiated when in the locked mode. The system delays egress through the door for 15 or 30 seconds (where approved). Meanwhile, the person exiting must wait while personnel or security respond. The door unlocks after 15 seconds has elapsed, permitting egress. A signal from the fire life safety system will release the lock for uninhibited egress in an emergency. Typical installations include airports, convention halls, wholesale stores, retail stores, long term care, drug and alcohol rehab, psychiatric care, infant nurseries, museums, art galleries, warehouses, and technological facilities.

Hager's magnetic locks are designed to be used on interior doors, perimeter exit doors, and entrances that require fail safe emergency release. Hager's magnetic locks have no moving parts and provides positive and instantaneous release, whether caused by a signal from the fire command center, remote control or access control.







## LOCKING DEVICES - 2925 ELECTRIC STRIKE

**MODELS**  
2925

4-7/8" (124 mm) faceplate for aluminum, wood, and hollow metal frames

**WARRANTY**

One-year warranty

**APPLICATION**

- Cylindrical locksets with up to 5/8" (15mm) throw latch bolts
- Access controlled ingress for fail secure or fail safe openings (field selectable)
- Economy option provides great performance and value

Latch:

1/2" (13 mm) [5/8" (16 mm) with 1/8" (3 mm) door gap]

**FEATURES**

Components:

- Quick and easy installation with low profile 1-1/4" (32 mm) backset
- All stainless steel parts with durable diecast body for corrosion resistance
- Compact low profile design with internally mounted solenoid and factory supplied mounting tabs
- Non-handed (reversible)
- Latch status output (standard)



**ELECTRICAL SPECIFICATIONS**

Input:

Current/Voltage 200/100 mA @ 12/24VDC (Field selectable)

Monitoring:

Latch Status (Std) SPDT, DRY 3A @ 30VDC

**MECHANICAL SPECIFICATIONS**

Dimensions: 1-1/4" (32 mm) W x 4-7/8" (124 mm) H x 1-1/4" (32 mm) D

**ACCESSORIES**

BUZZ

- Part no. 2-679-0028
- Plug-In Buzzer 12/24VDC
- Indicates fail secure strike is energized and unlocked

RECT

- Part no. 2-679-0029
- Converts AC to DC
- Wire leads

**FINISHES**

US32D





## LOCKING DEVICES - 2928 MULTI-APPLICATION ELECTRIC STRIKE

### MODELS

2928-SC  
2928-RC  
2928-6R  
2928-7R

- 4-7/8" (124 mm) x 1-1/4" (32 mm) square corner faceplate
- 4-7/8" (124 mm) x 1-1/4" (32 mm) radius corner faceplate
- 6-7/8" (175 mm) x 1-1/4" (32 mm) radius corner faceplate
- 7-15/16" (202 mm) x 1-7/16" (36 mm) radius corner faceplate

### WARRANTY

One-year warranty

### APPLICATION

- Cylindrical and mortise locksets with up to 3/4" (19 mm) throw latch bolts with 1/8" door gap
- Access controlled ingress for fail secure or fail safe openings (field selectable)
- Field selectable voltage - 12/24V, AC/DC
- Ideal for medium traffic openings

Latch:

- 1/2" (13 mm)
- 5/8" (16 mm) with 1/8" (3 mm) door gap
- 3/4" (19 mm)

### FEATURES

Components:

- Quick and easy installation with low profile 1-3/16" backset
- Latch position status (standard)
- Keeper locked/unlocked status (standard)
- Keeper open/closed and status (optional)
- Compact low profile design with internally mounted solenoid and factory supplied mounting tabs
- Non-handed (reversible)
- 1/4" (6 mm) horizontal alignment adjustment
- All stainless steel parts with durable diecast body for corrosion resistance
- Fewer moving parts for maximum life
- Stainless steel is standard with square corner faceplates
- Aluminum standard with radius corner faceplate
- Plug in tail connectors

Certification:

- ANSI A156.31, Grade 2

### OPTIONS

KOC:

Keeper/open closed status

### ELECTRICAL SPECIFICATIONS

Inputs:

Current/Voltage

- 200/100 mA @ 12/24VDC
- 140/70 mA @ 12/24VAC

Monitoring:

Latch Status (Std.)

SPDT, Dry 3 A @ 30VDC

Keeper Locked

Status (Std.)

SPDT, Dry 3 A @ 30VDC

Keeper Open

Status (Opt.)

SPDT, Dry 3 A @ 30VDC

### MECHANICAL SPECIFICATIONS

Dimensions:

1-1/4" (32 mm) W x 4-7/8" (124 mm) H x 1-3/16" (30 mm) D

### ACCESSORIES

BUZZ

- Part no. 2-679-0028
- Plug-In Buzzer 12/24VDC
- Indicates fail secure strike is energized and unlocked

### FINISHES

- US32D (2928-SC only)
- ALM (standard with 2928-RC, 2928-6R, 2928-7R)





## LOCKING DEVICES - 2930 UNIVERSAL APPLICATION ELECTRIC STRIKE

### MODELS

2930-CYL  
2930-MOR  
2930-MDB

- For use with Grade 1 cylindrical locksets
- For use with Hager mortise locks
- For use with Hager mortise locks with deadbolt

### WARRANTY

One-year warranty

### APPLICATION

- Heavy duty electric strike
- Designed for installation in hollow metal frames with Grade 1 cylindrical and mortise locksets with up to 3/4" (19 mm) throw latch bolts and 1" deadbolts (25 mm)
- Designed for new construction and retrofit applications
- Field selectable fail safe or fail secure (default setting) with no disassembly
- For use on fire-rated and non fire-rated doors
- *Fail safe is not permitted on fire-rated doors*

### FEATURES

Components:

- Retrofits existing ANSI 4-7/8" (124 mm) strike prep - no centerline relocation
- Fail secure standard; field reversible to fail safe (no disassembly)
- Up to 3/4" (919 mm) latch bolt and 1" (25 mm) deadbolt
- Non-handed (reversible)
- 1/8" (3 mm) horizontal alignment adjustment
- Factory tested 2,500 lbs.
- Exceeded 1,000,000 cycles
- UL tested 1,500 lbs.
- 70 ft-lb dynamic strength
- Internally mounted solenoid, no heat in keeper
- Tamper resistant
- All stainless steel parts with durable diecast body for corrosion resistance
- Plug in tail connectors

Certification:

- ANSI A156.31 compliant, Grade 1
- UL - 1034 Burglary Resistant (interior use application)
- BP - 10254
- IL10C.3H Fire-Rated, 4' x 8' door
- NFPA 252
- CAN 4-5104 (Fail Secure Only)



### ELECTRICAL & MECHANICAL SPECIFICATIONS

Input:

Current/Voltage 600/300 mA @ 12/24V DC

Monitoring:

LBM (Opt.) SPDT, Dry 5 A @ 30V DC  
DSM (Opt.) SPDT, Dry 5 A @ 30V DC  
DBM (Opt.) SPDT, Dry 5 A @ 30V DC (*Handed*)

### ACCESSORIES

BUZZ

- Part no. 2-679-0028
- Plug-In Buzzer 12/24 VDC
- Indicates fail secure strike is energized and unlocked

RECT

- Part no. 2-679-0029
- Converts AC to DC
- Wire leads

### FINISHES

US4, US10, US10B, US26,  
US26D, US32D (standard)

### OPTIONS

LBM

- Latch Bolt Monitor
- Door closed/latched or open/unlatched status
- Access control anti-tailgate/timer reset signal

DSM

- Door Secure Monitor (DSM)
- Door secure and unlocked monitoring
- Mantraps, interlocks, airlocks

DBM

- Deadbolt Monitoring (DBM - Handed)
- Signals deadbolt projected or retracted
- Occupied signal rooms/bathrooms
- Manual lockout of access control by deadbolt

### NOTES

Fire-Rated:

Not approved for fail safe operation on fire-rated doors

Handing:

- CYL, MOR with monitoring are non-handed
- DBM with monitoring is handed





## LOCKING DEVICES - DELAYED EGRESS

### MODELS

4501 DE/4601 DE  
2-679-0630

Delayed Egress Exit Device  
Delayed Egress Wall Mount Controller  
*- Must be ordered separately*



### WARRANTY

One-year warranty

### APPLICATION

- Control pedestrian traffic
  - Airport & Public Facility Security and Safety
  - Loss Prevention
- Wandering Patient and Infant Protection (Compatible with Hugs® and other patient tracking systems)
- Intended for single or double doors that require panic hardware

### FEATURES

Components:

- Alternating 85 db tone and voice message (75 db @ 3 feet)
  - Voice and digital display provides informative annunciation for people without prior knowledge, including the blind and hearing impaired
  - Voice provides warning or safety message, countdown and time of door release
  - Digital countdown display indicated if the door was opened after lock release
- 15 or 30 second egress delay
- 1 or 2 second nuisance delay
- Built-in function keypad provides alarm and lock reset, 1 to 30 second bypass, sustained bypass, and additional key switch
- Control inputs include 1 to 30 second request-to-exit and access bypass with anti-tailgate and alarm reset
- Field selectable trigger modes from exit device (N/O or N/C)
- Field selectable automatic or manual power up after emergency release or power loss

Built-In

Annunciation:

- Armed mode
- Nuisance mode
- Irreversible egress mode
- Release mode
- Digital countdown display
- Field selectable voice notification or tone
- Field selectable male voice with security message or female voice with safety message

Monitoring

Outputs:

- Armed status
- Egress initiation status
- Released status

Power Up Modes:

Field selectable automatic or manual power up after emergency release or power loss

Code Compliance:

- Use of manual power up complies with California Building Code (OSHPD) requirements
- International Fire Code (IFC) 1008.1.8.6 Delayed Egress Locks
- International Building Code (IBC) 1008.1.8.6 Delayed Egress Locks
- NFPA 101, Life Safety Code 7.2.1.6.1 Delayed Egress Lock
- NFPA 1 Uniform Fire Code
- California Building Code (CBC) 1008.1.8.6 Special Egress Control Devices

### ELECTRICAL SPECIFICATIONS

#### Inputs:

Voltage Input:

- Single 430mA @ 24VDC
- Tandem 680mA @ 24CVDC

Reset Input:

N/O, Dry contact

REX Input:

N/C, Dry contact

Trigger:

N/C, Dry contact





## LOCKING DEVICES - DELAYED EGRESS

Monitoring Outputs: Alarm output - 1 amp @ 30VDC SPDT, Dry  
Locked output - 1 amp @30VDC SPDT, Dry

**MONITORING**  
Alarm Output: SPDT Dry, 1A @ 30 VDC, Dry  
Locked Output: SPDT Dry, 1A @ 30 VDC, Dry

### MECHANICAL SPECIFICATIONS

Controller Dimensions: 6-1/2" (165 mm) W x 4-1/2" (114 mm) H x 1-1/2" (38 mm) D

Controller Mounting: Recessed or Surface Mount

### ACCESSORIES

2-679-0641 3-gang interior surface mount box

2-679-0642 Shroud for surface mount box

### FINISHES

Controller:

- Aluminum anodized (standard)
- Dark Bronze anodized
- Black anodized

### NOTES

- SVR exits must include rod covers
- Door position switch (DPS) is recommended for higher security. Contact Hager Tech Support for additional information.





## LOCKING DEVICES - 2958 INTEGRATED DELAYED EGRESS LOCK

### MODELS

2958

Single magnetic lock with 1650 lbs. holding force (748 kg)

2985T

Tandem magnetic lock with 1650 lbs. holding force (748 kg)

### WARRANTY

One-year warranty

### APPLICATION

- Control pedestrian traffic
  - *Airport & Public Facility Security and Safety*
  - *Loss Prevention*
- Wandering Patient and Infant Protection (Compatible with Hugs® and other patient tracking systems)
- Intended for single doors with latching or non-latching hardware
- Tandem model intended for use with pairs of doors with latching or non-latching hardware where activating the lock unlocks both doors



### FEATURES

Components:

- Field selectable voice and tone or tone only (75 db @ 3 feet)
  - *Voice and digital display provides informative annunciation for people without prior knowledge, including the blind and hearing impaired*
  - *Voice provides warning or safety message, countdown and time of door release*
  - *Digital countdown display indicated if the door was opened after lock release*
- Choice of 15 second exit and 1 second nuisance delay or field selectable 15 or 30 second exit delay and 1 or 2 second nuisance delay
- Field selectable security or safety message
- Field selectable activation
- Field selectable automatic or manual relock upon power up after emergency release
- Integrated 3 position key switch
  - *Provides lock and alarm reset Manual power up sustained bypass, time bypass, adjustment for 1, 15, 20 or 30 seconds*
- Field selectable door prop alarm
  - *Alarm sounds when the door has been left open after selected bypass time has elapsed*
- Anti-tailgate feature
- Alternating 85db tone and voice message

Control Inputs:

- Remote access control and REX input, field adjustable for 1, 15, 20, or 30 seconds
- Remote reset input
- Manual power-up input
- Emergency release input
- Anti-tailgate input

Monitoring

Outputs:

- Door secure and unlocked output
- Delayed egress activation alarm output

Certifications:

ANSI certified, ANSI Grade 1

Code Compliance:

- International Building Code (IBC) 1008.1.8.6 Delayed Egress Locks
- International Fire Code (IFC) 1008.1.8.6 Delayed Egress Locks
- NFPA 101, Life Safety Code 7.2.1.6.1 Delayed Egress Lock
- California Building Code (CBC) 1008.1.8.6 Special Egress Control Devices
- BOCA, National Building Code 1017.4.1.2 Special Locking Arrangements
- Chicago Building Code 10 (13-160-269) Electromagnetic Locking Devices
  - *Certificate of approval available*



## LOCKING DEVICES - 2958 INTEGRATED DELAYED EGRESS LOCK

### OPTIONS

DPS	Door Position Switch
MBS	Magnetic Bond Sensor
ATS	Anti-Tamper Switch

### RESET & CONTROL

PS	Built-in reset push switch, available with NFPA (NA) only
NS	Less key switch or push switch

Input Voltage: Auto Sensing 12 to 24VDC

Current:  
2958 830mA @ 12VDC  
450mA @ 24VDC

2958T 1500mA @ 12VDC  
850mA @ 24VDC

Reset Input: N/O, Dry contact  
REX Input: N/O, Dry contact  
Trigger Input: N/O, Dry contact  
Fire Alarm Input: N/O, Dry contact

### MONITORING

Alarm Output: SPDT Dry, 1A @ 30VDC

Lock Secure  
Unlocked: SPDT Dry, 1A @ 30VDC

Door Position  
Switch: SPDT Dry, 250mA @ 30VDC

Magnetic Bond  
Sensor: SPDT Dry, 250 mA @ 30VDC

Anti-Tamper  
Switch: SPDT Dry, 1A @ 30VDC

### MECHANICAL SPECIFICATIONS

Dimensions:  
2958 11" (279 mm) W x 2-3/4" (70 mm) H x 2-5/8" (67 mm) D  
2958T Master 11" (279 mm) W x 2-3/4" (70 mm) H x 2-5/8" (67 mm) D  
2958T Slave 11" (279 mm) W x 2-3/4" (70 mm) H x 2-5/8" (67 mm) D  
Armature 7-3/8" (187 mm) W x 2-3/8" (60 mm) H x 9/16" (14 mm) D

### FINISHES

ALM Aluminum anodized (standard)  
DBZ Dark bronze anodized  
BLK Black anodized

### NOTES

Local Approval: All installations must be approved by the Authority Having Jurisdiction (AHJ)





## LOCKING DEVICES - 2941 MAGNETIC LOCK

**WARRANTY** | One-year warranty

**MODELS**  
2941 | 600 lbs. holding force (272 kg)

**APPLICATION** | For interior door traffic control where physical attack is not a concern

**FEATURES**

Components:

- Designed for system integrators, distributors, installers, and building owners presently using low cost import or private label brand access control hardware
- Interlocking quick mount assembly
- Provides superior, less obtrusive appearance compared to stainless steel epoxy sealed magnetic locks
- Full monitoring is standard
- Door status, lock status and bi-color LED included
- Adjustable mounting bracket with choice of self-drilling and tapping mounting screws or machine screws
- Wire access chamber with terminal block
- Printed circuit board with voltage and current spike protection
- Instant release anti-residual magnetism circuit

Certification: | ANSI/BHMA A156.23 Grade 1, Compliant



**ELECTRICAL SPECIFICATIONS**

**Input:**

Current/Voltage: | 500mA/250mA @ 12/24VDC (field selectable)

**MONITORING**

Lock Status: | SPDT, Dry 2mA @ 30VDC

Door Status: | SPDT, Dry 500mA @ 30VDC

**ACCESSORIES**

- 2-679-0101 | Top Jamb Kit
- 2-679-0103 | Glass Armature Mounting Kit
- 2-679-0106 | Angle Bracket (cut to fit 2941)
- 2-679-0107 | Stop Filler Plate (field cut for 2941)
- 2-679-0108 | Stop Filler Plate (field cut for 2941)

**MECHANICAL SPECIFICATIONS**

Lock Dimensions: | 9-7/8" (251 mm) W x 2" (51 mm) H x 1" (25 mm) D

Armature  
Dimensions: | 7-5/16" (186 mm) W x 1-1/2" (38 mm) H x 1/2" (13 mm) D

**FINISHES** | Aluminum anodized





## LOCKING DEVICES - 2942 MAGNETIC LOCK

### MODELS

2942 | 1200 lbs. holding force (545 kg)

### WARRANTY

One-year warranty

### APPLICATION

For perimeter and interior door security and access control

### FEATURES

Components:

- Designed for system integrators, distributors, installers, and building owners presently using low cost import or private label brand access control hardware
- Interlocking quick mount assembly
- Provides superior, less obtrusive appearance compared to stainless steel epoxy sealed magnetic locks
- Full monitoring is standard
- Door status, lock status and bi-color LED included
- Adjustable mounting bracket with choice of self-drilling and tapping mounting screws or machine screws
- Wire access chamber with terminal block
- Printed circuit board with voltage and current spike protection
- Instant release anti-residual magnetism circuit

Certification:

ANSI/BHMA A156.23 Grade 1, Compliant



### ELECTRICAL SPECIFICATIONS

#### Input:

Current/Voltage: 500mA/250mA @ 12/24VDC (field selectable)

### MONITORING

Lock Status: SPDT, Dry 2mA @ 30VDC

Door Status: SPDT, Dry 500mA @ 30VDC

### ACCESSORIES

2-679-0100 | Top Jamb Kit  
 2-679-0102 | Glass Armature Mounting Kit  
 2-679-0106 | Angle Bracket  
 2-679-0107 | Stop Filler Plate  
 2-679-0108 | Stop Filler Plate

### MECHANICAL SPECIFICATIONS

Lock Dimensions: 10-1/2" (267 mm) W x 2-7/8" (73 mm) H x 1-5/8" (41 mm) D

Armature

Dimensions: 7-5/16" (186 mm) W x 2-3/8" (60 mm) H x 1/2" (13 mm) D

### FINISHES

Aluminum anodized





## LOCKING DEVICES - 2941 AND 2942 ACCESSORIES

### TOP JAMB MOUNTING KITS FOR INSWING DOORS



#### **2-679-0100**

Top jamb kit for use with 2942

#### **2-679-0101**

Top jamb kit for use with 2941

### GLASS DOOR ARMATURE MOUNTING KITS



#### **2-679-0102**

Glass door kit for use with 2942

#### **2-679-0103**

Glass door kit for use with 2941

### ANGLE BRACKETS



Used for the extension of a narrow frame header mounting surface, the bracket provides additional surface area for proper lock mounting.

#### **2-679-0106**

Angle bracket for use with 2942

cut for use with 2941

10-1/2" (l) x 1-1/2" (h) x 3/4" (d)

[266 (l) x 12 (h) x 19 (d) mm]



### TOP FILLER PLATES

Used where the frame stop does not provide enough mounting surface area for proper lock mounting.

#### **2-679-0107**

Stop filler plate for use with 2942

Cut for use with 2941

1/2" (h) x 10-1/2" (l) x 3/4" (d)

[12 (h) x 266 (l) x 19 (d) mm]

#### **2-679-0108**

Stop filler plate for use with 2942

Cut for use with 2941

3/4" (h) x 10-1/2" (l) x 3/4" (d)

[19 (h) x 266 (l) x 19 (d) mm]



## LOCKING DEVICES - 2950 MAGNETIC LOCK

### MODELS

2951	Single magnetic lock with 1650 lbs. holding force (748 kg)
2952	Double magnetic lock with 1650 lbs. holding force (748 kg)
2953	Single magnetic lock with 1200 lbs. holding force (545 kg)
2954	Double magnetic lock with 1200 lbs. holding force (545 kg)

### WARRANTY

Lifetime warranty

### APPLICATION

For perimeter and interior door security and access control

### FEATURES

Components:

- Modular design
- Modular upgrade kits
- Field upgradeable without removal
- Uniform design and installation
- Identical housing, template, and accessories
- Quick mount assembly
- Compatible with any access control system
- Secure wiring and mounting screws with interlocking mounting plate

Certification:

ANSI/BHMA A156.23 Grade 1 Compliant

### OPTIONS

Time	Built-in field adjustments 0-30 seconds re-lock delay
DPS	Door Position Switch indicates door open and door closed
ATS	Anti Tamper Switch indicates access cover removal
MBS	Magnetic Board Sensor indicates locked and unlocked, low holding power, tampering and obstruction between armature and magnetic core



### ELECTRICAL SPECIFICATIONS

#### Input:

Current/Voltage:

2951	Auto Sensing 670mA/350mA @ 12/24 VDC
2952	Auto Sensing 1.34A /700mA @ 12/24VDC
2953	Auto Sensing 250mA/125mA @ 12/24VDC
2954	Auto Sensing 500mA/250mA @ 12/24VDC

### MONITORING

Time	SPDT, Dry 20mA @ 30VDC
DPS	SPDT, Dry 20mA @ 30VDC
ATS	SPDT, Dry 20mA @ 30VDC
MBS	SPDT, Dry 20mA @ 30VDC

### ACCESSORIES

2-679-0109	Timer Input Module
2-679-0110	Door Position Sensor
2-679-0111	Magnetic Bond Sensor
2-679-0112	Anti-Tamper Switch

### MECHANICAL SPECIFICATIONS

2951 & 2953	Dimensions: 11" (279 mm) W x 2-3/4" (70 mm) H x 1-9/16" (40 mm) D
2952 & 2954	
2952 & 2954	Dimensions: 22" (559 mm) W x 2-3/4" (70 mm) H x 1-9/16" (40 mm) D

### FINISHES

ALM	Aluminum anodized (standard)
DBZ	Dark bronze anodized

### MOUNTING KITS

- Top Jamb Kit
- Glass Door Kit
- Universal Header Bracket
- Spacer Bracket
- Armature Mounting Plate with and without Sensor Door Coordinator Lock Mounting Kit
- Filler Plates
- Angle Brackets
- See Mounting Kits Reference File for complete list of all mounting kits and part number





## LOCKING DEVICES - 2950 SERIES ACCESSORIES

### MODULAR KITS

#### 2-679-0109

Timer Input Module  
Built-in field adjustable 0-30 seconds re-lock delay

#### 2-679-0110

Door Position Sensor  
Indicates door open and door closed

#### 2-679-0111

Magnetic Bond Sensor  
Indicates locked and unlocked, low holding power, tampering and obstruction between armature and magnetic core

#### 2-679-0112

Anti-Tamper Switch  
Indicates access cover removal.

### TOP JAMB MOUNTING KITS FOR INSWING DOORS



#### 2-679-0120

Top jamb kit for use with 2951 and 2953  
ALM

#### 2-679-0121

Top jamb kit for use with 2951 and 2953  
DBZ

#### 2-679-0130

Top jamb kit for use with 2952 and 2954  
ALM

#### 2-679-0131

Top jamb kit for use with 2952 and 2954  
DBZ

### GLASS DOOR ARMATURE MOUNTING KITS



#### 2-679-0160

Glass door kit for use with 2951 and 2953  
ALM

#### 2-679-0161

Glass door kit for use with 2951 and 2953  
DBZ

Note: For 2952 and 2954, order two (2) glass door armature mounting kits.

### UNIVERSAL HEADER BRACKET



Used in lieu of angle brackets, a universal header bracket provides a faster mounting solution, saving time and labor costs. Reduce potential for missized and misaligned mounting

holes, broken taps, removal of broken taps. Combined with interlocking easy mount assembly, save up to a half day's labor with the installation of 12 locks.

- Solid 1" (25 mm) bar provides higher security and superior aesthetics
- Machined wire chase provides concealed and secure wiring
- Multiple pre-drilled and tapped mounting holes to accommodate the use of several different locks on either 4" (102 mm) or 4-1/2" (114 mm) aluminum frames

#### 2-679-0180

For use with 2951 and 2953  
1 x 1 x 11 in (25 x 25 x 279 mm)  
ALM

#### 2-679-0181

For use with 2951 and 2953  
1 x 1 x 11 in (25 x 25 x 279 mm)  
DBZ

#### 2-679-0190

For use with 2952 and 2954  
1 x 1 x 22 in (25 x 25 x 559 mm)  
ALM

#### 2-679-0191

For use with 2952 and 2954  
1 x 1 x 22 in (25 x 25 x 559 mm)  
DBZ



## LOCKING DEVICES - 2950 SERIES ACCESSORIES

### SPACER BRACKETS



Aluminum frames with blade stop - lowers magnetic lock below blade stop. Concrete filled hollow metal frames - provides multiple points for concealed wire entry.

- Pre-drilled and tapped specifically for 2951 and 2952 magnetic locks
- Machined wire chase provides multiple points for concealed wire entry from concrete filled frames
- ALM (aluminum) finish

#### 2-679-0200

Bracket for 2951 and 2953  
1/2 x 1-1/2 x 11 in (13 x 38 x 279 mm)

#### 2-679-0201

Bracket for 2952 and 2954  
1/2 x 1-1/2 x 22 in (13 x 38 x 559 mm)

### ARMATURE MOUNTING PLATE

Armature mounting plates provide a solution for mounting magnetic locks to the top rail of aluminum, glass, wood, and hollow metal doors that do not permit the use of thru bolts.



#### 2-679-0204

Armature mounting plate

#### 2-679-0205

Armature mounting plate with sensor

Note: For 2952 and 2954, order two (2) armature mounting plates.

### FILLER PLATES

Filler plates are for extension of the stop to provide a proper mounting surface on the underside of the header. Available in Aluminum (ALM) or Dark Bronze (DBZ) finish. Contact Hager Tech Support for part numbers for additional finishes (including BRZ, BLK, US3, US4, US26, and US26D).



#### For 11" (279 mm) Single Magnetic Lock Models (2951/2953)

#### 2-679-0281

ALM  
1/8 x 1-1/4 in (3 x 32 mm)

#### 2-679-0283

DBZ  
1/8 x 1-1/4 in (3 x 32 mm)

#### 2-679-0291

ALM  
1/4 x 1-1/4 in (6 x 32 mm)

#### 2-679-0293

DBZ  
1/4 x 1-1/4 in (6 x 32 mm)

#### 2-679-0311

ALM  
1/2 x 1-1/4 in (13 x 32 mm)

#### 2-679-0313

DBZ  
1/2 x 1-1/4 in (13 x 32 mm)

#### 2-679-0321

ALM  
5/8 x 1-1/4 in (16 x 32 mm)

#### 2-679-0323

DBZ  
5/8 x 1-1/4 in (16 x 32 mm)

#### For 22" (559 mm) Double Magnetic Lock Models (2952/2954)

#### 2-679-0381

ALM  
1/8 x 1-1/4 in (3 x 32 mm)

#### 2-679-0383

DBZ  
1/8 x 1-1/4 in (3 x 32 mm)

#### 2-679-0391

ALM  
1/4 x 1-1/4 in (6 x 32 mm)

#### 2-679-0393

DBZ  
1/4 x 1-1/4 in (6 x 32 mm)

#### 2-679-0411

ALM  
1/2 x 1-1/4 in (13 x 32 mm)

#### 2-679-0413

DBZ  
1/2 x 1-1/4 in (13 x 32 mm)

#### 2-679-0421

ALM  
5/8 x 1-1/4 in (16 x 32 mm)

#### 2-679-0423

DBZ  
5/8 x 1-1/4 in (16 x 32 mm)





## LOCKING DEVICES - 2950 SERIES ACCESSORIES



### ANGLE BRACKETS

Angle brackets are used as extensions on shallow door frames to provide adequate mounting surface. Available in Aluminum (ALM) or Dark Bronze

(DBZ) finish. Contact Hager Tech Support for part numbers for additional finishes (including BRZ, BLK, US3, US4, US26, and US26D).

#### For 11" (279 mm) Single Magnetic Lock Models (2951/2953)

##### **2-679-0491**

ALM

1-1/2 x 1-1/2 in (38 x 38 mm)

##### **2-679-0493**

DBZ

1-1/2 x 1-1/2 in (38 x 38 mm)

##### **2-679-0501**

ALM

2 x 1-1/2 in (51 x 38 mm)

##### **2-679-0503**

DBZ

2 x 1-1/2 in (51 x 38 mm)

#### For 22" ( mm) Double Magnetic Lock Models (2952/2954)

##### **2-679-0571**

ALM

1-1/2 x 1-1/2 in (38 x 38 mm)

##### **2-679-0573**

DBZ

1-1/2 x 1-1/2 in (38 x 38 mm)

##### **2-679-0581**

ALM

2 x 1-1/2 in (51 x 38 mm)

##### **2-679-0583**

DBZ

2 x 1-1/2 in (51 x 38 mm)



### DOOR COORDINATOR LOCK MOUNTING KITS

##### **2-679-0210**

Door coordinator lock mounting kit for use with 2951 and 2953

ALM

##### **2-679-0220**

Door coordinator lock mounting kit for use with 2952 and 2954

DBZ



## LOCKING DEVICES - 2961 SERIES MAGNETIC SHEAR LOCK

### MODELS

2961

Single magnetic shear lock with 2000 lbs. holding force (907 kg)

### WARRANTY

One-year warranty

### APPLICATION

For commercial grade hollow metal and wood doors and frames and Herculite doors with top rails

### FEATURES

- Concealed, high security, Fail Safe locking mechanism
- Incorporates floating armature assembly and special alloy steel locking tabs on both lock and armature assemblies
- May be adjusted both vertically and laterally to compensate for wide door gaps and warped or misaligned doors

### Components:

- 2,000 lbs (907 kg) holding force without current inrush or high operating temperature
- 8" x 1-1/2" (203 mm x 38 mm) lock
- Integrated electronics
- 1-5/8" (41 mm) depth for 1-3/4" - 2" (44 mm - 51 mm) frames
- Armature supplied with lock (specify type required - ITC, FTC, or HTC)
- Door static sensor ensures door is at rest and aligned, before the magnet is permitted to energize (eliminates the potential for lock misalignment)
- Lateral adjustment of shear tabs to compensate for warped or misaligned doors, permitting accurate locking
- Vertical adjustment of both the armature and the adjustable delay relock sensor compensates for wide door gaps
- Unique floating action for easy armature lift when the magnet is energized and provides ability to overcome wide door gaps
- Alloy shear tabs ensure continued high holding force
- No profiling of the soft armature steel that may be prone to wear and reduced holding force
- Advanced electronic circuitry that incorporates door static, positioning and timed relock sensor and automatic voltage sensing for 12/24 VDC input
- Noise dampeners reduce the noise associated with locking and unlocking



### OPTIONS

- MBS**
- Bond sensor indicates proper armature contact or reduced holding power due to improper armature contact or tampering
  - SPDT 0.25 amp
- DPS**
- Door position switch indicates door open or closed
  - SPDT 0.25 amp maximum
- HTR**
- Herculite top rail armature adjustment bracket for leading edge adjustments

### ELECTRICAL SPECIFICATIONS

#### Input:

Voltage: Auto Sensing 650/350 mA @ 12/24 VDC

### MONITORING

DPS SPDT, Dry 20mA @ 30VDC  
MBS SPDT, Dry 20mA @ 30VDC

### ACCESSORIES

2-679-0600 Wood door reinforcement box (sold separately)

### ARMATURES

ITC Armature Standard mounting armature kit for aluminum and hollow metal doors with 7/8" to 1-1/8" deep top channels, wood doors, and factory prepared hollow metal flush edge doors

FTC Armature Mounting kit for field prepared horizontal mounting in hollow metal doors with flush edge

HTC Armature Mounting kit for 1-15/16" deep Herculite channels

### MECHANICAL SPECIFICATIONS

Lock Dimensions: 8" (203 mm) W x 1-1/2" (38 mm) H x 1-5/8" (41 mm) D

Armature Dimensions: 8" (203 mm) W x 1-1/2" (38 mm) H x 7/8" (48 mm) D

### FINISHES

ALM Aluminum anodized (standard)





## LOCKING DEVICES - 2965 MAGNETIC SHEAR LOCK

### MODELS

2965 Single magnetic shear lock with 2700 lbs. holding force (1225 kg)

### WARRANTY

One-year warranty

### APPLICATION

For commercial grade hollow metal and wood doors and frames and Herculite doors with top rails

### FEATURES

- Concealed, high security, Fail Safe locking mechanism
- Incorporates floating armature assembly and special alloy steel locking tabs on both lock and armature assemblies
- May be adjusted both vertically and laterally to compensate for wide door gaps and warped or misaligned doors



### Components:

- 2,700 lbs (1225 kg) holding force without current inrush or high operating temperature
- 10-7/16" x 1-1/2" (265 mm x 38 mm) lock
- Integrated electronics
- 1-5/8" (41 mm) depth for 1-3/4" - 2" (44 mm - 51 mm) frames
- Armature supplied with lock (specify type required - ITC, FTC, or HTC)
- Door static sensor ensures door is at rest and aligned, before the magnet is permitted to energize (eliminates the potential for lock misalignment)
- Lateral adjustment of shear tabs to compensate for warped or misaligned doors, permitting accurate locking
- Vertical adjustment of both the armature and the adjustable delay relock sensor compensates for wide door gaps
- Unique floating action for easy armature lift when the magnet is energized and provides ability to overcome wide door gaps
- Alloy shear tabs ensure continued high holding force
- No profiling of the soft armature steel that may be prone to wear and reduced holding force
- Advanced electronic circuitry that incorporates door static, positioning and timed relock sensor and automatic voltage sensing for 12/24 VDC input
- Noise dampeners reduce the noise associated with locking and unlocking

### OPTIONS

#### MBS

- Bond sensor indicates proper armature contact or reduced holding power due to improper armature contact or tampering
- SPDT 0.25 amp

#### DPS

- Door position switch indicates door open or closed
- SPDT 0.25 amp maximum

#### HTR

Herculite top rail armature adjustment bracket for leading edge adjustments

### ELECTRICAL SPECIFICATIONS

#### Input:

Voltage: Auto Sensing 800/400 mA @ 12/24 VDC

### MONITORING

#### MBS

SPDT, Dry 250mA @ 30VDC

#### DPS

SPDT, Dry 250mA @ 30VDC

### MECHANICAL SPECIFICATIONS

Lock Dimensions: 10-7/16" (265 mm) W x 1-1/2" (38 mm) H x 1-5/8" (41 mm) D

#### Armature

Dimensions: 11" (279 mm) W x 1-1/2" (38 mm) H x 7/8" (48 mm) D

### FINISHES

#### ALM

Aluminum anodized (standard)

### ACCESSORIES

#### 2-679-0601

Wood door reinforcement box (sold separately)

### ARMATURES

#### ITC Armature

Standard mounting armature kit for aluminum and hollow metal doors with 7/8" to 1-1/8" deep top channels, wood doors, and factory prepared hollow metal flush edge doors

#### FTC Armature

Mounting kit for field prepared horizontal mounting in hollow metal doors with flush edge

#### HTC Armature

Mounting kit for 1-15/16" deep Herculite channels







# Access Controls



As the demand for access controls continue to grow, Hager Companies offers proven, reliable, and innovative solutions. While access control keypad devices are fairly definitive, customer requirements and building codes can vary. Hager Companies keypad product line offers solutions for these differing demands and requirements.

Key switches are ideal for a range of electrified openings such as an auditorium or gate operation that you might find near a hotel pool. With many different types of applications, key switches are an economical and viable devices in many installations.

Hager's line of heavy duty keypads has an array of ideal installations. The 2915 is perfect for secure areas such as a records archive room or server room. The 2916 and 2916P are ideal for outdoor installations such as college dormitories, apartment buildings, remote buildings, and office buildings.

Hager Companies provides proven and reliable products for the ever growing access control market. For more information, please visit the Hager Companies website at [www.hagerco.com](http://www.hagerco.com)





## ACCESS CONTROLS - 29KS KEY SWITCH

### MODELS

29KS | Key switch

### WARRANTY

One-year warranty

### APPLICATION

- Access control
- Automatic gate operation
- Alarm shunt
- Alarm reset
- Machine operation

### FEATURES

- Provides an economical method of providing authorized control for a variety of applications
- Choice of several contact configurations ensures compatibility with virtually any system
- Compatible with U.S. standard 1.125" and 1.25" mortise key cylinders and interchangeable core cylinders (not included)
- Compatibility with a new or existing facility mechanical key system is maintained
- Standard switch assemblies are single gang box mounted

### Components:

- Single gang, wall mounted, recessed key cylinder
- Tamper resistant, recessed cylinder
- Tamper resistant spanner screws
- Heavy duty all steel assembly
- 20 gauge stainless steel faceplate
- Large actuator for positive and consistent activation
- Compatible with 1.125" or 1.25" mortise cylinder (non included)

### Functions:

ASD | Alternate Action (on/off) SPDT  
 MSD | Momentary SPDT  
 ADD | Alternate Action (on/off) DPDT  
 MDD | Momentary DPDT

### ELECTRICAL SPECIFICATIONS

Voltage: | • 6 amp @ 30 VDC  
 | • 7", 22 gauge wire leads

### OPTIONS

LEDG | One (1) green LED  
 LEDR | One (1) red LED  
 2LED | One (1) green and one (1) red LED

### CYLINDER

3902 | 1-1/8" recommended (order separately)  
 3978 | Cam required (order separately)

### MECHANICAL SPECIFICATIONS

Dimensions: | 2-7/8" (73 mm) W x 4-1/2" (114 mm) H x 20 Gauge (0.912 mm)

### FINISHES

US32D

### NOTES

- Single switch assembly requires cloverleaf cam
- Dual switch assembly requires standard cam





## ACCESS CONTROLS - 2915 HEAVY DUTY KEYPAD

### MODELS

2915 | Heavy Duty Keypad

### WARRANTY

One-year warranty

### APPLICATION

- Single gang indoor keypad
- Designed to control access of a single entry point for facilities with up to 500 users
- Each user assigned a personal identification number (PIN)

### FEATURES

#### Components:

- Blue backlit, moisture-resistant keypad
- 3/32" (2 mm) thick stainless steel faceplate
- 1/4" (6 mm) wall extrusion depth
- 500 users, 4-6 digit PIN codes
- 4 outputs, 2 relay and 2 solid status outputs timed or latching (on/off)
- Assign entry PINs to relays 1 and/or 2
- LED status: access, lockout
- Tactile audible key press, select volume
- Timed anti-passback
- Keypad tamper lockout
- Code activated timed entry PIN disable
- Request-to-exit/Enter input, egress keypad input
- Choice of door sense/relay inhibit input functions (forced entry, door ajar, inhibit relay 1 or 2, auto relock when door closes)
- Choice of 2 solid status output functions (alarm shunt, forced entry, door ajar, tamper lockout, keypad active)



### ELECTRICAL SPECIFICATIONS

#### Inputs:

Voltage: | Auto Sensing 12 to 24 VAC/DC

Current: | 30mA typical, 150 mA maximum

Operating Temperature: | -20° to 130°F (-30° to 54°C)

Operating Humidity: | 5 - 95% (non-condensing)

#### OUTPUTS

Relay 1 | Form "C", 5 amps @ 28VDC

Relay 2 | • Form "C", 2 amps @ 28VDC  
• Switch to common outputs 3 & 4, 100 mA @ 30VDC

### MECHANICAL SPECIFICATIONS

Dimensions: | 3" (76 mm) W x 4-3/4" (121 mm) H x 1-1/2" (38 mm) D

FINISHES | US3, US4, US10B, US26, US32D



## ACCESS CONTROLS

### MODELS

2916 Heavy Duty Keypad  
2916P Heavy Duty Keypad

### WARRANTY

One-year warranty

### APPLICATION

- Surface mount indoor/outdoor keypad
- Designed to control access of a single entry point for facilities with up to 500 users
- Each user assigned a personal identification number (PIN)

### FEATURES

#### Components:

- Heavy cast vandal resistant housing
- Heavy cast metal blue backlit keys
- 500 users, 4-6 digit PIN codes
- 4 outputs, 2 relay and 2 solid status outputs timed or latching (on/off)
- Assign entry PINs to relays 1 and/or 2
- LED status: access, lockout
- Tactile audible key press, select volume
- Timed anti-passback
- Keypad tamper lockout
- Code activated timed entry PIN disable
- Request-to-exit/Enter input, egress keypad input
- Choice of door sense/relay inhibit input functions (forced entry, door ajar, inhibit relay 1 or 2, auto relock when door closes)



### ELECTRICAL SPECIFICATIONS

#### Inputs:

Voltage: Auto Sensing 12 to 24VAC/DC

Current: 30mA typical, 150mA maximum

Operating Temperature: -20° to 130°F (-30° to 54°C)

Operating Humidity: 5 - 95% (non-condensing)

#### OUTPUTS

Relay 1 Form "C", 5 amps @ 28VDC  
Relay 2 Form "C", 2 amps @ 28VDC  
Switch to common outputs 3 & 4, 100mA @ 30VDC

### MECHANICAL SPECIFICATIONS

Dimensions: 3" (76 mm) W x 5-3/4" (146 mm) H x 1-7/16" (37 mm) D

### ACCESSORIES

2-679-0669 Protective Shroud

### FINISHES

US32D





## ACCESS CONTROLS - 2-679-0708 UNDER DESK PUSH SWITCH

### MODELS

2-679-0708 | Under Desk Switch

### WARRANTY

| One-year warranty

### APPLICATION

| Enables the remote control of doors equipped with electric locks and access controls

### FEATURES

Components: | Mounts to the underside of a desk for remote door control

### ELECTRICAL SPECIFICATIONS

| Momentary push switch

### MECHANICAL SPECIFICATIONS

Dimensions: | 1" (25 mm) W x 2-1/4" (57 mm) H x 2-1/2" (63 mm) D





# Egress Devices



Just as important as access controls are egress controls. With fail secure openings, egress controls send a signal to unlock the locking device. With low energy automatic operators, knowing acts are needed to send signals to the power operator. These are all essential functions to an electrified opening. Hager Companies provides a wide range of egress controls that will satisfy your customers while being easy to install.







## EGRESS DEVICES - 2972 EXIT SWITCH

### MODELS

2972-M	Momentary SPDT Exit Switch
2972-T	Integrated electric timer (adjustable 1-60 seconds) exit switch

### WARRANTY

One-year warranty

### APPLICATION

- 2" (50 mm) illuminated switch button for easy activation
- High impact resistant material stands up to abuse
- "Push to Exit" sign complies with NFPA requirements
- Blue illuminate button designed for access and egress applications for the disabled

### OPTIONS

LEDG	One (1) green LED
LEDR	One (1) red LED
2LED	One (1) green and one (1) red LED
BLU	Disabled access button

### ELECTRICAL SPECIFICATIONS

2972M	SPDT, 5A @ 30 VDC
2972T	SPDT, 2A @ 12/24VDC
Wire Leads	6" (152 mm) - 20 gauge

### MECHANICAL SPECIFICATIONS

1 Gang

Dimensions: 2-7/8" (73 mm) W x 4-1/2" (114 mm) H

### FINISHES

US32D





## EGRESS DEVICES - 2973 CODE COMPLIANT EXIT SWITCH

### MODELS

2973 | Code Compliant Exit Switch with integrated timer (fixed 30 seconds)

### WARRANTY

One-year warranty

### APPLICATION

- Code compliant manual releasing devices and sensors
- Switch and sensor used together comply with manual releasing device and sensor device requirements for access controlled egress doors

### Certification:

- 2006 IBC 1008.1.3.4
- 2012 IBC 1008.1.9.8
- NFPA 7.2.1.6.2
- IFC 1008.1.3.4
- California Fire Code

### OPTIONS

LEDG | One (1) green LED  
 LEDR | One (1) red LED  
 2LED | One (1) green and one (1) red LED

### ELECTRICAL SPECIFICATIONS

Output: | SPDT, 5A @ 30 VDC  
 Wire Leads | 6" (152 mm) - 20 gauge

### MECHANICAL SPECIFICATIONS

Dimensions: | 1 Gang  
 2-7/8" (73 mm) W x 4-1/2" (114 mm) H

### FINISHES

US32D





## EGRESS DEVICES - PIR EGRESS SENSOR

### MODELS

2-679-0611

White PIR egress sensor

2-679-0612

Black PIR egress sensor

### WARRANTY

One-year warranty

### APPLICATION

- Access control system unit
- Unlocks doors automatically when persons approaching door are detected
- Complies with national fire and building code requirements for access controlled egress doors
- Code compliant Fail Safe mode releases locks when power to PIR sensor is interrupted

Certification:

UL Listed 294

### ELECTRICAL SPECIFICATIONS

Input: 12 or 24 VAC/DC @ 26 mA max

Output: 2 SPDT dry, 2 amp @ 30VDC

Operating Temperature: -20° to 120°F (-30° to 49°C)

### MECHANICAL SPECIFICATIONS

Dimensions: 1-1/2" (38 mm) W x 6-1/4" (159 mm) H x 1-1/2 (38 mm) D





## EGRESS DEVICES - 2977 PIEZOELECTRIC EXIT SWITCH

### MODELS

2977 | Stainless Steel Piezoelectric Request-to-Exit Switch

### WARRANTY

One-year warranty

### APPLICATION

- Designed for indoor, outdoor, commercial, and industrial egress applications
- Ideal for harsh or high traffic conditions

### FEATURES

#### Components:

- Vandal and weather resistant
  - 3/32" (2 mm) stainless steel vandal resistant faceplate
- No moving parts
- Selectable bi-color illumination status (Relay OFF - red or green) (Relay ON - red or green)
- Adjustable timer output, 1-30 seconds
- Superior performance in virtually any environment
- Can be used to control an automatic door, electromechanical lock, strike, or magnetic lock
- May be tied into the remote bypass (request-to-exit) input of an access control system
- Can be used to shunt an alarm system to allow egress from a secure area



### ELECTRICAL SPECIFICATIONS

Input:	12/24 AC/DC
Current:	Idle - 30 mA Active - 150 mA
Output:	SPDT dry contact, 3 amp @ 30 VDC
Operating Temperature:	-40° to 160°F (-40° to 71°C)
Relay:	<ul style="list-style-type: none"> <li>• 100,000 cycles @ 3 A 30 VDC life expectancy</li> <li>• 200,000 cycles @ 1.5 A 30 VDC life expectancy</li> </ul>

### MECHANICAL SPECIFICATIONS

Button Switch:	1 billion cycle life expectancy
Dimensions:	3" (76 mm) W x 4-3/4" (121 mm) H

### FINISHES

US32D



## EGRESS DEVICES - 2978 TOUCHLESS EXIT SWITCH

### MODELS

2978 Touchless Exit Switch

### WARRANTY

One-year warranty

### APPLICATION

- Designed to control electric locks/strikes, magnetic locks, or automatic door operators
- No touch wave-to-exit switch
- Active with wave of the hand
- For sanitary entry/exit applications

### FEATURES

- Components:
- Bi-color status illumination
  - Quick connect screwless terminal block for easy installation
  - No moving parts
  - Uses infrared sensor technology

### ELECTRICAL SPECIFICATIONS

- Current:
- 30 mA standby; 70 mA Active @ 12 VDC
  - 15 mA standby; 35 mA Active @ 24 VDC

Output: DPDT, 3 amp dry contact

Activation Time: 1 second or as long as sensor is triggered

LED Color: Standby - red; Active - green

Range: 4" (10 cm)

### MECHANICAL SPECIFICATIONS

Dimensions: 2-3/4" (70 mm) W x 4-1/2" (114 mm) H

### FINISHES

US32D





## EGRESS DEVICES - 4801 NON-LATCHING PRESSURE SENSE PUSH BAR

### MODELS

4801

The Sure Exit is a non-latching, heavy duty, request-to-exit push bar that will activate the 2958 & 2958T when slight pressure is applied to the bar.



### WARRANTY

One-year warranty

### FEATURES

Components:

- Magnetic lock release
- Access control request-to-exit
- Delayed egress trigger
- Alarm shunt
- CCTV or alarm activation
- Tri-Failsafe
  - a third redundant micro switch is automatically activated to release the door if both sensors or electronics fail
- No moving parts, quick, and quiet operation
- Human touch not required
- Sensor calibration not required
- Field installed green sign with 1" letters
- Heavy duty construction
- Narrow, low profile
- Two outputs
  - two dry contacts for lock release, request-to-exit, alarm shunt, alarm activation, CCTV activation
- Armored power loop
  - 18" flex stainless conduit

### ELECTRICAL SPECIFICATIONS

Voltage Input:	12/24 VDC $\pm$ 10% - no field adjustment
Current Input:	20 mA @ rest, 115 mA active
Output:	Two, SPDT Dry, 3 Amp @ 28 VDC
Operating Temperature:	0° to 150° F (-18° to 66° C)

### MECHANICAL SPECIFICATIONS

Activation Force:	<ul style="list-style-type: none"> <li>• 5 lbs. (2.2 kg)</li> <li>• Field adjustable up to 15 lbs. (6.8 kg)</li> </ul>
Dimensions:	2-3/8" (60 mm) W x 36" (914 mm) H x 1-7/8" (48 mm) D

### OPTIONS

- 42" (1,067 mm) wide doors
- 48" (1,219 mm) wide doors

### FINISHES

ALM	Aluminum anodized
BLK	Black anodized

### NOTES

Length: Bars may be field cut



## EGRESS DEVICES - 2-679-0650 EMERGENCY DOOR RELEASE

### MODELS

2-679-0650

Break glass emergency door release 3V-28 VDC, 18 mA with siren (blue)

### WARRANTY

One-year warranty

### APPLICATION

- Breakable glass emergency door release with siren
- Ideal for immediate unlocking of doors that are equipped with fail safe electric locks and may influence approval of an electronic lock system
- Built-in alarm may be used as a local door annunciator

### FEATURES

Components:

- Remote monitoring
- CCTV activation or alarm activation
- Single gang box mounted
- Two replacement glass plates included

### ELECTRICAL SPECIFICATIONS

Output: DPDT dry contact, 10 amp @ 28VDC

### MECHANICAL SPECIFICATIONS

Dimensions: 5-1/2" (140 mm) W x 3-1/2" (90 mm) H x 1-3/8" (35 mm) D



# Electric Power Transfer Devices



Electrified cylindrical locks, mortise locks, and exit devices all require power provided to them. The most effective way to do this is to run power through the middle of the door. With Hager, you can select the hinge type that you need and that your customer wants and know that all of those products can be electrified. Stay with the proven name in hinges – Hager. Since 1849, Hager has been manufacturing hinges in the U.S. and as we continue to build on our rich history, we will continue to bring our customers reliability, value, and peace of mind. Whether you need electrified conventional hinges, electrified geared Roton hinges, concealed power transfers or a transfer loop, knowing that you chose Hager as your preferred hinge brand will prove to be a wise decision.







## ELECTRIC POWER TRANSFER DEVICES - HEAVY DUTY



### **2-679-0620** **Concealed Mortise Mount Power Transfer Loop**

- Frame mortised steel dust box with flexible steel loop and chrome finish
- Recommended for use with hollow metal frames
- UL Listed
- 11-1/2 (h) x 1 (w) x 3/4 in (d)  
(292 (h) x 25 (w) x 19 (d) mm)

- Provides a concealed and secure means of transferring electric lock and exit device power and signal wires from the frame to the door
- Completely concealed when the door is closed
- Ideal for heavy traffic and applications requiring higher security to inhibit tampering and abuse

#### **MODELS**

##### 2 conductor

Two (2) 18 ga. wires, 5 amp @ 12/24 V AC/DC

##### **2-679-0621**

Aluminum powder coat (US28 equivalent)

##### **2-679-0622**

Dark brown powder coat (US10B equivalent)

##### 10 conductor

Ten (10) 24 ga. wires, 1 amp @ 12/24 V AC/DC

##### **2-679-0623**

Aluminum powder coat (US28 equivalent)

##### **2-679-0624**

Dark brown powder coat (US10B equivalent)

#### **FEATURES**

- Power control, input for electric locks and exit devices, locked, latched, mantrap, forced entry, open status signal wiring
- Mortise door and frame installation
- PTM is completely concealed when the door is closed
- All metal design with stainless steel tubular wire transfer and heavy cast housing with steel back boxes provide weather and tamper resistance when door is open or closed
- Fasteners for wood, steel, and aluminum doors and frames included
- UL Listed Miscellaneous Fire Door Accessories
- UL 10C Listed for up to 3-hours on fire-rated doors and frames
- Classified according to Uniform Building Code (UBC) Standard 7-2, Fire Test of Door Assemblies (1997)



#### **COMPATIBLE OPENINGS**

- 1-3/4" (44 mm) thick doors
- 0-180° opening swing with up to 3/4" (19 mm) offset pivots
- 0-180° opening swing with up to 5" wide butt hinges
- 0-130° opening swing with up to 5-1/2" (140 mm) wide butt hinges
- 0-130° opening swing with up to 6" (152 mm) wide butt hinges
- Not compatible with center hung doors, swing clear hinges, pocket pivots, butt hinges larger than 6" (152 mm), and 1-1/2" (38 mm) offset pivots

#### **DIMENSIONS**

9" (h) x 1-1/4" (w) x 1-5/8" (d)  
229 mm (h) x 32 mm (w) x 41 mm (d)



# Door Position Sensors



Monitoring the position of the door is crucial security. Hager Companies offers a mortise style door position sensor for new installations. We also offer a drill-in style to make retrofitting an opening quick and easy.

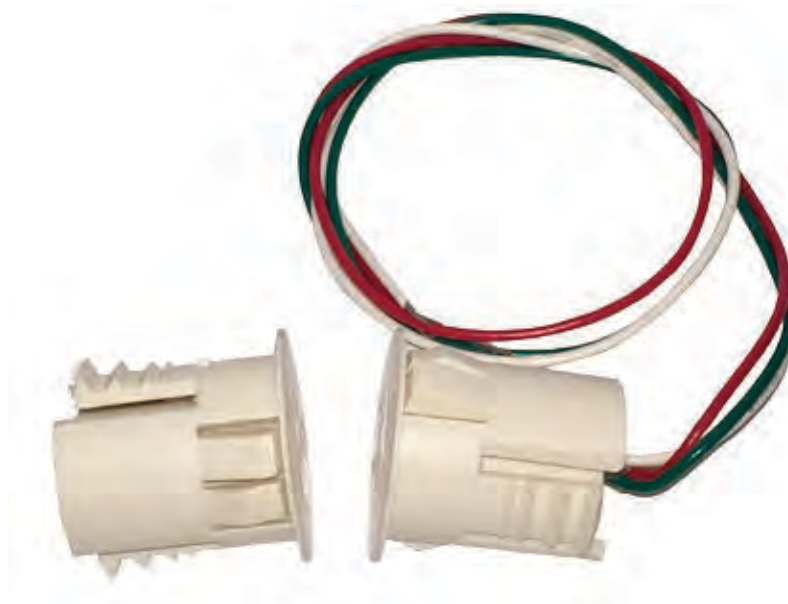



## DOOR POSITION SENSORS

### MODELS

2-679-0625 | Concealed Magnetic Contact Switch

### WARRANTY

One-year warranty

### APPLICATION

Installed in the mortise of a hollow metal or aluminum frame and wood, hollow metal or aluminum door

### ELECTRICAL SPECIFICATIONS

Contact: | SPDT, 50mA @ 30 VDC

### MECHANICAL SPECIFICATIONS

Gap: | 0.125" (3 mm)

Faceplate: | • 4.875" (h) x 1.25" (w) x 0.125" (d)  
• 123.83 mm (h) x 31.75 mm (w) x 3.18 mm (d)



### MODELS

2-679-0626 | Magnetic Switch

### WARRANTY

One-year warranty

### APPLICATION

- Ideal for door status monitoring
- Easily installed in hollow metal and aluminum doors and frames

### ELECTRICAL SPECIFICATIONS

Contact: | SPDT, 50mA @ 30 VDC

### MECHANICAL SPECIFICATIONS

Gap: | 0.5" (12.7 mm)



# Power Supply & Door Controllers



The functionality of power supplies differ based on the electrified components and their intended use. In order to have an optimized and properly operational electrified opening, the power supply should fit the opening, not the other way around. Hager offers different power supply solutions for different types of openings.

The 2901 and 2902 are specifically designed to operate electric latch retraction exit devices.

The 2903 is designed to optimize the functionality of Fail Safe or Fail Secure locking devices that interface with the building's alarm controls, card readers, keypads, and other access control systems.

The 2904 is designed to optimize openings that include a locking device and automatic door operator.

The 2908 and 2909 are modular designs that provide functionality for any type of opening whether it is an electric latch retraction exit device, locking devices that interface with other access controls, door operators with sequencing locking devices, or combination of all of those or just something completely different.





## POWER SUPPLY & DOOR CONTROLLERS - 2909

### MODELS

2909 | 2A Modular Access Control Power Supply

### WARRANTY

One-year warranty

### APPLICATION

- Modular design allows customization of each power supply
- Regulated modular access control power supply
- Equipped with a high performance transformer and highly reliable electronic components
- Filtering and output voltage regulation provide protection and ensure the longevity of all system components

### FEATURES

Components:

- Output filtering stabilizes the DC output voltage and eliminates AC line noise
- Regulator maintains output voltage at 12 or 24 VDC regardless of load changes and battery charging
- Fire alarm input that provides simultaneous release of all Fail Safe/Fail Secure locks and door holders in case of an emergency
  - *Provides simultaneous release of all Fail Safe/Fail Secure locks and door holder in case of emergency*
- Circuit breaker protected AC input voltage - secondary output is PTC protected
- LED status indicators separate PTC protected charging output
- Optional dual 12 VDC or 24 VDC outputs



### ELECTRICAL SPECIFICATIONS

Input: • 800mA @ 115 VAC, 50/60Hz  
• 230 VAC optional

Output: • 12/24 VDC, 2A  
- *field selectable*  
• Class 2

Battery Charger: 13.5/27 VDC, 500 mA

### LED INDICATORS

Amber: AC and DC voltages are OK  
Green: No DC output  
Red: No AC input, powered by batteries

### MECHANICAL SPECIFICATIONS

Dimensions: • 4" (102 mm) W x 12" (305 mm) H x 12" (305 mm) D  
• 12 gauge steel

### NOTES

ELR • Not suitable for use with solenoid actuated Electric Latch Retraction (ELR) exit devices  
• Suitable for motor driven ELR exit devices





## POWER SUPPLY & DOOR CONTROLLERS - 2908

### MODELS

2908 | 1A Modular Access Control Power Supply

### WARRANTY

One-year warranty

### APPLICATION

- Modular design allows customization of each power supply
- Regulated modular access control power supply
- Equipped with a high performance transformer and highly reliable electronic components
- Filtering and output voltage regulation provide protection and ensure the longevity of all system components

### FEATURES

Components:

- Fire alarm input
  - Provides simultaneous release of all Fail Safe/Fail Secure locks and door holder in case of emergency
- Circuit breaker protected AC input voltage - secondary output and battery backup status
- Separate PTC protected charging output
- Optional dual 12 VDC or 24 VDC outputs
- Standard California compliant manual release



### ELECTRICAL SPECIFICATIONS

Input:
 

- 600mA @ 115 VAC, 50/60Hz
- 230 VAC optional

Output:
 

- 12/24 VDC, 1A
- Field selectable

Battery Charger: 13.5/27 VDC, 500 mA

### MECHANICAL SPECIFICATIONS

Dimensions:
 

- 4" (102 mm) W x 12" (305 mm) H x 12" (305 mm) D
- 12 gauge steel

### ACCESSORIES

2-679-0661

- 5 Amp hour battery backup
  - Uses a separate, protected output for charging - includes a low battery disconnect that protects the battery from potential damage during extended battery powered situations
  - When multiple batteries are used, install in parallel to increase current, or install in series to increase voltage. For more information, please contact Hager Tech Support.

2-679-0662

- 12 VDC Output Regulator Module
  - Enables dual 12V and 24V output

2-679-0664

- Universal Relay Module
  - Multiple field selectable operational modes for up to two door stations

### NOTES

ELR

- Not suitable for use with solenoid actuated Electric Latch Retraction (ELR) exit devices
- Suitable for motor driven ELR exit devices



## POWER SUPPLY & DOOR CONTROLLERS - 2908 & 2909 MODULES

### MODELS

2-679-0661 | 5 Amp hour battery backup

### WARRANTY

One-year warranty

### APPLICATION

Allows continued operation of your access controlled opening upon power failure

---

### MODELS

2-679-0662 | 12 VDC Output Regulator Module

### WARRANTY

One-year warranty

### APPLICATION

Allows for dual voltage output applications where openings require a 12VDC and 24VDC

---

### ELECTRICAL SPECIFICATIONS

Input: | 24 VDC

Output: | 500A @12 VDC

---

### MODELS

2-679-0664 | Universal Relay Module

### WARRANTY

One-year warranty

### APPLICATION

- Conventional Relay (CR)
  - Dual Conventional Relay (2x CR)
  - Time Delay Relay (TD) (1-60sec)
  - Dual Time Delay Relay (2x TD) (1-60sec)
  - Latching Relay (LR) - Separate Latch and Release Inputs
  - Dual Latching Relay (2x LR) Pulse on Pulse off
  - Time Delay x Latching Relay
  - Interlock A (Air Lock)
  - Interlock B (2 Modules Required)
- 

### ELECTRICAL SPECIFICATIONS

Input: | 120/175mA @ 12/24 VDC

Output: | 2 each field selectable wet or dry

Wet | 120/175mA@ 12/24 VDC

Dry | SPDT, Dry 10A @ 30 VDC

---

### MODELS

2-679-0703 | Electric Latch Retraction Sequencer Module

### WARRANTY

One-year warranty

### APPLICATION

Allow for sequencing of electrified hardware on openings with Auto Operator

---

### ELECTRICAL SPECIFICATIONS

Input: | 12 VDC or 24 VDC (+/- 10%) - 140 mA max

Exit & Operator  
Contacts: | N/C or N/O, field selectable 10 AMP @ 30 VDC (Resistive)

Access Control  
Inputs: | N/O Dry Contact

---





## POWER SUPPLY & DOOR CONTROLLERS - 2908 & 2909 MODULES

### MODELS

2-679-0704 | Access Control Module

### WARRANTY

One-year warranty

### APPLICATION

Installer friendly relay board used to control and monitor openings

### ELECTRICAL SPECIFICATIONS

Input:

- 75mA@ 12/24 VDC
- 3 - N/C Normally Closed Inputs
- 3 - N/O Normally Open Inputs

Output:

- 5 Amp (Resistive) fail safe lock output
  - 5 Amp (Resistive) fail secure lock output
  - Lock status: SPDT (Form C) dry contact
- 

### MODELS

2-679-0705 | 16 Amp Power Boost Module

### WARRANTY

One-year warranty

### APPLICATION

Used for electric latch retraction exit devices that require 24 VDC with 16 amp inrush

### ELECTRICAL SPECIFICATIONS

Input:

- 85mA @ 24 VDC
- Dry N/O trigger input ONLY

Output:

- 16A surge
- 1A continuous

Note:

**Works with Hager 2909 Power Supply**

---

### MODELS

2-679-0706 | Power Supply Monitor Module

### WARRANTY

One-year warranty

### APPLICATION

Provides outputs to monitor Hager 2909 power supply status and A/C power and DC output/battery status

### ELECTRICAL SPECIFICATIONS

- 2 SPDT 1 amp repay outputs
- On/off status

Note:

**Works with Hager 2909 Power Supply ONLY**





## POWER SUPPLY & DOOR CONTROLLERS - 2904

### MODELS

2904 | MLR & Auto Operator Access Control Power Supply

### WARRANTY

One-year warranty

### APPLICATION

Provides power and control for openings with an electrified locking device and automatic door operator

### FEATURES

Components:

- Filtered and regulated 24 VDC output
- 2A load capacity
- Class 2 rated outputs
- Overload, over voltage, and short circuit protection
- Automatically accepts 120 or 240 VAC input
- Built in fail safe or fail secure locking device controller
- Built in dry contact output for automatic door operator input
- Auxiliary 24 VDC constant voltage output (1 amp max output)
- Separate input for activation switch on entry and exit side of opening
- Fire alarm input
- Adjustable time delay



### ELECTRICAL SPECIFICATIONS

Input: 900mA @ 120 VAC, 60Hz  
600mA @ 240 VAC, 50/60Hz

Output: 24 VDC, 2A

### MECHANICAL SPECIFICATIONS

Dimensions: 4-1/4" (108 mm) W x 10-1/4" (260 mm) H x 10-1/4" (260 mm) D

### NOTES

- ELR
- Not suitable for use with solenoid actuated Electric Latch Retraction (ELR) exit devices
  - Suitable for motor driven ELR exit devices





## POWER SUPPLY & DOOR CONTROLLERS - 2903

### MODELS

2903 | Access Control & Locking Device Power Supply

### WARRANTY

One-year warranty

### APPLICATION

For use with Fail Safe and Fail Secure locking devices that interface with building alarm controls, card readers, keypads, and other door controls

### FEATURES

Components:

- Filtered and regulated 24 VDC output
- 2A load capacity
- Class 2 rated outputs
- Overload, over voltage, and short circuit protection
- Automatically accepts 120 or 240 VAC input
- Built in fail safe or fail secure locking device controller
- Surge suppression on fail safe and fail secure outputs
- Interface relay isolates locking device outputs from control switch
- Adjustable time delay



### ELECTRICAL SPECIFICATIONS

Input: 

- 900mA @ 120 VAC, 60Hz
- 600mA @ 240 VAC, 50/60Hz

Output: 24 VDC, 2A

### MECHANICAL SPECIFICATIONS

Dimensions: 4-1/4" (108 mm) W x 10-1/4" (260 mm) H x 10-1/4" (260 mm) D

### NOTES

ELR 

- Not suitable for use with solenoid actuated Electric Latch Retraction (ELR) exit devices
- Suitable for motor driven ELR exit devices



## POWER SUPPLY & DOOR CONTROLLERS - 2902

### MODELS

2902 | Electric Latch Retraction Controller & Power Supply with Day/Night Mode

### WARRANTY

One-year warranty

### APPLICATION

For use with Hager's 4500 Series Electric Latch Retraction (ELR) exit devices in a day/night mode of operation

### FEATURES

Components:

- Auxiliary 12 and 24 VDC outputs
- Built-in dry contact output for automatic door operator input
- Adjustable time delay
- Fire alarm input
- Operator day/night mode of operation

### ELECTRICAL SPECIFICATIONS

Input: | 750mA @ 120 VAC; 60Hz

Output: |

- 250mA @ 12.6-16.5 VDC; Unregulated & Unfiltered
- 250mA @ 26.7-28.0 VDC; Unregulated & Unfiltered

### MECHANICAL SPECIFICATIONS

Dimensions: | 4-1/4" (108 mm) W x 10-1/4" (260 mm) H x 10-1/4" (260 mm) D





## POWER SUPPLY & DOOR CONTROLLERS - 2901

### MODELS

2901 | Electric Latch Retraction Controller & Power Supply

### WARRANTY

One-Year Warranty

### APPLICATION

For use with Hager's 4500 Series Electric Latch Retraction (ELR) exit devices

### FEATURES

Components:

- Auxiliary 12 and 24 VDC outputs
- Built-in— dry contact output for automatic door operator input
- Adjustable time delay
- Fire alarm input
- Single or dual system latch retraction



### ELECTRICAL SPECIFICATIONS

Input: | 750mA @ 120 VAC; 60Hz

Output: |

- 250mA @ 12.6-16.5 VDC; Unregulated & Unfiltered
- 250mA @ 26.7-28.0 VDC; Unregulated & Unfiltered

### MECHANICAL SPECIFICATIONS

Dimensions: | 4-1/4" (108 mm) W x 10-1/4" (260 mm) H x 10-1/4" (260 mm) D



# 8400 Series Low Energy Power Operator



As more and more buildings are becoming ADA compliant, more options need to be made available. Hager's low energy operators allow you to do just that without a long list of part numbers to keep track of. Instead, Hager's low energy operators are customizable so that you can meet your customer's requirements and expectations each and every time.

The 8400 Series is Hager's premium low energy operator that reduces installation costs by being designed in a unique way that allows for one person installation and each unit includes an on-board programmer so that the installer programs one unit and then uses a flash drive to set up the other units in the same way with the same functionality.

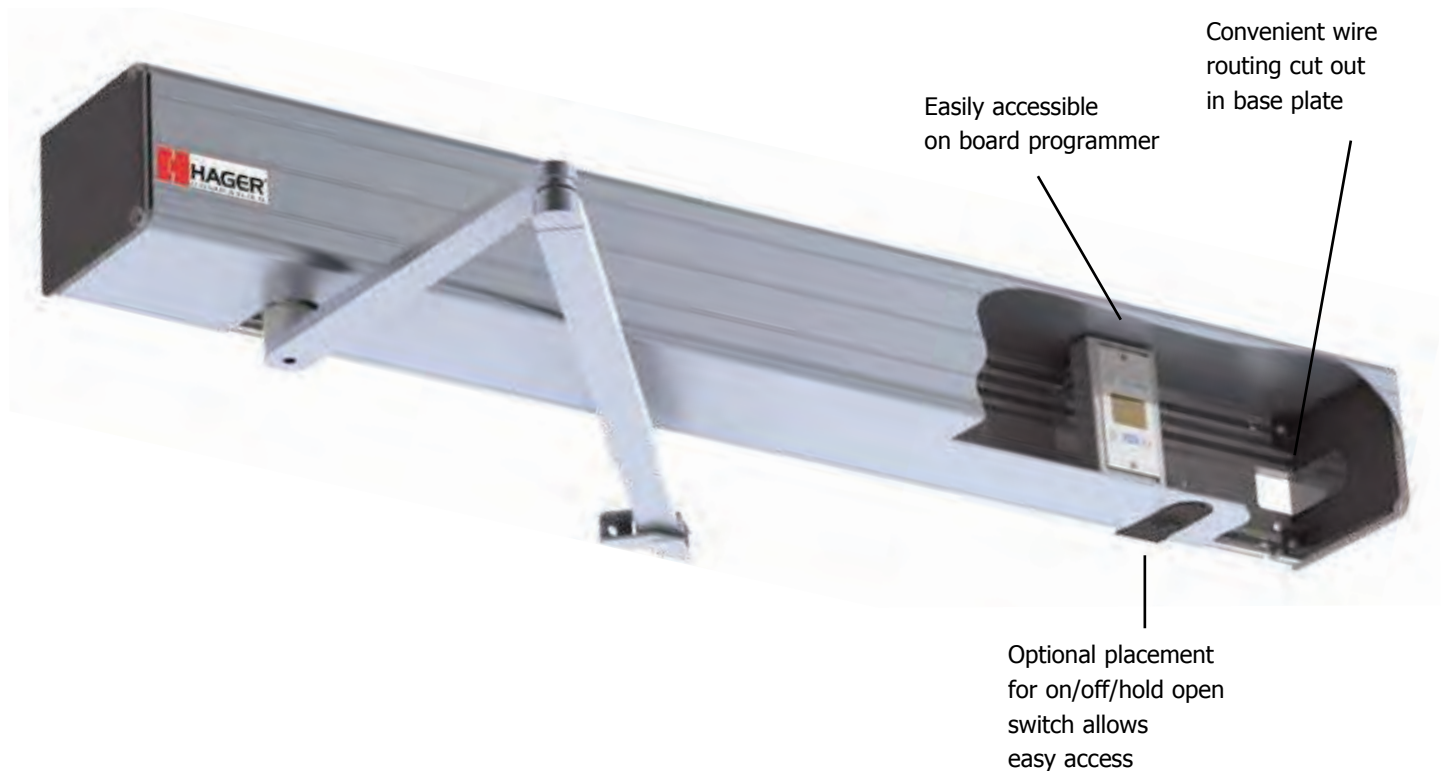





## LOW ENERGY POWER OPERATOR COMPONENT SELECTION

### 1 Low Energy Power Operators

#### 8400 Series - (Pages 54-61)

Premium Low Energy Power Operator

- Single Operator
- Paired Operator
- Double Egress Operator
- Single Operator Paired with Mechanical Closer

#### 8200 Series - (Pages 67-69)

Economy Low Energy Power Operator

- Single Operator
- Double Egress Operator



### 2 Parts & Accessories

#### 8400 Series - (Pages 63-65)

- Track Arm
- Standard Arm
- Standard Arm - Double Egress
- Track Arm - Double Egress
- Replacement Spindle

#### 8200 Series (Pages 71-73)

- Standard Arm
- Standard Arm - Double Egress
- Track Arms

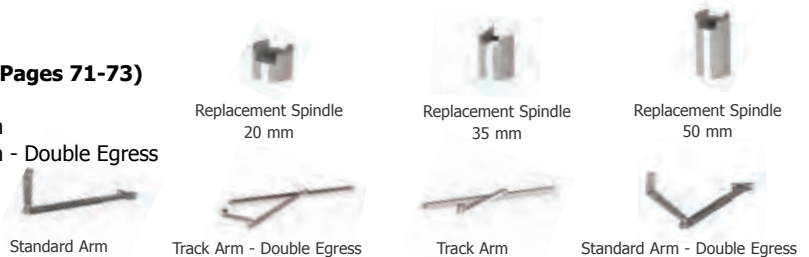

### 3 Actuators (Pages 75-84)

- 4.5" Square Actuator
- 6" Square Actuator
- 4.5" Round Actuator
- 6" Round Actuator
- 1.5" x 4.75" Jamb Actuator
- 36" Low Profile Actuator
- 4.75" Vestibule Actuator
- Bollard Posts

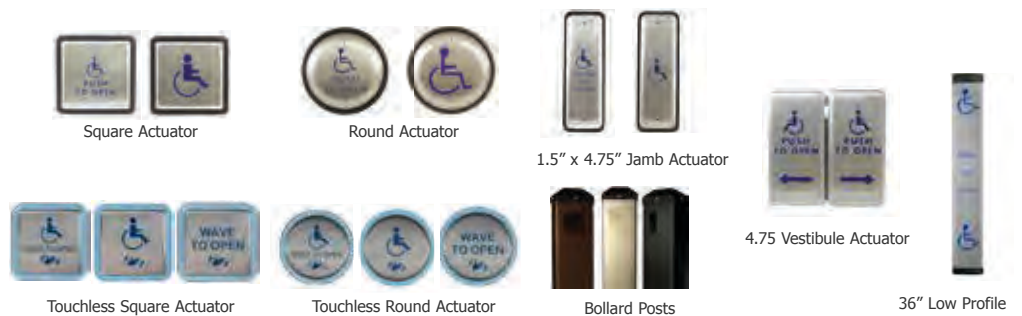

### 4 Accessories (Pages 85-87)

- 433 MHz Receiver
- 3-Volt Wireless Transmitter
- 9-Volt Wireless Transmitter
- Wireless, One Button Transmitter
- Programmable Relay and Door Sequencer

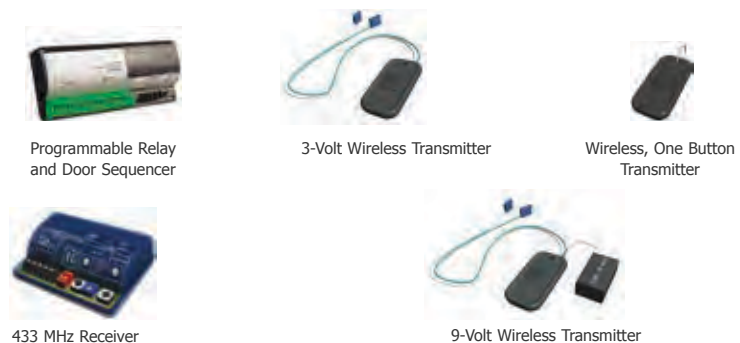



## 8400 SERIES LOW ENERGY POWER OPERATOR - STANDARD APPLICATIONS

Hager Companies 8400 Series Low Energy Power Operator meets ANSI/BHMA A156.19 standards for power assist and low energy operators and is designed to meet the requirements of door openings that occasionally have the need for an automatic opening. These devices can be used on single and double doors including double egress applications. This door opening solution provides a consistent closing and opening of the door, which is especially beneficial in situations that require compliance with the Americans with Disabilities Act (ADA). The use of Hager's Low Energy Power Operator provides easy access for not only people with disabilities, but also allows for manual operation of the door when necessary.

The 8400 Series is designed for ease of installation, allowing it to be installed by a single person. It also provides a quiet, smooth operation preventing any unwanted noise in the opening and surrounding area. The use of a digital display makes programming the operator uncomplicated and provides a resourceful tool for maintaining the device and assessing its status.

In addition to the Low Energy Power Operator, Hager offers a full range of actuators to be used in conjunction with the operator. The switches available for activation of the operator come in a variety of sizes and options, including wireless and hard wired. Hager also offers an option that exceeds the California Building Code, Section 1117B.6 by providing a push plate that meets height, reach range, and operation requirements for those with disabilities.

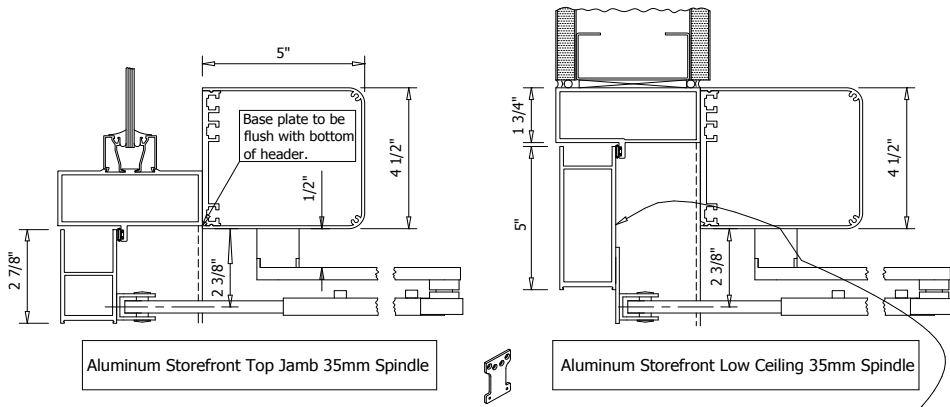

**Note: Optional arm shoe drop plate is available for applications with a top rail less than 5". See page 9 for additional information.**

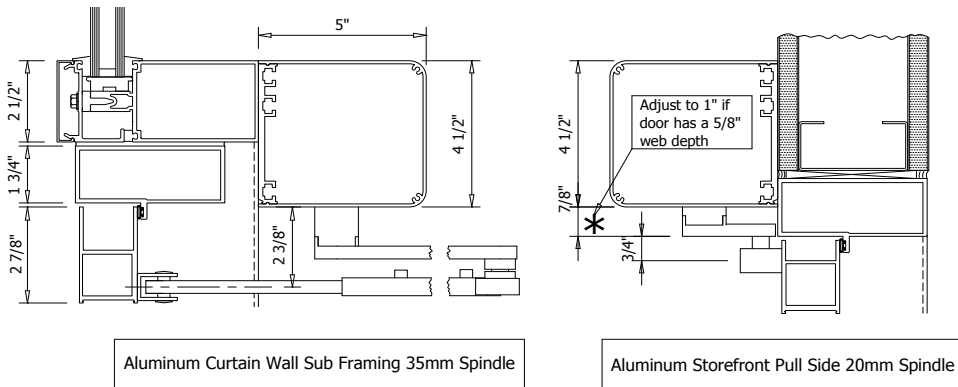



# 8400 SERIES LOW ENERGY POWER OPERATOR - STANDARD APPLICATIONS

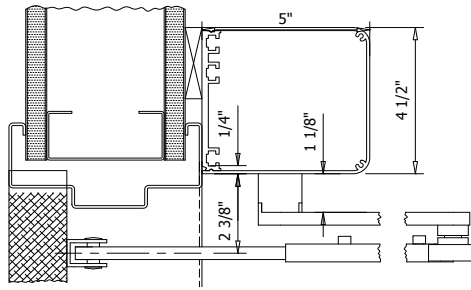

Hollow Metal Top Jamb Push 35mm Spindle

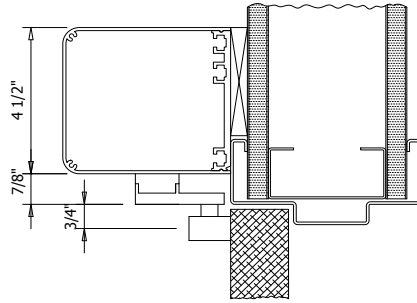

Hollow Metal Pull Side 20mm Spindle

## SINGLE OPERATOR

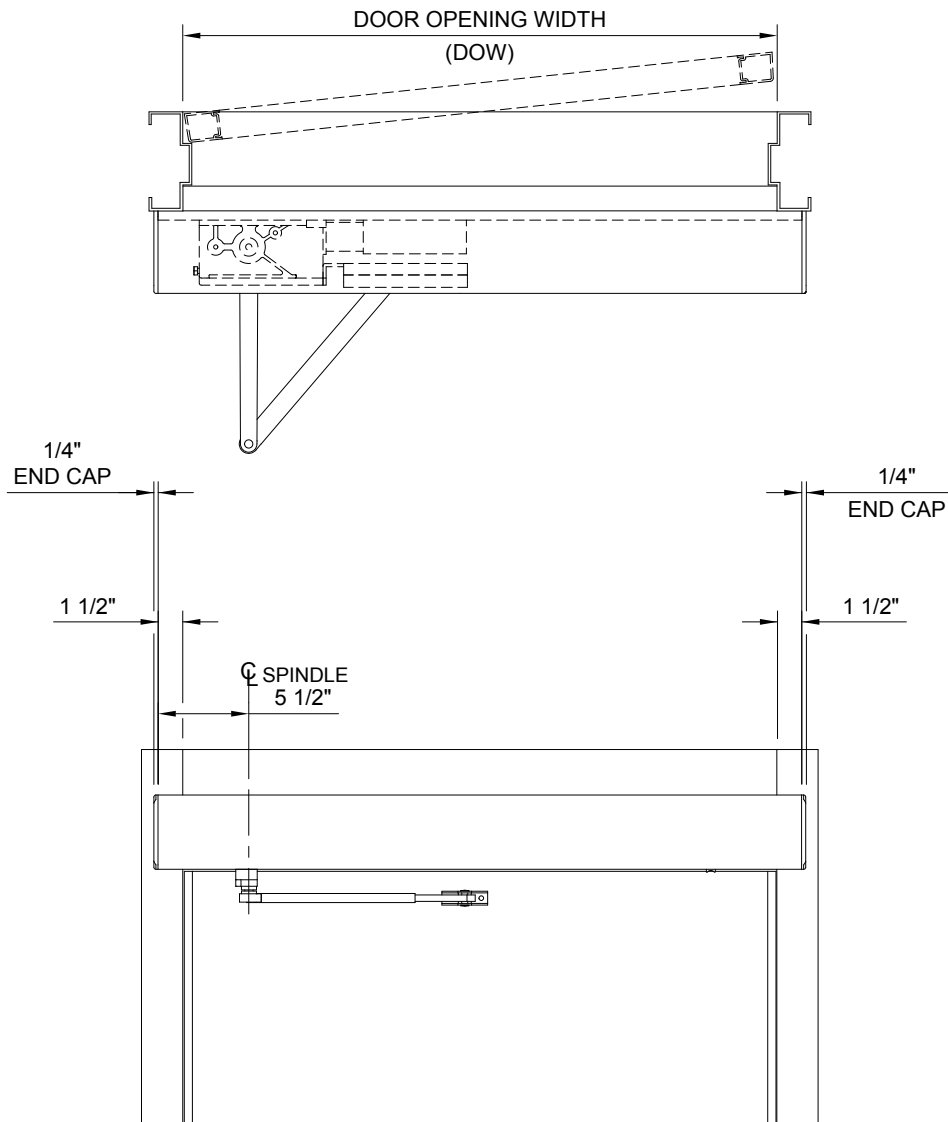

# 8400 SERIES LOW ENERGY POWER OPERATOR - STANDARD APPLICATIONS

## PAIRED OPERATOR

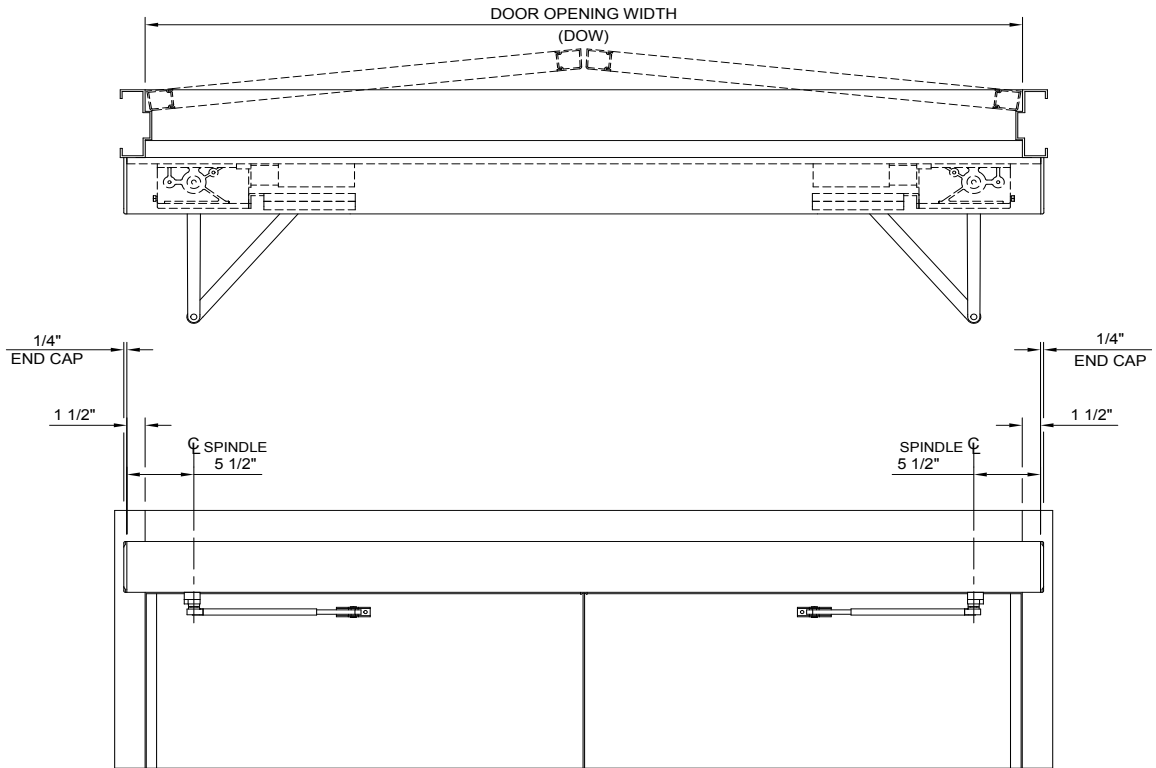

## DOUBLE EGRESS OPERATOR

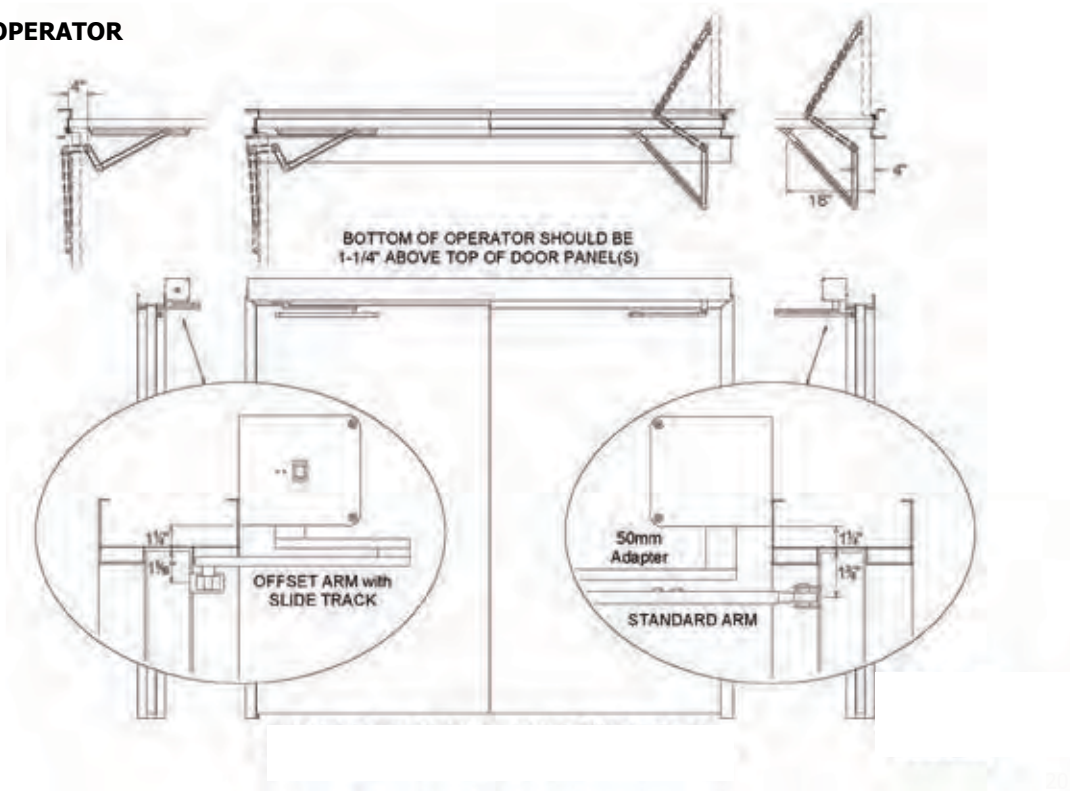



# 8400 SERIES LOW ENERGY POWER OPERATOR - STANDARD APPLICATIONS

## SINGLE OPERATOR PAIRED WITH MECHANICAL CLOSER

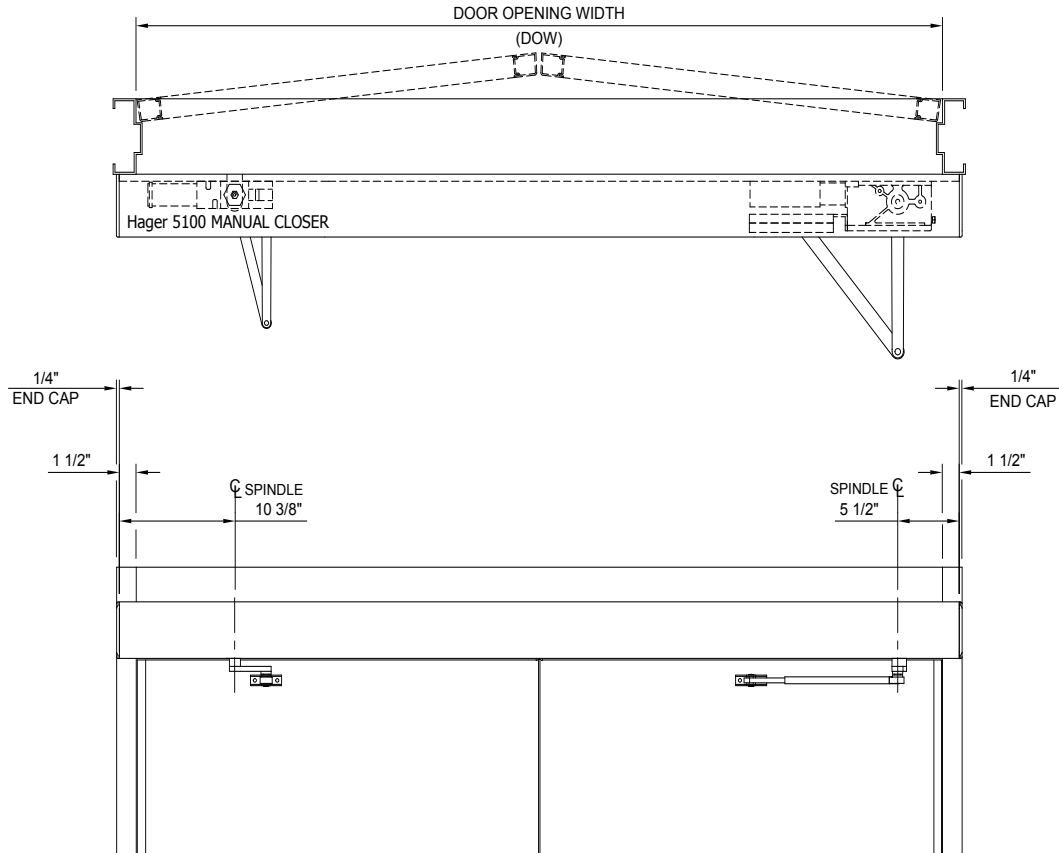

## OPERATOR HANDING IDENTIFICATION

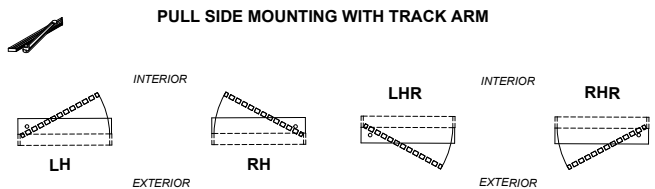
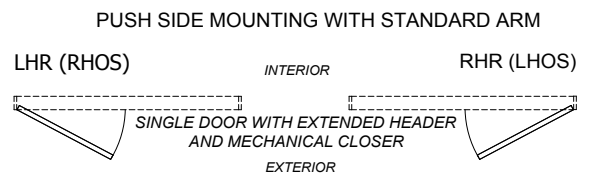
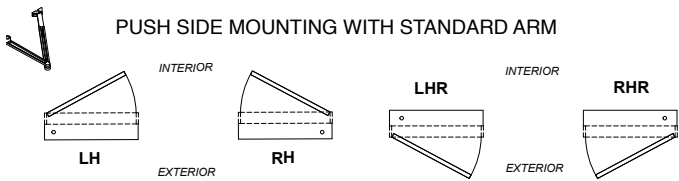

**Note: Specify leaf to receive operator.**

## 8400 SERIES LOW ENERGY POWER OPERATOR - PARTS AND ASSEMBLY DETAILS

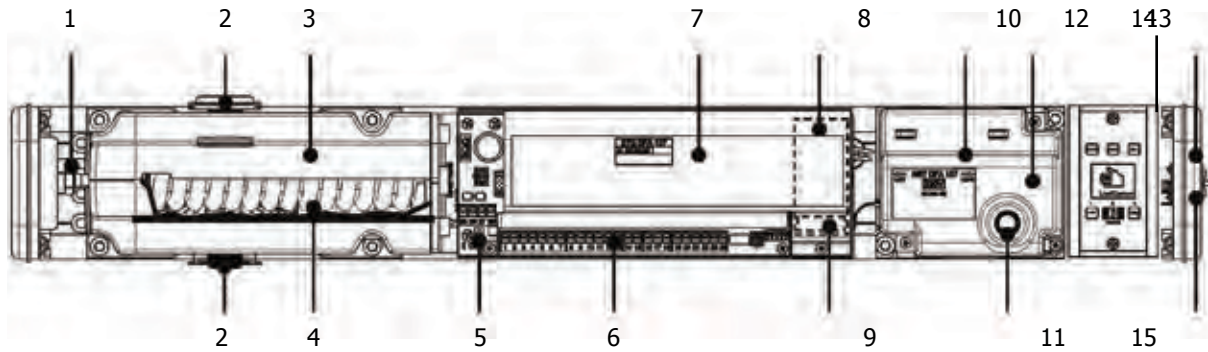

- |                                       |   |
|---------------------------------------|---|
| 1. Adjusting screw for spring tension | 8. Motor drive circuit board            |
| 2. Output shafts for arms & stop      | 9. Slide switch S1 (rotating direction) |
| 3. Drive unit                         | 10. Power supply                        |
| 4. Closing spring                     | 11. Fuse (2.0A, 5 x 20mm, Slo-Blo)      |
| 5. Multifunction push button/control  | 12. Power supply circuit board          |
| 6. Terminal blocks for I/O            | 13. Onboard programmer                  |
| 7. Microprocessor control             | 14. On/Off/Open rocker switch           |
|                                       | 15. Status LED and reset push button    |





## 8400 SERIES LOW ENERGY POWER OPERATOR - HOW TO ORDER

### 8400 SERIES

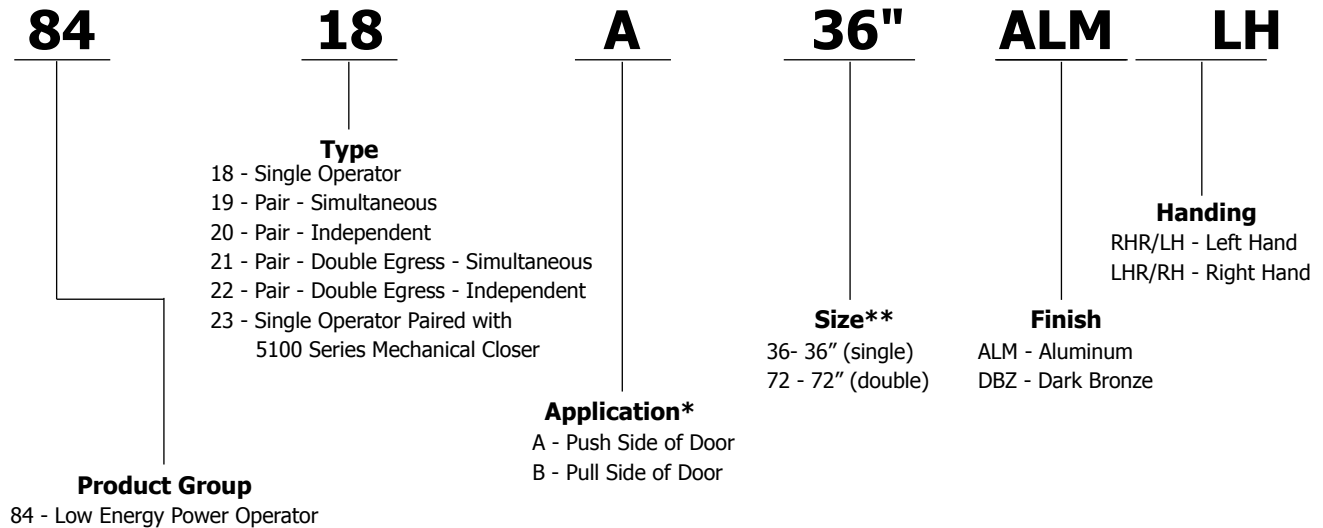

**\* Note: Push side of door comes with standard arm. Pull side of door comes with track arm.**

**\*\* Additional sizes available. See page 7 for additional information.**

**\* Note: Standard arm (push side, 0" - 4.1875" reveal) included.**

## 8400 SERIES LOW ENERGY POWER OPERATOR

### MODELS

8418	Single Operator (handed)	
8419	Simultaneous Pair (2 units, 1 controller, doors operate at the same time) For use with Hager mortise locks with deadbolt	
8420	Independent Pair (2 units, 2 controller, doors operate independently from each other)	
8421	Double Egress Simultaneous Pair (2 units, 1 controller, doors swing in opposite directions at same time)	
8422	Double Egress Independent Pair (2 units, 2 controller, doors swing in opposite directions at different times)	
8423	Single operator paired with 5100 Series closer for inactive door (handed)	

### WARRANTY

Two-year warranty

### APPLICATION

- For use on fire-rated and non-fire-rated outswing or inswing doors
- Built-in adjustable door stop for protection against wind or abusive environments
- Operates as a manual closer with or without power

### FEATURES

Application Features:

- Single person installation
- Pre-drilled mounting holes for ease of installation
- Three Operating Modes (On/Off/Hold Open)
- Designed for single doors from 36" to 48" (914 mm to 1,219 mm)
- Designed for double doors from 60" to 96" (1,524 mm to 2,438 mm)
- On-board power supply

Operational Functionality:

- Built-in adjustable door stop for protection against wind or abusive environments
- Interfaces with electric door hardware
- Operates as a mechanical closer if power is disconnected
- Obstacle recognition upon opening and closing
- Blow open function for smoke ventilation

Programmable Functionality:

- Boost on Close (selectable On/Off)
- Power Assist Close
- Power Boost Close - motor assist under wind and stack pressure
- Motor Hold Close
- Power Open and Hold - for smoke evacuation
- Adjustable Opening Force Limitation
- Adjustable Opening and Closing Speeds
- Adjustable Opening Angle
- Adjustable Hold Open Time for Door Activators (1 sec to continuous)
- Sequential Operation (push to open/push to close operation)
- Built-In Stop - Manual swing to 180°/ Power swing to 100°
- Fire Alarm input shunts swing activations until FACP is manually reset
- Internal LCD display
- Memory is flash upgradeable

Certification:

- ANSI A156.19 compliant
- UL/cUL Listed for up to 3-hours
- UL10C Listed for Positive Pressure Rating
- ADA compliant





## 8400 SERIES LOW ENERGY POWER OPERATOR

### ELECTRICAL SPECIFICATIONS

Power Requirements:	115 VAC 60 HZ
Current Draw:	3A
Auxiliary Output Voltage:	500mA @ 24 VDC
Fuse Type:	2.0A, 5 x 20mm, Slo-Blo
Electric Lock Relay Type:	Form "C" SPDT
Lock Relay Rating:	5.0A @ 28 VDC
Operating Temperature:	-40° to 140° F (-40° to 160° C) ambient operating temperature in all climatic conditions

### MECHANICAL SPECIFICATIONS

Dimensions:	5" H x 4-1/2" W x door width +3" L (127 mm x 114 mm)
Reveal:	Up to 12" standard
Spring Adjustment:	5 lbs to 20 lbs closing force
Max Degree of Swing:	180°
On/Off/Hold Open Switch:	Standard
Swing Direction:	Inswing/Outswing
Adjustable Swing Degree:	80° to 180°

### FINISHES

ALM	Aluminum anodized (standard)
DBZ	Dark bronze anodized

### NOTES

Must specify push or pull side mount  
Specify handing





# 8400 Series Parts & Accessories



In this section, you can find the various arms and spindles for the 8400 Series operator.





**2-659-0151 | 2-659-0152**

**Track Arm**

- 20 mm spindle
- For use on pull side of the door
- 2-659-0151 is ALM, 2-659-0152 is DBZ

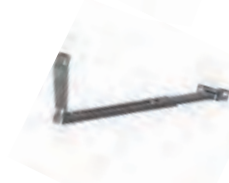

**2-659-0153 | 2-659-0154**

**Standard Arm**

- 35 mm spindle
- For use on push side of the door
- 2-659-0153 is ALM, 2-659-0154 is DBZ



**2-659-0220 | 2-659-0221**

**Standard Arm - Double Egress**

- 50 mm spindle
- For use on push side of the door
- 2-659-0220 is ALM, 2-659-0221 is DBZ



**2-659-0222 | 2-659-0223**

**Track Arm - Double Egress**

- 20 mm spindle
- Offset adaptor
- For use on pull side of the door
- 2-659-0222 is ALM, 2-659-0223 is DBZ



**2-659-0224 | 2-659-0225**

**Replacement Spindle**

- 20 mm
- For use with delayed egress or track arm assembly
- 2-659-0224 is ALM, 2-659-0225 is DBZ



**2-659-0226 | 2-659-0227**

**Replacement Spindle**

- 35 mm
- For use with standard single and standard pair applications
- 2-659-0226 is ALM, 2-659-0227 is DBZ



**2-659-0228 | 2-659-0229**

**Replacement Spindle**

- 50 mm
- For use with push side standard arm - double egress only
- 2-659-0228 is ALM, 2-659-0229 is DBZ



## ACCESSORIES



### **2-659-0230 | 2-659-0231** **Drop Plate**

- For use with low ceiling clearance
- 2-659-0230 is ALM, 2-659-0231 is DBZ

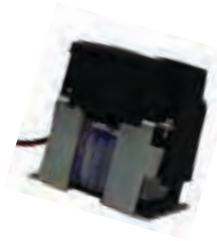

### **2-659-0236** **Power Supply**

- On-board replacement
- Power requirements: 115 VAC 60 Hz
- Output Voltage: 24 VDC 500mA



### **2-659-0232 | 2-659-0233** **Cover for Single Operator**

- 36" length - contact Hager Tech Support for special sizes
- Powder coated
- Anodized aluminum
- 2-659-0232 is ALM, 2-659-0233 is DBZ



### **2-659-0234 | 2-659-0235** **Cover for Dual Operators**

- 72" length - contact Hager Tech Support for special sizes or 8423 cover
- Powder coated
- Anodized aluminum
- 2-659-0234 is ALM, 2-659-0235 is DBZ

**Note: For additional replacement parts contact Hager Tech Support.**



# 8200 Series Low Energy Power Operator



The 8200 Series is Hager's economy low energy power operator. The modular platform allows installers to order the features they need.



## 8200 SERIES LOW ENERGY POWER OPERATOR - HOW TO ORDER

### 8200 SERIES

**82**

**Product Group**

82 - Economy Low Energy Power Operator

**18**

**Type**

18 - Single Operator  
19 - Simultaneous Pair  
22 - Double Egress Simultaneous Pair

**0**

**Default**

**31"**

**Size**

31- 31.5"  
51 - 51.5"

**ALM**

**Finish**

ALM - Aluminum  
DBZ - Dark Bronze





## 8200 SERIES LOW ENERGY POWER OPERATOR

### MODELS

8218	Single Operator
8219	Simultaneous Pair
8221	Double Egress Simultaneous Pair



### WARRANTY

One-year warranty

### APPLICATION

- For use on interior and exterior non-fire-rated outswing or inswing doors with butt hinges, offset pivots and center pivots
- On-board provisions for door status, battery backup and additional modules

### FEATURES

Application Features:

- Operates as a manual closer with or without power

- Non-Handed
- Three Operating Modes (On/Off/Hold Open)
- Designed for doors up to 48" wide (1219 mm)
- Designed for doors up to 275 lbs. (125 Kg)

Operational Functionality:

- Power Open Spring Close
- 1/4+ HP DC Motor
- Motor Protection Circuit - interrupts motor when there is an obstruction during opening

Certification:

- ANSI A156.19 compliant
- ANSI/UL 325 listed for both United States and Canada
- ADA compliant

Optional Programming and Features:

- *Modular design allows for additional optional modules to be installed to fit any application*
- *Control over electrified door hardware including electric strikes, magnetic lock or motorized latch retraction (MLR)*
- *Sequencing of multiple doors in vestibule applications*
- *Programming changes to extend Hold Open Times, Push and Go, Boost to Close and more*
- *- See 8200 Accessories for additional information*

### ELECTRICAL SPECIFICATIONS

Power Supply: On-board 24VDC output for accessories

Operating Temperature:

+5° to 125° F (-15° to 50° C) ambient operating temperature in all climatic conditions

### MECHANICAL SPECIFICATIONS

Dimensions:

- Single: 4-9/16" H x 5" W x 31-1/2" L (116 mm x 127 mm x 800 mm)
- Pair: 4-9/16" H x 5" W x 75-1/2" L (116 mm x 127 mm x 1816 mm)

Standard Header Lengths:

- Single: 31.5" (800 mm)
- Single: 39.5" (1003 mm)
- Pair: 75.5" (1918 mm) up to 101.5" (2578 mm)
- Custom sizes up to 101.5" (2578 mm) available

Reveal:

- 0"-9.75" outswing
- 0"-6" Inswing

Opening Angles - Outswing:

Adjustable (0-110 degrees)

Opening Angles - Inswing:

Adjustable (0-110 degrees); Deep Reveal Arm Maximum (90 degrees)

### FINISHES

ALM  
DBZ

Aluminum anodized (standard)  
Dark bronze anodized







# 8200 Series Parts & Accessories



In this section, you can find the various arms and spindles for the 8200 Series operator.



## 8200 SERIES PARTS & ACCESSORIES - MODULES

- 2-659-0275
- Exterior Door Module (EDM) for 8200 Auto Operator
  - Provides On-Board 1.5A @ 24VDC Output for an Electric Strike, Magnetic Lock or Motorized Latch Retraction (MLR) Exit Device with (0.2 – 4.0s) delay
  - Requires iMotion programmer (2-659-0280)
  - Allows for daylight operation



2-659-0275

- 2-659-0276
- Multiple Door Module (MDM-B) for 8200 Auto Operator
  - Allows for operation of double leaved doors

Programmer:  
2-659-0277

Programming Interface Module (PIM) for 8200 Auto Operator



2-659-0277

2-659-0280

iMotion Programmer w/ 6' Cord

Battery Backup:  
2-659-0278

Battery Backup with Interface Cable for 8200 Auto Operator  
Note: 33" minimum header length on singles, and 36" for pairs



2-659-0280

2-659-0279

Battery Backup Extension Harness for 8200 Auto Operator

Programmable  
Functionality:

- Push and Pull (selectable On/Off)
- Power Assist Close
- Power Boost Close - motor assist under wind and stack pressure
- Motor Hold Close
- Power Open and Hold - for smoke evacuation
- Adjustable Opening Force Limitation
- Adjustable Opening and Closing Speeds
- Adjustable Opening Angle
- Adjustable Hold Open Time for Door Activators (0 - 60 sec.)
- Sequential Operation (push to open/push to close operation)
- Built-In Safety Circuit w/ Stall/Carpet/Safety Slow/Reactivation
- Stall: when door is in motion, most commonly used with pull side door mounted sensor, the door stops before contact is made.
- *Carpet: used with an over head presence sensor, keeps a closed door closed and an open door open*
- *Safety slow: used with a door mounted sensor on pull side, opens the door very slow*



## 8200 SERIES PARTS & ACCESSORIES

### Arm & Assemblies

- 2-659-0287 Push Side Arm Door Assembly (0 - 4.1875" reveal) CLR (standard arm)
- 2-659-0288 Push Side Arm Door Assembly (0 - 4.1875" reveal) BLK (standard arm)
- 2-659-0289 Push Side Arm Door Assembly (4.125 - 9.875" reveal) CLR
- 2-659-0290 Push Side Arm Door Assembly (4.125 - 9.875" reveal) BLK
- 2-659-0291 Double Egress Push Side Arm Door Assembly (0 - 4.1875" reveal) CLR (standard arm)
- 2-659-0292 Double Egress Push Side Arm Door Assembly (0 - 4.1875" reveal) BLK (standard arm)
- 2-659-0293 Double Egress Push Side Arm Door Assembly (4.125 - 9.875" reveal) CLR
- 2-659-0294 Double Egress Push Side Arm Door Assembly (4.125 - 9.875" reveal) BLK
- 2-659-0295 Pull Side Door Arm and Slide Track (0" reveal) CLR
- 2-659-0296 Pull Side Door Arm and Slide Track (0" reveal) BLK
- 2-659-0297 RH Pull Side Deep Reveal Arm and Track (0 - 6" reveal) CLR
- 2-659-0298 RH Pull Side Deep Reveal Arm and Track (0 - 6" reveal) BLK
- 2-659-0299 LH Pull Side Deep Reveal Arm and Track (0 - 6" reveal) CLR
- 2-659-0300 LH Pull Side Deep Reveal Arm and Track (0 - 6" reveal) BLK

### Drive Shaft Arms

- 2-659-0283 2.65" Drive Shaft Arm (double egress/deep reveal)
- 2-659-0284 3.22" Drive Shaft Arm (standard in & out)
- 2-659-0285 3.94" Drive Shaft Arm (special applications)
- 2-659-0286 4.84" Drive Shaft Arm (double egress out)



# Actuators



Actuators are what allow the “knowing act” of a low energy operator. Hager offers various styles and types of actuators that will appeal to every installation. The typical 4.5” and 6” square or round actuators are available along with Hager’s line of jamb operators. For more unique installations or installations with wheelchair traffic, refer to the low profile actuators that can be activated in a 36” range from ground up.



## LOW ENERGY POWER OPERATOR ACTUATORS - TOUCHLESS ACTUATORS

### MODELS

2-659-0303	6" round with text & handicap logo
2-659-0304	6" round with handicap logo only
2-659-0307	6" round with text only
2-659-0305	4.75" square with text & handicap logo
2-659-0306	4.75" square with handicap logo only
2.659-0308	4.75" square with text only

### WARRANTY

One-year warranty

### APPLICATION

- For use with ADA low energy power operators
- Employs capacitance technology simliar to smart devices to operate low energy doors
- Ideal installations include medical facilities, assisted living facilities, offices, clean rooms, and schools

### FEATURES

- Touchless design reduces the spread of bacteria and germs
- LED illumination increases plate visibility
- Stainless steel faceplate provides durability while also reducing visible deterioration caused by abrasive cleaning agents
- Beveled edges
- Various design options
- Adjustable detection zone
- Audible alert (selectable On/Off)

Certification: NEMA rated

### SPECIFICATIONS

Finish:	US32D with text and/or blue logo
Faceplate:	16 gauge, 304 stainless steel
Backplate:	Illuminated Mounting Ring
Input:	30 mA @ 12 to 24 VAC/VDC
Operating Temperature:	-20° to 120°F (-30° to 49°C)
Fasteners:	6-32 x 3/4" mounting screws





## LOW ENERGY POWER OPERATOR ACTUATORS - 4.5" SQUARE ACTUATOR

### MODELS

2-659-0172	4.5" square with text & handicap logo
2-659-0173	4.5" square with handicap logo only

### WARRANTY

One-year warranty

### APPLICATION

- For use with ADA low energy power operators
- Ideal installations include medical facilities, assisted living facilities, offices, clean rooms, and schools

### FEATURES

- Hard wired (standard) with wireless option
- Embossed graphics ensures durability
- Stainless steel faceplate provides durability while also reducing visible deterioration caused by abrasive cleaning agents
- Beveled edges

**Note: for wireless version, must order receiver and transmitter separately**

Certification: NEMA rated

### SPECIFICATIONS

Finish:	US32D with text and/or blue logo
Faceplate:	16 gauge, 304 stainless steel
Backplate:	1/8" thick aluminum
Cherry Switch:	Single-pole, 15A/COM/NO/NC contacts
Operating Temperature:	-20° to 120°F (-30° to 49°C)
Fasteners:	6 - 3/2" x 1" and 8 - 3/2" x 1" Allen head mounting screws

### OPTIONS

2-659-0174	<p>Surface Mount Box for 4.5" Square Actuator</p> <ul style="list-style-type: none"> <li>• Provides adequate space for wireless transmitters</li> <li>• Simplified installation for applications with space limitations</li> <li>• Black finish</li> </ul>
2-659-0241	<p>Universal Backplate</p> <ul style="list-style-type: none"> <li>• For use when mounting actuator to bollard post</li> <li>• Stainless steel finish</li> </ul>





## LOW ENERGY POWER OPERATOR ACTUATORS - 6" SQUARE ACTUATOR

### MODELS

2-659-0169 6" square with text & handicap logo  
 2-659-0170 6" square with handicap logo only

### WARRANTY

One-year warranty

### APPLICATION

- For use with ADA low energy power operators
- Ideal installations include medical facilities, assisted living facilities, offices, clean rooms, and schools

### FEATURES

- Hard wired (standard) with wireless option
- Embossed graphics ensures durability
- Stainless steel faceplate provides durability while also reducing visible deterioration caused by abrasive cleaning agents
- Beveled edges

**Note: for wireless version, must order receiver and transmitter separately**

Certification: NEMA rated

### SPECIFICATIONS

Finish: US32D with text and/or blue logo  
 Faceplate: 16 gauge, 304 stainless steel  
 Backplate: 1/8" thick aluminum  
 Cherry Switch: Single-pole, 15A/COM/NO/NC contacts  
 Operating Temperature: -20° to 120°F (-30° to 49°C)  
 Fasteners: 6-32 x 1" and 8-32 x 1" Allen head mounting screws

### OPTIONS

2-659-0171 Surface Mount Box for 6" Square Actuator

- Provides adequate space for wireless transmitters
- Simplified installation for applications with space limitations
- Black finish





## LOW ENERGY POWER OPERATOR ACTUATORS - 4.5" ROUND ACTUATOR

### MODELS

2-659-0165 4.5" round with text & handicap logo

2-659-0166 4.5" round with handicap logo only

### WARRANTY

One-year warranty

### APPLICATION

- For use with ADA low energy power operators
- Ideal installations include medical facilities, assisted living facilities, offices, clean rooms, and schools

### FEATURES

- Hard wired (standard) with wireless option
- Embossed graphics ensures durability
- Stainless steel faceplate provides durability while also reducing visible deterioration caused by abrasive cleaning agents
- Beveled edges

**Note: for wireless version, must order receiver and transmitter separately**

Certification:

NEMA rated

### SPECIFICATIONS

Finish: US32D with text and/or blue logo

Faceplate: 16 gauge, 304 stainless steel

Backplate: 1/8" thick aluminum

Cherry Switch: Single-pole, 15A/COM/NO/NC contacts

Operating Temperature: -20° to 120°F (-30° to 49°C)

Fasteners: 6-32 x 1" and 8-32 x 1" Allen head mounting screws

### OPTIONS

2-659-0167 Surface Mount Box for 4.5" Round Actuator

- Provides adequate space for wireless transmitters
- Simplified installation for applications with space limitations
- Black finish

2-659-0168 Weather Ring for 4.5" Round Actuator

- Provides protection against moisture and weather elements

2-659-0241 Universal Backplate

- For use when mounting actuator to bollard post
- Stainless steel finish



## LOW ENERGY POWER OPERATOR ACTUATORS - 6" ROUND ACTUATOR

### MODELS

- 2-659-0161 6" round with text & handicap logo
- 2-659-0162 6" round with handicap logo only

### WARRANTY

One-year warranty

### APPLICATION

- For use with ADA low energy power operators
- Ideal installations include medical facilities, assisted living facilities, offices, clean rooms, and schools

### FEATURES

- Hard wired (standard) with wireless option
  - Embossed graphics ensures durability
  - Stainless steel faceplate provides durability while also reducing visible deterioration caused by abrasive cleaning agents
  - Beveled edges
- Note: for wireless version, must order receiver and transmitter separately**

Certification: NEMA rated

### SPECIFICATIONS

- Finish: US32D with text and/or blue logo
- Faceplate: 16 gauge, 304 stainless steel
- Backplate: 1/8" thick aluminum
- Cherry Switch: Single-pole, 15A/COM/NO/NC contacts
- Operating Temperature: -20° to 120°F (-30° to 49°C)
- Fasteners: 6-32 x 1" and 8-32 x 1" Allen head mounting screws

### OPTIONS

- 2-659-0163 Surface Mount Box for 6" Round Actuator
  - Provides adequate space for wireless transmitters
  - Simplified installation for applications with space limitations
  - Black finish
- 2-659-0164 Weather Ring for 6" Round Actuator
  - Provides protection against moisture and weather elements





## LOW ENERGY POWER OPERATOR ACTUATORS - 1.5" x 4.75" JAMB ACTUATOR

### MODELS

2-659-0175  
2-659-0176

Push to Open text and handicap logo  
Handicap logo only

### WARRANTY

One-year warranty

### FEATURES

- Hard wired (standard) with wireless option
- Embossed graphics ensures durability
- Stainless steel faceplate provides durability while also reducing visible deterioration caused by abrasive cleaning agents
- Beveled edges

**Note: for wireless version, must order receiver and transmitter separately**

Certification:

- NEMA rated

### SPECIFICATIONS

Finish:

US32D with text and/or blue logo

Faceplate:

16 gauge, 304 stainless steel

Backplate:

1/8" thick aluminum

Cherry Switch:

Single-pole, 15A/COM/NO/NC contacts

Operating Temperature:

-20° to 120°F (-30° to 49°C)

Fasteners:

6-32 x 1" and 8-32 x 1" Allen head mounting screws

### OPTIONS

2-659-0177

Surface Mount Box for 1.5" x 4.75" Jamb Actuator

- Provides adequate space for wireless transmitters
- Simplified installation for applications with space limitations
- Black finish



## LOW ENERGY POWER OPERATOR ACTUATORS - 36" LOW PROFILE ACTUATOR

### MODELS

- 2-659-0178 Push to Open text and handicap logo - Wireless  
2-659-0179 Push to Open text and handicap logo - Hard wired

### WARRANTY

One-year warranty

### APPLICATION

- For use with ADA low energy power operators
- Ideal installations include medical facilities, assisted living facilities, offices, clean rooms, and schools

### FEATURES

- Mounts to any flat surface
- Embossed graphics ensures durability
- Stainless steel faceplate provides durability while also reducing visible deterioration caused by abrasive cleaning agents
- Weather resistant
- Beveled edges
- 36" x 36" activation area and low profile 1" depth
- Four separate switches to allow activation from any angle
- Exceeds California Building Code, Section 1117B.6

Certification: NEMA Rated

### SPECIFICATIONS

- Finish: US32D with text and/or blue logo
- Faceplate: 16 gauge, 304 stainless steel
- Backplate: 1/8" thick aluminum
- Transmitter Frequencies: 433 MHz
- Dimensions: 6" (152 mm) W x 36" (990 mm) H x 1 (25 mm) D
- Fasteners: Due to various mounting types, no fasteners are supplied with the actuator





## LOW ENERGY POWER OPERATOR ACTUATORS - 4.75" VESTIBULE ACTUATOR

### MODEL

2-659-0242 | Push to Open text and logo

### WARRANTY

One-year warranty

### APPLICATION

- For use with ADA low energy power operators
- Ideal installations include medical facilities, assisted living facilities, offices, clean rooms, and schools

### FEATURES

- Hard wired (standard) with wireless option
- Embossed graphics ensures durability
- 304 grade stainless steel finish - scratch resistant
- Interfaces with 2-659-0187 Programmable Relay and Door Sequencer for automatic sequencing applications
- Conserves energy and provides entrapment protection
- Beveled edges



### SPECIFICATIONS

Finish: US32D with blue text and logo

Faceplate: 16 gauge, 304 stainless steel

Base Material: 1/8" thick aluminum

Cherry Switch: Single-pole, 15A, COM/NO/NC contacts

Compatible Wireless Frequencies: 433 MHz

Fasteners: 6 - 3/2" x 1", 8 - 3/2" x 1" stainless steel

### OPTIONS

2-659-0243 | Surface Mount Box for 4.75" Vestibule Actuator

- Provides adequate space for wireless transmitters
- Simplified installation for applications with space limitations
- Black finish



## LOW ENERGY POWER OPERATOR ACTUATORS - BOLLARD POST

### MODELS

2-659-0180  
2-659-0181  
2-659-0182

Black Powder Coat  
Bronze Powder Coat  
Silver Powder Coat

### WARRANTY

One-year warranty

### FEATURES

- For use with Hager's 4.5" square (2-659-0172 | 2-659-0173) and 4.5" round (2-659-0165 | 2-659-0166) actuators
- Can be mounted on existing or newly poured concrete
- UV resistant plastic cap allows for wireless transmissions

### SPECIFICATIONS

Material:	Carbon steel
Mounting Bracket:	Stainless steel
Dimensions:	41.5" H x 6.25" W x 4.25" D (with cap attached)
Weight:	35 lbs.
Fasteners:	Screws, expansion anchors, washers and nuts
Note:	Push plates not included - must order separately



# Accessories



Accessories can make any ordinary installation unique. Hager offers different wireless transmitters and receivers that are commonly used in executive installations or other high automated installations.





## ACCESSORIES



**433 MHz Transmitters and Receiver**



**2-659-0237 RELAY BOARD**

- 24VDC
- Current draw: 40mA
- Contact rating : 5amp/220 VAC or 28VDC DPDT contacts

- Universally compatible with any type of automatic door application
- Used for wireless activation or sequencing of doors
- Receiver can be programmed with up to 100 transmitters
- Activation of transmitter utilizes a rolling code providing a protected signal

### MODELS



**2-659-0183 433MHz Receiver**



**2-659-0185 9-Volt Wireless Transmitter (Hardwired to Hager Actuators)**



**2-659-0184 3-Volt Hard Wireless Transmitter (Hardwired to Hager Actuators)**



**2-659-0186 Wireless, One Button Transmitter**

### FEATURES

- Transmitters can be programmed to multiple receivers
- Optional delay - no delay programming
- Toggle or pulse mode selectable by DIP switch
- Red LED on receiver verifies transmission and delivers troubleshooting assistance
- Red LED on transmitter ensures transmission and battery life
- Wire leads plug into terminals on Hager actuators - 2-659-0184 and 2-659-0185

### SPECIFICATIONS

Frequency:	433 MHz
Input Voltage:	12 to 24 VAC/VDC
Radio Control Type:	Digital
Emitted Radio Power:	-28.7dBm (transmitter)
Number of Transmitters per Receiver:	100 maximum transmitters
LED Functions:	Red = Relay Activity Blue = Receiver / Transmitter Learn
Dimensions:	Receiver - 2.75" x 2.125" x 1.0" Transmitter - 2.75" x 1.375" x 0.6"
Certifications:	CE, FCC, IC





## ACCESSORIES



### 2-659-0240

#### Programmable Relay and Door Sequencer

- Provides a single solution for a variety of applications
- Three relays; two 3-AMP and one 1-AMP
- Built-in surge suppression eliminates the need for external components when installing electric locking devices
- Capable of door timing and advanced relay sequencing

#### FUNCTIONS

FUNCTION	SUBJECT	MOST COMMON APPLICATIONS
<b>10</b> (MC10)	Simple Timer	Time delay relay
<b>11</b> (MC11)	Ratchet / Latching	Push to open / Push to close
<b>21</b> (LE21)	Inhibitor with Door Position Input	Automatic swing door with push plate, approach side SuperScan is inhibited when door is closed
<b>22</b> (LE22)	2 relay Sequence Inhibitor with Door Position Input	Automatic swing door with push plate, approach side SuperScan and Electric Strike. SuperScan is inhibited when door is closed
<b>25</b> (MC25)	2 Relay Sequence	Automatic swing door with a push plate and electric locking devices
<b>28</b> (MC28)	2 Relay Sequence with Door Position Input	Automatic swing door with a push plate and electric locking devices with a door position switch to prevent the delay from running during a recycle
<b>29</b> (MC29)	Relay 1 Deactivation Timer	Automatic swing door or sliding door with an electric locking device and door position switch to prevent lock from reengaging before door closes completely
<b>35</b> (MC35)	3 Relay Sequence	Two door vestibule with automatic swing doors and single electric locking device
<b>50</b> (M50)	Interlock Timer with Door Position Inputs	Interlock module that will only allow one door to open at a time and can be used with any automatic or manual door
<b>55</b> (M55)	Interlock Ratchet with Door Position Inputs	Interlock module that will only allow one door to open at a time with a ratchet / latching function and can be used with any automatic or manual door
<b>65</b> (M65)	2-Way, 2 Relay Sequence	Two door vestibule sequencing with automatic swing doors traveling in either direction
<b>75</b> (MC75)	2 Relay Sequence	Automatic swing door with a push plate and electric locking devices

#### SPECIFICATIONS

<b>Supply Voltage</b>	12 to 24 VAC / DC
<b>Power Consumption</b>	30 to 130 mA; DRY Output
<b>Temperature Range</b>	-15° to 150°F
<b>Dimensions</b>	5.2" x 2.2" x 1.0"
<b>Housing Material</b>	Gray ABS Plastic
<b>Input Specification</b>	1 to 4; DRY Contact
<b>WET Input</b>	5 to 24 VAC / DC
<b>Contact Rating DRY</b> Relay #1 Relay #2 Relay #3	3A @24VAC / 30VDC 3A @24VAC / 30VDC 1A @24VAC / 30VDC
<b>Contact Rating WET</b> Relay #1	1A

**Note: Functions 10, 11, 50, 55 and 65 are NOT compatible with the WET input.**



**One Family. One Brand. One Vision.™**

[www.hagerco.com](http://www.hagerco.com)

# Trim & Auxiliary



At Hager Companies, we know all about the importance of adding the finishing touches to your building projects. That's why we're proud to offer more than 200 different trim & auxiliary door hardware products in a variety of designs, sizes, and finishes that not only look great, but also provide long-lasting wear in any application. Whatever you need, from pulls to push plates, protection plates to door edgings, wall and floor stops to flush bolts, coordinators, signage, and much more - Hager trim & auxiliary products give you great looks and proven durability.

## Table of Contents

General Information .....	2
Pulls .....	5
Flush Cap Pulls .....	22
Pull Plates.....	26
Push Plates .....	28
Push Bars .....	32
Push & Pull Bar Sets.....	35
Door Edgings & Corner Guards .....	40
Door Protection Plates .....	42
Wall Stops & Holders.....	43
Roller Stops .....	48
Floor Stops & Holders.....	49
Kick Down Door Stops.....	56
Surface Bolts .....	57
Flush Bolts & Coordinating Devices .....	58
Latches & Protection Plates.....	65
Coat Hooks .....	69
Pulls - Closet/Pocket/Sliding Door.....	71
Filler Plates.....	74
Signage .....	76
Miscellaneous .....	81
Residential .....	85



## GENERAL INFORMATION

### MANUFACTURING OPTIONS

Hager Companies can deliver custom door pulls made to your specifications, or choose from our collection of pull designs. Hager's comprehensive selection of door pull hardware includes standard push/pull bars or multiple push bar combinations with center-to-centers made to order.

### PUSH/PULL PLATE DETAILS

#### Standard Grip Positions

Pulls are centered vertically or lowered when necessary to meet minimum top spacing requirement. Be certain the pull selected will fit on specified plate under these conditions.

#### Special Pull Positions

Where pairs of doors are involved and active leaf pull plate is lettered or has a cutout, order pull plate for inactive leaf Grip To Align (WOC). This will ensure horizontal alignment of pull on both plates. Always furnish complete details when ordering non-standard pull positions.

### PULL PLATES UP TO 4" WIDE

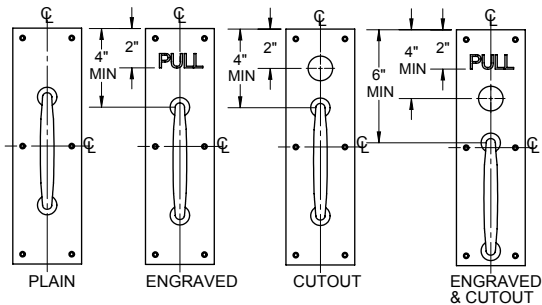

### PULL PLATES OVER 4" WIDE (HANDING REQUIRED WITH CUTOUTS)

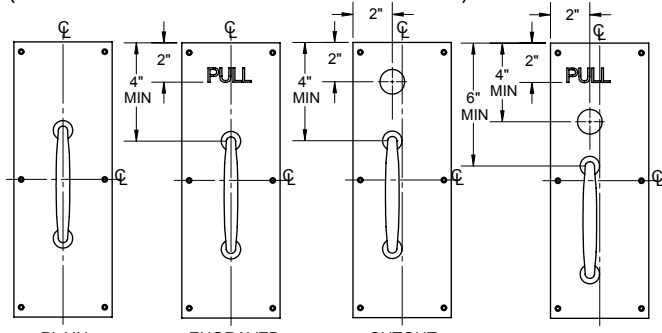

### Cut Outs

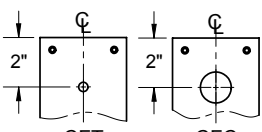

Standard cutout sizes: Cut for Cylinder (CFC) – 1 1/4" (32 mm) diameter; Cut for Thumbturn (CFT) – 3/8" (10 mm) diameter.

All plates may be ordered with cutout option by adding the appropriate suffix (i.e., 30S-CFC).

Standard cutouts are positioned 2" (51 mm) from top of plate where this option has been ordered. Cutouts are centered

on plates up to 4" (102 mm) wide or 2" (51 mm) from edge of plates over 4" (102 mm) wide. The latter are handed with cutouts. Furnish hand of door when ordering. Provide complete details for all non-standard cutouts.

### Flush Back Mounting

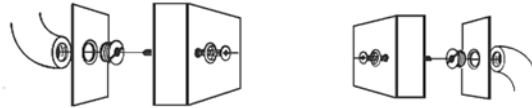

Pull plates using #3, 4, or 10 pull types can be furnished with a flush back (no projections). Specify code FB, (i.e., 33E-FB). Note: Use thru bolts supplied with mountings for best security.

### Back To Back Mounting

Many pulls may be ordered back to back (BTB) and availability will be noted on each particular product page (refer to product page). Specify the correct part number and center-to-center unless already specified.

### Handicap Option

Pulls that must meet the 2-1/2" (64 mm) clearance for ADA requirements are available. Must specify part number with prefix "H" (i.e., H2E). Please refer to each individual part number for availability.

### Engraving

Typical engraved lettering is in Helvetica style and colored black. On push or pull plates, standard position is horizontal on a line 2" (51 mm) from top of plate.

### PUSH PULL

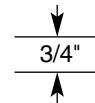



## GENERAL INFORMATION

### Fasteners

Illustrated below are various types of fasteners that can be furnished by Hager Companies. Please specify type of fastening desired. All types of fastening cannot be used with all items of hardware. If specified method is not possible, we reserve the right to furnish whatever type we feel is best suited for the installation. When used with tempered glass doors, specify thickness of glass and hole diameter. Fasteners are standard for 1-3/4" doors. Other door thicknesses are optional.



**Sex bolt and machine screws**  
(various sizes)



**Lead anchor**  
(used with floor stops in masonry applications)



**Plastic anchor and full threaded screw**  
(used in drywall or masonry applications)



**Lag screw and shield**

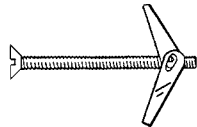

**Toggle bolt**  
(ideal for drywall applications)

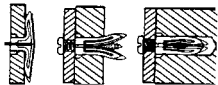

**Plastic toggle anchor**  
(used with wall stops in drywall applications)



**Thru-bolt and finish washer**  
(flat or oval head; size as required)



**Spanner head machine screws**  
(various sizes furnished at extra charge)



**Security torx head machine screws**  
(various sizes furnished at extra charge)

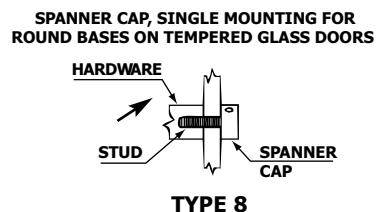
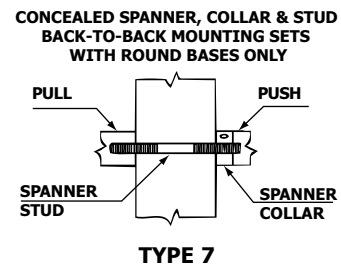
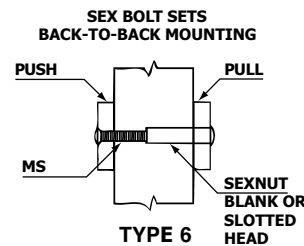
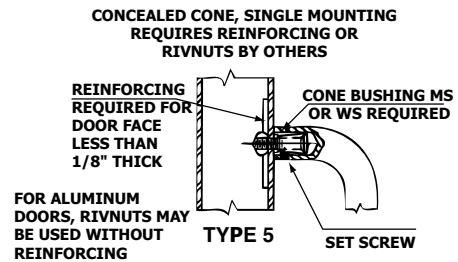
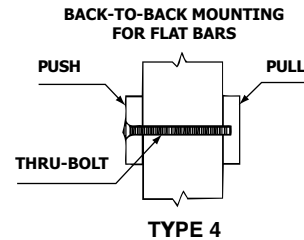
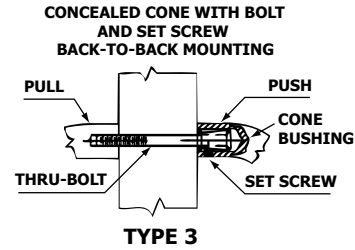
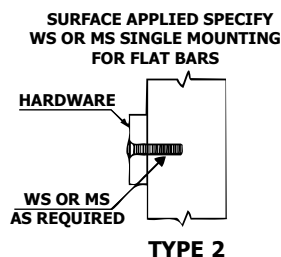
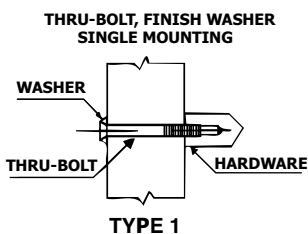

## GENERAL INFORMATION

### METAL FINISH SYMBOLS

US & Hager	Description	Base Material	BHMA Symbol
2C	Zinc Plated Steel	Steel	603
3	Bright Brass	Brass	605
4	Satin Brass	Brass	606
5	Satin Brass, Oxidized	Brass/Bronze	609
9	Bright Bronze	Brass/Bronze	611
10	Satin Bronze	Brass/Bronze	612
10B	Antique Bronze, Oiled	Brass/Bronze	613
10R	Matte Lacquer Antique Bronze	Brass/Bronze	-
15	Satin Nickel	Brass/Bronze	619
15A	Satin Nickel Oxidized	Brass/Bronze	620
19	Flat Black Coated	Brass	622
26	Bright Chromium Plated	Brass/Bronze	625
26D	Satin Chromium Plated	Brass/Bronze	626
28	Satin Anodized Aluminum	Aluminum	628
32	Stainless Steel Metal, Bright	300 Series	629
32D	Stainless Steel Metal, Satin	300 Series	630
L2	Duro	-	-
PC	Clear Plastic	-	-
PK	Plastic Laminate - Black	-	-
CO	Plastic Laminate - Chocolate	-	-
PG	Plastic Laminate - Grey	-	-
S1	Sprayed Aluminum	Cast Iron	-
S2	Sprayed Brass	Cast Iron	-
S3	Sprayed Bronze	Cast Iron	-

Note: For any finish not listed in this catalog, or explained above, availability on request.

### ANTIMICROBIAL PROTECTION

Hager Companies' full line of US32D stainless steel door pulls, push bars, push plates, and pull plates are available with AgION antimicrobial protection.

Hager uses a powder coat process to apply the antimicrobial treated coating to guarantee durability and protection. Antimicrobial resistance on products is affected by moisture in the air. Silver ions interact with humidity and are released creating a cleaner surface. The suppression of bacteria, mold and fungi is as easy as adding antimicrobial treated coating to your Hager products.

### Antimicrobial Vital Stats

- US32D stainless steel
- EPA registered
- NSF approved
- FDA listed for food contact
- Designate your product with: MV3 for Trim & Auxiliary





## PULLS



### 1

#### Modified Half Round Wrought Door Pull

- Certification: Meets ANSI A156.6 for J401 Pulls  
 Base: 1/2" x 1" (13 mm x 25 mm)  
 Projection: 2" (51 mm)  
 Clearance: 1-1/2" (38 mm)  
 Door Thickness: 1-3/4" (45 mm) - Standard  
 Materials: Aluminum, brass, bronze, stainless steel  
 Finishes: US3, US4, US10, US10B, US26, US26D, US28, US32, US32D  
 Fasteners: Two (2) 1/4-20 x 2-1/4" FPHMS with finish washers  
 Handicap:
  - 2-1/2" (64 mm) clearance available on special orders
  - Add prefix "H" to number (i.e., H1E)
 Options:
  - May be combined with a plate to make a pull plate
  - Other centers on special order
 Notes:
  - For sizes or finishes not listed in this catalog, contact Hager Customer Service for availability
  - Not suitable for back to back mounting

CTC Length	1E	1G	1J	1L
Inches	6	8	10	12
Millimeters	152	203	254	305



### 2

#### Rectangular Wrought Door Pull

- Certification: Meets ANSI A156.6 for J401 Pulls  
 Base: 3/8" x 1-1/4" (10 mm x 32 mm)  
 Projection: 2" (51 mm)  
 Clearance: 1-5/8" (41 mm)  
 Door Thickness: 1-3/4" (45 mm) - Standard  
 Materials: Aluminum, brass, bronze, stainless steel  
 Finishes: US3, US4, US10, US10B, US26, US26D, US28, US32, US32D  
 Fasteners: Two (2) 1/4-20 x 2-1/4" FPHMS with finish washers  
 Handicap:
  - 2-1/2" (64 mm) clearance available on special orders
  - Add prefix "H" to number (i.e., H2E)
 Options:
  - May be combined with a plate to make a pull plate
  - Other centers on special order
 Notes:
  - For sizes or finishes not listed in this catalog, contact Hager Customer Service for availability
  - Not suitable for back to back mounting

CTC Length	2E	2G	2J	2L
Inches	6	8	10	12
Millimeters	152	203	254	305



### 3

#### Round Wrought Door Pull

- Certification: Meets ANSI A156.6 for J401 Pulls  
 Base Diameter: 3/4" (19 mm)  
 Projection: 2-1/4" (57 mm)  
 Clearance: 1-1/2" (38 mm)  
 Door Thickness: 1-3/4" (45 mm) - Standard  
 Materials: Aluminum, brass, bronze, stainless steel  
 Finishes: US3, US4, US10, US10B, US26, US26D, US28, US32, US32D  
 Fasteners: Two (2) 1/4-20 x 2-1/4" FPHMS with finish washers  
 Handicap:
  - 2-1/2" (64 mm) clearance available on special orders
  - Add prefix "H" to number (i.e., H3E)
 Notes:
  - For sizes or finishes not listed in this catalog, contact Hager Customer Service for availability
  - May be combined with a plate to make a pull plate
  - Other centers on special order
  - If ordered with tempered glass, specify glass thickness and hole size
  - Back to back - see model 13

CTC Length	3E	3G	3J	3L
Inches	6	8	10	12
Millimeters	152	203	254	305



# PULLS



## 4 Round Wrought Door Pull

Certification: Meets ANSI A156.6 for J401 Pulls  
 Base Diameter: 1" (25 mm)  
 Projection: 2-3/4" (70 mm)  
 Clearance: 1-3/4" (45 mm)  
 Door Thickness: 1-3/4" (45 mm) - Standard  
 Materials: Aluminum, brass, bronze, stainless steel  
 Finishes: US3, US4, US10, US10B, US26, US26D, US28, US32, US32D  
 Fasteners: Two (2) 1/4-20 x 2-1/4" FPHMS with finish washers  
 Handicap:

Notes:

- 2-1/2" (64 mm) clearance available on special orders
- Add prefix "H" to number (i.e., H4E)
- For sizes or finishes not listed in this catalog, contact Hager Customer Service for availability
- May be combined with a plate to make a pull plate
- Other centers on special order
- If ordered with tempered glass, specify glass thickness and hole size
- Back to back - see model 13

CTC Length	4G	4H	4J	4L
Inches	8	9	10	12
Millimeters	203	229	254	305



## P4E Security Pull

Certification: Meets ANSI A156.6 for J401 Pulls  
 Base: 1" (25 mm) diameter  
 Projection: 2-1/4" (57 mm)  
 Clearance: 1-1/4" (32 mm)  
 CTC Length: 6" (152 mm)  
 Material: Stainless steel  
 Finish: US32D  
 Fasteners: Two (2) 3/8-16 x 1-1/4" "NYLOC" hex head cap screws  
 Notes:

- For metal doors
- Requires reinforcing plate with an access plate and Torx screws for door edge

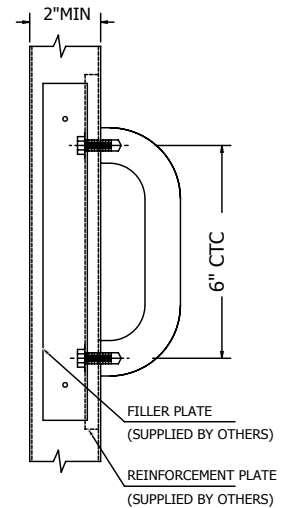

## T4E Security Pull

Certification: Meets ANSI A156.6 for J401 Pulls  
 Base: 1" (25 mm) diameter  
 Projection: 2-1/4" (57 mm)  
 Clearance: 1-1/4" (32 mm)  
 Door Thickness: 1-3/4" (45 mm) - Standard  
 CTC Length: 6" (152 mm)  
 Material: Stainless steel  
 Finish: US32D  
 Fasteners: Two (2) 1/4-20 x 2-1/4" FTXMS with finish washers





## PULLS



### 5D

#### Round Wrought Door Pull

- Certification: Meets ANSI A156.6 for J401 Pulls  
 Base Diameter: 5/8" (16 mm)  
 Projection: 2-1/8" (54 mm)  
 Clearance: 1-1/2" (38 mm)  
 CTC Length: 5-1/2" (140 mm)  
 Door Thickness: 1-3/4" (45 mm) - Standard  
 Materials: Aluminum, brass, bronze, stainless steel  
 Finishes: US3, US4, US10, US10B, US26, US26D, US28, US32, US32D  
 Fasteners: Two (2) 1/4-20 x 2-1/4" FPHMS with finish washers  
 Handicap:
  - 2-1/2" (64 mm) clearance available on special orders
  - Add prefix "H" to number (i.e., H5D)
 Notes:
  - For sizes or finishes not listed in this catalog, contact Hager Customer Service for availability
  - May be combined with a plate to make a pull plate
  - If ordered with tempered glass, specify glass thickness and hole size
  - Not suitable for back to back mounting



### 5N

#### Cast Pull

- Certification: Meets ANSI A156.6 for J401 Pulls  
 O/A Height: 6-1/8" (156 mm)  
 Base: 5/8" x 1-3/16" (16 mm x 30 mm)  
 Projection: 2" (51 mm)  
 Clearance: 1-1/2" (38 mm)  
 CTC Length: 5-1/2" (140 mm)  
 Door Thickness: 1-3/4" (45 mm) - Standard  
 Materials: Aluminum, brass, bronze, stainless steel  
 Finishes: US3, US4, US10, US10B, US26, US26D, US28, US32D  
 Fasteners: Two (2) 1/4-20 x 2-1/4" FPHMS with finish washers  
 Options: May be combined with a plate to make a pull plate  
 Notes: Not suitable for back to back mounting



### 6N

#### Cast Pull

- Certification: Meets ANSI A156.6 for J401 Pulls  
 O/A Height: 6-1/2" (165 mm)  
 Base Diameter: 1" (25 mm)  
 Projection: 1-7/8" (48 mm)  
 Clearance: 1-3/8" (35 mm)  
 CTC Length: 5-1/2" (140 mm)  
 Door Thickness: 1-3/4" (45 mm) - Standard  
 Materials: Aluminum, brass, bronze, stainless steel  
 Finishes: US3, US4, US10, US10B, US26, US26D, US28, US32D  
 Fasteners: Two (2) 1/4-20 x 2-1/4" FPHMS with finish washers  
 Options: May be combined with a plate to make a pull plate  
 Notes: Not suitable for back to back mounting

## PULLS



### 7N

#### Cast Pull

Certification: Meets ANSI A156.6 for J401 Pulls  
 O/A Height: 7-1/2" (190 mm)  
 Base Diameter: 2" (51 mm)  
 Projection: 1-7/8" (48 mm)  
 Clearance: 1-3/8" (35 mm)  
 CTC Length: 5-1/2" (140 mm)  
 Door Thickness: 1-3/4" (45 mm) - Standard  
 Materials: Aluminum, brass, bronze  
 Finishes: US3, US4, US10, US10B, US26, US26D, US28  
 Fasteners: Two (2) 1/4-20 x 2-1/4" FPHMS with finish washers  
 Options: May be combined with a plate to make a pull plate  
 Notes: Not suitable for back to back mounting



### 8N

#### Cast Pull

Certification: Meets ANSI A156.6 for J401 Pulls  
 O/A Height: 7-1/2" (190 mm)  
 Base Diameter: 2" (51 mm)  
 Projection: 1-7/8" (48 mm)  
 Clearance: 1-3/8" (35 mm)  
 CTC Length: 5-1/2" (140 mm)  
 Materials: Aluminum, brass, bronze  
 Finishes: US3, US4, US10, US10B, US26, US26D, US28  
 Fasteners: Six (6) #8 x 1" OPHWS  
 Notes: Not suitable for back to back mounting



### P8N

#### Cast Pull

Certification: Meets ANSI A156.6 for J401 Pulls  
 O/A Height: 8 - 3/4" (222 mm)  
 Base: 1-1/2" x 1-5/8" (38 mm x 41 mm)  
 Projection: 2-1/4" (57 mm)  
 Clearance: 1-9/16" (40 mm)  
 CTC Length: 7-3/4" (197 mm)  
 Materials: Brass  
 Finishes: US4, US26D  
 Fasteners: Two (2) 3/8-16 x 3/4" FPHMS  
 Options: Security Torx screws available  
 Notes: Not suitable for back to back mounting





## PULLS



### 9

#### Oval Wrought Door Pull

- Certification: Meets ANSI A156.6 for J401 Pulls  
 Base: 1/2" x 3/4" (13 mm x 19 mm)  
 Projection: 2" (51 mm)  
 Clearance: 1-1/2" (38 mm)  
 Door Thickness: 1-3/4" (45 mm) - Standard  
 Materials: Brass, bronze, stainless steel  
 Finishes: US3, US4, US10, US10B, US26, US26D, US32, US32D  
 Fasteners: Two (2) 1/4-20 x 2-1/4" FPHMS with finish washers  
 Handicap:
  - 2-1/2" (64 mm) clearance available on special orders
  - Add prefix "H" to number (i.e., H9E)
 Options:
  - May be combined with a plate to make a pull plate
  - Other centers on special order
 Notes:
  - For sizes or finishes not listed in this catalog, contact Hager Customer Service for availability
  - Not suitable for back to back mounting

CTC Length	9E	9G	9J	9L
Inches	6	8	10	12
Millimeters	152	203	254	305



### 10

#### Round Pull

- Certification: Meets ANSI A156.6 for J401 Pulls  
 Base Diameter: 1-1/4" (32 mm)  
 Projection: 3" (76 mm)  
 Clearance: 1-3/4" (45 mm)  
 Door Thickness: 1-3/4" (45 mm) - Standard  
 Materials: Aluminum, brass, bronze, stainless steel  
 Finishes: US3, US4, US10, US10B, US26, US26D, US28, US32, US32D  
 Fasteners: Two (2) 5/16-18 FPHMS with finish washers  
 Handicap:
  - 2-1/2" (64 mm) clearance available on special orders
  - Add prefix "H" to number (i.e., H10L)
 Options:
  - May be combined with a plate to make a pull plate
  - Other centers on special order
  - If ordered with tempered glass, specify glass thickness and hole size
 Notes:
  - For sizes or finishes not listed in this catalog, contact Hager Customer Service for availability
  - Back to back - see model 20

CTC Length	10L	10Q
Inches	12	18
Millimeters	305	457



### 11

#### Round Offset Pull

- Certification: Meets ANSI A156.6 for J402 Pulls  
 Base Diameter: 3/4" (19 mm)  
 Projection: 2-1/2" (64 mm)  
 Offset: 2-1/2" (64 mm); 90° Standard  
 Clearance: 1-3/4" (45 mm)  
 Door Thickness: 1-3/4" (45 mm) - Standard  
 Materials: Aluminum, brass, bronze, stainless steel  
 Finishes: US3, US4, US10, US10B, US26, US26D, US28, US32, US32D  
 Fasteners: Two (2) 5/16-18 x 2-1/4" FPHMS with finish washers  
 Handicap:
  - 2-1/2" (64 mm) clearance available on special orders
  - Add prefix "H" to number (i.e., H11E)
 Options:
  - For 45° offset, add prefix "X" to number (i.e., X11E)
  - Other centers available on special orders
  - If ordered with tempered glass, specify glass thickness and hole size
 Notes:
  - For sizes or finishes not listed in this catalog, contact Hager Customer Service for availability
  - Back to back - see model 21

CTC Length	11E	11G	11J	11L
Inches	6	8	10	12
Millimeters	152	203	254	305

## PULLS



### 12 Round Offset Pull

- Certification: Meets ANSI A156.6 for J402 Pulls
- Base Diameter: 1" (25 mm)
- Projection: 2-3/4" (70 mm)
- Offset: 3" (76 mm); 90° Standard
- Clearance: 1-3/4" (45 mm)
- Door Thickness: 1-3/4" (45 mm) - Standard
- Materials: Aluminum, brass, bronze, stainless steel
- Finishes: US3, US4, US10, US10B, US26, US26D, US28, US32, US32D
- Fasteners: Two (2) 5/16-18 x 2-1/4" FPHMS with finish washers
- Handicap:
  - 2-1/2" (64 mm) clearance available on special orders
  - Add prefix "H" to number (i.e., H12G)
- Options:
  - For 45° offset, add prefix "X" to number (i.e., X12G)
  - Other centers available on special orders
  - If ordered with tempered glass, specify glass thickness and hole size
- Notes: For sizes or finishes not listed in this catalog, contact Hager Customer Service for availability

CTC Length	12G	12J	12L
Inches	8	10	12
Millimeters	203	254	305



### 13 Round Wrought Door Push/Pull Set

- Certification: Meets ANSI A156.6 for J401 Pulls
- Base Diameter: 3/4" (19 mm)
- Projection: 2-1/4" (57 mm)
- Clearance: 1-1/2" (38 mm)
- Door Thickness: 1-3/4" (45 mm) - 2-1/8" (54 mm) Standard
- Materials: Aluminum, brass, bronze, stainless steel
- Finishes: US3, US4, US10, US10B, US26, US26D, US28, US32, US32D
- Notes:
  - Type 7 mounting - Standard
  - Consists of two (2) pulls back to back
  - For sizes or finishes not listed in this catalog, contact Hager Customer Service for availability
  - Supplied with two (2) 1/4" dia. threaded studs, spanner collar, and spanner wrench

CTC Length	13E	13G	13J	13L
Inches	6	8	10	12
Millimeters	152	203	254	305



### 14 Round Wrought Door Push/Pull Set

- Certification: Meets ANSI A156.6 for J401 Pulls
- Base Diameter: 1" (25 mm)
- Projection: 2-3/4" (70 mm)
- Clearance: 1-3/4" (45 mm)
- Door Thickness: 1-3/4" (45 mm) - 2-1/8" (54 mm) Standard
- Materials: Aluminum, brass, bronze, stainless steel
- Finishes: US3, US4, US10, US10B, US26, US26D, US28, US32, US32D
- Notes:
  - Type 7 mounting - Standard
  - Consists of two (2) pulls back to back
  - For sizes or finishes not listed in this catalog, contact Hager Customer Service for availability
  - Supplied with two (2) 1/4" dia. threaded studs, spanner collar, and spanner wrench

CTC Length	14G	14H	14J	14L
Inches	8	9	10	12
Millimeters	203	229	254	305





## PULLS



### 19N

#### Cast Pull

Certification: Meets ANSI A156.6 for J401 Pulls  
 O/A Height: 9" (229 mm)  
 Base Diameter: 1-1/2" (38 mm)  
 Projection: 3-1/8" (79 mm)  
 CTC Length: 6-3/16" (132 mm)  
 Materials: Brass  
 Finishes: US3, US10, US10B, US26, US26D  
 Fasteners: Four (4) #8 x 1" OPHWS  
 Notes: Suitable for back to back mounting with sex nuts by special quotation  
 Clearance: 1-11/16" (43 mm)



### 20

#### Round Push/Pull Set

Certification: Meets ANSI A156.6 for J401 Pulls  
 Base Diameter: 1-1/4" (32 mm)  
 Projection: 3" (76 mm)  
 Clearance: 1-3/4" (45 mm)  
 Door Thickness: 1-3/4" (45 mm) - 2-1/8" (54 mm) Standard  
 Materials: Brass, bronze, stainless steel  
 Finishes: US3, US4, US10, US10B, US26, US26D, US28, US32, US32D  
 Notes:

CTC Length	20L	20Q
Inches	12	18
Millimeters	305	457

- Type 7 mounting - Standard
- Consists of two (2) pulls back to back
- For sizes or finishes not listed in this catalog, contact Hager Customer Service for availability
- Supplied with two (2) 5/16" dia. threaded studs, spanner collar, and spanner wrench



### 20N

#### Cast Pull

Certification: Meets ANSI A156.6 for J401 Pulls  
 O/A Height: 9" (229 mm)  
 Base Diameter: 1-1/2" (38 mm)  
 Projection: 3-1/8" (79 mm)  
 CTC Length: 5-7/32" (132.5 mm)  
 Door Thickness: 1-3/4" - Standard  
 Material: Brass  
 Finishes: US3, US10, US10B, US26, US26D  
 Fasteners: Two (2) 1/4 - 20 x 2-3/16" undercut FPHMS with finish washers  
 Clearance: 1-11/16" (43 mm)



### 21

#### Round Offset Push/Pull Set

Certification: Meets ANSI A156.6 for J402 Pulls  
 Base Diameter: 3/4" (19 mm)  
 Projection: 2-1/2" (64 mm)  
 Clearance: 1-3/4" (45 mm)  
 Offset: 2-1/2" (64); 90° - Standard  
 Door Thickness: 1-3/4" (45 mm) - 2-1/8" (54 mm) Standard  
 Materials: Aluminum, brass, bronze, stainless steel  
 Finishes: US3, US4, US10, US10B, US26, US26D, US28, US32, US32D  
 Notes:

CTC Length	21E	21G	21J	21L
Inches	6	8	10	12
Millimeters	152	203	254	305

- Type 7 mounting - Standard
- Consists of two (2) pulls back to back
- Available with 45 degree offset
- For sizes or finishes not listed in this catalog, contact Hager Customer Service for availability
- Supplied with two (2) 1/4" dia. threaded studs, spanner collar, and spanner wrench

## PULLS



### 22

#### Round Offset Push/Pull Set

Certification: Meets ANSI A156.6 for J402 Pulls  
 Base Diameter: 1" (25 mm)  
 Projection: 2-3/4" (70 mm)  
 Clearance: 1-3/4" (45 mm)  
 Door Thickness: 1-3/4" (45 mm) - 2-1/18" (54 mm) Standard  
 Offset: 3" (76 mm); 90° standard  
 Materials: Aluminum, brass, bronze, stainless steel  
 Finishes: US3, US4, US10, US10B, US26, US26D, US28, US32, US32D  
 Notes:

- Type 7 mounting - Standard
- Consists of two (2) pulls back to back
- Available with 45 degree offset
- For sizes or finishes not listed in this catalog, contact Hager Customer Service for availability
- Supplied with two (2) 1/4" dia. threaded studs, spanner collar, and spanner wrench

CTC Length	22G	22J	22L
Inches	8	10	12
Millimeters	203	254	305



### 23Q

#### Round Offset Pull

Certification: Meets ANSI A156.6 for J402 Offset Pulls  
 Base Diameter: 1-1/4" (32 mm)  
 Projection: 3" (76 mm)  
 Clearance: 1-3/4" (45 mm)  
 Offset: 3-3/4" (96 mm); 90° Standard  
 Door Thickness: 1-3/4" (45 mm) - Standard  
 CTC Length: 18" (457 mm)  
 Materials: Aluminum, brass, bronze, stainless steel  
 Finishes: US3, US4, US10, US10B, US26, US26D, US28, US32, US32D  
 Fasteners: 5/16-18 x 2-1/4" FPHMS with finish washers  
 Handicap:

- 2-1/2" (64 mm) clearance available on special orders
- Add prefix "H" to number (i.e., H23Q)

Options:

For 45° offset, substitute "X" for first digit (i.e., X23Q)

Notes:

- If ordered with tempered glass, specify glass thickness and hole size
- For sizes or finishes not listed in this catalog, contact Hager Customer Service for availability



### 24Q

#### Round Offset Push/Pull Set

Certification: Meets ANSI A156.6 for J402 Offset Pulls  
 Base Diameter: 1-1/4" (32 mm)  
 Projection: 3" (76 mm)  
 Clearance: 1-3/4" (45 mm)  
 Offset: 3-3/4" (95 mm); 90° standard  
 Door Thickness: 1-3/4" (45 mm) - 2-1/18" (54 mm) Standard  
 CTC Length: 18" (457 mm)  
 Materials: Aluminum, brass, bronze, stainless steel  
 Finishes: US3, US4, US10, US10B, US26, US26D, US28, US32, US32D  
 Notes:

- Type 7 mounting - Standard
- Consists of two (2) pulls back to back
- Available with 45 degree offset
- For sizes or finishes not listed in this catalog, contact Hager Customer Service for availability
- Supplied with two (2) 5/16" dia. threaded studs, spanner collar, and spanner wrench





## PULLS

### 910P | 910B

#### Offset Mounting Vertical Pull

Pull Diameter:	1-1/4" (32 mm)
O/A Length:	36" (914 mm), 72" (1829 mm)
CTC Lengths:	20" (508 mm), 56" (1422 mm)
Materials:	Aluminum, brass, bronze, stainless steel tubing
Finishes:	US3, US4, US10, US10B, US15A, US26, US26D, US28, US32D
Fasteners:	Two (2) 3/8-16 FPHMS with finish washers
Notes:	<ul style="list-style-type: none"> <li>• 910B is same as 910P with fasteners for back to back mounting</li> <li>• For sizes or finishes not listed in this catalog, contact Hager Customer Service for availability</li> </ul>
Clearance:	1-1/2" (38 mm)
Projection:	2-3/4" (70 mm)
Offset:	1-5/8" (41 mm)



### 915P | 915B

#### Straight Mounting Vertical Pull

Pull Diameter:	1-1/4" (32 mm)
O/A Length:	36" (914 mm), 72" (1829 mm)
CTC Lengths:	20" (508 mm), 56" (1422 mm)
Materials:	Aluminum, brass, bronze, stainless steel tubing
Finishes:	US3, US4, US10, US10B, US15A, US26, US26D, US28, US32D
Fasteners:	Two (2) 3/8-16 FPHMS w/ finish washers
Notes:	<ul style="list-style-type: none"> <li>• 915B is same as 915P with fasteners for back to back mounting</li> <li>• For sizes or finishes not listed in this catalog, contact Hager Customer Service for availability</li> </ul>
36" and 20"	
Clearance:	2" (51 mm)
Projection:	3-1/4" (83 mm)
72" and 56"	
Clearance:	1-1/2" (38 mm)
Projection:	2-3/4" (70 mm)





## PULLS



### 920P | 920B

#### C-Shaped Pull

Base Diameter:	1" (25 mm)
Clearance:	1-3/4" (45 mm)
Projection:	2-1/4" (57 mm)
CTC Length:	8-1/2" (217 mm)
Materials:	Aluminum, brass, bronze, stainless steel
Finishes:	US3, US4, US10, US10B, US15A, US26, US26D, US28, US32D
Fasteners:	Two (2) 3/8-16 FPHMS with finish washers
Notes:	<ul style="list-style-type: none"> <li>• 920B is pair of 920P with fasteners for back to back mounting</li> <li>• For sizes or finishes not listed in this catalog, contact Hager Customer Service for availability</li> </ul>



### 921P | 921B

#### C-Shaped Pull

Clearance:	1-1/2" (38 mm)
Offset:	8-1/2" (216 mm)
Projection:	2-1/8" (54 mm)
CTC Length:	17-1/2" (446 mm)
Materials:	Brass, bronze, stainless steel
Finishes:	US3, US4, US10, US10B, US15A, US26, US26D, US32D
Fasteners:	Two (2) 3/8-16 FPHMS with finish washers
Notes:	<ul style="list-style-type: none"> <li>• 921B is pair of 921P with fasteners for back to back mounting</li> <li>• For sizes or finishes not listed in this catalog, contact Hager Customer Service for availability</li> </ul>



### 922P | 922B

#### C-Shaped Pull - Continuous

Pull Diameter:	1" (25 mm)
Projection:	2-1/2" (64 mm)
CTC Lengths:	10" (254 mm), 12" (305 mm)
Clearance:	1-1/2" (38 mm)
Materials:	Aluminum, brass, bronze, stainless steel
Finishes:	US3, US4, US10, US10B, US15A, US26, US26D, US28, US32D
Fasteners:	Two (2) 3/8-16 FPHMS with finish washers
Notes:	<ul style="list-style-type: none"> <li>• 922B is pair of 922P with fasteners for back to back mounting</li> <li>• For sizes or finishes not listed in this catalog, contact Hager Customer Service for availability</li> </ul>



### 923P | 923B

#### C-Shaped Pull - Flanged

Pull Diameter:	1" (25 mm)
Projection:	2-3/4" (70 mm)
CTC Lengths:	10" (254 mm), 12" (305 mm)
Clearance:	1-3/4" (44 mm)
Base Diameter:	3/4" (19 mm)
Materials:	Aluminum, brass, bronze, stainless steel
Finishes:	US3, US4, US10, US10B, US15A, US26, US26D, US28, US32D
Fasteners:	Two (2) 3/8-16 FPHMS with finish washers
Notes:	<ul style="list-style-type: none"> <li>• 923B is pair of 923P with fasteners for back to back mounting</li> <li>• For sizes or finishes not listed in this catalog, contact Hager Customer Service for availability</li> </ul>





## PULLS



### 924P | 924B C-Shaped Pull

Projection: 2-1/2" (64 mm)  
 CTC Length: 14" (356 mm)  
 Clearance: 1-1/2" (38 mm)  
 Offset: 6-1/2" (165 mm)  
 Materials: Brass, bronze, stainless steel  
 Finishes: US3, US4, US10B, US15A, US26, US26D, US32D  
 Fasteners: Two (2) 3/8-16 FPHMS with finish washers  
 Notes:
 

- 924B is pair of 924P with fasteners for back to back mounting
- For sizes or finishes not listed in this catalog, contact Hager Customer Service for availability



### 925P | 925B C-Shaped Pull

Pull Diameter: 1-1/4" (32 mm)  
 CTC Lengths: 6-1/2" (165 mm), 8-1/2" (217 mm), 12-1/2" (318 mm)  
 Materials: Aluminum, brass, bronze, stainless steel  
 Finishes: US3, US4, US10B, US15A, US26, US26D, US28, US32D  
 Fasteners: Two (2) 3/8-16 FPHMS with finish washers  
 Notes:
 

- 925B is pair of 925P with fasteners for back to back mounting
- For sizes or finishes not listed in this catalog, contact Hager Customer Service for availability



### 926P | 926B Curved Pull

Base Diameter: 1-1/4" (32 mm)  
 Projection: 3" (76 mm)  
 Clearance: 1-13/16" (46 mm)  
 Offset: 5-9/32" (134 mm)  
 Pull Diameter: 1-3/16" (30 mm)  
 CTC Length: 12" (305 mm)  
 Materials: Brass, bronze  
 Finishes: US3, US4, US10, US10B  
 Fasteners: Two (2) 3/8-16 FPHMS with finish washers  
 Notes:
 

- 926B is pair of 926P with fasteners for back to back mounting
- For sizes or finishes not listed in this catalog, contact Hager Customer Service for availability



### 930P | 930B 90° Pull

Projection: 3" (76 mm)  
 Clearance: 1-3/4" (45 mm)  
 CTC Lengths: 14-5/32" - 16-31/32" (360 mm - 431 mm)  
 Materials: Aluminum, brass, bronze, stainless steel  
 Finishes: US3, US4, US10B, US15A, US26, US26D, US28, US32D  
 Fasteners: Two (2) 3/8-16 FPHMS with finish washers  
 Notes:
 

- 930B is pair of 930P with fasteners for back to back mounting
- For sizes or finishes not listed in this catalog, contact Hager Customer Service for availability

## PULLS



### 932P | 932B S-Shaped Pull

Projection: 3" (76 mm)  
 Clearance: 2" (51 mm)  
 Pull Diameter: 1" (25 mm)  
 Fasteners: Two (2) 3/8-16 FPHMS w/ finish washers  
 CTC Length: 30" (762 mm)  
 Materials: Aluminum, brass, bronze, stainless steel  
 Finishes: US3, US4, US10B, US15A, US26, US26D, US28, US32D  
 Fasteners: Two (2) 3/8-16 FPHMS with finish washers  
 Notes:
 

- 932B is pair of 932P with fasteners for back to back mounting
- Specify handing when ordering
- For sizes or finishes not listed in this catalog, contact Hager Customer Service for availability



### 933P | 933B Colonial Style Pull

Projection: 2-3/16" (56 mm)  
 Clearance: 1-3/16" (30 mm)  
 Pull Diameter: 1" (25 mm)  
 Base Diameter: 15/16" (24 mm)  
 CTC Length: 6" (152 mm)  
 Materials: Brass and bronze  
 Finishes: US3, US4, US10B, US26  
 Fasteners: Two (2) 3/8-16 FPHMS with finish washers  
 Notes: 933B is pair of 933P with fasteners for back to back mounting



### 934P | 934B Offset Pull

Projection: 3-1/8" (80 mm)  
 Clearance: 1-7/8" (48 mm)  
 Pull Diameter: 1-1/4" (32 mm)  
 Base Diameter: 1" (25 mm)  
 CTC Lengths: 12" (305 mm), 16" (406 mm), 18" (457 mm)  
 Materials: Aluminum, brass, bronze, stainless steel  
 Finishes: US3, US4, US10B, US15A, US26, US26D, US28, US32D  
 Fasteners: Two (2) 3/8-16 FPHMS with finish washers  
 Notes: 934B is pair of 934P with fasteners for back to back mounting



### 960P | 960B Square Tip Pull

O/A Height: 16" (406 mm)  
 Base Diameter: 1-1/4" (32 mm)  
 Pull Diameter: 1" (25 mm)  
 Clearance: 1-3/4" (45 mm)  
 Projection: 3-1/4" (83 mm)  
 CTC Length: 12" (305 mm)  
 Materials: Brass, bronze  
 Finishes: US3, US4, US10B, US15A, US26, US26D  
 Fasteners: Two (2) 3/8-16 FPHMS w/ finish washers  
 Notes:
 

- 960B is pair of 960P with fasteners for back to back mounting
- For sizes or finishes not listed in this catalog, contact Hager Customer Service for availability





## PULLS



### 961P | 961B

#### Steeple Tip Pull

O/A Height: 16-5/16" (414 mm)  
 Base Diameter: 2" (51 mm)  
 Pull Diameter: 1" (25 mm)  
 Clearance: 1-3/4" (45 mm)  
 Projection: 3" (76 mm)  
 CTC Length: 12" (305 mm)  
 Materials: Brass, bronze  
 Finishes: US3, US4, US10B, US15A, US26, US26D  
 Fasteners: Two (2) 3/8-16 FPHMS with finish washers  
 Notes:
 

- 961B is pair of 961P with fasteners for back to back mounting
- For sizes or finishes not listed in this catalog, contact Hager Customer Service for availability



### 962P

#### Acorn Tip Pull

O/A Height: 16-5/16" (414 mm)  
 Base Diameter: 2" (51 mm)  
 Pull Diameter: 1" (25 mm)  
 Projection: 3" (76 mm)  
 Clearance: 1-7/8" (48 mm)  
 CTC Length: 12" (305 mm)  
 Materials: Brass, bronze  
 Finishes: US3, US4, US10B, US15A, US26, US26D  
 Fasteners: Two (2) 3/8-16 FPHMS with finish washers  
 Notes: For sizes or finishes not listed in this catalog, contact Hager Customer Service for availability



### 963P

#### Acorn Pull - Offset

O/A Height: 16-5/16" (414 mm)  
 Pull Diameter: 1" (25 mm)  
 Projection: 2-3/4" (70 mm)  
 CTC Lengths: 12" (304 mm), 16" (406 mm), 18" (457 mm), 24" (610 mm), 30" (762 mm)  
 Materials: Cast brass, bronze  
 Finishes: US3, US4, US10B, US15A, US26, US26D  
 Fasteners: Two (2) 3/8-16 FPHMS with finish washers  
 Notes: For sizes or finishes not listed in this catalog, contact Hager Customer Service for availability



### 967P

#### Curved Pull

O/A Height: 20-1/2" (520 mm)  
 Projection: 5-9/16" (141 mm)  
 Clearance: 3-9/16" (90 mm)  
 CTC Length: 16" (406 mm)  
 Materials: Brass, bronze  
 Finishes: US3, US4, US10B, US15A, US26, US26D  
 Fasteners: Two (2) 3/8-16 FPHMS with finish washers  
 Notes: For sizes or finishes not listed in this catalog, contact Hager Customer Service for availability

## PULLS



### 970P

#### Custom Push/Pull Set

Base Diameter: 1" (25 mm)  
 Pull Projection: 3" (76 mm)  
 Pull Clearance: 2" (51 mm)  
 CTC Length: 13-1/4" (337 mm)  
 Push Projection: 2-3/4" (70 mm)  
 Push Clearance: 1-3/4" (45 mm)  
 CTC Length: 34" (864 mm) or to suit door dimension  
 Materials: Brass, bronze, stainless steel  
 Finishes: US3, US4, US10, US10B, US15A, US26, US26D, US32D  
 Fasteners: 3/8 x 16 Type 3 mounting, concealed cone with 3/8 x 16 Type 2 thru bolts and finish washer

#### Notes:

- Pull or push bar can be ordered separately by quotation only
- Push bar radius can be custom made so the radius points in the downward direction
- For sizes or finishes not listed in this catalog, contact Hager Customer Service for availability



### 974P | 974B

#### Door Pull

Projection: 2-1/2" (64 mm)  
 CTC Length: 12" (304 mm), 18" (457 mm), 24" (610 mm), 30" (762 mm), 36" (914 mm), 48" (1219 mm)

Materials: Brass, bronze, stainless steel  
 Finishes: US3, US4, US10B, US26, US26D, US32D  
 Fasteners: Two (2) 3/8-16 FPHMS with finish washers

#### Notes:

- 974B is pair of 974P with fasteners for back to back mounting
- For sizes or finishes not listed in this catalog, contact Hager Customer Service for availability



### 975P | 975B

#### Vertical Pull

Projection: 2-3/4" (70 mm)  
 O/A Length: 36" (914 mm), 72" (1829 mm)  
 CTC Length: 20" (508 mm), 56" (1422 mm)  
 Pull Diameter: 1" (25 mm)

Materials: Brass, bronze, stainless steel  
 Finishes: US3, US4, US10, US10B, US15A, US26, US26D, US32D  
 Fasteners: Two (2) 3/8-16 FPHMS with finish washers

#### Notes:

- 975B is pair of 975P with fasteners for back to back mounting
- For sizes or finishes not listed in this catalog, contact Hager Customer Service for availability





## PULLS



### 976P | 976B

#### Door Pull - Offset

O/A Height: 29-1/2" (750 mm)  
 Base Diameter: 1-1/4" (32 mm)  
 Pull Diameter: 1-1/4" (32 mm)  
 Projection: 5-3/8" (137 mm)  
 Clearance: 4-1/8" (105 mm)  
 Offset: 1-3/4" (45 mm)  
 CTC Length: 19-13/16" (503 mm)  
 Materials: Stainless steel  
 Finish: US32D  
 Fasteners: Two (2) 3/8-16 FPHMS with finish washers  
 Notes:

- 976B is pair of 976P with fasteners for back to back mounting
- For sizes or finishes not listed in this catalog, contact Hager Customer Service for availability



### 980P | 980B

#### Segment Shape - Straight

CTC Length: 9" (229 mm), 12" (305 mm), 18" (457 mm), 24" (610 mm)  
 Materials: Brass, bronze, stainless steel  
 Finishes: US3, US4, US10B, US15A, US26, US26D, US32D  
 Fasteners: Two (2) 3/8-16 FPHMS with finish washers  
 Notes:

- 980B is pair of 980P with fasteners for back to back mounting
- For sizes or finishes not listed in this catalog, contact Hager Customer Service for availability



### 981P | 981B

#### Segment Shape - Offset

Projection: 2-3/8" (60 mm)  
 CTC Length: 9" (229 mm), 12" (305 mm), 18" (457 mm), 24" (610 mm)  
 Materials: Brass, bronze, stainless steel  
 Finishes: US3, US4, US10B, US15A, US26, US26D, US32D  
 Fasteners: Two (2) 3/8-16 FPHMS with finish washers  
 Notes:

- 981B is pair of 981P with fasteners for back to back mounting
- For sizes or finishes not listed in this catalog, contact Hager Customer Service for availability



### 982P | 982B

#### Straight Pull

Base Diameter: 1-5/16" (33 mm)  
 Projection: 3-1/8" (79 mm)  
 Clearance: 1-13/16" (46 mm)  
 CTC Length: 20" (508 mm)  
 Materials: Brass, bronze, stainless steel  
 Finishes: US3, US4, US10B, US15A, US26, US26D, US32D  
 Fasteners: Two (2) 3/8-16 FPHMS with finish washers  
 Notes:

- 982B is pair of 982P with fasteners for back to back mounting
- For sizes or finishes not listed in this catalog, contact Hager Customer Service for availability

## PULLS



### 983P | 983B

#### Curved Pull

O/A Height:	21-1/4" (540 mm)
Base Diameter:	1-1/4" (32 mm)
Projection:	3-1/8" (79 mm)
Clearance:	1-7/8" (48 mm)
CTC Length:	20" (508 mm)
Materials:	Brass, bronze, stainless steel
Finishes:	US3, US4, US10B, US15A, US26, US26D, US32D
Fasteners:	Two (2) 3/8-16 FPHMS with finish washers
Notes:	<ul style="list-style-type: none"> <li>• 983B is pair of 983P with fasteners for back to back mounting</li> <li>• Specify handing when ordering</li> <li>• For sizes or finishes not listed in this catalog, contact Hager Customer Service for availability</li> </ul>



### 984P | 984B

#### Curved Pull

Projection:	3" (76 mm)
CTC Lengths:	12" (305 mm), 20" (508 mm)
Materials:	Brass, bronze, stainless steel
Finishes:	US3, US4, US10B, US15A, US26, US32, US32D
Fasteners:	Two (2) 3/8-16 FPHMS with finish washers
Notes:	<ul style="list-style-type: none"> <li>• 984B is pair of 984P with fasteners for back to back mounting</li> <li>• For sizes or finishes not listed in this catalog, contact Hager Customer Service for availability</li> </ul>



### 985P | 985B

#### Curved Pull

O/A Height:	14" (356 mm)
Base Diameter:	2" (51 mm)
Projection:	3" (76 mm)
Clearance:	1-9/16" (40 mm)
Offset:	1-5/8" (41 mm)
CTC Length:	12" (305 mm)
Materials:	Brass, bronze, stainless steel
Finishes:	US3, US4, US10B, US15A, US26, US26D, US32D
Fasteners:	Two (2) 3/8-16 FPHMS with finish washers
Notes:	<ul style="list-style-type: none"> <li>• 985B is pair of 985P with fasteners for back to back mounting</li> <li>• For sizes or finishes not listed in this catalog, contact Hager Customer Service for availability</li> </ul>



### 986P | 986B

#### Curved Pull

O/A Height:	22" (559 mm)
Pull Diameter:	1-1/4" (32 mm)
Base Diameter:	2" (51 mm)
Projection:	3-7/8" (99 mm)
Clearance:	2-5/8" (67 mm)
Offset:	3" (76 mm)
CTC Length:	20" (508 mm)
Materials:	Brass, bronze, stainless steel
Finishes:	US3, US4, US10B, US15A, US26, US26D, US32
Fasteners:	Two (2) 3/8-16 FPHMS with finish washers
Notes:	<ul style="list-style-type: none"> <li>• 986B is pair of 986P with fasteners for back to back mounting</li> <li>• For sizes or finishes not listed in this catalog, contact Hager Customer Service for availability</li> </ul>





## PULLS



### 987P | 987B Double Curved Pull

Base Diameter: 1-1/4" (32 mm)

Projection: 3" (76 mm)

Clearance: 2" (51 mm)

CTC Length: 20" (508 mm)

Materials: Brass, bronze, stainless steel

Finishes: US3, US4, US10B, US15A, US26, US26D, US32D

Fasteners: Two (2) 3/8-16 FPHMS with finish washers

Notes:

- 987B is pair of 987P with fasteners for back to back mounting
- For sizes or finishes not listed in this catalog, contact Hager Customer Service for availability



### 988P | 988B Offset Pull

Projection: 3" (76 mm)

CTC Length: 24" (610 mm)

Materials: Brass, bronze, stainless steel

Finishes: US3, US26, US32D

Fasteners: Two (2) 3/8-16 FPHMS with finish washers

Notes:

- 988B is pair of 988P with fasteners for back to back mounting
- For sizes or finishes not listed in this catalog, contact Hager Customer Service for availability



### 990P | 990B 18° Pull

Pull Diameter: 1" (25 mm)

Projection: 2-3/4" (70 mm)

Clearance: 1-3/4" (45 mm)

CTC Length: 24" (610 mm)

Materials: Brass, bronze, stainless steel

Finishes: US3, US4, US10B, US15A, US26, US26D, US32D

Fasteners: Two (2) 3/8-16 FPHMS with finish washers

Notes:

- 990B is pair of 990P with fasteners for back to back mounting
- Specify handing when ordering
- For sizes or finishes not listed in this catalog, contact Hager Customer Service for availability



## FLUSH CUP PULLS



### 15C

#### Heavy Duty Flush Cup Pull

Certification: Meets ANSI A156.6 for J403 Pulls  
 Description: Cup welded to face plate  
 Face: 3-1/2" x 5" (89 mm x 127 mm)  
 Projection: 1/8" (3.2 mm)  
 Opening: 1-3/4" x 3-1/16" (44 mm x 78 mm)  
 Cup Clearance: 3/4" (19 mm)  
 Materials: Stainless steel  
 Finishes: US32D  
 Fasteners: Four (4) #6 x 5/8" OPHWS



### 15N

#### Flush Cup Pull

Certification: Meets ANSI A156.6 for J403 Pulls  
 Description: Cup welded to face plate  
 Face: 3-1/2" x 5" (89 mm x 127 mm)  
 Projection: 1/8" (3.2 mm)  
 Opening: 1-3/4" x 3-1/16" (44 mm x 78 mm)  
 Cup Clearance: 3/4" (19 mm)  
 Materials: Aluminum, brass, bronze, stainless steel  
 Finishes: US3, US4, US10, US10B, US26, US26D, US28, US32D  
 Fasteners: Four (4) #6 x 5/8" OPHWS



### 15P

#### Heavy Duty Security Flush Cup Pull

Certification: Meets ANSI A156.6 for J403 Pulls  
 Description: Cup welded to face plate and welded studs for security torx thru-bolt mounting  
 Face: 3-1/2" x 5" (89 mm x 127 mm)  
 Projection: 1/8" (3.2 mm)  
 Opening: 1-3/4" x 3-1/16" (44 mm x 78 mm)  
 Cup Clearance: 3/4" (19 mm)  
 Materials: Stainless steel  
 Finishes: US32D  
 Fasteners: Two (2) 6-32 x 1-1/2" FPHMS (Security Torx)  
 Notes: For use on 1-3/4" (44 mm) doors



### 15S

#### Light Duty Flush Cup Pull

Certification: Meets ANSI A156.6 for J403 Pulls  
 Description: Concealed mounting by screws within the recessed cup (similar to 16N or 17N)  
 Face: 3-1/2" x 5" (89 mm x 127 mm)  
 Projection: 1/8" (3.2 mm)  
 Opening: 1-3/4" x 3-1/16" (44 mm x 78 mm)  
 Cup Clearance: 3/4" (19 mm)  
 Materials: Aluminum, brass, bronze, stainless steel  
 Finishes: US3, US4, US10, US10B, US26, US26D, US28, US32D  
 Fasteners: Two (2) #6 x 5/8" PPHWS  
 Notes: Fasteners concealed in cup





## FLUSH CUP PULLS



### 16N

#### Light Duty Flush Cup Pull

Certification: Meets ANSI A156.6 for J403 Pulls  
 Face: 1-15/16" x 3" (49 mm x 76 mm)  
 Projection: 1/16" (1.5 mm)  
 Opening: 27/32" x 2-3/8" (22 mm x 60 mm)  
 Cup Clearance: 5/8" (16 mm)  
 Materials: Brass  
 Finishes: US3, US4, US10, US10B, US26, US26D  
 Fasteners: Two (2) #8 x 3/4" OPHWS  
 Notes: Fasteners concealed in cup



### 16R

#### Finger Pull Plate

Certification: Meets ANSI A156.6 for combination J301 Pull Plate and J403 Pulls  
 Face: 4" x 16" (102 mm x 406 mm)  
 Projection: .050" (1.3 mm)  
 Opening: 1-3/4" x 3-1/16" (44 x 78 mm)  
 Cup Clearance: 13/16" (21 mm)  
 Materials: Aluminum, brass, bronze, stainless steel  
 Finishes: US3, US4, US10, US10B, US26, US26D, US28, US32, US32D  
 Fasteners: Ten (10) #6 x 5/8" OPHWS



### 17N

#### Light Duty Flush Cup Pull

Certification: Meets ANSI A156.6 for J403 Pulls  
 Face: 2-1/2" x 3-31/32" (64 mm x 101 mm)  
 Projection: 3/32" (2.4 mm)  
 Opening: 1-11/32" x 3-13/32" (34 mm x 87 mm)  
 Cup Clearance: 5/8" (16 mm)  
 Materials: Brass  
 Finishes: US3, US4, US10, US10B, US26, US26D  
 Fasteners: Two (2) #8 x 13/16" OPHWS  
 Notes: Fasteners concealed in cup



### 25B

#### Security Flush Pull Set

Certification: Meets ANSI A156.6 for J403 Pulls  
 Face: 3-1/2" x 5" (89 mm x 127 mm)  
 Opening: 1-3/4" x 3-1/16" (45 mm x 78 mm)  
 Projection: 3/16" (5 mm)  
 Cup Clearance: 3/4" (19 mm)  
 Door Thickness: 1-3/4" (45 mm) - Standard  
 Materials: Stainless steel  
 Finishes: US32D  
 Fasteners: Two (2) 6-32 x 1-1/2" FPHMS (Security Torx)  
 Notes: Security pull thru-bolted to a 15P pull

## FLUSH CUP PULLS



### 25C

#### Heavy Duty Flush Pull Set

Certification: Meets ANSI A156.6 for J403 Pulls  
 Face: 3-1/2" x 5" (89 mm x 127 mm)  
 Opening: 1-3/4" x 3-1/16" (45 mm x 78 mm)  
 Projection: 1/8" (3 mm)  
 Cup Clearance: 3/4" (19 mm)  
 Door Thickness: 1-3/4" (45 mm) - Standard  
 Materials: Stainless steel  
 Finishes: US32D  
 Fasteners: Two (2) 6-32 OPHMS sex nuts and bolts  
 Notes: Consists of two (2) 15C pulls mounted back to back



### 25N

#### Flush Pull Set

Certification: Meets ANSI A156.6 for J403 Pulls  
 Face: 3-1/2" x 5" (89 mm x 127 mm)  
 Opening: 1-3/4" x 3-1/16" (45 mm x 78 mm)  
 Projection: 1/8" (3 mm)  
 Cup clearance: 3/4" (19 mm)  
 Door Thickness: 1-3/4" (45 mm) - Standard  
 Materials: Aluminum, brass, bronze, stainless steel  
 Finishes: US3, US4, US10, US10B, US26, US26D, US28, US32D  
 Fasteners: Two (2) 6-32 OPHMS sex nuts and bolts  
 Notes: Consists of two (2) 15N pulls mounted back to back



### 25P

#### Security Finger Push/Pull Plate Set

Certification: Meets ANSI A156.6 for combination J301 Push Plate and J403 Flush Pull  
 Face: 4" x 16" (102 mm x 406 mm)  
 Projection: 1/8" (3.2 mm)  
 Opening: 1-3/4" x 3-1/16" (44 mm x 78 mm)  
 Cup Clearance: 13/16" (21 mm)  
 Materials: Stainless steel  
 Finishes: US32D  
 Fasteners: Six (6) 8-32 x 3/4" FPHMS (Security Torx) with sex nuts and bolts  
 Notes: Consists of a 15 pull cup welded to a 100T push plate (Mounted in back to back fashion)



### 26N

#### Security Finger Pull

Certification: Meets ANSI A156.6 for J403 Pulls  
 Face: 4" x 5" (102 mm x 127 mm)  
 Projection: 1/8" (3.2 mm)  
 Opening: 1-5/8" x 3" (41 mm x 76 mm)  
 Cup Clearance: 13/16" (21 mm)  
 Materials: Brass, stainless steel  
 Finishes: US4, US26D, US32D  
 Fasteners: Four (4) 1/4-20 x 3/4" Undercut FPHMS (Security Torx)  
 Notes: Cup welded to face





## FLUSH CUP PULLS



### 27N

#### Security Flush Cup Pull

Certification: Meets ANSI A156.6 for J403 Pulls  
Face: 5" x 5" (127 mm x 127 mm)  
Projection: 3/8" (9.5 mm)  
Opening: 3" x 3-1/2" (76 mm x 89 mm)  
Cup Clearance: 7/8" (22 mm)  
Materials: Stainless steel  
Finishes: US32D  
Fasteners: Four (4) 10-24 FPHMS (Security Torx) sex nuts and bolts (compatible with 1-3/4" doors only)  
Notes:

- ADA Compliant
- Not available for back to back mounting



### 27P

#### Security Flush Cup Pull

Certification: Meets ANSI A156.6 for J403 Pulls  
Face: 5" x 5" (127 mm x 127 mm)  
Projection: 3/8" (9.5 mm)  
Opening: 3" x 3-1/2" (76 mm x 89 mm)  
Cup Clearance: 7/8" (22 mm)  
Materials: Stainless steel  
Finishes: US32D  
Fasteners: Four (4) 1/4-20 x 3/4" Undercut FPHMS (Security Torx)  
Notes:

- ADA Compliant
- Not available for back to back mounting

## PULL PLATES



### 30, 40, 50 Series Pull Plate

Gauge: 0.050" (1.3 mm)  
 Certification: Meets ANSI A156.6 for J405 Pull Plate



### 80, 90, 100 Series Pull Plate

Gauge: 0.125" (3.2 mm)  
 Certification: Meets ANSI A156.6 for J407 Pull Plate



### A30, A40, A50 Series Pull Plate

Gauge: 0.062" (1.6 mm)  
 Certification: Meets ANSI A156.6 for J405 Pull Plate

Materials: Aluminum, brass, bronze, stainless steel  
 Standard Sizes: 3" x 12" (76 mm x 305 mm), 3-1/2" x 15" (89 mm x 381 mm), 4" x 16" (102 mm x 406 mm), 6" x 16" (152 mm x 406 mm)\*, 8" x 16" (203 mm x 406 mm)\* - \*(size not available for 50 and A50 Series)

Fasteners: Six (6) #6 x 5/8 OPH tapping screws  
 Finishes: US3, US4, US10, US10B, US26, US26D, US28, US32, US32D and diamond tread (A30 only)

Notes:
 

- For sizes or finishes not listed in this catalog, contact Hager Customer Service for availability
- Plate only - does not include pull

### How To Order:

- 1) Identify plate (ex: 30 Series)
- 2) Add pull (ex.: 36)
- 3) Add to order (ex: 33G)

Pull Plate Chart									
Pull	30, 40, 50 Series			A30, A40, A50 Series			80, 90, 100 Series		
	Square Corner	Radius Corner	Rounded Corner	Square Corner	Radius Corner	Rounded Corner	Square Corner	Radius Corner	Rounded Bevel
Pull Plate Part Number									
1E	31E	41E	51E	A31E	A41E	A51E	81E	91E	101E
1G	31G	41G	51G	A31G	A41G	A51G	81G	91G	101G
1J	31J	41J	51J	A31J	A41J	A51J	81J	91J	101J
1L	31L	41L	51L	A31L	A41L	A51L	81L	91L	101L
2E	32E	42E	52E	A32E	A42E	A52E	82E	92E	102E
2G	32G	42G	52G	A32G	A42G	A52G	82G	92G	102G
2J	32J	42J	52J	A32J	A42J	A52J	82J	92J	102J
2L	32L	42L	52L	A32L	A42L	A52L	82L	92L	102L
3E	33E	43E	53E	A33E	A43E	A53E	83E	93E	103E
3G	33G	43G	53G	A33G	A43G	A53G	83G	93G	103G
3J	33J	43J	53J	A33J	A43J	A53J	83J	93J	103J
3L	33L	43L	53L	A33L	A43L	A53L	83L	93L	103L
4G	34G	44G	54G	A34G	A44G	A54G	84G	94G	104G
4J	34J	44J	54J	A34J	A44J	A54J	84J	94J	104J
4L	34L	44L	54L	A34L	A44L	A54L	84L	94L	104L
5D	35D	45D	55D	A35D	A45D	A55D	85D	95D	105D
5N	35N	45N	55N	A35N	A45N	A55N	85N	95N	105N
6N	36N	46N	56N	A36N	A46N	A56N	86N	96N	106N
9E	39E	49E	59E	A39E	A49E	A59E	89E	99E	109E
9G	39G	49G	59G	A39G	A49G	A59G	89G	99G	109G
9J	39J	49J	59J	A39J	A49J	A59J	89J	99J	109J
9L	39L	49L	59L	A39L	A49L	A59L	89L	99L	109L





## PULL PLATES



### 313L

#### Antivandal Trim with Latchguard

- Certification: Meets ANSI A156.6 for J401 Pull and ANSI A156.6 for J407 Pull Plate  
 Size: 7-13/32" x 11" (188 mm x 280 mm)  
 Height: 11" (280 mm)  
 Projection: 1-7/8" (48 mm)  
 Clearance: 1-5/8" (41 mm)  
 Door Thickness: 1-3/4" – 2" (45 mm - 51 mm)  
 Materials: 11 gauge stainless steel  
 Finishes: US32D  
 Fasteners: 1/4-20 FPHMS with finish washers - Standard  
 Options:
- Cylinder cutout available - 1-1/4" (32 mm) diameter standard for exit device use and 1-1/2" (38 mm) diameter standard for mortise lock use
  - Plastisol grip available

#### Notes:

- For use with most mortise locks on out-swinging doors
- For use with many exit devices (thru bolts directly to device)
- Cylinders must be ordered separately
- When mounting trim to a Hager exit device, cylinder collar (2-649-0137) must be purchased to ensure proper installation (see instructions for more detail)
- When mounting trim to a Hager exit device, a 7/16" (11 mm) tall cylinder collar must be purchased when using a 1-1/4" - 1-3/8" (32 mm - 35 mm) long rim cylinder (see instructions for more detail)



### 313S

#### Antivandal Trim

- Certification: Meets ANSI A156.6 for J401 Pull and ANSI A156.6 for J407 Pull Plate  
 Size: 6-11/32" x 11" (161 mm x 280 mm)  
 Height: 11" (280 mm)  
 Projection: 1-7/8" (48 mm)  
 Clearance: 1-5/8" (41 mm)  
 Door Thickness: 1-3/4" – 2" (45 mm - 51 mm)  
 Materials: 11 gauge stainless steel  
 Finishes: US32D  
 Fasteners: 1/4-20 FPHMS with finish washers - Standard  
 Options:
- Cylinder cutout available - 1-1/4" (32 mm) diameter standard for exit device use and 1-1/2" (38 mm) diameter standard for mortise lock use
  - Plastisol grip available

#### Notes:

- For use with most mortise locks on in-swinging and out-swinging doors
- For use with many exit devices (thru bolts directly to device)
- Cylinders must be ordered separately
- When mounting trim to a Hager exit device, cylinder collar (2-649-0137) must be purchased to ensure proper installation (see instructions for more detail)
- When mounting trim to a Hager exit device, a 7/16" (11 mm) tall cylinder collar must be purchased when using a 1-1/4" - 1-3/8" (32 mm - 35 mm) long rim cylinder (see instructions for more detail)

## PUSH PLATES



### 30S | A30S

#### Square Corner - Beveled Push Plate

Certification: Meets ANSI A156.6 for J301 Push Plate  
 Gauge: • 30S - 0.050" (1.3 mm)  
 • A30S - 0.062" (1.6 mm)  
 Materials: Aluminum, brass, bronze, stainless steel  
 Finishes: US3, US4, US10, US10B, US26, US26D, US28, US32, US32D  
 Fasteners: Six (6) #6 x 5/8" OPH tapping screws  
 Options: May be ordered cut for cylinder (CFC) or engraved "PUSH"  
 Notes: For sizes or finishes not listed in this catalog, contact Hager Customer Service for availability

Available in Sizes					
Inches	3 x 12	3-1/2 x 15	4 x 16	6 x 16	8 x 16
Millimeters	76 x 305	89 x 38	102 x 406	152 x 406	203 x 406



### 40R | A40R

#### Radius Corner - Non-Beveled Push Plate

Certification: Meets ANSI A156.6 for J301 Push Plate  
 Gauge: • 40R - 0.050" (1.3 mm)  
 • A40R - 0.062" (1.6 mm)  
 Materials: Aluminum, brass, bronze, stainless steel  
 Finishes: US3, US4, US10, US10B, US26, US26D, US28, US32, US32D  
 Fasteners: Six (6) #6 x 5/8" OPH tapping screws  
 Options: May be ordered cut for cylinder (CFC) or engraved "PUSH"  
 Notes: For sizes or finishes not listed in this catalog, contact Hager Customer Service for availability

Available in Sizes					
Inches	3 x 12	3-1/2 x 15	4 x 16	6 x 16	8 x 16
Millimeters	76 x 305	89 x 38	102 x 406	152 x 406	203 x 406



### 50T | A50T

#### Round Corner - Non-Beveled Push Plate

Certification: Meets ANSI A156.6 for J301 Push Plate  
 Gauge: • 50T - 0.050" (1.3 mm)  
 • A50T - 0.062" (1.6 mm)  
 Materials: Aluminum, brass, bronze, stainless steel  
 Finishes: US3, US4, US10, US10B, US26, US26D, US28, US32, US32D  
 Fasteners: Six (6) #6 x 5/8" OPH tapping screws  
 Options: May be ordered cut for cylinder (CFC) or engraved "PUSH"  
 Notes: For sizes or finishes not listed in this catalog, contact Hager Customer Service for availability

Available in Sizes			
Inches	3 x 12	3-1/2 x 15	4 x 16
Millimeters	76 x 305	89 x 38	102 x 406





## PUSH PLATES



### 60S

#### Square Corner - Beveled Push Plate

**Certification:** Meets ANSI A156.6 for J304 Push Plate  
**Gauge:** 0.125" (3.2 mm)  
**Materials:** Plastic laminate  
**Finishes:** PG - Grey, PK - Black, CO - Brown  
**Fasteners:** Six (6) #6 x 5/8" OPH tapping screws  
**Options:** May be ordered cut for cylinder (CFC) or engraved "PUSH"  
**Notes:** For sizes or finishes not listed in this catalog, contact Hager Customer Service for availability

Available in Sizes					
Inches	3 x 12	3-1/2 x 15	4 x 16	6 x 16	8 x 16
Millimeters	76 x 305	89 x 38	102 x 406	152 x 406	203 x 406



### 70S

#### Square Corner - Beveled Push Plate

**Certification:** Meets ANSI A156.6 for J304 Push Plate  
**Gauge:** 0.125" (3.2 mm)  
**Materials:** Clear plastic laminate  
**Finishes:** PC - Clear  
**Fasteners:** Six (6) #6 x 5/8" OPH tapping screws  
**Options:** May be ordered cut for cylinder (CFC) or engraved "PUSH"  
**Notes:** For sizes or finishes not listed in this catalog, contact Hager Customer Service for availability

Available in Sizes					
Inches	3 x 12	3-1/2 x 15	4 x 16	6 x 16	8 x 16
Millimeters	76 x 305	89 x 38	102 x 406	152 x 406	203 x 406



### 80S

#### Square Corner - Beveled Push Plate

**Certification:** Meets ANSI A156.6 for J304 Push Plate  
**Gauge:** 0.125" (3.2 mm)  
**Materials:** Aluminum, brass, bronze, stainless steel  
**Finishes:** US3, US4, US10, US10B, US26, US26D, US28, US32, US32D  
**Fasteners:** Six (6) #6 x 5/8" OPH tapping screws  
**Options:** May be ordered cut for cylinder (CFC) or engraved "PUSH"  
**Notes:** For sizes or finishes not listed in this catalog, contact Hager Customer Service for availability

Available in Sizes					
Inches	3 x 12	3-1/2 x 15	4 x 16	6 x 16	8 x 16
Millimeters	76 x 305	89 x 38	102 x 406	152 x 406	203 x 406



## PUSH PLATES



### 90R

#### Radius Corner - Non-Beveled Push Plate

**Certification:** Meets ANSI A156.6 for J304 Push Plate  
**Gauge:** 0.125" (3.2 mm)  
**Materials:** Aluminum, brass, bronze, stainless steel  
**Finishes:** US3, US4, US10, US10B, US26, US26D, US28, US32, US32D  
**Fasteners:** Six (6) #6 x 5/8" OPH tapping screws  
**Options:** May be ordered cut for cylinder (CFC) or engraved "PUSH"  
**Notes:** For sizes or finishes not listed in this catalog, contact Hager Customer Service for availability

Available in Sizes					
Inches	3 x 12	3-1/2 x 15	4 x 16	6 x 16	8 x 16
Millimeters	76 x 305	89 x 38	102 x 406	152 x 406	203 x 406



### 100T

#### Square Corner - Rounded Bevel Top and Bottom Push Plate

**Certification:** Meets ANSI A156.6 for J304 Push Plate  
**Gauge:** 0.125" (3.2 mm)  
**Materials:** Aluminum, brass, bronze, stainless steel  
**Finishes:** US3, US4, US10, US10B, US26, US26D, US28, US32, US32D  
**Fasteners:** Six (6) #6 x 5/8" OPH tapping screws  
**Options:** May be ordered cut for cylinder (CFC) or engraved "PUSH"  
**Notes:** For sizes or finishes not listed in this catalog, contact Hager Customer Service for availability

Available in Sizes					
Inches	3 x 12	3-1/2 x 15	4 x 16	6 x 16	8 x 16
Millimeters	76 x 305	89 x 38	102 x 406	152 x 406	203 x 406



### 110S

#### Half Circle Push Plate

**Certification:** Meets ANSI A156.6 for J301 Push Plate  
**Plate:** 8" x 16" (203 mm x 406 mm)  
**Gauge:** 0.050" (1.3 mm)  
**Materials:** Aluminum, brass, bronze, stainless steel  
**Finishes:** US3, US4, US10B, US26, US26D, US28, US32, US32D  
**Fasteners:** Six (6) #6 x 5/8" OPH tapping screws  
**Options:** May be ordered cut for cylinder (CFC) or engraved "PUSH"  
**Notes:** For sizes or finishes not listed in this catalog, contact Hager Customer Service for availability





## PUSH PLATES



### 120L

#### Pull Plate with Lip - Non-Beveled

- Certification: Meets ANSI A156.6 for J303 Plate  
 Plate: 3-1/2" x 16" (89 mm x 406 mm)  
 Lip Projection: 1-1/8" (29 mm)  
 Gauge: 0.125" (3.2 mm)  
 Materials: Aluminum, brass, bronze, stainless steel  
 Finishes: US3, US4, US10, US10B, US26, US26D, US28, US32, US32D  
 Fasteners: Six (6) #6 x 5/8" OPH tapping screws  
 Options:
  - Other sizes available, please specify
  - May be ordered cut for cylinder (CFC) or engraved
 Notes: For sizes or finishes not listed in this catalog, contact Hager Customer Service for availability



### 121L

#### Cylinder Pull - Beveled

- Plate: 2" x 3-3/4" (51 mm x 95 mm)  
 Lip Projection: 1-1/8" (29 mm)  
 Cylinder Cutout: 1-1/4" (32 mm) diameter  
 Gauge: 0.125" (3.2 mm)  
 Materials: Aluminum, brass, bronze, stainless steel  
 Finishes: US3, US4, US10, US10B, US26, US26D, US28, US32, US32D  
 Fasteners: Attached by lock cylinder  
 Notes:
  - 1/4"-20 x 3/8" stud installed on reverse side to eliminate twisting
  - For sizes or finishes not listed in this catalog, contact Hager Customer Service for availability



### 122L

#### Security Pull/Push Plate Set - Beveled

- Certification: Meets ANSI A156.6 for combination J304 Push Plate and J303 Flush Pull  
 Push Plate: 4" x 16" (102 mm x 406 mm)  
 Pull Plate: 4" x 9-1/4" (102 mm x 235 mm)  
 Lip Projection: 2-1/8" (54 mm)  
 Gauge: 0.125" (3.2 mm)  
 Materials: Stainless steel  
 Finishes: US32D  
 Fasteners: Four (4) 8-32 FPHMS (Security Torx) sex nuts and bolts  
 Two (2) 8-32 x 1/2" FPHMS (Security Torx)  
 Notes: For sizes or finishes not listed in this catalog, contact Hager Customer Service for availability

## PUSH BARS



### 125S Bent Push Bar

Certification: Meets ANSI A156.6 for J501 Push Bar  
 Bar Size: 3/8" x 1-1/4" (10 mm x 32 mm)  
 Projection: 2-1/8" (54 mm)  
 Base Plate: 1" x 3" (25 mm x 76 mm)  
 Materials: Aluminum, brass, bronze, stainless steel  
 Finishes: US3, US4, US10, US10B, US28, US32, US32D  
 Fasteners: Two (2) #8 x 3/4" FPH tapping screws and one (1) 1/4 - 20 OPHMS  
 Options: May be ordered with thru bolts in place of surface screws



### 126S Push Bar

Certification: Meets ANSI A156.6 for J501 Push Bar  
 Bar Size: 3/8" x 1-1/4" (10 mm x 32 mm)  
 Projection: 2-1/8" (54 mm)  
 Base Plate: 1" x 3" (25 mm x 76 mm)  
 Materials: Aluminum, brass, bronze, stainless steel  
 Finishes: US3, US4, US10, US10B, US28, US32, US32D  
 Fasteners: Four (4) #8 x 3/4" FPH tapping screws  
 Options: May be ordered with thru bolts in place of surface screws



### 127S Push Bar

Certification: Meets ANSI A156.6 for J501 Push Bar  
 Bar Size: 3/8" x 1-1/4" (10 mm x 32 mm)  
 Projection: 3/4" (19 mm)  
 Base Plate: 1-1/4" x 1-1/4" (32 mm x 32 mm)  
 Materials: Aluminum, brass, bronze, stainless steel  
 Finishes: US3, US4, US10, US10B, US28, US32, US32D  
 Fasteners: Two (2) 1/4-20 FPHMS  
 Options: May be ordered with thru bolts in place of surface screws



### 128P Wide Push Bar

Certification: Meets ANSI A156.6 for J501 Push Bar  
 Bar Size: 3/8" x 3" (10 mm x 76 mm)  
 Projection: 2-1/8" (54 mm)  
 Base Plate: 1-1/2" x 4-1/2" (38 mm x 114 mm)  
 Materials: Aluminum, brass, bronze, stainless steel  
 Finishes: US3, US4, US10, US10B, US26, US26D, US28, US32, US32D  
 Fasteners: Eight (8) #8 x 3/4" FPH tapping screws





## PUSH BARS



### **128S** **Wide Push Bar**

Certification: Meets ANSI A156.6 for J501 Push Bar  
 Bar Size: 3/8" x 3" (10 mm x 76 mm)  
 Projection: 2" (51 mm)  
 Base Plate: 1-1/2" x 4-1/2" (38 mm x 114 mm)  
 Door Thickness: 1-3/4" (45 mm) - Standard  
 Materials: Aluminum, brass, bronze, stainless steel  
 Finishes: US3, US4, US10, US10B, US26, US26D, US28, US32, US32D  
 Fasteners: Two (2) 1/4 - 20 x 2-1/4" FPHMS with finish washers  
 Notes: 128S is same as 128P, but without base plates



### **129P** **Wide Push Bar**

Certification: Meets ANSI A156.6 for J501 Push Bar  
 Bar Size: 3/8" x 3" (10 mm x 76 mm)  
 Projection: 3/4" (19 mm)  
 Base Plate: 1" x 3" (25 mm x 76 mm)  
 Materials: Aluminum, brass, bronze, stainless steel  
 Finishes: US3, US4, US10, US10B, US28, US32, US32D  
 Fasteners: Two (2) 1/4-20 x 1-1/4" FPHMS  
 Options:
 

- May be ordered with thru bolts in place of surface screws
- #14 Flat head wood screws available on special order



### **130S** **Round Push Bar**

Certification: Meets ANSI A156.6 for J501 Push Bar  
 Bar Stock: 1" (25 mm)  
 Projection: 2-1/2" (64 mm)  
 Door Thickness: 1-3/4" (45 mm) - Standard  
 Materials: Aluminum, brass, bronze, stainless steel  
 Finishes: US3, US4, US10, US10B, US28, US32, US32D  
 Fasteners: Two (2) 1/4-20 x 20 x 2-1/4" FPHMS with finish washers  
 Options: May be ordered with Type 5 concealed mountings at extra charge



### **131S** **Round Push Bar**

Certification: Meets ANSI A156.6 for J501 Push Bar  
 Bar Stock: 1" (25 mm)  
 Projection: 2-5/8" (67 mm)  
 Base Diameter: 2" (51 mm)  
 Door Thickness: 1-3/4" (45 mm) - Standard  
 Materials: Aluminum, brass, bronze, stainless steel  
 Finishes: US3, US4, US10, US10B, US28, US32, US32D  
 Fasteners: Two (2) 1/4-20 x 2-1/4" FPHMS with finish washers  
 Options: May be ordered with Type 5 concealed mountings at extra charge

## PUSH BARS



### 133S

#### Round Push Bar

Certification: Meets ANSI A156.6 for J501 Push Bar  
Bar Stock: 3/4" (19 mm)  
Projection: 2-1/4" (57 mm)  
Door Thickness: 1-3/4" (45 mm) - Standard  
Materials: Aluminum, brass, bronze, stainless steel  
Finishes: US3, US4, US10, US10B, US28, US32, US32D  
Fasteners: Two (2) 1/4 - 20 x 2-1/4" FPHMS with finish washers



### 134S

#### Round Push Bar

Certification: Meets ANSI A156.6 for J501 Push Bar  
Bar Stock: 3/4" (19 mm)  
Projection: 2-3/8" (60 mm)  
Base Diameter: 1-1/4" (32 mm)  
Door Thickness: 1-3/4" (45 mm) - Standard  
Materials: Aluminum, brass, bronze, stainless steel  
Finishes: US3, US4, US10, US10B, US28, US32, US32D  
Fasteners: Two (2) 1/4 - 20 x 2-1/4" FPHMS with finish washers  
Options: May be ordered with Type 5 concealed mountings at extra charge



### 136S

#### Round Push Bar

Certification: Meets ANSI A156.6 for J501 Push Bar  
Bar Stock: 1-1/4" (32 mm)  
Projection: 3" (76 mm)  
Door Thickness: 1-3/4" (45 mm) - Standard  
Materials: Aluminum, brass, bronze, stainless steel  
Finishes: US3, US4, US10, US10B, US28, US32, US32D  
Fasteners: Two (2) 5/16 - 18 x 2-1/4" FPHMS with finish washers  
Options: May be ordered with Type 5 concealed mountings at extra charge



### 137S

#### Round Push Bar

Certification: Meets ANSI A156.6 for J501 Push Bar  
Bar Stock: 1-1/4" (32 mm)  
Projection: 3-1/8" (79 mm)  
Base Diameter: 2" (51 mm)  
Door Thickness: 1-3/4" (45 mm) - Standard  
Materials: Aluminum, brass, bronze, stainless steel  
Finishes: US3, US4, US10, US10B, US28, US32, US32D  
Fasteners: Two (2) 5/16 - 18 x 2-1/4" FPHMS with finish washers  
Options: May be ordered with Type 5 concealed mountings at extra charge





## PUSH & PULL BAR SETS



### 138P Round Push/Pull Set

Certification: Meets ANSI A156.6 for J504 Bar Sets  
 Bar Stock: 1" (25 mm)  
 Projection: 2-1/2" (64 mm)  
 Materials: Aluminum, brass, bronze, stainless steel  
 Finishes: US3, US4, US10, US10B, US28, US32, US32D  
 Fasteners: Two (2) 1/4-20 Type 3 concealed cone



### 139P Round Push/Pull Set

Certification: Meets ANSI A156.6 for J504 Bar Sets  
 Bar Stock: 3/4" (19 mm)  
 Projection: 2-1/4" (60 mm)  
 Materials: Aluminum, brass, bronze, stainless steel  
 Finishes: US3, US4, US10, US10B, US28, US32, US32D  
 Fasteners: Two (2) 1/4-20 Type 3 concealed cone



### 140P Round Push/Pull Set

Certification: Meets ANSI A156.6 for J504 Bar Sets  
 Bar Stock: 1-1/4" (32 mm)  
 Projection: 3" (76 mm)  
 Materials: Aluminum, brass, bronze, stainless steel  
 Finishes: US3, US4, US10, US10B, US28, US32, US32D  
 Fasteners: Two (2) 5/16-18 Type 3 concealed cone



### 150D | 150V | 150B Round Push/Pull Set\*

Certification: Meets ANSI A156.6 for J504 Bar Sets  
 Bar Stock: 3/4" (19 mm)  
 Projection: 2-1/4" (57 mm)  
 Pull CTC: 8" (203 mm)  
 Materials: Aluminum, brass, bronze, stainless steel  
 Finishes: US3, US4, US10, US10B, US28, US32, US32D

\*  
**D = Standard Fastening** - One (1) 3/8-16 Type 7 spanner collar connection between push bar and pull plus two (2) 1/4-20 Type 1 connections for other ends of push bar and pull.  
**V = Fully Concealed Fastening** - One (1) 3/8-16 Type 7 spanner collar connection between push bar and pull plus two (2) 1/4-20 Type 5 connections for ends of push bar and pull.  
**B = Tempered Glass Fastening** - One (1) 3/8-16 Type 7 spanner collar connection between push bar and pull plus two (2) 1/4-20 Type 8 connections for ends of push bar and pull plus gaskets that separate metal parts from glass.

## PUSH & PULL BAR SETS



### 151D | 151V | 151B

#### Round Push/Pull Set\*

Certification: Meets ANSI A156.6 for J504 Bar Sets  
 Bar Stock: 3/4" (19 mm)  
 Projection: 2-1/4" (57 mm)  
 Pull CTC: 10" (254 mm)  
 Materials: Aluminum, brass, bronze, stainless steel  
 Finishes: US3, US4, US10, US10B, US28, US32, US32D



### 152D | 152V | 152B

#### Round Push/Pull Set\*

Certification: Meets ANSI A156.6 for J504 Bar Sets  
 Bar Stock: 3/4" (19 mm)  
 Projection: 2-1/4" (57 mm)  
 Pull CTC: 12" (305 mm)  
 Materials: Aluminum, brass, bronze, stainless steel  
 Finishes: US3, US4, US10, US10B, US28, US32, US32D



### 153D | 153V | 153B

#### Round Push/Pull Set\*

Certification: Meets ANSI A156.6 for J504 Bar Sets  
 Bar Stock: 1" (25 mm)  
 Projection: 2-1/2" (64 mm)  
 Pull CTC: 10" (254 mm)  
 Materials: Aluminum, brass, bronze, stainless steel  
 Finishes: US3, US4, US10, US10B, US28, US32, US32D



### 154D | 154V | 154B

#### Round Push/Pull Set\*

Certification: Meets ANSI A156.6 for J504 Bar Sets  
 Bar Stock: 1" (25 mm)  
 Projection: 2-1/2" (64 mm)  
 Pull CTC: 12" (305 mm)  
 Materials: Aluminum, brass, bronze, stainless steel  
 Finishes: US3, US4, US10, US10B, US28, US32, US32D

\*

**D = Standard Fastening** - One (1) 3/8-16 Type 7 spanner collar connection between push bar and pull plus two (2) 1/4-20 Type 1 connections for other ends of push bar and pull.

**V = Fully Concealed Fastening** - One (1) 3/8-16 Type 7 spanner collar connection between push bar and pull plus two (2) 1/4-20 Type 5 connections for ends of push bar and pull.

**B = Tempered Glass Fastening** - One (1) 3/8-16 Type 7 spanner collar connection between push bar and pull plus two (2) 1/4-20 Type 8 connections for ends of push bar and pull plus gaskets that separate metal parts from glass.





## PUSH & PULL BAR SETS



### 155D | 155V | 155B

#### Round Push/Pull Set\*

Certification: Meets ANSI A156.6 for J504 Bar Sets  
 Bar Stock: 1" (25 mm)  
 Projection: 2-1/2" (64 mm)  
 Pull CTC: 18" (457 mm)  
 Materials: Aluminum, brass, bronze, stainless steel  
 Finishes: US3, US4, US10, US10B, US28, US32, US32D



### 156D | 156V | 156B

#### Round Push/Pull Set\*

Certification: Meets ANSI A156.6 for J505 Bar Sets  
 Bar Stock: 3/4" (19 mm) diameter  
 Pull Bar Projection: 2-1/2" (64 mm)  
 Push Bar Projection: 2-1/4" (57 mm)  
 Pull CTC: 8" (203 mm)  
 Offset: 2-1/2" (64 mm), 90° Standard  
 Materials: Aluminum, brass, bronze, stainless steel  
 Finishes: US3, US4, US10, US10B, US28, US32, US32D  
 Options: For 45° offset pull, add prefix "X" (i.e., X156D) to number  
 Notes: Non-reversible; specify handing



### 157D | 157V | 157B

#### Round Push/Pull Set\*

Certification: Meets ANSI A156.6 for J505 Bar Sets  
 Bar Stock: 3/4" (19 mm) diameter  
 Pull Bar Projection: 2-1/2" (64 mm)  
 Push Bar Projection: 2-1/4" (57 mm)  
 Pull CTC: 10" (254 mm)  
 Offset: 2-1/2" (64 mm), 90° Standard  
 Materials: Aluminum, brass, bronze, stainless steel  
 Finishes: US3, US4, US10, US10B, US28, US32, US32D  
 Options: For 45° offset pull, add prefix "X" (i.e., X157D) to number  
 Notes: Non-reversible; specify handing



### 158D | 158V | 158B

#### Round Push/Pull Set\*

Certification: Meets ANSI A156.6 for J505 Bar Sets  
 Bar Stock: 3/4" (19 mm) diameter  
 Pull Bar Projection: 2-1/2" (64 mm)  
 Push Bar Projection: 2-1/4" (57 mm)  
 Pull CTC: 12" (305 mm)  
 Offset: 2-1/2" (64 mm), 90° Standard  
 Materials: Aluminum, brass, bronze, stainless steel  
 Finishes: US3, US4, US10, US10B, US28, US32, US32D  
 Options: For 45° offset pull, add prefix "X" (i.e., X158D) to number  
 Notes: Non-reversible; specify handing

\*

**D = Standard Fastening** - One (1) 3/8-16 Type 7 spanner collar connection between push bar and pull plus two (2) 5/16-18 Type 1 connections for other ends of push bar and pull.

**V = Fully Concealed Fastening** - One (1) 3/8-16 Type 7 spanner collar connection between push bar and pull plus two (2) 5/16-18 Type 5 connections for ends of push bar and pull.

**B = Tempered Glass Fastening** - One (1) 3/8-16 Type 7 spanner collar connection between push bar and pull plus two (2) 5/16-18 Type 8 connections for ends of push bar and pull plus gaskets that separate metal parts from glass.



## PUSH & PULL BAR SETS



### 159D | 159V | 159B

#### Round Push/Pull Set\*

Certification: Meets ANSI A156.6 for J505 Bar Sets  
 Bar Stock: 1" (25 mm)  
 Projection: 2-1/2" (64 mm)  
 Pull CTC: 10" (254 mm)  
 Offset: 3" (76 mm), 90° Standard  
 Materials: Aluminum, brass, bronze, stainless steel  
 Finishes: US3, US4, US10, US10B, US28, US32, US32D  
 Options: For 45° offset pull, add prefix "X" to number (i.e., X159D)  
 Notes: Non-reversible; specify handing



### 160D | 160V | 160B

#### Round Push/Pull Set\*

Certification: Meets ANSI A156.6 for J505 Bar Sets  
 Bar Stock: 1" (25 mm)  
 Projection: 2-1/2" (64 mm)  
 Pull CTC: 12" (305 mm)  
 Offset: 3" (76 mm), 90° Standard  
 Materials: Aluminum, brass, bronze, stainless steel  
 Finishes: US3, US4, US10, US10B, US28, US32, US32D  
 Options: For 45° offset pull, add prefix "X" to number (i.e., X160D)  
 Notes: Non-reversible; specify handing



### 161D | 161V | 161B

#### Round Push/Pull Set\*

Certification: Meets ANSI A156.6 for J505 Bar Sets  
 Bar Stock: 1" (25 mm)  
 Projection: 2-1/2" (64 mm)  
 Pull CTC: 18" (457 mm)  
 Offset: 3" (76 mm), 90° Standard  
 Materials: Aluminum, brass, bronze, stainless steel  
 Finishes: US3, US4, US10, US10B, US28, US32, US32D  
 Options: For 45° offset pull, add prefix "X" to number (i.e., X161D)  
 Notes: Non-reversible; specify handing



### 164D | 164V | 164B

#### Round Push/Pull Set\*

Certification: Meets ANSI A156.6 for J504 Bar Sets  
 Bar Stock: 1-1/4" (32 mm)  
 Projection: 3" (76 mm)  
 Pull CTC: 12" (305 mm)  
 Materials: Aluminum, brass, bronze, stainless steel  
 Finishes: US3, US4, US10, US10B, US28, US32, US32D

\*

**D = Standard Fastening** - One (1) 3/8-16 Type 7 spanner collar connection between push bar and pull plus two (2) 5/16-18 Type 1 connections for other ends of push bar and pull.

**V = Fully Concealed Fastening** - One (1) 3/8-16 Type 7 spanner collar connection between push bar and pull plus two (2) 5/16-18 Type 5 connections for ends of push bar and pull.

**B = Tempered Glass Fastening** - One (1) 3/8-16 Type 7 spanner collar connection between push bar and pull plus two (2) 5/16-18 Type 8 connections for ends of push bar and pull plus gaskets that separate metal parts from glass.





## PUSH & PULL BAR SETS



### 165D | 165V | 165B

#### Round Push/Pull Set\*

Certification: Meets ANSI A156.6 for J504 Bar Sets  
 Bar Stock: 1-1/4" (32 mm)  
 Projection: 3" (76 mm)  
 Pull CTC: 18" (457 mm)  
 Materials: Aluminum, brass, bronze, stainless steel  
 Finishes: US3, US4, US10, US10B, US28, US32, US32D



### 167D | 167V | 167B

#### Round Push/Pull Set\*

Certification: Meets ANSI A156.6 for J505 Bar Sets  
 Bar Stock: 1-1/4" (32 mm)  
 Projection: 3" (76 mm)  
 Pull CTC: 18" (457 mm)  
 Offset: 3-3/4" (96 mm), 90° Standard  
 Materials: Aluminum, brass, bronze, stainless steel  
 Finishes: US3, US4, US10, US10B, US28, US32, US32D  
 Notes: Non-reversible; specify handing



### 170D

#### Push/Pull Set

Certification: Meets ANSI A156.6 for J502 Bar Sets  
 Bar Stock: 3/8" x 1-1/4" (10 mm x 32 mm)  
 Pull Bar Projection: 2-1/2" (64 mm)  
 Push Bar Projection: 3/4" (19 mm)  
 Base: 1-1/4" x 1-1/4" (32 x 32 mm)  
 Horizontal Spacing CTC: 8" (203 mm)  
 Materials: Aluminum, brass, bronze, stainless steel  
 Finishes: US3, US4, US10, US10B, US28, US32, US32D  
 Notes:
 

- Bars are mounted back to back with 1/4"-20 thru bolt type 4 mounting
- Non-reversible; specify handing

\*

**D = Standard Fastening** - One (1) 3/8-16 Type 7 spanner collar connection between push bar and pull plus two (2) 5/16-18 Type 1 connections for other ends of push bar and pull.

**V = Fully Concealed Fastening** - One (1) 3/8-16 Type 7 spanner collar connection between push bar and pull plus two (2) 5/16-18 Type 5 connections for ends of push bar and pull.

**B = Tempered Glass Fastening** - One (1) 3/8-16 Type 7 spanner collar connection between push bar and pull plus two (2) 5/16-18 Type 8 connections for ends of push bar and pull plus gaskets that separate metal parts from glass.

All push bar units are made to order. Specify CTC lengths, fastening method unless standard, and type of door (WO, HM, AL, etc.).



## DOOR EDGINGS & CORNER GUARDS

### 180H | 180K | 180M | 180P | 180Q

#### Mortise Door Edging

Certification: Meets ANSI A156.6 Door Edging Type J201 through J212

Standard Length: 36" – 42" (914 mm – 1067 mm)

Materials: Aluminum, stainless steel

Gauge: 0.045" - 0.050" (1.1 mm - 1.3 mm)

Finishes: US28, US32D

Fasteners: #6 x 3/4" FPH tapping screws

Options:

- Other lengths by quotation
- Hinge cutout available
- Latch cutout available
- UL rated edging available

Order:

- Provide actual rather than typical door thickness
- Provide item #, size and finish (i.e., 180H - 40"-32D)

Notes:

- Cutout will hand edging; specify handing information
- Standard edge guards are made for 1-3/4" +0, -1/32" thick doors

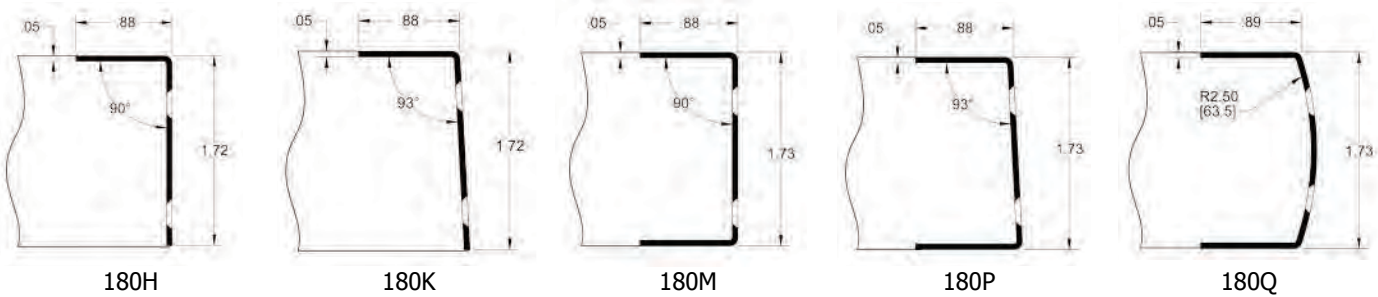

### 181H | 181K | 181M | 181P | 181Q

#### Overlap Door Edging

Certification: Meets ANSI A156.6 Door Edging Type J201 through J212

Standard Length: 36" – 42" (914 mm – 1067 mm)

Materials: Aluminum, stainless steel

Gauge: 0.045" - 0.050" (1.1 mm - 1.3 mm)

Finishes: US28, US32D

Fasteners: #6 x 3/4" FPH tapping screws

Options:

- Other lengths by quotation
- Hinge cutout available
- Latch cutout available
- UL rated edging available

Order:

- Provide actual rather than typical door thickness
- Provide item #, size and finish (i.e., 181H - 40"-32D)

Notes:

- Cutout will hand edging; specify handing information
- Standard edge guards are made for 1-3/4" +0, -1/32" thick doors

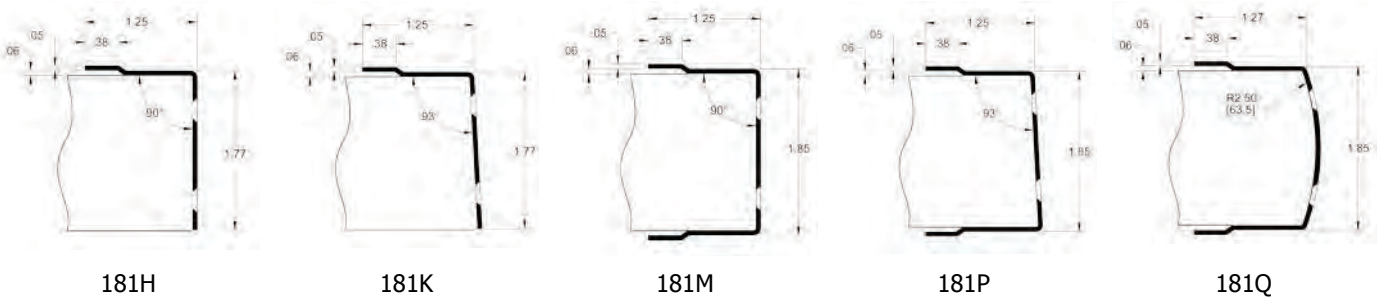



## DOOR EDGINGS & CORNER GUARDS

### 182H | 182K | 182M | 182P | 182Q

#### Non-Mortise Door Edging

- Certification: Meets ANSI A156.6 Door Edging Type J201 through J212
- Standard Length: 36" – 42" (914 mm – 1067 mm)
- Materials: Aluminum, stainless steel
- Gauge: 0.045" - 0.050" (1.1 mm - 1.3 mm)
- Finishes: US28, US32D
- Fasteners: #6 x 3/4" FPH tapping screws
- Options:
- Other lengths by quotation
  - Hinge cutout available
  - Latch cutout available
  - UL rated edging available
- Order:
- Provide actual rather than typical door thickness
  - Provide item #, size and finish (i.e., 182H - 40"-32D)
- Notes:
- Cutout will hand edging; specify handing information
  - Standard edge guards are made for 1-3/4" +0, -1/32" thick doors

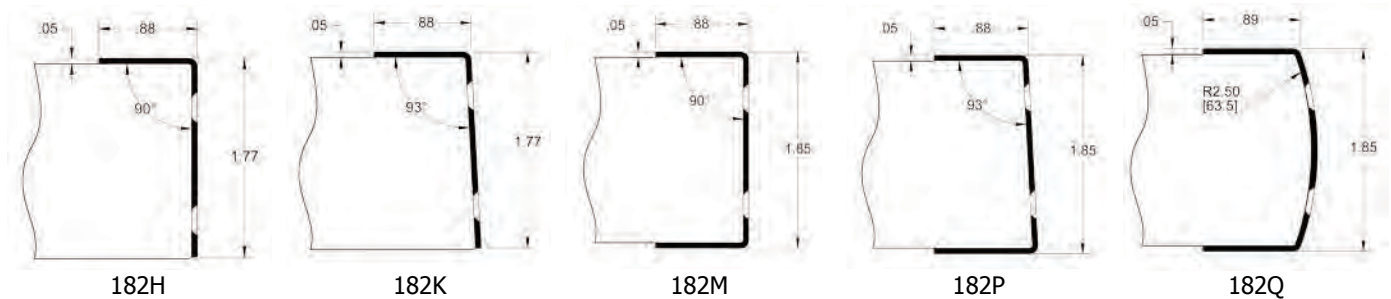

### 185G Corner Guard

- Certification: Meets ANSI A156.6 for J210
- Size: 3" x 3" x 40" (76 mm x 76 mm x 1016 mm)
- Gauge: 0.050" (1.3 mm)
- Materials: Aluminum, stainless steel
- Finishes: US28, US32D
- Fasteners: #6 x 5/8" FPHSMS self drilling screws
- Options: Mounting with double-stick tape instead of screws
- Notes:
- 90° bend standard
  - Other lengths by quotation

## DOOR PROTECTION PLATES



### Door Protection Plates

The metal door protection plates below meet ANSI A156.6 for J101 Metal Armor Plate, J102 Metal Kickplate, and J103 Metal Mop Plate. The plastic door protection plates below meet ANSI A156.6 for J105 Plastic Armor Plate, J106 Plastic Kickplate, and J107 Plastic Mop Plate. Options for all plates include countersunk holes, UL armor plate stamped, self-adhesive tape, spanner head screws, torx head screws, round corners, wrap around side and bottom return, and 0.125" (3.2 mm) material. All plates below are supplied standard with #6 x 5/8" truss head screws (unless specified otherwise). They are available in mop plate, kick plate, stretcher plate, and armor plate sizes.

- Mop Plate:** Protects the bottom of the pull side of doors subject to cleaning and mopping procedures.  
**Kick Plate:** Protects the bottom of the push side of doors subject to scuffing from foot traffic.  
**Stretcher Plate:** Protects doors in specific areas where constant contact is made by stretchers, service carts, or other equipment.  
**Armor Plate:** Protects lower half of doors from abuse by carts, trucks, and rough usage.

### NFPA 80 STANDARD 6.4.5.1/6.4.5.2 /6.4.5.3 Protection Plates

- Factory installed protection plates shall be installed in accordance with the listing of the door.
- Field installed protection plate shall be labeled and installed in accordance with their listing.
- Labeling is not required where the top of the protection plate is not more than 16" (406 mm) above the bottom of the door.

#### 190S

Thickness: 0.050" (1.3 mm)  
 U.S. Gauge: 18  
 Materials: Aluminum, brass, bronze, stainless steel  
 Finishes: US3, US4, US10, US10B, US28, US32, US32D  
 Bevel: None  
 Options: UL Listed for US32 and US32D\*

#### 193S

Thickness: 0.050" (1.3 mm)  
 U.S. Gauge: 18  
 Materials: Aluminum, brass, bronze, stainless steel  
 Finishes: US3, US4, US10, US10B, US28, US32, US32D  
 Bevel: 3 edges  
 Options: UL Listed for US32 and US32D\*

#### 194S

Thickness: 0.050" (1.3 mm)  
 U.S. Gauge: 18  
 Materials: Aluminum, brass, bronze, stainless steel  
 Finishes: US3, US4, US10, US10B, US28, US32, US32D  
 Bevel: 4 edges  
 Options: UL Listed for US32 and US32D\*

#### 198S

Thickness: 0.038" (0.8 mm)  
 U.S. Gauge: 20  
 Materials: Stainless steel  
 Finishes: US32D  
 Options: UL Listed\*

#### 199B

Thickness: 0.038" (0.8 mm)  
 U.S. Gauge: 20  
 Materials: Aluminum  
 Finishes: Bright gold anodized  
 Fasteners: #6 x 5/8" TPH Tapping Screws

#### 204S

Thickness: 0.125" (3.2 mm)  
 Materials: Clear plastic  
 Bevel: 4 edges

#### 214S

Thickness: 0.125" (3.2 mm)  
 Materials: Plastic laminate  
 Bevel: 4 edges  
 Colors: Black, Brown, Grey  
 Notes: Other colors are available and will be subject to minimum order quantities; priced on application

#### 220S

Thickness: 0.062" (1.6 mm)  
 U.S. Gauge: 16  
 Materials: Aluminum, brass, bronze, stainless steel  
 Finishes: US3, US4, US10, US10B, US28, US32, US32D, (diamond tread available in US26 only)  
 Bevel: None

#### 223S

Thickness: 0.062" (1.6 mm)  
 U.S. Gauge: 16  
 Materials: Aluminum, brass, bronze, stainless steel  
 Finishes: US3, US4, US10, US10B, US28, US32, US32D  
 Bevel: 3 edges

#### 224S

Thickness: 0.062" (1.6 mm)  
 U.S. Gauge: 16  
 Materials: Aluminum, brass, bronze, stainless steel  
 Finishes: US3, US4, US10, US10B, US28, US32, US32D  
 Bevel: 4 edges

#### 225S

Thickness: 0.060" (1.9 mm)  
 Materials: Kydex®  
 Colors: CBO - Calcutta Black, KGO - Beige, KHO - Chocolate  
 Notes: Other colors are available and will be subject to minimum order quantities; priced on application  
 Options: UL Listed\*

\*Must specify UL stamp. UL labeling not required when top of plate is less than 16" above the bottom of the door. Screw fasteners only.





## WALL STOPS & HOLDERS



### 230W Convex Wall Stop

Certification: Meets ANSI A156.16 for L02101  
 Diameter: 2-15/32" (63 mm)  
 Projection: 1-3/32" (28 mm)  
 Materials: Cast brass, bronze with grey rubber bumper  
 Finishes: US3, US4, US10, US10B, US15, US15A, US19, US26, US26D  
 Fasteners: One (1) #10 x 1-1/2" PPHWS with plastic and toggle anchor.  
 Notes:
 

- Concealed tamper proof mounting
- Easy installation by inserting screwdriver through small hole in bumper
- Specify 230T for machine screw and toggle nut screwpack (10 pk)



### 232W | BL232W Convex Wall Stop

Certification: Meets ANSI A156.16 for L02101  
 Diameter: 2-7/16" (62 mm)  
 Projection: 1" (25 mm)  
 Materials: Wrought brass, bronze, stainless steel with grey rubber bumper  
 Finishes: US3, US4, US5, US9, US10, US10B, US15, US15A, US19, US26, US26D, US32, US32D  
 Fasteners: One (1) #10 x 1-1/2" PPHWS with plastic and toggle anchor  
 Notes:
 

- Concealed tamper proof mounting
- Easy installation by inserting screwdriver through small hole in bumper
- Specify 230T for machine screw and toggle nut screwpack (10 pk)
- BL232W is 232W case quantity 50



### 234W Concave Wall Stop

Certification: Meets ANSI A156.16 for L02251  
 Diameter: 2-15/32" (63 mm)  
 Projection: 1-3/32" (28 mm)  
 Materials: Cast brass, bronze with grey rubber bumper  
 Finishes: US3, US4, US10, US10B, US15, US15A, US19, US26, US26D  
 Fasteners: One (1) #10 x 1-1/2" PPHWS w/ plastic and toggle anchor  
 Notes:
 

- Easy installation by inserting screwdriver through small hole in rubber bumper
- Concealed tamper proof mounting
- Concave rubber bumper prevents damage to locksets with projecting buttons
- Specify 230T for machine screw and toggle nut screwpack (10 pk)



### 236W | BL236W Concave Wall Stop

Certification: Meets ANSI A156.16 for L02251  
 Diameter: 2-7/16" (75 mm)  
 Projection: 1" (25 mm)  
 Materials: Wrought brass, bronze, stainless steel with grey rubber bumper  
 Finishes: US3, US4, US5, US9, US10, US10B, US15, US15A, US19, US26, US26D, US32, US32D  
 Fasteners: One (1) #10 x 1-1/2" PPHWS w/ plastic and toggle anchor  
 Notes:
 

- Easy installation by inserting screwdriver through small hole in rubber bumper
- Concealed tamper proof mounting
- Concave rubber bumper prevents damage to locksets with projecting buttons
- Specify 230T for machine screw and toggle nut screwpack (10 Pk)
- BL236W is 236W case quantity 50

## WALL STOPS & HOLDERS



### 250W

#### Convex Wall Stop

Diameter: 1" (25 mm)  
 Projection: 9/16" (14 mm)  
 Materials: Cast brass  
 Finishes: US3, US4, US10, US10B, US15, US15A, US19, US26, US26D  
 Fasteners: One (1) #6 x 3/4" screw with plastic anchor and one (1) 0.052 diameter nail  
 Notes:
 

- Concealed mounting screw prevents vandalism
- For use on drywall
- Compact design



### 251W

#### Concave Wall Stop

Diameter: 1-7/8" (48 mm)  
 Projection: 25/32" (20 mm)  
 Materials: Adhesive backed rubber bumper  
 Finish: Grey only  
 Notes:
 

- Concave bumper prevents damage to locksets with projecting buttons
- For areas where concealed mounting is not required
- Adhesive backing for use on clean smooth flat surfaces only



### 254S

#### Wall Stop & Holder

Certification: Meets ANSI A156.16 for L01341  
 Base Diameter: 2-11/32" (60 mm)  
 Base Projection: 3-1/2" (89 mm)  
 Engaged Projection: 5-19/32" (142 mm)  
 Keeper: 1" x 2" (25 mm x 51 mm)  
 Materials: Cast brass with black rubber bumper  
 Finishes: US3, US4, US10, US10B, US15, US26, US26D  
 Fasteners: Five (5) #10 x 1" FPHWS, and three (3) plastic anchors  
 Notes:
 

- For use on drywall
- Manual holder ideal for interior and exterior applications
- Unit functions as a stop, but can serve as a "Hold Open" when hook is manually engaged
- Ideal for use with locksets with a projection of 3-5/16" (84 mm) or less



### 254W

#### Wall Stop & Holder

Certification: Meets ANSI A156.16 for L01351  
 Base Diameter: 2-11/32" (60 mm)  
 Base Projection: 3-1/2" (89 mm)  
 Engaged Projection: 5-19/32" (142 mm)  
 Keeper: 1" x 2" (25 mm x 51 mm)  
 Materials: Cast brass with black rubber bumper  
 Finishes: US3, US4, US10, US10B, US15, US26, US26D  
 Fasteners: Three (3) #10 x 1" FPH tapping screw, one (1) plastic anchor, one (1) 5/16-18 x 2-1/2" threaded stud, and one (1) 5/16-18 lead anchor  
 Notes:
 

- For use on concrete walls
- Manual holder ideal for interior and exterior applications
- Unit functions as a stop, but can serve as a "Hold Open" when hook is manually engaged
- Ideal for use with locksets with a projection of 3-5/16" (84 mm) or less





## WALL STOPS & HOLDERS



### 255S

#### Wall Stop

- Certification: Meets ANSI A156.16 for L02011  
 Base Diameter: 2-11/32" (60 mm)  
 Projection: 3-11/16" (94 mm)  
 Materials: Cast brass with black rubber bumper  
 Finishes: US3, US4, US10, US10B, US15, US26, US26D  
 Fasteners: Three (3) #10 x 1" OPHWS and three (3) plastic anchors  
 Notes:
  - For use on drywall
  - Ideal for interior and exterior applications
  - Heavy duty - for use in high traffic areas
  - Ideal for use with locksets with a projection of 3" (76 mm) or less



### 255W

#### Wall Stop

- Certification: Meets ANSI A156.16 for L02021  
 Base Diameter: 2-11/32" (60 mm)  
 Projection: 3-11/16" (94 mm)  
 Materials: Cast brass with black rubber bumper  
 Finishes: US3, US4, US10, US10B, US15, US26, US26D  
 Fasteners: One (1) #10 x 1" OPHWS, one (1) plastic anchor, one (1) 5/16-18 lead anchor, one (1) 5/16-18 x 2-1/2" threaded stud, one (1) 5/16-18 x 2-1/2" combo threaded stud  
 Notes:
  - For use on concrete walls
  - Ideal for interior and exterior applications
  - Heavy duty - for use in high traffic areas
  - Ideal for use with locksets with a projection of 3" (76 mm) or less



### 256S

#### Manual Wall Stop & Holder

- Certification: Meets ANSI A156.16 for L01341  
 Base Diameter: 2-1/4" (57 mm)  
 Base Projection: 3-3/4" (95 mm)  
 Engaged Projection: 5-11/16" (145 mm)  
 Keeper: 25/32" x 1-1/2" (20 mm x 38 mm)  
 Materials: Cast brass with black rubber bumper  
 Finishes: US3, US10, US10B, US15, US26, US26D  
 Fasteners: Three (3) #10 x 1" OPHWS and three (3) plastic anchors  
 Notes:
  - For use on drywall
  - Ideal for interior and exterior applications
  - Heavy duty - for use in high traffic areas
  - Unit functions as a stop, but can serve as a "Hold Open" when hook is manually engaged
  - Ideal for use with locksets with a projection of 3" (76 mm) or less



## WALL STOPS & HOLDERS



### 256W

#### Manual Wall Stop & Holder

Certification: Meets ANSI A156.16 for L01351  
 Base Diameter: 2-1/4" (57 mm)  
 Base Projection: 3-3/4" (95 mm)  
 Engaged Projection: 5-11/16" (145 mm)  
 Keeper: 25/32" x 1-1/2" (20 mm x 38 mm)  
 Materials: Cast brass with black rubber bumper  
 Finishes: US3, US10, US10B, US15, US26, US26D  
 Fasteners: One (1) #10 x 1" OPHWS, one (1) plastic anchor, one (1) 5/16-18 lead anchor, one (1) 5/16-18 x 2-1/2" threaded stud, and one (1) 5/16-18 x 2-1/2" combo threaded stud

#### Notes:

- For use on concrete walls
- Ideal for interior and exterior applications
- Heavy duty - for use in high traffic areas
- Unit functions as a stop, but can serve as a "Hold Open" when hook is manually engaged
- Ideal for use with locksets with a projection of 3" (76 mm) or less



### 260W

#### Angled Wall Stop

Certification: Meets ANSI A156.16 for L02201  
 Base: 2-3/16"x 2-15/16" (56 mm x 75 mm)  
 Projection: 3-21/32" (93 mm)  
 Materials: Cast brass with black rubber bumper  
 Finishes: US26D  
 Fasteners: Three (3) #14 x 1-1/2" FPHWS, three (3) 1/4-20 x 3/4" FPHMS, three (3) plastic anchors, and three (3) 1/4-20 lead anchors

#### Notes:

- For use with drywall or concrete walls
- Sloping design resists vandalism
- Ideal for use with locksets with a projection of 3" (76 mm) or less



### 324W

#### Light Duty Wall Bumper

Certification: Meets ANSI A156.16 for L02031  
 Base Diameter: 1-1/4" (32 mm)  
 Projection: 3-1/4" (83 mm)  
 Tip Diameter: 5/8" (16 mm)  
 Materials: Cast brass, bronze with white rubber tip  
 Finishes: US3, US4, US5, US10, US10B, US15, US15A, US19, US26, US26D  
 Fastener: #10 x 7/8" wood thread

#### Notes:

- Replaceable rubber tip available
- Hex shape near the tip allows usage of a wrench for easier installation



## WALL STOPS & HOLDERS



### 326W

#### Automatic Wall Stop & Holder

Certification: Meets ANSI A156.16 for L01293  
 Holder Base: 2-13/32" x 2-25/32" (61 mm x 71 mm)  
 Holder Projection: 2-5/16" (59 mm)  
 Engaged Projection: 3-5/8" (92 mm)  
 Strike Base: 1" x 2-1/16" (25 mm x 52 mm)  
 Strike Projection: 2" (51 mm)  
 Keeper: 1" x 2" (25 mm x 51 mm)  
 Materials: Cast brass  
 Finishes: US3, US10, US10B, US26, US26D  
 Fasteners: Five (5) #10 x 1" OPHWS, three (3) 10-24 x 1-1/4" FPHMS, and three (3) plastic anchors

#### Notes:

- For use with wood or metal doors
- Holder is mounted on the door
- Roller is spring loaded to seat on strike - heavy duty rubber pad dampens sound and shock
- Ideal for use with locksets with a projection of 3" (76 mm) or less



### 327W

#### Automatic Wall Stop & Holder

Certification: Meets ANSI A156.16 for L11291  
 Holder Base: 3-1/16" x 3-1/2" (78 mm x 89 mm)  
 Holder Projection: 1-15/16" (49 mm)  
 Engaged Projection: 3-1/2" (89 mm)  
 Strike Diameter: 2-3/8" (60 mm)  
 Strike Projection: 3-1/16" (78 mm)  
 Materials: Cast brass  
 Finishes: US3, US4, US10, US10B, US26, US26D  
 Fasteners: Three (3) #14 x 1-1/2" FPHWS, three (3) 1/4-20 x 3/4" FPHMS, four (4) 12-24 x 1" TPHMS, four (4) #12 x 1" TPHWS, and three (3) 1/4-20 lead anchors

#### Notes:

- For use with wood or metal doors
- For use with drywall or concrete walls
- Roller is spring loaded to seat on strike - heavy duty rubber pad dampens sound and shock
- Strike is adjustable 45° left or right
- Holder has vertical adjustment once mounted on the door
- Ideal for use with locksets with a projection of 3" (76 mm) or less
- For doors up to 500 lbs

## ROLLER STOPS



### 271W

#### Roller Bumper

- Certification: Meets ANSI A156.16 for L02193  
 Base Diameter: 2" (51 mm)  
 Projection: 4-1/2" (114 mm)  
 Materials: Cast brass with grey rubber roller  
 Finishes: US3, US10, US10B, US26, US26D  
 Fasteners: Three (3) #10 x 1" FPHWS and three (3) plastic anchors  
 Notes:
  - For use when two doors swing into each other at right angles (back to back)
  - Prevents damage to the door and door hardware

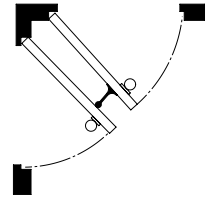

### 272W

#### Roller Bumper

- Certification: Meets ANSI A156.16 for L02193  
 Base Diameter: 2" (51 mm)  
 Projection: 6-1/4" (159 mm)  
 Materials: Cast brass with grey rubber roller  
 Finishes: US3, US10, US10B, US26, US26D  
 Fasteners: Three (3) #10 x 1" FPHWS, and three (3) plastic anchors  
 Notes:
  - For use when two doors swing into each other at right angles (back to back)
  - Prevents damage to the door and door hardware

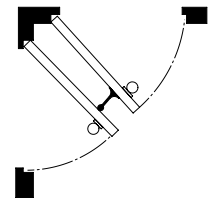

### 273W

#### Curved Roller Bumper

- Certification: Meets ANSI A156.16 for L12213  
 Projection: 2-21/32" (67 mm)  
 Materials: Cast brass with grey rubber roller  
 Finishes: US3, US4, US10, US10B, US26, US26D  
 Fasteners: Three (3) #10 x 1" FPHWS and three (3) plastic anchors  
 Notes:
  - Used when two doors swing into each other at odd angles
  - Prevents damage to the door and door hardware

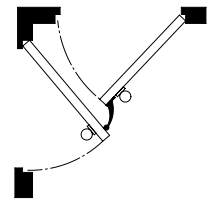



## FLOOR STOPS & HOLDERS



### 241F | BL241F

#### Dome Stop - Low

Certification: Meets ANSI A156.16 for L02142  
 Base Diameter: 1-11/16" (43 mm)  
 Base Thickness: 1/8" (3.2 mm)  
 Overall Height: 1" (25 mm)  
 Materials: Cast brass with grey rubber bumper  
 Finishes: US3, US4, US5, US9, US10, US10B, US15, US15A, US19, US26, US26D  
 Fasteners: One (1) #14 x 1-1/2" FPHWS, one (1) 1/4-20 x 3/4" FPHMS, one (1) 1/4-20 lead anchor, and one (1) plastic anchor

- Notes:
- To be used independently or in conjunction with 246B
  - For use when no threshold is used (door not undercut)
  - For use with wood or concrete floors
  - BL241F is 241F case quantity 50



### 242F

#### Dome Stop - Universal

Certification: Meets ANSI A156.16 for L02162  
 Base Diameter: 1-11/16" (43 mm)  
 Base Thickness: 7/32" (5.5 mm)  
 Overall Height: 1-5/8 (41 mm)  
 Materials: Brass with grey rubber bumper  
 Finishes: US3, US4, US10B, US15, US26, US26D  
 Fasteners: One (1) #14 x 1-1/2" FPHWS, one (1) 1/4-20 x 3/4" FPHMS, one (1) 1/4-20 lead anchor, and one (1) plastic anchor

- Notes: For use with wood or concrete floors



### 243F | BL243F

#### Dome Stop - High

Certification: Meets ANSI A156.16 for L02162  
 Base Diameter: 1-11/16" (43 mm)  
 Base Thickness: 7/16" (11 mm)  
 Overall Height: 1-9/32" (33 mm)  
 Materials: Cast brass with grey rubber bumper  
 Finishes: US3, US4, US5, US9, US10, US10B, US15, US15A, US19, US26, US26D  
 Fasteners: One (1) #14 x 1-1/2" FPHWS, one (1) 1/4-20 x 1-1/4" FPHMS, one (1) 1/4-20 lead anchor, and one (1) plastic anchor

- Notes:
- For use with thresholds or undercut doors
  - For use with wood or concrete floors
  - BL243F is 243F case quantity 50



### 244F

#### Cast Floor Stop

Certification: Meets ANSI A156.16 for L02141  
 Base: 1-3/4" x 4" (45 mm x 102 mm)  
 Base Thickness: 5/32" (4 mm)  
 Overall Height: 1" (25 mm)  
 Materials: Cast brass with grey rubber bumper  
 Finishes: US3, US4, US10, US10B, US26, US26D  
 Fasteners: Two (2) #14 x 1-1/2" FPHWS, two (2) 1/4-20 x 3/4" FPHMS, two (2) 1/4-20 lead anchor, and two (2) plastic anchor

- Notes:
- Heavy duty - for use in high traffic areas
  - For use when no thresholds are used (door not undercut)
  - For use with wood or concrete floors

## FLOOR STOPS & HOLDERS



### 245F

#### Cast Floor Stop

Certification: Meets ANSI A156.16 for L02161  
 Base: 1-3/4" x 4" (45 mm x 102 mm )  
 Base Thickness: 1/2" (13 mm)  
 Overall Height: 1-5/16" (33 mm)  
 Materials: Cast brass with grey rubber bumper  
 Finishes: US3, US4, US10, US10B, US26, US26D  
 Fasteners: Two (2) #14 x 1-1/2" FPHWS, two (2) 1/4-20 x 1-1/4" FPHMS, two (2) 1/4-20 lead anchor, and two (2) plastic anchor  
 Notes:
 

- Heavy duty - for use in high traffic areas
- For use with thresholds and undercut doors
- For use on wood or concrete floors



### 246B

#### Dome Stop Riser Plate

Diameter: 1-3/4" (45 mm)  
 Thickness: 3/8" (10 mm)  
 Fasteners: One (1) 1/4-20 x 1" FPHMS  
 Materials: Cast brass  
 Finishes: US3, US4, US10, US10B, US15, US15A, US19, US26, US26D  
 Notes: For use with 241F on undercut doors, doors with thresholds, and carpeted flooring



### 248F

#### Modern Style Universal Stop

Base Diameter: 1-7/16" (37 mm)  
 Height: 1-1/2" (38 mm)  
 Materials: Brass with black rubber bumper  
 Finishes: US26D  
 Fasteners: One (1) #12 x 1-1/4" FPHWS, one (1) plastic anchor, one (1) 1/4-20 x 1" FPHMS, and one (1) 1/4-20 lead anchor



### 248G

#### Modern Style Universal Stop

Base Diameter: 1-7/16" (37 mm)  
 Height: 1-1/2" (38 mm)  
 Materials: Brass with grey rubber bumper  
 Finishes: US26D  
 Fasteners: One (1) #12 x 1-1/4" FPHWS with plastic anchor and one (1) 1/4-20 x 1" FPHMS with lead anchor



### 249F

#### L-Shaped Floor Stop

Base: 1" x 2-1/2" x 7/32" thick (25 mm x 64 mm x 6 mm)  
 Base Thickness: 1/4" (6 mm)  
 Overall Height: 2-5/8" (67 mm)  
 Stop face: Resilient black rubber  
 Materials: Steel  
 Fasteners: Two (2) #14 x 1-1/2" FPHWS and two (2) plastic anchors  
 Notes: 1-1/2" (38 mm) max door to floor clearance





## FLOOR STOPS & HOLDERS



### 252F

#### Floor Stop

- Certification: Meets ANSI A156.16 for L02131  
 Base: 1-9/16" x 2-1/2" (40 mm x 64 mm)  
 Overall Height: 2-11/16" (68 mm)  
 Materials: Cast brass with black rubber bumper  
 Finishes: US3, US10, US10B, US15, US15A, US19, US26, US26D  
 Fasteners: One (1) #14 x 1-1/2" FPHWS, one (1) 1/4-20 x 3/4" FPHMS, one (1) 5/16-18 lead anchor, one (1) 1/4-20 lead anchor, one (1) plastic anchor, one (1) 5/16-18 x 2-1/2" threaded stud, and one (1) 5/16-18 x 2-1/2" combo threaded stud
- Notes:
- Heavy duty - for use in high traffic areas
  - For use on wood or concrete floors
  - 2" (51 mm) max door to floor clearance



### 257F

#### Floor Stop

- Certification: Meets ANSI A156.16 for L02131  
 Base: 1-9/16" x 2-15/32" (40 mm x 63 mm)  
 Overall Height: 2" (51 mm)  
 Materials: Cast brass with black rubber bumper  
 Finishes: US3, US10, US10B, US15, US15A, US19, US26, US26D  
 Fasteners: One (1) #14 x 1-1/2" FPHWS, one (1) 1/4-20 x 3/4" FPHMS, one (1) 5/16-18 lead anchor, one (1) 1/4-20 lead anchors, one (1) plastic anchor, one (1) 5/16-18 x 2-1/2" threaded stud, and one (1) 5/16-18 x 2-1/2" combo threaded stud
- Notes:
- 1-3/8" (35 mm) max door to floor clearance
  - Heavy duty - for use in high traffic areas
  - For use on wood or concrete floors



### 258F

#### Floor Stop and Holder

- Certification: Meets ANSI A156.16 for L01371  
 Base: 1-9/16" x 2-15/32" (40 mm x 63 mm)  
 Height: 3" (76 mm)  
 Keeper: 1" x 2" (25 mm x 51 mm)  
 Materials: Cast brass with black rubber bumper  
 Finishes: US3, US10, US10B, US15, US26, US26D  
 Fasteners: Two (2) #10 x 1" FPHWS, one (1) 1/4-20 x 3/4" FPHMS, one (1) 5/16-18 lead anchor, one (1) 1/4-20 lead anchors, and one (1) 5/16-18 x 2-1/2" threaded stud
- Notes:
- 1-3/8" (35 mm) max door to floor clearance
  - Heavy duty - for use in high traffic areas
  - For use on concrete floors
  - Manual holder ideal for interior and exterior applications
  - Unit functions as a stop, but can serve as a "Hold Open" when hook is manually engaged

## FLOOR STOPS & HOLDERS



### 259F

#### Tri Base Floor Stop

- Certification: Meets ANSI A156.16 for L02121  
 Base: 2-1/2" wide x 1-9/16" deep (64 mm x 40 mm)  
 Overall Height: 1-11/16" (43 mm)  
 Material: Cast brass with grey rubber bumper  
 Finishes: US3, US4, US10, US10B, US26, US26D  
 Fasteners: Three (3) #10 x 1-1/4" FPHWS, three (3) plastic anchors, three (3) 10-32 x 3/4" FPHMS, and three (3) 10-32 lead anchor
- Notes:
- 1/2" (13 mm) max door to floor clearance
  - Heavy duty - for use in high traffic areas
  - For use on wood or concrete floors



### 259H

#### Tri Base Floor Stop - Tall

- Certification: Meets ANSI A156.16 for L02121  
 Base: 2-1/2" wide x 1-9/16" deep (64 mm x 40 mm)  
 Overall Height: 2-1/4" (57 mm)  
 Materials: Cast brass with grey rubber bumper  
 Finishes: US3, US4, US10, US10B, US26, US26D  
 Fasteners: Three (3) #10 x 1-1/4" FPHWS, three (3) plastic anchor, three (3) 10-32 x 3/4" FPHMS, and three (3) 10-32 lead anchors
- Notes:
- 1" (25 mm) max door to floor clearance
  - Heavy duty - for use in high traffic areas
  - For use on wood or concrete floors



### 267F

#### Cast Floor Stop

- Certification: Meets ANSI A156.16 for L02131  
 Base Diameter: 2-1/4" (57 mm)  
 Overall Height: 3-1/8" (80 mm)  
 Materials: Cast brass with black rubber bumper  
 Finishes: US3, US10, US10B, US15, US15A, US19, US26, US26D  
 Fasteners: One (1) #10 x 1" OPHWS, one (1) plastic anchor, one (1) 5/16-18 lead anchor, one (1) 5/16-18 x 2-1/2" threaded stud, and one (1) 5/16-18 x 2-1/2" combo threaded stud
- Notes:
- 2-3/8" (60 mm) max door to floor clearance
  - Heavy duty - for use in high traffic areas
  - For use on concrete floors



### 267S

#### Cast Floor Stop

- Certification: Meets ANSI A156.16 for L02121  
 Base Diameter: 2-1/4" (57 mm)  
 Overall Height: 3-1/8" (80 mm)  
 Materials: Cast brass with black rubber bumper  
 Finishes: US3, US10, US10B, US15, US15A, US19, US26, US26D  
 Fasteners: Three (3) #10 x 1" OPHWS and three (3) plastic anchors
- Notes:
- 2-3/8" (60 mm) max door to floor clearance
  - Heavy duty - for use in high traffic areas
  - For use on wood floors





## FLOOR STOPS & HOLDERS



### 268F

#### Cast Floor Stop and Holder

- Certification: Meets ANSI A156.16 for L01371  
 Base Diameter: 2-1/4" (57 mm)  
 Height: 3-19/32" (91 mm)  
 Keeper: 25/32" x 1-1/2" (20 mm x 38 mm)  
 Materials: Cast brass with black rubber bumper  
 Finishes: US3, US10, US10B, US15, US15A, US19, US26, US26D  
 Fasteners: Three (3) #10 x 1" OPHWS, one (1) plastic anchor, one (1) 5/16-18 lead anchor, and one (1) 5/16-18 x 2-1/2" threaded stud
- Notes:
- 2-1/2" (64 mm) max door to floor clearance
  - Heavy duty - for use in high traffic areas
  - For use on concrete floors
  - Manual holder ideal for interior and exterior applications
  - Unit functions as a stop, but can serve as a "Hold Open" when hook is manually engaged



### 268S

#### Cast Floor Stop and Holder

- Certification: Meets ANSI A156.16 for L01361  
 Base Diameter: 2-1/4" (57 mm)  
 Height: 3-19/32" (91 mm)  
 Keeper: 25/32" x 1-1/2" (20 mm x 38 mm)  
 Materials: Cast brass with black rubber bumper  
 Finishes: US3, US10, US10B, US15, US15A, US19, US26, US26D  
 Fasteners: Five (5) #10 x 1" OPHWS and three (3) plastic anchors
- Notes:
- 2-1/2" (64 mm) max door to floor clearance
  - Heavy duty - for use in high traffic areas
  - For use on wood floors
  - Manual holder ideal for interior and exterior applications
  - Unit functions as a stop, but can serve as a "Hold Open" when hook is manually engaged



### 269F

#### Heavy Duty Floor Stop

- Certification: Exceeds the criteria set forth for a 300-pound impact test (Report #91-04-01646)  
 Bumper Diameter: 2" (51 mm)  
 Bumper Height: 1-1/2" (38 mm)  
 Steel Bolt: 5/8 - 11 x 2-1/2" thread  
 Materials: Black rubber (fire-resistant)
- Notes:
- Designed for high vandalism areas
  - Ideal for prisons where floor stops are required
  - Grouted in concrete to eliminate exposed screws



## FLOOR STOPS & HOLDERS



### 269T Heavy Duty Floor Stop

Certification:	Exceeds the criteria set forth for a 300-pound impact test (Report #91-04-01646)
Bumper Diameter:	2" (51 mm)
Bumper Height:	3-1/2" (89 mm)
Steel Bolt:	5/8 – 11 x 2-1/2" thread
Materials:	Black rubber (fire-resistant)
Notes:	<ul style="list-style-type: none"> <li>• Designed for high vandalism areas</li> <li>• Ideal for prisons where floor stops are required</li> <li>• Grouted in concrete to eliminate exposed screws</li> </ul>



### 326F Automatic Floor Stop and Holder

Certification:	Meets ANSI A156.16 for L01301
Holder Projection:	1-15/16" (49 mm)
Holder Base:	3-1/16" x 3-1/2" (78 mm x 89 mm)
Floor Strike:	2" x 4-3/32" (51 mm x 104 mm)
Strike Height:	1-1/4" (32 mm)
Max Door to Floor Clearance:	1/2" (13 mm) or less
Materials:	Cast brass
Finishes:	US3, US10, US10B, US26, US26D
Fasteners:	Three (3) #14 x 1-1/2" FPHWS, three (3) 1/4-20 x 3/4" FPHMS, three (3) 1/4-20 lead anchors, four (4) 12-24 x 1" TPHMS, and four (4) #12 x 1" TPHWS
Notes:	<ul style="list-style-type: none"> <li>• For use on wood or metal doors and wood or concrete floors</li> <li>• Ideal for heavy traffic situations that require frequent hold open</li> <li>• Firm pull releases holding mechanism</li> <li>• Holder has vertical adjustment once mounted on the door</li> </ul>



### 327F Automatic Floor Stop and Holder

Certification:	Meets ANSI A156.16 for L01301
Holder Projection:	1-15/16" (49 mm)
Holder Base:	3-1/16" x 3-1/2" (78 mm x 89 mm)
Floor Strike:	2-3/16" x 4-1/8" (56 mm x 105 mm)
Strike Height:	1-3/4" (44 mm)
Max Door to Floor Clearance:	9/16" to 1-1/16" (14 mm to 27 mm)
Materials:	Cast brass
Finishes:	US3, US10, US10B, US26, US26D
Fasteners:	Three (3) #14 x 1-1/2" FPHWS, three (3) 1/4-20 x 3/4" FPHMS, three (3) 1/4-20 lead anchors, four (4) 12-24 x 1" TPHMS, and four (4) #12 x 1" TPHWS
Notes:	<ul style="list-style-type: none"> <li>• For use on wood or metal doors and wood or concrete floors</li> <li>• Ideal for heavy traffic situations that require frequent hold open</li> <li>• Firm pull releases holding mechanism</li> <li>• Holder has vertical adjustment once mounted on the door</li> </ul>





## FLOOR STOPS & HOLDERS



### 328F

#### Automatic Floor Stop and Holder

- Certification: Meets ANSI A156.16 for L01301  
 Holder Projection: 1-15/16" (49 mm)  
 Holder Base: 3-1/16" x 3-1/2" (78 mm x 89 mm)  
 Floor Strike: 2-3/16" x 4-1/8" (56 mm x 105 mm)  
 Strike Height: 2-1/4" (57 mm)  
 Max Door to Floor Clearance: 1-1/8" to 1-9/16" (29 mm to 40 mm)  
 Materials: Cast brass  
 Finishes: US3, US10, US10B, US26, US26D  
 Fasteners: Three (3) #14 x 1-1/2" FPHWS, three (3) 1/4-20 x 3/4" FPHMS, three (3) 1/4-20 lead anchors, four (4) 12-24 x 1" TPHMS, and four (4) #12 x 1" TPHWS
- Notes:
- For use on wood or metal doors and wood or concrete floors
  - Ideal for heavy traffic situations that require frequent hold open
  - Firm pull releases holding mechanism
  - Holder has vertical adjustment once mounted on the door



### 329F

#### Automatic Floor Stop and Holder

- Certification: Meets ANSI A156.16 for L01301  
 Holder Projection: 1-15/16" (49 mm)  
 Holder Base: 3-1/16" x 3-1/2" (78 mm x 89 mm)  
 Floor Strike: 2-3/16" x 4-1/8" (56 mm x 105 mm)  
 Strike Height: 2-3/4" (70 mm)  
 Max Door to Floor Clearance: 1-5/8" to 2-1/16" (41 mm to 52 mm)  
 Materials: Cast brass  
 Finishes: US3, US10, US10B, US26, US26D  
 Fasteners: Three (3) #14 x 1-1/2" FPHWS, three (3) 1/4-20 x 3/4" FPHMS, three (3) 1/4-20 lead anchors, four (4) 12-24 x 1" TPHMS, and four (4) #12 x 1" TPHWS
- Notes:
- For use on wood or metal doors and wood or concrete floors
  - Ideal for heavy traffic situations that require frequent hold open
  - Firm pull releases holding mechanism
  - Holder has vertical adjustment once mounted on the door

## KICK DOWN DOOR STOPS



### 270C

#### Kick Down Door Holder

- Certification: Meets ANSI A156.16 for L71382  
 Base: 1-7/16" x 2-1/8" (37 mm x 54 mm)  
 Arm: 3-13/16" (97 mm)  
 Materials: Cast iron with rubber tip  
 Finishes: S1 - Sprayed Aluminum, S2 - Sprayed Brass, S3 - Sprayed Bronze  
 Fasteners: Four (4) #6 x 3/4" OPH tapping screws  
 Notes:
  - Provides simple hold and release with a touch of the foot
  - 2-1/4" (57 mm) max door to floor clearance



### 270D

#### Kick Down Door Holder

- Certification: Meets ANSI A156.16 for L01381  
 Base: 1-19/32" x 1-25/32" (41 mm x 45 mm)  
 Arm: 3-1/2" (89 mm)  
 Materials: Cast brass with rubber tip  
 Finishes: US3, US10, US10B, US15, US15A, US19, US26, US26D  
 Fasteners: Three (3) #6 x 3/4" OPHWS  
 Notes:
  - Provides simple hold and release with a touch of the foot
  - 2-1/4" (57 mm) max door to floor clearance



### 270R

#### Replacement Rubber Tip

- Materials: Rubber  
 Notes:
  - For use with 270D and 271D
  - Sold in packs of 10



### 270CR

#### Replacement Rubber Tip

- Materials: Rubber  
 Notes:
  - For use with 270C
  - Sold in packs of 6



### 271D

#### Kick Down Door Holder

- Certification: Meets ANSI A156.16 for L01381  
 Base: 1-19/32" x 1-25/32" (41 mm x 45 mm)  
 Arm: 4-7/16" (87 mm)  
 Materials: Cast brass with rubber tip  
 Finishes: US3, US10, US10B, US26, US26D  
 Fasteners: Three (3) #6 x 3/4" OPHWS  
 Notes:
  - Provides simple hold and release with a touch of the foot
  - 3-1/4" (83 mm) max door to floor clearance



## SURFACE BOLTS



### 275D | 276D

#### Surface Bolt

Certification: Meets ANSI A156.16 for L04161  
 Overall Projection: 1-3/8" (35 mm)  
 Overall Width: 2-1/32" (52 mm)  
 Bar: 3/4" x 1/4" (19 mm x 6 mm) thick  
 Length: 275D - 8" (203 mm)  
 276D - 12" (305 mm)  
 Throw: 1" (25 mm)  
 Materials: Steel  
 Finishes: US3, US10, US10B, US26D  
 Fasteners: Eight (8) #10 x 1-1/4" FPHWS and eight (8) 10-24 x 1" undercut FPHMS

Notes:

- Mortise bottom strike and universal top strike included
- Strong tension springs prevent creep
- UL listed for use on inactive leaf of a pair of 3-HR labeled fire doors



### 278D

#### Surface Bolt

Bolt Length: 6" (152 mm)  
 Bolt Width: 7/16" (11 mm)  
 Bolt Throw: 31/32" (25 mm)  
 Base Width: 19/32" (15 mm)  
 Knob Diameter: 1/2" (13 mm)  
 Projection: 3/4" (19 mm)  
 Materials: Brass  
 Finishes: US3, US10B, US26D  
 Fasteners: Four (4) #5 x 5/8" FPHWS

Notes:

- Mortise and universal strikes included
- Concealed screw design enhances appearance and security
- Permanent stop prevents bolt disengagement from track



### 279D

#### Surface Bolt

Length: 4" (102 mm)  
 Width: 1-11/16" (43 mm)  
 Throw: 3/8" (10 mm)  
 Half Round Bolt Size: 5/8" (16 mm)  
 Projection: 1-1/4" (32 mm)  
 Knob Diameter: 29/32" (23 mm)  
 Materials: Brass  
 Finishes: US3, US10, US10B, US26D  
 Fasteners: Twelve (12) #6 x 3/4" FPHWS

Notes: Mortise and universal strikes included

## FLUSH BOLTS & COORDINATING DEVICES



### 280X Dust Proof Strike

- Certification: Meets ANSI A156.16 for L04021
- Face Plate: 1-7/16" x 2-29/32" x 1/8" depth (37 mm x 74 mm x 3 mm)
- Barrel Diameter: 1" (25 mm)
- Barrel Depth: 2-3/16" (56 mm)
- Plunger Diameter: 3/4" (19 mm)
- Materials: Brass
- Finishes: US3, US4, US9, US10, US10B, US15, US15A, US19, US26, US26D
- Fasteners: Two (2) #8 x 1" FPHWS, two (2) plastic anchors, and spanner wrench
- Notes:
  - Packed unassembled with plate, strike, fasteners, and spanner wrench
  - May be used with carpet or threshold application by omitting face plate
  - Designed for use with the bottom bolt of a flushbolt set
  - Spring loaded plunger returns to floor or threshold level anytime flushbolt is retracted, eliminating the need to clean out the bottom strike



### 281D Slide Flush Bolt

- Certification: Meets ANSI A156.16 for L04201
- Faceplate: 3/4" x 6" (19 mm x 153 mm)
- Bolt Diameter: 1/2" (13 mm)
- Bolt Throw: 1" (25 mm)
- Bolt Backset: 7/16" (11 mm)
- Strike: 7/8" x 1-3/4" (22 mm x 45 mm)
- Materials: Brass, bronze faceplate with steel components
- Finishes: US3, US4, US5, US10, US10B, US15, US15A, US19, US26, US26D
- Fasteners: Four (4) #6 x 3/4" FPHWS
- Notes: Double action spring design provides automatic holding of bolt in projected or retracted position



### 282D Manual Flush Bolt

- Certification:
  - Fits ANSI A115 door and frame prep
  - Meets ANSI A156.16 for L14251
- Face Plate: 1" x 6-3/4" (25 mm x 172 mm)
- Bolt Head: 1/2" (13 mm) square
- Bolt Throw: 3/4" (19 mm)
- Standard Rod Length: 12" (305 mm) (center of face to corner of door)
- Bolt Backset: 3/4" (19 mm)
- Mortise Strike: 15/16" x 2-1/4" (24 mm x 57 mm)
- Materials: Brass faceplate with steel components
- Finishes: US3, US4, US5, US9, US10, US10B, US15, US15A, US19, US26, US26D
- Fasteners: Eight (8) #8 x 3/4" combo screws; eight (8) #8 x 1-1/2" combo screws
- Notes:
  - For use on hollow metal/fire-rated doors
  - Non-handed
  - Bolt head rods are adjustable
  - Sold in increments of two
  - 3 hour fire rating for metal doors up to 4 feet wide by 10 feet tall
  - 282S strike plate bag and 282P bolt head available
  - Specify 282R for optional rod length of 18" (457 mm), 25" (635 mm), or 30" (762 mm) (bolt head not included)





## FLUSH BOLTS & COORDINATING DEVICES



### 283D

#### Manual Flush Bolt

Certification: Meets ANSI A156.16 for L14261  
 Face Plate: 1" x 6-25/32" (25 mm x 172 mm)  
 Bolt Head: 1/2" (13 mm) square  
 Bolt Throw: 3/4" (19 mm)  
 Bolt Backset: 3/4" (19 mm)  
 Mortise Strike: 15/16" x 2-1/4" (24 mm x 57 mm)  
 Materials: Brass faceplate with steel components  
 Finishes: US3, US4, US5, US9, US10, US10B, US15, US15A, US19, US26, US26D  
 Fasteners: Eight (8) #8 x 3/4" combo screws  
 Notes:

- For use on wood composite/ fire-rated doors
- Non-handed
- Bolt head rods are adjustable
- 1-1/2 hour fire rating for wood doors up to 4 feet wide by 10 feet tall



### 291D

#### Automatic Flush Bolt Set for Wood Covered Composite Doors

Certification: B, C, D, and E Label  
 ANSI A156.3 Type #25  
 Face Plate: 1" x 8-1/2" (25 mm x 216 mm)  
 Bolt Head: 1/2" (13 mm) square  
 Bolt Throw: 3/4" (19 mm)  
 Bolt Backset: 3/4" (19 mm)  
 Mortise Strike: 15/16" x 2-1/4" (24 mm x 57 mm)  
 Materials: Stainless steel and brass with steel components  
 Finishes: US3, US4, US10, US10B, US15, US32, US32D  
 Fasteners: Six (6) #8 x 1" combo screws, three (3) #10 x 1" SMS, and two (2) plastic anchors

- Notes:
- Thermal lock automatically locks inactive door under high fire/heat conditions
  - 280X dust proof strikes are recommended for use with these sets
  - Used in pairs at top and bottom of inactive door
  - Fully automatic – bolts retract when active door is opened; bolts extend when active door is closed
  - Non-handed
  - Bolt head rods are adjustable
  - 1-1/2 hour fire rating for wood doors up to 4 feet wide by 9 feet tall

## FLUSH BOLTS & COORDINATING DEVICES

### 292D

#### Automatic Flush Bolt Set for Metal Doors

Certification: A, B, C, D, and E Label  
ANSI A156.3 Type #25

Face Plate: 1" x 6-3/4" (27 mm x 172 mm)

Bolt Head: 1/2" (13 mm) square

Bolt Throw: 3/4" (19 mm)

Bolt Backset: 3/4" (19 mm)

Mortise Strike: 15/16" x 2-1/4" (24 mm x 57 mm)

Materials: Stainless steel and brass with steel components

Finishes: US3, US4, US10, US10B, US15, US32, US32D

Fasteners: Ten (10) #8 x 1" combo screws

Notes:

- Thermal lock automatically locks inactive door under high fire/heat conditions
- 280X dust proof strikes are recommended for use with these sets
- Used in pairs at top and bottom of inactive door
- Fully automatic – bolts retract when active door is opened; bolts extend when active door is closed
- Non-handed
- Bolt head rods are adjustable
- 3-hour fire rating for metal doors up to 4 feet wide by 9 feet tall



### 293D

#### Constant-Latching Flush Bolt Set for Inactive Metal Doors

Certification: A, B, C, D, and E Label  
ANSI A156.3 Type #27

Face Plate: 1" x 6-3/4" (25 mm x 172 mm)

Bolt Head: 1/2" (13 mm) square

Bolt Throw: 3/4" (19 mm)

Bolt Backset: 3/4" (19 mm)

T- Strike: 1-1/8" x 2-3/4" (28 mm x 70 mm)

Materials: Stainless steel and brass with steel components

Finishes: US3, US4, US10, US10B, US15, US32, US32D

Fasteners: Eight (8) #8 x 1" combo screws

Notes:

- Thermal lock automatically locks inactive door under high fire/heat conditions
- 280X dust proof strikes are recommended for use with these sets
- Consists of one 292S and one 293S for two point latching
- Inactive door remains latched until the active door is opened, releasing the automatic bottom bolt - Top bolt can be manually released by pressing plunger - Inactive door will relatch automatically when closed
- Non-handed
- Bolt head rods are adjustable
- 3-hour fire rating for metal doors up to 4 feet wide by 9 feet tall





## FLUSH BOLTS & COORDINATING DEVICES



### 294D

#### Constant-Latching Flush Bolt Set for Inactive Wood Covered Composite Doors

- Certification: B, C, D, and E Label  
ANSI A156.3 Type #27
- Face Plate: 1" x 8-1/2" (25 mm x 216 mm)
- Bolt Head: 1/2" (13 mm) square
- Bolt Throw: 3/4" (19 mm)
- Bolt Backset: 3/4" (19 mm)
- T- Strike: 1-1/8" x 2-3/4" (28 mm x 70 mm)
- Materials: Stainless steel and brass with steel components
- Finishes: US3, US4, US10, US10B, US15, US32, US32D
- Fasteners: Four (4) #8 x 1" combo screws, three (3) #10 x 1" SMS, and two (2) plastic anchors
- Notes:
- Thermal lock automatically locks inactive door under high fire/heat conditions
  - 280X dust proof strikes are recommended for use with these sets
  - May be used on doors 4 ft. wide and 9 ft. high
  - Consists of one 291S and one 294S for two point latching
  - Inactive door remains latched until the active door is opened, releasing the automatic bottom bolt - Top bolt can be manually released - Inactive door will relatch automatically when closed
  - Non-handed
  - Bolt head rods are adjustable
  - 1-1/2 hour fire rating for wood doors up to 4 feet wide by 9 feet tall



### 295M

#### Automatic Flush Bolt Set with Fire Bolt for Metal Doors

- Certification: ANSI/BHMA 156.3 Type #25
- Face Plate: 1" x 6-3/4" (25 mm x 172 mm)
- Bolt Head: 1/2" (13 mm) square
- Bolt Throw: 3/4" (19 mm)
- Bolt Backset: 3/4" (19 mm)
- Mortise Strike: 15/16" x 2-1/4" (24 mm x 57 mm)
- Materials: Stainless steel and brass with steel components
- Finishes: US3, US4, US10, US10B, US15, US32, US32D
- Fasteners: Ten (10) #8 x 1" combo screws
- Notes:
- Fire bolt is activated at 230° Fahrenheit projecting into active door locking leaves together - This combination eliminates the bottom flushbolt and eliminates floor preparation
  - Fully automatic – Bolt retracts when active door is opened - Bolt extends when active door is closed
  - Non-handed
  - Bolt head rods are adjustable
  - 3-hour fire rating for metal doors up to 4 feet wide by 9 feet tall





## FLUSH BOLTS & COORDINATING DEVICES



### 295W

#### Automatic Flush Bolt Set with Fire Bolt for Wood Doors

- Certification: ANSI/BHMA 156.3 Type #25  
 Face Plate: 1" x 8-1/2" (25 mm x 216 mm)  
 Bolt Head: 1/2" (13 mm) square  
 Bolt Throw: 3/4" (19 mm)  
 Bolt Backset: 3/4" (19 mm)  
 Mortise Strike: 15/16" x 2-1/4" (24 mm x 57 mm)  
 Materials: Stainless steel and brass with steel components  
 Finishes: US3, US4, US10, US10B, US15, US32, US32D  
 Fasteners: Six (6) #8 x 1" combo screws, three (3) #10 x 1" SMS, and two (2) plastic anchors
- Notes:
- Fire bolt is activated at 230° Fahrenheit projecting into active door locking leaves together - This combination eliminates the bottom flushbolt and eliminates floor preparation
  - Fully automatic – Bolt retracts when active door is opened - Bolt extends when active door is closed
  - Non-handed
  - Bolt head rods are adjustable
  - 20-min fire rating for wood doors up to 4 feet wide by 9 feet tall



### 296W

#### Automatic Flush Bolt Set for Wood Doors

- Certification: ANSI/BHMA 156.3 Type #25  
 Face Plate: 1-1/8" x 2-1/4" (29 mm x 57 mm)  
 Bolt Head: 1/2" (13 mm) diameter  
 Bolt Throw: 3/4" (19 mm)  
 Bolt Backset: 1-1/2" (39 mm)  
 Materials: Stainless steel and brass with steel components  
 Finishes: US3, US4, US10, US10B, US15, US32, US32D  
 Fasteners: Four (4) #8 x 1" SMS, two (2) #8 x 3/4" combo screws, two (2) plastic anchors
- Strike: 1-1/8" x 2-1/4" (29 mm x 57 mm)
- Notes:
- Non-handed
  - ADA compliant
  - Ideal for wood veneer doors
  - Only two (2) 1-1/8" diameter holes needed for easier door preparation
  - Opening active door retracts top and bottom bolts
  - Smaller profile adds stability to the door
  - 1-1/2 hour fire rating for doors up to 4 feet wide by 9 feet tall





## FLUSH BOLTS & COORDINATING DEVICES



### 297C Carry Bar

Certification:  
Projection:  
Base:  
Materials:  
Finishes:  
Fasteners:  
Notes:

ANSI/BHMA A156.3 Type #27

25/32" (20 mm)

1-3/4" x 2-1/4" (45 mm x 57 mm)

Brass and stainless steel

USP, US3, US10, US10B, US15, US32, US32D

Two (2) 12-24 x 3/4" PPHMS w/ sex nuts

- Used when it is possible for the inactive door to be opened before the active door
- For use on pairs of doors with astragals
- For use in conjunction with a 297D or 298D coordinator
- Prevents damage to the doors and other hardware
- Carry bar is not required when the inactive door is equipped with automatic or self-latching flushbolts
- Non-handed



### 297D Coordinating Device

Certification:  
Base:  
Maximum Astragal Overlap:  
Stop Height:  
Materials:  
Finishes:  
Fasteners:

ANSI/BHMA A156.3 Type #21A

1-5/8" x 5/8" (41 mm x 16 mm)

1" (25 mm)

5/8" (16 mm)

Steel

Black Prime Coat

Seven (7) 12-24 x 1-1/4" TPHMS and four (4) #8 x 1" FPH combo screws

Notes:

- For use with overall frame widths 60" (1524 mm), 72" (1829 mm), or 96" (2438 mm), consult Hager Customer Service if overall frame width is different than our stock sizes
- Coordinating device is 52" (1321 mm) long for all stock sizes 60" (1524 mm), 72" (1829 mm), or 96" (2438 mm)
- Filler bar is cut to length by factory to match customers overall frame width
- Non-handed
- Designed for use on pairs of doors when one door needs to close before the other
- Active door lever, located nearest to the active stop, holds the active door open until the trigger mechanism is released by the closing of the inactive leaf
- Coordinator may not span the entire length of stop, 297F filler bar may be needed to fill up the extra space
- Compatible with flushbolts
- Optional mounting brackets 297M and 297N may be used when mounting other soffit applied hardware
- For use with active door widths 30" (762 mm) – 48" (1219 mm)
- If active and inactive doors are unequal in length, consult Hager Customer Service for proper sizing
- Do not use spring hinges with coordinating device

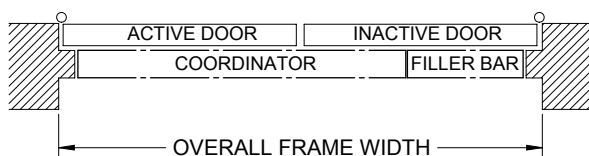

## FLUSH BOLTS & COORDINATING DEVICES



### 297F

#### Filler Bar

Stop Height: 5/8" (16 mm)  
 Material: Steel  
 Finishes: Black prime coat  
 Length: 18-5/8" (473 mm) (for jamb opening widths 52" – 72");  
 42-5/8" (1082 mm) (for jamb opening widths 73" – 96")  
 Notes: For use with 297D coordinator



### 297M

#### Mounting Bracket

Jamb Depth: 4-3/4" (121 mm)  
 Stop Height: 5/8" (16 mm)  
 Material: Aluminum  
 Finishes: Black prime coat  
 Fasteners: Four (4) 12-24 x 2" FPHMS and four (4) 1/4-20 x 1/2" FPHMS  
 Notes:
 

- For use with 297D coordinator
- For soffit width 1-3/8" (35 mm) - 2-3/8" (60 mm)
- Allows soffit mounted hardware to be properly installed without damaging the coordinator, such as a parallel arm closer or a non-fire-rated surface vertical rod strike



### 297N

#### Mounting Bracket

Stop Height: 5/8" (16 mm)  
 Material: Aluminum  
 Finishes: Black prime coat  
 Fasteners: Four (4) 12-24 x 2" FPHMS and four (4) 1/4-20 x 1/2" FPHMS  
 Notes:
 

- For use with 297D coordinator
- For soffit width 3" (76 mm) or greater
- Allows soffit mounted hardware to be properly installed without damaging the coordinator, such as a parallel arm closer or a non-fire-rated surface vertical rod strike



### 298D

#### Gravity Coordinator

Certification: ANSI A156.3 Type #21B  
 Base: 5-1/2" x 1-1/8" (140 mm x 29 mm)  
 Projection: 7" (178 mm)  
 Rail Height: 2-1/2" (64 mm) min  
 Materials: Cast brass with rubber roller and nylon cam roller  
 Finishes: US3, US10, US10B, US26D  
 Fasteners: Two (2) #12 x 1" OPHWS, two (2) #6 x 3/4" FPHWS, two (2) #8 x 3/4" TPHWS, and one (1) #6 x 3/4" FPHWS  
 Notes:
 

- Non-handed
- Recommended for use with flush top metal doors only
- Use automatic flush bolts only
- Use 297D if using self latching flush bolts
- Gravity arm and door bracket are adjustable on the job for ease of installation
- For use on pairs of doors with astragal on active door up to 4' (1219 mm) wide or with astragal on inactive door up to 3'-4" (1016 mm) wide or with astragal on both doors up to 2'-10" (864 mm) wide
- Maximum astragal overlap - 7/8" (22 mm)
- Do not use spring hinges with coordinating device





## LATCHES & PROTECTION PLATES



### 311H | 311L Push/Pull Latch

- Certification: ANSI A156.2 Closest Equivalent  
(Bored Latch - Series 4000 - Grade 2)
- Push & Pull Levers: 1-15/16" x 4-1/2" (49 mm x 114 mm)
- Escutcheons: 3-1/16" x 5" (78 mm x 127 mm)
- Projection: 2-5/8" (67 mm)
- Bolt Throw: 1/2" (13 mm)
- Bolt Diameter: 3/4" (19 mm)
- Backset:
  - 2-3/4" (70 mm) - Standard
  - 5" (127 mm) - Optional
- Strike (TEE) - standard: 1-1/8" x 2-3/4" (29 mm x 70 mm)
- Strike (ASA) - standard: 1-1/4" x 4-7/8" (32 mm x 124 mm)
- Door thickness: 1-3/4" (45 mm)
- Materials: Zinc and stainless steel
- Finishes: US26, US26D, US32, US32D
- Notes:
  - Non-handed
  - Engraving is optional
  - 311L is same as 311H but for use on lead lined doors

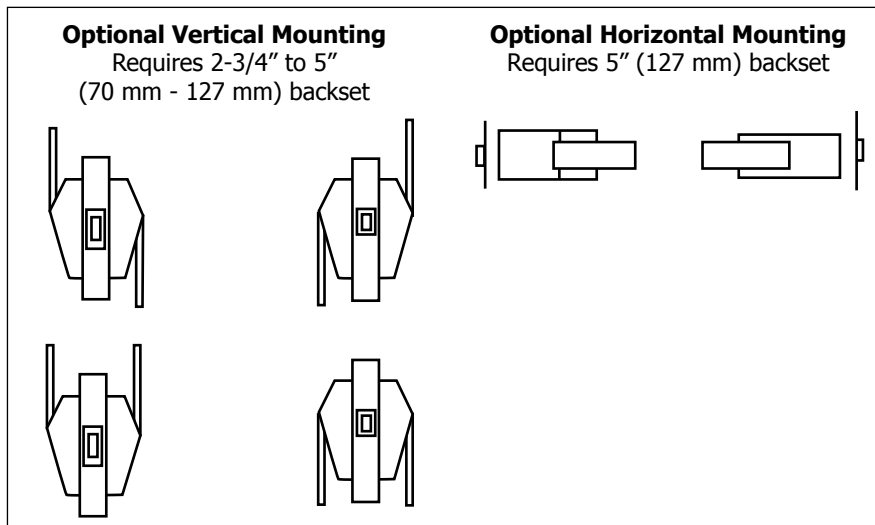

### 318D Roller Latch with Tee Strike

- Certification: Meets ANSI A156.16 for E09091
- Roller Faceplate: 1" x 3-3/8" (25 mm x 86 mm)
- Strike: 1-1/8" x 2-3/4" (29 mm x 70 mm)
- Strike Gauge: 0.171" (4.3 mm)
- Materials: Brass
- Finishes: US3, US4, US10, US10B, US15, US15A, US19, US26, US26D
- Fasteners: Two (2) #10 x 1-1/2" FPHWS, two (2) #8 x 1" FPHWS, and two (2) 8-32 x 3/4" FPHMS
- Notes:
  - Adjustable spring tension with nylon roller
  - Projection of roller is easily adjusted using screws on faceplate
  - Max projection of the roller is 3/8" (9.5 mm) allowing for variance in door and frame clearance

## LATCHES & PROTECTION PLATES



### 318S

#### Roller Latch with Stop

- Certification: Meets ANSI A156.16 for E0911  
 Roller Faceplate: 1-7/16" wide x 4-7/16" high x 11/16" angle (37 mm x 111 mm x 18 mm)  
 Strike: 1-1/8" x 2-1/4" (29 mm x 57 mm)  
 Strike Gauge: 0.171" (4.3 mm)  
 Materials: Brass  
 Finishes: US3, US4, US10, US10B, US15, US26, US26D  
 Fasteners: Two (2) #10 x 1-1/2" FPHWS and two (2) 8-32 x 3/4" FPHMS
- Notes:
- Adjustable spring tension with nylon roller
  - Projection of roller is easily adjusted using screws on faceplate
  - Max projection of the roller is 3/8" (9.5 mm) allowing for variance in door and frame clearance



### 320R

#### Roller Catch with Tee Strike

- Certification: Meets ANSI A156.16 for E0910  
 Roller Faceplate: 1-1/8" x 2-1/4" (29 mm x 57 mm)  
 Strike: 1-1/4" x 2-3/4" x 1/16" thick (32 mm x 70 mm x 1.5 mm)  
 Materials: Brass  
 Finishes: US3, US4, US10, US10B, US15, US26, US26D  
 Fasteners: Four (4) #8 x 1" FPHWS
- Notes:
- Adjustable spring tension with nylon roller
  - Projection of roller is adjusted by turning knurled knob on back of the latch
  - Max projection of the roller is 7/16" (11 mm) allowing for variance in door and frame clearance
  - For use with wood door and frame



### 321R

#### Adjustable Ball Catch with Strike

- Roller Faceplate: 1" x 2-1/8" (25 mm x 54 mm)  
 Strike: 1-1/2" x 2-1/8" (38 mm x 54 mm)  
 Strike Gauge: 0.050" (1.3 mm)  
 Materials: Brass with steel ball  
 Finishes: US3, US4, US10, US10B, US15, US15A, US19, US26D  
 Fasteners: Four (4) #6 FPHWS
- Notes:
- Adjustable threaded barrel compensates for various door clearances
  - Adjustable spring tension
  - For use with wood door and frame



### 323S

#### Three-Way Ball Catch

- Certification: Meets ANSI/BHMA 156.9.B13302  
 Body: 1/2" W x 2-3/16" H x 1/2" D  
 Strike:
  - 3/8" W x 1-3/8" H x 5/8" D
  - Plate type strike
 Materials: Brass with steel balls  
 Finish: US26D
- Notes:
- Adjustable spring tension is easily adjusted to suit field conditions
  - Body can be surface applied or mortised





## LATCHES & PROTECTION PLATES



### 340D

#### Latch Protection Plate

Size: 3" x 11" (76 mm x 279 mm)

Materials: 12 gauge steel, stainless steel

Finishes: US2C, US32D

Fasteners: Two (2) 5/16-20 x 1-1/2" carriage bolts with sex nuts

Notes:

- For use with 1-3/4" (45 mm) doors
- Non-handed
- Frame pin prevents prying of door
- For use with most mortise locks
- For use with cylindrical locksets with a 3-3/4" (95 mm) backset or greater



### 341D

#### Latch Protection Plate with Lock Cut Out

Size: 3" x 11" (76 mm x 279 mm)

Materials: 12 gauge steel, stainless steel

Finishes: US2C, US32D

Fasteners: Two (2) 5/16-20 x 1-1/2" carriage bolts with sex nuts

Notes:

- For use with 1-3/4" (45 mm) doors
- Non-handed
- Frame pin prevents prying of door
- For use with cylindrical locksets with a 2-3/4" (70 mm) backset



### 342D

#### Latch Protection Plate with Escutcheon Cut Out

Size: 3" x 11" (76 mm x 279 mm)

Materials: 12 gauge steel, stainless steel

Finishes: US2C, US32D

Fasteners: Two (2) 5/16-20 x 1-1/2" carriage bolts with sex nuts

Notes:

- For use with 1-3/4" (45 mm) doors
- Non-handed
- For use with cylindrical and mortise locks with a 2-3/4" (70 mm) backset



### 345D

#### Latch Protection Plate

Size: 1-5/8" x 10" (41 mm x 254 mm)

Materials: 12 gauge steel, stainless steel

Finishes: US2C, US32D

Fasteners: Two (2) 5/16-20 x 1-1/2" carriage bolts with sex nuts

Notes:

- For use with 1-3/4" (45 mm) doors
- Non-handed
- For use with cylindrical and mortise locks

## LATCHES & PROTECTION PLATES



### 1442

#### Roller Latch with Full Lip Strike

- Certification: Meets ANSI A156.16 for E09091  
Roller Faceplate: 1" x 3-3/8" (25 mm x 86 mm)  
Strike: 1-11/16" x 2-1/4" (43 mm x 57 mm)  
Strike Gauge: 5/32" (4 mm)  
Materials: Brass  
Finishes: US3, US4, US10, US10B, US15, US15A, US19, US26, US26D  
Fasteners: Two (2) #10 x 1-1/2" FPHWS, two (2) #8 x 1" FPHWS, and two (2) 8-32 x 3/4" FPHMS  
Options: Non-ferrous available with extended lead time  
Notes:
  - Adjustable spring tension with nylon roller
  - Projection of roller is easily adjusted using screws on faceplate
  - Max projection of the roller is 3/8" (9.5 mm) allowing for variance in door and frame clearance



### 1443

#### Roller Latch with ASA Strike

- Certification: Meets ANSI A156.16 for E09101  
Roller Faceplate: 1" x 3-3/8" (25 mm x 86 mm)  
Strike: 1-1/4" x 4-7/8" (32 mm x 124 mm)  
Strike Gauge: 0.090" (2.3 mm)  
Materials: Brass  
Finishes: US3, US4, US10, US10B, US15, US15A, US19, US26, US26D  
Fasteners: Two (2) #10 x 1-1/2" FPHWS, two (2) #12 x 3/4" FPHWS, and two (2) 12-24 x 1/2" FPHMS  
Notes:
  - Adjustable spring tension with nylon roller
  - Projection of roller is easily adjusted using screws on faceplate
  - Max projection of the roller is 3/8" (9.5 mm) allowing for variance in door and frame clearance



## COAT HOOKS



**901P**  
**Coat Hook - Short Single**  
 Diameter: 1" (25 mm)  
 Projection: 1-1/4" (32 mm)  
 Materials: Brass  
 Finishes: US3, US26D  
 Fasteners: #14 x 1-1/4" wood thread  
 Notes: Concealed mounting



**937P**  
**Coat Hook**  
 Projections:
 

- 3-3/4" (95 mm) top hook
- 2-1/2" (63 mm) bottom hook

 Materials: Brass  
 Finishes: US3, US26D



**902P**  
**Coat Hook - Long Single**  
 Diameter: 1" (25 mm)  
 Projection: 2-1/2" (63 mm)  
 Materials: Brass  
 Finishes: US3, US26D  
 Fasteners: #14 x 1-1/4" wood thread  
 Notes: Concealed mounting



**940P**  
**Coat Hook - Double**  
 Overall Height: 4-11/16" (119 mm)  
 Top Projection: 3-15/16" (100 mm)  
 Bottom Projection: 2-1/8" (54 mm)  
 Material Thickness: 1/4" (6 mm)  
 Materials: Brass  
 Finishes: US3, US26D  
 Fasteners: Two (2) #10 x 1" FPHWS



**903P**  
**Coat Hook - Long Double**  
 Diameter: 1" (25 mm)  
 Projection: 2-1/2" (63 mm)  
 Materials: Brass  
 Finishes: US3, US26D  
 Fasteners: #14 x 1-1/4" wood thread  
 Notes: Concealed mounting



**941P**  
**Coat Hook - Single**  
 Overall Height: 2-5/16" (59 mm)  
 Projection: 2-1/8" (54 mm)  
 Material Thickness: 1/4" (6 mm)  
 Materials: Brass  
 Finishes: US3, US26D  
 Fasteners: Two (2) #10 x 1" FPHWS



**936P**  
**Coat Hook Single Angled**  
 Base Diameter: 1-15/16" (49 mm)  
 Hook Diameter: 11/16" (17 mm)  
 Projection: 3-5/16" (84 mm)  
 Materials: Brass  
 Finishes: US3, US26D  
 Notes: Concealed mounting



## COAT HOOKS



**945P**  
**Double Coat Hook - Surface Mounting**  
 Overall Height: 5-1/2" (140 mm)  
 Projection: 3-5/16" (84 mm)  
 Materials: Brass  
 Finishes: US3, US26D  
 Fasteners: Four (4) #10 x 1" FPHWS w/ anchors



**952P**  
**Coat Hook - Single**  
 O/A Height: 2-13/16" (71 mm)  
 Projection: 2-7/32" (56 mm)  
 Materials: Brass  
 Finishes: US3, US26D  
 Notes: Concealed mounting



**946P**  
**Double Coat Hook - Concealed Mounting**  
 Overall Height: 5-1/2" (140 mm)  
 Projection: 3-11/16" (94 mm)  
 Materials: Brass  
 Finishes: US3, US26D  
 Fasteners: Two (2) #10 x 1" FPHWS w/ anchors  
 Notes: Concealed mounting



**956P**  
**Double Coat Hook - Angled**  
 Overall Height: 5-11/16" (144 mm)  
 Projection: 3-23/32" (95 mm)  
 Materials: Brass  
 Finishes: US3, US26D  
 Notes: Concealed mounting



**951P**  
**Coat Hook - Double**  
 O/A Height: 5-3/4" (146 mm)  
 Projection: 2-3/4" (70 mm)  
 Materials: Brass  
 Finishes: US3, US26D  
 Notes: Concealed mounting



**957P**  
**Coat Hook**  
 Projection: 1-3/4" (45 mm)  
 Base Diameter: 3/4" (19 mm)  
 Materials: Brass  
 Finishes: US3, US26D  
 Fasteners: One (1) #10 x 1" wood thread  
 Notes: Concealed mounting



## PULLS - CLOSET/ POCKET/ SLIDING DOOR



### 22N

#### Concealed Edge Pull

Certification: Meets ANSI A156.14 for D2801  
 Size: 31/32" x 4-1/4" x 3/8" thick (25 mm x 108 mm x 9.5 mm)  
 Lever Extension: 2-19/32" (66 mm)  
 Materials: Brass  
 Finishes: US3, US26D  
 Fasteners: Two (2) #6 x 3/4" FPHWS



### 330D

#### Pocket Door Latch

Certification: Meets ANSI A156.14 for D0821  
 Size: 2-3/4" x 2-1/2" (70 mm x 64 mm)  
 Extension of Finger Piece: 1-3/8" (35 mm)  
 Materials: Brass  
 Finishes: US3, US5, US10B, US15A, US19, US26, US26D  
 Fasteners: Two (2) #6 x 5/8" OPHWS  
 Notes: For use with 1-3/8" - 1-3/4" (35 mm - 45 mm) door



### 330L

#### Pocket Door Privacy Latch

Certification: Meets ANSI A156.14 for D0831  
 Size: 2-3/4" x 2-1/2" (70 mm x 64 mm)  
 Extension of Finger Piece: 1-3/8" (35 mm)  
 Strike Size: 1" x 2-1/4" (25 mm x 57 mm)  
 Materials: Brass  
 Finishes: US3, US5, US10B, US15, US15A, US19, US26, US26D  
 Fasteners: Two (2) #6 x 5/8" OPHWS and two (2) #6 x 3/4" FPHWS  
 Notes: For use with 1-3/8" (35 mm) door



### 330M

#### Pocket Door Privacy Latch

Certification: Meets ANSI A156.14 for D0831  
 Size: 2-3/4" x 2-1/2" (70 mm x 64 mm)  
 Extension of Finger Piece: 1-3/8" (35 mm)  
 Strike Size: 1" x 2-1/4" (25 mm x 57 mm)  
 Materials: Brass  
 Finishes: US3, US5, US10B, US15, US15A, US19, US26, US26D  
 Fasteners: Two (2) #6 x 5/8" OPHWS and two (2) #6 x 3/4" FPHWS  
 Notes: For use with 1-3/4" (45 mm) door



### 2610

#### Flush Cup Finger Pull

Overall Diameter: 31/32" (24.5 mm)  
 Finger Pull Diameter: 3/4" (19 mm)  
 Pull Clearance: 5/16" (8 mm)  
 Projection: 1/32" (.8 mm)  
 Materials: Solid brass  
 Finishes: US3, US4, US5, US10A, US15, US15A, US26, US26D, ABA  
 Notes:
 

- For use on bi-fold, by-pass or pocket applications
- Built-in prong design eliminates the need for screws or brads

## PULLS - CLOSET/POCKET/SLIDING DOOR



### 2620

#### Flush Cup Pull

Overall Diameter: 2-1/16" (52 mm)  
 Finger Pull Diameter: 1-11/16" (43 mm)  
 Pull Clearance: 11/32" (8.7 mm)  
 Projection: 5/64" (2 mm)  
 Materials: Solid brass  
 Finishes: US3, US4, US5, US10A, US15, US15A, US26, US26D, ABA  
 Notes:
 

- For use on bi-fold, by-pass or pocket applications
- Built-in prong design eliminates the need for screws or brads



### 2630

#### Flush Cup Pull

Overall Diameter: 2-7/16" (62 mm)  
 Finger Pull Diameter: 2-1/16" (52 mm)  
 Pull Clearance: 11/32" (8.7 mm)  
 Projection: 3/32" (2.4 mm)  
 Materials: Solid brass  
 Finishes: US3, US4, US5, US10A, US15, US15A, US26, US26D, ABA  
 Notes:
 

- For use on bi-fold, by-pass or pocket applications
- Built-in prong design eliminates the need for screws or brads



### 2640

#### Oblong Flush Pull

Size: 1-5/16" x 2-3/4" (33 mm x 70 mm)  
 Cup Clearance: 5/16" (8 mm)  
 Materials: Solid brass  
 Finishes: US3, US4, US5, US10A, US15, US15A, US26, US26D, ABA  
 Fasteners: Two (2) #6 x 5/8" OPHWS  
 Notes: For use on bi-fold, by-pass or pocket applications



### 9558

#### Wood Knob

Diameter: 1-1/2" (38 mm)  
 Materials: Solid wood  
 Notes:
 

- For use on bi-fold applications
- Will accept paint or stain



### 9566

#### Knob

Diameter: 1-1/4" (32 mm)  
 Projection: 1" (25 mm)  
 Materials: Die Cast Zinc  
 Finishes: US3, US4, US5, US10A, US10B, US15, US15A, US26, US26D  
 Fasteners: One (1) 8-32 x 1-3/4" PPHMS and one (1) 8-32 x 2" PPHMS  
 Notes: For use on bi-fold applications on doors 3/4" (19 mm) to 1-3/8" (35 mm) thick





## PULLS - CLOSET/POCKET/SLIDING DOOR



### 9567

#### Rose

- Base Diameter: 1-3/4" (45 mm)  
 Projection: 15/32" (12 mm)  
 Materials: Die cast zinc  
 Finishes: US3, US4, US5, US10A, US10B, US15, US15A, US26, US26D  
 Fasteners: One (1) 8-32 x 1-3/4" PPHMS and one (1) 8-32 x 2" PPHMS  
 Notes:
  - For use on bi-fold applications on doors 3/4" (19 mm) to 1-3/8" (35 mm) thick
  - For use with 9566 knob



### 9865

#### Flush Cup Pull

- Overall Diameter: 1-31/32" (50 mm)  
 Finger Pull Diameter: 1-19/32" (40 mm)  
 Pull Clearance: 11/32" (8.7 mm)  
 Projection: 5/64" (2 mm)  
 Materials: Tan color ABS plastic  
 Notes:
  - For use on bi-fold, by-pass or pocket applications
  - Built-in prong design eliminates the need for screws or brads



### 9882

#### Pocket Door Edge Pull

- Face Plate Size: 3/4" x 3 - 7/8" (19 mm x 98 mm)  
 Finger Pull Extends: 3/4" (19 mm)  
 Materials: Solid brass  
 Finishes: US3, US4, US10, US10B, US26, US26D  
 Fasteners: Two (2) #6 x 5/8" FPHWS  
 Notes:
  - Ideal for narrow and standard door thicknesses
  - Automatic spring return



### 9884

#### Pocket Door Edge Pull

- Faceplate: 21/32" x 3-1/2" (16.5 mm x 89 mm)  
 Finger Pull Extends: 1-1/16" (27 mm)  
 Materials: Die cast zinc  
 Finishes: US3  
 Fasteners: Two (2) #6 x 5/8" FPHWS  
 Notes: Ideal for narrow and standard door thicknesses

## FILLER PLATES



**336A**  
**Door Edge Filler Plate - 161 Prep**  
 Size: 1-1/8" x 2-1/4"  
 (29 mm x 57 mm)  
 Thickness: 0.134" (3.4 mm)  
 Materials: Primed steel



**336G**  
**Door Edge Filler Plate - Square**  
 Size: 1-3/4" x 5"  
 (38 mm x 127 mm)  
 Thickness: 0.134" (3.4 mm)  
 Materials: Primed steel



**336B**  
**Door Edge Filler Plate - 86 Prep**  
 Size: 1-1/4" x 8"  
 (32 mm x 203 mm)  
 Thickness: 0.180" (4.5 mm)  
 Materials: Primed steel



**336H**  
**Door Edge Filler Plate - Beveled**  
 Size: 1-1/2" x 5"  
 (38 mm x 127 mm)  
 Thickness: 0.134" (3.4 mm)  
 Materials: Primed steel  
 Notes: For handed doors



**336C**  
**Door Face Filler Plate**  
 Size: 1-3/4" (45 mm)  
 diameter  
 Thickness: 0.055" (1.4 mm)  
 Materials: Primed steel



**336J**  
**Flush Bolt Strike Filler Plate - Frame**  
 Size: 15/16" x 2-1/4"  
 (24 mm x 57 mm)  
 Thickness: 0.083" (2.1 mm)  
 Materials: Primed steel



**336D**  
**Door Face Filler Plate**  
 Size: 2-5/8" (67 mm)  
 diameter  
 Thickness: 0.055" (1.4 mm)  
 Materials: Primed steel



**336K**  
**Flush Bolt Filler Plate - Door**  
 Size: 1" x 6-3/4"  
 (25 mm x 172 mm)  
 Thickness: 0.134" (3.4 mm)  
 Materials: Primed steel



**336E**  
**Door Edge Filler Plate - Square**  
 Size: 1-3/4" x 4-1/2"  
 (45 mm x 114 mm)  
 Thickness: 0.134" (3.4 mm)  
 Materials: Primed steel



**336L**  
**Hinge Filler Plate - Frame**  
 Size: 1-5/8" x 4-1/2"  
 (41 mm x 114 mm)  
 Thickness: 0.134" (3.4 mm)  
 Materials: Primed steel



**336F**  
**Door Edge Filler Plate - Bevel**  
 Size: 1-1/2" x 4-1/2"  
 (38 mm x 114 mm)  
 Thickness: 0.134" (3.4 mm)  
 Materials: Primed steel  
 Notes: For handed doors





## FILLER PLATES



**336M**  
**Hinge Filler Plate - Frame**  
 Size: 1-5/8" x 5"  
 (41 mm x 127 mm)  
 Thickness: 0.134" (3.4 mm)  
 Materials: Primed steel



**337A**  
**Template Hinge Shim**  
 Size: 1-7/16" x 4-1/2"  
 (37 mm x 114 mm)  
 Thickness: 0.028" (0.7 mm)  
 Materials: Primed steel



**336N**  
**Latch Adapter Filler Plate - 86 to 161 Edge Prep**  
 Size: 1-1/4" x 8"  
 (32 mm x 203 mm)  
 Thickness: 0.238" (6 mm)  
 Materials: Primed steel



**337B**  
**Template Hinge Shim**  
 Size: 1-7/16" x 4-1/2"  
 (37 mm x 114 mm)  
 Thickness: 0.065" (1.7 mm)  
 Materials: Primed steel



**336P**  
**Deadlock Strike Filler Plate - Frame**  
 Size: 1-1/8" x 2-3/4"  
 (29 mm x 70 mm)  
 Thickness: 0.083" (2.1 mm)  
 Materials: Primed steel



**337C**  
**Template Hinge Shim**  
 Size: 1-7/16" x 5"  
 (37 mm x 127 mm)  
 Thickness: 0.028" (0.7 mm)  
 Materials: Primed steel



**336Q**  
**ASA Strike Filler Plate - Frame**  
 Size: 1-1/4" x 4-7/8"  
 (32 mm x 124 mm)  
 Thickness: 0.093" (2.4 mm)  
 Materials: Primed steel



**337D**  
**Template Hinge Shim**  
 Size: 1-7/16" x 5"  
 (37 mm x 127 mm)  
 Thickness: 0.065" (1.7 mm)  
 Materials: Primed steel



**336R**  
**Cylindrical Lock Strike Filler Plate - Frame**  
 Size: 1-1/8" x 2-3/4"  
 (29 mm x 70 mm)  
 Thickness: 0.083" (2.1 mm)  
 Materials: Primed steel

## SIGNAGE

PUSH

### 350H | 350L

#### Engraved Plastic Sign - Push (350H) and Pull (350L)

Certification: Meets ANSI A156.16 L03201  
Materials: 0.125" (3.2 mm) thick plastic  
Lettering: 3/4" (19 mm) Helvetica  
Size: 2" x 4" (51 mm x 102 mm)  
Fasteners: Double-sided pressure sensitive tape or screws (specify)  
Colors:

- Brown (W1) with white lettering
- Black (W2) with white lettering
- Blue (W3) with white lettering
- Silver (B1) with black lettering
- Gold (B2) with black lettering

Notes: Signs are individually packed in a poly bag

PULL

MEN

### 350M | 350W

#### Engraved Plastic Sign - Men (350M) and Women (350W)

Certification: Meets ANSI A156.16 L03201  
Materials: 0.125" (3.2 mm) thick plastic  
Lettering: 3/4" (19 mm) Helvetica  
Size: 2" x 5" (51 mm x 127 mm)  
Fasteners: Double-sided pressure sensitive tape or screws (specify)  
Colors:

- Brown (W1) with white lettering
- Black (W2) with white lettering
- Blue (W3) with white lettering
- Silver (B1) with black lettering
- Gold (B2) with black lettering

Notes: Signs are individually packed in a poly bag

WOMEN

635

### 350R

#### Engraved Plastic Sign - Number

Certification: Meets ANSI A156.16 L03201  
Materials: 0.125" (3.2 mm) thick plastic  
Lettering: 3/4" (19 mm) Helvetica  
Size: 2" x 4" (51 mm x 102 mm)  
Fasteners: Double-sided pressure sensitive tape or screws (specify)  
Colors:

- Brown (W1) with white lettering
- Black (W2) with white lettering
- Blue (W3) with white lettering
- Silver (B1) with black lettering

Notes:

- Signs are individually packed in a poly bag
- Please note numbers to be engraved when ordering

PUSH

PULL

### 351H | 351L

#### Engraved Plastic Sign - Push (351H) and Pull (351L)

Certification: Meets ANSI A156.16 L03201  
Materials: 0.125" (3.2 mm) thick plastic  
Lettering: 3/4" (19 mm) Helvetica  
Size: 1" x 4-1/2" (25 mm x 114 mm)  
Fasteners: Double-sided pressure sensitive tape or screws (specify)  
Colors:

- Brown (W1) with white lettering
- Black (W2) with white lettering
- Blue (W3) with white lettering
- Silver (B1) with black lettering
- Gold (B2) with black lettering

Notes: Signs are individually packed in a poly bag





## SIGNAGE



### 352M | 352W

#### Engraved Plastic Sign - Men (352M) and Women (352W)

Certification: Meets ANSI A156.16 L03201  
 Materials: 0.125" (3.2 mm) thick plastic  
 Lettering: 3/4" (19 mm) Helvetica  
 Size: 352M - 2-1/2" x 6" (64 mm x 152 mm)  
 352W - 2-1/2" x 7" (64 mm x 178 mm)  
 Fasteners: Double-sided pressure sensitive tape or screws (specify)  
 Colors:
 

- Brown (W1) with white lettering
- Black (W2) with white lettering
- Blue (W3) with white lettering
- Silver (B1) with black lettering
- Gold (B2) with black lettering

 Notes: Signs are individually packed in a poly bag

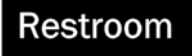

### 354A | 354B

#### Engraved Plastic Sign - Restroom(s)

Certification: Meets ANSI A156.16 L03201  
 Materials: 0.125" (3.2 mm) thick plastic  
 Lettering: 3/4" (19 mm) Helvetica  
 Size: 2" x 6" (51 mm x 127 mm)  
 Fasteners: Double-sided pressure sensitive tape or screws (specify)  
 Colors:
 

- Black (W2) with white lettering
- Blue (W3) with white lettering

 Notes: Signs are individually packed in a poly bag

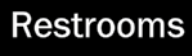

### 360M | 360W

#### Engraved Metal Sign - Men (360M) and Women (360W)

Certification: Meets ANSI A156.16 L03201  
 Materials: 0.050" (1.3 mm) thick metal  
 Lettering: 3/4" (19 mm) Helvetica black filled  
 Size: 2" x 6" (51 mm x 152 mm)  
 Fasteners: Double-sided pressure sensitive tape or screws (specify)  
 Finishes: US3, US28, US32D  
 Notes: Signs are individually packed in a poly bag

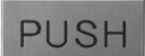

### 361H | 361L

#### Engraved Metal Sign - Push (361H) and Pull (361L)

Certification: Meets ANSI A156.16 L03201  
 Materials: 0.050" (1.3 mm) thick metal  
 Lettering: 3/4" (19 mm) Helvetica black filled  
 Size: 2" x 4" (51 mm x 102 mm)  
 Fasteners: Double-sided pressure sensitive tape or screws (specify)  
 Finishes: US3, US10B, US28, US32D  
 Notes: Signs are individually packed in a poly bag





## SIGNAGE

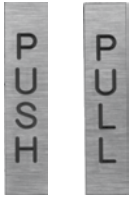

### 362H | 362L Engraved Metal Sign - Push (362H) and Pull (362L)

Certification: Meets ANSI A156.16 L03201  
 Materials: 0.050" (1.3 mm) thick metal  
 Lettering: 3/4" (19 mm) Helvetica black filled  
 Size: 1" x 4-1/2" (25 mm x 114 mm)  
 Fasteners: Double-sided pressure sensitive tape or screws (specify)  
 Finishes: US3, US10B, US28, US32D  
 Notes: Signs are individually packed in a poly bag



### 364M | 364S Plastic International Handicap Symbol

Certification: Meets ANSI A156.16 L03201  
 Materials: 0.0625" (1.6 mm) thick plastic raised HANDICAP symbol  
 Size: 364M - 4" x 4" (102 mm x 102 mm)  
 364S - 3" x 3" (76 mm x 76 mm)  
 Fasteners: Double-sided pressure sensitive tape standard or screws (specify)  
 Colors: Blue (W3) with raised white symbol  
 Notes: Signs are individually packed in a poly bag



### 364N Engraved International No Smoking Symbol

Certification: Meets ANSI A156.16 L03201  
 Materials: 0.125" (3.2 mm) thick plastic  
 Size: 6" x 6" (152 mm x 152 mm)  
 Fasteners: Pressure sensitive tape standard or screws (specify)  
 Colors: Red (W4) with raised white symbol  
 Notes: Signs are individually packed in a poly bag



### 364L Plastic International Handicap Symbol

Certification: Meets ANSI A156.16 L03201  
 Materials: 0.125" (3.2 mm) thick plastic 1/32" (0.8 mm) raised HANDICAP symbol  
 Size: 6" x 6" (152 mm x 152 mm)  
 Fasteners: Double-sided pressure sensitive tape standard or screws (specify)  
 Colors:
 

- Brown (W4) with raised white symbol
- Black (W2) with raised white symbol
- Blue (W3) with raised white symbol

 Notes: Signs are individually packed in a poly bag



### 365M | 365W ADA Tactile Signage - Men (365M) and Women (365W)

Certification: Meets ANSI A156.16 L03201  
 Materials: 0.125" (3.2 mm) thick plastic  
 Size: 6" x 8" (152 mm x 203 mm)  
 Fasteners: Double-sided pressure sensitive tape  
 Colors:
 

- Brown (W1) with raised white symbol
- Black (W2) with raised white symbol
- Blue (W3) with raised white symbol

 Notes:
 

- Signs are individually packed in a poly bag
- Grade 2 Braille Translation conforming to section 4.30 requirements





## SIGNAGE

325

### 366R ADA Tactile Signage - Room Number

- Certification: Meets ANSI A156.16 L03201  
 Materials: 0.125" (3.2 mm) thick plastic  
 Size: 2-1/2" x 5" (64 mm x 127 mm)  
 Fasteners: Double-sided pressure sensitive tape  
 Colors:
  - Brown (W1) with raised white lettering
  - Black (W2) with raised white lettering
  - Blue (W3) with raised white lettering
 Notes:
  - Signs are individually packed in a poly bag
  - Grade 2 Braille Translation conforming to section 4.30 requirements
  - Please note numbers to be engraved when ordering



### 366S ADA Tactile Signage - Stairs

- Certification: Meets ANSI A156.16 L03201  
 Materials: 0.125" (3.2 mm) thick plastic  
 Size: 6" x 8" (152 mm x 203 mm)  
 Fasteners: Double-sided pressure sensitive tape  
 Colors:
  - Brown (W1) with white symbol and lettering
  - Black (W2) with white symbol and lettering
  - Blue (W3) with white symbol and lettering
 Notes:
  - Signs are individually packed in a poly bag
  - Grade 2 Braille Translation conforming to section 4.30 requirements



### 368E ADA Tactile Signage - Exit

- Certification: Meets ANSI A156.16 L03201  
 Materials: 0.125" (3.2 mm) thick plastic  
 Size: 6" x 8" (152 mm x 203 mm)  
 Fasteners: Double-sided pressure sensitive tape  
 Colors:
  - Brown (W1) with white symbol and lettering
  - Black (W2) with white symbol and lettering
  - Blue (W3) with white symbol and lettering
 Notes:
  - Signs are individually packed in a poly bag
  - Grade 2 Braille Translation conforming to section 4.30 requirements



### 368M | 368W ADA Tactile Signage - Men (365M) and Women (365W) with Handicap

- Certification: Meets ANSI A156.16 L03201  
 Materials: 0.125" (3.2 mm) thick plastic  
 Size: 6" x 8" (152 mm x 203 mm)  
 Fasteners: Double-sided pressure sensitive tape  
 Colors:
  - Brown (W1) with white symbol and lettering
  - Black (W2) with white symbol and lettering
  - Blue (W3) with white symbol and lettering
 Notes:
  - Signs are individually packed in a poly bag
  - Grade 2 Braille Translation conforming to section 4.30 requirements





**SIGNAGE**



**368U**

**ADA Tactile Signage - Unisex**

- Certification: Meets ANSI A156.16 L03201
- Materials: 0.125" (3.2 mm) thick plastic
- Size: 8" x 8" (203 mm x 203 mm)
- Fasteners: Double-sided pressure sensitive tape
- Colors:
  - Brown (W1) with white symbol and lettering
  - Black (W2) with white symbol and lettering
  - Blue (W3) with white symbol and lettering
- Notes:
  - Signs are individually packed in a poly bag
  - Grade 2 Braille Translation conforming to section 4.30 requirements



**369L | 369R**

**ADA Tactile Signage - Access Left (369L) and Access Right (369R)**

- Certification: Meets ANSI A156.16 L03201
- Materials: 0.125" (3.2 mm) thick plastic
- Size: 6" x 8" (152 mm x 203 mm)
- Fasteners: Double-sided pressure sensitive tape
- Colors:
  - Brown (W1) with white symbol and lettering
  - Black (W2) with white symbol and lettering
  - Blue (W3) with white symbol and lettering
- Notes:
  - Signs are individually packed in a poly bag
  - Grade 2 Braille Translation conforming to section 4.30 requirements



**370U | 370W | 370M**

**ADA Tactile Signage - Restroom, Men, and Women**

- Certification: Meets ANSI A156.16 L03201
- Materials: 9/16" (14.3 mm) plastic
- Size:
  - 370U - 12" (305 mm) diameter
  - 370W - 12" (305 mm) diameter
  - 370M - 10-1/2" (267 mm) side
- Fasteners: Double-sided pressure sensitive tape
- Color: Blue (W3) with white raised symbol and lettering
- Notes:
  - Signs are individually packed in a poly bag
  - Grade 2 Braille Translation conforming to section 4.30 requirements





## MISCELLANEOUS



### 274B

#### Door Guard Protection Plate

- Size: 1-1/8" x 1" x 1/2" (28.5 mm x 25 mm x 12.5 mm)  
 Materials: Brass  
 Finishes: US3, US4, US10, US10B, US15, US26, US26D  
 Notes:
  - Used when additional protective plate is required for frame application
  - Mounted with double-sided tape
  - To be used with the 274D



### 274C

#### Shim for Door Guard

- Size:
  - 1-1/16" X 1-5/8" (27 mm X 41 mm)
  - 1-1/8" x 1-1/16" (29 mm x 27 mm)
 Thickness: 3/32" (2.3 mm)  
 Materials: Black rubber  
 Notes: To be used with the 274D



### 274D

#### Door Guard

- Certification: Meets ANSI A156.16 for L13041  
 Arm Length: 4-1/2" (114 mm)  
 Materials: Brass  
 Finishes: US3, US4, US10, US10B, US15, US26, US26D  
 Fasteners: Three (3) #6 x 1-1/2" OPHWS, four (4) #6 x 3/4" OPHWS, and seven (7) 6-32 x 12" OPHMS  
 Notes:
  - Permits door to be slightly opened to allow viewing
  - Hinged bar allows the door guard to be positioned 180 degrees away from the door when not in use
  - Includes door guard protective plate 274B



### 277D

#### Door Guard

- Certification:
  - Meets NFPA 80 5.2.13.3
  - Meets NFPA 80 5.2.4.2(9)
  - ADA Compliant Arm
 Size:
  - Base: 2-5/8" H x 1-9/16" W
  - Projection: 2-3/16"
 Materials: Cast zinc  
 Finishes: US3, US4, US10B, US15, US26, US26D  
 Fasteners:
  - Three (3) #12 x 1- 3/4" FPHSMS
  - Three (3) 12-24 machine screws



### 300D

#### Chain Door Check

- Certification: Meets ANSI A156.16 for L02231  
 Lengths:
  - 25-1/2" (648 mm) recommended for use with 36" (914 mm) wide door
  - 30-1/2" (775 mm) recommended for use with 42" (1067 mm) wide door
 Base Plate: 1-1/2" x 1-1/2" (38 mm x 38 mm)  
 Materials:
  - Cast zinc base
  - Galvanized steel chain
  - EDPM rubber cover
 Finish: US26D  
 Fasteners: Ten (10) #8 x 1" FPHSMS  
 Notes:
  - Tear resistant grey vinyl cover
  - Can be ordered through door mounting with grommet nut sets at extra charge
  - 440 pound load strength
  - Designed for full size exterior doors

## MISCELLANEOUS



### 301D Residential Stop

- Certification: Meets ANSI A156.16 for L02223  
 Materials: Wrought steel with rubber bumpers  
 Finishes: 2C, US3  
 Notes:
  - Works with 1/4" (6 mm) and 5/16" (8 mm) hinge pins
  - For use where standard door stops are not desirable
  - Positive slip proof design
  - Adjustable from 70 degrees to 100 degrees
  - Must purchase an NRP hinge for use with this pinstop



### 303W Handrail Bracket

- Certification: Meets ANSI A156.16 for L03061  
 Base Diameter: 3-5/32" (80 mm)  
 Base to Center of Rail: 2-3/4" (70 mm)  
 Materials: Brass  
 Finishes: US3, US4, US10, US10B, US15A, US19, US26, US26D  
 Fasteners: Three (3) #10 x 1-1/4" FPHWS, three (3) plastic anchors, three (3) 10-24 x 13/16" FPHMS, and three (3) 10-24 lead anchors



### 305D Wire Pull

- Certification: Meets ANSI A156.9 for B02011  
 Diameter of Rod: 5/16" (7.9 mm)  
 Projection: 1-9/32" (32.5 mm)  
 CTC Lengths: 3" (76 mm), 3-1/2" (89 mm), 4" (102 mm)  
 Materials: Brass  
 Finishes: US3, US4, US10, US10B, US26, US26D  
 Fasteners: Two (2) 8-32 x 1" TPHMS



### 307D Door Silencer

- Certification: Meets ANSI A156.16 for L03011  
 Diameter: 1/2" (13 mm)  
 Projection: 1/8" (3 mm)  
 Materials: Rubber  
 Notes:
  - For use with metal frames
  - Proper installation eliminates door rattle and provides constant tension for door latches or locks



### 308D Door Silencer

- Certification: Meets ANSI A156.16 for L0302  
 Projection: 9/64" (3.5 mm)  
 Base: 3/8" x 3/4" (9.5 mm x 19 mm)  
 Length: 3/4" (19 mm)  
 Materials: Rubber  
 Notes:
  - For use with wood frames
  - Eliminates door rattle when door is latched
  - Proper installation eliminates door rattle and provides constant tension for door latches or locks





## MISCELLANEOUS



### 310C Conversion Kit

- Filler Plate: 1-1-8" x 3-3/8" (29 mm x 86 mm)  
 Strike: 1-11/16" x 2-1/4" (43 mm x 57 mm)  
 Materials: Brass  
 Finishes: US10B, US26D  
 Notes:
  - Packed with filler plate, strike and fasteners
  - Change door from Roller Latch to Push/Pull Latch



### 322V Wrought Door Knocker with Viewer (115°)

- Certification: Meets ANSI A156.16 for L03163  
 Size: 2-3/16" x 3-1/4" (56 mm x 83 mm)  
 Materials: Brass  
 Finishes: US3, US4, US10, US26D  
 Fasteners: Three (3) #6 x 3/4" TPHSMS  
 Engraving: Available up to four characters  
 Notes: Requires 1/2" (13 mm) hole for viewer



### 334V Door Knocker with Viewer (115°)

- Certification: Meets ANSI A156.16 for L03163  
 Size: 3-9/16" x 6-3/4" (90.5 mm x 171.5 mm)  
 Materials: Solid Cast Brass  
 Finishes: US3, US4, US10, US10B, US26, US26D  
 Fasteners:
  - Two (2) #8 finish washers
  - Two (2) 7-32 x 1-7/8" OHMS for 1-5/8" doors
  - Two (2) 7-32 x 2" OHMS for 1-3/4" doors
 Engraving: Available up to four characters



### 1755 115° Door Viewer

- Certification: Meets ANSI A156.16 for L03223  
 Materials: Brass  
 Finishes: US3, US4, US5, US10A, US15, US15A, US26, US26D  
 Door Thickness: 1-3/8" - 2-1/8" thick, adjustable  
 Notes:
  - For doors up to 2-1/8" (54 mm) thick, adjustable
  - Requires 1/2" (13 mm) hole for viewer
  - Tamper resistant
  - 90 minute fire-rated
  - One-way viewer



## MISCELLANEOUS



### 1756

#### 185° Door Viewer

- Certification: Meets ANSI A156.16 for L03223  
 Materials: Brass  
 Finishes: US3, US4, US5, US10A, US15, US15A, US26, US26D  
 Notes:
  - For doors up to 2-1/8" (54 mm) thick, adjustable
  - Requires 9/16" (14 mm) hole for viewer
  - Tamper resistant
  - 90 minute fire-rated
  - One-way viewer



### 1758

#### 115° Door Viewer with Privacy Flap

- Certification: Meets ANSI A156.16 for L03223  
 Materials: Brass  
 Finishes: US3, US10A, US26, US26D  
 Notes:
  - Requires 1/2" (13 mm) hole for viewer
  - For doors 1-3/8" (35 mm) to 2-1/8" (54 mm) thick, adjustable
  - Tamper resistant
  - 90 minute fire-rated
  - One-way viewer
  - Flap diameter - 3/4"



### 1759

#### 185° Door Viewer with Privacy Flap

- Certification: Meets ANSI A156.16 for L03223  
 Materials: Brass  
 Finishes: US3, US10A, US26, US26D  
 Notes:
  - Requires 9/16" (14 mm) hole for viewer
  - For doors 1-3/8" (35 mm) to 2-1/8" (54 mm) thick, adjustable
  - Tamper resistant
  - 90 minute fire-rated
  - One-way viewer
  - Flap diameter - 3/4"



### 1765

#### Privacy Flap for Use with Hager 115° Door Viewer (1755)

- Materials: Brass  
 Finishes: US3, US10A, US26, US26D  
 Notes: Flap diameter - 3/4"



### 1766

#### Privacy Flap for Use with Hager 185° Door Viewer (1756)

- Materials: Brass  
 Finishes: US3, US10A, US26, US26D  
 Notes: Flap diameter - 3/4"





## RESIDENTIAL



### 208

#### Kick Down Door Stop

- Base: 1-5/8" x 1-7/8" (41 mm x 48 mm)  
 Arm: 3-7/8" (98 mm)  
 Materials: Aluminum alloy  
 Finishes: US3, US4, US5, US10A, US15A, US15, US26, US26D, ABA  
 Fasteners: Three (3) #6 x 3/4" FPHWS  
 Notes:
  - Poly bag (1 each) with screws
  - Provides simple hold and release with a touch of the foot
  - 3" (76 mm) max door to floor clearance



### 209

#### Floor Door Stop

- Height: 1-1/4" (32 mm)  
 Base Diameter: 1-3/32" (28 mm)  
 Tip Diameter: 19/32" (15 mm)  
 Materials: Zinc alloy  
 Finishes: US3, US4, US5, US10A, US15A, US15, US26, US26D, ABA  
 Fasteners: One (1) #8 x 2" FPHWS  
 Notes:
  - Non-marking white tip
  - 3/8" (9.5 mm) max door to floor clearance



### BL6209

#### Floor Door Stop

- Height: 1-3/8" (35 mm)  
 Base Diameter: 13/16" (21 mm)  
 Tip Diameter: 1/2" (13 mm)  
 Materials: Zinc alloy  
 Finishes: US3, US4, US5, US10A, US15A, US15, US26, US26D, ABA  
 Fasteners: #8 x 1 1/32" thread  
 Notes:
  - Non-marking white tip
  - 150 per case
  - 1/2" (13 mm) max door to floor clearance
  - Hex shape near the base allows usage of a wrench for easier installation



### 210

#### Rigid Door Stop

- Projection: 3" (76 mm)  
 Tip Diameter: 11/16" (17.5 mm)  
 Base Diameter: 1" (25 mm)  
 Materials: Zinc alloy  
 Finishes: US3, US4, US5, US10A, US10R, US15A, US15, US26, US26D, ABA  
 Fasteners: #8 x 5/8" thread  
 Notes: Bumper made of rubber



## RESIDENTIAL



### 211

#### Flexible Door Stop

Projection: 3-1/8" (79 mm)  
 Tip Diameter: 9/16" (14 mm)  
 Base Diameter: 1" (25 mm)  
 Materials: Steel  
 Finishes: US3, US4, US5, US10A, US10R, US15A, US15, US26, US26D, ABA  
 Fasteners: One (1) #8 x 3/4" PPHWS  
 Notes:
 

- Bumper made of rubber
- Flexible spring



### BL6211

#### Flexible Door Stop

Projection: 3" (76 mm)  
 Tip Diameter: 7/16" (11 mm)  
 Base Diameter: 3/4" (19 mm)  
 Materials: Zinc alloy base  
 Finishes: US3, US4, US5, US10A, US10R, US15A, US15, US26, US26D, ABA  
 Fastener: #8 x 11/32" thread  
 Notes:
 

- Bumper made of rubber
- Flexible spring



### 212

#### Hinge Pin Door Bumper

Materials: Zinc alloy base  
 Finishes: US3, US4, US5, US10A, US10R, US15A, US15, US26, US26D, ABA  
 Notes:
 

- Non-marking white plastic tip
- For use where standard door stops are not desirable
- For use with narrow trim
- Adjustable from 80 degrees to 120 degrees
- For use with residential hinges
- Works with 1/4" (6 mm) hinge pins



### BL6212

#### Hinge Pin Door Bumper

Materials: Zinc alloy base  
 Finishes: US3, US4, US5, US10A, US10R, US15A, US15, US26, US26D, ABA  
 Notes:
 

- Non-marking white plastic tip
- Works with 1/4" (6 mm) hinge pins
- For use where standard door stops are not desirable
- For use with narrow trim
- Adjustable from 80 degrees to 120 degrees
- For use with residential hinges



### 1412

#### Door Guard

Arm Length: 4 (102 mm)  
 Materials: Zinc alloy base  
 Finishes: U3, US4, US5, US10A, US15A, US15, US26, US26D, ABA  
 Fasteners: Seven (7) #6 x 3/4" FPHWS  
 Notes:
 

- Provides extra security from inside door
- Limits door opening when latch is thrown
- Poly bag (1 each) with screws





## RESIDENTIAL



### 1413

#### Flush Bolt

Faceplate: 3/4" x 6" (19 mm x 181 mm)  
 Strike: 7/8" x 1-3/4" (22 mm x 45 mm)  
 Bolt Diameter: 1/2" (13 mm)  
 Bolt Throw: 15/16" (24 mm)  
 Bolt Backset: 7/16" (11 mm)  
 Materials: Brass faceplate with steel components  
 Finishes: US3, US4, US5, 10A, 10R, US15A, US15, US26, US26D, ABA, AN  
 Fasteners: Four (4) #6 x 3/4" FPHWS  
 Notes:
 

- Poly bag (1 each) with strikeplate and screws
- Square corners



### 1414

#### Flush Bolt

Faceplate: 3/4" x 6" (19 mm x 181 mm)  
 Strike: 7/8" x 1-3/4" (22 mm x 45 mm)  
 Bolt Diameter: 1/2" (12.7 mm)  
 Bolt Throw: 15/16" (24 mm)  
 Bolt Backset: 7/16" (11 mm)  
 Materials: Brass faceplate with steel components  
 Finishes: US3, US4, US5, 10A, 10R, US15A, US15, US26, US26D, ABA, AN  
 Fasteners: Four (4) #6 x 3/4" FPHWS  
 Notes:
 

- Poly bag (1 each) with strikeplate and screws
- Rounded corners



### 1415

#### Strike Plate

Size: 7/8" x 1-3/4" (22 mm x 45 mm)  
 Finishes: US3, US10A, US15A, US15, US26D  
 Fasteners: Two (2) #6 x 3/4" FPHWS  
 Notes:
 

- For use with 1413 and 1414 Flush Bolts
- Packed (1 each) with Poly bag and screws



### 1416

#### Single Route Flush Bolt

Faceplate: 3/4" x 7-1/8" (19 mm x 181 mm)  
 Strike: 21/32" x 1-1/2" (17 mm x 38 mm)  
 Bolt Diameter: 5/16" (8 mm)  
 Bolt Throw: 7/8" (22 mm)  
 Bolt Backset: 3/8" (9.5 mm)  
 Materials: Brass faceplate with steel components  
 Finishes: US3, US4, US5, US10A, US10R, US15A, US15, US26, US26D, ABA  
 Fasteners: Two (2) #8 x 1-1/2" FPHWS and two (2) #6 x 3/4" FPHWS  
 Notes:
 

- Poly bag (1 each) with strikeplate and screws
- Rounded corners
- Single route for quick and simple door prep

## RESIDENTIAL



### 1418

#### Flush Bolt with Extension Rod

- Faceplate: 23/32" x 7-3/8" (18 mm x 187 mm)  
 Strike: 5/8" x 1-1/2" (16 mm x 38 mm)  
 Bolt Diameter: 5/16" (8 mm)  
 Bolt Throw: 3/4" (19 mm)  
 Bolt Backset: 3/8" (9.5 mm)  
 Extension Rod Length: 16" (406 mm)  
 Materials: Brass faceplate with steel components  
 Finishes: US3, US4, US5, US10A, US10R, US15A, US15, US26, US26D, ABA  
 Fasteners: Two (2) #8 x 1-1/2" FPHWS and two (2) #6 x 3/4" FPHWS  
 Notes:
  - Poly bag (1 each) with strikeplate and screws
  - Rounded corners
  - Single route for quick and simple door prep



### 1419

#### Flush Bolt with Extension Rod

- Faceplate: 3/4" x 7-1/8" (19 mm x 181 mm)  
 Strike: 5/8" x 1-1/2" (16 mm x 38 mm)  
 Bolt Diameter: 5/16" (8 mm)  
 Bolt throw: 3/4" (19 mm)  
 Bolt Backset: 5/16" (8 mm)  
 Materials: Brass faceplate with steel components  
 Fasteners: Two (2) #8 x 1-1/2" FPHWS and two (2) #6 x 3/4" FPHWS  
 Finishes: US3, US4, US10A, US10R, US15, US26, US26D, ABA, AN  
 Notes: Single route for quick and simple door prep



### 1439 | BL6439

#### Magnetic Catch - Light Weight

- Catch: 1-1/16" x 2" (27 mm x 51 mm)  
 Strike: 7/8" x 1" (22 mm x 25 mm)  
 Materials: Tan plastic case  
 Fasteners: Two (2) #6 x 1/2" TPHWS and one (1) #4 x 1/2" FPHWS  
 Notes:
  - Poly bag (1 each) with screws
  - Double-sided magnet, self-aligning, 6 lb. pull
  - Self aligning magnet insures maximum pull
  - BL6439 is Builder's Pack Poly bag (1 each) with screws



### 1445

#### Roller Latch

- Hole Diameter: 13/16" (21 mm)  
 Hole Depth: 1-1/8" (29 mm)  
 Materials: Zinc alloy base  
 Finishes: US3, US4, US5, US10A, US10R, US15A, US15, US26, US26D, ABA  
 Fasteners: Two (2) #4 x 3/4" FPHWS  
 Notes:
  - Poly bag (1 each) with screws
  - Designed for use on cabinets and lightweight doors
  - Not intended for heavy weight applications



## RESIDENTIAL



### 1446

#### Light Weight Ball Catch

- Faceplate: 1" x 2-1/4" (25 mm x 57 mm)  
 Strike: 1-3/8" x 2-1/4" (35 mm x 57 mm)  
 Hole Diameter: 1" (25 mm)  
 Hole Depth: 1-1/4" (32 mm)  
 Materials: Steel housing, brass strike, plated steel ball  
 Finishes: US3, US4, US5, US10A, US10R, US15A, US15, US26, US26D  
 Fasteners: Four (4) #6 FPHWS  
 Notes:
  - Designed for use on cabinets and light weight doors
  - Not intended for heavy weight applications
  - Ball adjusts in and out for various door and frame clearances
  - Poly bag (1 each) with steel screws



### 1447

#### Light Weight Ball Catch

- Strike: 1-3/8" x 2-1/4" (35 mm x 57 mm)  
 Faceplate: 1" (25 mm) diameter  
 Hole Diameter: 15/16" (24 mm)  
 Hole Depth: 1-1/4" (32 mm)  
 Materials: Zinc housing, brass strike, plated steel ball  
 Finishes: US3, US4, US5, US10A, US10R, US15A, US15, US26, US26D  
 Fasteners: Two (2) #6 FPHWS  
 Notes:
  - Designed for use on cabinets and light weight doors
  - Not intended for heavy weight applications
  - Ball adjusts in and out for various door and frame clearances
  - Poly bag (1 each) with steel screws



### 1448

#### Strike Plate

- Size: 1-3/8" x 2-1/4" (35 mm x 57 mm)  
 Material: Brass  
 Finishes: US3, US4, US5, US10A, US10R, US15A, US15, US26, US26D, ABA  
 Fasteners: Two (2) #6 FPHWS  
 Notes: For use with 1446 and 1447 ball catches



### 1449

#### Drive In Ball Catch

- Faceplate: 1" (25 mm) diameter  
 Hole Diameter: 15/16" (24 mm)  
 Hole Depth: 1-1/4" (32 mm)  
 Materials: Zinc housing, plated steel ball  
 Finishes: US4  
 Packaging: 100 per box  
 Notes:
  - Ball catch designed for use on cabinets and light weight doors
  - Not intended for heavyweight applications
  - Ball adjusts in and out for various door and frame clearances

## RESIDENTIAL



### 1792 Center Support

- Overall Height: 2-9/16" (65 mm)  
 Projection: 2-11/16" (68 mm)  
 Fasteners: Two (2) #8 x 3/4" TPHWS  
 Notes:
  - For closet rod
  - Bracket testing conforms to ANSI A156.15
  - Poly bag (1 each) without screws



### BL6793 Pole Sockets

- Outside Diameter: 2-7/16" (62 mm)  
 Materials: Steel  
 Notes:
  - For poles up to 1-3/8" (35 mm) diameter
  - Flange design prevents accidental knock out of pole
  - Poly bag (2 each) with screws



### BL6794 Pole Sockets

- Outside Diameter: 2-3/16" (56 mm)  
 Materials: Plastic  
 Notes:
  - For poles up to 1-3/8" (35 mm) diameter
  - Poly bag (2 each) with screws



### 1795 Closet Rod

- Pole Diameter: 1" (25 mm)  
 Available Lengths: 18" - 30"  
 30" - 48"  
 48" - 72"  
 72" - 96"  
 96" - 150"  
 Materials: Steel with bright zinc finish  
 Finishes: White enamel  
 Fasteners: Six (6) #8 x 1" TPH tapping screws  
 Notes:
  - Quick mount end
  - High strength lock seam tubing
  - Poly bag (1 each) with screws



### 1797 Shelf Bracket with 2-1/2" Drop

- Materials: Steel ANSI B04051  
 Finishes: White Enamel  
 Fasteners: Two (2) #8 x 5/8" PPH tapping screws and two (2) #10 x 1-1/2" PPH tapping screws  
 Notes:
  - For shelf and rod support
  - Heavy gauge steel construction embossed for added strength
  - Holds 1-3/8" (35 mm) diameter rod
  - Supports 12" (305 mm) shelf
  - Bulk with screws
  - 150 lbs. load rating





## RESIDENTIAL



### 1798

#### Shelf Bracket with 3" Drop

Materials: Steel ANSI B04051  
 Finishes: White Enamel  
 Fasteners: Two (2) #8 x 5/8" PPH tapping screws and two (2) #10 x 1-1/2" PPH tapping screws

- Notes:
- For shelf and rod support
  - Heavy gauge steel construction embossed for added strength
  - Holds 1-3/8" (35 mm) diameter rod
  - Supports 12" (305 mm) shelf
  - Bulk with screws
  - 150 lbs. load rating



### 1799

#### Shelf Bracket - Adjustable

Materials: Steel ANSI B04051  
 Finishes: White Enamel  
 Fasteners: Two (2) #8 x 3/4" PPH tapping screws and two (2) #10 x 1-1/2" PPH tapping screws

- Notes:
- Adjustable shelf and rod support
  - Heavy gauge steel construction embossed for added strength
  - Holds 1-3/8" (35 mm) diameter rod
  - Supports 12" (305 mm) shelf
  - 3/4" (19 mm) adjustability
  - Bulk with screws



### 1801

#### Shelf Bracket

Materials: Steel ANSI B04051  
 Finishes: White enamel  
 Fasteners: Two (2) #8 x 5/8" PPH tapping screws and two (2) #10 x 1-1/2" PPH tapping screws

- Notes:
- Less rod support
  - Heavy gauge steel construction embossed for added strength
  - Supports 12" (305 mm) shelf
  - Bulk with screws



### 6601

#### Handrail Bracket

Projection: 3-1/4" (82.5 mm)  
 Base to Center of Rail: 2-3/4" (70 mm)  
 Materials: Cast aluminum  
 Finishes: US3, US4, US5, US10A, US10R, US15, US15A, US26, US26D, ABA  
 Fasteners: Three (3) #8 x 1-1/2" OPHWS and two (2) #8 x 3/4" OPHWS  
 Notes: Poly bag (1 each) with wood screws and rail bracket



### BL6610

#### Coat and Hat Hook

Upper Projection: 2-13/16" (71 mm)  
 Lower Projection: 1-5/16" (33 mm)  
 Material: Cast steel  
 Finishes: US3, US4, US5, US10A, US15A, US15, US26, US26D, ABA  
 Fasteners: Two (2) #6 x 3/4" FPHWS  
 Notes:
 

- Poly bag (1 each) with screws
- Builder's pack



**One Family. One Brand. One Vision.™**

[www.hagerco.com](http://www.hagerco.com)

# Thresholds & Weatherstripping

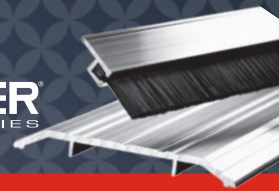

Hager Companies offers a complete line of thresholds & weatherstripping products for virtually any type of door application. What's more, each meets or exceeds ANSI-grade quality, durability, and performance levels. For enhanced levels of safety and security, we also offer intumescent products for positive pressure solutions, including edge sealing and smoke control systems. All of which make Hager threshold, weatherstripping, and door bottom products an excellent choice for standard or custom applications in schools, hospitals, office buildings, and more.

## Table of Contents

General Information .....	2
---------------------------	---

### Thresholds

Saddle .....	6
Thermal Barrier Saddle .....	8
Half Saddle .....	9
Elevator and Bumper Strips .....	10
Residential and Carpet.....	11
Bumpers and ADA Ramps.....	12
Floor Plate Assembly .....	13
Panic .....	14
Thermal Barrier Panic .....	15
Interlocking .....	16
Abrasive Cast Aluminum .....	17
Floor Closer .....	18
Cover Plate and Anchors .....	19

### Weatherstripping

Interlocking/Overhead Drip Guards .....	20
Press-On Gasketing .....	21
Door Bottoms .....	23
Automatic Door Bottoms .....	25
Door Bottom Sweeps.....	26
Jamb Weatherstripping.....	29
Astragals/Meeting Stiles .....	35





## GENERAL INFORMATION

### PRODUCT PRESENTATION

Dimensions on bronze and stainless steel extrusions may differ slightly than those detailed. Questions regarding any dimensions should be directed to Hager Companies Customer Service.

Drawings or illustrations used in the catalog are subject to change without notice. Questions on any dimensions should be obtained by contacting Hager Companies Customer Service.

### FABRICATION OPTIONS

- Bevel one edge of threshold
- Rip one edge width of threshold
- L-notch both ends of threshold
- U-notch both ends of threshold
- Miter single one end of threshold
- Miter single both ends of threshold
- Miter double one end of threshold
- Miter double both ends of threshold
- Tack weld one line of threshold
- Pan for water return of threshold
- Sure Step Non-Slip Abrasive Coating – A rugged, durable coating that can be applied to all Hager Companies' metal thresholds. Ideal for thresholds being used in wet, oily or corrosive environments.

### MATERIALS & FINISHES

#### Metals

All aluminum extrusions are of alloy 6063-T5. All bronze extrusions are of alloy CDA385 brass specified as Architectural Bronze in the industry.

For stock finishes, refer to the code listed below each individual item throughout the catalog. Please inquire for the availability on nonstock finishes.

- MIL** - mill finish aluminum
- CAL** - cast aluminum
- GYP** - primed steel grey
- DBA** - dark bronze anodized aluminum
- SCA** - Hager Sure Step on aluminum
- 32D** - stainless steel (non-extruded)
- GLD** - gold anodized aluminum
- CLR** - clear anodized aluminum
- LBA** - light bronze anodized aluminum
- SCB** - Hager Sure Step on bronze
- WHP** - white paint on aluminum
- USP** - prime coat

Notes: Threshold profiles shown refer to aluminum material only, dimensions may vary for mill finish bronze thresholds.

#### Gaskets

Gasketing is available in a wide variety of materials. Vinyl is an economical choice and remains flexible down to -40°F (-40°C). EPDM gasketing is supplied both as a solid (dense) and as a closed cell sponge with a tough outer skin. It remains flexible down to -50°F (-49°C). Silicone gasketing provides the best resistance to cold by remaining flexible down to -70°F (-57°C). Refer to the price book for a list of available replacement gaskets. Gasketing codes are listed below.

- B** - nylon brush
- F** - vinyl with fins
- N** - neoprene
- S** - silicone
- V** - vinyl
- W** - pile (thread may be removed to allow expansion)

### ORDERING INFORMATION

When ordering, please specify by product number, length, quantity, finish and fasteners required. Thresholds & weatherstripping are fabricated in standard sizes with 1/2" (12.7 mm) extra on thresholds 50" (1270 mm) and under. Thresholds over 50" (1270 mm) are supplied with 1" (25 mm) extra length for fitting. Exact lengths are available upon request (specify CTEL).

Example: **891S V 36 x 84 MIL**

Item #	Gasketing	Size	Finish
515S	W-pile	36" (914 mm)	MIL - mill finish aluminum
599S	V-vinyl	48" (1219 mm)	DBA - dark bronze anodized aluminum
750S	S-silicone	36" (914 mm)	32D - matte stainless steel
870S	N-neoprene	36" x 84" (914 mm x 2133 mm)	CLR - clear anodized aluminum
882S	B-nylon Brush	48" x 96" (1219 mm x 2438 mm)	OOO - gasket only
881S	N-neoprene	48" x 84" (914 mm x 2133 mm)	



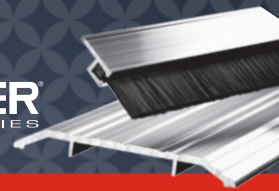

## GENERAL INFORMATION

### FASTENERS

#### Standard

All products are furnished with appropriate fasteners as listed, except where noted. Most thresholds are furnished with mounting holes and #10 x 1-1/2" flat head sheet metal screws. Most weatherstripping products are furnished with slotted holes and #6 x 5/8" pan head sheet metal screws.

#### Optional

##### Thresholds

- #10 wood screws and plastic anchors
- #10 wood screws and lead anchors
- #10 machine screws and lead anchors
- #10 stainless steel wood screws
- #10 stainless steel wood screws and plastic anchors
- #10 stainless steel wood and lead anchors
- 1/4-20 stainless steel machine screws and lead anchors
- 1/4-20 machine screws and lead anchors
- 1/4-20 x 2" flat head sleeve anchor
- #10 torx sheet metal screws
- #10 stainless steel torx wood screws
- #10-24 x 1-1/2" stainless steel torx machine screw with lead anchor
- #10-stainless steel spanner head wood screw with lead anchor
- Cast-on anchors (cast products only)
- Tap-con type (1/4" x 1-3/4")

##### Weatherstripping

- #6 x 5/8" pan-head stainless steel screws
- #6 x 5/8" self-drilling (TEK) screws (Steel-zinc plated)
- #6 x 5/8" pan-head torx sheet metal screws
- #6 x 5/8" stainless steel self-drilling (TEK) screws
- 1/4 - 20 x 1-1/4" sex bolts
- Two-way self-adhesive tape

### GENERAL INSTALLATION INSTRUCTIONS FOR PRESS-ON PRODUCTS:

- Product returnable within first 6 months after purchase date
- Installation should take place after construction has been completed, and final cleaning has taken place
- The frame should be cleaned; isopropyl alcohol is recommended
- Not recommended for unsealed or porous applications
- Do not store these products in extreme heat/cold or for prolonged periods of time

### CERTIFICATIONS



#### Handicap Accessibility

Products denoted by this symbol are designed for applications where handicap accessibility is specified. These products are no greater than 1/2" (12.7 mm) in height and have no more than 1/4" (6.3 mm) vertical rise or with slope proportions no greater than 1:2 slope. Offset floor conditions greater than 1/2" (12.7 mm) require a 1:12 slope.



#### Air Infiltration

Products denoted by this symbol have been tested with air/smoke infiltration, all within the (0.500 cfm/sq. ft. for double doors and .300 cfm for single doors) maximum allowable leakage at a pressure of a 25 mph wind (1.56 psf). The tests were conducted in accordance with ASTM test procedures and meet ASTM: E283-91.



#### Sound Tested

Products denoted by this symbol have been sound tested and received the appropriate STC rating. The tests were conducted in accordance with ASTM test procedures and meet ASTM: E90-90 & ASTM: E413-87.

STC Rating Static Door	STC Rating Operable Door	Perimeter Seal	Automatic Door Bottom	Threshold
44	40	726	743S	520S
41	39	726 (2)	743S	520S



#### BHMA Certified

BHMA Certification Program was developed as a means for manufacturers of builders hardware to indicate compliance with American National Standards sponsored by BHMA. Participating manufacturers certify compliance with the standards based on a continuing program of passing the prescribed tests.



#### Underwriter's Laboratories

Products denoted by this symbol are classified and labeled by Underwriter's Laboratories, Inc.® as gasket material for use on listed steel frames and/or classified swinging type fire doors of the hollow metal or steel covered composite type rated up to 3 hours, or wood core fire doors rated up to 1-1/2 hours. Test results show these products do not adversely affect the fire resistance of the door or frame according to its UL rating. All products are regularly checked under a labeling and listing service. The clearance between the door and the frame and between the meeting edges of doors swinging in pairs shall be 1/8" ± 1/16" (3.18 mm ± 1.59 mm) for steel doors and shall not exceed 1/8" (3.2 mm) for wood doors.

- UL 10C (Positive Pressure) complies with IBC, NFPA 80 and NFPA 252 for hollow metal fire doors rated up to 3 hours and wood fire doors rated up to 90 minutes.
- UL 10B complies with NFPA 80 and NFPA 252 for hollow metal fire doors rated up to 3 hours and wood fire doors rated up to 90 minutes.

Notes: Ratings on some items may vary and are noted on the individual products. For a more complete look at classifications on individual products, please visit [www.ul.com/database](http://www.ul.com/database) and reference R13647.



## GENERAL INFORMATION

### THE INTERNATIONAL BUILDING CODE (IBC)

The International Building Code (IBC) requires swinging fire doors to be tested in accordance with ANSI/UL 10C or NFPA 252, with the neutral pressure level established at 40 inches or less above the sill. This causes "positive pressure" forces against the door assembly above 40 inches.

The result is hot gases and smoke leak out between the door and frame above this level, posing a serious threat to life-safety; and on wood doors rapidly deteriorating the integrity of the door edges, requiring either a built-in or supplemental "edge sealing system" to pass the test.

Fire door assemblies in corridors and smoke barrier walls are required to be smoke and draft control assemblies tested in accordance with UL1784 allowing a maximum air leakage of 3 cubic feet per minute per square foot of door opening at ambient temperature (75°F) and elevated temperature (400°F). These assemblies require the letter "S" on the fire rating label of the door indicating compliance "when listed or labeled gasketing is also installed."

Fire doors are classified based upon their construction and edge sealing system requirements. Fire-rated gasketing is classified as follows:

**Category G** - Edge-sealing system

**Category H** - Smoke and draft control gasketing

**Category J** - Gaskets other than category G or H

#### Fire Test - Category G

Gaskets that are edge-sealing systems. Category "G" - edge-sealing systems are for use with fire doors requiring an edge seal to meet positive pressure code requirements. These systems are surface-applied to either the perimeter of the door frame or meeting edges of door pairs. Category "G" gaskets are usually intumescent material; this material will swell many times its original size during a fire and help contain the spread of fire by sealing the edges of the door.

#### Fire Test - Category J

Products that are positive pressure tested to determine that they do not contribute to flaming during a fire; they do not provide an edge-sealing system. Examples are gaskets used for sound, draft control or automatic door bottoms.

#### Smoke and Draft Control Test - Category H



This is a separate second test that does not involve fire. All gaskets being tested for smoke must initially be fire tested under the requirements of UL 10C and receive a category "G" or "J" rating before being smoke tested.

Below are some key phrases that indicate positive pressure requirements:

- IBC 2003 (and later) - International Building Code
- UL 10-C - Positive Pressure Fire Test
- ASTM E-2074-00 - Fire Test of Door Assemblies
- Shall meet positive pressure requirements
- Intumescent seals - imply positive pressure

The [www.iccsafe.org](http://www.iccsafe.org) web site of the International Code Council (ICC) has a map of code adoption by state. This site is frequently updated and by clicking on a state, you can see what codes they have adopted.

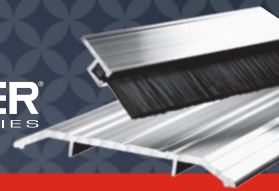

## GENERAL INFORMATION

### New and existing fire doors are classified/labeled by one of the following designation systems:

-  Hourly rating designation    
  Alphabetical letter designation    
  A combination of both

### Common Applications for Hager Positive Pressure Edge Sealing & Smoke Seal Systems



Wall Rating	Door and Frame Rating	Door Application and Use	Door Types		Fire Doors Edge Sealing System	Smoke Doors "S" Label Smoke Seal	Fire & Smoke Doors Combination Seal
4 Hr.	3 Hour (A Label) 180 Minute	Openings in fire walls and walls that divide a single building into fire areas	Hollow Metal Hollow Metal	Pairs Singles	— —	721, 726, 736, 737 721, 726, 736, 737	— —



2 Hr.	1 1/2 Hour (B Label) 90 minute	Openings to stairwells and elevator shafts; vertical communication or egress through a building, including 2-hr. rated partitions providing horizontal fire separations	Wood Composite Hollow Metal Wood Composite Hollow Metal	Pairs Pairs Singles Singles	724, 729 — 724, 729 —	721, 726, 736, 737 721, 726, 736, 737 721, 726, 736, 737 721, 726, 736, 737	719, 720, 722, 734 — 719, 720, 722, 734 —
-------	-----------------------------------	---	--	--------------------------------------	--------------------------------	--	--



2 Hr.	1 1/2 Hour (D Label) 90 minute	Opening where there is a chance of severe fire exposure from the exterior of the building	Hollow Metal Hollow Metal	Pairs Singles	— —	721, 726, 736, 737 721, 726, 736, 737	— —
-------	-----------------------------------	---	------------------------------	------------------	--------	--	--------



1 Hr.	*1 Hour (B Label) 60 Minutes	Doors that divide occupancies in a building (building less than 4 stories tall)	Wood Wood	Pairs Singles	724, 729 724, 729	721, 726, 736, 737 721, 726, 736, 737	719, 720, 722, 734 719, 720, 722, 734
-------	---------------------------------	---	--------------	------------------	----------------------	--	--

\*Currently rating only applies to wood doors.



1 Hr.	3/4 Hour (E Label) 45 Minute	Opening in an exterior wall with the potential to be exposed to moderate to light fire from the outside of the building	Hollow Metal Hollow Metal	Pairs Singles	— —	721, 726, 736, 737 721, 726, 736, 737	— —
-------	---------------------------------	---	------------------------------	------------------	--------	--	--------



1 Hr.	3/4 Hour (C Label) 45 Minute	Openings in walls or partitions between rooms and corridors	Wood Composite Wood Composite	Pairs Singles	724, 729 724, 729	721, 726, 736, 737 721, 726, 736, 737	719, 720, 722, 734 719, 720, 722, 734
-------	---------------------------------	---	----------------------------------	------------------	----------------------	--	--



1 Hr.	*1/3 Hour 20 Minute	Openings in corridors where smoke and draft control is required *Does not have letter designation	Wood/Particle Core Wood/Particle Core	Pairs Singles	724, 729 724, 729	721, 726, 736, 737 721, 726, 736, 737	719, 720, 722, 734 719, 720, 722, 734
-------	------------------------	--	--	------------------	----------------------	--	--

\*All of the labels listed above have the capability of being both fire and smoke barrier openings. However, not all openings require a smoke label. Openings requiring smoke labels are detailed either by the fire authority having jurisdiction, local code, NFPA 101 or NFPA 5000.

## THRESHOLDS - SADDLE

To effectively seal out the elements, use in conjunction with a door bottom, sweep, shoe, or bumper strip.

Fasteners: #10 x 1-1/2" sheet metal screws, other screw types and anchors available upon request

Options: Available with Sure Step Non-Slip Abrasive Coating

- Notes:
- MIL finish thresholds are supplied with zinc plated screws
  - Color anodized thresholds are supplied with screws plated to match
  - Stainless steel thresholds are supplied with stainless steel screws

### 401S

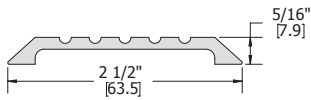

Finishes: MIL, DBA, GLD

Certifications: 

### 402S

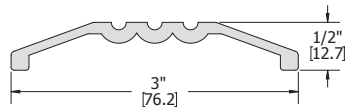

Finishes: MIL, DBA, GLD

Certifications: 

### 403S

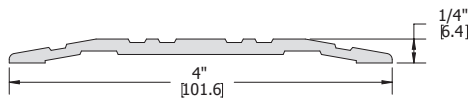

Finishes: MIL, DBA, GLD, US32D

Certifications: 

### 404S

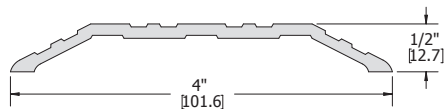

Finishes: MIL, DBA, GLD, US32D

Certifications: 

### 410S

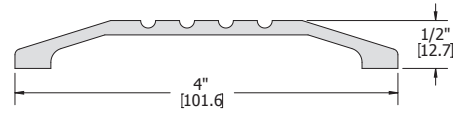

Finishes: MIL, DBA, GLD

Certifications: 

### 411S

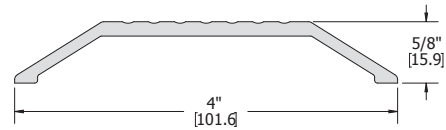

Finishes: MIL, DBA, GLD

Certifications: 

### 412S

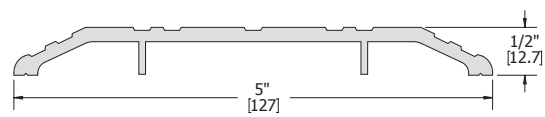

Finishes: MIL, DBA, GLD, US32D

Certifications: 

### 413S

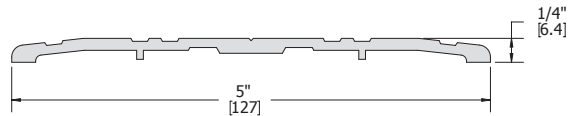

Finishes: MIL, DBA, GLD, US32D

Certifications: 

### 414S

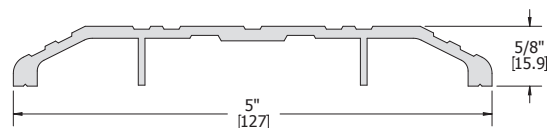

Finishes: MIL, DBA, GLD

Certifications: 

### 415S

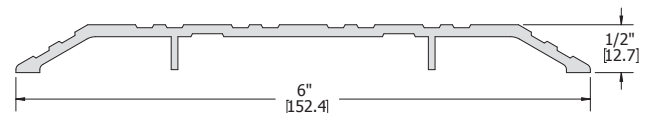

Finishes: MIL, DBA, GLD

Certifications: 



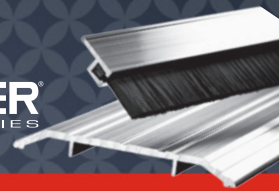

## THRESHOLDS - SADDLE

### 416S

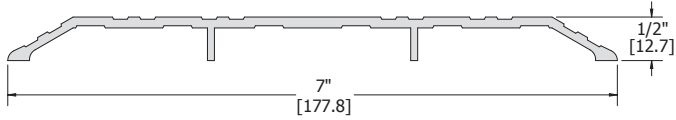

Finishes:  
Certifications:



### 428S

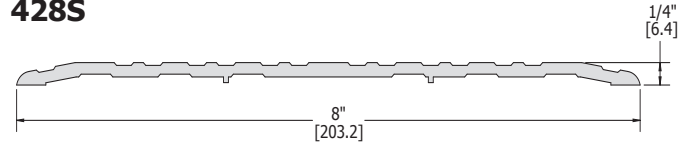

Finishes:  
Certifications:



### 417S

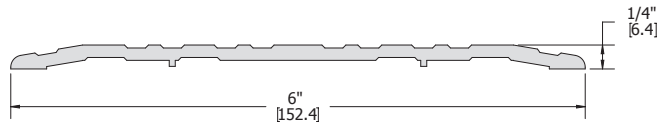

Finishes:  
Certifications:



### 430S

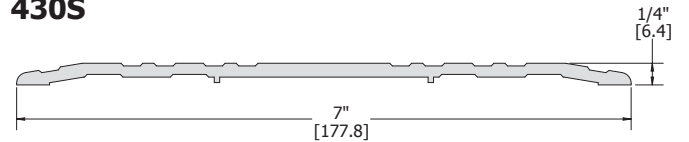

Finishes:  
Certifications:



### 418S

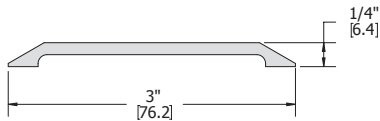

Finishes:  
Certifications:



### 436S

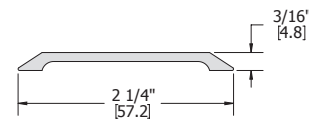

Finishes:  
Certifications:



### 426S

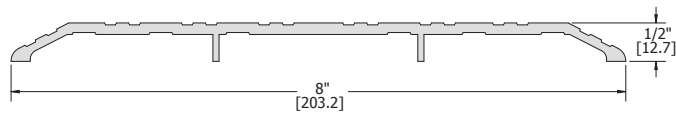

Finishes:  
Certifications:



### 448S

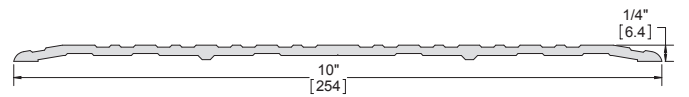

Finishes:  
Certifications:



### 427S

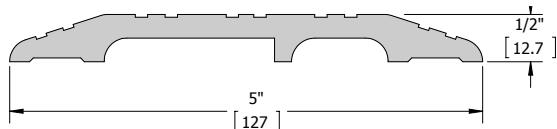

Finishes:  
Certifications:



### 492S

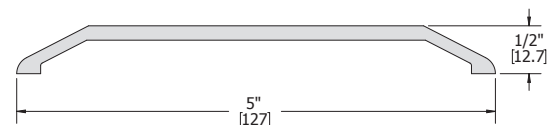

Finishes:  
Certifications:



## THRESHOLDS - THERMAL BARRIER SADDLE

High strength thermal barrier is permanently bonded in place to block the transfer of heat or cold. To provide a seal, use in conjunction with a door bottom, sweep, shoe or bumper strip.

**Fasteners:** #10 x 1-1/2" sheet metal screws, other screw types and anchors available upon request

**Options:** Available with Sure Step non-slip abrasive coating

**Notes:**

- MIL finish thresholds are supplied with zinc plated screws
- Color anodized thresholds are supplied with screws plated to match

### 420S

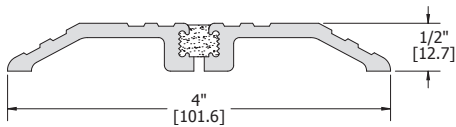

**Finishes:** MIL, DBA, GLD

**Certifications:** 

### 421S

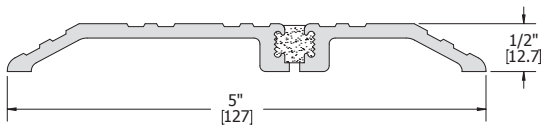

**Finishes:** MIL, DBA, GLD

**Certifications:** 

### 422S

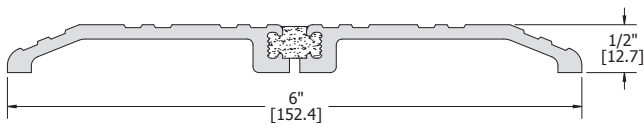

**Finishes:** MIL, DBA, GLD

**Certifications:** 

### 423S

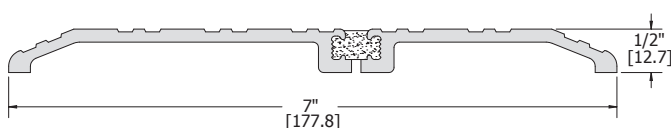

**Finishes:** MIL, DBA, GLD

**Certifications:** 

### 424S

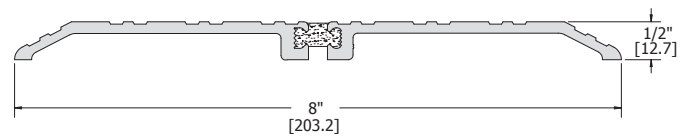

**Finishes:** MIL, DBA, GLD

**Certifications:** 

### 451S

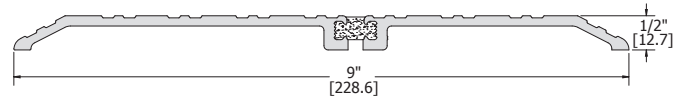

**Finishes:** MIL, DBA, GLD

**Certifications:** 

### 452S

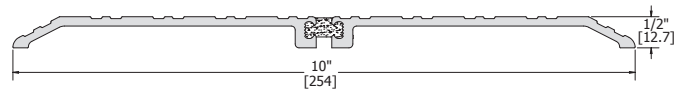

**Finishes:** MIL, DBA, GLD

**Certifications:** 



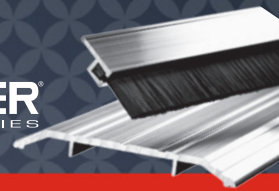

## THRESHOLDS - HALF SADDLE

Fasteners: #10 x 1-1/2" sheet metal screws, other screw types and anchors available upon request

Options: Available with Sure Step non-slip abrasive coating

Notes:
 

- MIL finish thresholds are supplied with zinc plated screws
- Color anodized thresholds are supplied with screws plated to match

### 406S

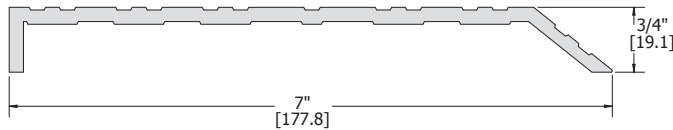

Finishes: MIL, DBA, GLD  
 Certifications: 

### 407S

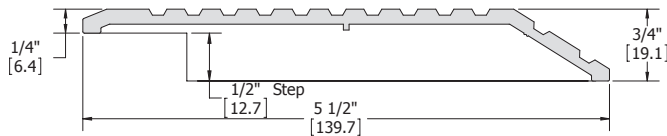

Finishes: MIL, DBA, GLD  
 Certifications: 

### 431S

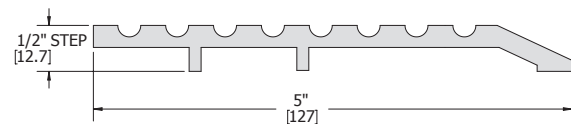

Finishes: MIL, DBA, GLD  
 Certifications:  

### 432S

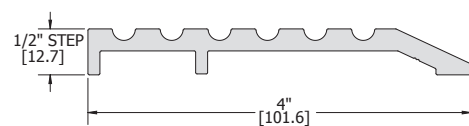

Finishes: MIL, DBA, GLD  
 Certifications:  

### 433S

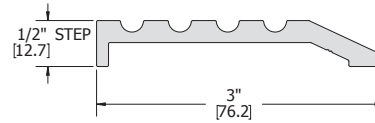

Finishes: MIL, DBA, GLD  
 Certifications:  

### 438S

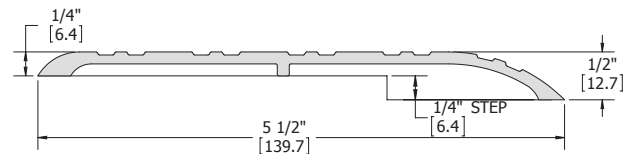

Finishes: MIL, DBA  
 Certifications:  

### 572S

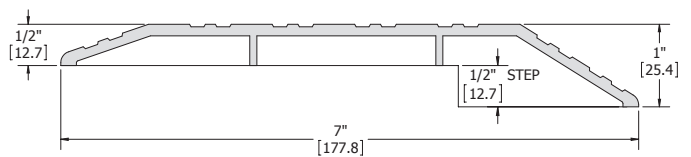

Finishes: MIL, DBA, GLD  
 Certifications: 



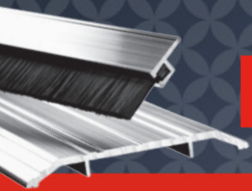

## THRESHOLDS - ELEVATOR AND BUMPER STRIPS

Use in conjunction with a threshold

Fasteners: #10 - 24 x 5/8" flat head self-tapping screws to attach bumper strip directly to an existing threshold

### 480S

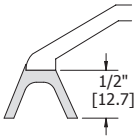

Finishes: MIL, DBA

### 481S

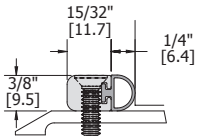

Finishes: MIL, DBA, GLD  
 Insert: V, N, S, W  
 Certifications:



### 484S

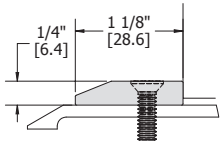

Finishes: MIL, DBA, GLD  
 Certifications:



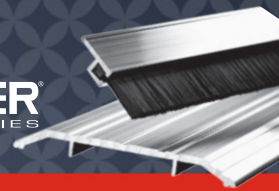

## THRESHOLDS - RESIDENTIAL

All thresholds appearing in this column are available with Sure Step Non-Slip Abrasive Coating.

### 400S

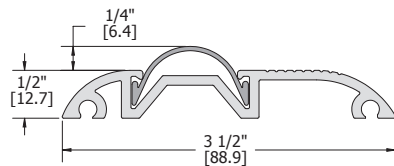

Finishes: MIL, DBA, GLD  
 Insert: V  
 Certifications: 

Notes: Vinyl gasket eliminates the need for door shoe or sweeps

### 408S

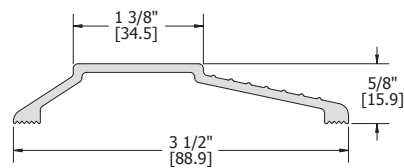

Finishes: MIL, DBA, GLD  
 Certifications: 

### 419S

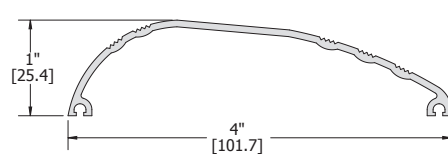

Finishes: MIL, DBA, GLD  
 Certifications: 

## THRESHOLDS - CARPET

Fasteners: #10 x 1-1/2" sheet metal screws, other screw types and anchors available upon request  
 Options: Available with Sure Step non-slip abrasive coating  
 Notes:
 

- MIL finish thresholds are supplied with zinc plated screws
- Color anodized thresholds are supplied with screws plated to match

### 503S

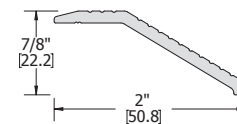

Finishes: MIL, DBA, GLD  
 Certifications: 

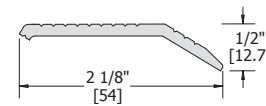

### 504S

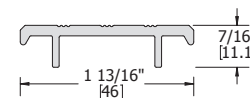

Finishes: MIL, DBA, GLD  
 Certifications: 

### 505S



Finishes: MIL, DBA, GLD  
 Certifications:  

### 506S

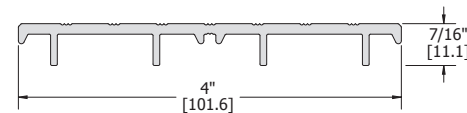

Finishes: MIL, DBA, GLD  
 Certifications:  

### 508S

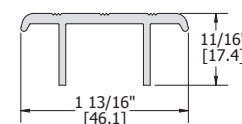

Finishes: MIL, DBA, GLD  
 Certifications: 

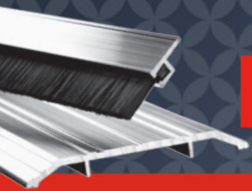

## THRESHOLDS - BUMPER

For use with outswinging doors to seal out the elements  
 Fasteners: #10 x 1-1/2" sheet metal screws, other screw types and anchors available upon request  
 Options: Available with Sure Step non-slip abrasive coating  
 Notes:
 

- MIL finish thresholds are supplied with zinc plated screws
- Color anodized thresholds are supplied with screws plated to match

### 434S

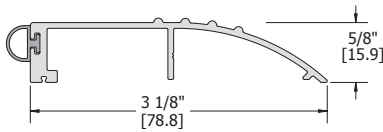

Finishes: MIL, DBA, GLD  
 Insert: V, N, S, W  
 Certifications:

### 435S

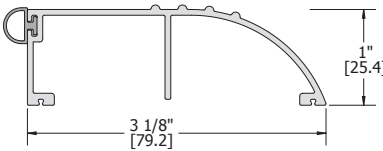

Finishes: MIL, DBA, GLD  
 Insert: V, N, S, W  
 Certifications:

### 477S

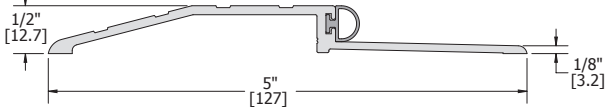

Finishes: MIL, DBA, GLD  
 Insert: V, N, S, W  
 Certifications:

### 478S

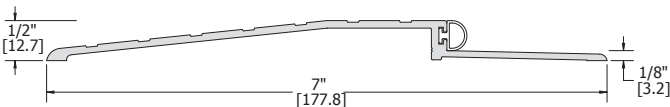

Finishes: MIL, DBA, GLD  
 Insert: V, N, S, W  
 Certifications:

## THRESHOLDS - ADA RAMP

Ramp threshold that provides a 1:12 slope to meet the requirements of the Americans With Disabilities Act

Order: To create a ramp that is a combination of the 442S and 443S, order 444S

Fasteners: #10 x 1-1/2" Flat head wood screws  
 Options: Available with Sure Step non-slip abrasive coating  
 Notes:
 

- MIL finish thresholds are supplied with zinc plated screws
- Color anodized thresholds are supplied with screws plated to match

### 442S

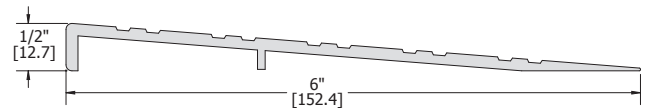

Finishes: MIL, DBA, GLD  
 Certifications:

### 443S

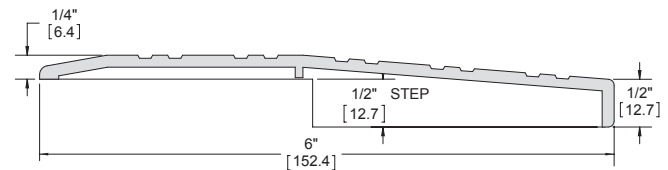

Finishes: MIL, DBA, GLD  
 Certifications:

### 444S

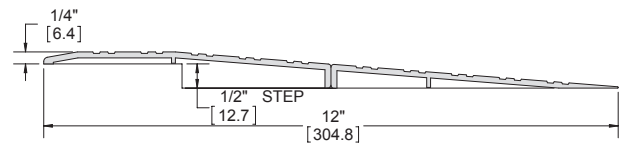

Finishes: MIL, DBA, GLD  
 Certifications:

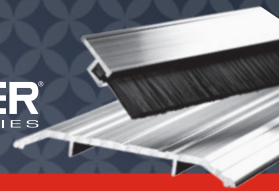

## THRESHOLDS - FLOOR PLATE ASSEMBLY

Floor plate components for modular threshold system. Used primarily for extra wide door frames or to cover expansion joints or floor joists

Fasteners: Plates and plate supports are furnished without holes and fasteners unless specified

Options:
 

- Available with Sure Step non-slip abrasive coating
- Beveled Edges are available

Notes: Plates may be used fluted or smooth side up

### Typical Applications

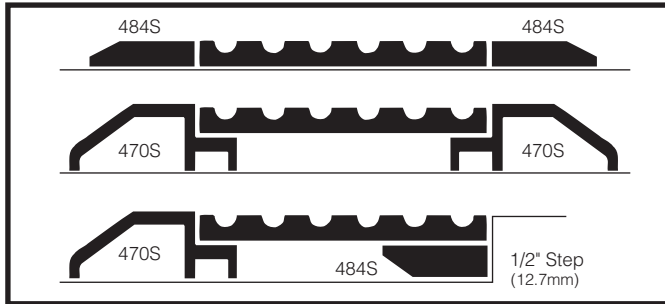

### 440S

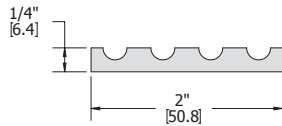

Finishes: MIL, DBA, GLD

Certifications: 

### 445S

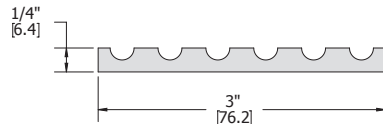

Finishes: MIL, DBA, GLD

Certifications: 

### 450S

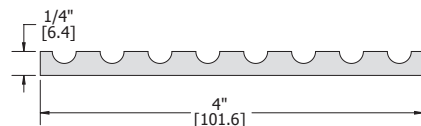

Finishes: MIL, DBA, GLD

Certifications: 

### 455S

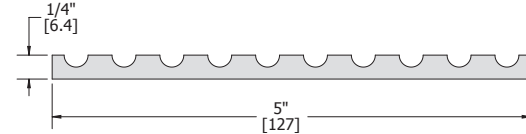

Finishes: MIL, DBA, GLD

Certifications: 

### 460S

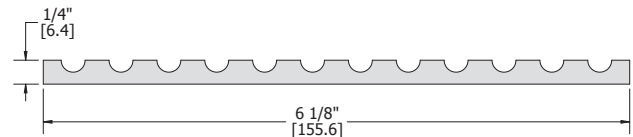

Finishes: MIL, DBA, GLD

Certifications: 

### 465S

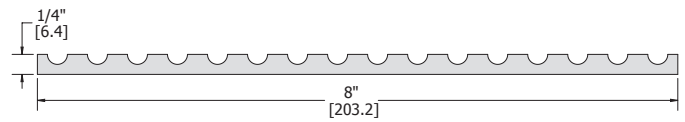

Finishes: MIL, DBA, GLD

Certifications: 

### 470S

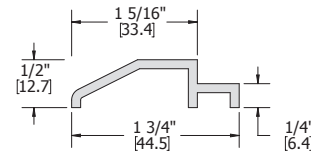

Finishes: MIL, DBA, GLD

Certifications: 

### 484S

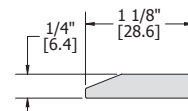

Finishes: MIL, DBA, GLD

Certifications: 

## THRESHOLDS - PANIC

- Use in conjunction with surface applied vertical rod exit device
- Fasteners: #10 x 1-1/2" flat head sheet metal screws, other screw types and anchors available upon request
- Options: Available with Sure Step non-slip abrasive coating
- Notes:
  - MIL finish thresholds are supplied with zinc plated screws
  - Color anodized thresholds are supplied with screws plated to match
  - Special under cuts may be required

### Typical Applications

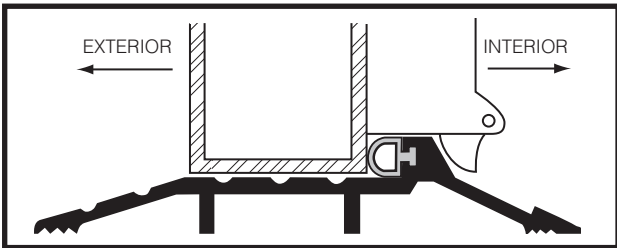

### 541S

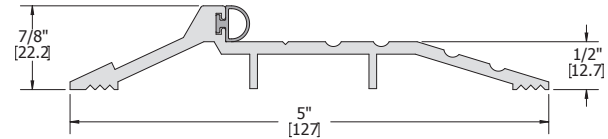

- Finishes: MIL, DBA, GLD  
 Inserts: V, N, S, W  
 Door Undercut: Allow 5/8"  
 Certifications: 

### 552S

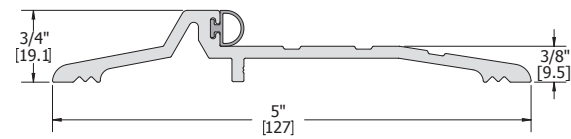

- Finishes: MIL, DBA, GLD  
 Inserts: V, N, S, W  
 Door Undercut: Allow 1/2"  
 Certifications: 

### 520S

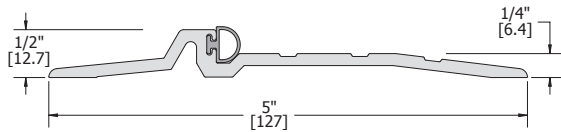

- Finishes: MIL, DBA, GLD  
 Inserts: V, N, S, W  
 Door Undercut: Allow 3/8"  
 Certifications: 

### 560S

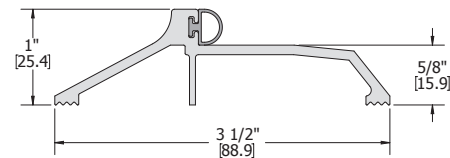

- Finishes: MIL, DBA, GLD  
 Inserts: V, N, S, W  
 Door Undercut: Allow 3/4"  
 Certifications: 

### 532S

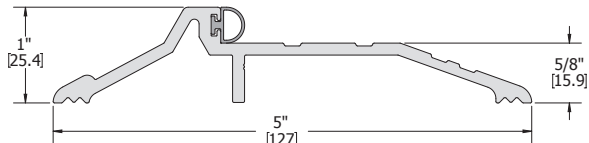

- Finishes: MIL, DBA, GLD  
 Inserts: V, N, S, W  
 Door Undercut: Allow 3/4"  
 Certifications: 

### 565S

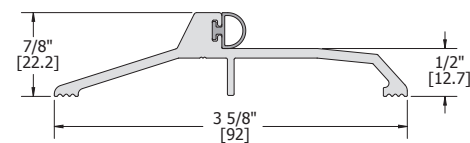

- Finishes: MIL, DBA, GLD  
 Inserts: V, N, S, W  
 Door Undercut: Allow 5/8"  
 Certifications: 



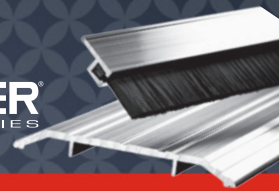

## THRESHOLDS - PANIC

### 575S

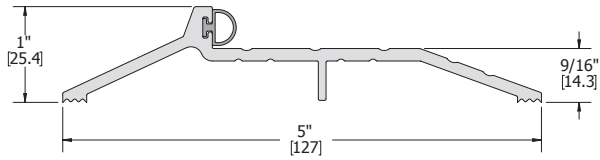

Finishes: MIL, DBA, GLD  
 Inserts: V, N, S, W  
 Door Undercut: Allow 11/16"  
 Certifications: 

### 580S

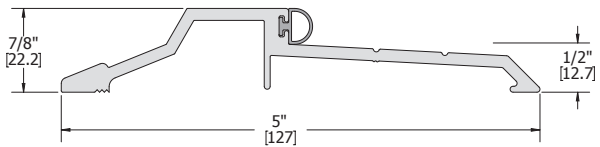

Finishes: MIL, DBA, GLD  
 Inserts: V, N, S, W  
 Door Undercut: Allow 5/8"  
 Certifications: 

### 599S

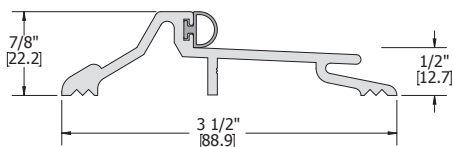

Finishes: MIL, DBA, GLD  
 Inserts: V, N, S, W  
 Door Undercut: Allow 5/8"  
 Certifications: 

## THRESHOLDS - THERMAL BARRIER PANIC

Threshold for latching panic devices that have a thermal barrier permanently bonded in place to effectively block the transfer of heat or cold. Use in conjunction with surface applied vertical rod exit device.

Fasteners: #10 x 1-1/2" Flat head sheet metal screws, other screw types and anchors available upon request

Options: Available with Sure Step non-slip abrasive coating

Notes:
 

- MIL finish thresholds are supplied with zinc plated screws
- Color anodized thresholds are supplied with screws plated to match

### 515S

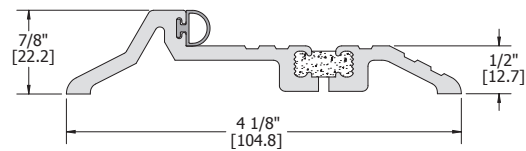

Finishes: MIL, DBA, GLD  
 Inserts: V, N, S, W  
 Certifications: 

### 516S

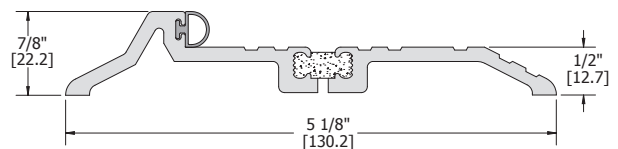

Finishes: MIL, DBA, GLD  
 Inserts: V, N, S, W  
 Certifications: 

### 517S

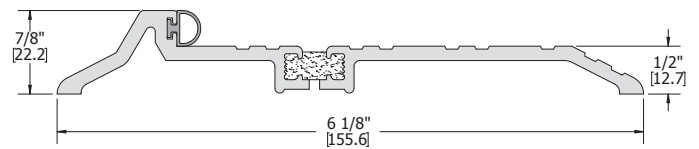

Finishes: MIL, DBA, GLD  
 Inserts: V, N, S, W  
 Certifications: 

### 518S

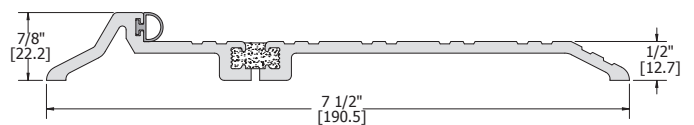

Finishes: MIL, DBA, GLD  
 Inserts: V, N, S, W  
 Certifications: 

## THRESHOLDS - INTERLOCKING

Threshold interlocks with hook on the bottom of the door for a superior seal against wind and rain

Fasteners: #10 x 1-1/2" Flat head sheet metal screws, other screw types and anchors available upon request

Options: Available with Sure Step non-slip abrasive coating

- Notes:
- MIL finish thresholds are supplied with zinc plated screws
  - Color anodized thresholds are supplied with screws plated to match
  - Thresholds are supplied with the 701S J-Hook
  - Metal doors must have flush bottom for proper J-hook installation

### 600S

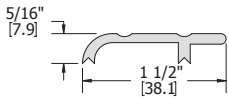

Finishes: MIL, DBA, GLD

Certifications: 

### 603S

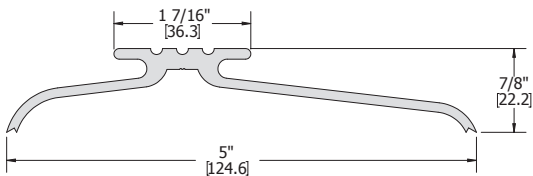

Finishes: MIL, DBA

Certifications: 

### 604S

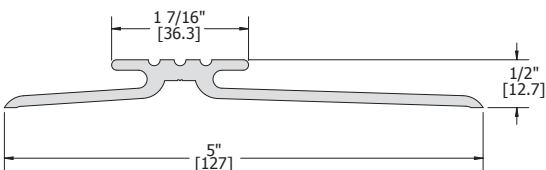

Finishes: MIL, DBA

Certifications: 

### 608S

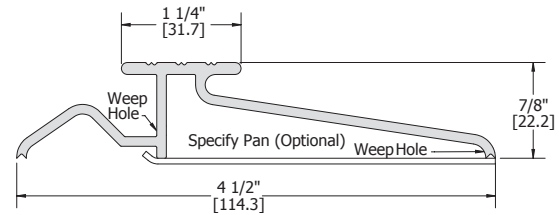

Finishes: MIL, DBA, GLD (612S only)

Certifications: 

- Notes:
- Water return feature designed to catch water and return it to the outside through weep holes
  - Optional pan keeps water from coming in contact with the floor

Order: Specify "with pan" when ordering

### 701S

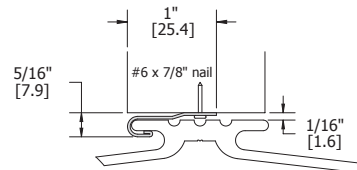

Finishes: MIL  
Fasteners: #6 x 7/8" nail

Certifications: 

- Notes:
- J-Hook interlocks with threshold to seal against wind and rain

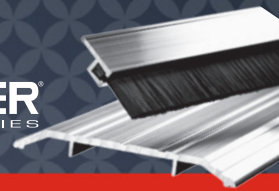

## THRESHOLDS- ABRASIVE CAST ALUMINUM

A heavy duty aluminum threshold with silicon carbide granules integrally cast into the surface. Ideal for high traffic areas where maximum durability is required. The abrasive, skid resistant surface works well under wet, dry or oily conditions.

Fasteners: #1/4" flat head zinc plated sheet metal screws with lead anchor

Options: Cast-on anchors available upon request

- Notes:
- Furnished with countersunk holes
  - Cut with a reinforced abrasive plain surface disk, 1/8" thick, either aluminum oxide or silicon carbide
  - Maximum length available is 8 feet, not available for floor closers
  - Available in 4", 5" and 6" widths

### 627S

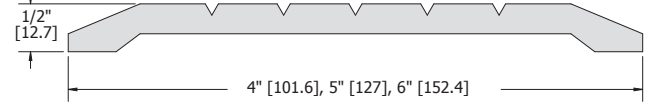

Finishes:  
Certifications:



### 621S

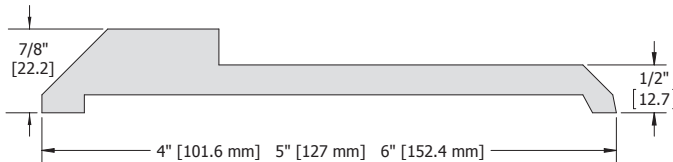

Finishes:  
Certifications:



### 622S

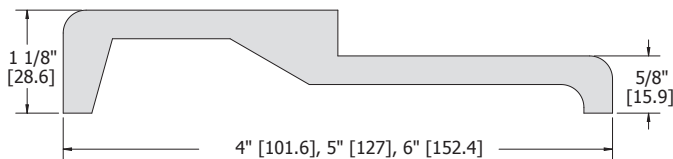

Finishes:  
Certifications:



### 626S

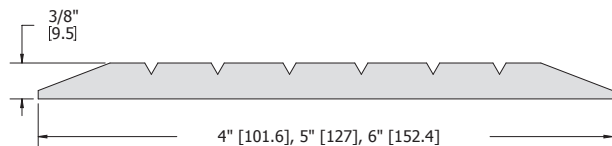

Finishes:  
Certifications:





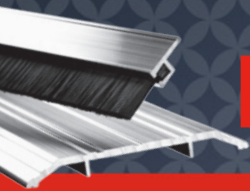

## THRESHOLDS - FLOOR CLOSER

Used with floor closers either center or offset hung, single/double door application

Fasteners: #10 x 1-1/2" flat head sheet metal screws, other screw types and anchors available upon request

Options: Available with Sure Step non-slip abrasive coating  
Order: Specify closer manufacturer, offset, closer model number, thickness of door, width of door opening and handing

Notes:
 

- MIL finish thresholds are supplied with zinc plated screws
- Color anodized thresholds are supplied with screws plated to match

### 651S - Center Hung

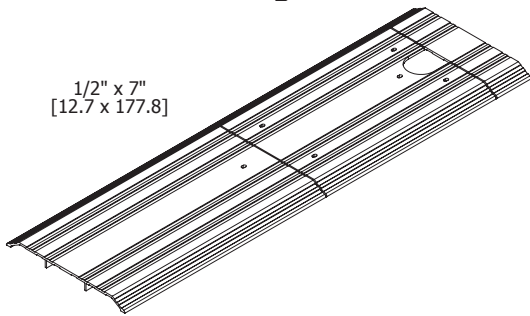

Finishes:  
Certifications:

MIL, DBA



Notes:

- Center hung
- Without mitered ends

### 652S - Center Hung

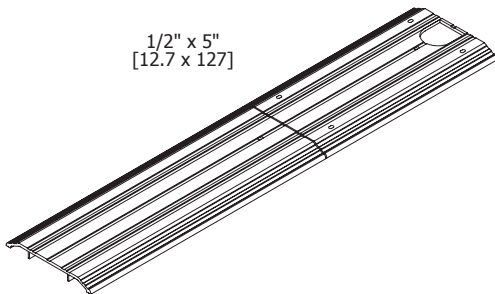

Finishes:  
Certifications:

MIL, DBA



Notes:

- Center hung
- Without mitered ends

### 653S - Offset Hung

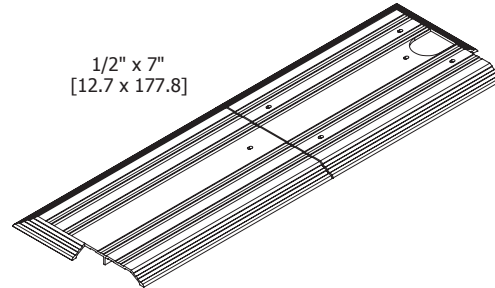

Finishes:  
Certifications:

MIL, DBA



Notes:

- Offset hung
- With mitered ends

### 654S - Center Hung

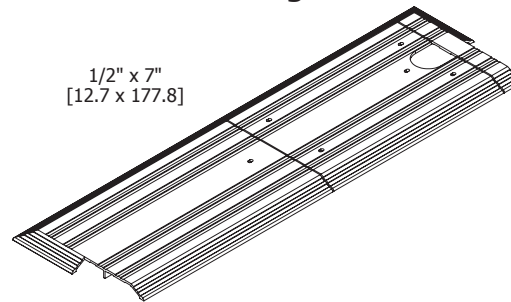

Finishes:  
Certifications:

MIL, DBA



Notes:

- Center hung
- With mitered ends

### 655S - Offset Hung

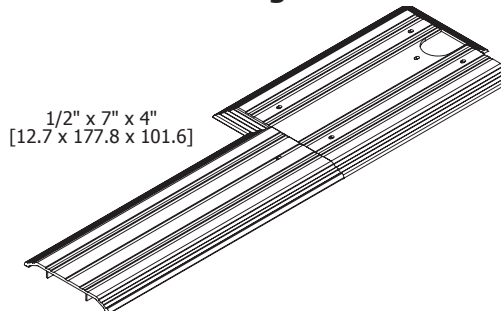

Finishes:  
Certifications:

MIL, DBA



Notes:

- Offset hung
- With mitered ends



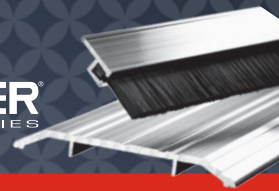

## THRESHOLDS - COVER PLATES

Cover Plates are used primarily to cover expansion joints and for situations requiring extra width or strength. Manufactured from solid cold rolled aluminum for extra durability.

Fasteners: Furnished without holes and fasteners unless specified

Notes:
 

- Available to 96" in length
- Furnished with both edges beveled

### 676S

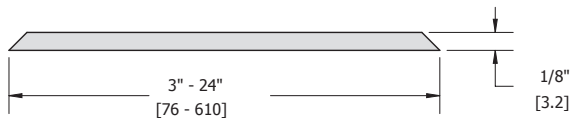

Finishes:  
Certifications:



### 677S

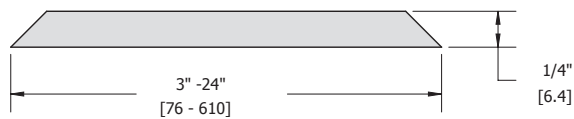

Finishes:  
Certifications:



## THRESHOLD ANCHORS

Threshold Anchors provide a fully adjustable anchor for concrete installation. Special locking nut assemblies can be positioned to accommodate various mounting hole spacings.

Order: Specify 1/4"-20 mounting holes for any threshold intended for use with the 619S

Fasteners: 1/4"-20 flat head screws and locking nut assembly per foot of anchor

### 619S

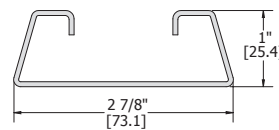

Finishes: MIL

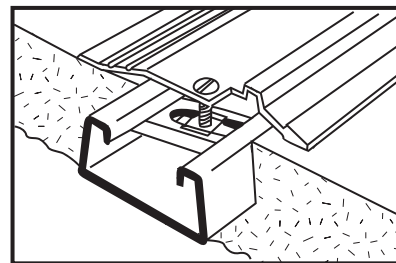

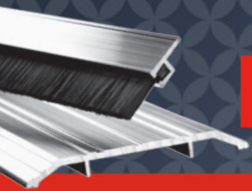

**WEATHERSTRIPPING - INTERLOCKING/OVERHEAD DRIP GUARDS**

Fasteners: #6 x 5/8" pan head sheet metal screws

**717S**

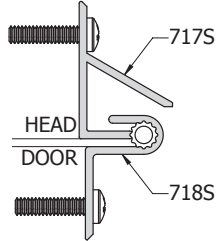
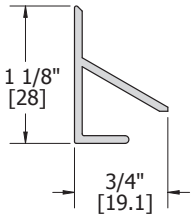

Finishes:  
Certifications:

MIL, DBA  

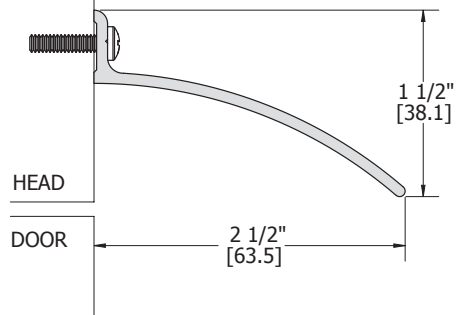

**810S**



Finishes:  
Certifications:

MIL, DBA, GLD  

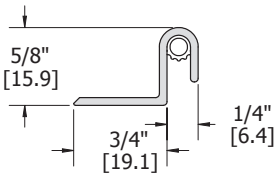

**718S**



Finishes:  
Inserts:  
Certifications:

MIL, DBA, GLD  
 V  

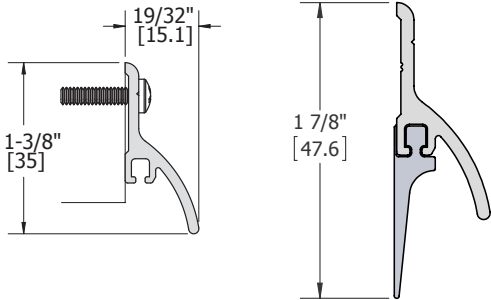
**770S**



Finishes:  
Inserts:  
Category:  
Certifications:

MIL, DBA, GLD  
 B, V, or without insert  
 H, J (with insert)  



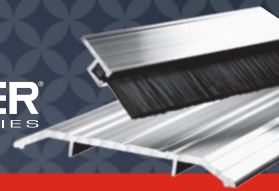

## WEATHERSTRIPPING - PRESS-ON GASKETING

### Combination Edge-Sealing System with Smoke Control

Field applied edge-sealing system gaskets with integrated smoke fin. Add to the frame of a B, C or 1/3 hour labeled fire door.

#### 719

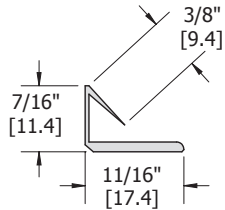

Finishes: Charcoal, Brown, Gray, Tan, White

Category: H, G, J

Certifications:



Notes:

- Requires 1/8" clearance
- Not recommended for door frames with 1/2" stop or less
- Recommend 3/16" backset - door side hinge
- Intumescent material
- Thermoplastic Elastomer (TPE) material

#### 720

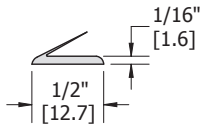

Finishes: Charcoal, Brown, Gray, Tan, White

Category: H, G, J

Certifications:



Notes:

- Thin design for doors and frames with tight tolerances
- Intumescent material
- Thermoplastic Elastomer (TPE) material

#### 722

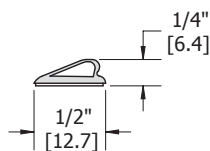

Finishes: Charcoal, Brown, Tan, White

Category: H, G, J

Certifications:



Notes:

- Requires 1/8" clearance.
- Recommend 3/16" backset - door side hinge
- Intumescent material
- Thermoplastic Elastomer (TPE) material

#### 734

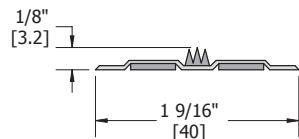

Finishes: Charcoal, Brown, Tan, White

Category: H, G, J

Certifications:



Notes:

- Intumescent material
- Thermoplastic Elastomer (TPE) material

### Edge-Sealing Systems

Field applied edge-sealing system gaskets. Add to the frame of a B, C or 1/3-hour labeled fire doors to comply with positive pressure requirements.

#### 724

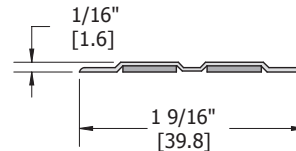

Finishes:

Category:

Certifications:

Charcoal, Brown, Gray, Tan, White

G



Notes:

- Intumescent material
- Thermoplastic Elastomer (TPE) material

#### 729

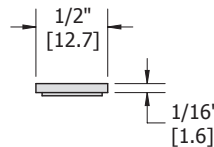

Finishes:

Category:

Certifications:

Charcoal, Brown, Gray, Tan, White

G



Notes:

- Intumescent material
- Thermoplastic Elastomer (TPE) material





## WEATHERSTRIPPING - PRESS-ON GASKETING

### Smoke Seal Systems

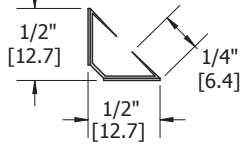
Add to the frame of a smoke rated opening to comply with the requirements of NFPA 105 and UL1784. The addition of a smoke seal is necessary to complete installation instructions and validate the "S" label of a smoke control door.

#### 721



Finishes: Charcoal, Brown, Gray, Tan, White  
 Category: H, J  
 Certifications:       
 Notes: Thermoplastic Elastomer (TPE) material



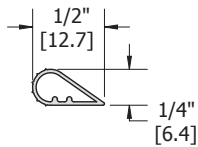

#### 726

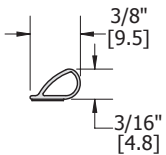

Finishes: Charcoal, Brown, Tan, White  
 Category: H, J  
 Certifications:       
 Notes: Silicone material





#### 736

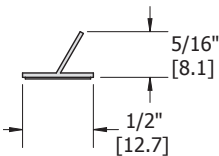

Finishes: Charcoal, Tan, White  
 Category: H, J  
 Certifications:      
 Notes: Silicone material

#### 737



Finishes: Charcoal, White  
 Category: H, J  
 Certifications:      
 Notes: Silicone material

### Draft Control Gaskets

#### 725

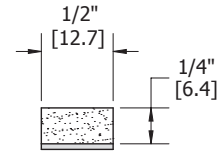

Finishes: Charcoal  
 Category: J  
 Certifications:   
 Notes: Sponge neoprene material

#### 727

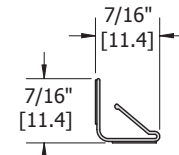

Finishes: Charcoal  
 Category: J  
 Certifications:   
 Notes: Thermoplastic Elastomer (TPE) material

#### 728

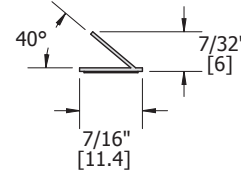

Finishes: Charcoal, White  
 Category: J  
 Certifications:   
 Notes: Silicone material

#### 738

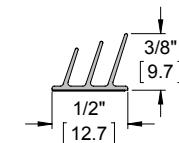

Finishes: Charcoal  
 Category: J  
 Certifications:   
 Notes: Silicone material



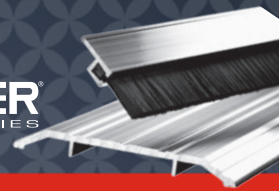

## WEATHERSTRIPPING - DOOR BOTTOMS

Provides a seal against weather. For best results, use in conjunction with a threshold.

Fasteners: #6 x 5/8" pan head sheet metal screws

Notes:

- Lengths up to 48" are supplied 1/2" over their stated size to allow for fitting
- Lengths over 48" are supplied 1" over size
- "Cut to exact length," may be specified
- Constructed of strong extruded 6063-T5 aluminum

### 751S

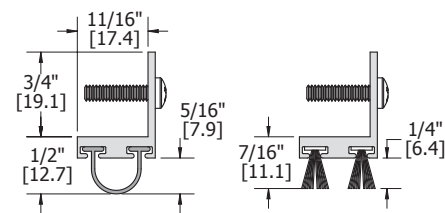

Finishes: MIL, DBA, GLD  
 Inserts: V, N, S, W  
 Category: H, J  
 Certifications: 

### 772S

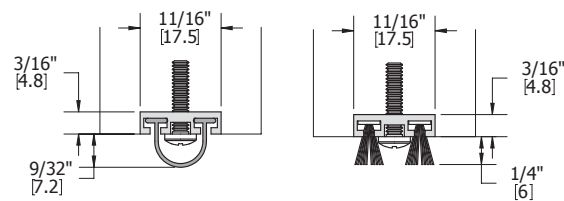

Finishes: MIL, DBA, GLD  
 Inserts: V, N, S, W  
 Category: H, J  
 Certifications: 

### 774S

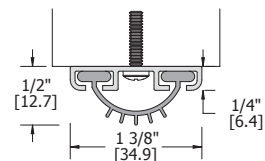

Finishes: MIL, DBA  
 Inserts: V, N  
 Category: H, J  
 Certifications: 

### 776S

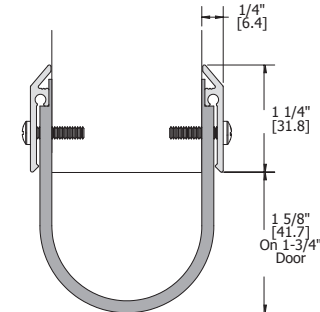

Finishes: CLR, DBA, GLD  
 Inserts: N  
 Category: H, J  
 Certifications: 

### 777S

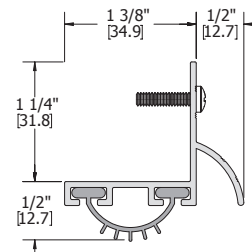

Finishes: MIL, DBA, GLD  
 Inserts: V, N  
 Category: H, J  
 Certifications: 

### 778S

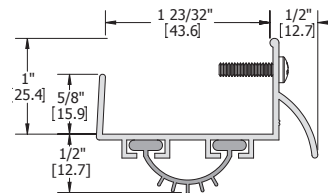

Finishes: MIL, DBA, GLD  
 Inserts: V, N  
 Category: H, J  
 Certifications: 

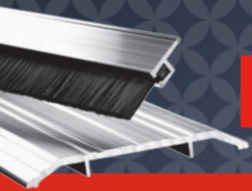

# WEATHERSTRIPPING - DOOR BOTTOMS

## 779S

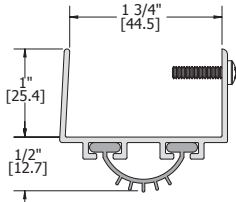

Finishes: MIL, DBA, GLD  
 Inserts: V, N  
 Category: H, J  
 Certifications:

## 783S

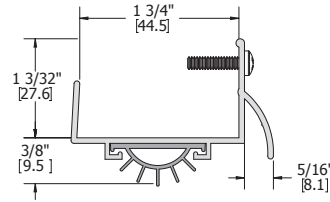

Finishes: MIL, DBA, GLD  
 Inserts: V  
 Category: J  
 Certifications:

## 780S

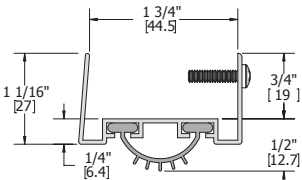

Finishes: MIL, DBA, GLD  
 Inserts: V, N  
 Category: H, J  
 Certifications:

## 787S

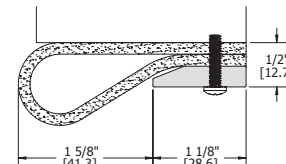

Finishes: MIL  
 Inserts: N  
 Category: H, J  
 Certifications:

## 782S

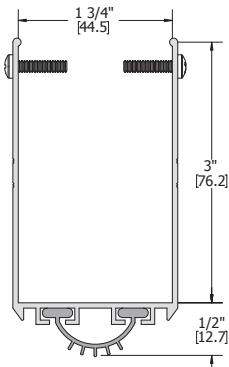

Finishes: MIL, DBA, GLD  
 Inserts: V, N  
 Category: H, J  
 Certifications:

## 789S

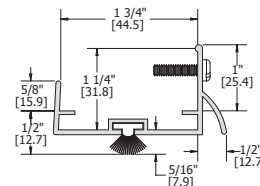

Finishes: MIL, DBA, GLD  
 Inserts: W  
 Category: H, J  
 Certifications:

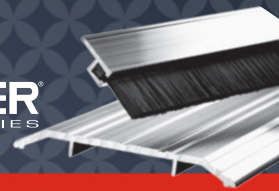

## WEATHERSTRIPPING - AUTOMATIC DOOR BOTTOMS

Provides an outstanding seal against drafts, light, smoke and sound. For best results, use in conjunction with a threshold. When door fully closes, the gasket extends downward to provide a seal. Gasket retracts when door is opened.

Fasteners:

- #8 x 1-1/4" pan head sheet metal screws furnished with surface mount types
- #6 x 5/8" Pan head sheet metal screws furnished with mortise types

Notes:

- Furnished exact length as stated. May be trimmed for fitting (2" maximum).
- Furnished with end cover and strike plates
- DBA/GLD end caps available on MIL or CLR devices (Not available on 742S)

### 742S - Mortise

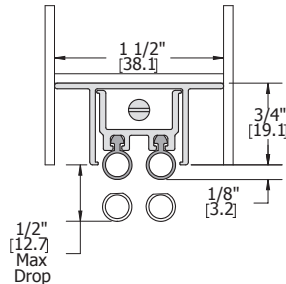

Finishes:  
Inserts:  
Category:  
Certifications:

MIL  
N, V  
J



Notes:

For use on hollow metal door

### 730S - Mortise

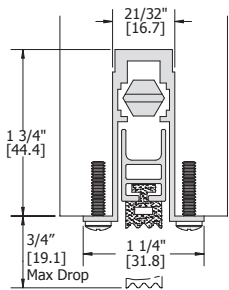

Finishes:

MIL

Inserts:

N, S

Category:

H, J

Certifications:



### 743S - Mortise

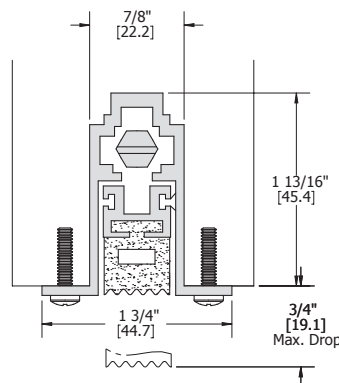

Finishes:  
Inserts:  
Category:  
Certifications:

MIL  
N  
H, J



### 747S - Surface

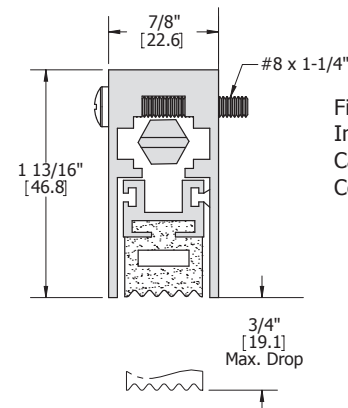

Finishes:  
Inserts:  
Category:  
Certifications:

CLR, DBA, GLD  
N  
H, J



### 740S - Surface

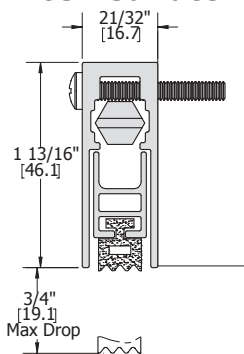

Finishes:

DBA, GLD, CLR

Inserts:

N, S

Category:

H, J

Certifications:





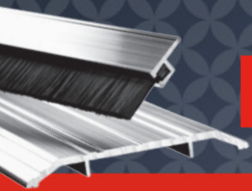

## WEATHERSTRIPPING - DOOR BOTTOM SWEEPS

Typically door bottom sweeps are used on the exterior of an outswing door  
 Fasteners: #6 x 5/8" pan head sheet metal screws furnished with mortise types

- Notes:
- MIL finish weatherstripping is supplied with zinc plated screws
  - Color anodized weatherstripping is supplied with screws plated to match
  - Stainless steel weatherstripping is supplied with stainless steel screws

### 750S

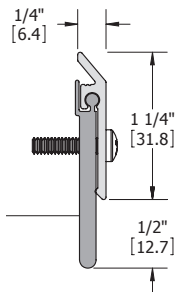

Finishes: DBA, GLD, CLR, US32D  
 Inserts: N, S  
 Category: H, J

Certifications:

### 752S

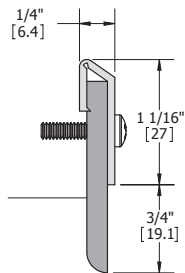

Finishes: MIL, DBA, GLD  
 Inserts: V  
 Category: H, J

Certifications:

### 753S

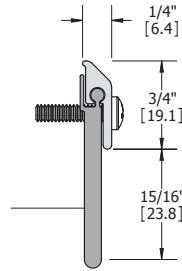

Finishes: MIL, DBA, GLD  
 Inserts: N  
 Category: H, J

Certifications:

### 754S

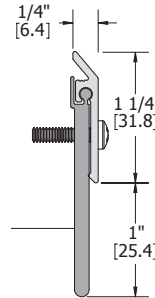

Finishes: DBA, GLD, CLR  
 Inserts: N  
 Category: H, J

Certifications:

### 756S

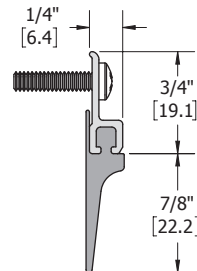

Finishes: MIL, DBA, GLD  
 Inserts: V  
 Category: H, J

Certifications:



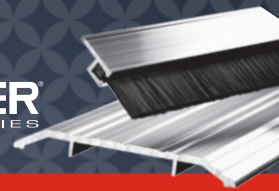



## WEATHERSTRIPPING - DOOR BOTTOM SWEEPS

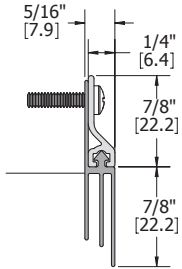

### 759S



Finishes: MIL, DBA, GLD  
 Inserts: V  
 Category: H, J  
 Certifications:  

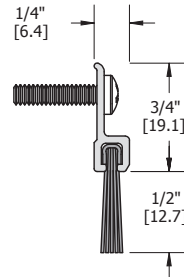

### 802S

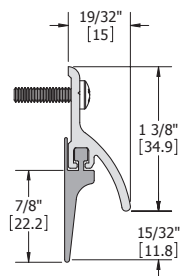

Finishes: MIL, DBA, GLD  
 Inserts: B  
 Category: H, J  
 Certifications:   

### 770S



Finishes: MIL, DBA, GLD  
 Inserts: B, V  
 Category: H, J  
 Certifications:  

### 806S

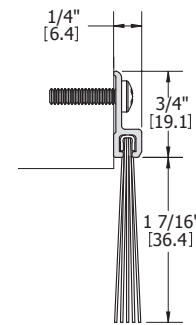

Finishes: MIL, DBA, GLD  
 Inserts: B  
 Category: H, J  
 Certifications: 

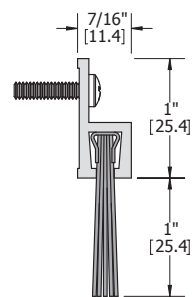

### 801S

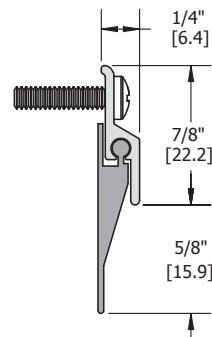

Finishes: MIL, DBA, GLD  
 Inserts: B  
 Category: H, J  
 Certifications: 

### 872S



Finishes: DBA, GLD, CLR, US32D\*  
 Inserts: N  
 Category: H, J  
 Certifications:  

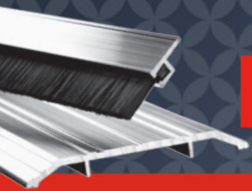

\*US32D will be supplied with grey Neoprene as opposed to the standard black



**WEATHERSTRIPPING - DOOR BOTTOM SWEEPS**

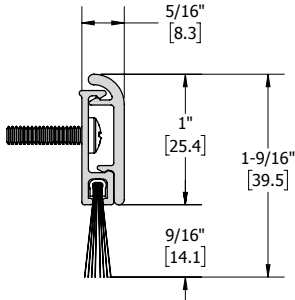

**882S**

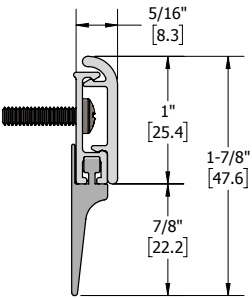

Finishes: DBA, GLD, CLR  
 Inserts: B  
 Category: H, J  
 Certifications:  

**884S**



Finishes: DBA, GLD, CLR  
 Inserts: V  
 Category: H, J  
 Certifications:  



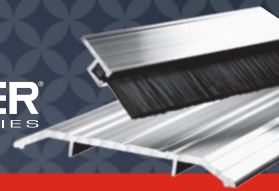

## WEATHERSTRIPPING - JAMB WEATHERSTRIPPING

- Fasteners: #6 x 5/8" pan head sheet metal screws
- Notes:
- MIL finish weatherstripping is supplied with zinc plated screws
  - Color anodized weatherstripping is supplied with screws plated to match
  - Stainless steel weatherstripping is supplied with stainless steel screws

### 785S

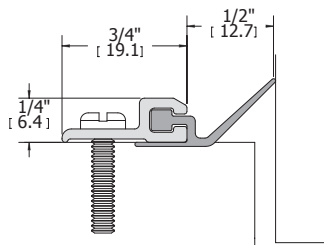

- Finishes: MIL, DBA, GLD  
 Inserts: N  
 Category: H, J  
 Certifications:



### 800S

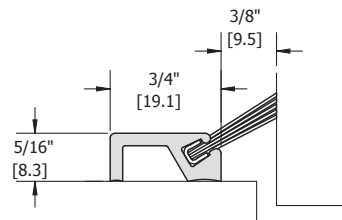

- Finishes: MIL, DBA, GLD  
 Inserts: B  
 Category: H, J  
 Certifications:



### 802S

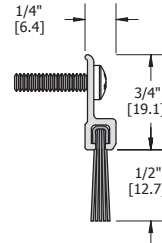

- Finishes: MIL, DBA, GLD  
 Inserts: B  
 Category: H, J  
 Certifications:



### 803S

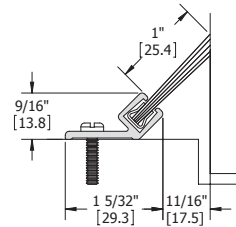

- Finishes: MIL, DBA, GLD  
 Inserts: B  
 Category: H, J  
 Certifications:



### 808S

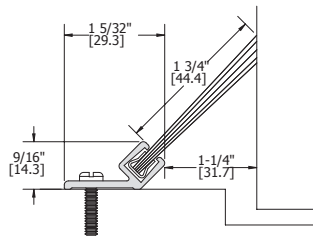

- Finishes: MIL, DBA, GLD  
 Inserts: B  
 Category: H, J  
 Certifications:



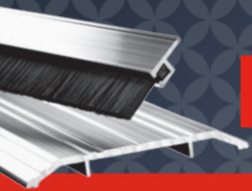

# WEATHERSTRIPPING - JAMB WEATHERSTRIPPING

## 859S

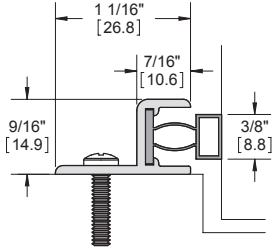

Finishes: MIL, DBA, GLD  
 Category: H, J  
 Certifications:   
 Notes: Magnetic

## 861S

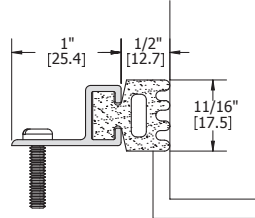

Finishes: MIL, DBA, GLD  
 Inserts: N  
 Category: H, J  
 Certifications:

## 860S

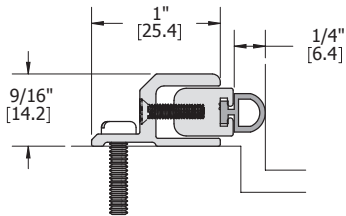

Finishes: MIL, DBA, GLD  
 Inserts: V, N, S, W  
 Category: H, J  
 Certifications:   
 Notes: Adjustable

## 862S

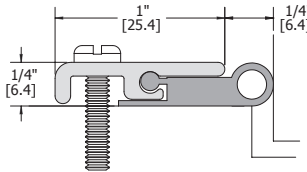

Finishes: DBA, GLD, CLR  
 Inserts: N  
 Category: H, J  
 Certifications:

## 863S

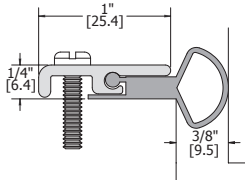

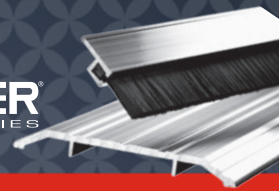

Finishes: DBA, GLD, CLR  
 Inserts: N  
 Category: H, J  
 Certifications:



## WEATHERSTRIPPING - JAMB WEATHERSTRIPPING

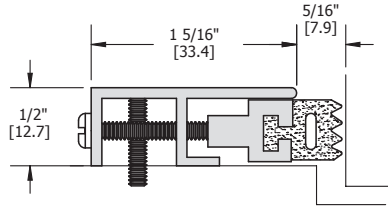

### 864S



Finishes: DBA, GLD, CLR  
 Inserts: N  
 Category: H, J  
 Certifications:    
 Notes: Adjustable

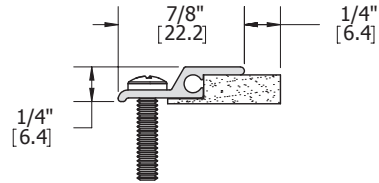

### 870S

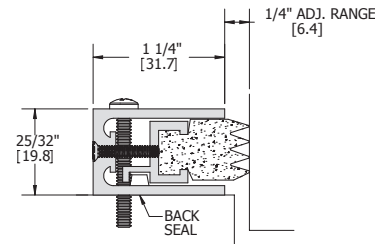

Finishes: DBA, GLD, CLR, US32D  
 Inserts: N  
 Category: H, J  
 Certifications:     
 Notes: Adjustable

### 865S



Finishes: MIL, DBA, GLD  
 Inserts: N  
 Category: H, J  
 Certifications:    
 Notes: Adjustable

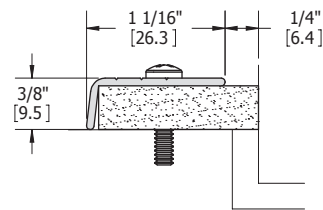

### 871S



Finishes: MIL, DBA, GLD  
 Inserts: N  
 Category: H, J  
 Certifications:  

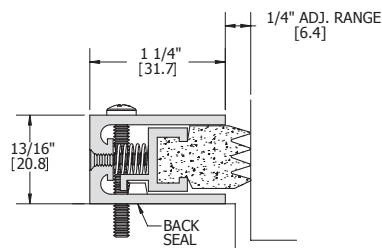

### 866S

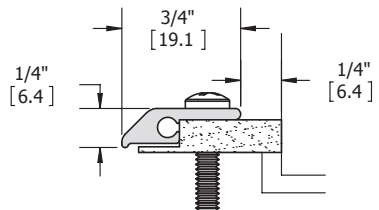

Finishes: MIL, DBA, GLD  
 Inserts: N  
 Category: H, J  
 Certifications:    
 Notes: Spring adjustable

### 873S



Finishes: MIL, DBA, GLD  
 Inserts: N  
 Category: H, J  
 Certifications:   

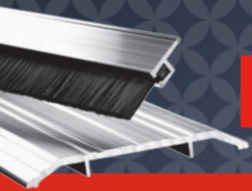

# WEATHERSTRIPPING - JAMB WEATHERSTRIPPING

## 874S

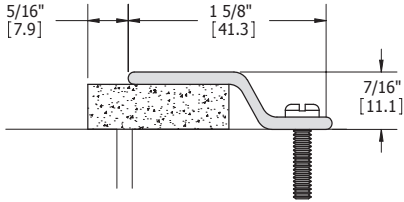

Finishes: MIL, DBA, GLD, US32D  
 Inserts: N  
 Category: H, J  
 Certifications:



## 878S

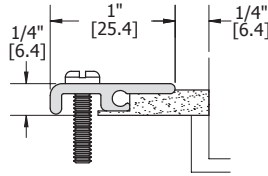

Finishes: DBA, GLD, CLR  
 Inserts: N  
 Category: H, J  
 Certifications:



## 875S

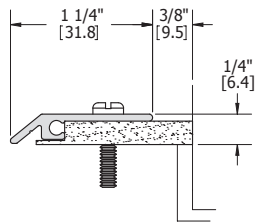

Finishes: DBA, GLD, CLR  
 Inserts: N, S  
 Category: H, J  
 Certifications:



## 880S

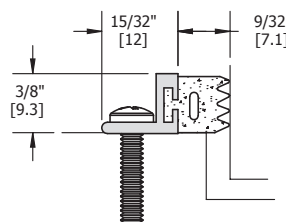

Finishes: MIL, DBA, GLD  
 Inserts: N  
 Category: H, J  
 Certifications:



## 877S

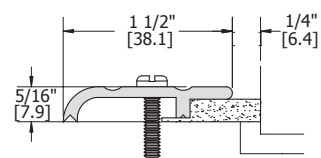

Finishes: MIL, DBA, GLD  
 Inserts: N  
 Category: H, J  
 Certifications:



## 881S

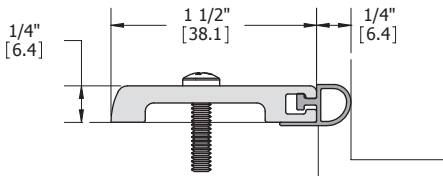

Finishes: MIL, DBA, GLD  
 Inserts: V, N, S, W  
 Category: H, J  
 Certifications:



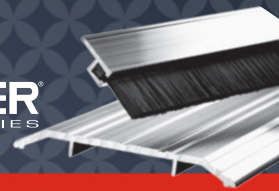

## WEATHERSTRIPPING - JAMB WEATHERSTRIPPING

### 882S

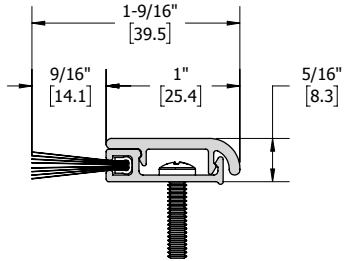

Finishes: DBA, GLD, CLR  
 Inserts: B  
 Category: H, J  
 Certifications:



### 885S

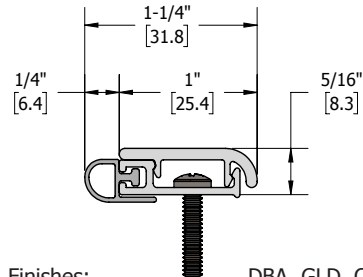

Insert "F" Shown Above

Finishes: DBA, GLD, CLR  
 Inserts: V, N, S, W, F  
 Category: H, J  
 Certifications:



### 883S

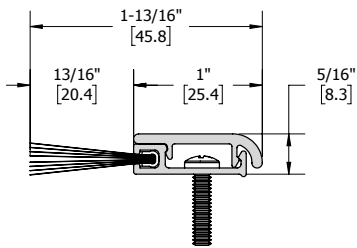

Finishes: DBA, GLD, CLR  
 Inserts: B  
 Category: H, J  
 Certifications:



### 890S

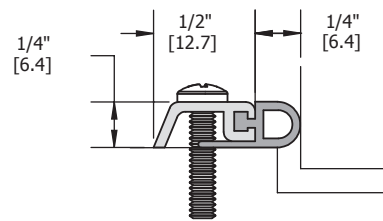

Finishes: MIL, DBA, GLD  
 Inserts: V, N, S  
 Category: H, J  
 Certifications:





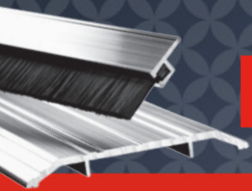

**WEATHERSTRIPPING - JAMB WEATHERSTRIPPING**

**891S**

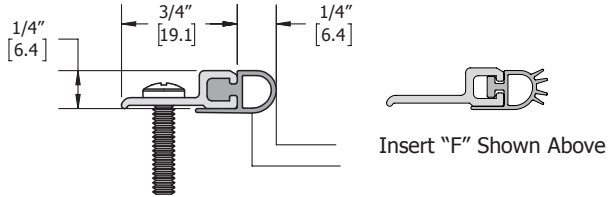

Finishes: MIL, DBA, GLD  
 Inserts: V, N, S, F  
 Category: H, J  
 Certifications:   **BHMA**  
CERTIFIED

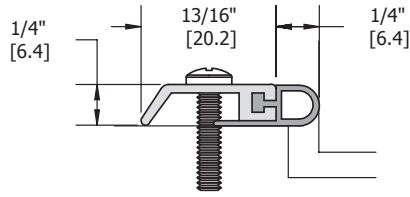

**896S**

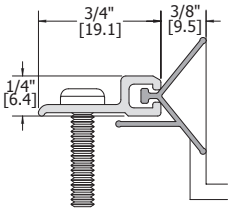

Finishes: MIL, DBA, GLD  
 Inserts: V, N, S  
 Category: H, J  
 Certifications:   **BHMA**  
CERTIFIED

**892S**



Finishes: MIL, DBA, GLD  
 Inserts: N  
 Category: H, J  
 Certifications:   **BHMA**  
CERTIFIED

**893S**

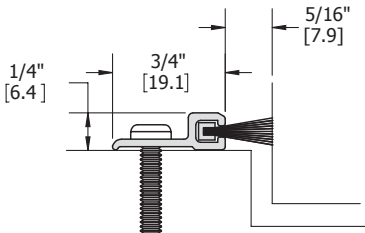

Finishes: MIL, DBA, GLD  
 Inserts: W  
 Category: J  
 Certifications:   **BHMA**  
CERTIFIED



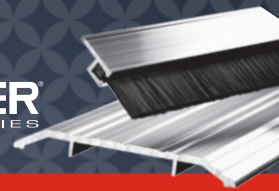

## WEATHERSTRIPPING - ASTRAGALS/MEETING STILES

Fire labeled Astragals & Meeting Stiles should only be mounted on pairs of doors with a gap that meets NFPA 80 2-3.1.7 (1/8" +/- 1/16" for steel doors and not exceeding 1/8" for wood doors)

Fasteners: #6 x 5/8" Pan head sheet metal screws

Notes:

- MIL finish weatherstripping is supplied with zinc plated screws
- Color anodized weatherstripping is supplied with screws plated to match
- Stainless steel weatherstripping is supplied with stainless steel screws

### 756S

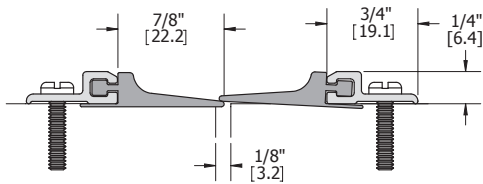

Finishes: MIL, DBA, GLD

Inserts: V

Category: H, J

Certifications:



Notes:

Order two (2) for a set

### 771S

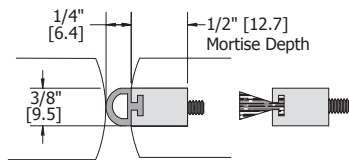

Finishes: MIL, DBA

Inserts: V, W, N, S

Category: J

Certifications:



Notes:

Order two (2) for a set

### 772S

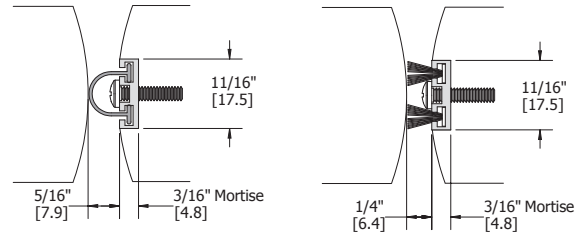

Finishes:

MIL, DBA, GLD

Inserts:

V, W, N, S

Category:

J

Certifications:



### 774S

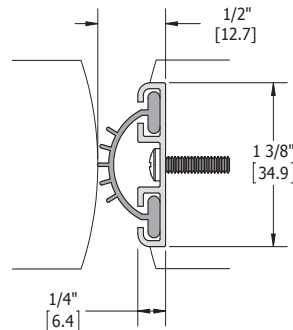

Finishes:

MIL, DBA

Inserts:

V, N

Category:

H, J

Certifications:



## WEATHERSTRIPPING - ASTRAGALS/MEETING STILES

### 776S

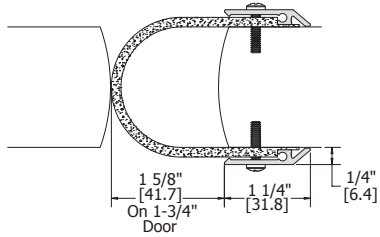

Finishes: DBA, GLD, CLR  
 Inserts: N  
 Category: H, J  
 Certifications:  

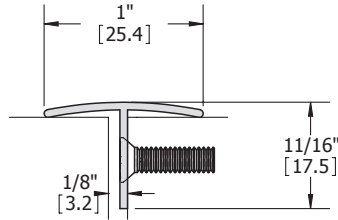

### 836S

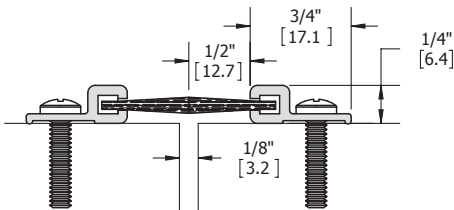

Finishes: MIL, DBA, GLD  
 Category: H, J  
 Certifications: 

### 802S



Finishes: MIL, DBA, GLD  
 Inserts: B  
 Category: H, J  
 Certifications:    
 Notes: Order two (2) for a set

### 837S

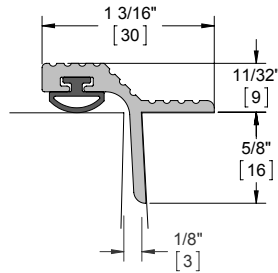

Finishes: MIL, DBA, GLD  
 Inserts: W, V, N, S  
 Category: H, J  
 Certifications:  

### 835S

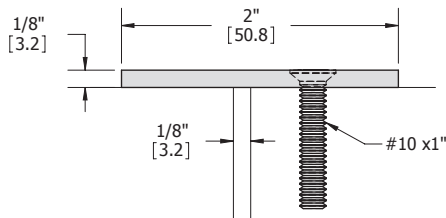



Finishes: MIL, DBA, GLD, US32D, USP  
 Category: J  
 Certifications:  

Notes:
 

- Maximum length = 10 feet
- Available with thrubolts

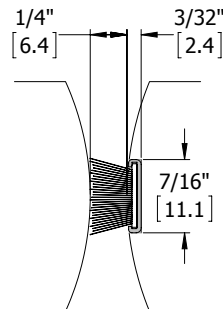
### 838S



Finishes: MIL  
 Inserts: W  
 Category: J  
 Certifications: 



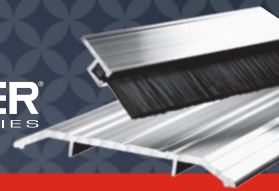

## WEATHERSTRIPPING - ASTRAGALS/MEETING STILES

### 839S

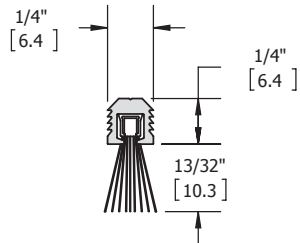

Finishes: MIL  
 Inserts: W  
 Category: J  
 Certifications: 

### 849S

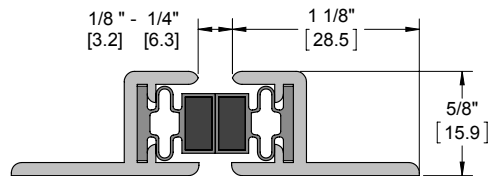

Finishes: MIL, DBA, GLD  
 Notes:
 

- Magnetic
- 96" maximum door height
- Designed for use on 80" to 96" doors only
- Sets shorter than 80" may not work properly

### 845S | 846S

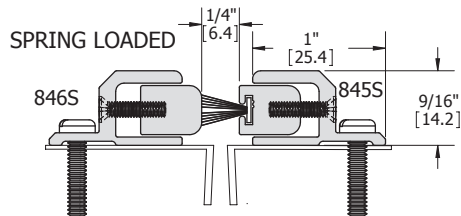



Finishes: MIL, DBA, GLD  
 Inserts: W  
 Category: J  
 Certifications: 

Notes:
 

- Adjustable
- Order two (2) for a set

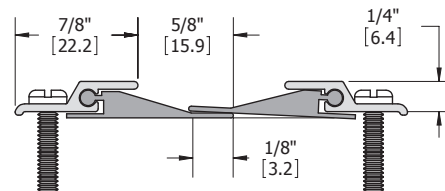
### 872S



Finishes: DBA, GLD, CLR, US32D  
 Inserts: N  
 Category: H, J  
 Certifications: 

Notes:
 

- Order two (2) for a set

### 847S | 848S

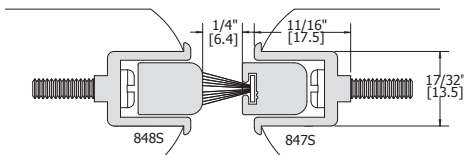

Finishes: MIL, DBA, GLD  
 Inserts: W  
 Category: J  
 Certifications: 

Notes:
 

- Adjustable
- Spring loaded
- Mortise depth = 21/32"

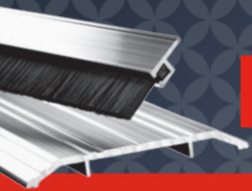

**WEATHERSTRIPPING - ASTRAGALS/MEETING STILES**

**874S**

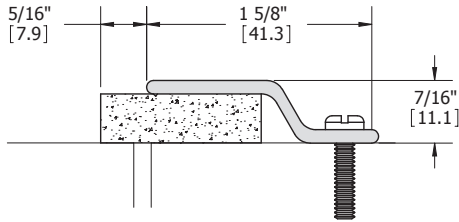

Finishes: MIL, DBA, GLD, US32D  
 Inserts: N  
 Category: H, J  
 Certifications:

**882S**

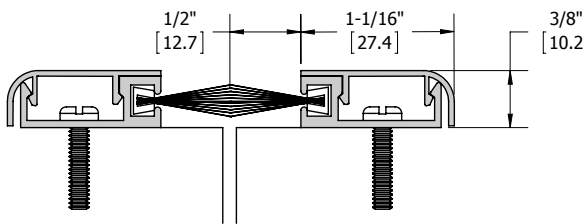

Finishes: DBA, GLD, CLR  
 Inserts: B  
 Category: H, J  
 Certifications:   
 Notes: Order two (2) for a set

**Spring Bronze**

**822S**

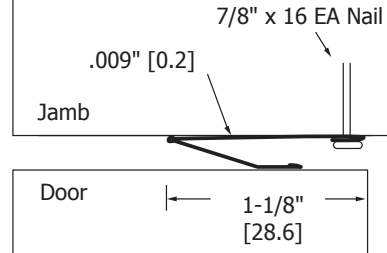

Notes:

- "V" or cushion bronze weatherstrip, for wood or metal doors
- Supplied with fasteners, specify wood or metal application
- Fasteners should be 3" on center





**One Family. One Brand. One Vision.™**

[www.hagerco.com](http://www.hagerco.com)

# Sliding Door



Hager Companies offers a full line of high quality, durable sliding door hardware that is the perfect choice for any by-pass, bi-fold, interior wall-mount, decorative barn door and pocket door application your project requires. With Hager’s sliding door hardware, you can choose from hundreds of fully tested products, including jump proof box tracks, self-aligning wheel systems, complete sets and accessories. Just as beneficial, every Hager sliding door hardware product is designed and manufactured to support a broad range of size and weight requirements, and is specified by some of the world’s most demanding architects, designers and builders – meeting or exceeding ANSI requirements.

## Table of Contents

General Information .....	2	<b>Barn Door Hardware .....</b>	<b>47</b>
<b>By-Pass .....</b>	<b>3</b>	9400 Series .....	48-52
9514 & 9583 Packaged By-Pass Sets.....	4-5	Conestoga Barn Door Hardware Series .....	53-57
9614 & 9683 Packaged Sets .....	6-7	<b>Optional Components .....</b>	<b>59-63</b>
9673 & 9674 Packaged Sets .....	8-9		
9675 & 9676 Packaged Sets .....	10-11		
9110 & 9130 Packaged Sets .....	12-13		
9611 & 9612 Packaged Sets .....	14-15		
9875 Packaged Sets .....	16-17		
9885 & 9886 Packaged Sets .....	18-19		
<b>Bi-Fold .....</b>	<b>21</b>		
9570 Track .....	22-23		
9860 & 9861 Bi-Fold Sets .....	24-25		
9890 & 9891 Packaged Sets .....	26-27		
<b>Pocket Door Kits .....</b>	<b>29</b>		
9110 & 9130 Packaged Sets .....	30-31		
9678 Pocket Door Set.....	32-33		
9878 Packaged Sets .....	34-35		
9901 Series .....	36-37		
9628   9629   9630   9631 .....	38		
9850 .....	39		
Pocket Door Components .....	40-41		
<b>Wall-Mount Hardware .....</b>	<b>43</b>		
9710 .....	44-46		





## GENERAL INFORMATION

Pg #	Max Wgt Per Door	Pkgd Sets	Track	Parts Bag	Description
<b>By-Pass</b>					
4-5	60#	9514	9810	9814	Aluminum track & hardware for 3/4" & 1-3/8" thick doors.
4-5	60#	9583	9810	9400/9401 hangers	Aluminum track & hardware for 3/4" & 1-3/8" thick doors, for 3 doors.
6-7	60#	9614	9820	9540	Aluminum track with grooved fascia & hardware for 1-3/8" thick doors.
6-7	60#	9683	9820	9401 hangers	Aluminum track with grooved fascia & hardware for 1-3/8" thick doors.
8-9	125#	9673	9603	9679	Heavy duty aluminum box track with grooved fascia & hardware for 1-3/8" & 1-3/4" thick doors.
10-14	125#	9675	9602	9679	Heavy duty aluminum box track & hardware for 1-3/8" & 1-3/4" thick doors.
14-15	150#	9611	9821	9892	Aluminum double box track & hardware for 1-3/8" & 1-3/4" thick doors.
8-9	150#	9674	9603	9680	Heavy duty aluminum box track with grooved fascia & hardware for 1-3/8" & 1-3/4" thick doors.
10-11	150#	9676	9602	9680	Heavy duty aluminum box track & hardware for 1-3/8" & 1-3/4" thick doors.
12-13	175#	9110	9101	9109	Heavy duty aluminum I-beam track and hardware for 1" thick doors and up. *Must order 2 per by pass.*
14-15	250#	9612	9821	9893	Aluminum double box track & hardware for 1-3/8" & 1-3/4" thick doors.
16-17	250#	9875	9801	9827 hangers	Heavy duty aluminum double track & hardware for 1-3/8" and 1-3/4" thick doors.
18-19	250#	9885	9803	9827 hangers	Heavy duty aluminum double track with smooth fascia & hardware for 1-3/8" & 1-3/4" thick doors.
18-19	250#	9886	9803	9827 hangers	Heavy duty aluminum double track with smooth fascia & hardware for 1-3/8" & 1-3/4" thick doors.
30-31	275#	9130	9101	9129	Heavy duty aluminum I-beam track and hardware for 1" thick doors and up. *Must order 2 per by pass.*
<b>Bi-Fold Sets</b>					
22-23	50#	9570	9601	9569	Aluminum track & hardware for 1-1/8" & 1-3/4" thick doors.
24-25	125#	9860/9850	9821	9894	Heavy duty aluminum box track & hardware for 1-3/8" & 1-3/4" thick doors.
24-25	125#	9861	9821	9894	Heavy duty aluminum box track & hardware for 1-3/8" & 1-3/4" thick doors.
26-27	125#	9890/9891	9801	9827 & 9828	Heavy duty aluminum double track & hardware for 1-1/8" and 1-3/4" thick doors.
<b>Pocket Door Sets</b>					
32-33	125#	9678	9601	9632	Heavy duty aluminum box track & hardware for 1-3/8" & 1-3/4" thick doors.
34-35	150#	9678	9101	9633	Heavy duty aluminum box track & hardware for 1-3/8" & 1-3/4" thick doors.
30-31	175#	9110	9101	9109	Heavy duty aluminum I-beam track & hardware for 1" thick doors and up.
34-35	250#	9878	9801	9742	Heavy duty aluminum double track & hardware for 1-3/8" and 1-3/4" thick doors.
36-37	250#	9901	9821	9895	Extra heavy duty aluminum box track & hardware for 1-3/8" & 1-3/4" thick doors.
30-31	275#	9130	9101	9129	Heavy duty aluminum I-beam track & hardware for 1" thick doors and up.
<b>Pocket Door Frame Kits</b>			<b>All Pocket Door Framed Kits for 1-3/8" Thick Doors</b>		
38	125#	9631	9601	9605 hangers	Pocket door packaged sets for 3'0" wide 6'8" high door
38	150#	9628	9601	9606 hangers	Pocket door packaged sets for 3'0" wide 7'0" high door
38	150#	9629	9601	9606 hangers	Pocket door packaged sets for 3'0" wide 8'0" high door
38	150#	9630	9601	9606 hangers	Pocket door packaged sets for 3'0" wide 9'0" high door
39	250#	9850	9801	9827 hangers	Pocket door packaged sets for 4'0" wide 8'0" high door
39	250#	9850	9801	9827 hangers	Pocket door packaged sets for 4'0" wide 8'6" high door
<b>Wall Mount Sets</b>					
44-46	250#	9710	9703	9711	Heavy duty aluminum track & hardware for 1" & 1-3/4" thick doors.





# By-Pass



Hager offers a full-range of trouble-free, sturdy and quiet motion by-pass Sliding Door Hardware sets. Featuring heavy-duty aluminum tracks and a selection of decor complementing fascia designs, Hager's by-pass components and door hardware sets can be ordered for 2-, 3- and 4-door configurations to fit rough openings from 4 ft to 8 ft wide.

Hager's Sliding Door Hardware sets are built to last and simple to install. They support doors from 50 lb to 275 lb capacity and offer an ideal space-saving solution for closets, pantries, room-dividing doors, etc.

By-pass door hardware is available in kits, track, or individual components.

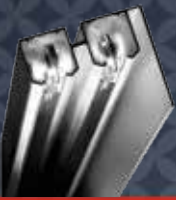

## BY-PASS - 9514 & 9583 PACKAGED BY-PASS SETS

### FEATURES

- Aluminum track with and hardware
- Conforms to ANSI A156.14
- Type: D8742

### SPECIFICATIONS

- For 3/4" - 1-3/8" (19 mm - 35 mm) thick doors
- Up to 60 lbs (27 kg) per door with single wheel hangers 9400 or 9401
- Up to 75 lbs (34 kg) per door with twin wheel hangers 9202 or 9203, sold separately
- Track is extruded aluminum jump-proof style with "V" shaped rails
- Hangers have 7/8" (22 mm) diameter wheels

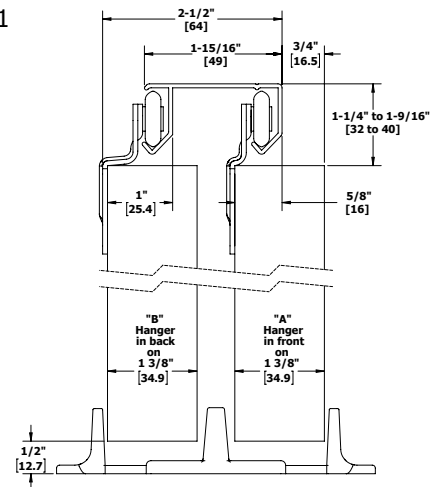
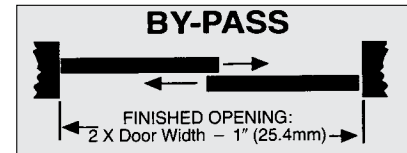

*Interchanges with Stanley 40-3230, 40-3240, 40-3260, BP60/BP75-02 and Cox 12-200 Series.*

Part Number	Description
9514 Packaged Set (for two doors)	Includes one (1) 9810 track and one (1) 9814 parts bag
9514-48	By-Pass Set - For two 24" (610 mm) doors
9514-60	By-Pass Set - For two 30" (762 mm) doors
9514-72	By-Pass Set - For two 36" (914 mm) doors
9514-96	By-Pass Set - For two 48" (1219 mm) doors
9583 Packaged Set (for three doors)	Includes one (1) 9810 track, two (2) 9400 hangers, four (4) 9401 hangers, two (2) 9353 guides, and three (3) 2610 pulls
9583-96	By-Pass Set - For three 32" (813 mm) doors

Use the chart below to select the correct hanger offset combination for your application.

Side Mount Selection Chart				
Door Thickness	3/4" (19 mm)	1" (25.4 mm)	1-1/8" (29 mm)	1-3/8" (35 mm)
Front Hanger	B	B	A or B	A
Rear Hanger	A	A	Same as front	B
Door Gap	3/4"	1/2"	11/16"	9/16"
			<b>Notes:</b>	
	<b>Item #</b>	<b>Description</b>	Hanger is stamped "A" or "B" for easy identification	
Hanger A	9200	Single wheel hanger-offset A	For consideration for 9514, 9583, 9614, 9683, 9844 and 9845 By Pass packaged sets.	
Hanger B	9201	Single wheel hanger-offset B		
Hanger B*	9202	Twin wheel hanger-offset B		
Hanger A*	9203	Twin wheel hanger-offset A		
Hanger A	9400	Micro cam hanger-offset A		
Hanger B	9401	Micro cam hanger-offset B		
			<b>Hanger mount selection example:</b>	
			Door thickness: 1-1/8"      Door weight: 60 lbs	
			<b>Select single, twin or micro cam hanger</b>	
			Front hanger: 9400      Rear hanger: 9400	

\* For use with doors 60 -75 lbs., sold separately



## BY-PASS - 9514 & 9583 PACKAGED SET COMPONENTS



### 9810

#### Aluminum Track

Materials: Extruded aluminum  
 Gauge: 0.050" (1.3 mm) thick  
 Track: 1" x 2" (25 mm x 51 mm)  
 Lengths: 48" (1219 mm) to 144" (3658 mm)

Notes:

- For doors up to 75 lbs (34 kg)
- One piece track



### 9353

#### Adjustable Door Guide

Materials: High density polyethylene  
 Notes:

- Adjustable guide from 3/4" (19 mm) to 1-3/8" (35 mm)
- Included with 9841 parts bag



### 9814

#### Parts Bag

Includes two (2) 9400 hangers, two (2) 9401 hangers, two (2) 2610-US3 pulls, and one (1) 9353 guide



### 9841

#### Optional Parts Bag

• Includes four (4) 9401 hangers, two (2) 9865 pulls, one (1) 9351 guide  
 • For use with 1" - 1-1/8" thick doors



### 9400\* | 9401\*\*

#### Micro Adjust Hanger

Materials: Zinc plated steel with molded Celcon wheels  
 Gauge: 0.075" (2 mm)  
 Wheel: 7/8" (22 mm) diameter  
 Notes:

- Side mounted with precise cam adjustment
- For use on doors weighting up to 60 lbs (27 kg)
- For use with 9810, 9820, and 9840 track
- Hanger is stamped "A" or "B" for easy identification

\* 9400 is A offset of 3/8" (9.5 mm)  
 \*\* 9401 is B offset of 11/16" (17.5 mm)



### 9865

#### Flush Cup Pull

Overall Diameter: 1-31/32" (50 mm)  
 Finger Pull Diameter: 1-19/32" (41 mm)  
 Depth: 11/32" (9 mm)  
 Projection: 5/64" (2 mm)  
 Materials: Tan color ABS plastic

Notes:

- Built-in prong design eliminates the need for screws or brads



### 9351

#### Guide

Materials: High density polyethylene  
 Guide: 4-9/16" x 1" x 11-3/16" (116 mm x 25 mm x 46 mm)

Notes:

- One piece fixed guide for 1-3/8" (35 mm) doors
- Included with 9841 parts bag



### 2610

#### Flush Cup Finger Pull

Overall Diameter: 31/32" (25 mm)  
 Finger Pull Diameter: 3/4" (19 mm)  
 Depth: 5/16" (8 mm)  
 Projection: 1/32" (.8 mm)  
 Materials: Solid brass  
 Finishes: US3, US4, US5, US10A, US15, US15A, US26, US26D, ABA

Notes:

- Built-in prong design eliminates the need for screws or brads

### Optional Components

9200   9201	Hanger
9202   9203	Hanger
2630	Pull
9909	Adjustable Guide
9354	3/4" Riser
9815	Bumper Stop
9880	Door Stop

For optional components see pages 59-63



## BY-PASS - 9614 & 9683 PACKAGED SETS

### FEATURES

- Aluminum track with 1-3/4" (44 mm) fascia and hardware
- Conforms to ANSI A156.14
- Type: D8742

### SPECIFICATIONS

- For doors up to 1-3/8" (35 mm) thick
- Up to 60 lbs (27 kg) per door with single wheel 9201 or 9401 hangers
- Up to 75 lbs (34 kg) per door with twin wheel 9202 hangers
- Track is extruded aluminum jump-proof style with integral 1-3/4" (44 mm) fascia
- Hangers have one or two side mounted 7/8" (22 mm) diameter wheels
- Uses all B offset hangers
- Grooved fascia, ideal for painting

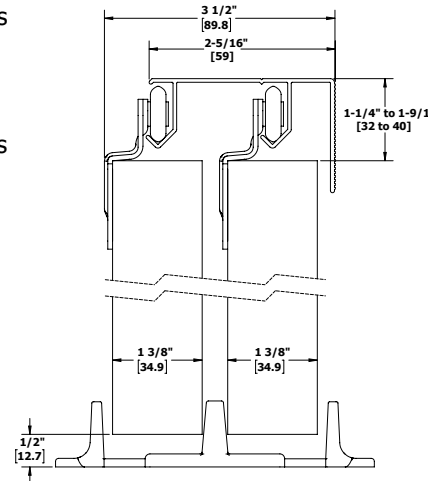
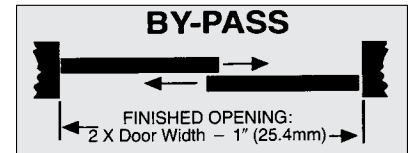

*Interchanges with Stanley 8139 track, BP75-06, 8400 Series sets, 40-3340 and Cox 12-400 Series.*

Part Number	Description
9614 Packaged Set (for two doors)	Includes one (1) 9820 track and one (1) 9540 parts bag: (4) 9401 hangers, two (2) 2610-US3 pulls, one (1) 9351 floor guide
9614-48	By-Pass Set - For two 24" (610 mm) door hangers, two (2) 2610 - US3
9614-60	By-Pass Set - For two 30" (762 mm) door pulls, one (1) 9351 floor guide
9614-72	By-Pass Set - For two 36" (914 mm) doors
9683 Series Set (for three doors)	Includes one (1) 9820 track and six (6) 9401 hangers, two (2) 9351 guides, and three (3) 2610 pulls
9683-96	By-Pass Set - For three 32" (813 mm) doors

Use the chart below to select the correct hanger offset combination for your application.

Side Mount Selection Chart				
Door Thickness	3/4" (19 mm)	1" (25.4 mm)	1-1/8" (29 mm)	1-3/8" (35 mm)
Front Hanger	B	B	A or B	A
Rear Hanger	A	A	Same as front	B
Door Gap	3/4"	1/2"	11/16"	9/16"
	<b>Item #</b>	<b>Description</b>	<b>Notes:</b>	
Hanger A	9200	Single wheel hanger-offset A	Hanger is stamped "A" or "B" for easy identification	
Hanger B	9201	Single wheel hanger-offset B	For consideration for 9514, 9583, 9614, 9683, 9844 and 9845 By-Pass packaged sets.	
Hanger B	9202	Twin wheel hanger-offset B	<b>Hanger mount selection example:</b>	
Hanger A	9203	Twin wheel hanger-offset A	Door thickness: 1-1/8"                      Door weight: 60 lbs	
Hanger A	9400	Micro cam hanger-offset A	<b>Select single, twin or micro cam hanger</b>	
Hanger B	9401	Micro cam hanger-offset B	Front hanger: 9400                      Rear hanger: 9400	



## BY-PASS - 9614 & 9683 TRACK COMPONENTS



### 9820 Aluminum Track with 1-3/4\" data-bbox="214 159 433 204"/>

Materials: Extruded aluminum  
 Gauge: 0.050" (1.3 mm)  
 Track: 1-3/4" x 3" (44 mm x 76 mm)  
 Lengths: 48" (1219 mm) to 144" (3658 mm)

- Notes:
- For doors up to 75 lbs (34 kg)
  - For use on doors up to 1-3/8" (35 mm)
  - For use with 7/8" (22 mm) diameter hanger wheels
  - One piece track with built-in grooved fascia



### 9351 Guide

Materials: High density polyethylene  
 Guide: 4-9/16" x 1" x 11-3/16" (116 mm x 25 mm x 46 mm)  
 Notes: One piece fixed guide for 1-3/8" (35 mm) doors

### Optional Part Bags



### 9544 Parts Bag

Includes four (4) 9202 hangers, two (2) 2630-US3 pulls, and one (1) 9351 guide



### 9540 Parts Bag

Includes four (4) 9401 hangers, two (2) 2610-US3 pulls, and one (1) 9351 guide



### 9841 Parts Bag

Includes four (4) 9401 hangers, two (2) 9865 pulls, and one (1) 9351 guide



### 9401 "B" Offset Hanger Micro Adjust Hanger

Materials: Zinc plated steel with molded Celcon wheels  
 Gauge: 0.075" (2 mm)  
 Wheel: 7/8" (22 mm) diameter  
 Notes:

- Side mounted with precise cam adjustment
- For use on doors weighting up to 60 lbs (27 kg)
- For use with 9810, 9820, and 9840 track



### 9842 Parts Bag

Includes four (4) 9401 hangers, two (2) 2630-US3 pulls, and one (1) 9351 guide



### 9843 Parts Bag

Includes four (4) 9202 hangers, two (2) 9865 pulls, and one (1) 9351 guide



### 2610 Flush Cup Finger Pull

Overall Diameter: 31/32" (25 mm)  
 Finger Pull Diameter: 3/4" (19 mm)  
 Depth: 5/16" (8 mm)  
 Projection: 1/32" (.8 mm)  
 Materials: Solid brass  
 Finishes: US3  
 Notes: Built-in prong design eliminates the need for screws or brads

### Optional Components

9200   9201	Hanger
9202   9203	Hanger
2630	Pull
9865	Pull
9909	Adjustable Guide
9353	Adjustable Guide
9354	3/4" Riser
9815	Bumper Stop
9880	Door Stop

For optional components see pages 59-63



## BY-PASS - 9673 & 9674 PACKAGED SETS

### FEATURES

- Heavy duty aluminum track with 2-5/8" (66 mm) Built-In Grooved Fascia and Hardware
- Conforms to ANSI A156.14
- Type: D8751, D8752

### SPECIFICATIONS

- For doors 1-3/8" - 1-3/4" (35 mm - 44 mm) thick
- 9673 packaged sets for up to 125 lbs (57 kg) per door
- 9674 packaged sets for up to 150 lbs (68 kg) per door
- Track is extruded aluminum jump-proof style with "V" shaped rails and integral 2-5/8" (66 mm) fascia
- Hangers have four (4) 7/8" (22 mm) diameter wheels
- Integral 2-5/8" grooved fascia
- Grooved fascia, ideal for painting

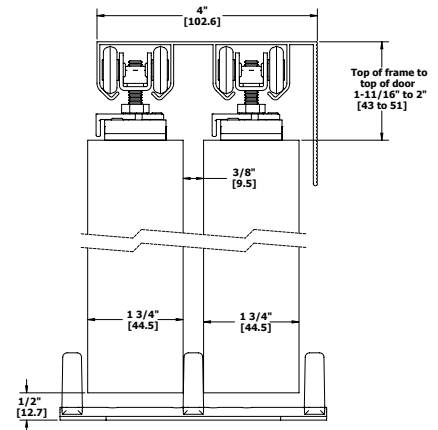
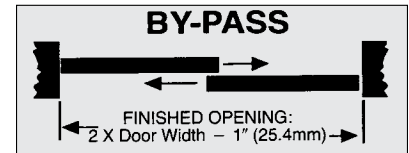

*Interchanges with Stanley S1700F Series/BP150F; Johnson 134F/138F; and Lawrence F581 track, HDF520 Series sets.*

Part Number	Description
<b>9673 Packaged Set</b> Includes one (1) 9603 track and one (1) 9679 parts bag: four (4) 9605 hangers, four (4) 9610 plates, and one (1) 9909 guide For doors up to 125 lbs (57 kg)	
9673-48	By-Pass Set - For two 24" (610 mm) doors
9673-60	By-Pass Set - For two 30" (762 mm) doors
9673-72	By-Pass Set - For two 36" (914 mm) doors
9673-96	By-Pass Set - For two 48" (1219 mm) doors
<b>9674 Series Set</b> Includes one (1) 9603 Packaged Set track and one (1) 9680 parts bag: four (4) 9606 hangers, four (4) 9610 plates, and one (1) 9909 guide For doors up to 150 lbs (68 kg)	
9674-48	By-Pass Set - For two 24" (610 mm) door
9674-60	By-Pass Set - For two 30" (762 mm) door
9674-72	By-Pass Set - For two 36" (914 mm) door
9674-96	By-Pass Set - For two 48" (1219 mm) door



## BY-PASS - 9673 & 9674 TRACK COMPONENTS



### 9603

#### Heavy Duty Aluminum Double Box Track

Materials: Extruded aluminum  
 Gauge: 0.050" (1.3 mm)  
 Track: 1-1/16" x 4" (27 mm x 102 mm)  
 Lengths: 48" (1219 mm) to 144" (3658 mm)

- Notes:
- Grooved fascia for painting
  - Jump proof double twin channel design
  - One piece track with built-in grooved fascia



### 9909

#### Adjustable Guide

Materials: Steel with bright zinc finish  
 Posts: Molded Celcon/Nylon  
 Gauge: 0.060" (1.5 mm)  
 Guide: 4-7/8" x 1-5/8" x 1-3/16" (124 mm x 41 mm x 30 mm)  
 Notes: For doors 3/4" to 1-3/4" (19 mm to 44 mm) thick and up to 275 lbs (125 kg)



### 9679

#### Parts Bag

For 125 lbs (57 kg) per door - Includes four (4) 9605 hangers with quick release top mount plate, four (4) 9610 plates, and one (1) 9909 guide



### 9680

#### Parts Bag

For 150 lbs (68 kg) doors - Includes four (4) 9606 ball bearing hangers, four (4) 9610 plates, and one (1) 9909 guide  
 Note: Up to 125 lbs (57 kg) per door



### 9605

#### 4-Wheel Hanger

For 125 lbs (57 kg) doors  
 Materials: Steel with brass-tone dichromate finish  
 Wheel: 7/8" (22 mm) diameter  
 Notes:

- Wheels are self aligning to allow consistent contact with track
- Pre-lubricated Celcon wheels
- Up to 125 lbs (57 kg) per door
- Use in conjunction with 9601, 9602 or 9603 track



### 9606

#### 4-Wheel Ball Bearing Hanger

For 150 lbs (68 kg) doors  
 Materials: Steel with brass-tone dichromate finish  
 Wheel: 7/8" (22 mm) diameter  
 Notes:

- Wheels are self aligning to allow consistent contact with track
- Pre-lubricated Celcon wheels mounted on steel ball bearing shafts
- For doors up to 150 lbs (68 kg)
- Used in conjunction with 9607, 9608 or 9610 top door plate and 9599, 9601 or 9602 track



### 9610

#### Replacement Top Mount Plate

Materials: Bright zinc plated steel  
 Gauge: 1/8" (3 mm)  
 Size: 1-3/8" (35 mm) x 2-13/16" (72 mm)  
 Notes: Replacement for four wheel hangers 9605, 9606, 9575, 9824, 9825 and 9827

### Optional Components

2610	Pull
2630	Pull
9865	Pull
9610	Top Mount Plate
9351	Adjustable Guide
9353	Adjustable Guide
9354	3/4" Riser
9815	Bumper Stop
9880	Door Stop

For optional components see pages 59-63

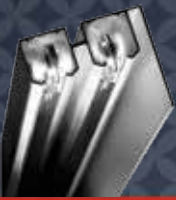

## BY-PASS - 9675 & 9676 PACKAGED SETS

### FEATURES

- Heavy duty aluminum double box track and hardware
- Conforms to ANSI A156.14
- Type: D8731, D8741, D8751

### SPECIFICATIONS

- For doors 1-3/8" - 1-3/4" (35 mm - 44 mm) thick
- Up to 100 lbs (45 kg) with 9572 hangers
- 9675 packaged sets for up to 125 lbs (57 kg) per door
- 9676 packaged sets for up to 150 lbs (68 kg) per door
- Track is extruded aluminum jump-proof style with "V" shaped rails
- Hangers have four (4) 7/8" (22 mm) diameter wheels

Part Number	Description
<b>9675 Packaged Set</b> Includes one (1) 9602 track and one (1) 9679 parts bag: four (4) 9605 hangers, four (4) 9609 plates, and one (1) 9909 guide For doors up to 125 lbs (57 kg) per door	
9675-48	By-Pass Set - For two 24" (610 mm) doors
9675-60	By-Pass Set - For two 30" (762 mm) doors
9675-72	By-Pass Set - For two 36" (914 mm) doors
9675-96	By-Pass Set - For two 48" (1219 mm) doors
<b>9676 Packaged Set</b> Includes one (1) 9602 track and one (1) 9680 parts bag: four (4) 9606 hangers, four (4) 9609 plates, and one (1) 9909 guide For doors up to 150 lbs (68 kg) per door	
9676-48	By-Pass Set - For two 24" (610 mm) door
9676-60	By-Pass Set - For two 30" (762 mm) door
9676-72	By-Pass Set - For two 36" (914 mm) door
9676-96	By-Pass Set - For two 48" (1219 mm) door

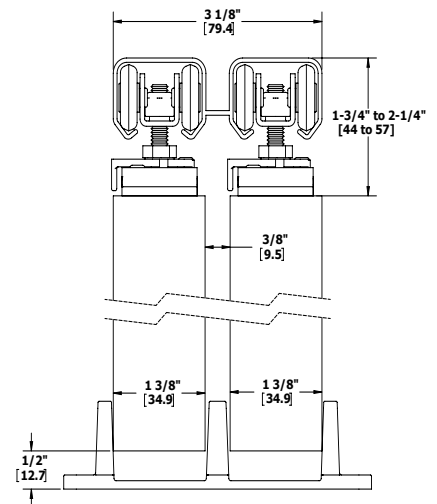
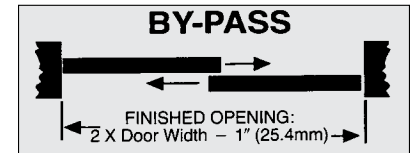

*Interchanges with Stanley 1755, 40-3664, 40-3855/BP150; Johnson 134F/138F; Grant 7000 Series, Cox 15-220 Series; and Lawrence 581 track, HD520 hardware.*





## BY-PASS - 9675 & 9676 TRACK COMPONENTS



### 9602 Heavy Duty Aluminum Double Box Track

Materials: Extruded aluminum  
 Gauge: 0.050" (1.3 mm) thick  
 Track: 1-1/16" x 3-1/8"  
 (27 mm x 79 mm)  
 Lengths: 46" (1168 mm) to 142"  
 (3607 mm)  
 Notes: Jump proof double twin  
 channel design



### 9909 Adjustable Guide

Materials: Steel with bright zinc finish  
 Posts: Molded Celcon/Nylon  
 Gauge: 0.060" (1.5 mm)  
 Guide: 4-7/8" x 1-5/8" x 1-3/16"  
 (124 mm x 41 mm x 30 mm)  
 Notes: For doors 3/4" to 1-3/4"  
 (19 mm to 44 mm) thick and  
 up to 275 lbs (125 kg)



### 9679 Parts Bag

Includes four (4) 9605 hangers with quick  
 release top mount plate, and one (1)  
 9909 guide  
 Note: Up to 125 lbs (57 kg) per door



### 9680 Parts Bag

For 150 lbs (68 kg) doors - Includes four  
 (4) 9606 ball bearing hangers, four (4)  
 9610 plates, and one (1) 9909 guide  
 Note: Up to 125 lbs (57 kg) per door



### 9605 4-Wheel Hanger

For 125 lbs (57 kg) doors  
 Materials: Steel with brass-tone  
 dichromate finish  
 Wheel: 7/8" (22 mm) diameter  
 Notes:
 

- Wheels are self aligning to  
 allow consistent contact  
 with track
- Pre-lubricated Celcon wheels
- Up to 125 lbs (57 kg) per door
- Use in conjunction with  
 9601, 9602 or 9603 track



### 9606 4-Wheel Ball Bearing Hanger

For 150 lbs (68 kg) doors  
 Materials: Steel with brass-tone  
 dichromate finish  
 Wheel: 7/8" (22 mm) diameter  
 Notes:
 

- Wheels are self aligning to  
 allow consistent contact  
 with track
- Pre-lubricated Celcon  
 wheels mounted on steel  
 ball bearing shafts
- For doors up to 150 lbs (68 kg)
- Used in conjunction with  
 9607, 9608 or 9610 top  
 door plate and 9599, 9601  
 or 9602 track



### 9610 Replacement Top Mount Plate

Materials: Bright zinc plated steel  
 Gauge: 1/8" (3 mm)  
 Size: 1-3/8" (35 mm) x 2-13/16"  
 (72 mm)  
 Notes: Replacement for four  
 wheel hangers 9605, 9606,  
 9575, 9824, 9825 and 9827

### Optional Components

9709	Fascia
2610	Pull
2630	Pull
9865	Pull
9610	Top Mount Plate
9351	Adjustable Guide
9353	Adjustable Guide
9354	3/4" Riser
9815	Bumper Stop
9880	Door Stop

For optional components see pages 59-63

## BY-PASS - 9110 & 9130 PACKAGED SETS

### FEATURES

- Heavy duty aluminum I-beam track and hardware
- Conforms to ANSI A156.14/Type: D8731

### SPECIFICATIONS

- For doors 1" - 1-3/4" (25 mm - 45 mm) thick
- 9110 Series for doors weighing up to 175 lbs (79.5 kg) per door
- 9130 Series for doors weighing up to 275 lbs (124.7 kg) per door
- Track is extruded aluminum jump-proof style with "I" shaped rails
- Hangers have 1" (25 mm) diameter wheels with steel ball bearings
- Order two sets per opening per by pass

Part Number	Description
<b>9110 Series Set</b> Includes one (1) 9101 track and one (1) 9109 parts bag: two (2) 9102 hangers, and one (1) 9115 floor guide For doors up to 175 lbs (79.5 kg) per door	
9110-60	5' (1524 mm) By-Pass Set - For one 2'6" (762 mm) door
9110-72	6' (1839 mm) By-Pass Set - For one 3'0" (914 mm) door
9110-84	7' (2134 mm) By-Pass Set - For one 3'6" (1067 mm) door
9110-96	8' (2438 mm) By-Pass Set - For one 4'0" (1219 mm) door
9110-120	10' (3048 mm) By-Pass Set - For one 5'0" (1529 mm) door
9110-144	12' (3658 mm) By-Pass Set - For one 6'0" (1829 mm) door
<b>9130 Series Set</b> Includes one (1) 9101 track and one (1) 9129 parts bag: two (2) 9105 hangers, and one (1) 9115 floor guide For doors up to 275 lbs (125 kg)	
9130-60	5' (1524 mm) By-Pass Set - For one 2'6" (762 mm) door
9130-72	6' (1839 mm) By-Pass Set - For one 3'0" (914 mm) door
9130-84	7' (2134 mm) By-Pass Set - For one 3'6" (1067 mm) door
9130-96	8' (2438 mm) By-Pass Set - For one 4'0" (1219 mm) door
9130-120	10' (3048 mm) By-Pass Set - For one 5'0" (1529 mm) door
9130-132	11' (3353 mm) By-Pass Set - For one 5'6" (1676 mm) door
9130-144	12' (3658 mm) By-Pass Set - For one 6'0" (1829 mm) door

**TRACKS** - Two sets required for by-pass opening - 0.125" (3 mm) thick aluminum

Part Number	Description
Tracks for use with 9110 Series and 9130 Series	
9101-72	72" (1829 mm) Aluminum I-Beam Track
9101-84	84" (2134 mm) Aluminum I-Beam Track
9101-96	96" (2438 mm) Aluminum I-Beam Track
9101-120	120" (3048 mm) Aluminum I-Beam Track
9101-144	144" (3658 mm) Aluminum I-Beam Track
9101-192	192" (4877 mm) Aluminum I-Beam Track

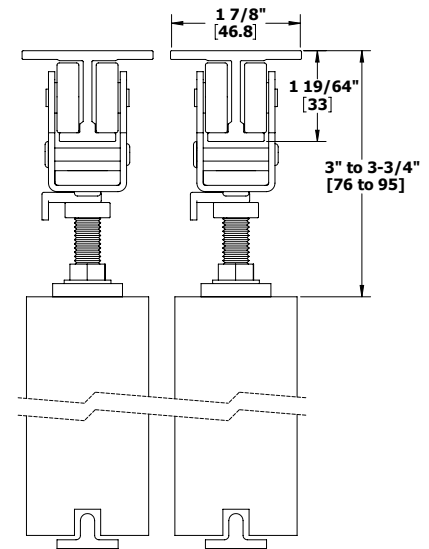
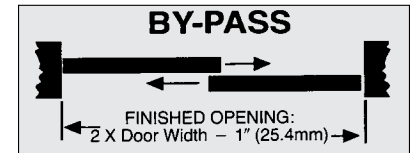

*Interchanges with Grant 1210/1230 Series*

Optional Bottom Track  
9121 - 9122

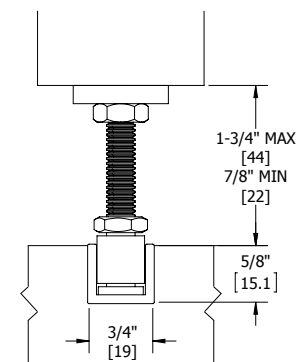

Installation note: Clearance between door bottom and top of 9122 track must be 7/8" (22 mm) minimum to 1-3/4" (44 mm) maximum.



## BY-PASS - 9110 & 9130 TRACK COMPONENTS



### 9101

#### I Beam Track

Materials: Extruded aluminum  
 Gauge: 0.125" (3 mm)  
 Lengths: 72" (1829 mm) to 192" (4877 mm)

Notes: Mounting holes are prepunched for ease of installation



### 9129

#### Parts Bag

Includes two (2) 9105 4-wheel hangers and one (1) 9115 floor guide



### 9109

#### Parts Bag

Includes two (2) 9102 2-wheel hangers and one (1) 9115 floor guide



### 9105

#### 4 Wheel Hanger

Materials: Zinc plated steel  
 Wheels: Nylon with steel ball bearings  
 Hanger: 4" x 2" x 1-3/4" (102 mm x 51 x 45 mm)  
 Bolt: 3/8" x 2-5/16" (10 mm x 59 mm)  
 Top Plate: 1" x 3-1/2" x 3/16" (25.4 mm x 89 mm x 5 mm)  
 Notes:
 

- Use with 9101 track, with doors weighing up to 275 lbs (125 kg)
- Four wheel hanger is self-aligning to allow consistent contact with track



### 9102

#### 2 Wheel Hanger

Materials: Zinc plated steel  
 Wheels: Nylon with steel ball bearings  
 Hanger: 1-13/16" x 2" x 1-1/8" (46 mm x 51 mm x 29 mm)  
 Bolt: 3/8" x 2-5/16" (10 mm x 59 mm) (Bolt not same as 9105)  
 Top Plate: 1" x 3-1/2" x 3/16" (25 mm x 89 mm x 5 mm)  
 Notes: Use with 9101 track, with doors weighing up to 175 lbs (79 kg)



### 9115

#### Bottom Door Guide

Materials: Die cast zinc aluminum alloy  
 Guide: 7/8" x 3/4" x 3" (22 mm x 19 mm x 76 mm)  
 Notes: Door bottom prep requires 1/4" (6 mm) wide kerf and 9/16" (14 mm) depth

### Optional Components

9111	Fixed Bottom Door Guide
9113	Door Stop
9114	Bottom Guide Rail
9121	Bottom Door Guide
9122	Bottom Guide Channel
9909	Adjustable Guide

For optional components see pages 59-63



## BY-PASS - 9611 & 9612 PACKAGED SETS

### FEATURES

- Heavy duty aluminum box double track and hardware
- Conforms to ANSI A156.14
- Type: D8731, D8751

### SPECIFICATIONS

- For doors 1-3/8" (35 mm) thick doors (top figure) - no spacer kit required
- For doors 1-3/4" (45 mm) thick with tracks spaced 3/8" (10 mm) apart using 9573 (bottom figure)
- 9611 Packaged Sets for doors weighing up to 150 lbs (68 kg) per door
- 9612 Packaged Sets for doors weighing up to 250 lbs (113 kg) per door
- Quick release hangers allow easy door hanging and removal
- Hangers have 1" (25 mm) diameter wheels
- Universal extruded aluminum track interchanges with Stanley and Johnson hangers and track

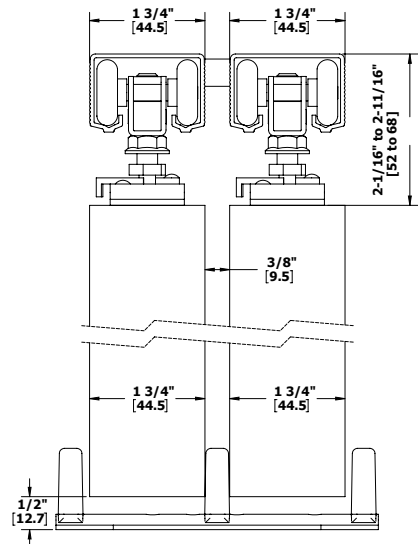
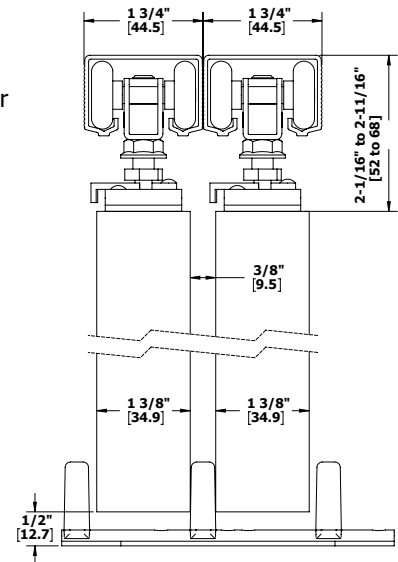
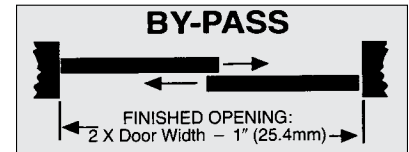

Part Number	Description
9611 Packaged Set Includes two (2) 9821 tracks and one (1) 9892 parts bag: four (4) 9824 hangers, one (1) 9909 guide, and one (1) 9573 spacer For doors up to 150 lbs (68 kg) per door	
9611-60	By-Pass Set - For two 30" (762 mm) doors
9611-72	By-Pass Set - For two 36" (914 mm) doors
9611-96	By-Pass Set - For two 48" (1219 mm) doors
9612 Series Set Includes two (2) 9821 tracks and one (1) 9893 parts bag: four (4) 9825 hangers, one (1) 9909 guide, and one (1) 9573 spacer For doors up to 250 lbs (113 kg) per door	
9612-60	By-Pass Set - For two 30" (762 mm) door
9612-72	By-Pass Set - For two 36" (914 mm) door
9612-96	By-Pass Set - For two 48" (1219 mm) door

Optional Bottom Track  
9121 - 9122

Installation note: Clearance between door bottom and top of 9122 track must be 7/8" (22 mm) minimum to 1-3/4" (44 mm) maximum.

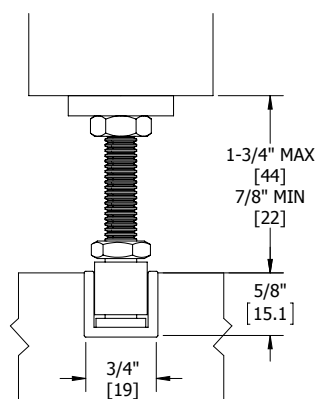

Interchanges with Stanley 125/250 Series and Johnson 100 Series





## BY-PASS - 9611 & 9612 TRACK COMPONENTS



### 9821

#### Aluminum Box Track

- Materials: Extruded aluminum  
 Gauge: 0.06" (2 mm) thick  
 Track: 1-5/8" x 1-1/16"  
 (41 mm x 27 mm)  
 Lengths: 59" (1499 mm) to 144"  
 (3658 mm)  
 Notes:
  - Jump proof twin channel design
  - Two-piece required for by-pass



### 9573

#### Celcon Plastic Spacer Kit

- Materials: Celcon plastic  
 Notes:
  - Includes screws
  - Properly spaces two single tracks for 1-3/4" (44 mm) doors



### 9892

#### Parts Bag

- Includes four (4) 9824 4-wheel hangers with quick release top mount plate, one (1) 9909 guide, and one (1) 9573 spacer kit  
 Note: Up to 150 lbs (68 kg) per door



### 9893

#### Parts Bag

- Includes four (4) 9825 4-wheel ball bearing hangers with quick release top mount plate, one (1) 9909 guide, and one (1) 9573 spacer kit  
 Note: Up to 250 lbs per door



### 9824

#### 4 Wheel Hanger with Quick Release Top Mount Plate

- Materials: Zinc plated steel  
 Wheels: Self aligning to allow consistent contact with track  
 Wheel: 1" (25 mm) diameter  
 Notes:
  - Pre-lubricated Celcon wheels
  - Up to 150 lbs (68kg) per door
  - For use with 9821 track
  - Quick release feature allows easy door hanging and removal



### 9825

#### 4 Wheel Ball Bearing Hanger with Quick Release Top Mount Plate

- Materials: Zinc plated steel  
 Wheels: Self aligning to allow consistent contact with track with steel ball bearings  
 Wheel: 1" (25 mm) diameter  
 Notes:
  - Pre-lubricated Celcon wheels
  - Up to 250 lbs (113 kg) per door
  - For use with 9821 track
  - Quick release feature allows easy door hanging and removal



### 9909

#### Adjustable Guide

- Materials: Steel with bright zinc finish  
 Posts: Molded Celcon/Nylon  
 Gauge: 0.060" (1.5 mm)  
 Guide: 4-7/8" x 1-5/8" x 1-3/16"  
 (124 mm x 41 mm x 30 mm)  
 Notes: For doors 3/4" to 1-3/4"  
 (19 mm to 44 mm) thick and up to 275 lbs (125 kg)

### Optional Components

9709	Fascia
2610	Pull
2630	Pull
9865	Pull
9121	Bottom Door Guide
9122	Bottom Guide Channel
9351	Adjustable Guide
9353	Adjustable Guide
9354	3/4" Riser
9815	Bumper Stop
9880	Door Stop

For optional components see pages 59-63



## BY-PASS - 9875 PACKAGED SETS

### FEATURES

- Heavy duty aluminum box double track and hardware
- Conforms to ANSI A156.14
- Type: D8731, D8751

### SPECIFICATIONS

- For doors 1-3/8" - 1-3/4" (35 mm - 44 mm) thick (top figure)
- For doors 1-3/4" (44 mm) thick, tracks are spaced 3/8" (10 mm) apart using 9574 (bottom figure)
- Up to 250 lbs (113 kg) per panel
- Track is extruded aluminum jump-proof style with "V" shaped rails
- Hangers have four (4) 1-1/4" (32 mm) diameter wheels

Part Number	Description
9875 Series Set - Packaged set for doors up to 1-3/4" (44 mm) thick Includes two (2) 9801 tracks, four (4) 9827 hangers, one (1) 9574 spacer, and one (1) 9909 guide	
9875-48	By-Pass Set - 4' (1219 mm) opening for two doors
9875-60	By-Pass Set - 5' (1524 mm) opening for two doors
9875-72	By-Pass Set - 6' (1829) opening for two doors
9875-96	By-Pass Set - 8' (2438 mm) opening for two doors

### TRACKS - 0.075" (1.9 mm) thick aluminum

Part Number	Description
Tracks for use with 9875 Series	
9801-72	72" (1829 mm) Aluminum Box Track
9801-96	96" (2438 mm) Aluminum Box Track
9801-120	120" (3048 mm) Aluminum Box Track
9801-144	144" (3658 mm) Aluminum Box Track
9801-192	192" (4877 mm) Aluminum Box Track

### FASCIA - 2-3/4" (70 mm) high with 5/8" (16 mm) lip

Part Number	Description
9809-72	72" (1829 mm) 3-7/8" (98 mm) Aluminum Fascia
9809-96	96" (2438 mm) 3-7/8" (98 mm) Aluminum Fascia

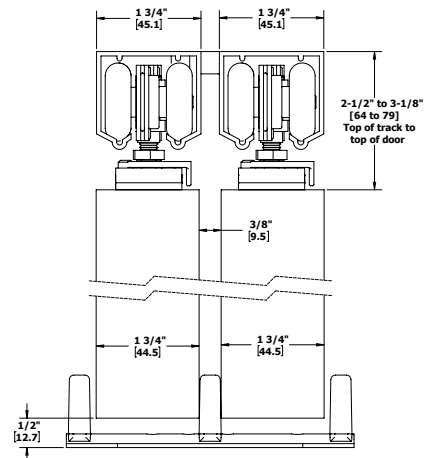
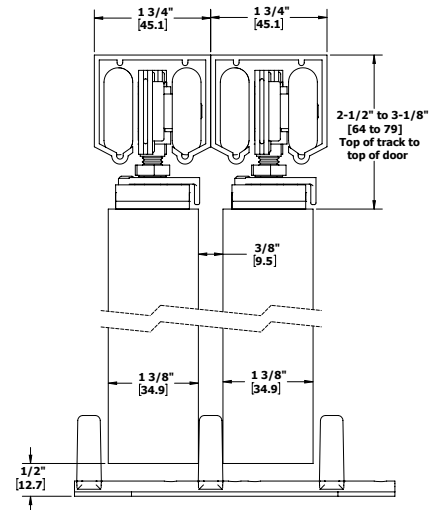
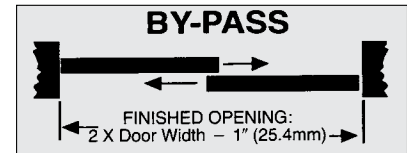

Interchanges with Stanley 57/58.





## BY-PASS - 9875 TRACK COMPONENTS



### 9801

#### Heavy Duty Aluminum Box Track

- Material: Extruded aluminum  
 Gauge: 0.075" (1.9 mm)  
 Track: 1-5/8" x 1-3/4"  
 (41 mm x 44 mm)  
 Lengths: 72" (1829 mm) to 192"  
 (4877 mm)  
 Notes:
  - For doors up to 250 lbs (113 kg)
  - Jump proof twin channel design



### 9909

#### Adjustable Guide

- Materials: Steel with bright zinc  
 Posts: Molded Celcon/Nylon  
 Gauge: 0.060" (1.5 mm)  
 Guide: 4-7/8" x 1-5/8" x 1-3/16"  
 (124 mm x 41 mm x 30 mm)  
 Notes: For doors 3/4" to 1-3/4"  
 (19 to 44 mm) thick and  
 up to 275 lbs (125 kg)



### 9809

#### Aluminum Fascia

- Materials: Extruded aluminum  
 Gauge: 0.072" (1.8 mm)  
 Lip: 1-3/4" (44 mm)  
 Fascia: 3-7/8" (98 mm)  
 Lengths: 72" (1829 mm) and  
 96" (2438 mm) lengths  
 Notes:
  - Grooved fascia for painting
  - Pre-punched holes for easy installation



### 9574

#### Track Spacer Kit

- Materials: Celcon plastic  
 Notes:
  - Includes screws
  - Properly spaces two single tracks for 1-3/4" (44 mm) doors
  - For use with 9801 track



### 9827

#### Four Wheel Ball Bearing Hanger

- Materials: Zinc plated steel  
 Wheels: Self aligning to allow  
 consistent contact with track  
 Wheel: 1-1/4" (32 mm) diameter  
 Notes:
  - For doors up to 250 lbs (113 kg)
  - Pre-lubricated Celcon wheels on steel shafts with steel ball bearings
  - Ball bearing axles
  - For use with 9801 Track

### Optional Components

- |      |                             |
|------|-----------------------------|
| 330D | Pocket Door Latch           |
| 330L | Pocket Door Privacy Latch   |
| 330M | Pocket Door Privacy Latch   |
| 2630 | Flush Cup Pull              |
| 9881 | Bumper                      |
| 9883 | Two Piece Pocket Door Guide |
| 9884 | Pocket Door Edge Pull       |
| 9815 | Bumper Stop                 |
| 9884 | Pocket Edge Pull            |
| 9889 | Non-Adjustable Floor Guide  |

For optional components see pages 59-63

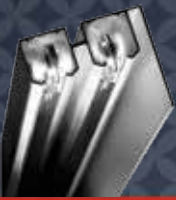

## BY-PASS - 9885 & 9886 PACKAGED SETS

### FEATURES

- Heavy duty aluminum double box track with 3-1/2" (89 mm) smooth fascia and hardware
- Conforms to ANSI A156.14
- Type: D8731, D8751

### SPECIFICATIONS

- For doors 1-3/8" - 1-3/4" (35 mm - 44 mm) thick
- Up to 250 lbs (113 kg) per door
- Track is extruded aluminum jump-proof style with "V" shaped rails and integral 3-1/2" (88 mm) fascia
- Integral 3-1/2" (88 mm) smooth fascia
- Smooth fascia mount to be accompanied by decorative trim
- Hangers have four (4) 1-1/4" (32 mm) diameter wheels
- Smooth finish fascia

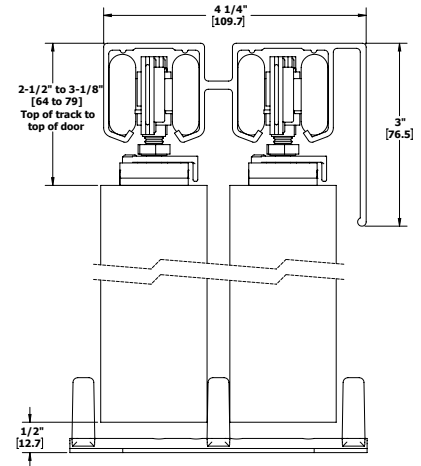
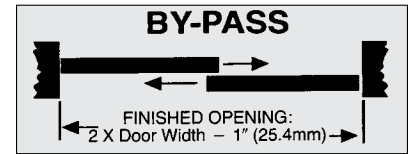

Part Number	Description
9885 Packaged Set for two doors up to 250 lbs. (117 kg.) each Includes one (1) 9803 track, four (4) 9827 hangers, one (1) 9909 guide, and one (1) 9880 bumper stop	
9885-48	By-Pass Set - 4' (1219 mm) opening for two doors
9885-60	By-Pass Set - 5' (1524 mm) opening for two doors
9885-72	By-Pass Set - 6' (1829 mm) opening for two doors
9885-96	By-Pass Set - 8' (2438 mm) opening for two doors
9886 Packaged Set for four doors up to 250 lbs. (113 kg.) each Includes eight (8) 9827 hangers, and one (1) 9880 door stop, and two (2) 9909 guide	
9886-96	By-Pass Set - 8' (2438 mm) opening for four doors

### TRACKS - 0.06" (1.5 mm) thick aluminum

Part Number	Description
Tracks for use with 9800 Series	
9821-59	59" (1499 mm) Heavy Duty Aluminum Box Track
9821-71	71" (1803 mm) Heavy Duty Aluminum Box Track
9821-96	96" (2438 mm) Heavy Duty Aluminum Box Track
9821-144	144" (3658 mm) Heavy Duty Aluminum Box Track







## BY-PASS - 9885 & 9886 TRACK COMPONENTS



### 9803 Heavy Duty Aluminum Double Box Track with 3-1/2" (89 mm) Smooth Fascia

Materials: Extruded aluminum  
Gauge: 0.075" (1.9 mm) thick  
Track: 3-1/2" x 4-1/2"  
(89 mm x 114 mm)  
Lengths: 48" (1219 mm) to 144"  
(3658 mm)

- Notes:
- Up to 250 lbs (113 kg) per door
  - Jump proof twin channel design
  - One piece track with built-in smooth fascia
  - Smooth fascia meant to be accompanied by decorative trim
  - Hager does not offer decorative trim



### 9909 Adjustable Guide

Materials: Steel with bright zinc  
Posts: Molded Celcon/Nylon  
Gauge: 0.060" (1.5 mm)  
Guide: 4-7/8" x 1-5/8" x 1-3/16"  
(124 mm x 41 mm x 30 mm)  
Notes: For doors 3/4" to 1-3/4"  
(19 mm to 44 mm) thick and  
up to 275 lbs (125 kg)



### 9827 Four Wheel Ball Bearing Hanger

Materials: Zinc plated steel  
Wheels: Self aligning to allow  
consistent contact with track  
Wheel: 1-1/4" (32 mm) diameter  
Notes:

- For doors up to 250 lbs (113 kg)
- Pre-lubricated Celcon wheels on steel shafts with steel ball bearings
- Ball bearing axles
- For use with 9801 track



### 9880 Door Stop

Materials: Zinc plated steel and rubber  
Gauge: 0.090" (2.3 mm)  
Stop: 1-1/4" x 1-1/4" x 7/8"  
(32 mm x 32 mm x 22 mm)  
Notes:

- For doors up to 175 lbs (79 kg)
- Keeps rear door pull exposed
- Mounts on door
- Not included in sets

### Optional Components

2610	Pull
2630	Pull
9865	Pull
9351	Adjustable Guide
9353	Adjustable Guide
9354	3/4" Riser
9815	Bumper Stop
9880	Door Stop
9268	By-Pass Door Keyed Lock
9900	Rev. Side Mount Bracket

For optional components see pages 59-63



# Bi-Fold



Hager Companies Bi-Fold (by-fold) door hardware is, the smoother the operation of your doors will be—over the lifetime of the installation. Contractors, specification writers and architects insist on Hager's hardware sets and components to ensure trouble-free installation and reliable performance.

Hager offers a wide range of classic Bi-Fold door hardware sets featuring heavy-duty aluminum tracks in 2- and 4-door configurations. Our tracks accommodate rough openings from three to eight feet and support doors up to 125 lbs.



## BI-FOLD - 9570 TRACK

### FEATURES

- Standard duty aluminum box track and hardware
- Conforms to ANSI A156.14
- Type: D8621, D8642, D8652, D8662

### SPECIFICATIONS

- For doors 1-1/8" (28.6 mm - 44 mm) to 1-3/4" (44 mm) thick
- Up to 50 lbs (57 kg) per panel bi-fold
- Up to 30 lbs (34 kg) per panel multi-fold
- Track is extruded aluminum jump-proof style with "V" shaped rails
- Hangers have four 7/8" (22 mm) diameter wheels
- Top and bottom pivots are heavy duty with solid brass bottom socket assembly for smooth, long lasting operation
- Note: Loose pin full mortise hinges 1741/1279 are recommended – not included (3 required for 9162, 6 required for 9164)

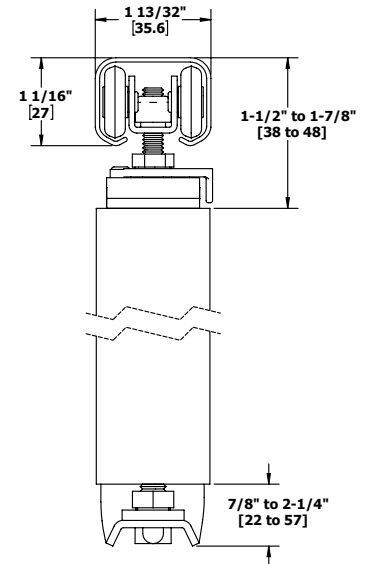
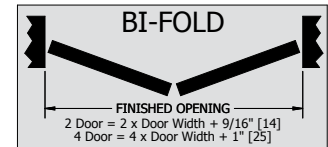

Part Number	Description
9570 Series Set - For two doors Includes one (1) 9601 track and one (1) 9571 parts bag	
9570-36	Bi-Fold Set - 3' (914 mm) opening for two 18" (457 mm) doors
9570 Series Set - For four doors Includes one (1) 9601 track and two (2) 9571 parts bag	
9570-48	Bi-Fold Set - 4' (1219 mm) opening for four 12" (305 mm) doors
9570-60	Bi-Fold Set - 5' (1524 mm) opening for four 15" (381 mm) doors
9570-72	Bi-Fold Set - 6' (1829 mm) opening for four 18" (457 mm) doors
9570-96	Bi-Fold Set - 8' (2438 mm) opening for four 24" (610 mm) doors

Optional Bottom Track  
9121 - 9122

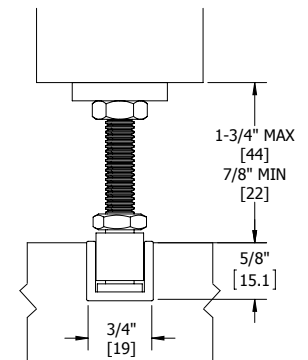

Installation note: Clearance between door bottom and top of 9122 track must be 7/8" (22 mm) minimum to 1-3/4" (44 mm) maximum.

### TRACKS - 0.050" (1.3 mm) thick aluminum

Part Number	Description
Tracks for use with 9570 Series	
9601-35	35" (889 mm) Aluminum Box Track
9601-47	47" (1194 mm) Aluminum Box Track
9601-59	59" (1499 mm) Aluminum Box Track
9601-63	63" (1600 mm) Aluminum Box Track
9601-71	71" (1803 mm) Aluminum Box Track
9601-96	96" (2438 mm) Aluminum Box Track
9601-120	120" (3048 mm) Aluminum Box Track
9601-144	144" (3658 mm) Aluminum Box Track



## BI-FOLD - 9570 TRACK COMPONENTS



### 9601

#### Aluminum Box Track

- Materials: Extruded aluminum  
 Gauge: 0.050" (1.3 mm)  
 Track: 1-1/16" x 1-3/8"  
 (27 mm x 35 mm)  
 Lengths: 35" (889 mm) to 144"  
 (2657 mm)  
 Notes:
  - Refer to series pages for weight capacities
  - Jump proof twin channel design



### 9559

#### Aligner

- Materials: Steel with brass-tone dichromate finish  
 Notes:
  - Keeps lead doors aligned when closed
  - Use one on each lead door



### 9571

#### Parts Bag

- Includes one (1) 9572 hanger, one (1) 9618 pivot set, one (1) 9559 aligner, one (1) 9558 knob, and one (1) 9815 bumper stop



### 9815

#### Bumper Stop

- Materials: Zinc plated steel and rubber  
 Notes:
  - Fits all Hager track styles except 9101
  - Screws onto track
  - Included in bi-fold sets 9570 and 9890



### 9572

#### Four Wheel Hanger with Top Mount Plate

- Materials: Steel with brass-tone dichromate finish  
 Wheel: 7/8" (22 mm) diameter  
 Notes:
  - Wheels are self aligning to allow consistent contact with track
  - Pre-lubricated Celcon wheels
  - Includes wrench
  - For use on doors weighing up to 100 lbs (45 kg) each
  - For use with 9601, 9602, and 9603 track



### Optional Part Bags

#### 9569

#### Parts Bag

- Includes one (1) 9572 hanger, one (1) 9618 pivot set, one (1) 9559 aligner, one (1) 9558 knob, one (1) 9815 bumper stop, and three (3) 9220 hinges



### 9618

#### Pivot Set

- Materials: Zinc plated steel  
 Notes:
  - For doors up to 50 lbs (23 kg)
  - Thumb wheel vertical adjustment
  - Top and bottom pivots require 3/8" (10 mm) diameter holes
  - For use with 9601



### 9220

#### Bi-Fold Door Hinge

- Materials: Steel with dichromate zinc finish  
 Hinge: 3" x 1" (76 mm x 25 mm) hole  
 Hole Locations: 1/2" (13 mm) from the center lines of holes to center of barrel  
 Notes: Non-mortise and easy to install



### 9558

#### Wood Knob

- Diameter: 1-1/2" (38 mm)  
 Materials: Solid wood  
 Notes: Will accept paint or stain

### Optional Components

- 9121 Adj. Bottom Door Guide  
 9122 Bottom Guide Channel

For optional components see pages 59-63

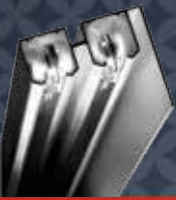

## BI-FOLD - 9860 & 9861 BI-FOLD SETS

### FEATURES

- Heavy duty aluminum box track and hardware
- Conforms to ANSI A156.14
- Type: D8621, D8641, D8651, D8661

### SPECIFICATIONS

- For doors 1-3/8" - 1-3/4" (35 mm - 44 mm) thick
- Up to 125 lbs (57 kg) per panel bi-fold
- Up to 75 lbs (34 kg) per panel multi-fold
- Quick release hangers allow easy door hanging and removal
- Universal extruded aluminum track interchanges with Stanley & Johnson track and hangers
- Hangers have 1" (25 mm) diameter wheels

Part Number	Description
9860 Bi-Fold Set - For two doors Includes one (1) 9821 track, one (1) 9894 parts bag, and three (3) 1741 3.5" x 3.5" US2D hinges	
9860-30	Bi-Fold Set - 30" (762 mm) opening for two doors
9860-36	Bi-Fold Set - 36" (914 mm) opening for two doors
9860-48	Bi-Fold Set - 48" (1219 mm) opening for two doors
9861 Bi-Fold Set - For four doors Includes one (1) 9821 track, two (2) 9894 parts bags, and six (6) 1741 3.5" x 3.5" US2D hinges	
9861-48	Bi-Fold Set - 48" (1219 mm) opening for four doors
9861-60	Bi-Fold Set - 60" (1524 mm) opening for four doors
9861-72	Bi-Fold Set - 72" (1829 mm) opening for four doors
9861-96	Bi-Fold Set - 96" (2438 mm) opening for four doors

### TRACKS - 0.06" (1.5 mm) thick aluminum

Part Number	Description
Tracks for use with 9800 Series	
9821-59	59" (1499 mm) Heavy Duty Aluminum Box Track
9821-71	71" (1803 mm) Heavy Duty Aluminum Box Track
9821-96	96" (2438 mm) Heavy Duty Aluminum Box Track
9821-144	144" (3658 mm) Heavy Duty Aluminum Box Track

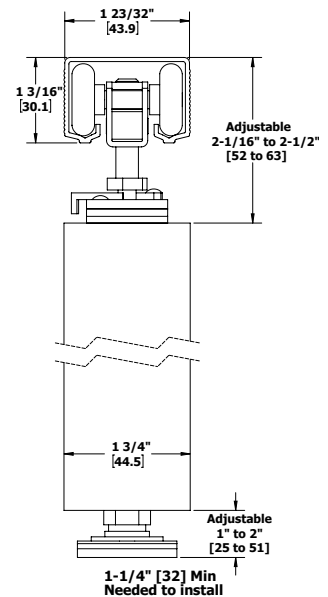
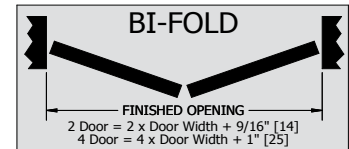

Interchanges with Stanley 125/250 Series and Johnson 100 Series.

### Optional Bottom Track 9121 - 9122

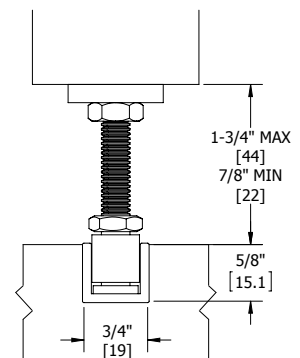

Installation note: Clearance between door bottom and top of 9122 track must be 7/8" (22 mm) minimum to 1-3/4" (44 mm) maximum.





## BI-FOLD - 9860 & 9861 TRACK COMPONENTS



### 9821

#### Aluminum Box Track

- Materials: Extruded aluminum  
 Gauge: 0.06" (1.55 mm)  
 Track: 1-5/8" x 1-1/16"  
 (41 x 27 mm)
- Lengths: 59" (1499 mm) to 144" (3658 mm)  
 Notes:
  - For doors up to 250 lbs (113 kg)
  - Jump proof twin channel design



### 9828

#### Bi-Fold Pivot Set

- Materials: Zinc plated steel  
 Notes:
  - For doors up to 125 lbs (57 kg)
  - Track pivot bearing mounts up inside track - no track cutting required
  - Bottom pivot socket has ball bearing raceway
  - Top and bottom pivots require 1/2" (13 mm) diameter and 1-3/4" (44 mm) deep holes
  - For use with 9801 and 9821 track



### 9894

#### Parts Bag

- Includes one (1) 9825 4-wheel ball bearing hanger with quick release top mount plate, one (1) 9559 aligner, one (1) 9828 bi-fold pivot set with one (1) 9815 bumper stop



### 9815

#### Bumper Stop

- Materials: Zinc plated steel and rubber  
 Notes:
  - Fits all Hager track styles except 9101
  - Screws onto track
  - Included in bi-fold sets 9570 and 9890



### 9825

#### Four Wheel Ball Bearing Quick Release Hanger

- Materials: Zinc plated steel  
 Wheels: Self aligning to allow consistent contact with track  
 Wheel: 1" (25 mm) diameter  
 Notes:
  - For doors up to 125 lbs (57 kg) for bi-fold applications
  - Pre-lubricated Celcon wheels
  - For use with 9821 track
  - Quick release feature allows easy door hanging and removal



### 9559

#### Aligner

- Materials: Steel with brass-tone dichromate finish  
 Notes:
  - Keeps lead doors aligned when closed
  - Use one on each lead door

### Optional Components

- |      |                        |
|------|------------------------|
| 1741 | Full Mortise Hinge     |
| 9220 | Bi-Fold Hinge          |
| 9121 | Adj. Bottom Door Guide |
| 9122 | Bottom Guide Channel   |
| 9558 | Wood Knob              |

For optional components see pages 59-63

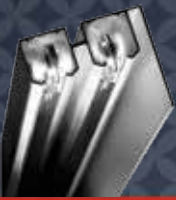

## BI-FOLD - 9890 & 9891 PACKAGED SETS

### FEATURES

- Heavy duty aluminum box track and hardware
- Conforms to ANSI A156.14
- Type: D8621, D8641, D8651, D8661

### SPECIFICATIONS

- For doors 1-1/8" - 1-3/4" (29 mm - 44 mm) thick
- Quick release hanger allows easy door hanging and removal
- Up to 125 lbs (57 kg) per panel bi-fold
- Up to 75 lbs (34 kg) per panel multi-fold
- Track is extruded aluminum jump-proof style with "V" shaped rails
- Hangers have four 1-1/4" (32 mm) diameter wheels
- Top and bottom pivots are heavy duty with ball bearing bottom socket assembly for smooth, long lasting operation
- Note: 9890 Series requires 1741 loose pin hinges – included

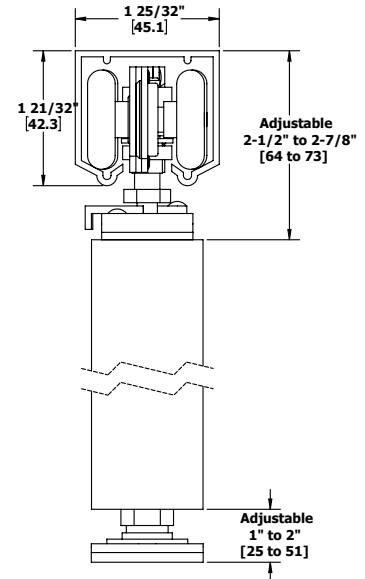
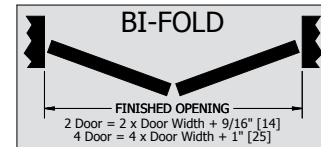

Part Number	Description
9890 Series Set - For two doors Includes one (1) 9801 track, one (1) 9827 hanger, one (1) 9828 pivot, and three (3) 1741 3.5" x 3.5" US2D hinges	
9890-30	Bi-Fold Set - 30" (762 mm) opening for two doors
9890-36	Bi-Fold Set - 36" (914 mm) opening for two doors
9890-48	Bi-Fold Set - 48" (1219 mm) opening for two doors
9891 Series Set - For four doors Includes one (1) 9801 track, one (1) 9827 hanger, one (1) 9828 pivot, and six (6) 1741 3.5" x 3.5" US2D hinges	
9891-48	Bi-Fold Set - 48" (1219 mm) opening for four doors
9891-60	Bi-Fold Set - 60" (1524 mm) opening for four doors
9891-72	Bi-Fold Set - 72" (1829 mm) opening for four doors
9891-96	Bi-Fold Set - 96" (2438 mm) opening for four doors

### TRACKS - 0.075" (1.9 mm) thick aluminum

Part Number	Description
Tracks for use with 9890 Series	
9801-72	72" (1829 mm) Aluminum Box Track
9801-96	96" (2438 mm) Aluminum Box Track
9801-120	120" (3048 mm) Aluminum Box Track
9801-144	144" (3658 mm) Aluminum Box Track
9801-192	192" (4877 mm) Aluminum Box Track

### Optional Bottom Track 9121 - 9122

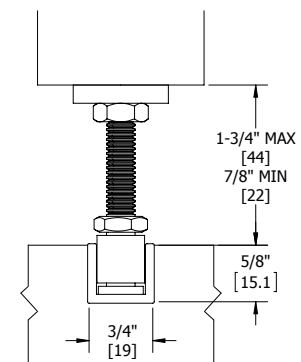

Installation note: Clearance between door bottom and top of 9122 track must be 7/8" (22 mm) minimum to 1-3/4" (44 mm) maximum.







## BI-FOLD - 9890 & 9891 TRACK COMPONENTS



### 9801

#### Heavy Duty Aluminum Box Track

- Materials: Extruded aluminum  
 Gauge: 0.075" (1.9 mm)  
 Track: 1-5/8" x 1-3/4"  
 (41 mm x 44 mm)  
 Lengths: 72" (1829 mm) to 192"  
 (4877 mm)  
 Notes:
  - For doors up to 250 lbs (113 kg)
  - Jump proof twin channel design



### 9828

#### Bi-Fold Pivot Set

- Materials: Zinc plated steel  
 Notes:
  - For doors up to 125 lbs (57 kg)
  - Track pivot bearing mounts up inside track - no track cutting required
  - Bottom pivot socket has ball bearing raceway
  - Top and bottom pivots require 1/2" (13 mm) diameter and 1-3/4" (44 mm) deep holes
  - For use with 9801 and 9821 track



### 1741

#### Full Mortise, Five Knuckle, Plain Bearing Hinge

- Steel with steel pin (ANSI A5134)
- Reversible
- Square corners
- Removable pin
- 3-1/2" x 3-1/2" (89 mm x 89 mm)
- US2D



### 9559

#### Aligner

- Materials: Steel with brass-tone dichromate finish  
 Notes:
  - Keeps lead doors aligned when closed
  - Use one on each lead door



### 9827

#### Four Wheel Ball Bearing Quick Release Hanger

- Materials: Zinc plated steel  
 Wheels: Self aligning to allow consistent contact with track  
 Wheel: 1-1/4" (32 mm) diameter  
 Notes:
  - For doors up to 125 lbs (57 kg)
  - Pre-lubricated Celcon wheels
  - Ball bearing axles
  - For doors up to 250 lbs (113 kg) for by-pass and pocket applications
  - For use with 9801 track
  - Quick release feature allows easy door hanging and removal



### 9815

#### Bumper Stop

- Materials: Zinc plated steel and rubber  
 Notes:
  - Fits all Hager track styles except 9101
  - Screws onto track
  - Included in bi-fold sets 9570 and 9890

### Optional Components

- |      |                        |
|------|------------------------|
| 9121 | Adj. Bottom Door Guide |
| 9122 | Bottom Guide Channel   |
| 9566 | Knob                   |
| 9567 | Rose                   |
| 9558 | Wood Knob              |

For optional components see pages 59-63



# Pocket Door Kits



Pocket door aka “doors that vanish”— Hager Companies offer innovative design options for saving space and complementing classic and contemporary decors.

Hager’s pocket-door hardware is ideal for single and bi-parting pocket-door configurations in rough openings from two to four feet.

Steel or aluminum tracks support doors up to 250 lbs. and are designed for simple installation and durable performance. Hager’s 4-wheel spring carrier design provides an ultra-smooth gliding movement.

Pocket door hardware is available in kits (by opening length) or individual components.

Pocket frame kits include all the framing and hardware components to make installing pocket doors easy. KV offers frame kit solutions for traditional 2 x 4 framing, as well as 2 x 6 framing applications.



## POCKET - 9110 & 9130 PACKAGED SETS

### FEATURES

- Extra heavy duty aluminum I-beam track and hardware
- Conforms to ANSI A156.14
- Type: D8681, D8711

### SPECIFICATIONS

- For doors 1" - 1-3/4" (25 mm - 44 mm) thick doors
- 9110 Packaged Sets up to 175 lbs (80 kg) per door
- 9130 Packaged Sets up to 275 lbs (125 kg) per door
- Track is extruded aluminum jump-proof style with "I" beam track
- Hangers have 1" (25 mm) diameter wheels

Part Number	Description
<b>9110 Packaged Set</b> Includes one (1) 9101 track and one (1) 9109 parts bag: two (2) 9102 hangers, and one (1) 9115 floor guide	
9110-60	Pocket Door Set - 5' (1524 mm) for 2'6" (762 mm) door
9110-72	Pocket Door Set - 6' (1829 mm) for 3'0" (914 mm) door
9110-84	Pocket Door Set - 7' (2134 mm) for 3'6" (1067 mm) door
9110-96	Pocket Door Set - 8' (2438 mm) for 4'0" (1219 mm) door
9110-120	Pocket Door Set - 10' (3048 mm) for 5'0" (1524 mm) door
9110-144	Pocket Door Set - 12' (3658 mm) for 6'0" (1829 mm) door
<b>9130 Packaged Set</b> Includes one (1) 9101 track and one (1) 9129 parts bag: two (2) 9105 hangers, and one (1) 9115 floor guide	
9130-60	Pocket Door Set - 5' (1524 mm) for 2'6" (762 mm) door
9130-72	Pocket Door Set - 6' (1829 mm) for 3'0" (914 mm) door
9130-84	Pocket Door Set - 7' (2134 mm) for 3'6" (1067 mm) door
9130-96	Pocket Door Set - 8' (2438 mm) for 4'0" (1219 mm) door
9130-120	Pocket Door Set - 10' (3048 mm) for 5'0" (1524 mm) door
9130-132	Pocket Door Set - 11' (3353 mm) for 5'6" (1676 mm) door
9130-144	Pocket Door Set - 12' (3658 mm) for 6'0" (1829 mm) door

Part Number	Description
Tracks for use with 9110 Series and 9130 Series	
9101-72	72" (1829 mm) Aluminum I-Beam Track
9101-84	84" (2134 mm) Aluminum I-Beam Track
9101-96	96" (2438 mm) Aluminum I-Beam Track
9101-120	120" (3048 mm) Aluminum I-Beam Track
9101-144	144" (3658 mm) Aluminum I-Beam Track
9101-192	192" (4877 mm) Aluminum I-Beam Track

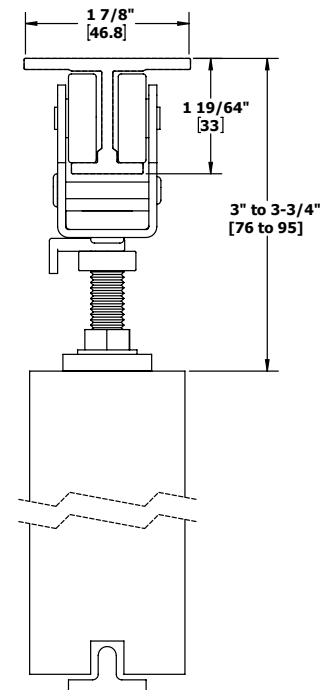
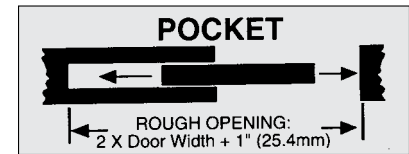

Optional Bottom Track  
9121 - 9122

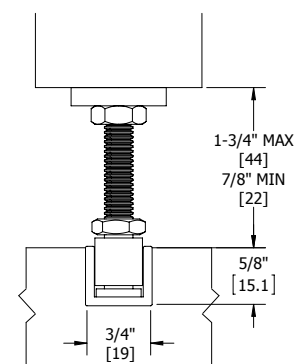

Installation note: Clearance between door bottom and top of 9122 track must be 7/8" (22 mm) minimum to 1-3/4" (44 mm) maximum.



## POCKET - 9110 & 9130 TRACK COMPONENTS



### 9101

#### Aluminum I-Beam Track

Materials: Extruded aluminum  
 Gauge: 0.125" (3 mm) thick  
 Lengths: 72" (1829 mm) to 192" (4877 mm)

- Notes:
- Mounting holes are pre-punched for ease of installation
  - Requires two sets for by-pass opening



### 3835

#### Small Case Deadlock

See page 63 for details



### 9109

#### Parts Bag

Includes two (2) 9102 2-wheel hangers and one (1) 9115 floor guide

Note: Up to 175 lbs (79 kg) per door



### 9129

#### Parts Bag

Includes two (2) 9105 2-wheel hangers and one (1) 9115 floor guide

Note: Up to 275 lbs (125 kg) per door



### 9102

#### 2 Wheel Hanger

Materials: Zinc plated steel  
 Wheels:
 

- Nylon with Steel Ball Bearings
- Two self-aligning wheel hangers allow consistent contact with track

 Hanger: 1-3/16" x 2" x 1-1/8" (46 mm x 51 mm x 29 mm)  
 Bolt: 3/8" x 2-5/16" (10 mm x 59 mm) (Bolt not same as 9105)  
 Top Plate: 1" x 3-1/2" x 3/16" (25 mm x 89 mm x 5 mm)  
 Notes:
 

- Use with 9101 track
- Up to 175 lbs (79 kg) per door



### 9105

#### 4 Wheel Hanger

Materials: Zinc plated steel  
 Wheels: Nylon with steel ball bearings  
 Hanger:
 

- 4" x 2" x 1-3/4" (102 mm x 51 mm x 45 mm)
- Up to 275 lbs (125 kg) per door

 Bolt: 3/8" x 2-5/16" (10 mm x 59 mm)  
 Top Plate: 1" x 3-1/2" x 3/16" (25 mm x 89 mm x 5 mm)  
 Notes:
 

- Use with 9101 track, with doors weighing up to 275 lbs (125 kg)
- Four self-aligning wheel hangers allow consistent contact with track



### 9115

#### Bottom Door Guide

Materials: Die cast zinc aluminum alloy  
 Guide: 7/8" x 3/4" x 3" (22 mm x 19 mm x 76 mm)  
 Notes: Door bottom prep requires 1/4" (6 mm) wide kerf and 9/16" (14 mm) depth

### Optional Components

9111	Fixed Bottom Guide
9113	Stop
9114	Bottom Guide Rail
9884	Pocket Door Edge Pull

For optional components see pages 59-63

## POCKET - 9678 POCKET DOOR SET

### FEATURES

- Heavy duty aluminum box track and hardware
- Conforms to ANSI A156.14
- Type: D8681, D8711

### SPECIFICATIONS

- For doors 1-1/8" - 1-3/4" (29 mm - 44 mm) thick
- Up to 125 lbs (57 kg) per door with 9605 hangers
- Up to 150 lbs (68 kg) per door with 9606 hangers
- Track is extruded aluminum jump-proof style with "V" shaped rails
- Hangers have four 7/8" (22 mm) diameter wheels for 9605 and wheels mounted on ball bearing shafts for 9606

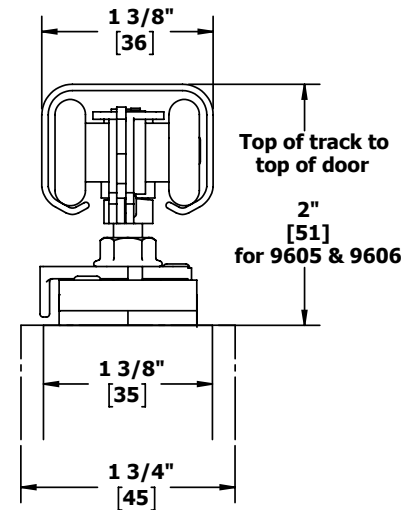
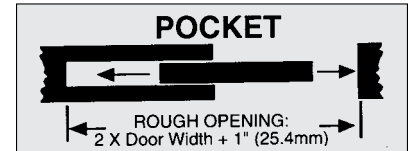

Part Number	Description
9678	Pocket Door Set for 125 lb. doors Includes one (1) 9601 track and one (1) 9632 parts bag: two (2) 9605 hangers, two (2) 9883 guides, and one (1) 9881 bumper
9678-72	Pocket Door Set - 6' (1829 mm) for 3'0" (914 mm) door
9678-96	Pocket Door Set - 8' (2438 mm) for 4'0" (1219 mm) door

### TRACKS - 0.05" (1.3 mm) thick aluminum

Part Number	Description
Tracks for use with 9601 Series	
9601-35	35" (889 mm) Aluminum Box Track
9601-47	47" (1194 mm) Aluminum Box Track
9601-55	55" (1397 mm) Aluminum Box Track
9601-59	59" (1499 mm) Aluminum Box Track
9601-63	63" (1600 mm) Aluminum Box Track
9601-71	71" (1803 mm) Aluminum Box Track
9601-96	96" (2438 mm) Aluminum Box Track
9601-120	120" (3048 mm) Aluminum Box Track
9601-144	144" (3658 mm) Aluminum Box Track

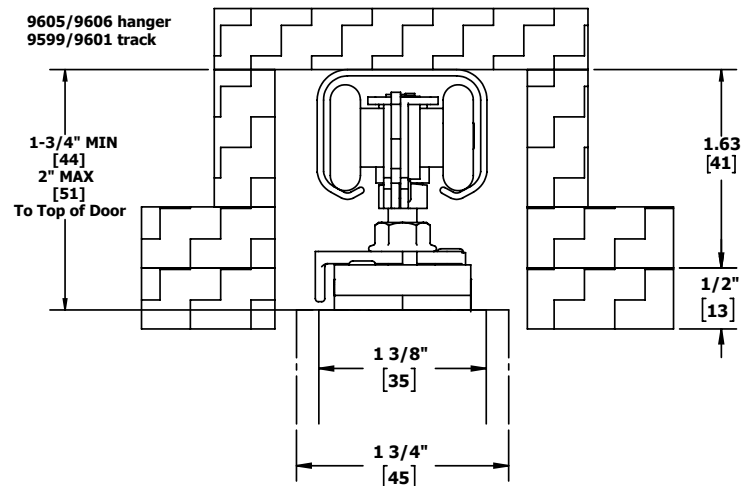



## POCKET - 9678 TRACK COMPONENTS



### 9601

#### Aluminum Box Track

- Materials: Extruded aluminum  
 Gauge: 0.050" (1.3 mm)  
 Track: 1-1/16" x 1-3/8"  
 (27 mm x 35 mm)  
 Lengths: 35" (889 mm) to 144"  
 (3657 mm)  
 Notes:
- Refer to series pages for weight capacities
  - Jump proof twin channel design



### 3835

#### Small Case Deadlock

See page 63 for details



### 9632

#### Parts Bag

Includes two (2) 9605 hangers, two (2) 9883 guides, and one (1) 9881 bumper



### Optional Part Bags

#### 9633

#### Parts Bag

Includes two (2) 9606 hangers, two (2) 9883 guides, and one (1) 9881 bumper  
 \* For doors weighing up to 150 lbs. (68 kg)



### 9605

#### 4-Wheel Hanger

- Materials: Steel with brass-tone dichromate finish  
 Wheel: 7/8" (22 mm) diameter  
 Notes:
- Up to 125 lbs (57 kg) per door
  - Self-aligning to allow consistent contact with track
  - Pre-lubricated Celcon wheels mounted on steel ball bearing shafts
  - Can be used on pivot set
  - Use in conjunction with 9601 or 9602 track



### 9606

#### 4-Wheel Ball Bearing Hanger

- Materials: Steel with brass-tone dichromate finish  
 Wheel: 7/8" (22 mm) diameter  
 Notes:
- Up to 150 lbs (68 kg) per door
  - Self-aligning to allow consistent contact with track
  - Pre-lubricated Celcon wheels mounted on steel ball bearing shafts
  - Used in conjunction with 9607, 9608 or 9610 top door plate and 9599, 9601 or 9602 track



### 9883

#### Two Piece Pocket Door Guide

- Materials: Polyethylene  
 Guide: 1-3/16" x 3/4" x 1-1/8"  
 (21 mm x 19 mm x 29 mm)  
 Notes:
- Two pieces per door required
  - Screws to jamb to guide door and prevent rubbing



### 9881

#### Bumper

- Materials: Rubber  
 Stop: 1/2" diameter x 3/8" deep  
 (13 mm x 10 mm)  
 Notes: With screws

### Optional Components

330D	Pocket Door Latch
330L	Pocket Door Privacy Latch
330M	Pocket Door Privacy Latch
2630	Flush Cup Pull
9884	Pocket Door Edge Pull
9815	Bumper Stop
9889	Non-Adjustable Floor Guide

For optional components see pages 59-63

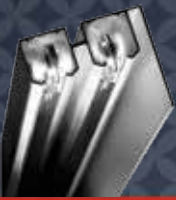

## POCKET - 9878 PACKAGED SETS

### FEATURES

- Extra heavy duty aluminum box track and hardware
- Conforms to ANSI A156.14
- Type: D8681, D8711

### SPECIFICATIONS

- For doors 1-3/8" - 1-3/4" (35 mm - 44 mm) thick
- Up to 250 lbs (113 kg) per door
- Track is extruded aluminum jump-proof style with "V" shaped rails
- Hangers have four 1-1/4" (32 mm) diameter wheels

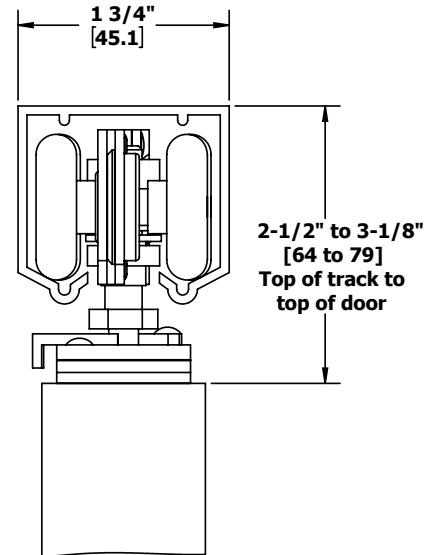
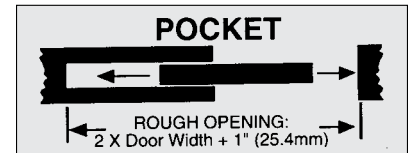

*Interchanges with Stanley 57/58.*

Part Number	Description
9878 Series Set	Includes one (1) 9801 track and one (1) 9742 parts bag
9878-72	Pocket Door Set - 6' (1829 mm) for 3'0" (914 mm) door
9878-96	Pocket Door Set - 8' (2438 mm) for 4'0" (1219 mm) door

### TRACKS - 0.075" (1.9 mm) thick aluminum

Part Number	Description
Tracks for use with 9801 Series	
9801-72	72" (1829 mm) Aluminum Box Track
9801-96	96" (2438 mm) Aluminum Box Track
9801-120	120" (3048 mm) Aluminum Box Track
9801-144	144" (3658 mm) Aluminum Box Track
9801-192	192" (4877 mm) Aluminum Box Track







## POCKET - 9878 TRACK COMPONENTS



### 9801

#### Extra Heavy Duty Box Track

- Materials: Extruded aluminum  
 Gauge: 0.075" (1.9 mm)  
 Track: 1-5/8" x 1-3/4"  
 (41 mm x 44 mm)  
 Lengths: 72" (1829 mm) to 192"  
 (4877 mm)  
 Notes:
  - For doors up to 250 lbs (113 kg)
  - Jump proof twin channel design



### 3835

#### Small Case Deadlock

- Thumbturn: Meet ADA Requirements, "No pinch," "No grasp."  
 Lock Case: Heavy wrought steel with zinc dichromate finish - 4-5/16" x 3-9/16" x 1" (110 mm x 90 mm x 25 mm)  
 Armor Front: 1-1/4" x 5-5/8" x 7/32" (32 mm x 143 mm x 5 mm)  
 Keys: Two operating keys supplied per lock  
 Cylinder:
  - Brass - keyed different - C keyway - Standard
  - Other keying options, including keyed 6-pin, available from factory
  - SFIC uncombined or combined, brass 6- or 7-pin sold separately
  - Drilled 6-pin, keyed 5-pin - Standard
  - Small Format Interchangeable Core housing available
  - Schlage "L" cam - Standard
 Door Thickness:
  - 1-3/8" - 2-1/2" (35mm-64mm) - steel door
  - 1-3/4" - 2-1/2" (45mm-64mm)- wood door
  - Must specify door thickness if greater than 1-3/4" (45mm)
 Backset: 2-3/4" (70 mm) only  
 Deadbolt:
  - 1" (25 mm) throw - stainless steel
 Strike:
  - 1 1/8" wide x 3 1/2" (29mm x 89mm) NO LIP
 Finishes: US26D  
 Functions: 35-Cylinder x Thumbturn, 36-Single Cylinder, 37-Double Cylinder, 38-Thumbturn Only, 39-Thumbturn w/ Emergency Key



### 9742

#### Parts Bag

- Includes two (2) 9827 hangers, two (2) 9883 guides, and one (1) 9881 bumper



### 9827

#### Four Wheel Ball Bearing Hanger

- Materials: Zinc plated steel  
 Wheels: Self aligning to allow consistent contact with track  
 Wheel: 1-1/4" (32 mm) diameter  
 Notes:
  - For doors up to 75 lbs (34 kg)
  - Pre-lubricated Celcon wheels on steel shafts with steel ball bearings
  - Ball bearing axles
  - For use with 9801 track



### 9881

#### Bumper

- Materials: Rubber  
 Stop: 1/2" diameter x 3/8" deep (13 mm x 10 mm)  
 Notes: With screws



### 9883

#### Two Piece Pocket Door Guide

- Materials: Polyethylene  
 Guide: 1-3/16" x 3/4" x 1-1/8" (21 mm x 19 mm x 29 mm)  
 Notes:
  - Two pieces per door required
  - Screws to jamb to guide door and prevent rubbing

### Optional Components

- |      |                            |
|------|----------------------------|
| 330D | Pocket Door Latch          |
| 330L | Pocket Door Privacy Latch  |
| 330M | Pocket Door Privacy Latch  |
| 2630 | Flush Cup Pull             |
| 9884 | Pocket Door Edge Pull      |
| 9815 | Bumper Stop                |
| 9884 | Pocket Door Edge Pull      |
| 9889 | Non-Adjustable Floor Guide |

For optional components see pages 59-63

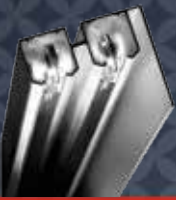

## POCKET - 9901 SERIES

### FEATURES

- Extra heavy duty aluminum box track and hardware
- Conforms to ANSI A156.14
- Type: D8681

### SPECIFICATIONS

- For doors 1-3/8" - 1-3/4" (35 mm - 44 mm) thick
- Up to 250 lbs (113 kg) per door
- Quick release hangers allow easy door hanging and removal
- Hangers interchange with Stanley & Johnson track and hangers
- Universal extruded aluminum track interchanges with Stanley & Johnson track and hangers
- Hangers have 1" (25 mm) diameter ball bearing wheels

Part Number	Description
9901 Series Set	Includes one (1) 9821 track and one (1) 9895 parts bag: two (2) 9825 hangers, two (2) 9883 guides, and one (1) 9881 bumper
9901-72	Pocket Door Set - 6' (1829 mm) for 3'0" (914 mm) door
9901-96	Pocket Door Set - 8' (2438 mm) for 4'0" (1219 mm) door

### TRACKS - 0.06" (1.5 mm) thick aluminum

Part Number	Description
Tracks for use with 9901 Series	
9821-59	59" (1499 mm) Aluminum Box Track
9821-71	71" (1803 mm) Aluminum Box Track
9821-96	96" (2438 mm) Aluminum Box Track
9821-144	144" (3658 mm) Aluminum Box Track

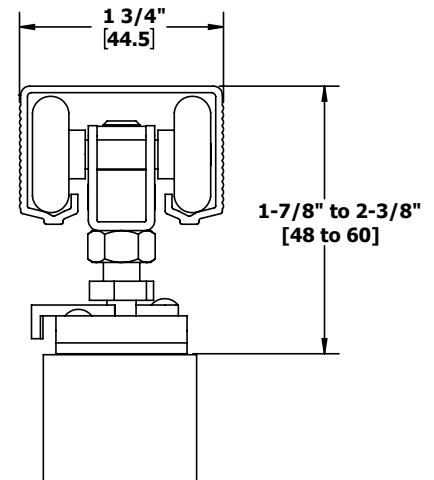
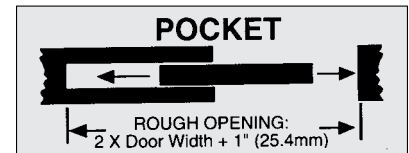

*Interchanges with Stanley 125/250 Series and Johnson 100 Series.*





## POCKET - 9901 SERIES TRACK COMPONENTS



### 9821

#### Aluminum Box Track

- Materials: Extruded aluminum  
 Gauge: 0.06" (1.55 mm)  
 Track: 1-5/8" x 1-1/16"  
 (41 mm x 27 mm)  
 Lengths: 59" (1499 mm) to 144"  
 (3658 mm)  
 Notes:
  - For doors up to 250 lbs (113 kg)
  - Jump proof twin channel design



### 3835

#### Small Case Deadlock

- Thumbturn: Meet ADA Requirements, "No pinch," No grasp."  
 Lock Case: Heavy wrought steel with zinc dichromate finish - 4-5/16" x 3-9/16" x 1" (110 mm x 90 mm x 25 mm)  
 Armor Front: 1-1/4" x 5-5/8" x 7/32" (32 mm x 143 mm x 5 mm)  
 Keys: Two operating keys supplied per lock  
 Cylinder:
  - Brass - keyed different - C keyway - Standard
  - Other keying options, including keyed 6-pin, available from factory
  - SFIC uncombined or combined, brass 6- or 7-pin sold separately
  - Drilled 6-pin, keyed 5-pin - Standard
  - Small Format Interchangeable Core housing available
  - Schlage "L" cam - Standard
 Door Thickness:
  - 1-3/8" - 2-1/2" (35mm-64mm) - steel door
  - 1-3/4" - 2-1/2" (45mm-64mm)- wood door
  - Must specify door thickness if greater than 1-3/4" (45mm)
 Backset: 2-3/4" (70 mm) only  
 Deadbolt: 1" (25 mm) throw - stainless steel  
 Strike: 1 1/8" wide x 3 1/2" (29mm x 89mm) NO LIP  
 Finishes: US26D  
 Functions: 35-Cylinder x Thumbturn, 36-Single Cylinder, 37-Double Cylinder, 38-Thumbturn Only, 39-Thumbturn w/ Emergency Key



### 9895

#### Parts Bag

- Includes two (2) 9825 4-wheel ball bearing hangers with quick release top plate, two (2) 9883 guides, and one (1) 9881 bumper



### 9825

#### 4 Wheel Ball Bearing Hanger with Quick Release Top Mount Plate

- Materials: Zinc plated steel  
 Wheels: Self aligning to allow consistent contact with track  
 Wheel: 1" (25 mm) diameter  
 Notes:
  - Pre-lubricated Celcon wheels
  - Up to 250 lbs (113 kg) doors
  - For use with 9821 track
  - Quick release feature allows easy door hanging and removal



### 9883

#### Two Piece Pocket Door Guide

- Materials: Polyethylene  
 Guide: 1-3/16" x 3/4" x 1-1/8"  
 (21 mm x 19 mm x 29 mm)  
 Notes:
  - Two pieces per door required
  - Screws to jamb to guide door and prevent rubbing



### 9881

#### Bumper

- Materials: Rubber  
 Stop: 1/2" diameter x 3/8" deep  
 (13 mm x 10 mm)  
 Notes: With screws

### Optional Components

- |      |                            |
|------|----------------------------|
| 330D | Pocket Door Latch          |
| 330L | Pocket Door Privacy Latch  |
| 330M | Pocket Door Privacy Latch  |
| 2630 | Flush Cup Pull             |
| 9559 | Aligner                    |
| 9815 | Bumper Stop                |
| 9884 | Pocket Door Edge Pull      |
| 9889 | Non-Adjustable Floor Guide |

For optional components see pages 59-63

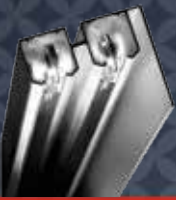

**POCKET - 9628 | 9629 | 9630 | 9631**

**FEATURES**

- Heavy duty pocket door kit
- Conform to ANSI A156.14
- Type: D8671, D8701

**SPECIFICATIONS**

- Jump proof track and rollers
- Pre-assembled header assembly goes up quickly
- Easy door installation and removal for painting and repair
- Real wood split studs, size 3/4" x 1-5/8" (19 mm x 26 mm) length relative to height, steel encased for rigidity and to prevent fastener penetration into the pocket
- Track header unit attaches to rough framing at both ends - split studs nail or screw to track header - no connections to rough header
- 2 pair of split studs with wood inserts
- See chart below for appropriate kit



Part #	Max Door Weight	Door Thickness*	Door Width	Door Height	Hanger Bearings
9628	150 lbs (68 kg)	1-3/8" - 1-3/4" (35 mm - 44 mm)	3'0" (914 mm)	9'0" (2743 mm)	9606 Steel Ball
9629	150 lbs (68 kg)	1-3/8" - 1-3/4" (35 mm - 44 mm)	3'0" (914 mm)	8'0" (2438 mm)	9606 Steel Ball
9630	150 lbs (68 kg)	1-3/8" - 1-3/4" (35 mm - 44 mm)	3'0" (914 mm)	7'0" (2134 mm)	9606 Steel Ball
9631	125 lbs (57 kg)	1-3/8" - 1-3/4" (35 mm - 44 mm)	3'0" (914 mm)	6'8" (2032 mm)	9605 Molded Celcon

\* 9634 adapter kit is recommended for 1-3/4" (45 mm) doors (sold separately).

Installation Note: For bi-parting doors, use Hager double pocket door kit 9639 (sold separately).



Joins two pocket door frames to make one large doorway. Rough opening width changes to door width multiplied by four.

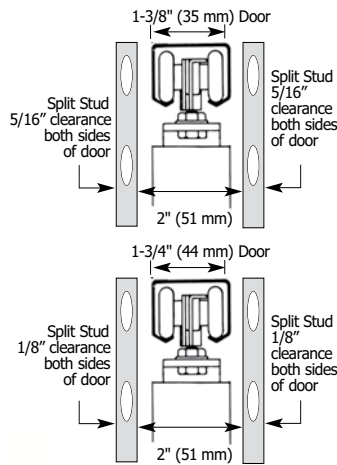
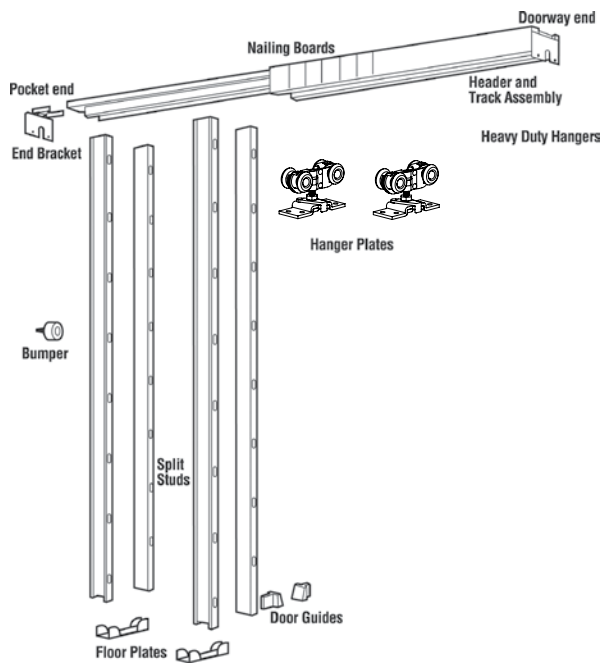

Note: 9634 adapter kit (sold separately) recommended for doors 1-3/4" (45 mm) thick.

**Contents**

Quantity	Description
1	Header assembly
2	Pair of split studs
2	Heavy duty hangers
2	Door hanger plates
1	Bumper
1	Pair of door guides
1	Adjusting wrench
2	Floor plates
1	Doorway end bracket
1	Pocket end bracket



## POCKET - 9850

### FEATURES

- Heavy duty pocket door kit
- Conform to ANSI A156.14
- Type: D8671, D8701

# Pocket Door Kit

### SPECIFICATIONS

- For doors 1-3/8" - 1-3/4" (35 mm - 44 mm) thick, up to 4'0" (1219 mm) wide and 8'0" (2438 mm) or 8'6" (2591 mm) high, weighing up to 250 lbs (112 kg)
- Jump proof track and rollers
- 9801 heavy duty aluminum box track
- Pre-assembled header assembly goes up quickly
- Easy door installation and removal for painting and repair
- Real wood split studs, size 3/4" x 1-5/8" (19 mm x 26 mm) length relative to height, steel encased for rigidity and to prevent fastener penetration into the pocket
- Track header unit attaches to rough framing at both ends - split studs nail or screw to track header - no connections to rough header
- 3 pair of split studs with wood inserts

Part #	Max Door Weight	Door Thickness*	Door Width	Door Height	Hanger Bearings
9850	250 lbs (57 kg)	1-3/8" - 1-3/4" (35 mm - 44 mm)	4'0" (1219 mm)	8'0" (2438 mm)	9829 Steel Ball

Installation Note: For bi-parting doors, use Hager double pocket door kit 9639 (sold separately).

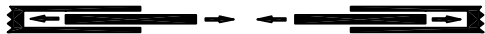

Joins two pocket door frames to make one large doorway. Rough opening width changes to door width multiplied by four.

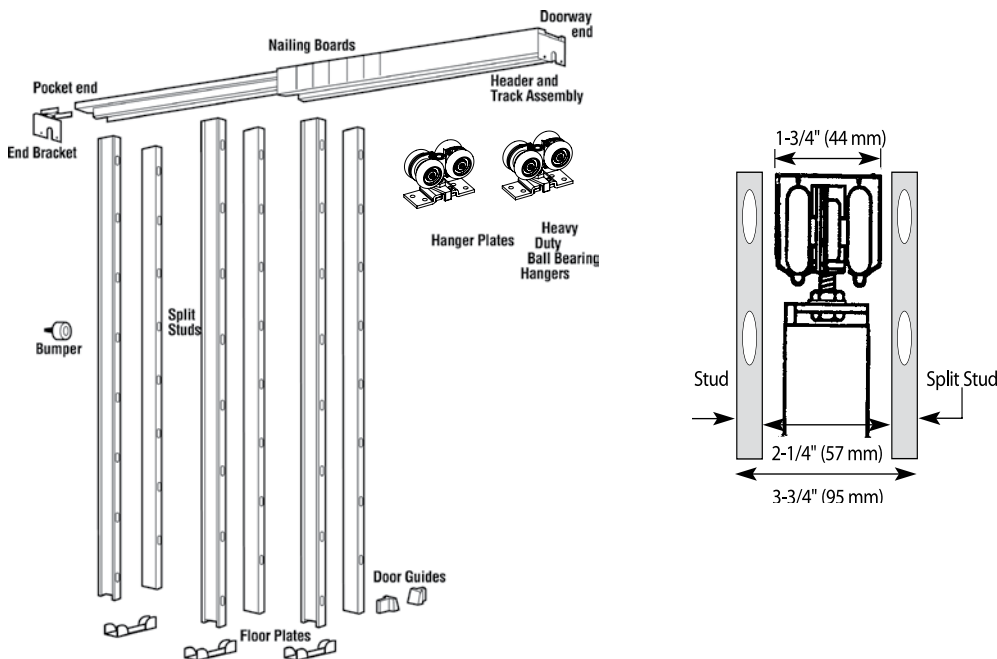

### Contents

Quantity	Description
1	Header assembly
3	Pair of split studs
2	Heavy duty hangers
2	Door hanger plates
1	Bumper
1	Pair of door guides
1	Adjusting wrench
3	Floor plates
1	Doorway end bracket
1	Pocket end bracket

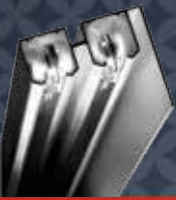

## POCKET - POCKET DOOR KIT COMPONENTS



### 330D

#### Pocket Door Latch

Certification: Meets ANSI A156.14 for D0821.1

Size: 2-3/4" x 2-1/2"  
(70 mm x 64 mm)

Finger Piece: 1-3/8" (35 mm) extension

Materials: Brass

Finishes: US3, US5, US10B, US15, US15A, US19, US26, US26D

Fasteners: Two (2) #6 x 5/8" OPHWS; (2) #6 x 3/4" FPHWS

Notes: For use with 1-3/8" to 1-3/4" (35 mm to 45 mm) door



### 2610

#### Flush Cup Finger Pull

Overall Diameter: 31/32" (25 mm)

Finger Pull: 3/4" (19 mm) diameter

Depth: 5/16" (8 mm)

Projection: 1/32" (.8 mm)

Materials: Solid brass

Finishes: US3, US4, US5, US10A, US15, US15A, US26, US26D, ABA

Notes: Built-in prong design eliminates the need for screws or brads.



### 330L

#### Pocket Door Privacy Latch

Size: 2-3/4" x 2-1/2"  
(70 mm x 64 mm)

Finger Piece: 1-3/8" (35 mm) extension

Strike Size: 1" x 2-1/4" (25 mm x 57 mm)

Materials: Brass

Finishes: US3, US5, US10B, US15, US15A, US19, US26, US26D

Fasteners: Two (2) #6 x 5/8" OPHWS; (2) #6 x 3/4" FPHWS

Notes: For use with 1-3/8" door



### 2630

#### Flush Cup Pull

Overall Diameter: 2-7/16" (62 mm)

Finger Pull: 2-1/16" (52 mm) diameter

Depth: 11/32" (9 mm)

Projection: 3/32" (2 mm)

Materials: Solid brass

Finishes: US3, US4, US5, US10A, US15, US15A, US26, US26D, ABA

Notes: Built-in prong design eliminates the need for screws or brads.



### 330M

#### Pocket Door Privacy Latch

Certifications: Meets ANSI A156.14 for D0831

Size: 2-3/4" x 2-1/2"  
(70 mm x 64 mm)

Finger Piece: 1-3/8" (35 mm) extension

Strike Size: 1" x 2-1/4" (25 mm x 57 mm)

Materials: Brass

Finishes: US3, US5, US10B, US15, US15A, US19, US26, US26D

Fasteners: Two (2) #6 x 5/8" OPHWS; (2) #6 x 3/4" FPHWS

Notes: For use with 1-3/4" door



### 9605

#### 4-Wheel Hanger

Materials: Steel with brass-tone dichromate finish

Wheel: 7/8" (22 mm) diameter

Notes:

- For doors up to 125 lbs (57 kg)
- Wheels are self aligning to allow consistent contact with track
- Pre-lubricated Celcon wheels mounted on steel ball bearing shafts
- Can be used on pivot set
- Use in conjunction with 9601 or 9602 track





## POCKET - POCKET DOOR KIT COMPONENTS



### 9606 4-Wheel Ball Bearing Hanger with Top Mount Plate

- Materials: Steel with brass-tone dichromate finish
- Wheels: 7/8" (22 mm) diameter
- Notes:
- Self aligning to allow consistent contact with track
  - Pre-lubricated Celcon wheels mounted on steel ball bearing shafts
  - Up to 150 lbs (68 kg) per door
  - Use with 9601, 9602, or 9603 track



### 3835 Small Case Deadlock

- Thumbturn: Meet ADA Requirements, "No pinch," No grasp."
- Lock Case: Heavy wrought steel with zinc dichromate finish - 4-5/16" x 3-9/16" x 1" (110 mm x 90 mm x 25 mm)
- Armor Front: 1-1/4" x 5-5/8" x 7/32" (32 mm x 143 mm x 5 mm)
- Keys: Two operating keys supplied per lock
- Cylinder:
- Brass - keyed different - C keyway - Standard
  - Other keying options, including keyed 6-pin, available from factory
  - SFIC uncombined or combined, brass 6- or 7-pin sold separately
  - Drilled 6-pin, keyed 5-pin - Standard
  - Small Format Interchangeable Core housing available
  - Schlage "L" cam - Standard
- Door Thickness:
- 1-3/8" - 2-1/2" (35mm-64mm) - steel door
  - 1-3/4" - 2-1/2" (45mm-64mm)- wood door
  - Must specify door thickness if greater than 1-3/4" (45mm)
- Backset: 2-3/4" (70 mm) only
- Deadbolt:
- 1" (25 mm) throw - stainless steel
- Strike:
- 1 1/8" wide x 3 1/2" (29mm x 89mm) NO LIP
- Finishes: US26D
- Functions: 35-Cylinder x Thumbturn, 36-Single Cylinder, 37-Double Cylinder, 38-Thumbturn Only, 39-Thumbturn w/ Emergency Key



### 9632 Parts Bag

- Includes:
- Two (2) 9605 hangers
  - Two (2) 9883 guides
  - One (1) 9881 bumper



### 9633 Parts Bag

- Includes:
- Two (2) 9606 hangers
  - Two (2) 9883 guides
  - One (1) 9881 bumper



### 9827 Four Wheel Ball Bearing Hanger

- Materials: Zinc plated steel
- Wheels: Self aligning to allow consistent contact with track
- Wheel: 1-1/4" (32 mm) diameter
- Notes:
- For doors up to 75 lbs (34 kg)
  - Pre-lubricated Celcon wheels on steel shafts with steel ball bearings
  - Ball bearing axles
  - For use with 9801 track

### Optional Components

- |      |                              |
|------|------------------------------|
| 9610 | Replacement Top Mount Plate  |
| 9634 | Pocket Door Adaptor Kit      |
| 9639 | Dbl. Pocket Door Adapter Kit |
| 9865 | Flush Cup Pull               |
| 9881 | Bumper                       |
| 9883 | Two Piece Pocket Door Guide  |
| 9884 | Pocket Door Edge Pull        |
| 9889 | Non-Adjustable Floor Guide   |
| 9262 | Pocket Door Keyed Lock       |
| 9877 | Door Guide                   |

For optional components see pages 59-63





# Wall-Mount Hardware



*Architecturally designed wall-mount system for commercial or residential spaces*

Hager Companies wall-mount sliding door hardware is designed to blend seamlessly with any interior décor — from a contemporary uptown loft, to any more traditional environment. This architecturally focused design delivers a clean, finished look to any interior doorway or room divider (from two to six opening feet) while providing maximum space utilization.

Hager's 9710 Wall-Mount system is available in clear anodized and dark bronze finishes. Quiet four-wheel ball bearing carriers support doors up to 250 lbs. Hardware supports one- and two-door applications.

Wall-mount door hardware is available in kits (by track length) or individual components.



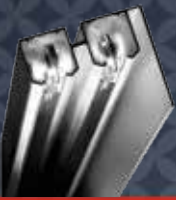

## WALL MOUNT - 9710

### FEATURES

- Heavy duty aluminum box track and hardware
- Conforms to ANSI BHMA A156.14-2007
- Grade 1, D8011, D8681, D8691
- Grade 2, D8012, D8692
- Bi-parting Grade 1, D8711
- Grade 2, D8721

### SPECIFICATIONS

- For doors 1" - 1-3/4" (25 mm - 45 mm) thick
- Up to 250 lbs (113 kg) per door
- Track is extruded aluminum jump-proof style
- Hangers have four 1-1/4" (32 mm) diameter wheels

Part Number	Description	Stock#
9710 Packaged Set		
Includes one (1) 9703 track, one (1) 9704 anodized fascia, one (1) 9705 end caps and one (1) 9711 parts bags.		
9710-60	Wall Mount Packaged Set- Aluminum 5' (1524mm) for 1 Door	160955
9710-72	Wall Mount Packaged Set- Aluminum 5' (1524mm) for 1 Door	160958
9710-96	Wall Mount Packaged Set- Aluminum 8' (1219mm) for 1 Door	160959
9710-144	Wall Mount Packaged Set- Aluminum 12' (1829mm) for 1 Door	160991

Part Number	Description	Stock#
9710 Packaged Set		
Includes one (1) 9703 track, one (1) 9704 anodized fascia, one (1) 9705 end caps and one (1) 9711 parts bags.		
9710-60	Wall Mount Packaged Set- Dark Bronze 5' (1524mm) for 1 Door	160961
9710-72	Wall Mount Packaged Set- Dark Bronze 5' (1524mm) for 1 Door	160962
9710-96	Wall Mount Packaged Set- Dark Bronze 8' (1219mm) for 1 Door	160963
9710-144	Wall Mount Packaged Set- Dark Bronze 12' (1829mm) for 1 Door	160989

**TRACKS** One track required for each Wall Mount opening-.125 (3.2 mm) thick aluminum

Part Number	Description	Stock#
9703 Wall Mount Etched Aluminum Finish Tracks for use with 9710 Series		
9703-60	Wall Mount Track- Aluminum 5' (1524mm) for 1 Door	160984
9703-72	Wall Mount Track- Aluminum 6' (1839 mm) for 1 Door	160985
9703-96	Wall Mount Track- Aluminum 8' (1219mm) for 1 Door	160986
9703-144	Wall Mount Track- Aluminum 12' (1829mm) for 1 Door	160988

9703 Wall Mount Dark Bronze Finish Tracks for use with 9710 Series		
9703-60	Wall Mount Track- Dark Bronze 5' (1524mm) for 1 Door	160993
9703-72	Wall Mount Track- Dark Bronze 6' (1839 mm) for 1 Door	160994
9703-96	Wall Mount Track- Dark Bronze 8' (1219mm) for 1 Door	160995
9703-144	Wall Mount Track- Dark Bronze 12' (1829mm) for 1 Door	160996

### WALL MOUNT



9827 Hanger

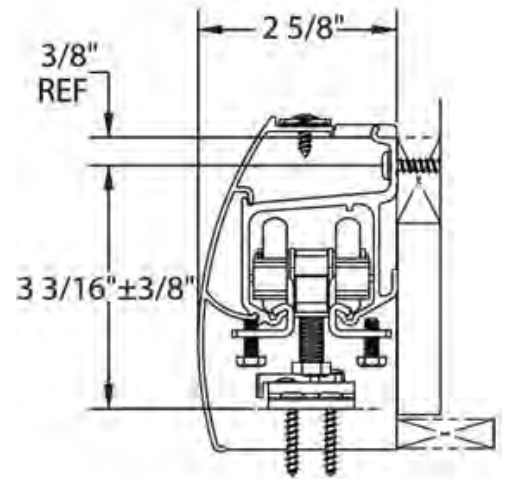

*Interchanges with Stanley 57/58.*





## WALL MOUNT - 9710

**FASCIA** One anodized fascia required for each Wall Mount opening-.825 (2.1 mm) thick aluminum

Part Number	Description	Stock#
9704 Wall Mount Anodized Aluminum Finish Fascia for use with 9710 Series		
9704-60	Wall Mount Fascia- Anodized Aluminum 5' (1524mm) for 1 Door	160984
9704-72	Wall Mount Fascia- Anodized Aluminum 6' (1839 mm) for 1 Door	160985
9704-96	Wall Mount Fascia- Anodized Aluminum 8' (1219mm) for 1 Door	160986
9704-144	Wall Mount Fascia- Anodized Aluminum 12' (1829mm) for 1 Door	160988

9704 Wall Mount Anodized Dark Bronze finish Fascia for use with 9710 Series		
9704-60	Wall Mount Fascia- Anodized Dark Bronze 5' (1524mm) for 1 Door	160993
9704-72	Wall Mount Fascia- Anodized Dark Bronze 6' (1839 mm) for 1 Door	160994
9704-96	Wall Mount Fascia- Anodized Dark Bronze 8' (1219mm) for 1 Door	160995
9704-144	Wall Mount Fascia- Anodized Dark Bronze 12' (1829mm) for 1 Door	160996

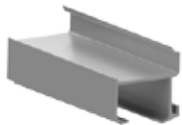

### 9703

#### Extra Heavy Duty Box Track

Materials: Extruded aluminum  
 Gauge: .125 (3.2 mm) thick  
 Lengths: 60" (1524 mm) to 144" (1829 mm)

- Notes:
- For doors up to 250 lbs (113 kg)
  - Jump proof track with twin channel design



### 9705

#### End Cap Sets

- Materials: Anodized aluminum  
 Notes:
- Concealed fasteners provide a finished look
  - One each left and right end cap and hardware

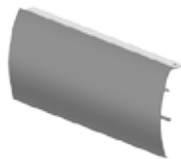

### 9704

#### Smooth Anodized Fascia

Materials: Anodized aluminum  
 Gauge: .0620 (1.6 mm)  
 Fascia: 4 3/8" (111 mm)  
 Lengths: 60" (1524 mm) to 144" (1829 mm)



### 9711

#### Parts Bag

Includes: Two (2) each 9827 four wheel ball bearing hanger and quick release top mount plate, One (1) each 9115 bottom door guide, and four (4) each 9815 bumper stop

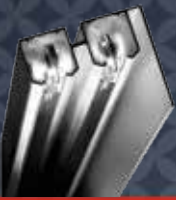

## WALL MOUNT - 9710 COMPONENTS



### 9827

#### Four Wheel Ball Bearing Hanger

- Materials: Zinc plated steel
- Wheels: Self aligning to allow consistent contact with track
- Wheel: 1-1/4" (32 mm) diameter
- Notes:
- For doors up to 250 lbs (113 kg)
  - Pre-lubricated Celcon wheels on steel shafts with steel ball bearings
  - Ball bearing axles
  - For use with 9703 and 9801 track



### 9115

#### Bottom Door Guide

- Materials: Die cast zinc aluminum alloy
- Guide: 7/8" x 3/4" x 3" (22 mm x 19 mm x 76 mm)
- Notes: Door bottom prep requires 1/4" (6 mm) wide kerf and 9/16" (14 mm) depth



### 9815

#### Bumper Stop

- Materials: Zinc plated steel and rubber
- Notes:
- Fits all Hager track styles except 9101
  - Screws onto track
  - Included in 9710 wall mount sets
  - Included in bi-fold sets 9570 and 9890

### Optional Components

9610	Replacement Top Mount Plate
330D	Pocket Door Latch
330L	Pocket Door Privacy Latch
330M	Pocket Door Privacy Latch
9884	Pocket Door Edge Pull

For optional components see pages 59-63

# Barn Door Hardware



Hager Companies introduces our new premium Stainless Steel Sliding Barn Door Hardware System with versatile options for glass or wood doors. A seamless fit for commercial or residential applications, the Stainless Steel Sliding Barn Door Hardware System offers seven styles of door hangers complimenting any décor.



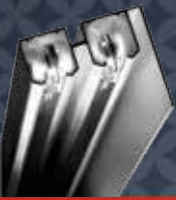

## 9400 SERIES BARN DOOR HARDWARE

### FEATURES

- 304 stainless steel track and hangers nylon coated rollers
- Conforms to ANSI BHMA A156.14-2007
- Grade 1 for sliding doors by exceeding 100,000 cycles in operation

### SLIDING BARN DOOR



### SPECIFICATIONS

- Door weight up to 250 lbs
- Wood doors 1-3/4" thick - top-mount hangers
- Door bottom 3/8" undercut
- Glass doors 3/8" to 1/2" thick - face-mount hangers

Stock Number	Hager Part Number	Description
<b>Stainless Steel 78" Kits</b>		
<b>Top Mount</b>		
183635	9432-78	Top Mount Stick 2m (78-3/4") SS Round Rail
183637	9433-78	Top Mount Dual Wheel 2m (78-3/4") SS Round Rail
183683	9462-78	Flat Rail Stick Strap SS 6' Flat track
183641	9435-78	Top Mount Spoke Wheel 2m (78-3/4") SS Round Rail
<b>Face Mount</b>		
183643	9436-78	Face mount Strap Stick 2m (78-3/4") SS Round Rail
183646	9437-78	Face mount Strap Dual Wheel 2m (78-3/4") SS Round Rail
183650	9438-78	Face mount Strap Triangle 2m (78-3/4") SS Round Rail
<b>Stainless Steel 96" Kits - Subject to Extended Lead Times</b>		
<b>Top Mount</b>		
183636	9432-96	Top Mount Stick 2m (96-3/4") SS Round Rail
183638	9433-96	Top Mount Dual Wheel 2m (96-3/4") SS Round Rail
183640	9462-96	Flat Rail Stick Strap SS 8' Flat track
183642	9435-96	Top Mount Spoke Wheel 2m (96-3/4") SS Round Rail
<b>Face Mount</b>		
183644	9436-96	Face mount Strap Stick 2m (96-3/4") SS Round Rail
183647	9437-96	Face mount Strap Dual Wheel 2m (96-3/4") SS Round Rail
183651	9438-96	Face mount Strap Triangle 2m (96-3/4") SS Round Rail
<b>Accessories</b>		
183156	1-269-8665	Tool set for 05WG; 06WG; 07WG (Round Rail)
183163	1-269-8666	Tool set for 01W; 02W (Round Rail)
183164	1-269-8667	End Cap
183165	1-269-8668	Guide for Wooded Door
183166	1-269-8669	Door Stop
183167	1-269-8670	Guide for Glass Door
183168	1-269-8671	Top Mount Stick Sliding Door Roller for Wood, SS304 Satin
183170	1-269-8672	Top Mount Dual Wheel Sliding Door Roller for Wood, SS304 Satin
183171	1-269-8673	Top Mount Spoke Wheel Sliding Door Roller for Wood, SS304 Satin
183172	1-269-8674	Strap Stick Sliding Door Roller for Wood and Glass, SS304 Satin
183173	1-269-8675	Strap Dual Wheel Sliding Door Roller for Wood and Glass, SS304 Satin
183176	1-269-8676	Strap Triangle Sliding Door Roller for Wood and Glass, SS304 Satin
183179	1-269-8677	Flat Rail Stick Sliding Door Carrier for Wood SS304 Satin
183180	1-269-8678	Flat Rail Door Stopper Left, SS304 Satin
183181	1-269-8679	Flat Rail Door Stopper Right, SS304 Satin
183182	1-269-8680	Flat Rail Anti Jump
181901	1-269-8663	Round Rail Connector SS304 Satin Nickel
181902	1-269-8664	Flat Rail Connector SS304 Satin Nickel





## 9400 SERIES BARN DOOR HARDWARE

### 9432 PACKAGED SETS

#### Top Mount Stick 2m SS Round Rail

##### FEATURES

Materials: 304 stainless steel track and hangers with nylon coated rollers

- System Includes:
- Stainless steel track (78" or 96") with two end caps - available in round or flat rail
  - Hangers with wall brackets
  - One door bottom guide
  - Two track stops
  - Mounting and installation hardware

Standards: Meets performance requirements of ANSI/BHMA 156.14 (Grade 1) for sliding doors by exceeding 100,000 cycles



##### DOOR SPECIFICATIONS

- Door weight up to 250 lbs.
- Wood doors 1-3/4" thick (top-mount hangers)
- Door bottom 3/8" undercut
- Glass doors 3/8" to 1/2" thick



### 9433 PACKAGED SETS

#### Dual Wheel 2m SS Round Rail

##### FEATURES

Materials: 304 stainless steel track and hangers with nylon coated rollers

- System Includes:
- Stainless steel track (78" or 96") with two end caps - available in round or flat rail
  - Hangers with wall brackets
  - One door bottom guide
  - Two track stops
  - Mounting and installation hardware

Standards: Meets performance requirements of ANSI/BHMA 156.14 (Grade 1) for sliding doors by exceeding 100,000 cycles



##### DOOR SPECIFICATIONS

- Door weight up to 250 lbs.
- Wood doors 1-3/4" thick (top-mount hangers)
- Door bottom 3/8" undercut
- Glass doors 3/8" to 1/2" thick



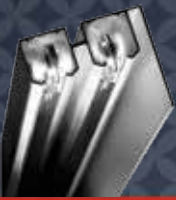

## 9400 SERIES BARN DOOR HARDWARE

### 9435 PACKAGED SETS

#### Top Mount Spoke Wheel 2m SS Round Rail

##### FEATURES

- Materials: 304 stainless steel track and hangers with nylon coated rollers
- System Includes:
- Stainless steel track (78" or 96") with two end caps - available in round or flat rail
  - Hangers with wall brackets
  - One door bottom guide
  - Two track stops
  - Mounting and installation hardware
- Standards: Meets performance requirements of ANSI/BHMA 156.14 (Grade 1) for sliding doors by exceeding 100,000 cycles



##### DOOR SPECIFICATIONS

- Door weight up to 250 lbs.
- Wood doors 1-3/4" thick (top-mount hangers)
- Door bottom 3/8" undercut
- Glass doors 3/8" to 1/2" thick

### 9436 PACKAGED SETS

#### Face Mount Stick 2m SS Round Rail

##### FEATURES

- Materials: 304 stainless steel track and hangers with nylon coated rollers
- System Includes:
- Stainless steel track (78" or 96") with two end caps - available in round or flat rail
  - Hangers with wall brackets
  - One door bottom guide
  - Two track stops
  - Mounting and installation hardware
- Standards: Meets performance requirements of ANSI/BHMA 156.14 (Grade 1) for sliding doors by exceeding 100,000 cycles



##### DOOR SPECIFICATIONS

- Door weight up to 250 lbs.
- Wood doors 1-1/4" to 1-3/8" thick
- Door bottom 3/8" undercut
- Glass doors 3/8" to 1/2" thick







## 9400 SERIES BARN DOOR HARDWARE

### 9437 PACKAGED SETS

#### Face Mount Dual Wheel 2m SS Round Rail

##### FEATURES

- Materials: 304 stainless steel track and hangers with nylon coated rollers
- System Includes:
- Stainless steel track (78" or 96") with two end caps - available in round or flat rail
  - Hangers with wall brackets
  - One door bottom guide
  - Two track stops
  - Mounting and installation hardware
- Standards: Meets performance requirements of ANSI/BHMA 156.14 (Grade 1) for sliding doors by exceeding 100,000 cycles



##### DOOR SPECIFICATIONS

- Door weight up to 250 lbs.
- Wood doors 1-1/4" - 1-3/8" thick
- Door bottom 3/8" undercut
- Glass doors 3/8" to 1/2" thick



### 9438 PACKAGED SETS

#### Face Mount Triangle 2m SS Round Rail

##### FEATURES

- Materials: 304 stainless steel track and hangers with nylon coated rollers
- System Includes:
- Stainless steel track (78" or 96") with two end caps - available in round or flat rail
  - Hangers with wall brackets
  - One door bottom guide
  - Two track stops
  - Mounting and installation hardware
- Standards: Meets performance requirements of ANSI/BHMA 156.14 (Grade 1) for sliding doors by exceeding 100,000 cycles



##### DOOR SPECIFICATIONS

- Door weight up to 250 lbs.
- Wood doors 1-1/4" - 1-3/8" thick
- Door bottom 3/8" undercut
- Glass doors 3/8" to 1/2" thick



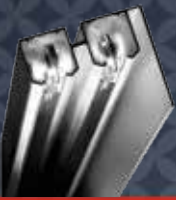

## 9400 SERIES BARN DOOR HARDWARE

### 9462 PACKAGED SET

#### Flat Stick Strap 2m SS Round Rail

##### FEATURES

Materials: 304 stainless steel track and hangers with nylon coated rollers

System Includes:

- Stainless steel track (72" or 96") with two end caps - available in round or flat rail
- Hangers with wall brackets
- One door bottom guide
- Two track stops
- Mounting and installation hardware

Standards: Meets performance requirements of ANSI/BHMA 156.14 (Grade 1) for sliding doors by exceeding 100,000 cycles

##### DOOR SPECIFICATIONS

- Door weight up to 250 lbs.
- Wood doors 1-3/8" thick
- Door bottom 3/8" undercut





## 9400 SERIES BARN DOOR HARDWARE - CONESTOGA SERIES

### FEATURES

- Durable powder-coated black rail and Conestoga Style, Barn Door Hangers
- Conforms to ANSI BHMA A156.14-2007
- Grade 1 for sliding doors by exceeding 100,000 cycles in operation

### SPECIFICATIONS

- Door weight up to 250 lbs.
- Wood doors up to 1-3/4" thick

### SLIDING BARN DOOR



Stock Number	Hager Part Number	Description
<b>Conestoga Barn Door</b>		
<b>Rail Only</b>		
186242	9450-48	48" Black Powder Coated, Flat Rail
186243	9450-72	72" Black Powder Coated, Flat Rail
186251	9450-96	96" Black Powder Coated, Flat Rail
<b>Hanger Kits Less Rail, All Kits Include two carriers, stops, floor guide and rail mounting brackets and fasteners</b>		
188467	9452	3" Black Powder Coated Hook Carrier Kit Less Rail
188468	9453	5" Black Powder Coated Hook Carrier Kit Less Rail
188469	9454	3" Black Powder Coated Strap Carrier Kit Less Rail
188470	9455	3" Black Powder Coated Top Mount Carrier Kit Less Rail
<b>Optional Components</b>		
<b>Privacy Latch and Pull</b>		
186296	1-269-8693	Sliding Door Privacy Latch & Strike Plate
186299	1-269-8694	4" x 1-3/4" x 7/16" Flush Pull
<b>Accessories</b>		
186289	1-269-8689	Bracket Kit: Includes 1 Wall Mount Bracket with Fastener
186290	1-269-8690	Stop Kit: Includes 2 End Stops with Fasteners
186292	1-269-8691	Splice Kit: Includes Splice Components and Fasteners for Joint Rails

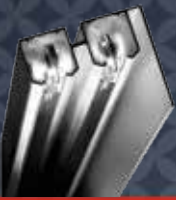

**9400 SERIES BARN DOOR HARDWARE - CONESTOGA SERIES - HOW TO ORDER**

**IMPORTANT:**

- 1.Track is ordered separately from hardware kit.
- 2.Track and Carrier Hardware are shipped in separate cartons.

**Example:**

**Single Door Solution:**

- 1) **9450 Track:** Specify length (48", 72" or 96").
- 2) **Carrier Hardware Kit:** Specify style – Includes all mounting hardware

- 9450 - 48
- 9450 - 72
- 9450 - 96

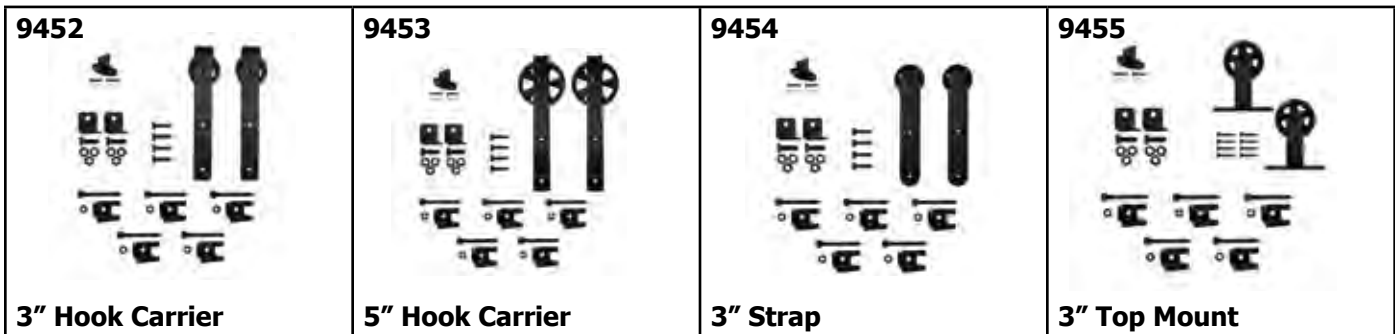

**Bi-Part Door Solution:**

If using two doors that are 3' wide, order a 6' track per door, for a total of 12'. This allows the doors to clear the door opening when in the open position. Order one carrier hardware kit per door and one Splice Kit.

**To Order:**

- 1) **9450 Track:** Specify quantity and length.
- 2) **Carrier Hardware Kit:** Specify quantity and carrier style. Example: Order 2 of part number 9453, 5" hook carrier style – Includes all mounting hardware.

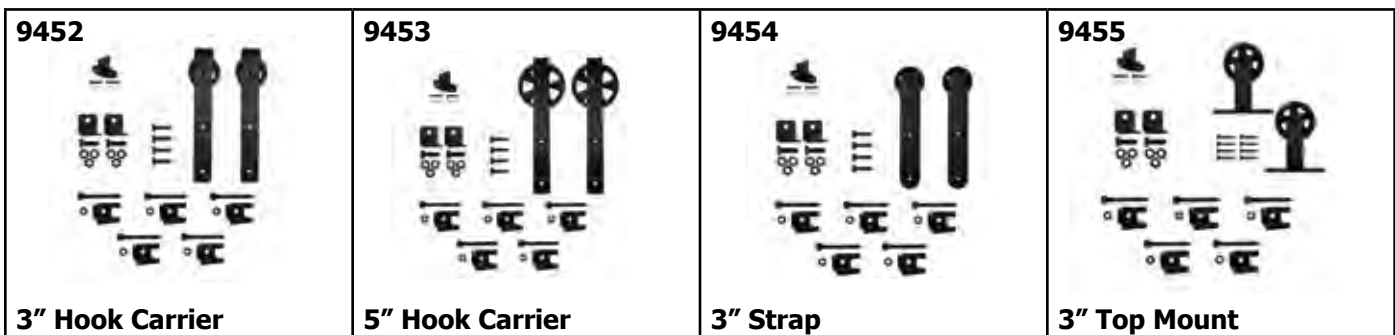

- 3) **Splice Kit:** Order 1 of part number 1-269-8691 Flat Rail Splice Kit.





## 9400 SERIES BARN DOOR HARDWARE - CONESTOGA SERIES

### 9450 Durable Black Powder-Coated Rail

#### FEATURES

Materials:	Durable powder-coated black aluminum
Available in:	48", 72" and 96" lengths



### 9452 3" Hook Carrier (Rail Not Included)

#### FEATURES

Materials:	Durable powder-coated black aluminum
System Includes:	<ul style="list-style-type: none"> <li>• Two carriers</li> <li>• Two stops</li> <li>• Floor guide</li> <li>• Rail mounting brackets and fasteners</li> </ul>
Standards:	Meets performance requirements of ANSI/BHMA 156.14 (Grade 1) for sliding doors by exceeding 100,000 cycles



#### DOOR SPECIFICATIONS

- Door weight up to 250 lbs.
- Wood doors up to 1-3/4" thick

### 9453 5" Hook Carrier (Rail Not Included)

#### FEATURES

Materials:	Durable powder-coated black aluminum
System Includes:	<ul style="list-style-type: none"> <li>• Two carriers</li> <li>• Two stops</li> <li>• Floor guide</li> <li>• Rail mounting brackets and fasteners</li> </ul>
Standards:	Meets performance requirements of ANSI/BHMA 156.14 (Grade 1) for sliding doors by exceeding 100,000 cycles



#### DOOR SPECIFICATIONS

- Door weight up to 250 lbs.
- Wood doors up to 1-3/4" thick

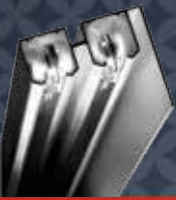

**9400 SERIES BARN DOOR HARDWARE - CONESTOGA SERIES**

**9454  
3" Strap Carrier (Rail Not Included)**

**FEATURES**

- |                  |  |
|------------------|--|
| Materials:       | Durable powder-coated black aluminum   |
| System Includes: | <ul style="list-style-type: none"> <li>• Two carriers</li> <li>• Two stops</li> <li>• Floor guide</li> <li>• Rail mounting brackets and fasteners</li> </ul> |
| Standards:       | Meets performance requirements of ANSI/BHMA 156.14 (Grade 1) for sliding doors by exceeding 100,000 cycles   |

**DOOR SPECIFICATIONS**

- Door weight up to 250 lbs.
- Wood doors up to 1-3/4" thick



**9455  
3" Top Mount Carrier (Rail Not Included)**

**FEATURES**

- |                  |  |
|------------------|--|
| Materials:       | Durable powder-coated black aluminum   |
| System Includes: | <ul style="list-style-type: none"> <li>• Two carriers</li> <li>• Two stops</li> <li>• Floor guide</li> <li>• Rail mounting brackets and fasteners</li> </ul> |
| Standards:       | Meets performance requirements of ANSI/BHMA 156.14 (Grade 1) for sliding doors by exceeding 100,000 cycles   |

**DOOR SPECIFICATIONS**

- Door weight up to 250 lbs.
- Wood doors up to 1-3/4" thick





**9400 SERIES BARN DOOR HARDWARE - CONESTOGA SERIES - OPTIONAL COMPONENTS**



**1-269-8689**  
Bracket Kit



**1-269-8693**  
Privacy Latch



**1-269-8690**  
Stop Kit



**1-269-8694**  
Flush Pull



**1-269-8691**  
Splice Kit





# Optional Components



## 330D

### Pocket Door Latch

**Certification:** Meets ANSI A156.14 for D0821.1

**Size:** 2-3/4" x 2-1/2"  
(70 mm x 64 mm)

**Finger Piece:** 1-3/8" (35 mm) extension

**Materials:** Brass

**Finishes:** US3, US5, US10B, US15, US15A, US19, US26, US26D

**Fasteners:** Two (2) #6 x 5/8" OPHWS; (2) #6 x 3/4" FPHWS

**Notes:** For use with 1-3/8" to 1-3/4" (35 mm to 45 mm) door



## 1741

### Full Mortise, Five Knuckle, Plain Bearing Hinge

- Steel with steel pin (ANSI A5134)
- Reversible
- Square corners
- Removable pin
- 3.5" x 3.5"
- US2D



## 330L

### Pocket Door Privacy Latch

**Size:** 2-3/4" x 2-1/2"  
(70 mm x 64 mm)

**Finger Piece:** 1-3/8" (35 mm) extension

**Strike Size:** 1" x 2-1/4" (25 mm x 57 mm)

**Materials:** Brass

**Finishes:** US3, US5, US10B, US15, US15A, US19, US26, US26D

**Fasteners:** Two (2) #6 x 5/8" OPHWS; (2) #6 x 3/4" FPHWS

**Notes:** For use with 1-3/8" door



## 2610

### Flush Cup Finger Pull

**Overall Diameter:** 31/32" (25 mm)

**Finger Pull Diameter:** 3/4" (19 mm)

**Depth:** 5/16" (8 mm)

**Projection:** 1/32" (.8 mm)

**Materials:** Solid brass

**Finishes:** US3, US4, US5, US10A, US15, US15A, US26, US26D, ABA

**Notes:**

Built-in prong design eliminates the need for screws or brads



## 330M

### Pocket Door Privacy Latch

**Certifications:** Meets ANSI A156.14 for D0831

**Size:** 2-3/4" x 2-1/2"  
(70 mm x 64 mm)

**Finger Piece:** 1-3/8" (35 mm) extension

**Strike Size:** 1" x 2-1/4" (25 mm x 57 mm)

**Materials:** Brass

**Finishes:** US3, US5, US10B, US15, US15A, US19, US26, US26D

**Fasteners:** Two (2) #6 x 5/8" OPHWS; (2) #6 x 3/4" FPHWS

**Notes:** For use with 1-3/4" door



## 2630

### Flush Cup Pull

**Overall Diameter:** 2-7/16" (62 mm)

**Finger Pull:** 2-1/16" (52 mm) diameter

**Depth:** 11/32" (9 mm)

**Projection:** 3/32" (2 mm)

**Materials:** Solid brass

**Finishes:** US3, US4, US5, US10A, US15, US15A, US26, US26D, ABA

**Notes:**

Built-in prong design eliminates the need for screws or brads.



## 9111

### Fixed Bottom Door Guide

**Materials:** Zinc plated steel with bronze roller

**Guide:** 2" x 3/4" x 3/32"  
(51 mm x 19 mm x 2.4 mm)

**Roller:** 1-7/32" x 1/2"  
(14 mm x 13 mm)

**Notes:**

- Door mortising is not required
- Use with 9122 guide channel

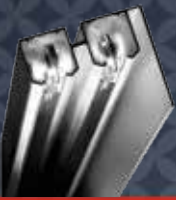

## OPTIONAL COMPONENTS



### 9113

#### Stop

Materials: Zinc plated steel and rubber  
 Stop: 1-5/8" x 1-1/2" x 5/8" x  
 1-3/4" (41 mm x 38 mm x  
 16 mm x 45 mm)

Notes: Use with 9105 hanger



### 9114

#### Bottom Guide Rail

Materials: Aluminum  
 Guide: 7/8" x 1/2" (22 mm x 13 mm)  
 Lengths: 72" (1829 mm)  
 96" (2438 mm)  
 144" (3658 mm)

Notes:
 

- Door bottom prep requires 1/4" (6 mm) wide kerf and 9/16" (14 mm) depth
- Pre-punched for use with flat head screws



### 9121

#### Adjustable Bottom Door Guide

Materials: Zinc plated steel with bronze roller  
 Guide: 1" x 3-1/2" x 3/16"  
 (25 mm x 89 mm x 5 mm)

Post: 2-1/2" x 5/16" (64 mm x 8 mm)

Notes: Use with 9122 guide channel



### 9122

#### Bottom Guide Channel

Materials: Extruded aluminum  
 Gauge: 0.093 (2.4 mm)  
 Lengths: 48" (1219 mm) to 192"  
 (4877 mm)  
 Channel: 5/8" x 3/4"  
 (16 mm x 19 mm)

Notes:
 

- Screws not provided
- Mortised into floor or surface mounted



### 9169

#### Top Pivot Assembly

Materials: Zinc plated steel  
 Top Pivot: 1" x 3-1/2" x 1-7/16"  
 (25 mm x 89 mm x 37 mm)

Notes: Inserts into 9155 top pivot clamp assembly



### 9200\* | 9201\*\*

#### Single Wheel Hanger

Materials: Zinc plated steel with molded Celcon wheels

Gauge: 0.075" (2 mm)

Wheel: 7/8" (22 mm) diameter

Notes:
 

- For use on doors weighing up to 60 lbs (27 kg)
- For use with 9810, 9820, and 9840 track
- Side mounted with slot adjust offset
- Hanger is stamped "A" or "B" for easy identification

 \* 9200 is A offset of 3/8" (9.5 mm)  
 \*\* 9201 is B offset of 11/16" (17.5 mm)



### 9202\* | 9203\*\*

#### Two Wheel Hanger

Materials: Zinc plated steel with molded Celcon wheels

Gauge: 0.075" (2 mm)

Wheel: 7/8" (22 mm) diameter

Notes:
 

- For use on doors weighing up to 75 lbs (34 kg)
- For use with 9810, 9820, and 9840 track
- Side mounted with slot adjust offset
- Hanger is stamped "A" or "B" for easy identification

 \* 9202 is B offset of 11/16" (17.5 mm)  
 \*\* 9203 is A offset of 3/8" (9.5 mm)



### 9220

#### Bi-Fold Door Hinge

Materials: Steel with bright zinc finish  
 Hinge: 3" x 1" (76 mm x 25 mm) hole

Hole Locations: 1/2" (13 mm) from the center lines of holes to center of barrel

Notes: Non-mortise and easy to install





## OPTIONAL COMPONENTS



### 9262

#### Pocket Door Keyed Lock

- Materials: Steel
- Notes:
- For doors 1-3/8" (35 mm) to 1-3/4" (44 mm) thick
  - Lock cylinder fits in one 1" (25 mm) hole
  - Available keyed alike



### 9264

#### Keyed Lock

- Materials: Steel
- Notes:
- Lock cylinder fits 1" (25 mm) hole
  - Available keyed alike



### 9351

#### Guide

- Materials: High density polyethylene
- Guide: 4-9/16" x 1" x 11-3/16" (116 mm x 25 mm x 46 mm)
- Notes: One piece fixed guide for 1-3/8" (35 mm) doors



### 9353

#### Adjustable Door Guide

- Materials: High density polyethylene
- Notes: Adjustable guide from 3/4" (19 mm) to 1-3/8" (35 mm)



### 9354

#### 3/4" (19 mm) Riser

- Materials: Steel with bright zinc finish
- Rise: 3/4" (19 mm)
- Notes: For mounting 9351 and 9353 floor guides over carpeting



### 9558

#### Wood Knob

- Diameter: 1-1/2" (38 mm)
- Materials: Solid wood
- Notes: Will accept paint or stain



### 9559

#### Aligner

- Materials: Steel with brass-tone dichromate finish
- Notes:
- Keeps lead doors aligned when closed
  - Use one on each lead door



### 9572

#### 4-Wheel Hanger and Door Bracket

- For 100 lbs (45 kg) doors
- Materials: Steel with bright zinc
- Wheel: 7/8" (22 mm) diameter
- Notes:
- Wheels are self aligning to allow consistent contact with track
  - Pre-lubricated Celcon wheels
  - Includes wrench
  - For use on doors weighing up to 100 lbs (45 kg) per door
  - For use with 9601, 9602, and 9603 track



### 9575

#### Parts Bag

- Includes four (4) 9572 hangers with quick release top mount plate, one (1) 9909 guide
- Note: Up to 125 lbs (57 kg) per door



### 9605

#### 4-Wheel Hanger with Top Mount Plate

- Materials: Steel with brass-tone dichromate finish
- Wheels: 7/8" (22 mm) diameter
- Notes:
- Self aligning to allow consistent contact with track
  - Pre-lubricated Celcon wheels mounted on steel ball bearing shafts
  - Can be used on pivot set
  - Up to 125 lbs (57 kg) per door
  - Use in conjunction with 9601, 9602, or 9603 track



### 9606

#### 4-Wheel Ball Bearing Hanger with Top Mount Plate

- Materials: Steel with brass-tone dichromate finish
- Wheels: 7/8" (22 mm) diameter
- Notes:
- Self aligning to allow consistent contact with track
  - Pre-lubricated Celcon wheels mounted on steel ball bearing shafts
  - Up to 150 lbs (68 kg) per door
  - Use with 9601, 9602, or 9603 track

## OPTIONAL COMPONENTS



### 9610

#### Replacement Top Mount Plate

Materials: Bright zinc plated steel  
 Gauge: 1/8" (3 mm)  
 Size: 1-3/8" (35 mm) x 2-13/16" (72 mm)

Notes:
 

- Replacement for four wheel hangers 9605, 9606, 9575, 9824, 9825 and 9827



### 9634

#### Pocket Door Adapter Kit

Materials: Galvanized steel and wood shims

Clearance: 1/8" (3 mm) on each side of a 1-3/4" (44 mm) door

Notes:
 

- Used with 1-3/4" (44 mm) doors by allowing additional clearance between door and jamb
- Includes wider floor plates and shims for spacing split studs for an additional 3/16" (4.8 mm) on each side of a 1-3/4" (44 mm) door



### 9639

#### Double Pocket Door Adapter Kit

Materials: Zinc plated steel and rubber bumper stops

Notes:
 

- Joins two frames in the middle of the doorway
- For joining 9629, 9630, 9631 or 9850 pocket door kits
- Fits both KD and Built Up frames
- Lag bolt for attaching to rough header
- Bumpers included to stop doors in center of doorway



### 9680

#### Parts Bag

Includes four (4) 9606 ball bearing hangers and one (1) 9909 guide  
 Note: Up to 150 lbs (68 kg) per door



### 9709

#### Aluminum Fascia

Materials: Extruded aluminum  
 Gauge: 0.062" (1.6 mm)  
 Lip: 5/8" (16 mm)  
 Fascia: 2-3/4" (70 mm)  
 Lengths: 48" (1219 mm) to 144" (3658 mm)

Notes:
 

- **Grooved fascia for painting**
- Pre-punched holes for easy installation



### 9815

#### Bumper Stop

Materials: Zinc plated steel and rubber

Notes:
 

- Fits all Hager track styles except 9101
- Screws onto track
- Included in bi-fold sets 9570 and 9890



### 9865

#### Flush Cup Pull

Overall Diameter: 1-31/32" (50 mm)  
 Finger Pull Diameter: 1-19/32" (41 mm)  
 Depth: 11/32" (9 mm)  
 Projection: 5/64" (2 mm)  
 Materials: Tan color ABS plastic

Notes:
 

- Built-in prong design eliminates the need for screws or brads



### 9877

#### Door Guide

Materials: Plastic

Notes:
 

- For doors 1-3/8" (35 mm) to 1-3/4" (44 mm) thick
- Two pieces required per door



### 9880

#### Door Stop

Materials: Zinc plated steel and rubber  
 Gauge: 0.090" (2.3 mm)  
 Stop: 1-1/4" x 1-1/4" x 7/8" (32 mm x 32 mm x 22 mm)

Notes:
 

- For doors up to 175 lbs (79 kg)
- Keeps rear door pull exposed
- Mounts on door
- Not included in sets





## OPTIONAL COMPONENTS



### 9881 Bumper

Materials: Rubber  
 Stop: 1/2" diameter x 3/8" deep  
 (13 mm x 10 mm)  
 Notes: With screws



### 9928

#### Reversible Side Mount Bracket

Materials: Steel with bright zinc  
 Posts: Molded Celcon/Nylon  
 Gauge: 0.060" (1.5 mm)  
 Guide: 4-7/8" x 1-5/8" x 1-3/16"  
 (124 mm x 41 mm x 30 mm)  
 Size: For 3/4" to 1-3/4"  
 (19 mm to 44 mm) doors  
 Notes:
 

- Mounts at ends of track and every foot



### 9883

#### Two Piece Pocket Door Guide

Materials: Polyethylene  
 Guide: 1-3/16" x 3/4" x 1-1/8"  
 (21 mm x 19 mm x 29 mm)  
 Notes:
 

- Two pieces per door required
- Screws to jamb to guide door and prevent rubbing



### 3835

#### Small Case Deadlock

Thumbturn: Meet ADA Requirements, "No pinch," No grasp."  
 Lock Case: Heavy wrought steel with zinc dichromate finish - 4-5/16" x 3-9/16" x 1" (110 mm x 90 mm x 25 mm)  
 Armor Front: 1-1/4" x 5-5/8" x 7/32" (32 mm x 143 mm x 5 mm)  
 Keys: Two operating keys supplied per lock  
 Cylinder:
 

- Brass - keyed different - C keyway - Standard
- Other keying options, including keyed 6-pin, available from factory
- SFIC uncombined or combined, brass 6- or 7-pin sold separately
- Drilled 6-pin, keyed 5-pin - Standard
- Small Format Interchangeable Core housing available
- Schlage "L" cam - Standard

 Door Thickness:
 

- 1-3/8" - 2-1/2" (35 mm-64 mm) - steel door
- 1-3/4" - 2-1/2" (45 mm-64 mm)- wood door
- Must specify door thickness if greater than 1-3/4" (45 mm)

 Backset: 2-3/4" (70 mm) only  
 Deadbolt: 1" (25 mm) throw - stainless steel  
 Strike:
 

- 1 1/8" wide x 3 1/2" (29 mm x 89 mm) NO LIP

 Finishes: US26D  
 Functions: 35-Cylinder x Thumbturn, 36-Single Cylinder, 37-Double Cylinder, 38-Thumbturn Only, 39-Thumbturn w/ Emergency Key



### 9884

#### Pocket Door Edge Pull

Finger Pull Extends: 1-1/16" (27 mm)  
 Faceplate: 21/32" x 3-1/2" (17 mm x 89 mm)  
 Materials: Die cast zinc  
 Finishes: US3  
 Fasteners: Two (2) #6 x 5/8" FPHWS  
 Notes: Ideal for narrow and standard door thicknesses.



### 9889

#### Non-Adjustable Floor Guide

Materials: Polyethylene  
 Guide: 2-3/8" x 2-1/2" x 7/8"  
 (60 mm x 64 mm x 22 mm)  
 Notes: For 1-3/8" (35 mm) doors



### 9909

#### Adjustable Guide

Materials: Steel with bright zinc  
 Posts: Molded Celcon/Nylon  
 Gauge: 0.060" (2 mm)  
 Guide: 4-7/8" x 1-5/8" x 1-3/16"  
 (124 mm x 41 mm x 30 mm)  
 Notes: For doors 3/4" to 1-3/4" (19 mm to 44 mm) thick with steel base, celcon, and nylon posts



**One Family. One Brand. One Vision.™**

[www.hagerco.com](http://www.hagerco.com)

# INDEX

Part Number	Section	Page
1	Trim & Auxiliary	5
2	Trim & Auxiliary	5
3	Trim & Auxiliary	5
4	Trim & Auxiliary	6
5D	Trim & Auxiliary	7
5N	Trim & Auxiliary	7
6N	Trim & Auxiliary	7
7N	Trim & Auxiliary	8
8N	Trim & Auxiliary	8
9	Trim & Auxiliary	9
10	Trim & Auxiliary	9
11	Trim & Auxiliary	9
12	Trim & Auxiliary	10
13	Trim & Auxiliary	10
14	Trim & Auxiliary	10
15C	Trim & Auxiliary	22
15N	Trim & Auxiliary	22
15P	Trim & Auxiliary	22
15S	Trim & Auxiliary	22
16N	Trim & Auxiliary	23
16R	Trim & Auxiliary	23
17N	Trim & Auxiliary	23
19N	Trim & Auxiliary	11
20	Trim & Auxiliary	11
20N	Trim & Auxiliary	11
21	Trim & Auxiliary	11
22	Trim & Auxiliary	12
22N	Trim & Auxiliary	71
23Q	Trim & Auxiliary	12
24Q	Trim & Auxiliary	12
25B	Trim & Auxiliary	23
25C	Trim & Auxiliary	24
25N	Trim & Auxiliary	24
25P	Trim & Auxiliary	24
26N	Trim & Auxiliary	24
27N	Trim & Auxiliary	25
27P	Trim & Auxiliary	25
29KS	Electrified Solutions	24
30, 40, 50 Series	Trim & Auxiliary	26
30S	Trim & Auxiliary	28
40R	Trim & Auxiliary	28
45BE	Exit Devices	21
45CE	Exit Devices	21
45DT	Exit Devices	21
45ET	Exit Devices	21
45MB	Exit Devices	24

Part Number	Section	Page
45MC	Exit Devices	24
45MD	Exit Devices	24
45MN	Exit Devices	24
45NL	Exit Devices	21
45PD	Exit Devices	26
45PN	Exit Devices	26
45PT	Exit Devices	26
46BE	Exit Devices	40
46CE	Exit Devices	40
46DT	Exit Devices	40
45NK	Exit Devices	40
46NL	Exit Devices	40
47BE	Exit Devices	50
47BT	Exit Devices	54
47CE	Exit Devices	50
47DT	Exit Devices	50
47KD	Exit Devices	52
47KE	Exit Devices	52
47KN	Exit Devices	52
47KP	Exit Devices	52
47NL	Exit Devices	50
47PD	Exit Devices	54
47PN	Exit Devices	54
47PT	Exit Devices	54
47RD	Exit Devices	55
47RN	Exit Devices	55
50T	Trim & Auxiliary	28
60S	Trim & Auxiliary	29
70S	Trim & Auxiliary	29t
80, 90, 100 Series	Trim & Auxiliary	26
80S	Trim & Auxiliary	29
90R	Trim & Auxiliary	30
100	Commercial Hinges	45
100T	Trim & Auxiliary	30
110S	Trim & Auxiliary	30
120L	Trim & Auxiliary	31
121L	Trim & Auxiliary	31
122L	Trim & Auxiliary	31
125S	Trim & Auxiliary	32
126S	Trim & Auxiliary	32
127S	Trim & Auxiliary	32
128P	Trim & Auxiliary	32
128S	Trim & Auxiliary	33
129P	Trim & Auxiliary	33
130S	Trim & Auxiliary	33
131S	Trim & Auxiliary	33

## INDEX

Part Number	Section	Page
133S	Trim & Auxiliary	34
134S	Trim & Auxiliary	34
136S	Trim & Auxiliary	34
137S	Trim & Auxiliary	34
138P	Trim & Auxiliary	35
139P	Trim & Auxiliary	35
140P	Trim & Auxiliary	35
150B	Trim & Auxiliary	35
150D	Trim & Auxiliary	35
150V	Trim & Auxiliary	35
151B	Trim & Auxiliary	36
151D	Trim & Auxiliary	36
151V	Trim & Auxiliary	36
152B	Trim & Auxiliary	36
152D	Trim & Auxiliary	36
152V	Trim & Auxiliary	36
153B	Trim & Auxiliary	36
153D	Trim & Auxiliary	36
153V	Trim & Auxiliary	36
154B	Trim & Auxiliary	36
154D	Trim & Auxiliary	36
154V	Trim & Auxiliary	36
155B	Trim & Auxiliary	37
155D	Trim & Auxiliary	37
155V	Trim & Auxiliary	37
156B	Trim & Auxiliary	37
156D	Trim & Auxiliary	37
156V	Trim & Auxiliary	37
157B	Trim & Auxiliary	37
157D	Trim & Auxiliary	37
157V	Trim & Auxiliary	37
158B	Trim & Auxiliary	37
158D	Trim & Auxiliary	37
158V	Trim & Auxiliary	37
159B	Trim & Auxiliary	38
159D	Trim & Auxiliary	38
159V	Trim & Auxiliary	38
160B	Trim & Auxiliary	38
160D	Trim & Auxiliary	38
160V	Trim & Auxiliary	38
161B	Trim & Auxiliary	38
161D	Trim & Auxiliary	38
161V	Trim & Auxiliary	38
164B	Trim & Auxiliary	38
164D	Trim & Auxiliary	38
164V	Trim & Auxiliary	38

Part Number	Section	Page
165B	Trim & Auxiliary	39
165D	Trim & Auxiliary	39
165V	Trim & Auxiliary	39
167B	Trim & Auxiliary	39
167D	Trim & Auxiliary	39
167V	Trim & Auxiliary	39
170D	Trim & Auxiliary	39
180H	Trim & Auxiliary	40
180K	Trim & Auxiliary	40
180M	Trim & Auxiliary	40
180P	Trim & Auxiliary	40
180Q	Trim & Auxiliary	40
181H	Trim & Auxiliary	40
181K	Trim & Auxiliary	40
181M	Trim & Auxiliary	40
181P	Trim & Auxiliary	40
181Q	Trim & Auxiliary	40
182H	Trim & Auxiliary	41
182K	Trim & Auxiliary	41
182M	Trim & Auxiliary	41
182P	Trim & Auxiliary	41
182Q	Trim & Auxiliary	41
185G	Trim & Auxiliary	41
190S	Trim & Auxiliary	42
193S	Trim & Auxiliary	42
194S	Trim & Auxiliary	42
198S	Trim & Auxiliary	42
199B	Trim & Auxiliary	42
204S	Trim & Auxiliary	42
208	Trim & Auxiliary	85
209	Trim & Auxiliary	85
210	Trim & Auxiliary	85
211	Trim & Auxiliary	86
212	Trim & Auxiliary	86
214S	Trim & Auxiliary	42
220S	Trim & Auxiliary	42
223S	Trim & Auxiliary	42
224S	Trim & Auxiliary	42
225S	Trim & Auxiliary	42
230W	Trim & Auxiliary	43
232W	Trim & Auxiliary	43
234W	Trim & Auxiliary	43
236W	Trim & Auxiliary	43
241F	Trim & Auxiliary	49
242F	Trim & Auxiliary	49
243F	Trim & Auxiliary	49



## INDEX

Part Number	Section	Page
244F	Trim & Auxiliary	49
245F	Trim & Auxiliary	50
246B	Trim & Auxiliary	50
248F	Trim & Auxiliary	50
248G	Trim & Auxiliary	50
249F	Trim & Auxiliary	50
250W	Trim & Auxiliary	44
251	Commercial Hinges	40
251W	Trim & Auxiliary	44
252	Commercial Hinges	40
252F	Trim & Auxiliary	51
253	Commercial Hinges	40
254	Commercial Hinges	40
254S	Trim & Auxiliary	44
254W	Trim & Auxiliary	44
255S	Trim & Auxiliary	45
255W	Trim & Auxiliary	45
256S	Trim & Auxiliary	45
256W	Trim & Auxiliary	46
257F	Trim & Auxiliary	51
258F	Trim & Auxiliary	51
259F	Trim & Auxiliary	52
259H	Trim & Auxiliary	52
260W	Trim & Auxiliary	46
263	Commercial Hinges	45
265	Commercial Hinges	45
267F	Trim & Auxiliary	52
267S	Trim & Auxiliary	52
268F	Trim & Auxiliary	53
268S	Trim & Auxiliary	53
269F	Trim & Auxiliary	53
269T	Trim & Auxiliary	54
270C	Trim & Auxiliary	56
270CR	Trim & Auxiliary	56
270D	Trim & Auxiliary	56
270R	Trim & Auxiliary	56
271D	Trim & Auxiliary	56
271W	Trim & Auxiliary	48
272W	Trim & Auxiliary	48
273W	Trim & Auxiliary	48
274B	Trim & Auxiliary	81
274C	Trim & Auxiliary	81
274D	Trim & Auxiliary	81
275D	Trim & Auxiliary	57
276D	Trim & Auxiliary	57
277D	Trim & Auxiliary	81

Part Number	Section	Page
278D	Trim & Auxiliary	57
279D	Trim & Auxiliary	57
280X	Trim & Auxiliary	58
281D	Trim & Auxiliary	58
282D	Trim & Auxiliary	58
283D	Trim & Auxiliary	59
291D	Trim & Auxiliary	59
292D	Trim & Auxiliary	60
293D	Trim & Auxiliary	60
294D	Trim & Auxiliary	61
295M	Trim & Auxiliary	61
295W	Trim & Auxiliary	62
296W	Trim & Auxiliary	62
297C	Trim & Auxiliary	63
297D	Trim & Auxiliary	63
297F	Trim & Auxiliary	64
297M	Trim & Auxiliary	64
297N	Trim & Auxiliary	64
298D	Trim & Auxiliary	64
300D	Trim & Auxiliary	81
301D	Trim & Auxiliary	82
303W	Trim & Auxiliary	82
305	Commercial Hinges	45
305D	Trim & Auxiliary	82
307D	Trim & Auxiliary	82
308D	Trim & Auxiliary	82
310C	Trim & Auxiliary	83
311H	Trim & Auxiliary	65
311L	Trim & Auxiliary	65
313L	Trim & Auxiliary	27
313S	Exit Devices	26
313S	Trim & Auxiliary	27
318D	Trim & Auxiliary	65
318S	Trim & Auxiliary	66
320R	Trim & Auxiliary	66
321R	Trim & Auxiliary	66
322V	Trim & Auxiliary	83
323S	Trim & Auxiliary	66
324W	Trim & Auxiliary	46
326F	Trim & Auxiliary	54
326W	Trim & Auxiliary	47
327F	Trim & Auxiliary	54
327W	Trim & Auxiliary	47
328F	Trim & Auxiliary	55
329F	Trim & Auxiliary	55
330D	Trim & Auxiliary	71

# INDEX

Part Number	Section	Page
330D	Sliding Door Hardware	40, 59
330L	Trim & Auxiliary	71
330L	Sliding Door Hardware	40, 59
330M	Trim & Auxiliary	71
330M	Sliding Door Hardware	40, 59
336A	Trim & Auxiliary	74
336B	Trim & Auxiliary	74
336C	Trim & Auxiliary	74
336D	Trim & Auxiliary	74
336E	Trim & Auxiliary	74
336F	Trim & Auxiliary	74
336G	Trim & Auxiliary	74
336H	Trim & Auxiliary	74
336J	Trim & Auxiliary	74
336K	Trim & Auxiliary	74
336L	Trim & Auxiliary	74
336M	Trim & Auxiliary	75
336N	Trim & Auxiliary	75
336P	Trim & Auxiliary	75
336Q	Trim & Auxiliary	75
336R	Trim & Auxiliary	75
337A	Trim & Auxiliary	75
337B	Trim & Auxiliary	75
337C	Trim & Auxiliary	75
337D	Trim & Auxiliary	75
340D	Trim & Auxiliary	67
341D	Trim & Auxiliary	67
342D	Trim & Auxiliary	67
345D	Trim & Auxiliary	67
350H	Trim & Auxiliary	76
350L	Trim & Auxiliary	76
350M	Trim & Auxiliary	76
350R	Trim & Auxiliary	76
350W	Trim & Auxiliary	76
351H	Trim & Auxiliary	76
351L	Trim & Auxiliary	76
352M	Trim & Auxiliary	77
352W	Trim & Auxiliary	77
354A	Trim & Auxiliary	77
354B	Trim & Auxiliary	77
360M	Trim & Auxiliary	77
360W	Trim & Auxiliary	77
361H	Trim & Auxiliary	77
361L	Trim & Auxiliary	77
362H	Trim & Auxiliary	78

Part Number	Section	Page
362L	Trim & Auxiliary	78
364L	Trim & Auxiliary	78
364M	Trim & Auxiliary	78
364N	Trim & Auxiliary	78
364S	Trim & Auxiliary	78
365M	Trim & Auxiliary	78
365W	Trim & Auxiliary	78
366R	Trim & Auxiliary	79
366S	Trim & Auxiliary	79
368E	Trim & Auxiliary	79
368M	Trim & Auxiliary	79
368U	Trim & Auxiliary	80
368W	Trim & Auxiliary	79
369L	Trim & Auxiliary	80
369R	Trim & Auxiliary	80
370M	Trim & Auxiliary	80
370U	Trim & Auxiliary	80
370W	Trim & Auxiliary	80
380 Series	Door Controls	38
380F	Door Controls	38
380G	Door Controls	38
380H	Door Controls	38
380R	Door Controls	38
380S	Door Controls	38
381A	Door Controls	39
381B	Door Controls	39
381C	Door Controls	39
381D	Door Controls	39
381E	Door Controls	39
381H	Door Controls	39
381S	Door Controls	39
381W	Door Controls	39
400S	Thresholds & Weatherstripping	11
401S	Thresholds & Weatherstripping	6
402S	Thresholds & Weatherstripping	6
403S	Thresholds & Weatherstripping	6
404S	Thresholds & Weatherstripping	6
406S	Thresholds & Weatherstripping	9
407S	Thresholds & Weatherstripping	9
408S	Thresholds & Weatherstripping	11
410S	Thresholds & Weatherstripping	6
411S	Thresholds & Weatherstripping	6
412S	Thresholds & Weatherstripping	6
413S	Thresholds & Weatherstripping	6
414S	Thresholds & Weatherstripping	6
415S	Thresholds & Weatherstripping	6

# INDEX

Part Number	Section	Page
416S	Thresholds & Weatherstripping	7
417	Commercial Hinges	45
417S	Thresholds & Weatherstripping	7
418S	Thresholds & Weatherstripping	7
419S	Thresholds & Weatherstripping	11
420S	Thresholds & Weatherstripping	8
421S	Thresholds & Weatherstripping	8
422S	Thresholds & Weatherstripping	8
423S	Thresholds & Weatherstripping	8
424S	Thresholds & Weatherstripping	8
426S	Thresholds & Weatherstripping	7
427S	Thresholds & Weatherstripping	7
428S	Thresholds & Weatherstripping	7
430	Commercial Hinges	21
430S	Thresholds & Weatherstripping	7
431S	Thresholds & Weatherstripping	9
432S	Thresholds & Weatherstripping	9
433S	Thresholds & Weatherstripping	9
434S	Thresholds & Weatherstripping	12
435S	Thresholds & Weatherstripping	12
436S	Thresholds & Weatherstripping	7
438S	Thresholds & Weatherstripping	9
440S	Thresholds & Weatherstripping	13
442S	Thresholds & Weatherstripping	12
443S	Thresholds & Weatherstripping	12
444S	Thresholds & Weatherstripping	12
445S	Thresholds & Weatherstripping	13
448S	Thresholds & Weatherstripping	7
450S	Thresholds & Weatherstripping	13
451	Commercial Hinges	43
451S	Thresholds & Weatherstripping	8
452	Commercial Hinges	43
452S	Thresholds & Weatherstripping	8
453	Commercial Hinges	43
454	Commercial Hinges	43
455	Commercial Hinges	43
455S	Thresholds & Weatherstripping	13
456	Commercial Hinges	43
457	Commercial Hinges	43
458	Commercial Hinges	43
460S	Thresholds & Weatherstripping	13
465S	Thresholds & Weatherstripping	13
470S	Thresholds & Weatherstripping	13
477S	Thresholds & Weatherstripping	12
478S	Thresholds & Weatherstripping	12
480S	Thresholds & Weatherstripping	10

Part Number	Section	Page
481S	Thresholds & Weatherstripping	10
484S	Thresholds & Weatherstripping	10, 13
492S	Thresholds & Weatherstripping	7
495	Commercial Hinges	40
496	Commercial Hinges	40
497	Commercial Hinges	40
500	Commercial Hinges	41
500-048	Roton Continuous Geared Hinges	16
500-200	Roton Continuous Geared Hinges	17
500-220	Roton Continuous Geared Hinges	18
503S	Thresholds & Weatherstripping	11
504S	Thresholds & Weatherstripping	11
505S	Thresholds & Weatherstripping	11
506S	Thresholds & Weatherstripping	11
508S	Thresholds & Weatherstripping	11
510	Commercial Hinges	42
511	Commercial Hinges	42
512	Commercial Hinges	42
515S	Thresholds & Weatherstripping	15
516S	Thresholds & Weatherstripping	15
517S	Thresholds & Weatherstripping	15
518S	Thresholds & Weatherstripping	15
520S	Thresholds & Weatherstripping	14
532S	Thresholds & Weatherstripping	14
541S	Thresholds & Weatherstripping	14
550	Commercial Hinges	41
551	Commercial Hinges	41
552S	Thresholds & Weatherstripping	14
560S	Thresholds & Weatherstripping	14
565S	Thresholds & Weatherstripping	14
572S	Thresholds & Weatherstripping	9
575S	Thresholds & Weatherstripping	15
580S	Thresholds & Weatherstripping	15
599S	Thresholds & Weatherstripping	15
600	Commercial Hinges	42
600S	Thresholds & Weatherstripping	16
603S	Thresholds & Weatherstripping	16
604S	Thresholds & Weatherstripping	16
608S	Thresholds & Weatherstripping	16
610	Commercial Hinges	42
611	Commercial Hinges	42
612	Commercial Hinges	42
615	Commercial Hinges	41
619S	Thresholds & Weatherstripping	19
621S	Thresholds & Weatherstripping	17
622S	Thresholds & Weatherstripping	17

## INDEX

Part Number	Section	Page
626S	Thresholds & Weatherstripping	17
627S	Thresholds & Weatherstripping	17
651S	Thresholds & Weatherstripping	18
652S	Thresholds & Weatherstripping	18
653S	Thresholds & Weatherstripping	18
654S	Thresholds & Weatherstripping	18
655S	Thresholds & Weatherstripping	18
676S	Thresholds & Weatherstripping	19
677S	Thresholds & Weatherstripping	19
700	Commercial Hinges	13
701S	Thresholds & Weatherstripping	16
717S	Thresholds & Weatherstripping	20
718S	Thresholds & Weatherstripping	20
719	Thresholds & Weatherstripping	21
720	Thresholds & Weatherstripping	21
721	Thresholds & Weatherstripping	22
722	Thresholds & Weatherstripping	21
724	Thresholds & Weatherstripping	21
725	Thresholds & Weatherstripping	22
726	Thresholds & Weatherstripping	22
727	Thresholds & Weatherstripping	22
728	Thresholds & Weatherstripping	22
729	Thresholds & Weatherstripping	21
730S	Thresholds & Weatherstripping	25
734	Thresholds & Weatherstripping	21
736	Thresholds & Weatherstripping	22
737	Thresholds & Weatherstripping	22
738	Thresholds & Weatherstripping	22
740S	Thresholds & Weatherstripping	25
742S	Thresholds & Weatherstripping	25
743S	Thresholds & Weatherstripping	25
747S	Thresholds & Weatherstripping	25
750S	Thresholds & Weatherstripping	26
750-134	Roton Continuous Geared Hinges	19
750-138	Roton Continuous Geared Hinges	20
751S	Thresholds & Weatherstripping	23
752S	Thresholds & Weatherstripping	26
753S	Thresholds & Weatherstripping	26
754S	Thresholds & Weatherstripping	26
756S	Thresholds & Weatherstripping	26, 35
759S	Thresholds & Weatherstripping	27
770S	Thresholds & Weatherstripping	20, 27
771S	Thresholds & Weatherstripping	35
772S	Thresholds & Weatherstripping	23, 35
774S	Thresholds & Weatherstripping	23, 35
776S	Thresholds & Weatherstripping	23, 36

Part Number	Section	Page
777S	Thresholds & Weatherstripping	23
778S	Thresholds & Weatherstripping	23
779S	Thresholds & Weatherstripping	24
780S	Thresholds & Weatherstripping	24
780-041HD	Roton Continuous Geared Hinges	21
780-041LL	Roton Continuous Geared Hinges	21
780-045HD	Roton Continuous Geared Hinges	36
780-046HD	Roton Continuous Geared Hinges	37
780-053	Roton Continuous Geared Hinges	38
780-053HD	Roton Continuous Geared Hinges	38
780-054HD	Roton Continuous Geared Hinges	39
780-057HD	Roton Continuous Geared Hinges	32
780-110HD	Roton Continuous Geared Hinges	22
780-111	Roton Continuous Geared Hinges	23
780-111HD	Roton Continuous Geared Hinges	23
780-111LL	Roton Continuous Geared Hinges	23
780-112	Roton Continuous Geared Hinges	24
780-112HD	Roton Continuous Geared Hinges	24
780-112LL	Roton Continuous Geared Hinges	24
780-113HD	Roton Continuous Geared Hinges	25
780-114HD	Roton Continuous Geared Hinges	26
780-124HD	Roton Continuous Geared Hinges	27
780-124LL	Roton Continuous Geared Hinges	27
780-155HD	Roton Continuous Geared Hinges	40
780-157	Roton Continuous Geared Hinges	33
780-157HD	Roton Continuous Geared Hinges	33
780-208HD	Roton Continuous Geared Hinges	28
780-210	Roton Continuous Geared Hinges	34
780-210HD	Roton Continuous Geared Hinges	34
780-211HD	Roton Continuous Geared Hinges	41
780-213HD	Roton Continuous Geared Hinges	42
780-224	Roton Continuous Geared Hinges	29
780-224HD	Roton Continuous Geared Hinges	29
780-224LL	Roton Continuous Geared Hinges	29
780-226HD	Roton Continuous Geared Hinges	30
780-226LL	Roton Continuous Geared Hinges	30
780-235HD	Roton Continuous Geared Hinges	31
780-257HD	Roton Continuous Geared Hinges	35
780-259HD	Roton Continuous Geared Hinges	43
780-300HD	Roton Continuous Geared Hinges	44
782S	Thresholds & Weatherstripping	24
783S	Thresholds & Weatherstripping	24
785S	Thresholds & Weatherstripping	29
787S	Thresholds & Weatherstripping	24
789S	Thresholds & Weatherstripping	24
790-900	Stainless Steel Continuous Hinges	10

## INDEX

Part Number	Section	Page
790-903	Stainless Steel Continuous Hinges	15
790-904	Stainless Steel Continuous Hinges	16
790-905	Stainless Steel Continuous Hinges	11
790-906	Stainless Steel Continuous Hinges	17
790-909	Stainless Steel Continuous Hinges	18
790-911	Stainless Steel Continuous Hinges	12
790-915	Stainless Steel Continuous Hinges	13
790-926	Stainless Steel Continuous Hinges	14
800	Commercial Hinges	13
800S	Thresholds & Weatherstripping	29
801S	Thresholds & Weatherstripping	27
802S	Thresholds & Weatherstripping	27, 29, 36
803S	Thresholds & Weatherstripping	29
806S	Thresholds & Weatherstripping	27
808S	Thresholds & Weatherstripping	29
810S	Thresholds & Weatherstripping	20
822S	Thresholds & Weatherstripping	38
835S	Thresholds & Weatherstripping	36
836S	Thresholds & Weatherstripping	36
837S	Thresholds & Weatherstripping	36
838S	Thresholds & Weatherstripping	36
839S	Thresholds & Weatherstripping	37
845S	Thresholds & Weatherstripping	37
846S	Thresholds & Weatherstripping	37
847S	Thresholds & Weatherstripping	37
848S	Thresholds & Weatherstripping	37
849S	Thresholds & Weatherstripping	37
859S	Thresholds & Weatherstripping	30
860S	Thresholds & Weatherstripping	30
861S	Thresholds & Weatherstripping	30
862S	Thresholds & Weatherstripping	30
863S	Thresholds & Weatherstripping	30
864S	Thresholds & Weatherstripping	31
865S	Thresholds & Weatherstripping	31
866S	Thresholds & Weatherstripping	31
870S	Thresholds & Weatherstripping	31
871S	Thresholds & Weatherstripping	31
872S	Thresholds & Weatherstripping	27, 37
873S	Thresholds & Weatherstripping	31
874S	Thresholds & Weatherstripping	32, 38
875S	Thresholds & Weatherstripping	32
877S	Thresholds & Weatherstripping	32
878S	Thresholds & Weatherstripping	32
880S	Thresholds & Weatherstripping	32

Part Number	Section	Page
881S	Thresholds & Weatherstripping	32
882S	Thresholds & Weatherstripping	28, 33, 38
883S	Thresholds & Weatherstripping	33
884S	Thresholds & Weatherstripping	28
885S	Thresholds & Weatherstripping	33
890S	Thresholds & Weatherstripping	33
891S	Thresholds & Weatherstripping	34
892S	Thresholds & Weatherstripping	34
893S	Thresholds & Weatherstripping	34
896S	Thresholds & Weatherstripping	34
901P	Trim & Auxiliary	69
902P	Trim & Auxiliary	69
903P	Trim & Auxiliary	69
910B	Trim & Auxiliary	13
910P	Trim & Auxiliary	13
915B	Trim & Auxiliary	13
915P	Trim & Auxiliary	13
920	Commercial Hinges	13
920B	Trim & Auxiliary	14
920P	Trim & Auxiliary	14
921B	Trim & Auxiliary	14
921P	Trim & Auxiliary	14
922B	Trim & Auxiliary	14
922P	Trim & Auxiliary	14
923B	Trim & Auxiliary	14
923P	Trim & Auxiliary	14
924B	Trim & Auxiliary	15
924P	Trim & Auxiliary	15
925B	Trim & Auxiliary	15
925P	Trim & Auxiliary	15
926B	Trim & Auxiliary	15
926P	Trim & Auxiliary	15
930B	Trim & Auxiliary	15
930P	Trim & Auxiliary	15
932B	Trim & Auxiliary	16
932P	Trim & Auxiliary	16
933B	Trim & Auxiliary	16
933P	Trim & Auxiliary	16
934B	Trim & Auxiliary	16
934P	Trim & Auxiliary	16
936P	Trim & Auxiliary	69
937P	Trim & Auxiliary	69
940P	Trim & Auxiliary	69
941P	Trim & Auxiliary	69
945P	Trim & Auxiliary	70

# INDEX

Part Number	Section	Page
946P	Trim & Auxiliary	70
951P	Trim & Auxiliary	70
952P	Trim & Auxiliary	70
956P	Trim & Auxiliary	70
957P	Trim & Auxiliary	70
960B	Trim & Auxiliary	16
960P	Trim & Auxiliary	16
961B	Trim & Auxiliary	17
961P	Trim & Auxiliary	17
962P	Trim & Auxiliary	17
963P	Trim & Auxiliary	17
967P	Trim & Auxiliary	17
970P	Trim & Auxiliary	18
974B	Trim & Auxiliary	18
974P	Trim & Auxiliary	18
975B	Trim & Auxiliary	18
975P	Trim & Auxiliary	18
976B	Trim & Auxiliary	19
976P	Trim & Auxiliary	19
980B	Trim & Auxiliary	19
980P	Trim & Auxiliary	19
981B	Trim & Auxiliary	19
981P	Trim & Auxiliary	19
982B	Trim & Auxiliary	19
982P	Trim & Auxiliary	19
983B	Trim & Auxiliary	20
983P	Trim & Auxiliary	20
984B	Trim & Auxiliary	20
984P	Trim & Auxiliary	20
985B	Trim & Auxiliary	20
985P	Trim & Auxiliary	20
986B	Trim & Auxiliary	20
986P	Trim & Auxiliary	20
987B	Trim & Auxiliary	21
987P	Trim & Auxiliary	21
988B	Trim & Auxiliary	21
988P	Trim & Auxiliary	21
990	Commercial Hinges	44
990B	Trim & Auxiliary	21
990P	Trim & Auxiliary	21
992	Commercial Hinges	44
1129	Commercial Hinges	27
1150	Commercial Hinges	22
1151	Commercial Hinges	22
1152	Commercial Hinges	22
1173	Commercial Hinges	32

Part Number	Section	Page
1191	Commercial Hinges	15
1200-600XHD	Roton Continuous Geared Hinges	45
1200-650XHD	Roton Continuous Geared Hinges	46
1250	Commercial Hinges	22
1251	Commercial Hinges	22
1252	Commercial Hinges	22
1253	Commercial Hinges	33
1255	Commercial Hinges	22
1256	Commercial Hinges	22
1257	Commercial Hinges	23
1258	Commercial Hinges	23
1259	Commercial Hinges	23
1260   1261	Commercial Hinges	36
1267	Commercial Hinges	23
1277	Commercial Hinges	34
1278	Commercial Hinges	34
1279	Commercial Hinges	15
1303	Commercial Hinges	30
1412	Trim & Auxiliary	86
1413	Trim & Auxiliary	87
1414	Trim & Auxiliary	87
1415	Trim & Auxiliary	87
1416	Trim & Auxiliary	87
1418	Trim & Auxiliary	88
1419	Trim & Auxiliary	88
1439	Trim & Auxiliary	88
1442	Trim & Auxiliary	68
1443	Trim & Auxiliary	68
1445	Trim & Auxiliary	88
1446	Trim & Auxiliary	89
1447	Trim & Auxiliary	89
1448	Trim & Auxiliary	89
1449	Trim & Auxiliary	89
1541	Residential	3
1543	Residential	3
1577	Commercial Hinges	34
1578	Commercial Hinges	34
1700	Residential	8
1710	Residential	8
1710	Trim & Auxiliary	88
1712	Commercial Hinges	46
1713	Commercial Hinges	46
1716	Commercial Hinges	46
1717	Commercial Hinges	46
1720	Residential	8
1722	Commercial Hinges	46

## INDEX

Part Number	Section	Page
1723	Commercial Hinges	46
1728	Commercial Hinges	46
1729	Commercial Hinges	46
1734	Residential	7
1741	Residential	4
1741	Sliding Door Hardware	27, 59
1744	Residential	7
1750	Residential	7
1754	Residential	7
1755	Trim & Auxiliary	83
1756	Trim & Auxiliary	84
1758	Trim & Auxiliary	84
1759	Trim & Auxiliary	84
1760	Residential	7
1764	Residential	7
1765	Trim & Auxiliary	84
1766	Trim & Auxiliary	84
1795	Trim & Auxiliary	90
1797	Trim & Auxiliary	90
1798	Trim & Auxiliary	91
1799	Trim & Auxiliary	91
1801	Trim & Auxiliary	91
1816	Residential	5
1817	Residential	5
1818	Residential	5
1819	Residential	5
1848	Residential	5
1850	Commercial Hinges	30
1850-LP	Commercial Hinges	30
2300 Series	Locks	3
2500 Series	Locks	9
2610	Trim & Auxiliary	71
2610	Sliding Door Hardware	5, 7, 40, 59
2620	Trim & Auxiliary	72
2630	Trim & Auxiliary	72
2630	Sliding Door Hardware	40, 59
2640	Trim & Auxiliary	72
2901	Electrified Solutions	49
2901	Exit Devices	20, 39
2902	Electrified Solutions	48
2902	Exit Devices	20, 39
2903	Electrified Solutions	47
2903	Exit Devices	20, 39
2903	Locks	31, 68

Part Number	Section	Page
2904	Electrified Solutions	46
2904	Exit Devices	20, 39
2908	Electrified Solutions	43
2908	Exit Devices	20, 39
2908	Locks	31, 68
2909	Electrified Solutions	42
2909	Exit Devices	20, 39
2909	Locks	31, 68
2915	Electrified Solutions	25
2916	Electrified Solutions	26
2916P	Electrified Solutions	26
2925	Electrified Solutions	6
2928	Electrified Solutions	7
2930	Electrified Solutions	8
2941	Electrified Solutions	13
2942	Electrified Solutions	14
2951	Electrified Solutions	16
2952	Electrified Solutions	16
2953	Electrified Solutions	16
2954	Electrified Solutions	16
2958	Electrified Solutions	11
2958T	Electrified Solutions	11
2961	Electrified Solutions	20
2965	Electrified Solutions	21
2972-M	Electrified Solutions	30
2972-T	Electrified Solutions	30
2973	Electrified Solutions	31
2977	Electrified Solutions	33
2978	Electrified Solutions	24, 34
3100 Series	Locks	17
3200 Series	Locks	21
3400 Series	Locks	25
3500 Series	Locks	35
3600 Series	Locks	43
3700 Series	Locks	49
3800 Series	Locks	55
3835	Sliding Door Hardware	31, 33, 35, 37, 41, 63
3901	Exit Devices	63
3901	Locks	75, 78-79, 81-82
3902	Electrified Solutions	24
3902	Locks	69-72, 76, 78, 80-82
3903	Locks	75

# INDEX

Part Number	Section	Page
3904	Locks	76
3905	Locks	76
3906	Locks	81
3907	Locks	81-82
3908	Locks	81-82
3909	Locks	82
3911	Locks	15, 33
3912	Locks	42
3914	Locks	48
3915	Locks	48
3916	Locks	32
3917	Locks	14, 42
3919	Locks	79
3920	Locks	53
3921	Locks	53
3922	Locks	14, 41
3923	Locks	14, 41
3924	Locks	14, 41
3925	Locks	14, 41
3926	Locks	14, 41
3927	Locks	14, 41
3929	Locks	20, 24
3930	Locks	20, 24, 53
3932	Locks	32
3933	Locks	7, 15, 33, 42, 48, 53
3934	Locks	15, 33, 42, 48, 53
3935	Locks	7, 15, 33, 42, 48
3936	Locks	32
3937	Locks	14, 42
3938	Locks	48
3939	Locks	48
3940	Locks	20, 24
3941	Locks	20, 24
3942	Locks	24
3943	Locks	32
3944	Locks	32
3945	Locks	32
3946	Locks	32
3947	Locks	14, 41, 53

Part Number	Section	Page
3948	Locks	14, 41, 53
3949	Locks	14, 41, 53
3950	Locks	14, 41, 53
3951	Locks	48
3952	Locks	48
3953	Locks	48
3954	Locks	48
3955	Locks	74
3956	Locks	74, 79
3958	Locks	15, 33, 42, 48, 53
3959	Locks	7, 15, 42, 48, 53
3960 or 3906 (Hager Keyway Only)	Locks	75, 81
3961	Locks	74
3962	Locks	74, 79
3964	Locks	32
3965	Locks	14, 41
3966	Locks	32
3967	Locks	14, 41
3969	Locks	82
3971	Locks	76
3972	Locks	76
3973	Locks	76
3974	Locks	76
3975	Locks	76
3976	Locks	76
3977	Locks	76
3978	Locks	76
3981-BLU or RED (Best A)	Locks	77
3981-C	Locks	77
3981-U	Locks	77
3982-BLU or RED (Best A)	Locks	77
3982-C or 3969 (Hager SFIC Only)	Locks	77, 82
3982-U or 3909 (Hager SFIC Only)	Locks	77, 82
3983	Locks	77
3984	Locks	77
3985	Locks	69
3986	Locks	69
3987	Locks	69



## INDEX

Part Number	Section	Page
3988	Locks	69
3989	Locks	69
3990	Locks	69
3991	Locks	70
3992	Locks	32
3993	Locks	32
3994	Locks	41
3995	Locks	41
3996	Locks	41
3997	Locks	41
3999	Locks	71
4500 CLB	Exit Devices	14
4500 CLB/ CVR Electrified	Exit Devices	15
4500 CVR	Exit Devices	13
4500 Dummy	Exit Devices	18
4500 LBR	Exit Devices	11
4500 LBR/ SVR Electrified	Exit Devices	12
4500 Mortise	Exit Devices	16
4500 Mortise Electrified	Exit Devices	17
4500 RIM	Exit Devices	8
4500 RIM Electrified	Exit Devices	9
4500 Series	Exit Devices	3
4500 Series - Electric Modifications	Exit Devices	20
4500 SVR	Exit Devices	10
4501	Electrified Solutions	9
4600 RIM	Exit Devices	36
4600 RIM Electrified	Exit Devices	37
4600 Series	Exit Devices	18
4600 Series - Electric Modifications	Exit Devices	19
4700 RIM	Exit Devices	48
4700 Series	Exit Devices	43
4700 SVR	Exit Devices	49
4801	Electrified Solutions	35
4900 Series	Exit Devices	59
4900T	Exit Devices	61
4900TF	Exit Devices	61
4900U	Exit Devices	62
4900UF	Exit Devices	62
4902	Exit Devices	63
4902F	Exit Devices	63

Part Number	Section	Page
4904	Exit Devices	64
4904F	Exit Devices	64
4905	Exit Devices	64
4907	Exit Devices	63
4910	Exit Devices	55
4911	Exit Devices	55
4912	Exit Devices	63
4913	Exit Devices	55
4914	Exit Devices	55
4915	Exit Devices	27, 55
4916	Exit Devices	63
4917	Exit Devices	56
4917F	Exit Devices	56
4918	Exit Devices	56
4919	Exit Devices	56
4920	Exit Devices	27, 42
4920F	Exit Devices	27, 42
4921	Exit Devices	27
4923	Exit Devices	27
4923F	Exit Devices	27
4924	Exit Devices	27
4924F	Exit Devices	27
4925R	Exit Devices	42
4926	Exit Devices	28
4927	Exit Devices	28
4928	Exit Devices	28
4929	Exit Devices	28
4929C	Exit Devices	28
4930R	Exit Devices	28
4930S	Exit Devices	28
4931R	Exit Devices	56
4931S	Exit Devices	56
4932C	Exit Devices	29
4932R	Exit Devices	29
4932S	Exit Devices	29
4933R	Exit Devices	56
4933S	Exit Devices	56
4934	Exit Devices	57
4934F	Exit Devices	57
4936	Exit Devices	29, 57
4937	Exit Devices	29, 57
4940	Exit Devices	19
4941	Exit Devices	38
4945	Exit Devices	27
4945F	Exit Devices	27

## INDEX

Part Number	Section	Page
4950	Exit Devices	42
4951	Exit Devices	42
4952	Exit Devices	42
4953	Exit Devices	63
4960R	Exit Devices	42
4965	Exit Devices	42
5100 Series	Door Controls	5
5101	Door Controls	10
5102	Door Controls	10
5103	Door Controls	9
5104	Door Controls	11
5106	Door Controls	9
5107	Door Controls	9
5108	Door Controls	9
5109	Door Controls	10
5110	Door Controls	10
5111	Door Controls	10
5112	Door Controls	10
5113	Door Controls	10
5114	Door Controls	10
5115	Door Controls	10
5125	Door Controls	9
5200 Series	Door Controls	13
5201	Door Controls	18
5202	Door Controls	18
5203	Door Controls	17
5204	Door Controls	19
5207	Door Controls	17
5300 Series	Door Controls	21
5301	Door Controls	26
5302	Door Controls	26
5303	Door Controls	25
5304	Door Controls	27
5307	Door Controls	25
5400 Series	Door Controls	29
5401	Door Controls	33
5403	Door Controls	33
5404	Door Controls	33
5900	Door Controls	18, 26, 33
5901	Door Controls	26, 33
5902	Door Controls	19, 27, 33
5903	Door Controls	19, 27, 33
5904	Door Controls	19, 27, 33

Part Number	Section	Page
5905	Door Controls	19, 27, 33
5906	Door Controls	17, 25
5907	Door Controls	17, 25
5908	Door Controls	18, 26
5909	Door Controls	10
5911	Door Controls	17, 25
5912	Door Controls	17, 25
5913	Door Controls	18, 26, 33
5914	Door Controls	18, 26
5915	Door Controls	26
5916	Door Controls	26
5917	Door Controls	27
5918	Door Controls	18
5919	Door Controls	18
5920	Door Controls	18
5921	Door Controls	18
5922	Door Controls	18
5923	Door Controls	18
5932	Door Controls	19
5935	Door Controls	10
5936	Door Controls	19, 26
5940	Door Controls	11
5941	Door Controls	11
5942	Door Controls	11
5943	Door Controls	11
5946	Door Controls	11
5950	Door Controls	10, 19, 26
5954	Door Controls	9
5955	Door Controls	9
5956	Door Controls	17, 25
5957	Door Controls	17, 25
5961	Door Controls	9
5962	Door Controls	10
6000 Series	Door Controls	46
6601	Trim & Auxiliary	91
7000 Series	Door Controls	47
7741	Residential	4
8218	Electrified Solutions	69
8219	Electrified Solutions	69
8221	Electrified Solutions	69
8418	Electrified Solutions	60
8419	Electrified Solutions	60
8420	Electrified Solutions	60
8422	Electrified Solutions	60

# INDEX

Part Number	Section	Page
8423	Electrified Solutions	60
8641	Residential	6
8741	Residential	6
8744	Residential	5
8746	Residential	5
9101	Sliding Door Hardware	12, 13, 31
9102	Sliding Door Hardware	13, 31
9105	Sliding Door Hardware	13, 31
9109	Sliding Door Hardware	13, 31
9110	Sliding Door Hardware	12, 30
9111	Sliding Door Hardware	59
9113	Sliding Door Hardware	60
9114	Sliding Door Hardware	60
9115	Sliding Door Hardware	13, 31, 46
9121	Sliding Door Hardware	60
9122	Sliding Door Hardware	60
9129	Sliding Door Hardware	13, 31
9130	Sliding Door Hardware	12, 30
9169	Sliding Door Hardware	60
9200	Sliding Door Hardware	60
9201	Sliding Door Hardware	60
9202	Sliding Door Hardware	60
9203	Sliding Door Hardware	60
9220	Sliding Door Hardware	23, 60
9262	Sliding Door Hardware	61
9264	Sliding Door Hardware	61
9351	Sliding Door Hardware	5, 7, 61
9353	Sliding Door Hardware	5, 61
9354	Sliding Door Hardware	61
9400	Sliding Door Hardware	5, 48
9401	Sliding Door Hardware	5, 7
9432	Sliding Door Hardware	49
9433	Sliding Door Hardware	49
9435	Sliding Door Hardware	50
9436	Sliding Door Hardware	50
9437	Sliding Door Hardware	51
9438	Sliding Door Hardware	51
9450	Residential	11
9450	Sliding Door Hardware	54, 55
9452	Residential	11
9452	Sliding Door Hardware	55
9453	Residential	11
9453	Sliding Door Hardware	55

Part Number	Section	Page
9454	Residential	12
9454	Sliding Door Hardware	56
9455	Residential	12
9455	Sliding Door Hardware	56
9462	Sliding Door Hardware	52
9514	Sliding Door Hardware	4
9540	Sliding Door Hardware	7
9544	Sliding Door Hardware	7
9558	Trim & Auxiliary	72
9558	Sliding Door Hardware	23, 61
9559	Sliding Door Hardware	23, 25, 27, 61
9566	Trim & Auxiliary	72
9567	Trim & Auxiliary	73
9569	Sliding Door Hardware	23
9570	Sliding Door Hardware	22
9571	Sliding Door Hardware	23
9572	Sliding Door Hardware	23, 61
9573	Sliding Door Hardware	15
9574	Sliding Door Hardware	17
9575	Sliding Door Hardware	61
9583	Sliding Door Hardware	4
9601	Sliding Door Hardware	23, 33
9602	Sliding Door Hardware	11
9603	Sliding Door Hardware	9
9605	Sliding Door Hardware	9, 11, 33, 40, 61
9606	Sliding Door Hardware	9, 11, 33, 41, 61
9609	Sliding Door Hardware	9
9610	Sliding Door Hardware	8, 11, 62
9611	Sliding Door Hardware	14
9612	Sliding Door Hardware	14
9614	Sliding Door Hardware	6
9618	Sliding Door Hardware	23
9628	Sliding Door Hardware	38
9629	Sliding Door Hardware	38
9630	Sliding Door Hardware	38
9631	Sliding Door Hardware	38
9632	Sliding Door Hardware	33, 41
9633	Sliding Door Hardware	33, 41
9634	Sliding Door Hardware	62
9639	Sliding Door Hardware	62
9673	Sliding Door Hardware	8

# INDEX

Part Number	Section	Page
9674	Sliding Door Hardware	8
9675	Sliding Door Hardware	10
9676	Sliding Door Hardware	10
9678	Sliding Door Hardware	32
9679	Sliding Door Hardware	9, 11
9680	Sliding Door Hardware	9, 11, 62
9683	Sliding Door Hardware	6
9703	Sliding Door Hardware	45
9704	Sliding Door Hardware	45
9705	Sliding Door Hardware	45
9709	Sliding Door Hardware	62
9710	Sliding Door Hardware	44
9711	Sliding Door Hardware	45
9742	Sliding Door Hardware	35
9801	Sliding Door Hardware	17, 27, 35
9803	Sliding Door Hardware	19
9809	Sliding Door Hardware	17
9810	Sliding Door Hardware	5
9814	Sliding Door Hardware	5
9815	Sliding Door Hardware	23, 25, 27, 46, 62
9820	Sliding Door Hardware	7
9821	Sliding Door Hardware	15, 25, 37
9824	Sliding Door Hardware	15
9825	Sliding Door Hardware	15, 25, 37
9827	Sliding Door Hardware	17, 19, 27, 35, 41, 46
9828	Sliding Door Hardware	25, 27
9841	Sliding Door Hardware	5, 7
9842	Sliding Door Hardware	7
9843	Sliding Door Hardware	7
9850	Sliding Door Hardware	39
9860	Sliding Door Hardware	24
9861	Sliding Door Hardware	24
9865	Trim & Auxiliary	73, 62
9865	Sliding Door Hardware	5
9875	Sliding Door Hardware	16
9877	Sliding Door Hardware	62

Part Number	Section	Page
9878	Sliding Door Hardware	34
9880	Sliding Door Hardware	19, 62
9881	Sliding Door Hardware	33, 35, 37, 63
9882	Trim & Auxiliary	73
9883	Sliding Door Hardware	33, 35, 37, 63
9884	Trim & Auxiliary	73
9884	Sliding Door Hardware	63
9885	Sliding Door Hardware	18
9886	Sliding Door Hardware	18
9889	Sliding Door Hardware	63
9890	Sliding Door Hardware	26
9891	Sliding Door Hardware	26
9892	Sliding Door Hardware	15
9893	Sliding Door Hardware	15
9894	Sliding Door Hardware	25
9895	Sliding Door Hardware	37
9901	Sliding Door Hardware	36
9909	Sliding Door Hardware	9, 11, 15, 17, 19, 63
9928	Sliding Door Hardware	63
A30, A40, A50 Series	Trim & Auxiliary	26
A30S	Trim & Auxiliary	28
A40R	Trim & Auxiliary	28
A50T	Trim & Auxiliary	28
AB700	Commercial Hinges	13, 21
AB701	Commercial Hinges	26
AB702	Commercial Hinges	28
AB703	Commercial Hinges	31
AB750	Commercial Hinges	14, 21
AB751	Commercial Hinges	26
AB752	Commercial Hinges	28
AB753	Commercial Hinges	31
AB800	Commercial Hinges	13, 21
AB801	Commercial Hinges	26
AB802	Commercial Hinges	28
AB803	Commercial Hinges	31
AB850	Commercial Hinges	14, 21
AB851	Commercial Hinges	26

## INDEX

Part Number	Section	Page
AB852	Commercial Hinges	28
AB853	Commercial Hinges	31
AB920	Commercial Hinges	13
AB923	Commercial Hinges	13
AB930	Commercial Hinges	13
AB933	Commercial Hinges	13
AB7001   AB7002	Commercial Hinges	35
AB7501   AB7502	Commercial Hinges	35
AB7505	Commercial Hinges	38
AB7506   AB7508	Commercial Hinges	38
AB7507   AB7509	Commercial Hinges	38
AB7511   AB7512	Commercial Hinges	35
AB7523	Commercial Hinges	35
AB7534	Commercial Hinges	35
AB8505	Commercial Hinges	38
AB8506   AB8508	Commercial Hinges	38
AB8507   AB8509	Commercial Hinges	38
BB1109	Commercial Hinges	27
BB1129	Commercial Hinges	27
BB1138	Commercial Hinges	27
BB1160	Commercial Hinges	39
BB1162   BB1166	Commercial Hinges	39
BB1163	Commercial Hinges	32
BB1165   BB1167	Commercial Hinges	39
BB1168	Commercial Hinges	9, 18, 21
BB1173	Commercial Hinges	33
BB1190	Commercial Hinges	39
BB1191	Commercial Hinges	9, 17, 21
BB1192   BB1196	Commercial Hinges	39
BB1195   BB1197	Commercial Hinges	39
BB1199	Commercial Hinges	9, 18, 21
BB1260   BB1261	Commercial Hinges	36
BB1262   BB1263	Commercial Hinges	36
BB1264   BB1265	Commercial Hinges	37
BB1266	Commercial Hinges	37
BB1270	Commercial Hinges	37
BB1277	Commercial Hinges	34
BB1278	Commercial Hinges	34
BB1279	Commercial Hinges	9, 17, 21
BB1360   BB1361	Commercial Hinges	36
BB1362   BB1363	Commercial Hinges	37
BB1541	Residential	3
BB1543	Residential	3

Part Number	Section	Page
BB1577	Commercial Hinges	34
BB1578	Commercial Hinges	34
BB1741	Residential	4
BB1816	Residential	5
BB1817	Residential	5
BB2098	Commercial Hinges	27
BB2108	Commercial Hinges	29
BB2109	Commercial Hinges	29
BB2110	Commercial Hinges	30
BB2112	Commercial Hinges	33
BB2113	Commercial Hinges	32
BB2168	Commercial Hinges	29
BB2169	Commercial Hinges	29
BB2171	Commercial Hinges	30
BL232W	Trim & Auxiliary	43
BL236W	Trim & Auxiliary	43
BL241F	Trim & Auxiliary	49
BL243F	Trim & Auxiliary	49
BL6209	Trim & Auxiliary	85
BL6211	Trim & Auxiliary	86
BL6212	Trim & Auxiliary	86
BL6439	Trim & Auxiliary	88
BL6610	Trim & Auxiliary	91
BL6793	Trim & Auxiliary	90
BL6794	Trim & Auxiliary	90
CB1191	Commercial Hinges	16
Cylinder, Core and Keying	Locks	73
E1S	Commercial Hinges	19
E2	Commercial Hinges	19
E2/E1S	Commercial Hinges	19
EC1100   EC1100NRP	Commercial Hinges	24
EC1101	Commercial Hinges	24
EC1105	Commercial Hinges	25
ECBB1100   ECBB1100NRP	Commercial Hinges	24
ECBB1101   ECBB1101NRP	Commercial Hinges	24
ECBB1102   ECBB1102NRP	Commercial Hinges	25
ECBB1103   ECBB1103NRP	Commercial Hinges	25
ECRC1100	Commercial Hinges	24
ECRCBB1100	Commercial Hinges	24
EMN	Commercial Hinges	20
ETM	Commercial Hinges	20
ETW	Commercial Hinges	20

## INDEX

Part Number	Section	Page
IHTAB750	Commercial Hinges	44
IHTAB850	Commercial Hinges	44
IHTHB953	Commercial Hinges	44
P4E	Trim & Auxiliary	6
P8N	Trim & Auxiliary	8
RC1541	Residential	3
RC1542	Residential	3
RC1641	Residential	6
RC1734	Residential	7
RC1741	Residential	4
RC1744	Residential	7
RC1748	Residential	4
RC1749	Residential	4
RC1751	Residential	7
RC1752	Residential	7
RC1761	Residential	7
RC1762	Residential	7
RC1841	Residential	6
RC1842	Residential	6
RC1843	Residential	6
RC1846	Residential	6
RC1847	Residential	6
RCBB1541	Residential	3
RCBB1542	Residential	3
RCBB1741	Residential	4
RCBB1842	Residential	6
T4E	Trim & Auxiliary	6
WT1191	Commercial Hinges	16
WT1279	Commercial Hinges	16
WTAB700	Commercial Hinges	14
WTAB750	Commercial Hinges	15
WTAB800	Commercial Hinges	14
WTAB850	Commercial Hinges	15
WTBB1168	Commercial Hinges	18
WTBB1191	Commercial Hinges	17
WTBB1199	Commercial Hinges	18
WTBB1279	Commercial Hinges	17
1-269-8689	Residential	13
1-269-8689	Sliding Door Hardware	57
1-269-8690	Residential	13
1-269-8690	Sliding Door Hardware	57
1-269-8691	Residential	13
1-269-8691	Sliding Door Hardware	57
1-269-8693	Residential	13
1-269-8693	Sliding Door Hardware	57
1-269-8694	Residential	13

Part Number	Section	Page
1-269-8694	Sliding Door Hardware	57
2-300-0118	Locks	76, 78
2-300-0175	Locks	79
2-639-7000	Locks	75
2-639-7001	Locks	75
2-639-7002	Locks	75
2-639-7003	Locks	75
2-639-7005	Locks	75
2-639-7006	Locks	75
2-639-7007	Locks	75
2-639-7008	Locks	75
2-639-7018	Locks	75
2-639-7058	Locks	76, 78
2-639-7060	Locks	78
2-639-7061	Locks	78
2-639-7082	Locks	78
2-639-7083	Locks	78
2-639-7084	Locks	78
2-639-7085	Locks	78
2-639-7086	Locks	78
2-639-7087	Locks	75
2-639-7090	Locks	78
2-639-7091	Locks	78
2-639-7094	Locks	75
2-639-7095	Locks	78
2-639-7113	Locks	77
2-639-7168	Locks	77
2-639-7169	Locks	77
2-639-7170	Locks	77
2-639-7192	Locks	75
2-639-7322	Locks	75
2-639-7511	Locks	83
2-639-7517	Locks	83
2-639-7519	Locks	83
2-639-7520	Locks	83
2-639-7526	Locks	83
2-639-7527	Locks	83
2-639-7529	Locks	83
2-639-7530	Locks	83
2-639-7531	Locks	83
2-639-7532	Locks	83
2-639-7534	Locks	83
2-639-7535	Locks	83
2-639-7536	Locks	83
2-639-7570	Locks	80
2-639-7571	Locks	80

## INDEX

Part Number	Section	Page
2-639-7572	Locks	80
2-639-7573	Locks	80
2-639-7574	Locks	80
2-639-7578	Locks	79
2-639-7607	Locks	7
2-639-7608	Locks	7
2-639-7609	Locks	7
2-639-7610	Locks	7
2-639-7645	Locks	79
2-639-7646	Locks	79
2-639-7647	Locks	79
2-639-7649	Locks	79
2-639-7660	Locks	79
2-639-8188	Locks	84
2-639-8189	Locks	84
2-639-8190	Locks	84
2-639-8191	Locks	84
2-639-8192	Locks	84
2-639-8193	Locks	84
2-639-8194	Locks	84
2-639-8195	Locks	84
2-639-8196	Locks	84
2-639-8197	Locks	84
2-639-8198	Locks	84
2-639-8199	Locks	84
2-639-8200	Locks	84
2-639-8201	Locks	84
2-639-8202	Locks	84
2-639-8203	Locks	84
2-639-8204	Locks	84
2-639-8205	Locks	84
2-639-8210	Locks	84
2-639-8211	Locks	84
2-639-8212	Locks	84
2-639-8213	Locks	84
2-639-8214	Locks	84
2-639-8215	Locks	84
2-639-8216	Locks	84
2-639-8217	Locks	84
2-639-8218	Locks	84
2-639-8219	Locks	84
2-639-8220	Locks	84
2-639-8221	Locks	84
2-639-8222	Locks	84
2-639-8223	Locks	84
2-639-8224	Locks	84

Part Number	Section	Page
2-639-8225	Locks	84
2-639-8226	Locks	84
2-639-8227	Locks	84
2-639-8228	Locks	84
2-639-8229	Locks	84
2-649-0038	Exit Devices	29, 42
2-649-0039	Exit Devices	29, 42
2-649-0040	Exit Devices	29, 42
2-649-0041	Exit Devices	29, 42
2-649-0042	Exit Devices	29, 42
2-649-0043	Exit Devices	29, 42
2-649-0044	Exit Devices	29, 42
2-649-0137	Locks	76, 78
2-649-0144	Exit Devices	57
2-649-0145	Exit Devices	57
2-649-0146	Exit Devices	57
2-649-0147	Exit Devices	57
2-649-0166	Exit Devices	29
2-649-0203	Exit Devices	27
2-649-0204	Exit Devices	27
2-649-0205	Exit Devices	27
2-649-0206	Exit Devices	27
2-649-0207	Exit Devices	27
2-649-0208	Exit Devices	27
2-649-0214	Exit Devices	29, 42
2-649-0215	Exit Devices	29, 42
2-649-0216	Exit Devices	29, 42
2-649-0217	Exit Devices	29, 42
2-649-0218	Exit Devices	29, 42
2-649-0219	Exit Devices	29, 42
2-649-0220	Exit Devices	29, 42
2-649-0250	Exit Devices	28, 42
2-649-0257	Exit Devices	28, 42
2-659-0098	Door Controls	46
2-659-0099	Door Controls	46
2-659-0100	Door Controls	46
2-659-0101	Door Controls	46
2-659-0102	Door Controls	46
2-659-0103	Door Controls	46
2-659-0104	Door Controls	46
2-659-0105	Door Controls	46
2-659-0106	Door Controls	46
2-659-0107	Door Controls	46
2-659-0108	Door Controls	46
2-659-0109	Door Controls	46
2-659-0110	Door Controls	46

## INDEX

Part Number	Section	Page
2-659-0111	Door Controls	46
2-659-0112	Door Controls	46
2-659-0113	Door Controls	46
2-659-0114	Door Controls	46
2-659-0115	Door Controls	46
2-659-0116	Door Controls	48
2-659-0117	Door Controls	48
2-659-0118	Door Controls	48
2-659-0119	Door Controls	48
2-659-0120	Door Controls	48
2-659-0121	Door Controls	48
2-659-0122	Door Controls	48
2-659-0123	Door Controls	48
2-659-0124	Door Controls	48
2-659-0125	Door Controls	48
2-659-0126	Door Controls	48
2-659-0127	Door Controls	48
2-659-0128	Door Controls	48
2-659-0129	Door Controls	48
2-659-0130	Door Controls	48
2-659-0131	Door Controls	48
2-659-0132	Door Controls	48
2-659-0133	Door Controls	48
2-659-0151	Electrified Solutions	64
2-659-0152	Electrified Solutions	64
2-659-0153	Electrified Solutions	64
2-659-0154	Electrified Solutions	64
2-659-0161	Electrified Solutions	80
2-659-0162	Electrified Solutions	80
2-659-0163	Electrified Solutions	80
2-659-0164	Electrified Solutions	80
2-659-0165	Electrified Solutions	79
2-659-0166	Electrified Solutions	79
2-659-0167	Electrified Solutions	79
2-659-0168	Electrified Solutions	79
2-659-0169	Electrified Solutions	78
2-659-0170	Electrified Solutions	78
2-659-0171	Electrified Solutions	78
2-659-0172	Electrified Solutions	77
2-659-0173	Electrified Solutions	77
2-659-0174	Electrified Solutions	77, 86
2-659-0175	Electrified Solutions	81
2-659-0176	Electrified Solutions	81
2-659-0177	Electrified Solutions	81
2-659-0178	Electrified Solutions	82
2-659-0179	Electrified Solutions	82

Part Number	Section	Page
2-659-0180	Electrified Solutions	84
2-659-0181	Electrified Solutions	84
2-659-0182	Electrified Solutions	84
2-659-0183	Electrified Solutions	86
2-659-0185	Electrified Solutions	86
2-659-0186	Electrified Solutions	86
2-659-0187	Door Controls	9
2-659-0188	Door Controls	9
2-659-0189	Door Controls	9
2-659-0190	Door Controls	9
2-659-0191	Door Controls	17, 25
2-659-0192	Door Controls	17, 25
2-659-0193	Door Controls	17, 25
2-659-0194	Door Controls	17, 25
2-659-0195	Door Controls	9
2-659-0196	Door Controls	9
2-659-0197	Door Controls	9
2-659-0198	Door Controls	9
2-659-0199	Door Controls	17, 25
2-659-0200	Door Controls	17, 25
2-659-0201	Door Controls	17, 25
2-659-0202	Door Controls	17, 25
2-659-0203	Door Controls	9
2-659-0204	Door Controls	9
2-659-0205	Door Controls	9
2-659-0206	Door Controls	9
2-659-0207	Door Controls	9
2-659-0208	Door Controls	9
2-659-0209	Door Controls	9
2-659-0210	Door Controls	9
2-659-0211	Door Controls	17
2-659-0212	Door Controls	17
2-659-0213	Door Controls	17
2-659-0214	Door Controls	17
2-659-0215	Door Controls	17
2-659-0216	Door Controls	17
2-659-0217	Door Controls	17
2-659-0218	Door Controls	17
2-659-0220	Electrified Solutions	64
2-659-0221	Electrified Solutions	64
2-659-0222	Electrified Solutions	64
2-659-0223	Electrified Solutions	64
2-659-0224	Electrified Solutions	64
2-659-0225	Electrified Solutions	64
2-659-0226	Electrified Solutions	64
2-659-0227	Electrified Solutions	64



# INDEX

Part Number	Section	Page
2-659-0228	Electrified Solutions	64
2-659-0229	Electrified Solutions	64
2-659-0230	Electrified Solutions	65
2-659-0231	Electrified Solutions	65
2-659-0232	Electrified Solutions	65
2-659-0233	Electrified Solutions	65
2-659-0234	Electrified Solutions	65
2-659-0235	Electrified Solutions	65
2-659-0236	Electrified Solutions	65
2-659-0237	Electrified Solutions	86
2-659-0240	Electrified Solutions	87
2-659-0241	Electrified Solutions	77, 79
2-659-0242	Electrified Solutions	83
2-659-0243	Electrified Solutions	83
2-659-0275	Electrified Solutions	72
2-659-0276	Electrified Solutions	72
2-659-0277	Electrified Solutions	72
2-659-0278	Electrified Solutions	72
2-659-0279	Electrified Solutions	72
2-659-0280	Electrified Solutions	72
2-659-0283	Electrified Solutions	73
2-659-0284	Electrified Solutions	73
2-659-0285	Electrified Solutions	73
2-659-0286	Electrified Solutions	73
2-659-0287	Electrified Solutions	73
2-659-0288	Electrified Solutions	73
2-659-0289	Electrified Solutions	73
2-659-0290	Electrified Solutions	73
2-659-0291	Electrified Solutions	73
2-659-0292	Electrified Solutions	73
2-659-0293	Electrified Solutions	73
2-659-0294	Electrified Solutions	73
2-659-0295	Electrified Solutions	73
2-659-0296	Electrified Solutions	73
2-659-0297	Electrified Solutions	73
2-659-0298	Electrified Solutions	73
2-659-0299	Electrified Solutions	73
2-659-0300	Electrified Solutions	73
2-659-0303	Electrified Solutions	76
2-659-0304	Electrified Solutions	76
2-659-0305	Electrified Solutions	76
2-659-0306	Electrified Solutions	76
2-659-0307	Electrified Solutions	76
2-659-0308	Electrified Solutions	76
2-679-0028	Electrified Solutions	6, 7, 8
2-679-0029	Electrified Solutions	6, 8

Part Number	Section	Page
2-679-0100	Electrified Solutions	14, 15
2-679-0101	Electrified Solutions	13, 15
2-679-0102	Electrified Solutions	14, 15
2-679-0103	Electrified Solutions	15
2-679-0106	Electrified Solutions	13, 14, 15
2-679-0107	Electrified Solutions	13, 14, 15
2-679-0108	Electrified Solutions	13, 14, 15
2-679-0109	Electrified Solutions	17
2-679-0110	Electrified Solutions	17
2-679-0111	Electrified Solutions	17
2-679-0112	Electrified Solutions	17
2-679-0120	Electrified Solutions	17
2-679-0121	Electrified Solutions	17
2-679-0130	Electrified Solutions	17
2-679-0131	Electrified Solutions	17
2-679-0160	Electrified Solutions	17
2-679-0161	Electrified Solutions	17
2-679-0180	Electrified Solutions	17
2-679-0181	Electrified Solutions	17
2-679-0190	Electrified Solutions	17
2-679-0191	Electrified Solutions	17
2-679-0200	Electrified Solutions	18
2-679-0201	Electrified Solutions	18
2-679-0205	Electrified Solutions	18
2-679-0210	Electrified Solutions	19
2-679-0220	Electrified Solutions	19
2-659-0240	Electrified Solutions	87
2-679-0242	Electrified Solutions	10
2-679-0281	Electrified Solutions	18
2-679-0283	Electrified Solutions	18
2-679-0291	Electrified Solutions	18
2-679-0293	Electrified Solutions	18
2-679-0311	Electrified Solutions	18
2-679-0313	Electrified Solutions	18
2-679-0321	Electrified Solutions	18
2-679-0323	Electrified Solutions	18
2-679-0381	Electrified Solutions	18
2-679-0383	Electrified Solutions	18
2-679-0391	Electrified Solutions	18
2-679-0393	Electrified Solutions	18
2-679-0411	Electrified Solutions	18
2-679-0413	Electrified Solutions	18
2-679-0421	Electrified Solutions	18
2-679-0423	Electrified Solutions	18

## INDEX

Part Number	Section	Page
2-679-0491	Electrified Solutions	19
2-679-0493	Electrified Solutions	19
2-679-0501	Electrified Solutions	19
2-679-0503	Electrified Solutions	19
2-679-0571	Electrified Solutions	19
2-679-0573	Electrified Solutions	19
2-679-0581	Electrified Solutions	19
2-679-0583	Electrified Solutions	19
2-679-0600	Electrified Solutions	20
2-679-0601	Electrified Solutions	21
2-679-0611	Electrified Solutions	32
2-679-0612	Electrified Solutions	32
2-679-0620	Electrified Solutions	38
2-679-0621	Electrified Solutions	38
2-679-0622	Electrified Solutions	38
2-679-0623	Electrified Solutions	38
2-679-0624	Electrified Solutions	38
2-679-0625	Electrified Solutions	40
2-679-0626	Electrified Solutions	40
2-679-0630	Electrified Solutions	9
2-679-0641	Electrified Solutions	10
2-679-0642	Electrified Solutions	10
2-679-0650	Electrified Solutions	36
2-679-0661	Electrified Solutions	43, 44, 45
2-679-0662	Electrified Solutions	43, 44, 45
2-679-0664	Electrified Solutions	43, 44, 45
2-679-0669	Electrified Solutions	26
2-679-0708	Electrified Solutions	27



**One Family. One Brand. One Vision.™**

[www.hagerco.com](http://www.hagerco.com)