

DOR-O-MATIC®

AUTOMATIC DOOR SYSTEMS

Astro/Senior/Mid-Swing Overhead Concealed and Surface Applied

Installation Instructions

DOR-O-MATIC®
Hardware Products
121 West Railroad Avenue
Princeton, IL 61356-0100
1-800-526-2400
Fax: 800-666-0472
www.lcnclosers.com

DOR-O-MATIC®
AUTOMATIC DOOR SYSTEMS
7350 West Wilson Avenue
Harwood Heights, IL 60706-4708
1-800-543-4635
708-867-7400
Engineering Fax: 708-867-1177
www.doromatic.com



Copyright © 2003 Ingersoll-Rand. All rights reserved.



IMPORTANT

Dor-O-Matic Astro Swing

The Astro Swing Power Operator System is a high energy product and **must** conform to the latest version of ANSI/BHMAA156.10 (American National Standard for Power Operated Pedestrian Doors).

The ANSI/BHMAA156.10 Standard **must** be referenced when installing or servicing an Astro Swing Power Operator System to ensure that all applicable requirements within the standard are met. These requirements include, but are not limited to:

- the use of guide rails
- the use of sensors (motion, presence, other)
- the use of finger guards
- the use of door signage
- general door performance

Additionally, the Astro-Swing Control Box instruction manual, as well as the manufacturer's instruction manual accompanying any sensor, must be referenced to ensure proper installation, set-up, and operation.

Failure to set up the Astro Swing Power Operator System per ANSI/BHMA A156.10 requirements may result in personal injury or property damage for which the installer is **LIABLE**.

Dor-O-Matic Senior and Middle Swing

The Senior Swing Power Operator System and the Middle Swing Power Operator System are low energy products and **must** conform to the latest version of ANSI/BHMAA156.19 (American National Standard for Power Operated Pedestrian Doors).

Installation Instructions

All installation instructions are valuable references and should not be discarded. They should be given to the building owner or maintenance supervisor after installation is complete.



CAUTION

Improper installation or set up may result in personal injury or property damage. Follow all instructions carefully. For answers to questions, call Dor-O-Matic at:

Automatic Door Systems

1-800-543-4635

Hardware

1-800-815-1517



IMPORTANT

These instructions are presented in step-by-step sequence. It is very important that installation begins with “1. Pre-Installation Site and Product Check” (page 4) and continues as directed after each section.



WARNING

Always disconnect main power to the operator prior to servicing or cleaning.

CONTENTS

General	3
Pre-Installation Site and Product Check	4
Concealed Header Installation	5
Surface Header Installation	6
AC Power and Ground Wiring	8
Operator Installation	9
Pivot Block Installation	10
Breakaway or Fixed Stop Installation	11
Control Box Installation	12
Control Box Wiring	13
Finger Guard Installation	16
Center Pivoted Door and Arm Installation	17
Push, Pull, and Offset Arm Installation	19
Glazing	19
Control Box Functions	19
Header Dress Plate Installation	20
Release for Service	20

GENERAL

The Astro/Senior/Mid-Swing is an automatic electromechanical swinging door operator for a single door or simultaneously operated pair of doors. The concealed application operates center pivoted or butt hung/hinged doors. The surface application operates balanced, offset pivoted, or butt hung/hinged doors in either push or pull mode.

When activated, the Astro/Senior/Mid-Swing drives the door to the full open position, then electrical power is turned off and the door is closed by spring force. The activating circuit opens the door from any position in the closing swing. During a power failure, the swing acts as a manual door closer (Astro/Senior as size 3, Mid as size 2). Door opening and closing cycles, including opening speed, back check speed, hold open time delay, closing speed, and latch position, are adjustable.

1. PRE-INSTALLATION SITE AND PRODUCT CHECK



IMPORTANT

Do not install the Astro/Senior/Mid-Swing unless all of the following conditions are correct.

- 1.1. Check that the product model is correct for the required application.
- 1.2. Check that all parts listed on the bill of material are in the shipping container.
- 1.3. Check architectural and final approved shop drawings for position of frame and openings.
- 1.4. For concealed applications, check that the opening allows 1/4" at each side and at the top so that the frame and the header can be plumbed square and caulked.
- 1.5. Check for sufficient header clearances:

Surface Application (Push System Shown)

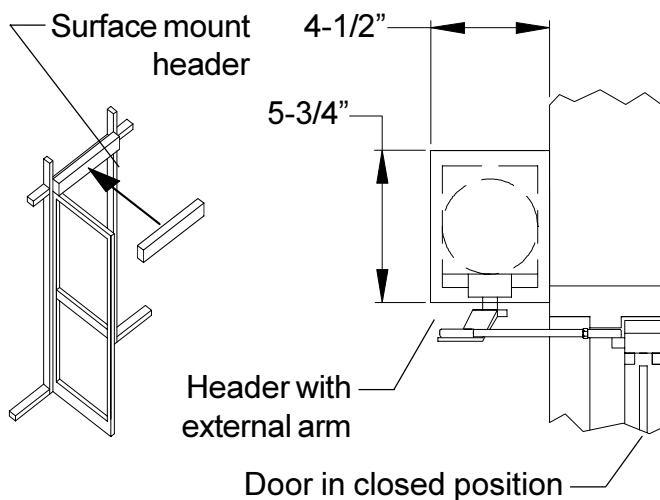

Concealed Application

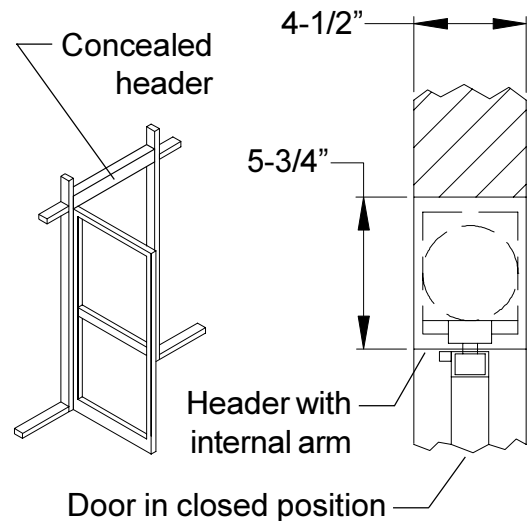

- 1.6. For a ramped floor, check that the break in the grade occurs at the edge of the 2" threshold and slopes away from the entrance to allow proper door swing or panic breakaway.
- 1.7. Check that a 115 volt, single phase, 60 Hz, fused, 15 amp, 3-wire power supply is available at the side jamb with approximately 12" of wire available to connect to the operator. UL approved type flexible conduit is recommended for the 115 volt power line.

The 115 volt power supply must be a dedicated circuit from the main circuit breaker panel and **must not** be connected into a building lighting system operating fluorescent lights.

For concealed applications, continue with "2. Concealed Header Installation" (page 5).

For surface applications, continue with "3. Surface Header Installation" (page 6).

2. CONCEALED HEADER INSTALLATION



NOTE

Install **concealed application** headers so there is 1/8" between the bottom of the header and the top of the door.

2.1. Prepare jamb tubes:

Factory supplied jamb tubes: Factory supplied jamb tubes are already prepared for header installation, and Riv-nuts are already installed in the jamb tubes.

Existing jamb tubes: Prepare existing jamb tubes using template 81306-684, then install four 1/4-20 Riv-nuts inside each jamb tube.

2.2. Align the header with the jamb tubes. For headers with a single operator, position the end of the header containing the operator brackets near the pivot side of the opening (Figure 2-1). Secure the header to the jamb tubes with four 1/4-20 hex head screws at each end (Figure 2-2).

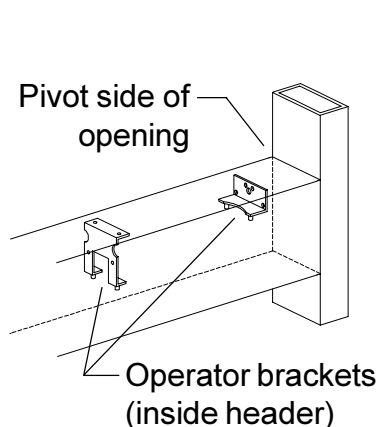

Figure 2-1

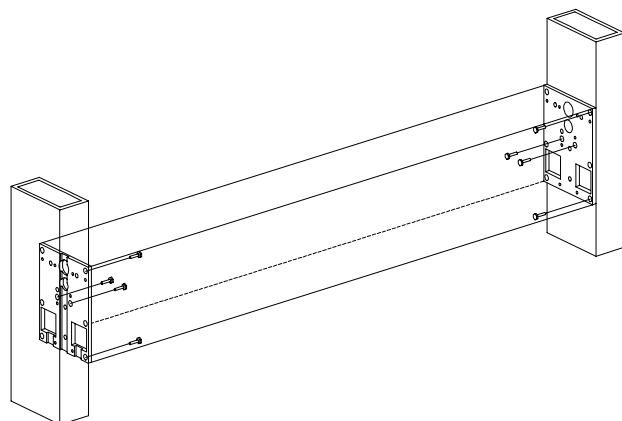

Figure 2-2

2.3. Stand the header/jamb tube assembly in the opening.

2.4. Feed the 115 volt power conduit into the header (Figure 2-3). Leave 12" minimum of wire inside the header for final hookup.

2.5. Shim and square the side jamb tubes in position, then secure the jamb tubes in the opening.

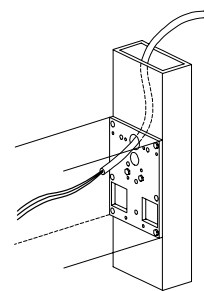

Figure 2-3

Continue with “4. AC Power and Ground Wiring” (page 8).

3. SURFACE HEADER INSTALLATION

- 3.1. For a header with two operators (for a simultaneously operated pair of doors), designate one end of the header as the slave operator end. (It does not matter which end is the slave operator end.)
- 3.2. Refer to Figure 3-1 and step 3.3 and prepare wire access holes appropriate for the application in the header using template 91194-684. Be sure to position edge "A" of template 91194-684 as shown in Figure 3-1.

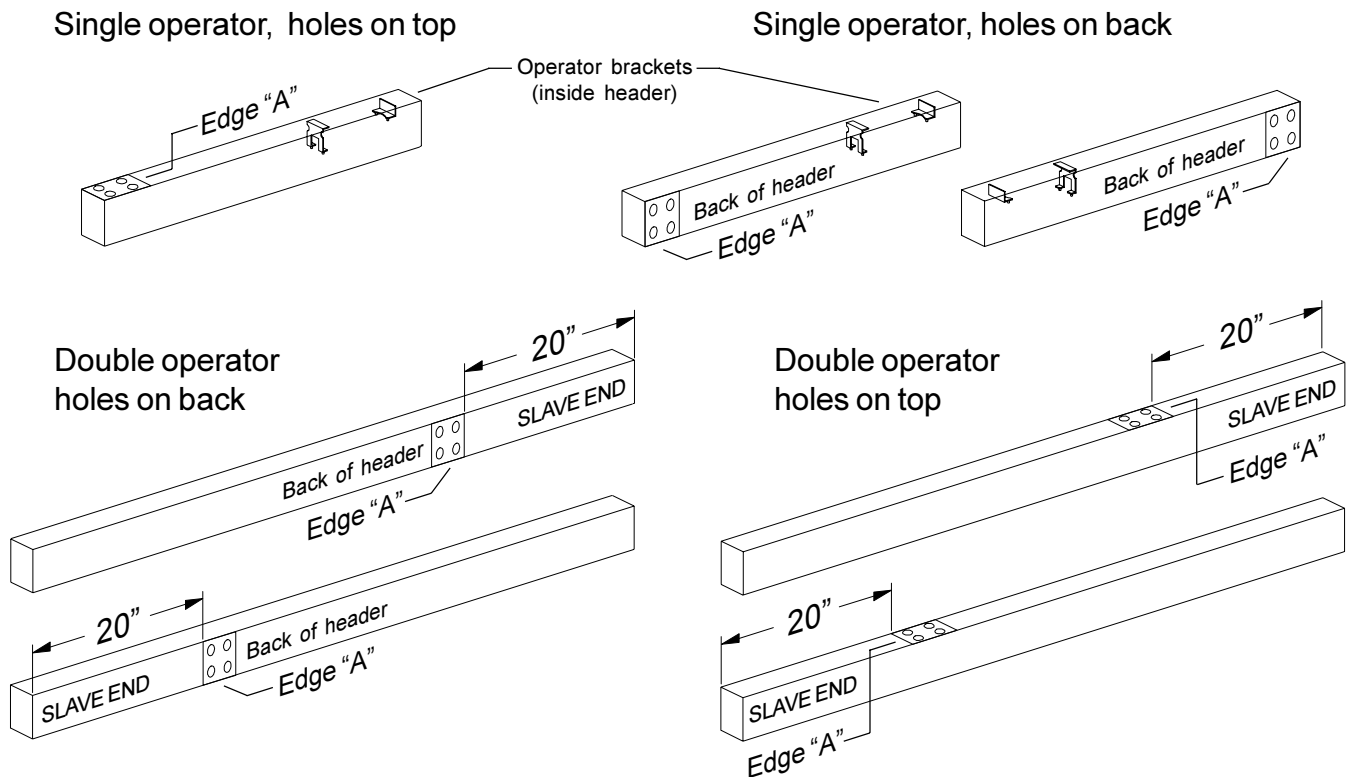

Figure 3-1

- 3.3. Install horizontal mounting brackets on the header per the instructions supplied with the brackets (Figure 3-2). Make sure the horizontal mounting brackets are oriented so the wire access holes in the header (see step 3.2) face up or face the door and, for single operator headers, the operator brackets inside the header are near the hinge side of the opening.

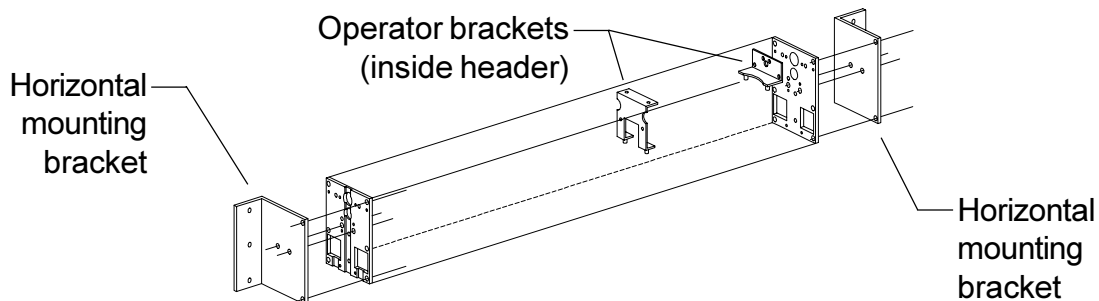

Figure 3-2

3. SURFACE HEADER INSTALLATION (continued)



NOTE

Install **surface application** headers so there is 1" between the bottom of the header and the top of the door.

- 3.4. Install the header with horizontal mounting brackets to the jambs per the instructions supplied with the horizontal mounting brackets (Figure 3-3).

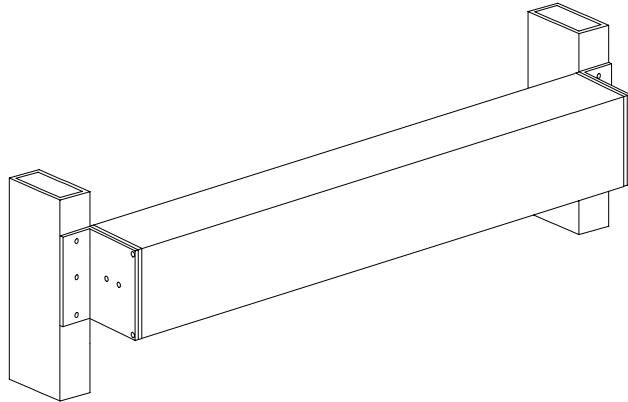

Figure 3-3

- 3.5. Feed the 115 volt power conduit into the header (Figure 3-4). Leave 12" minimum of wire inside the header for final hookup.

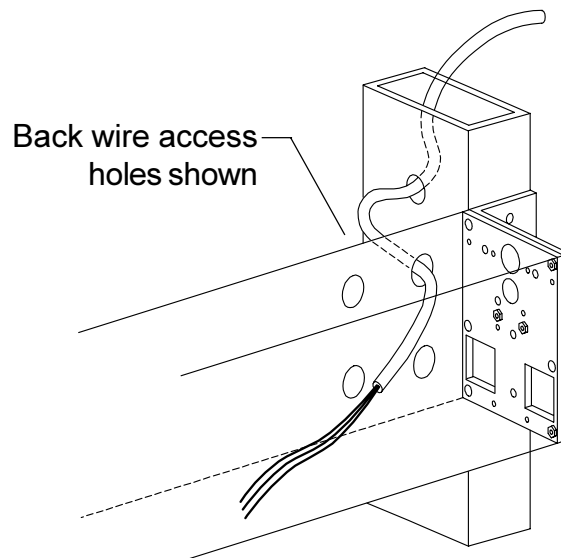

Figure 3-4

Continue with "4. AC Power and Ground Wiring" (page 8).

4. AC POWER AND GROUND WIRING

- 4.1. Connect the 115 volt power hot and neutral wires to the power supply wire harness 81275-000 as shown in Figure 4-1.

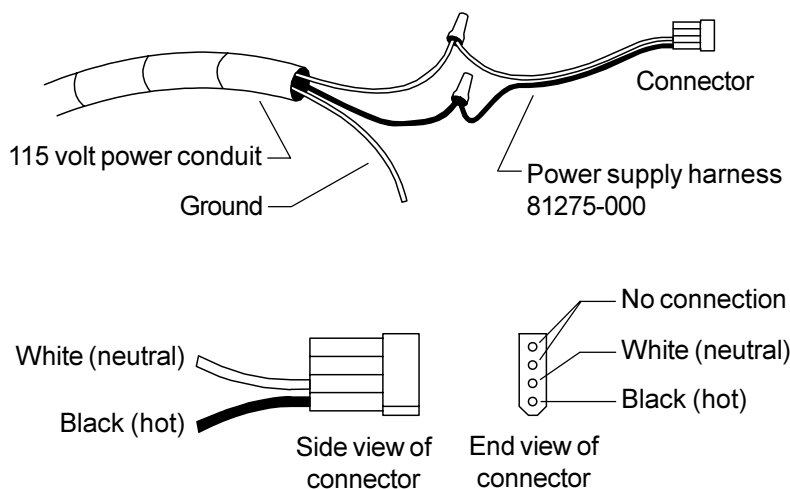

Figure 4-1

- 4.2. Connect the 115 volt power ground wire to the header end plate where shown in Figure 4-2.
- 4.3. Connect the control box ground wire 85009-600 to the header end plate where shown in Figure 4-2. Do not connect the other end of this wire at this time.

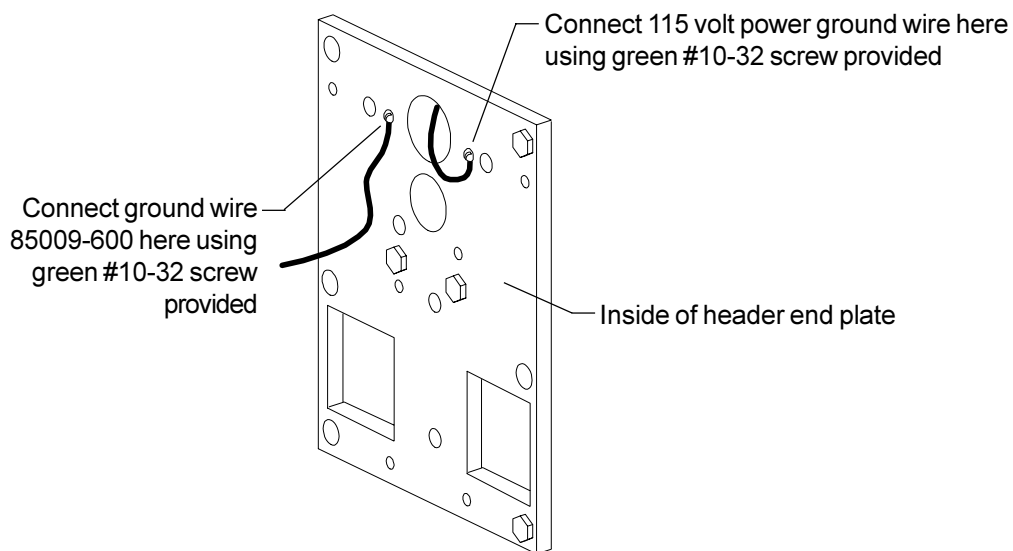

Figure 4-2

Continue with "5. Operator Installation" (page 9).

5. OPERATOR INSTALLATION

- 5.1. For double operator systems with differently handed operators, make sure that the correct operator is installed in each end of the header. The handing of the operator (R.H. or L.H.) is indicated on a label on the operator.
- 5.2. For ease of installation, disconnect the green operator ground wire 85010-600 from the operator and connect the other end of this wire to the rear operator mounting bracket in the header (Figure 5-1).
- 5.3. Check that there is a rubber grommet inside each of four mounting holes on the operator (Figure 5-2).
- 5.4. Line up the four mounting holes on the operator with the four mounting studs on the operator brackets (Figure 5-3). Make sure that the operator cable (with 6-pin connector) is hanging down freely and push the operator up onto the mounting studs. Make sure cables are not pinched when operator is installed. (The mounting studs fit snugly into the grommets, and firm pressure may be required to get the operator into position.)
- 5.5. Secure the operator to the header using four 5/16-18 hex head screws and washers (Figure 5-3). Tighten the screws until they make contact with the mounting studs on the operator brackets.
- 5.6. Reconnect to the operator the green ground wire that was disconnected from the operator in step 5.2 (Figure 5-3).
- 5.7. For a header with two operators, install the second operator in the same manner.

For center pivoted doors, continue with “6. Pivot Block Installation” (page 10).

For other doors, continue with “8. Control Box Installation” (page 12).

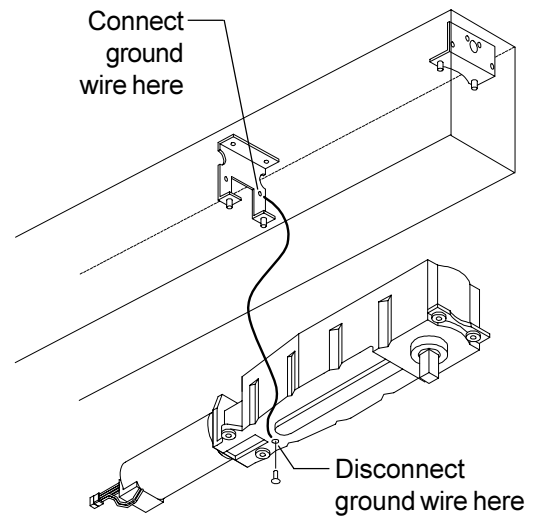

Figure 5-1

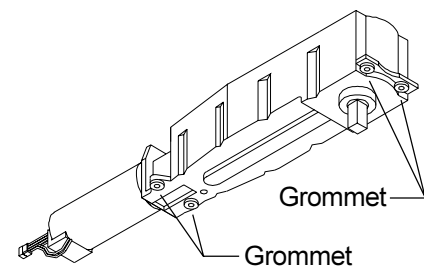

Figure 5-2

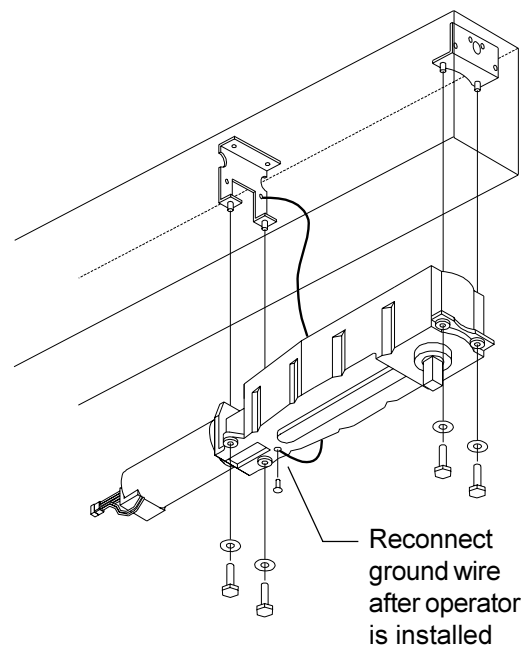

Figure 5-3

6. PIVOT BLOCK INSTALLATION



NOTE

This section is applicable ONLY if using the Dor-O-Matic supplied lower pivot block (with pivot post attached) on center pivoted, interior doors. If not being used, continue with "7. Breakaway or Fixed Stop Installation" (page 11).

- 6.1. Position the lower pivot block (Figure 6-1) as shown in Figure 6-2 oriented so the pivot post is 2-3/4" or 3-3/4" (nominal) from the jamb, as necessary.
- 6.2. Use the pivot block as a guide and mark and prepare four mounting holes for appropriate fasteners for the mounting surface.
- 6.3. Secure the pivot block in place with appropriate fasteners (Figure 6-3).

Continue with "7. Breakaway or Fixed Stop Installation" (page 11).

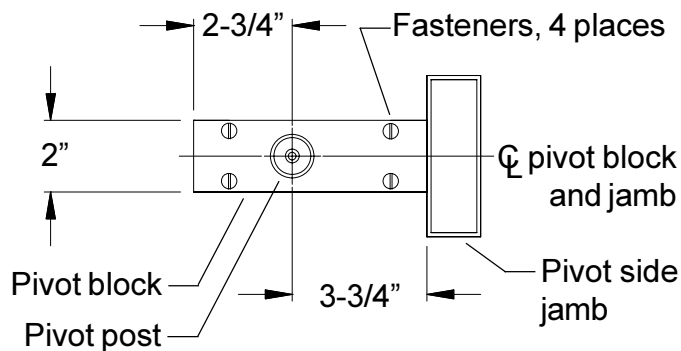

NOTE

Pivot block shown installed for a door with a 3-3/4" mounting point. For 2-3/4" mounting point, reverse pivot.

Figure 6-1. Top view of lower pivot block.

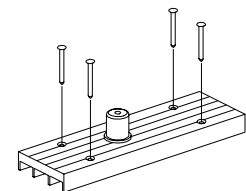
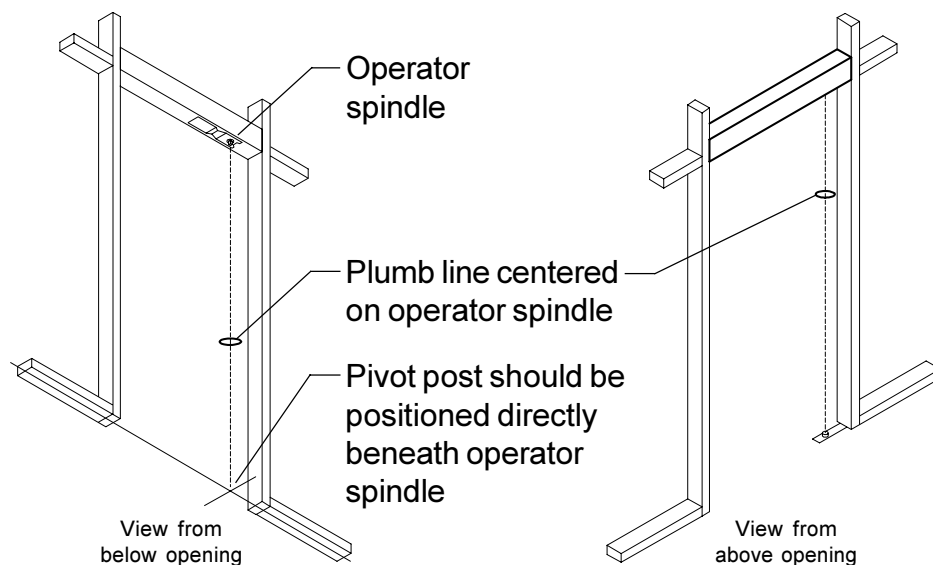

Figure 6-3

Figure 6-2

7. BREAKAWAY OR FIXED STOP INSTALLATION



NOTE

This section is applicable **ONLY** to center pivoted doors using the Dor-O-Matic supplied breakaway or fixed stop. If not being used, continue with “8. Control Box Installation” (page 12).

Breakaway and Fixed Stop Operation

The function of the breakaway or fixed stop is to act as a mechanical stop on an inswinging door so the door cannot normally be opened in the outswinging direction.

The **breakaway stop** differs from the fixed stop in that, in a panic or fire condition, when approximately 50 lbs. of force is applied on the door from the inswinging side, the door will open in the outswinging direction. When this occurs, a switch in the breakaway stop disables the automatic operation of the door. The door then remains inoperative and in the breakaway position until it is manually pushed back through the opening to the inswinging side. This action resets the breakaway stop and restores automatic operation.

- 7.1. Orient the breakaway stop according to the directions on the switch label (Figure 7-1). The “OPENING DIRECTION OF DOOR” arrow should point in the direction that the door opens during normal operation.

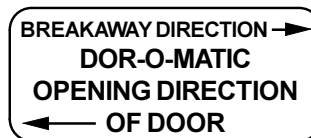

Figure 7-1

- 7.2. Install the breakaway or fixed stop inside the header approximately 2-1/4” from the latch end using the four #8-32 x 3/4” screws supplied with the stop (Figure 7-2). Mounting holes for the stop have been prepared in the header at the factory.

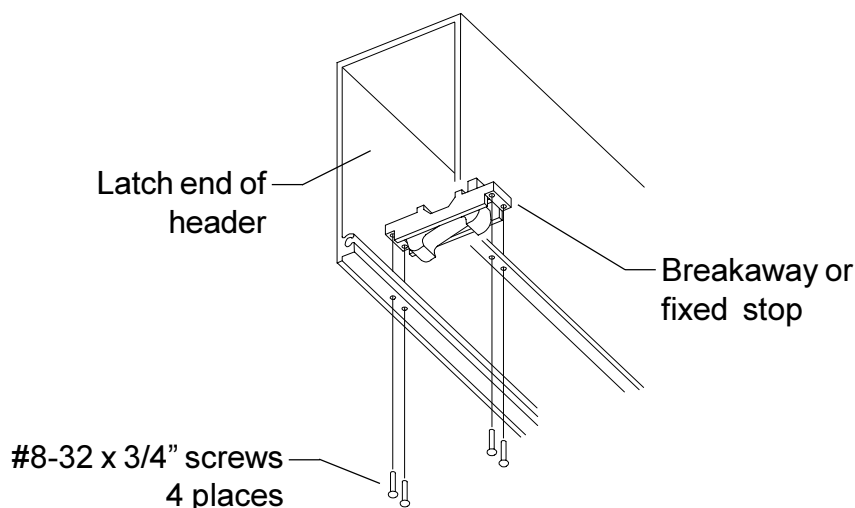

Figure 7-2

Continue with “8. Control Box Installation” (page 12).

8. CONTROL BOX INSTALLATION

- 8.1. Orient the control box so the switches face down and the 6-pin Molex connector faces the operator for a single system or the master operator for a double system (Figure 8-1).
 - 8.2. Raise the control box into the header and rotate the two mounting bars so they engage the slots that run the length of the header (Figure 8-2).
 - 8.3. See Figure 8-3 for final positions of operator(s) and control box inside the header.
- Continue with “9. Control Box Wiring” (page 13).**

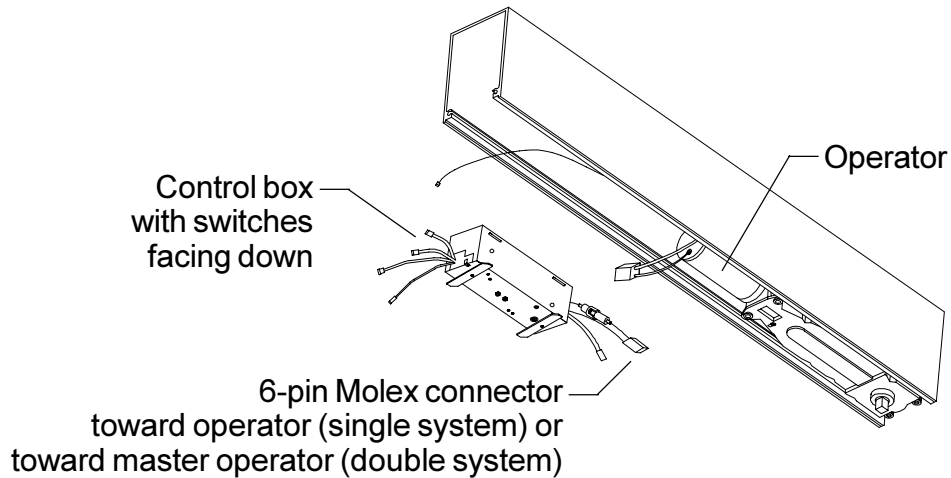

Figure 8-1

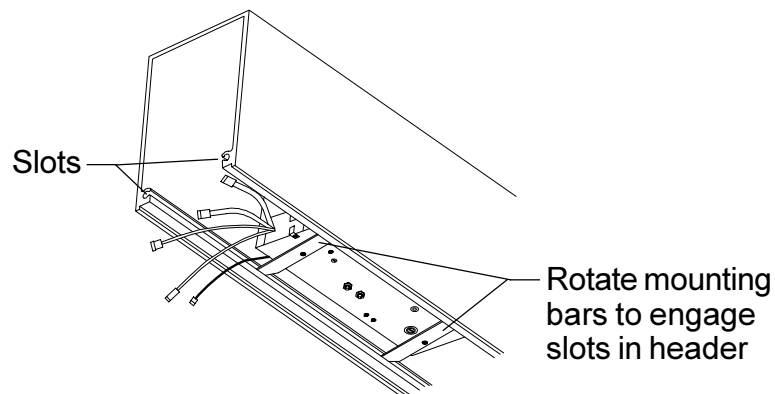
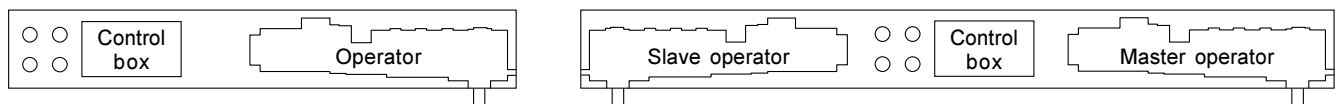

Figure 8-2



Views from front of header,
wire access holes shown on back of header

Figure 8-3

9. CONTROL BOX WIRING



CAUTION

High voltage wiring must be separated from low voltage wiring by using UL listed wiring for the control box, operators, and low voltage accessories.



CAUTION

When joining or separating a Molex plug and receptacle, do not push or pull on any of the wires. This may cause a wire to be pulled loose from a terminal, which may result in a malfunction.

- 9.1. Connect the control box to the motor/gearbox operator by gently dressing the motor wiring harness and 85398-000 or 85398-090 into an “S” shape over the motor and connecting the 6-pin Molex connectors.
- 9.2. Connect the control box ground wire 85009-600 (already attached to the header end plate) to the spade terminal on the control box chassis (Figure 9-1).
- 9.3. Connect the four remaining connectors (see Figure 9-2 for a single operator or Figure 9-3 for a double operator). The arrangement of the plugs and receptacles prevents incorrect joining.
- 9.4. Dress all wires neatly together. Use the stick-on cord-clips 81314-600 to retain wires in their proper locations and add cord-clips on both sides of the fuse holders to prevent shifting.

For center pivoted doors, continue with “10. Finger Guard Installation” (page 16).

For other doors, continue with “12. Push, Pull, and Offset Arm Installation” (page 19).

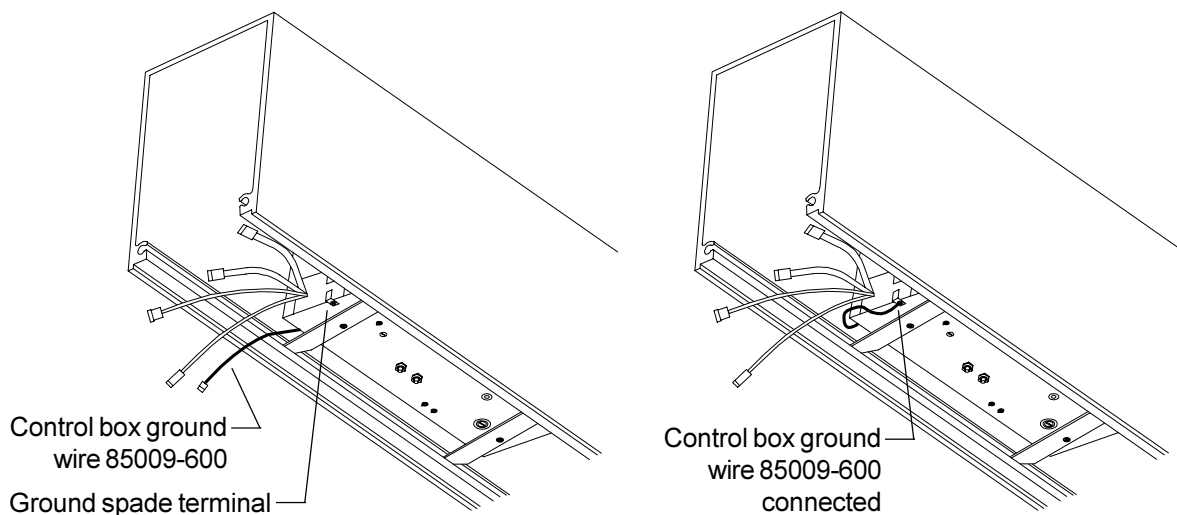

Figure 9-1

SINGLE OPERATOR WIRING

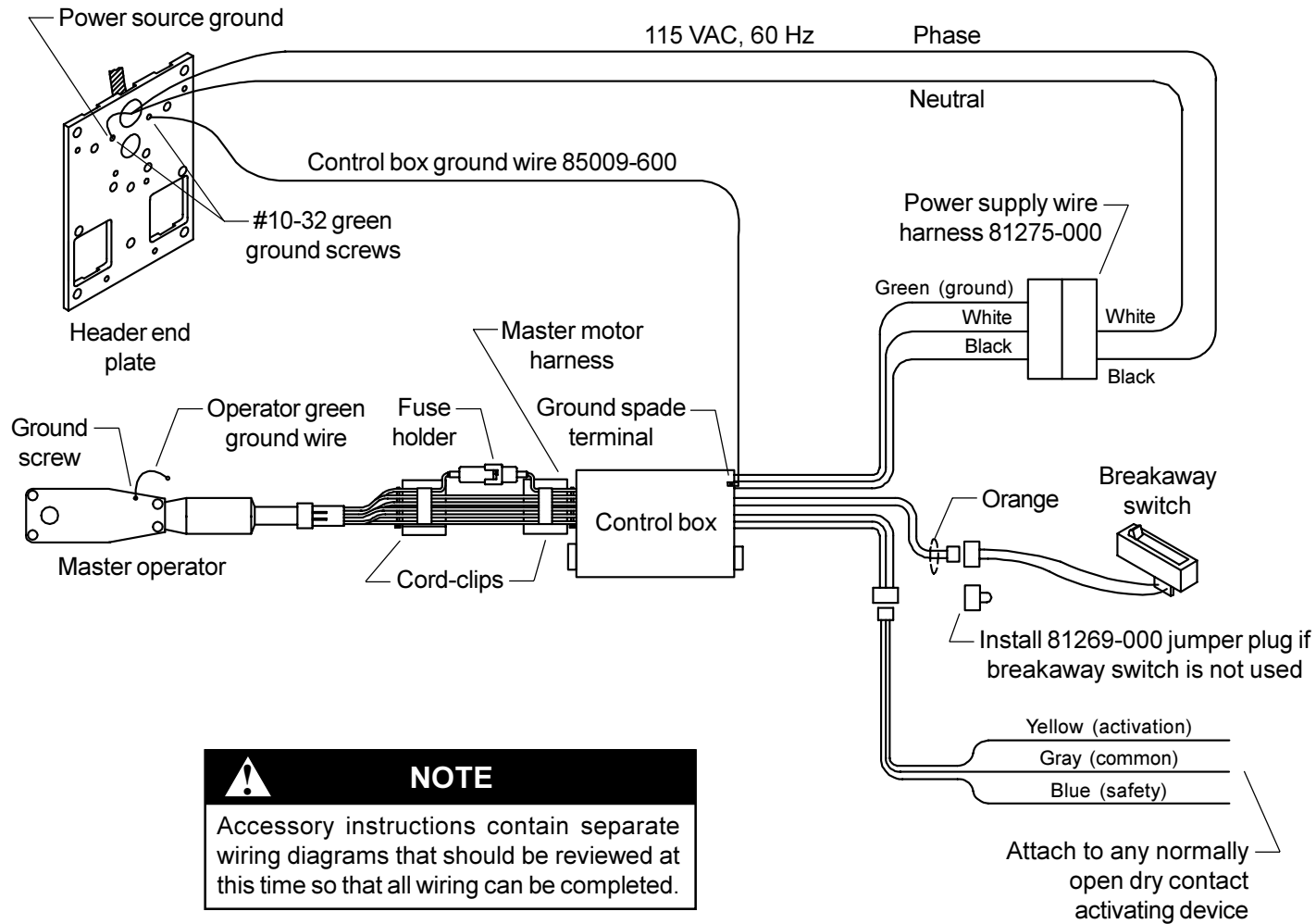
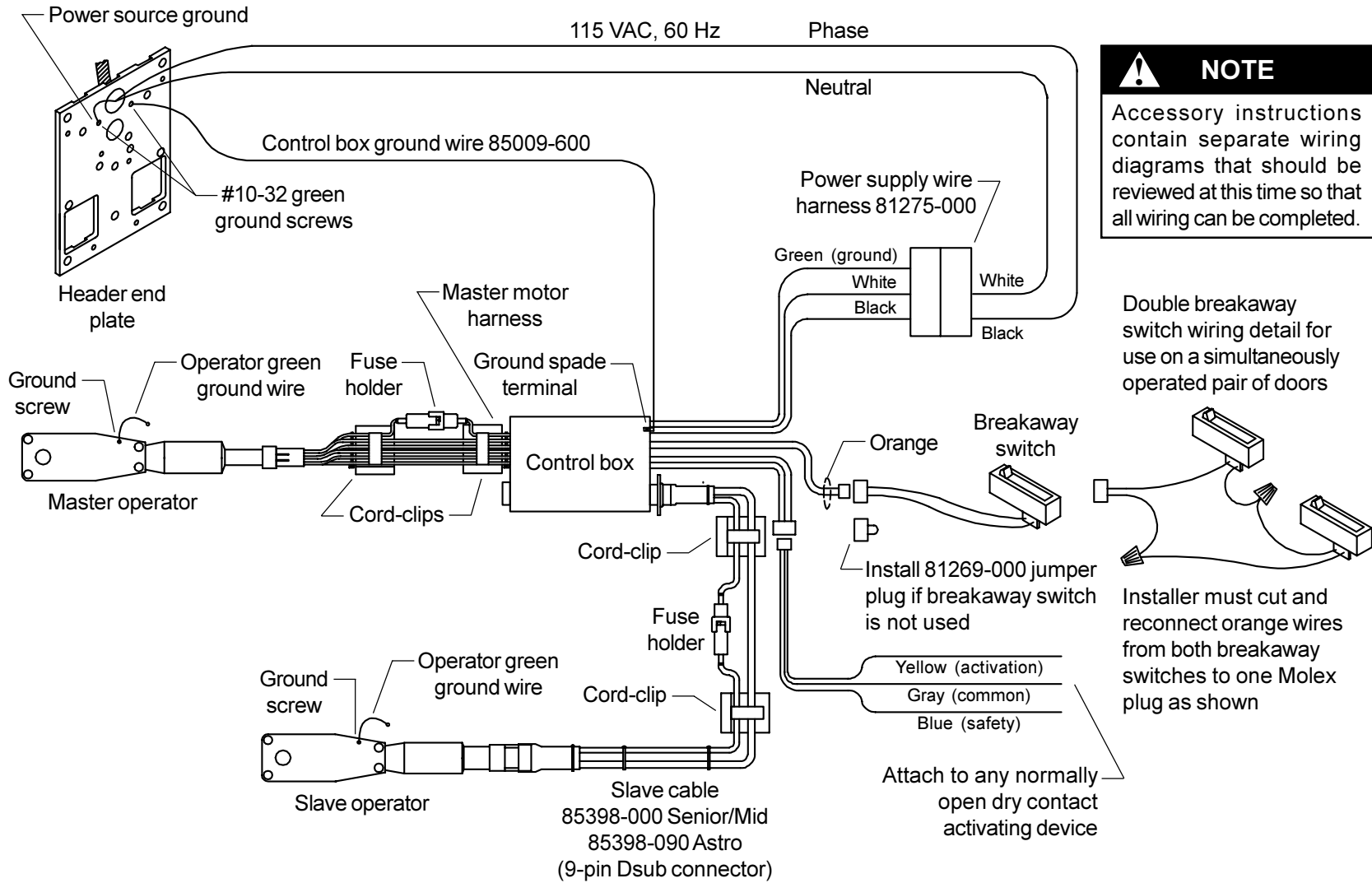

Figure 9-2

DOUBLE OPERATOR WIRING



NOTE
 Accessory instructions contain separate wiring diagrams that should be reviewed at this time so that all wiring can be completed.

Double breakaway switch wiring detail for use on a simultaneously operated pair of doors

Installer must cut and reconnect orange wires from both breakaway switches to one Molex plug as shown

Attach to any normally open dry contact activating device

Figure 9-3

10. FINGER GUARD INSTALLATION



NOTE

This section is applicable **ONLY** to center pivoted doors using the Dor-O-Matic supplied finger guard. If not being used, continue with “11. Center Pivoted Door and Arm Installation” (page 17).

- 10.1. Scribe a line down the center of the pivot side door jamb (Figure 10-1).
- 10.2. If necessary, cut down the finger guard to fit the installation.
- 10.3. Align the center of the finger guard over the scribed line. Use the screw holes in the finger guard as guides to locate the mounting holes, and drill #21 (0.159” dia.) mounting holes in the door jamb.
- 10.4. Secure the finger guard to the door jamb with #10 self-threading screws.
- 10.5. Make sure there is one mounting screw approximately 1” from each end of the finger guard. If necessary, drill additional mounting holes in the finger guard and door jamb in these locations and install #10 self-threading screws.

Continue with “11. Center Pivoted Door and Arm Installation” (page 17).

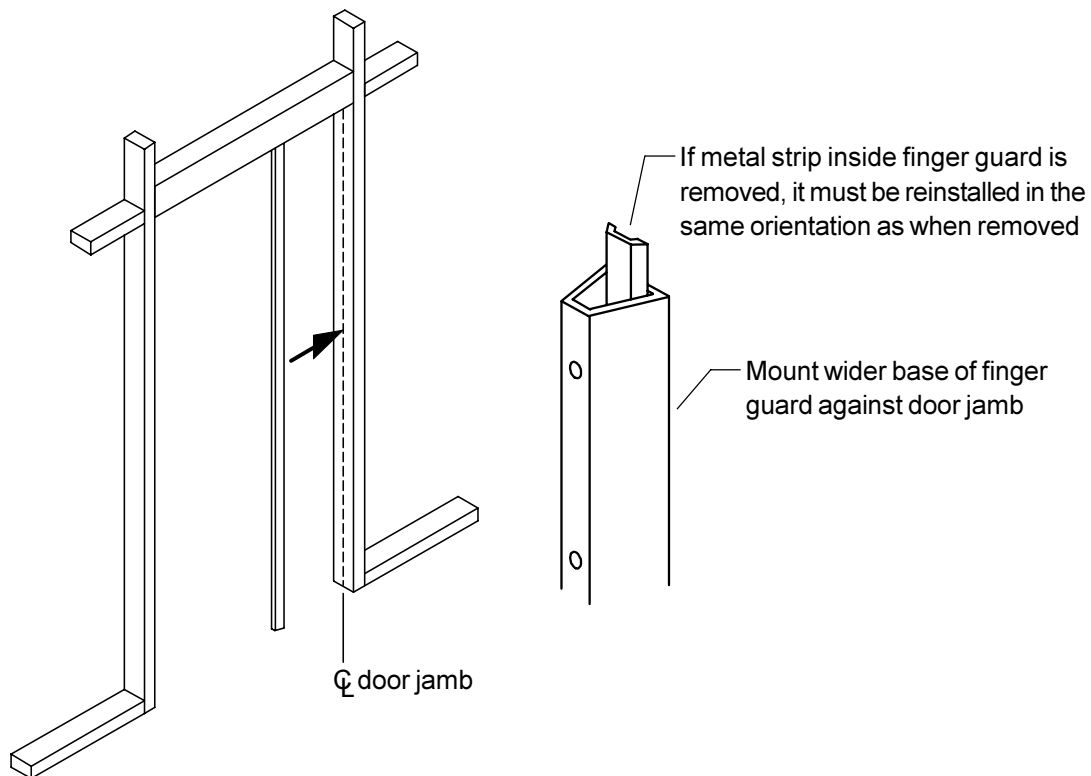

Figure 10-1

11. CENTER PIVOTED DOOR AND ARM INSTALLATION

- 11.1. Doors manufactured by Dor-O-Matic are factory prepared for all required hardware. If another type of door is being used, prepare it per template 880-I (available from factory).
- 11.2. For center pivoted doors, install top arm attachment bar and bottom pivot assembly using screws supplied with those components (Figure 11-1).

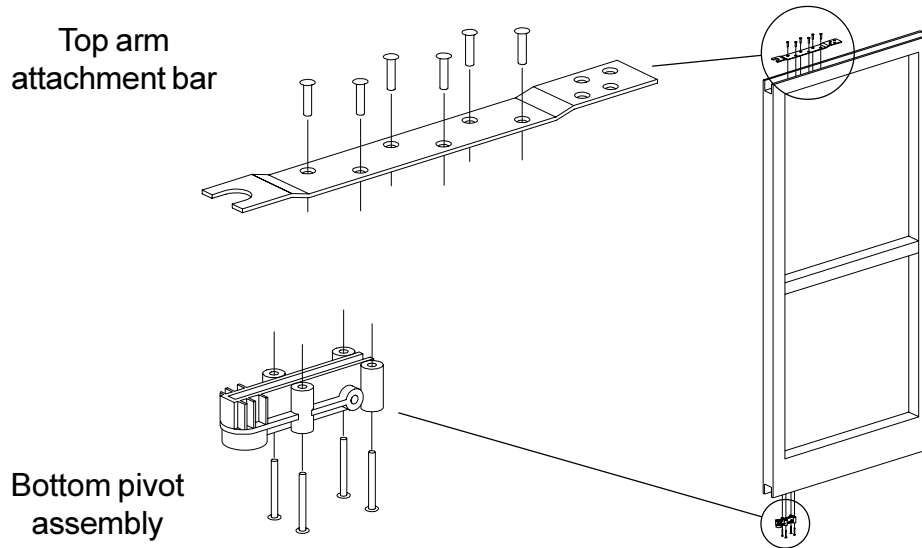

Figure 11-1

- 11.3. The operator is shipped from the factory with the spindle in the breakout position, so the arm must be oriented in the breakout position when installed on the spindle. Before installing the arm, determine the arm breakout position (Figure 11-2).
- 11.4. Orient the arm in the breakout position and press the arm onto the spindle until the end of the spindle is flush with the bottom surface of the arm, then tighten the Allen head cap screw on the arm (Figure 11-3).

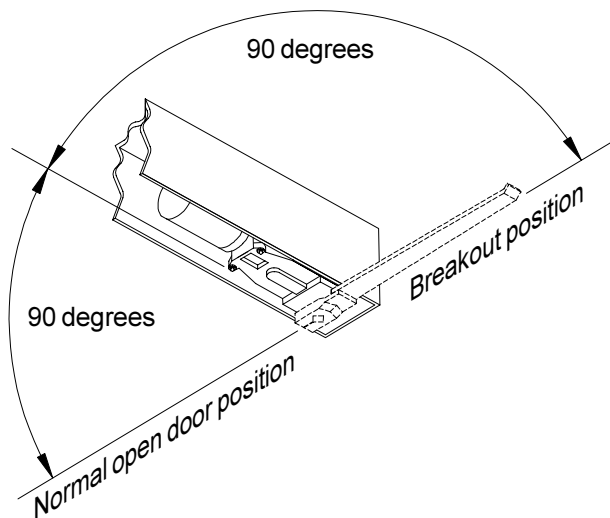

Figure 11-2

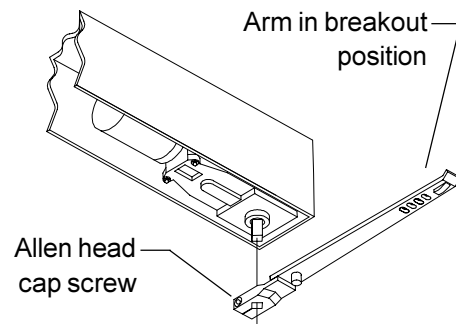

Figure 11-3

11. CENTER PIVOTED DOOR AND ARM INSTALLATION (continued)

11.5. Position the door so the arm is in the top channel of the door and gently slide the door up against the lower pivot (Figure 11-4).

11.6. Lift the door slightly and push back until the bottom pivot locks into place.

11.7. Raise the nose of the door and push back until the top arm snaps into place.

11.8. Align the door in the open position (perpendicular to the opening).

11.9. Install two 1/4-20 x 1/2" hex head cap screws and washers through two of the oval holes in the arm and into the top attachment arm (Figure 11-5). Install screws in whichever of the positions shown align with the door in the open position (perpendicular to the opening).

11.10. Check door operation by pushing door to normal closed position, continue pushing through breakaway stop to 90 degree open position, and then release door. Door should close.

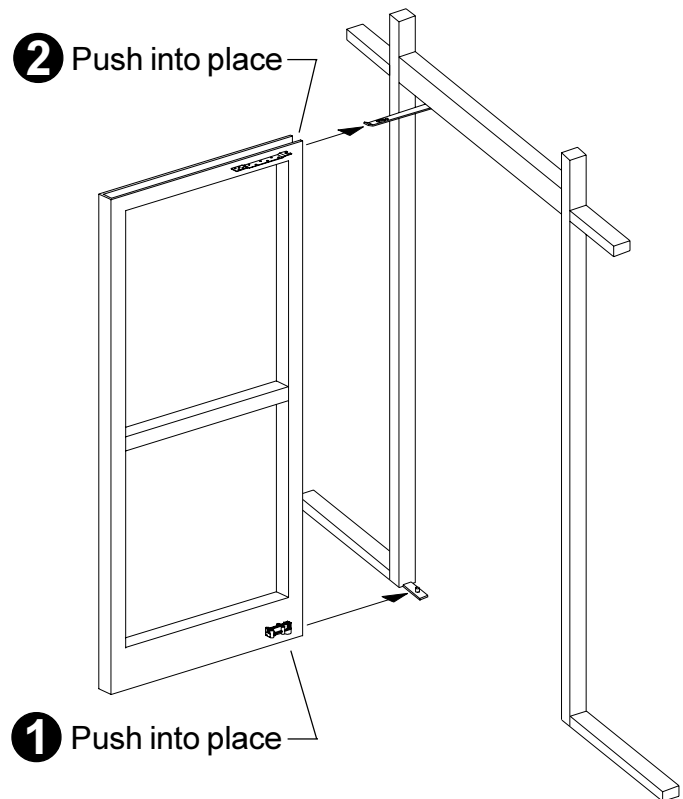

Figure 11-4

CAUTION
If the operator is not connected to the control box, the door will slam closed when released.

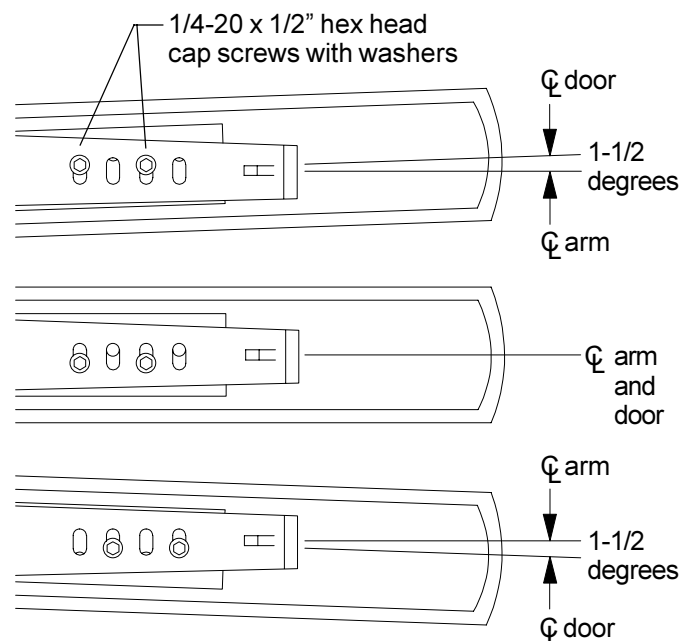
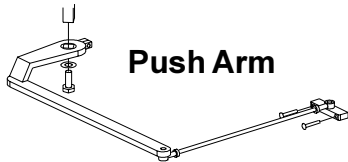

Figure 11-5

Continue with "13. "Glazing," (page 19).

12. PUSH, PULL, AND OFFSET ARM INSTALLATION

Push Arm: For surface header applications.
To install, see separate instructions for
81460-9XX Push Arm & Link Assembly.



Pull Arm: For surface header applications.
To install, see separate instructions for
81470-9XX Pull Arm Assembly.

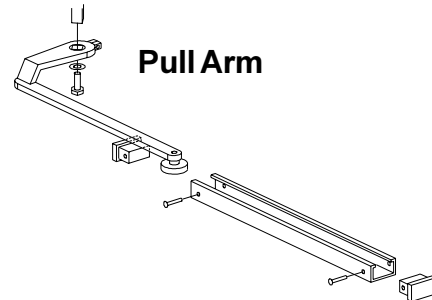

Offset Arm: For concealed header applications with butt hung and offset pivoted doors. To install:

1. Prepare door and install slide channel (see separate Installation Instructions for 87400-XXX Arm).
2. Note position of operator spindle. Turn on operator power. Momentarily short activation wires so spindle slowly rotates toward full open position and stops. Continue doing this until spindle reaches full open position (refer to Figure 11-2), then join activation wires together with a wire nut.
3. Insert arm slide into slide channel, slide arm onto spindle, and tighten arm Allen head cap screw.
4. Remove wire nut from activation wires; turn off power.

Continue with "13. Glazing."

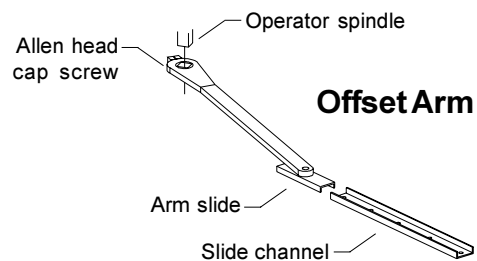

13. GLAZING



CAUTION

Glazing material must comply with the ANSI standard specification.



CAUTION

Operator speed adjustments cannot be set properly until after the door is glazed.

Continue with "14. Control Box Functions."

14. CONTROL BOX FUNCTIONS

Refer to separate control box instructions supplied with the control box to set control box functions.

Continue with "15. Header Dress Plate Installation" (page 20).

15. HEADER DRESS PLATE INSTALLATION

- 15.1. For concealed header applications using offset arm with butt hung and offset pivoted doors **only**, prepare header dress plates for concealing channel (Figure 15-1; see separate Installation Instructions for 87400-XXX Arm).
- 15.2. Install spindle plate and filler plate (Figure 15-2). Spindle plate cutout fits over operator spindle.
- 15.3. For concealed header applications using offset arm with butt hung and offset pivoted doors **only**, install concealing channel (Figure 15-1).

Continue with “16. “Release for Service.”

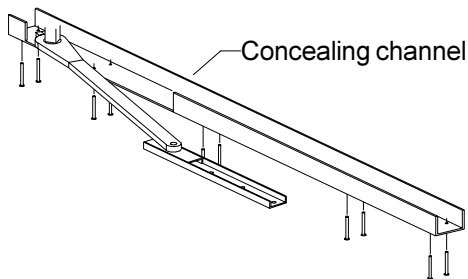

Figure 15-1

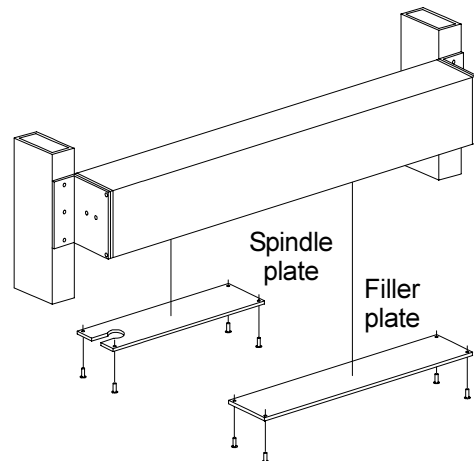

Figure 15-2

16. RELEASE FOR SERVICE

- 16.1. Remove all tools, installation equipment, and debris from the vicinity of the door.
- 16.2. Install all safety, traffic control, and instruction decals on the door as required by the latest revision of ANSI/BHMA A156.10 for the Astro or A156.19 for the Senior/Mid-Swing. **This is very important! Failure to do this leaves the installer LIABLE for any accident that might occur. This must be done!**
- 16.3. Verbally instruct the owner or person in charge of the proper operation of the door.
- 16.4. Instruct the owner or person in charge to routinely inspect the door for occasional damage, developing problems, minor preventive maintenance.
- 16.5. Instruct the owner or person in charge who and where to call for service when required.



IMPORTANT

Make sure to install all safety, traffic control, and instruction decals on the door as required.



Mid-Swing™ Universal Control Box

Instruction Manual 85455-900 Universal Control Box

Factory Authorized Door Leaf Size & Weight:		
<u>Type</u>	<u>Width per Leaf</u>	<u>Max. Weight per Leaf</u>
Single Door	36" to 48"	200 lb.
Simultaneous Pair	30" to 48"	200 lb.

DOR-O-MATIC®

7350 W. Wilson Ave.
Harwood Heights, IL 60706

Toll Free: 1-800-543-4635
In Illinois: 708-867-7400
Automatic Sales FAX: 708-867-0291
Engineering FAX: 708-867-1177

www.doromatic.com

DA - 299

INDEX

Mid-Swing

85455-900 Universal Control Box Manual

<u>TITLE</u>	<u>PAGE</u>
COVER PAGE.....	1
INDEX.....	2
GENERAL.....	3
IMPORTANT INFORMATION	
PART IDENTIFICATION.....	4
CONTROL BOX SETTINGS AND ADJUSTMENT.....	5-6
Operational Check And Adjustment	
Operational Walk Throught Test	
FUNCTION AND LATCH LABEL.....	7
FUNCTION AND LATCH LABEL DESCRIPTION.....	7-9
DEVICES	9

GENERAL

The NEW Mid-Swing Universal Control Box 85455-900 is the replacement for the Mid-Swing Universal Control Box 85450-900. The 85455-900 physically looks exactly the same as the 85450-900, and operates almost identically to the 85450-900. The main differences are as follows:

1. The original red and black wires and 2 pin Molex plug for the slave door have been removed.
2. We have added an additional 9 pin Logic plug connector on the input side of the control box for the new #85398-000 slave cable. Note: **DO NOT** connect anything else to this connector.
3. The circuit breaker was removed from the control box and fuse holder/fuse was added to the master and slave (#85398-000) wiring harness to provide motor protection. In case of an overload on either of the motors, the fuse will blow to protect the motor. In order to restore the operation back to normal, the fuse must be replaced with the exact same type and rating.

To provide reliable operation of the slave door on simultaneous pairs, the control is now reading the direction and movement of the slave door with the Hall effect counter. Use the new #85398-600 slave cable when replacing existing control boxes on simultaneous pairs of doors.

The #85455-900 is the most diversified control box ever offered, and may be used to replace almost all previous generations of Mid-Swing control boxes.

IMPORTANT INFORMATION

- Note: #85455-900 “Universal” control boxes have a 15-pin logic plug and a 9-pin logic plug. If you are replacing a box with a 9-pin logic plug and you have switches or other devices that plug into the 9-pin logic plug, those switches or devices must also be replaced. Do not plug any accessory switches into the 9-pin slave plug on the 85455-900 control box.

PART IDENTIFICATION

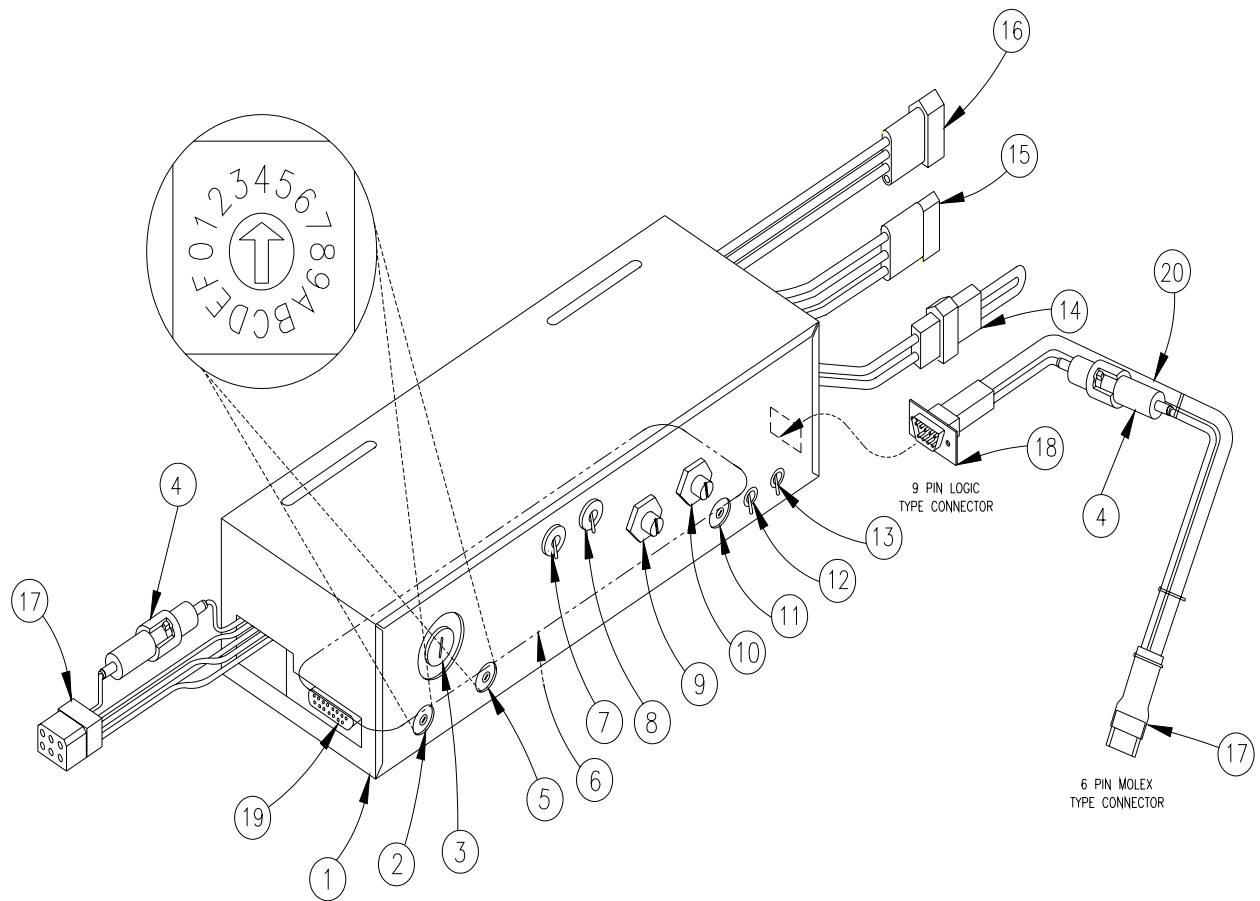

- | | |
|---|---|
| ① CONTROL BOX # 85455-900/-400 115 Volt | ⑫ OPENING SPEED ADJUSTMENT
(#1 FAST, #2 MEDIUM, #3 SLOW) |
| ② FUNCTION SELECTOR DIAL | ⑬ BACKCHECK SPEED ADJUSTMENT
(#1 - ONE DOOR, #2 - TWO DOORS) |
| ③ FUSE, #771018-600 3A | ⑭ 2-PINS FEMALE FOR BREAKAWAY SWITCH |
| ④ FUSE HOLDER, WITH FUSE
#70626-600 .75A | ⑮ 3-PINS FEMALE, ACTIVATION |
| ⑤ LATCH SELECTOR DIAL | ⑯ 4-PINS MALE, POWER INPUT |
| ⑥ LABEL FOR FUNCTION & LATCH SELECTOR DIALS
(LOCATED ON BOTTOM OF BOX) | ⑰ 6-PINS FEMALE, TO MASTER OPERATOR |
| ⑦ PUSH-N-GO ON/OFF SWITCH | ⑱ 9-PINS FEMALE, TO SLAVE OPERATOR (NEW) |
| ⑧ POWER BOOST ON/OFF SWITCH | ⑲ LOGIC TERMINAL-USED FOR ACCESSORIES (15-PINS) |
| ⑨ CLOSING SPEED ADJUSTMENT (FOR MASTER UNIT) | ⑳ SLAVE CABLE #85398-000 |
| ⑩ CLOSING SPEED ADJUSTMENT (FOR SLAVE UNIT) | |
| ⑪ TIME DELAY ADJUSTMENT (1 1/2 SEC. TO 30 SEC.) | |

Figure 1: Mid-Swing 85455-900 Universal Control Box

CONTROL BOX SETTING AND ADJUSTMENT

1. Operational Check and Adjustments:

- A. Set opening speed switch to position #3, (Slow).
- B. Set back check speed switch to position #1, (One Door).
- C. Adjust time delay potentiometer approximately 1/8 turn up from minimum.
- D. Turn the power on to the operator. After the first activation signal, the door must be allowed to fully open and close one time, after which it is ready for normal operation.
- E. Opening Speed Adjustment:
 - 1. Opening speed is adjusted by a three position toggle switch, marked 1,2,3: #1 Fast; #2 Medium; #3 Slow. These are pre-set speeds, but allow proper adjustment for any normal weight and size door.
 - 2. Cycle the door open and closed several times and observe the opening speed. Select a switch position setting that gives desired opening speed.

NOTE: It is recommended that the door be operated as slow as is practical for the traffic conditions.

F. Back Check Position:

There is no adjustment available on the back check position, because it is set automatically while the door sizes itself.

G. Back Check Speed Adjustment:

- 1. The back check speed is controlled by a two position toggle switch marked #1-One Door and #2-Two Doors.
- 2. For any size single door, the switch should be set to position #1.
- 3. For a simultaneous pair of doors, the switch should be set in position #2.

H. Closing Speed Adjustment:

- 1. Continue to cycle the door open and closed while making adjustments.
- 2. You will notice there are two closing speed adjustment potentiometers, one marked "Master" and one marked "Slave". On simultaneous pairs of doors, each leaf can be adjusted separately, allowing both doors to close fully and simultaneously.
- 3. On a single door, only the Master potentiometer is used to adjust closing speed. The Slave control has no effect.

I. Latch Position:

The latch rotary selector switch, is used to change the position where the latch occurs (0 to 23 degrees from the fully closed position). The latch selector settings are marked 0 through 7 on the rotary dial located on the control box. Adjustments are made using a small screwdriver. Setting zero selects no latch occurring at all, whereas setting 7 selects latch occurring at 23 degrees from the fully closed position. Setting 4 selects the standard latch of 13 degrees from fully closed position. Dial the latch setting to the position required by the environment into which the door was installed.

J. Latching speed:

Latching speed is factory set and has no adjustment.

K. Time Delay Adjustment:

1. to meet ANSI/BHMA A156.19 Standard, the total time delay, including any delay in the activation and safety devices, must be adjusted to hold the door open for a minimum of 5.0 seconds after both activation and safety zones are clear.
2. Increase the time delay period by turning the TIME DELAY knob (potentiometer) clockwise. The total adjustment range on the control box itself is 1 to 30 seconds of time delay.

L. Power boost close and power boost hold features:

1. This is a built-in feature that can be turned on or off with a two position toggle switch.
2. It is used to electronically increase the closing force of the door from 9 lbs. to 18 lbs. in order to close and hold the door closed against high winds or high stack pressure.
3. When the power boost close and hold feature is turned on, the automatic increase in power occurs approximately 7 seconds after the door has closed to the latch position. The power boost feature will not turn on during the closing door travel.
4. Power boost is non-functional on a Mid-Swing control box

2. Operational Walk through Test:

NOTE: It is assumed that during the installation process, any problems would have been found and corrected before this point. However, it is recommended that a complete walk-through test now be performed.

- A. Opening and holding function: Normally walk up to the door and step into the activating area. The door should open smoothly and silently to the backcheck point, where it should slow down rapidly and drift into full 90 degrees open without slamming.
- B. Remain standing in the activating area for a while, making sure that the door does not time out and close while being activated.
- C. If a safety device is installed, walk on through the doorway and into the safety area, remain in the safety area making sure that the door does not close while the safety area is occupied.
- D. Step out of the safety area and when both the activating and the safety areas are clear, the door should time out at the pre-set time delay period. The door should then close quietly and smoothly to the latch point, where it rapidly slows down and slowly drifts into the fully closed position without slamming.
- E. Safety Function with the Door Closed: If a safety device is installed, step back into the safety area, and have someone else step into the activating area. The door must not open.
- F. Step out of the safety area and the door should open fully. Have the other person step out of the activating area. The door should stand open until the end of the time delay cycle, and then close as before.

FUNCTION AND LATCH LABEL

MID-SWING UNIVERSAL CONTROL BOX			
SETTING	FUNCTION SELECTOR DIAL	SETTING	LATCH SELECTOR DIAL
*0	77700-900 - 1 Second Hold-Open on PUSH-N-GO operation; Variable 2-30 second Hold-Open with remote switch	0	Zero Latch
1	77700-900 - Same Variable 2-30 second Hold-Open on PUSH-N-GO and remote switch	1	3° Latch
2	77700-900 Delayed Activation w/Setting 0	2	7° Latch
3	77700-900 Delayed Activation w/Setting 1	3	10° Latch
4	77700-900 Auto Reversing in Closing Cycle, w/Setting 0	*4	13° Latch (Standard)
5	Super-Nova Safety Slow	5	17° Latch
6	Super-Nova Safety Stop	6	20° Latch
7	77700-900 10th cycle Re-cycle w/Setting 0	7	23° Latch
8	87500-900 Door Mounted Safety Sensor	8-9	Unassigned
9	Unassigned	A-F	Unassigned
A	Unassigned	* - Boxes shipped with selector switches in these positions.	
B	Carpets / Mats		
C-D	Unassigned		
E	Alternate Action		
F	Unassigned		

For any questions: (a) Consult the complete instruction manual for the Mid-Swing Universal Control Box or (b) Call the Dor-O-Matic factory at 1-800-543-4635

4625-600 Rev.F

For any question: Call the Dor-O-Matic factory 1-800-543-4635

Figure 2: Mid-Swing 85455-900 Universal Control Box Label

FUNCTION AND LATCH LABEL DESCRIPTION

A representation of the control box function and latch label can be seen in Figure 2. This label shows how to set up the box to work in various applications. Some of the settings refer to functions while others refer to external devices. Please see complete explanations below. *Remember to disconnect the 115VAC input to the control box before changing the function or latch dials to insure proper operation.* Also note: at power-up a universal style control box will not begin its sizing mode if the main activation wires were sustained (tied together). With the activation cleared, the control will not go into sizing mode until receiving an activation signal. A manual push on the master door will also begin the sizing mode. Some older style boxes begin sizing immediately upon power-up.

77700-900, 1 Second Hold-Open on PUSH-N-GO operation; Variable 2-30 Second Hold-Open with remote switch (function 0): In this setting, the hold-open time for PUSH-N-GO is fixed at 1 second, and the hold-open time for the remote switch is variable from 2-30 seconds. The 85455-900 is shipped with the function switch in this position, if a 77700-900 sensor is used.

77700-900, Same variable 2-30 second Hold-Open on PUSH-N-GO and remote switch (function 1): This setting is similar to function 0 except that the hold-open time for PUSH-N-GO is the same as that of the remote switch.

77700-900, Delayed Activation w/Setting 0 (function 2): This setting is based on function 0. When the door is at the fully closed position, there is approximately a 1-second delay between reception of the activation signal and the actual opening of the door. This delayed activation allows most electric strikes, electric panics, or magnetic locks ample time to retract before the door opens.

77700-900, Delayed Activation w/Setting 1 (function 3): This setting is based on function 1. When the door is at the fully closed position, there is approximately a 1-second delay between reception of the activation signal and the actual opening of the door. This delayed activation allows most electric strikes, electric panics, or magnetic locks ample time to retract before the door opens.

77700-900, Automatic Reversing in Closing Cycle, w/Setting 0 (function 4): This setting is based on function 0. In this setting, the door will **re-open** if it encounters an obstacle during the **closing** cycle.

Super Nova Safety Slow (function 5): This setting is for use with the Super Nova Safety System. Once the door has begun opening, any person or object entering the swing area will cause the door to go into a safety slow speed.

Super Nova Safety Stop (function 6): This setting is similar to function 5 except that the door will stop, hold for a few seconds, then continue opening at a safety slow speed

77700-900, 10th Cycle Re-Cycle with setting 0 (function 7): This setting has a feature that opens the door automatically after the 10th manual opening of the door. This feature refreshes the microprocessor's counter and is only noticed when PUSH-N-GO is turned off and the door is opened manually.

87500-600 Door Mounted Safety Sensor (function 8): This setting is for use with the Door Mounted Safety Sensor System. Once the door has begun opening, any person or object entering the swing area will cause the door to go into a safety slow speed.

Unassigned (function 9-A):

Carpets / Mats (function B): This setting is for swing door systems that use carpets / mats.

Unassigned (function C-D):

Alternate Action (function E): When the door is fully closed (or closing), an activation signal will open (or re-open) the door. Once the door is at the fully open position, it will stay there. When the door is fully open, an activation signal will allow the door to close. Dor-O-Matic recommends using **only push buttons or key switches** in this setting. While some other devices will work, they may cause erratic and unsafe door operation.

Unassigned (function F):

Automatic Reversing

Open Cycle: Functions 0-7 have automatic reversing in the opening cycle. The door will **stop and close** if it encounters an obstacle in the **opening** cycle.

Close Cycle: Function 4 has automatic reversing in the closing cycle. The door will **re-open** if it encounters an obstacle during the **closing** cycle.

LATCH

The latch rotary selector dial allows the latch position to be set at the desired angle. The standard latch position is 13° (setting 4). This is the latch setting that all 85455-900 control boxes are factory shipped in.

DEVICES

DEVICES

Activation: Push buttons are the most basic of activating devices. Actually this can be any normally open dry contact. This can include push buttons, push plates, card readers, keypads, relays, etc. as long as it is a normally open dry contact. ***No external voltage can be applied to the activating wires of the control box!*** These devices are usually momentary contacts although sustained contacts may be used if necessary. The Mid-Swing unit is designed to hold the door open under a sustained activation without damaging itself, note: at power-up the main activation should be cleared until control completes the sizing mode.

77700-900: Function settings 0-4 & 7 are intended for use with the sensor. These sensors should only be used with the rocker switch (84220-900), or keyswitch (84219-900).

Super Nova: Function settings 5 & 6 are intended for use with the Super Nova Safety System. These sensors should only be used with the rocker switch (84220-900), or keyswitch (84219-900).

87500-900: Function setting 8 is intended for use with the 87500-900 Door Mounted Safety Sensor. These sensors should only be used with the rocker switch (84220-900), or keyswitch (84219-900).

Carpets/Mats: Carpets/Mats can be used on the activating and/or safety side. When someone stands on the activating carpet/mat and the safety carpet/mat is unoccupied, the door will open and stay open as long as someone is standing on the activating carpet/mat. When the activating carpet/mat is clear and the safety carpet/mat is unoccupied, the door will time out and close. Standing on a safety carpet /mat will, (1) keep a fully closed door from opening, or (2) keep a fully opened door from closing. There are no safety stop or safety slow features on carpets/mats. The safety carpet/mat always takes precedence over the activating carpet/mat. Carpets/Mats should only be used with the rocker switch (84220-900), or key switch (84219-900), and adapter harness (95168-600).

DOR-O-MATIC

ATTENTION: DYNAMIC BRAKE HARNESS NOW REQUIRED FOR MID-SWING™

This past September, Dor-O-Matic updated its Astro, Senior, and Mid-Swing packages to make them fully compliant with new U.L. requirements. The Mid-Swing control box included with this notice is a U.L. style control box and can be easily identified by the fuse holder in the motor voltage harness.

IF YOU INTEND TO USE THIS CONTROL BOX IN AN EXISTING INSTALLATION WITH MID-SWING MOTOR GEARBOX (83800-901/-902/-401/-402), IT IS IMPORTANT TO ADD A DYNAMIC BRAKE HARNESS (95970-600) TO EACH MOTOR.

If you intend to use this control box with Mid-Swing Motor Gearbox 83830-901/-902/-401/-402, it is not necessary to add a dynamic brake harness.

The dynamic brake harness has two plugs that connect to the motor and the control box. The housing attaches easily to the operator. It is simple to install, and your customers will appreciate having the very latest product upgrade to ensure complete safety on their Mid-Swing installation.

Note: When servicing doors in applications that currently use the 83800-901/-902/-401/-402 motor gear box assembly without a dynamic brake, use extreme caution as the door will slam when the control box is disconnected from the motor.



ASTRO®, SENIOR™ and MIDDLE SWING™ TROUBLE-SHOOTING CHART

**Make sure the "FUNCTION" and "LATCH SELECTOR DIAL" is set properly
before starting to trouble-shoot equipment.**

PROBLEM	TEST	CAUSE	SOLUTION
Door will not open when activated	1) Check on-off-hold open switch and on-off switch.	Switch is in off position.	Place switch in "on" position.
	2) Check circuit breaker and fuse.	Circuit breaker tripped. Fuse blown.	Push circuit breaker into on position and replace fuse.
	3) Set VOM to 120 volts AC scale. Place meter probes on transformer panel. If meter does not read 117 volts....	Power supply has been interrupted. Circuit breaker at main panel tripped.	Reset main panel breaker.
	4) Place VOM meter leads on normally open contact leads from activation device. If closer is not indicated on meter when device is activated.....	Activation device is inoperative or voltage not supplied to device.	Restore voltage or replace device.
	5) Shut power off. Remove fuses from control box and motor leads. If fuse reads infinite OHMS....	Fuses open.	Replace fuse.
	6) Place jumper across blue and gray wires of control box. If door opens...	Activation device is inoperative.	Replace activation device.
	7) If after performing the above tests and the control box does not open when sensor is activated...	Control box is faulty.	Replace control box.
Door will not fully open	1) Manually push door open and close. If not working freely....	Door binding.	Adjust door to eliminate binding.
	2) Check for loose or bad connections of wires.	Doors has loose or bad connections.	Rework wiring and make sure all connections are good.
Door will not size	1) Manually push door open and close. If door is hard to open and close...	Door binding.	Adjust door to eliminate binding.
	2) Check for loose or bad connections on wires.	Doors with loose or bad connections.	Rework wiring and make sure all connections are good.
	3) Test motor. Disconnect power. Place VOM meter lead to motor wire and test to ground. If meter reads other than infinite OHMS....	Faulty motor.	Replace motor.
Door will not close.	1) Turn off power. Push door to 90 degrees. If door does not close.	Operator spring broken.	Replace motorgear box.
	2) Disconnect all activation and safety devices from control box. If door holds open under power.	Faulty control box.	Replace control box.



TROUBLE-SHOOTING GUIDE ASTRO®, SENIOR™, MIDDLE SWING™ INSTALLATION

Cause	Dead	Will not open	Will not open fully	Erratic open or closing	Will not size	Will not close	Recycle	Blows fuse or circuit breaker
115 V Off	X	X						
Improper Wiring	X	X						
Not Connected	X	X						
Open Circuit Breaker	X	X						
Blown Fuse	X	X						
Door Locked	X	X						
Low Voltage	X	X						
Open Switch Off Position	X	X						
Inoperative Activating Device		X						
Door Binding		X	X	X	X	X	X	
Orange Jumper Not Installed		X						
Loose Wires	X	X		X	X		X	
Hall Unit Inoperative				X	X			X
Activation Device Activated						X		
Phantoming Motion Detector					X		X	
Shortened Wires	X	X		X	X	X	X	X
Shortened Motor		X					X	X
Voltage Spike				X	X	X	X	X
Improper Arm Installation		X	X		X		X	
Broken Operator Spring						X		