

DON-JO

Templates

Master Index

| REVISIONS | | | |
|-----------|-----|---------------------|----------|
| ZONE | REV | FINISHES : | DATE |
| | | 605,613,619,620,626 | APPROVED |

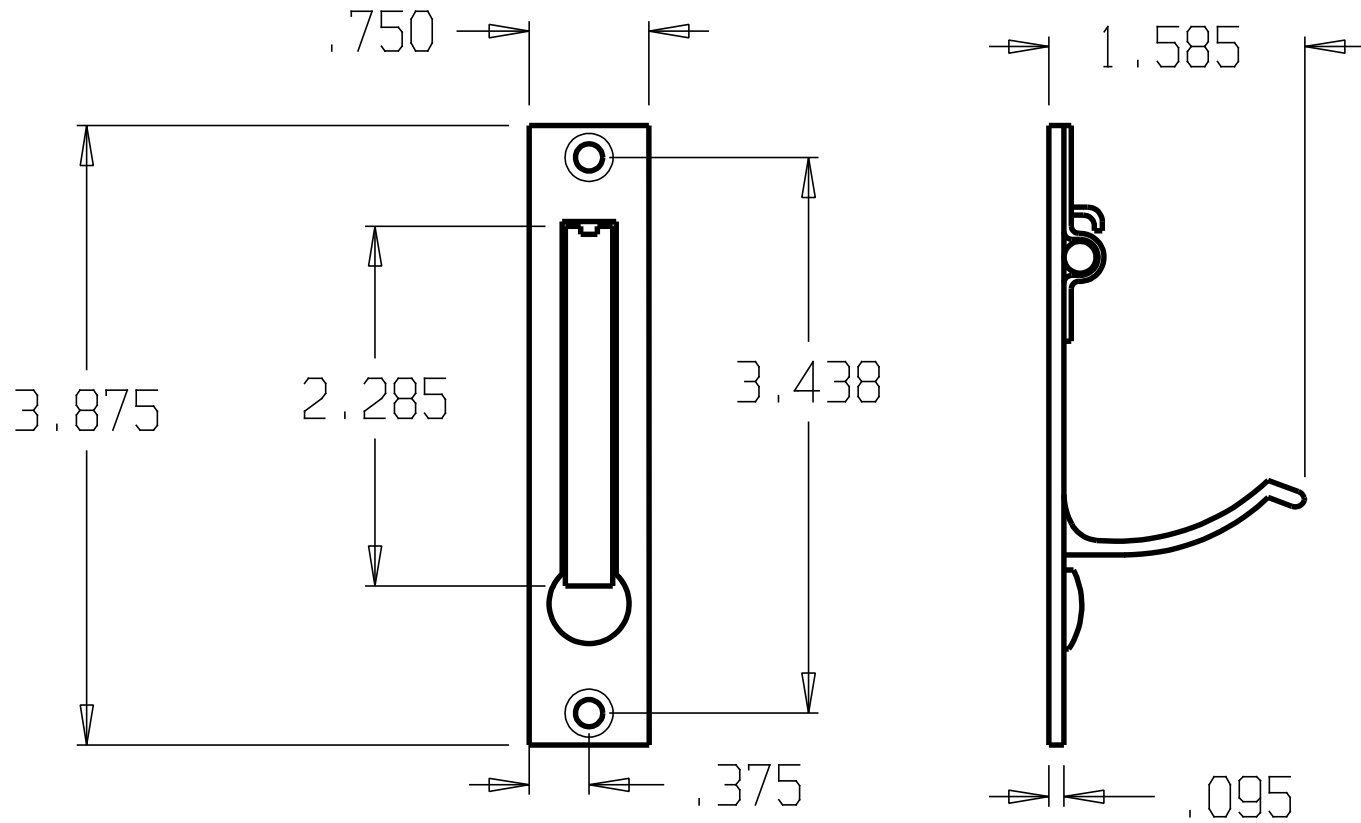

DON-JO MFG. INC.

DESIGNER
APPROVED

| | | | |
|-----------|------------------|------------------|-------|
| SIZE A | DATE: 2/10/04 | PART NO. #104 | REV |
| SCALE | RELEASE DATE | WEIGHT | SHEET |

| REVISIONS | | | | |
|-----------|-----|-------------------------|------|----------|
| ZONE | REV | FINISHES: | DATE | APPROVED |
| | | 605, 613, 619, 620, 626 | | |

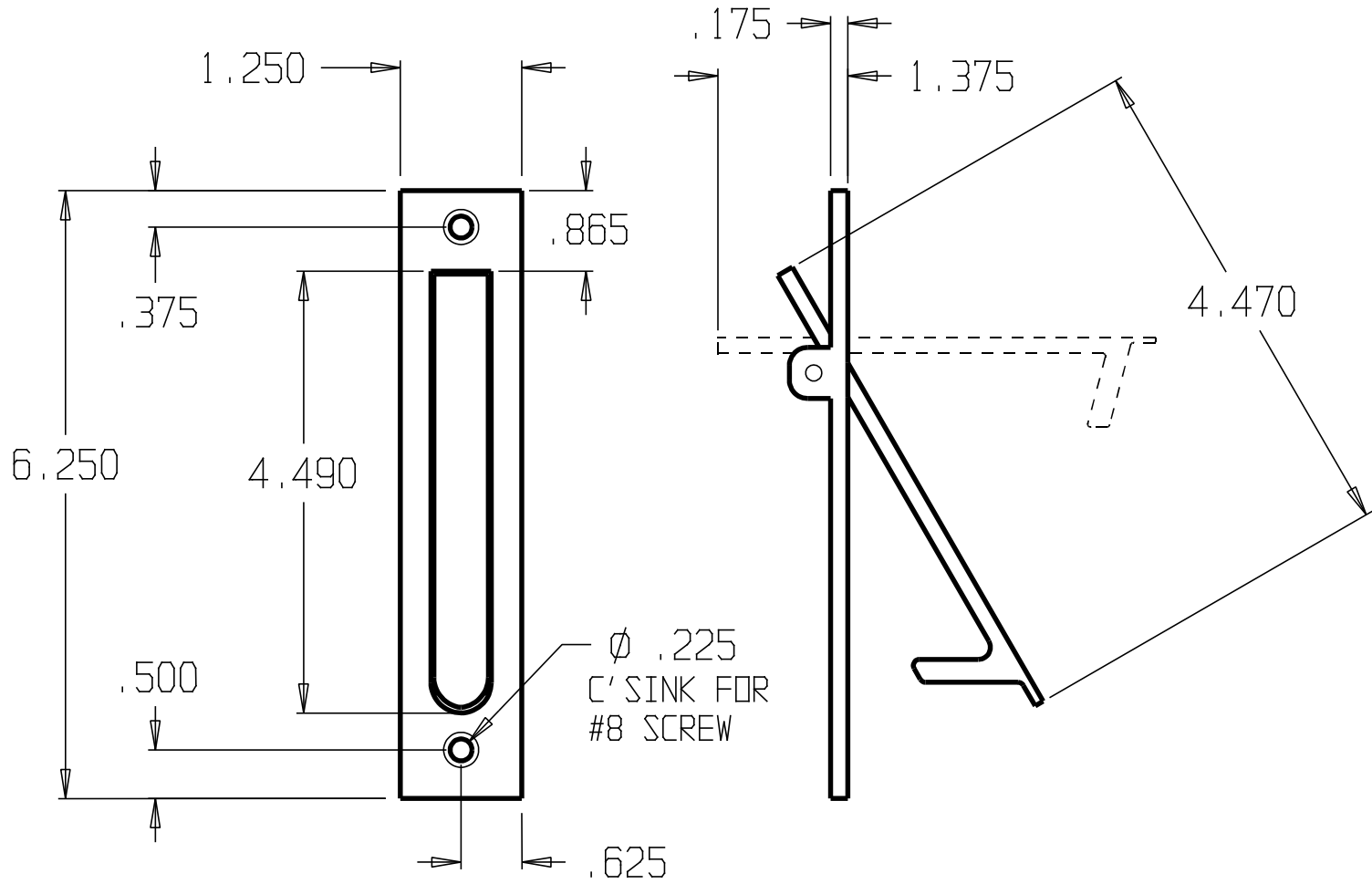

DON-JO MFG. INC.

| | | | | |
|----------|-----------|------------------|------------------|-------|
| DESIGNER | SIZE A | DATE: 2/10/04 | PART NO. #106 | REV |
| APPROVED | SCALE | RELEASE DATE | WEIGHT | SHEET |

| REVISIONS | | | | |
|-----------|-----|------------------------------|------|----------|
| ZONE | REV | FINISHES : | DATE | APPROVED |
| | | 605, 609, 613, 619, 620, 625 | | |

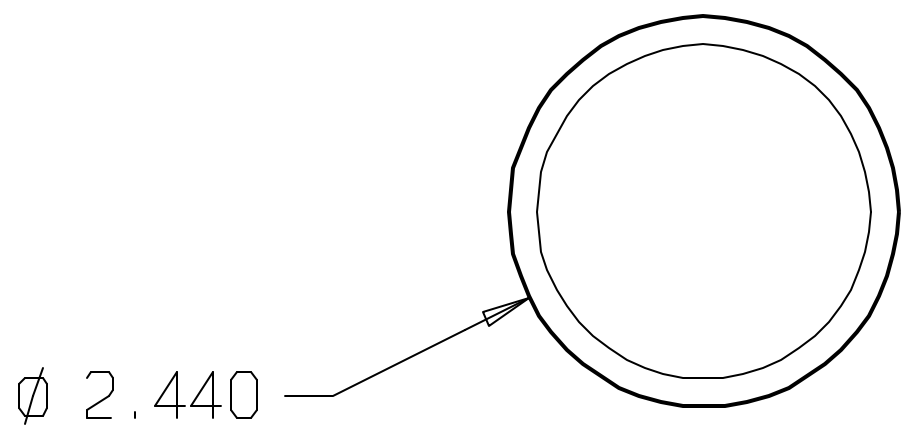
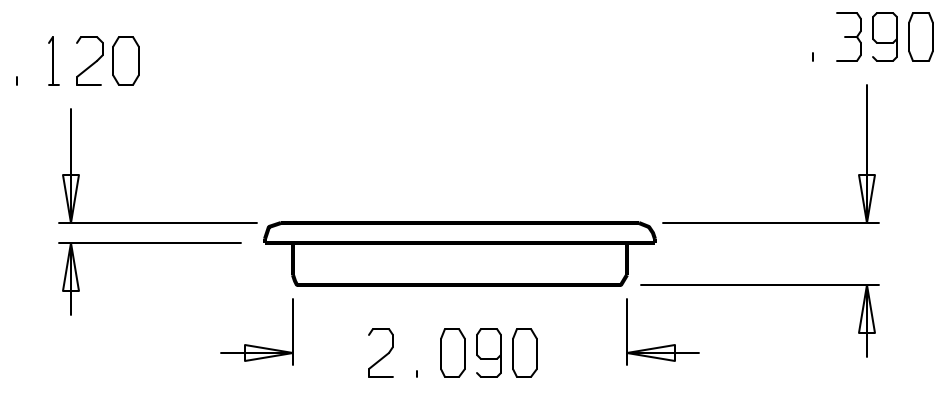

DON-JO MFG. INC.

DESIGNER
APPROVED

SIZE: **A**
DATE: **2/10/04**

PART NO.: **#125**
REV

SCALE RELEASE DATE WEIGHT SHEET

| REVISIONS | | | | |
|-----------|-----|-----------------------------|------|----------|
| ZONE | REV | FINISHES: | DATE | APPROVED |
| | | 605,609,613,619,620,625,626 | | |

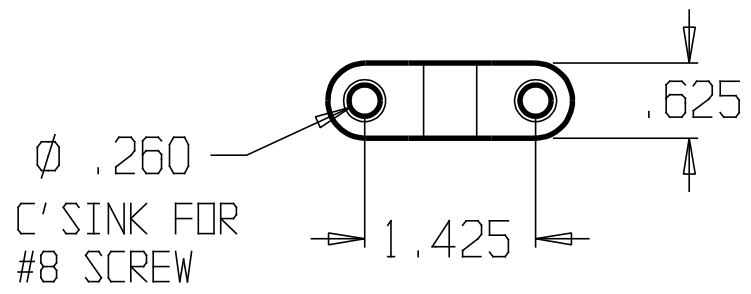
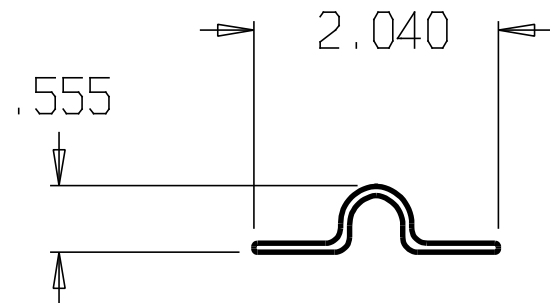
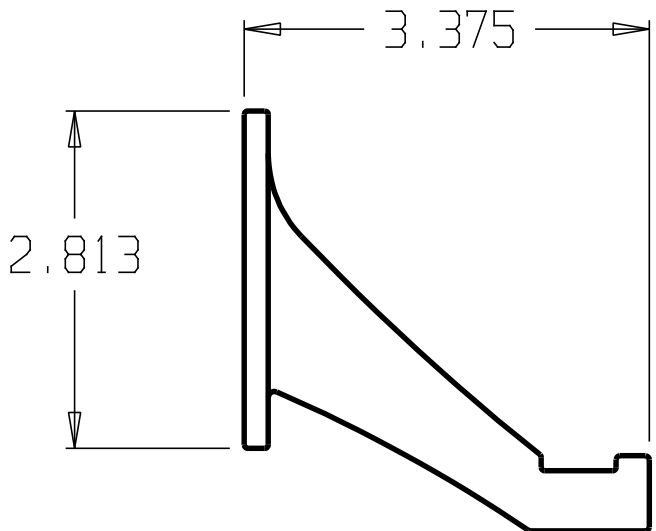

DON-JO MFG. INC.

| | | | | |
|----------|-----------|------------------|------------------|-------|
| DESIGNER | SIZE A | DATE: 2/10/04 | PART NO. #130 | REV |
| APPROVED | SCALE | RELEASE DATE | WEIGHT | SHEET |

| REVISIONS | | | |
|-----------|-----|-------------------------|----------|
| ZONE | REV | FINISHES : | DATE |
| | | 605, 613, 619, 620, 626 | |
| | | | APPROVED |

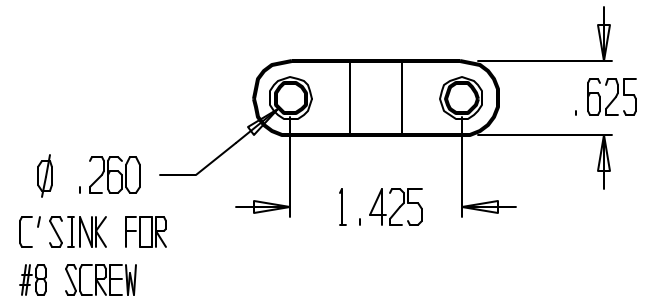
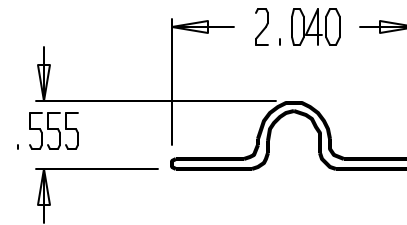
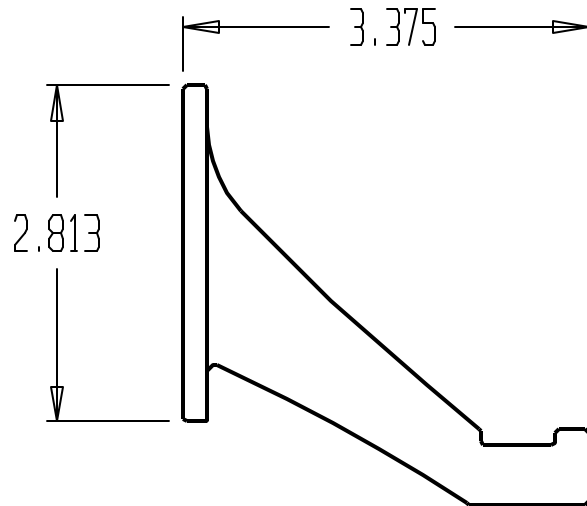

DON-JO MFG. INC.

| | | | | |
|----------|-------|--------------|----------|-------|
| DESIGNER | SIZE | DATE: | PART NO. | REV |
| | A | 2/10/04 | #135 | |
| APPROVED | SCALE | RELEASE DATE | WEIGHT | SHEET |

| REVISIONS | | | | |
|-----------|-----|---------------|------|----------|
| ZONE | REV | FINISHES: | DATE | APPROVED |
| | | 605, 625, 626 | | |

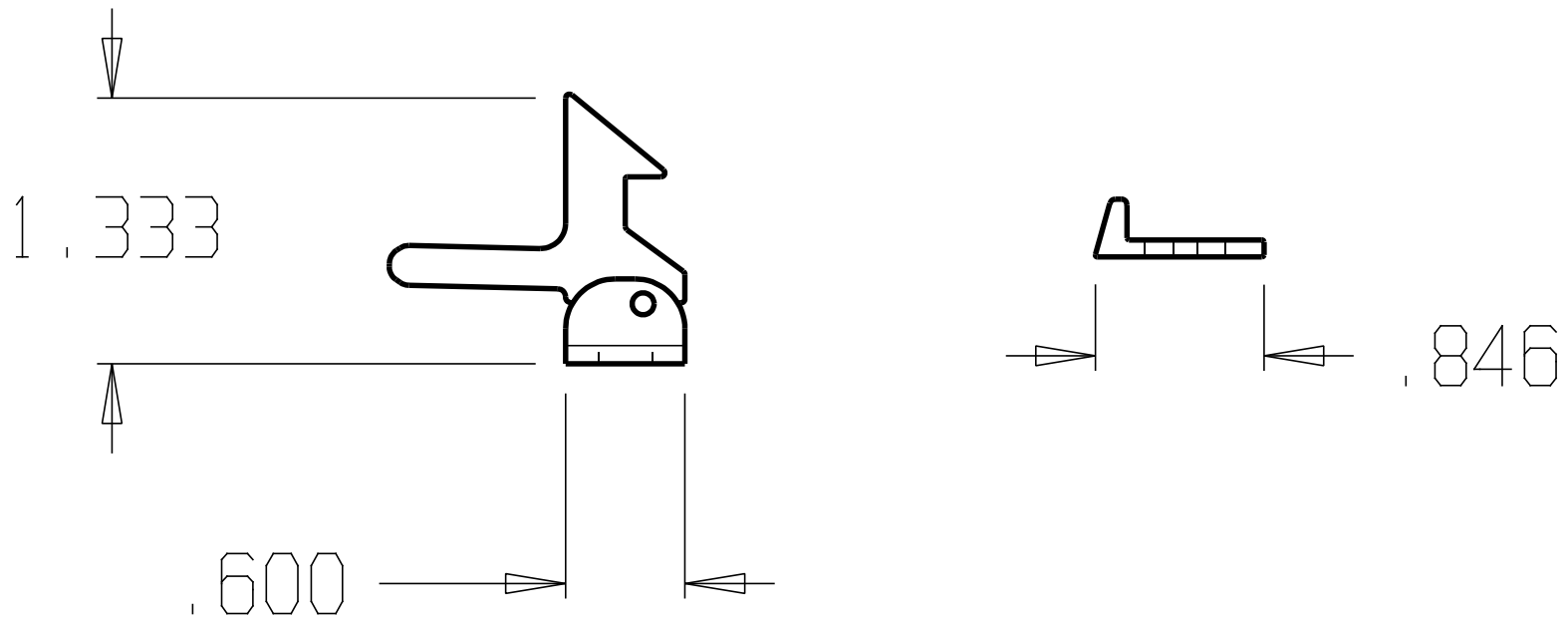

DON-JO MFG. INC.

| | | | | |
|----------|--------|---------------|----------------|-------|
| DESIGNER | SIZE A | DATE: 3/25/04 | PART NO. #1590 | REV |
| APPROVED | SCALE | RELEASE DATE | WEIGHT | SHEET |

| REVISIONS | | | | |
|-----------|-----|--------------------|------|----------|
| ZONE | REV | FINISHES: | DATE | APPROVED |
| | | 605, 606, 625, 626 | | |

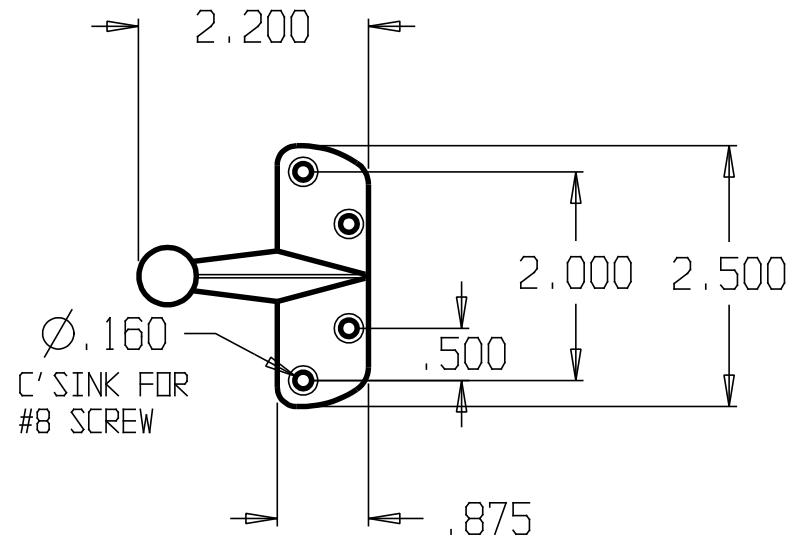
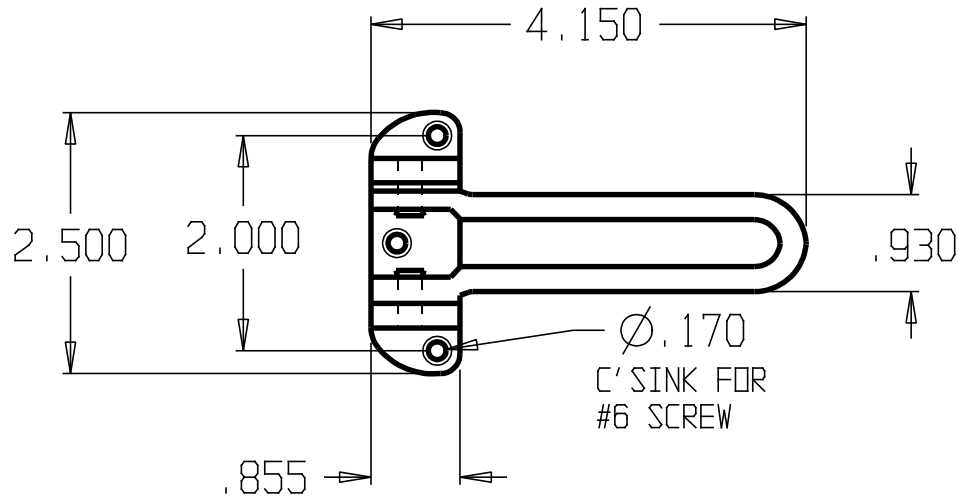

DON-JO MFG. INC.

| | | | | |
|----------|-----------|------------------|-------------------|-------|
| DESIGNER | SIZE A | DATE: 3/25/04 | PART NO. #1603 | REV |
| APPROVED | SCALE | RELEASE DATE | WEIGHT | SHEET |

| REVISIONS | | | | |
|-----------|-----|--------------------|------|----------|
| ZONE | REV | FINISHES: | DATE | APPROVED |
| | | 605, 606, 625, 626 | | |

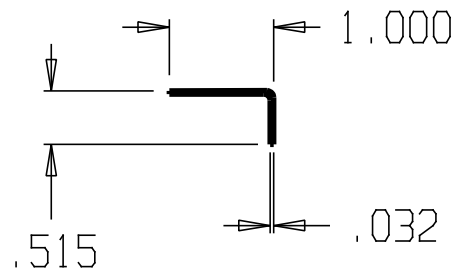
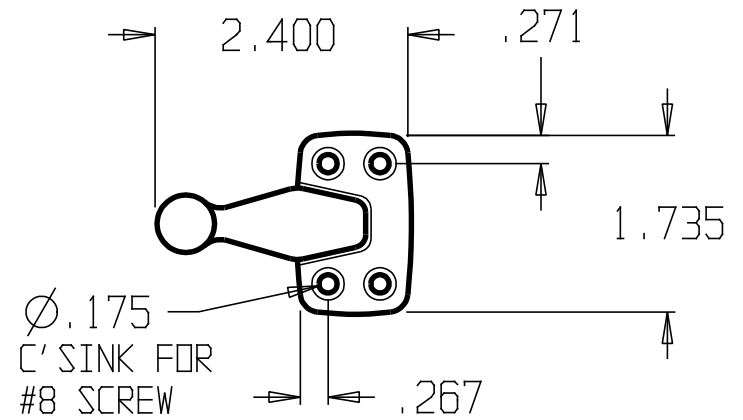
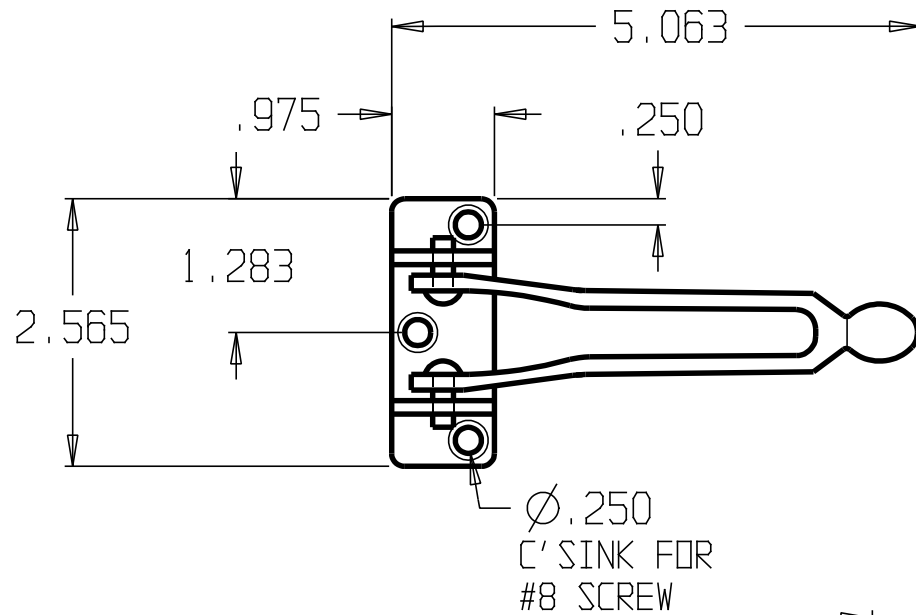

DON-JO MFG. INC.

| | | | | |
|----------|--------|---------------|----------------|-------|
| DESIGNER | SIZE A | DATE: 3/25/04 | PART NO. #1604 | REV |
| APPROVED | SCALE | RELEASE DATE | WEIGHT | SHEET |

| REVISIONS | | | | |
|-----------|-----|------------|------|----------|
| ZONE | REV | FINISHES : | DATE | APPROVED |
| | | 605, 626 | | |

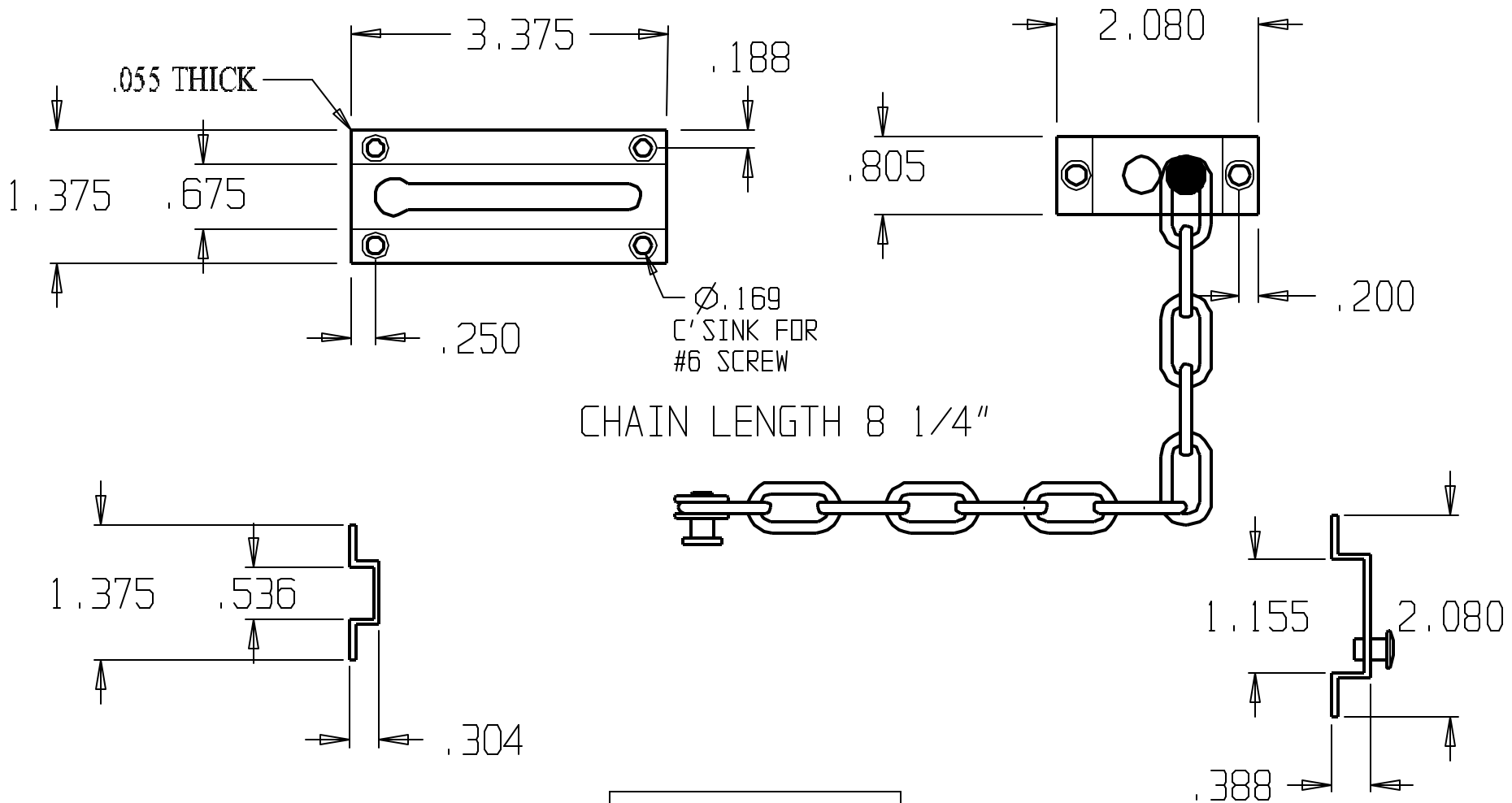

DON-JO MFG. INC.

| | | | | |
|----------|-----------|------------------|-------------------|-------|
| DESIGNER | SIZE A | DATE: 3/25/04 | PART NO. #1607 | REV |
| APPROVED | SCALE | RELEASE DATE | WEIGHT | SHEET |

| REVISIONS | | | | |
|-----------|-----|-----------|------|----------|
| ZONE | REV | FINISHES: | DATE | APPROVED |
| | | 605 | | |

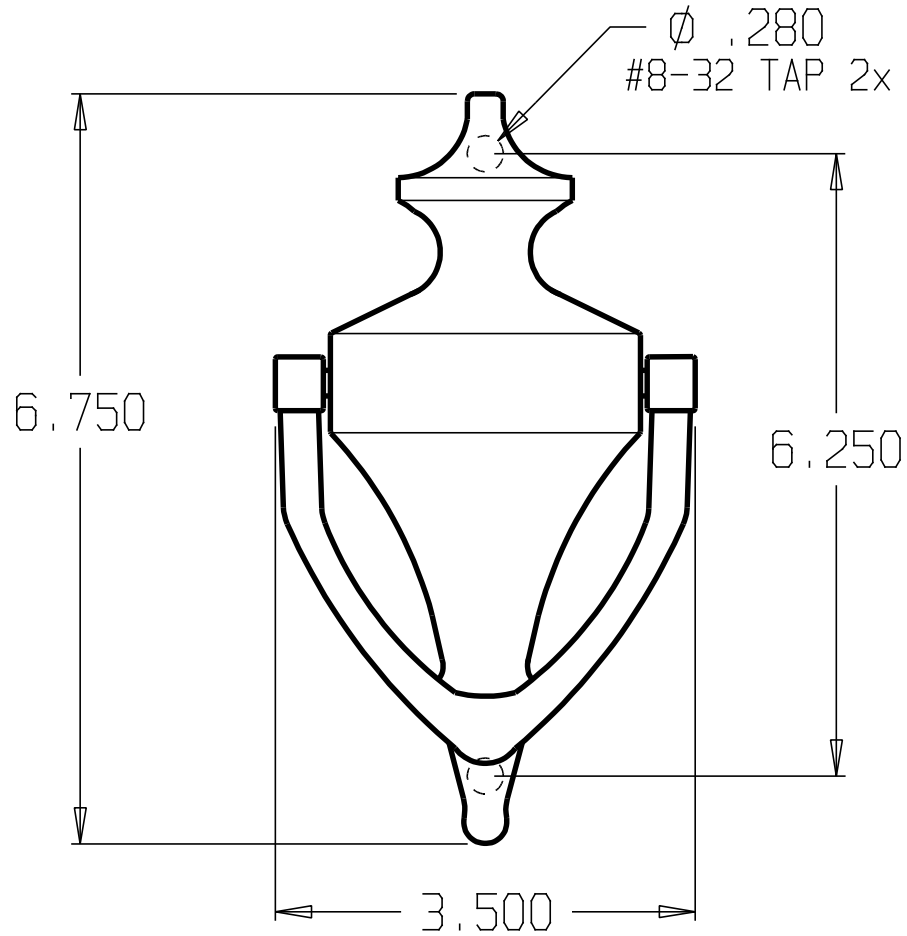

DON-JO MFG. INC.

| | | | | |
|----------|-----------|------------------|-------------------|-------|
| DESIGNER | SIZE A | DATE: 3/29/04 | PART NO. #1611 | REV |
| APPROVED | SCALE | RELEASE DATE | WEIGHT | SHEET |

DWG NO. SH REV

REVISIONS

| ZONE | REV | FINISHES: | DATE | APPROVED |
|------|-----|-------------------------|------|----------|
| | | 605, 613, 619, 620, 625 | | |

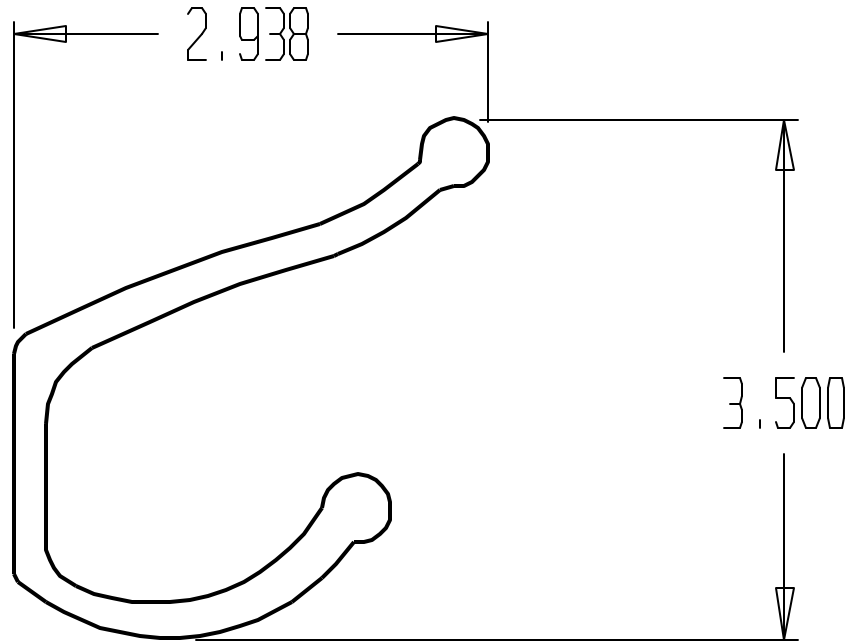

DON-JO MFG. INC.

| | | | | |
|----------|-----------|------------------|------------------|-------|
| DESIGNER | SIZE A | DATE: 4/20/04 | PART NO. #300 | REV |
| APPROVED | SCALE | RELEASE DATE | WEIGHT | SHEET |

| REVISIONS | | | | |
|-----------|-----|-------------------------|------|----------|
| ZONE | REV | FINISHES: | DATE | APPROVED |
| | | 605, 613, 619, 620, 625 | | |

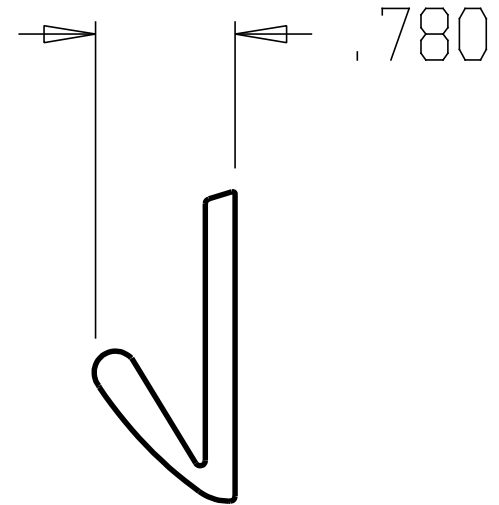
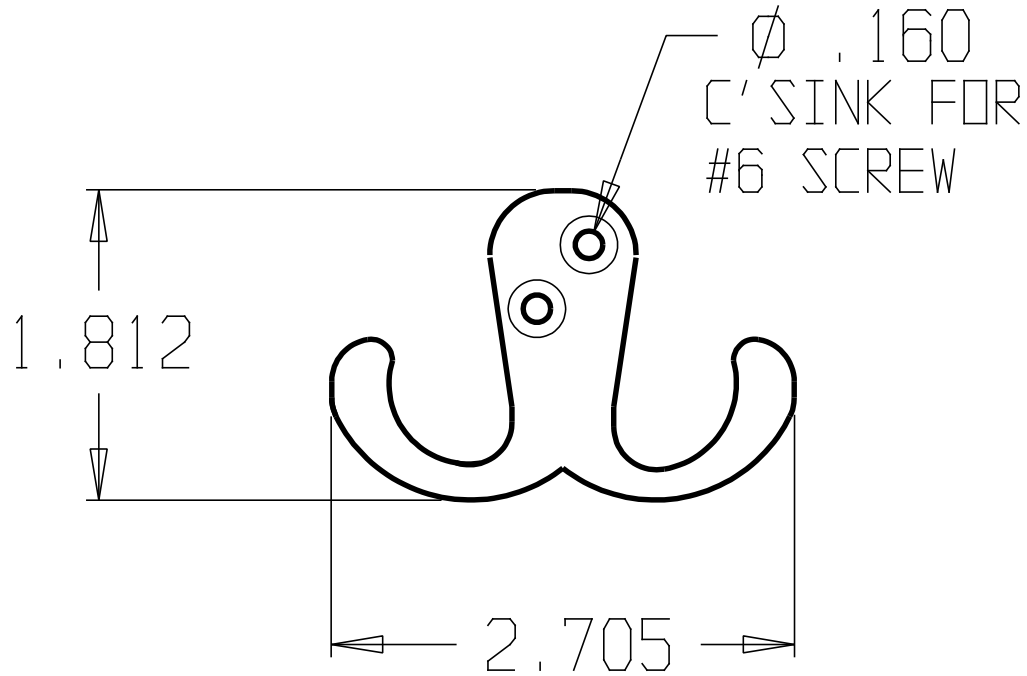

DON-JO MFG. INC.

| | | | | |
|----------|-----------|------------------|------------------|-------|
| DESIGNER | SIZE A | DATE: 4/21/04 | PART NO. #302 | REV |
| APPROVED | SCALE | RELEASE DATE | WEIGHT | SHEET |

| | | |
|--------|----|-----|
| DWG NO | SH | REV |
|--------|----|-----|

REVISIONS

| | | | | |
|------|-----|------------|-----|----------|
| ZONE | REV | FINISHES : | 630 | GALUGE : |
|------|-----|------------|-----|----------|

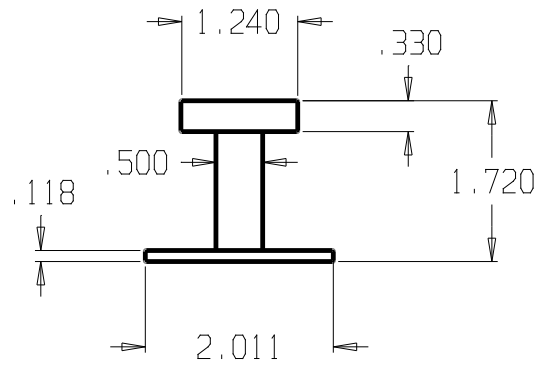

DON-JO MFG. INC.

| | |
|----------|------|
| DESIGNER | D.R. |
|----------|------|

| | | | | | | |
|-------|---|--------------|---------|----------|------|-------|
| SIZE | A | DATE: | 5/17/13 | PART NO. | #304 | REV |
| SCALE | | RELEASE DATE | | WEIGHT | | SHEET |

| | | |
|---------|----|-----|
| DWG NO. | SH | REV |
|---------|----|-----|

| REVISIONS | | |
|-----------|-----|-------------------|
| ZONE | REV | FINISHES: |
| | | 605,613,619 & 626 |
| | | GALUGE: |

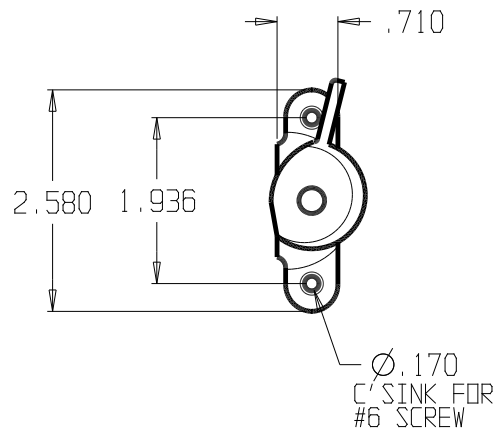
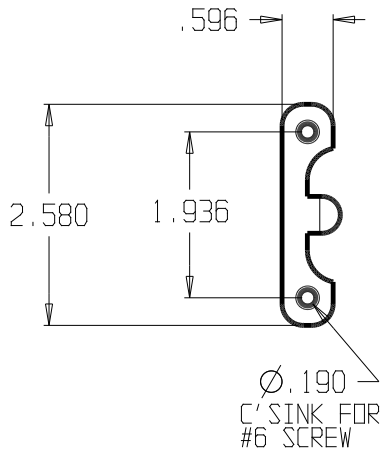

| | | | | | | | |
|-------------------------|------|--------------|--------|--------|-------|----------|-----|
| DON-JO MFG. INC. | | | | SIZE | DATE: | PART NO. | REV |
| DESIGNER | D.R. | A | 6/3/10 | #350 | | | |
| SCALE | | RELEASE DATE | | WEIGHT | SHEET | | |

| REVISIONS | | |
|-----------|-----|---------------|
| ZONE | REV | FINISHES: |
| | | 605, 606, 626 |
| | | GALUGE: |
| | | 18ga. .050 |

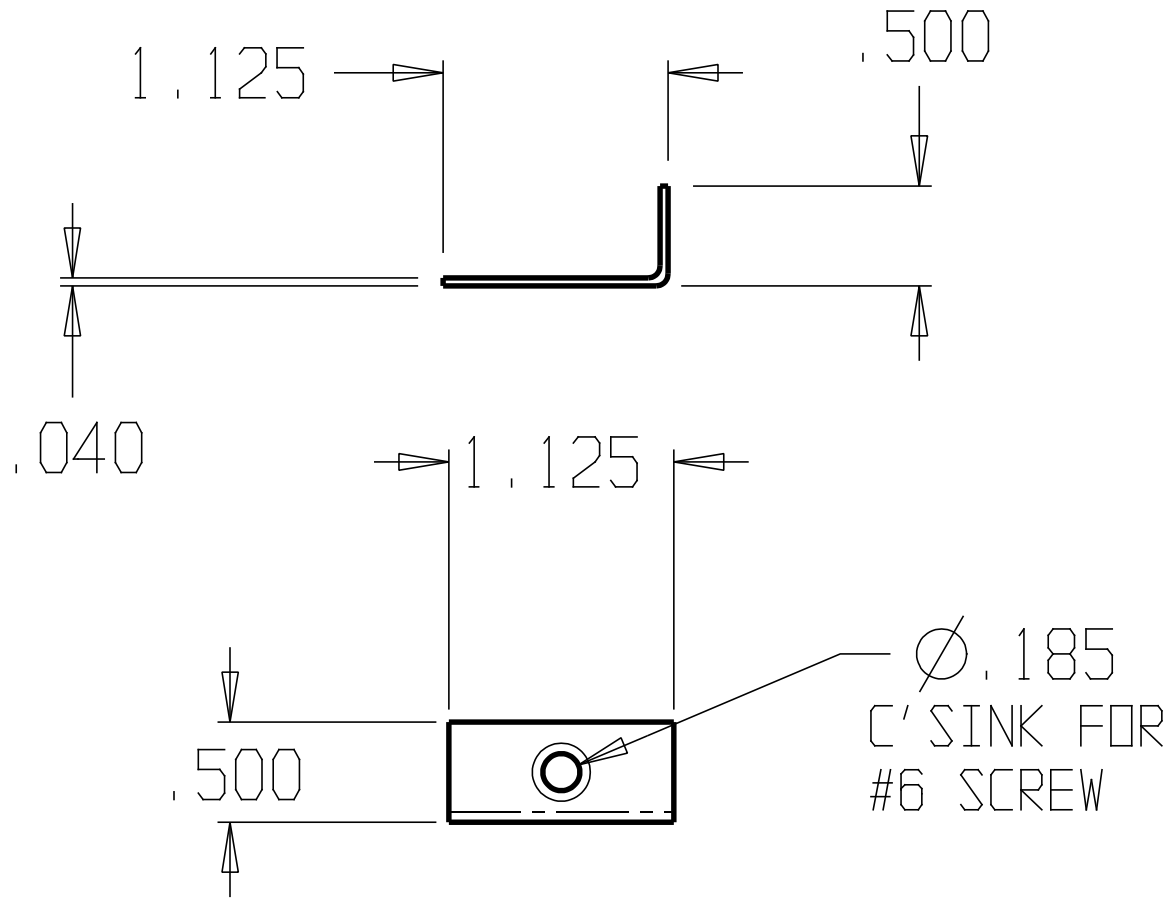

DON-JO MFG. INC.

| | | | | |
|----------|-------|--------------|----------|-------|
| DESIGNER | SIZE | DATE: | PART NO. | REV |
| | A | 5/3/04 | AP-34 | |
| APPROVED | SCALE | RELEASE DATE | WEIGHT | SHEET |
| | | | | |

| REVISIONS | | | |
|-----------|-----|-----------|-------------|
| ZONE | REV | FINISHES: | GAUGE: |
| | | 605 | 3/16" THICK |

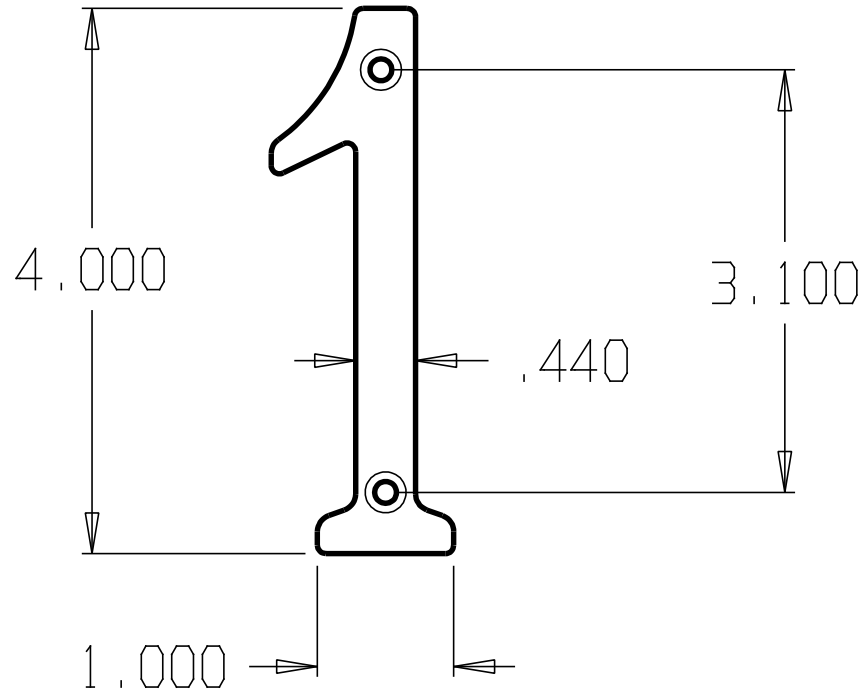

DON-JO MFG. INC.

DESIGNER
APPROVED

SIZE: A
DATE: 5/4/04
SCALE

PART NO. BN4-1
RELEASE DATE
WEIGHT
SHEET

| REVISIONS | | | |
|-----------|-----|-----------|--------|
| ZONE | REV | FINISHES: | GAUGE: |
| | | ZINC | |

WITH VINYL CHAIN COVER
CHAIN LENGTH: 21.75"

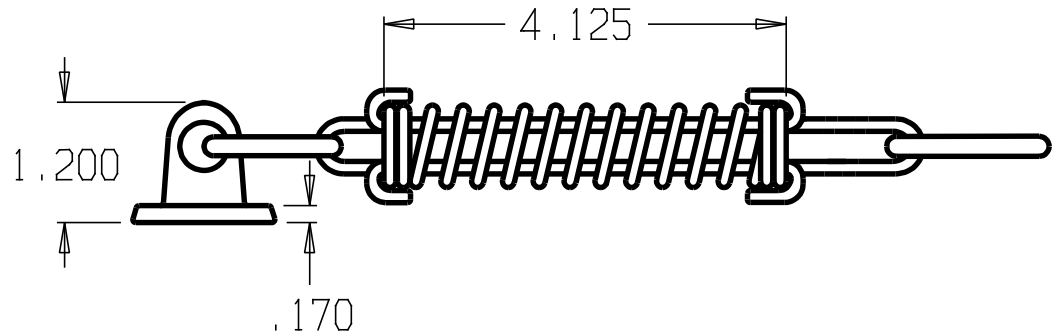
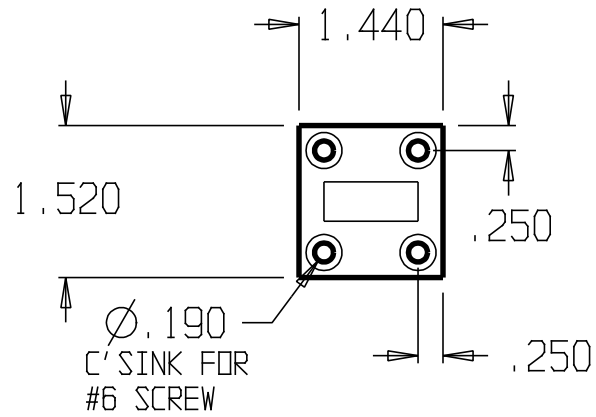

DON-JO MFG. INC.

| | | | | |
|----------|-------|--------------|----------|-------|
| DESIGNER | SIZE | DATE: | PART NO. | REV |
| | A | 5/4/04 | CC-100 | |
| APPROVED | SCALE | RELEASE DATE | WEIGHT | SHEET |
| | | | | |

| REVISIONS | | | |
|-----------|-----|-----------|--------|
| ZONE | REV | FINISHES: | GUAGE: |
| | | BP & CP | |

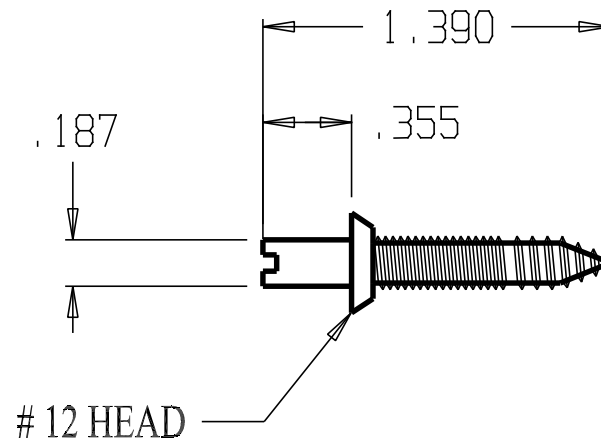

PACKED 2 PER BAG

DON-JO MFG. INC.

| | | | | |
|----------|-------|--------------|----------|-------|
| DESIGNER | SIZE | DATE: | PART NO. | REV |
| | A | 5/4/04 | CHP-100 | |
| APPROVED | SCALE | RELEASE DATE | WEIGHT | SHEET |

| | | |
|---------|----|-----|
| DWG NO. | SH | REV |
|---------|----|-----|

REVISIONS

| ZONE | REV | FINISHES: | GALUGE: |
|------|-----|---------------------|------------|
| | | 605, 609, 612 & 630 | 22ga. .032 |

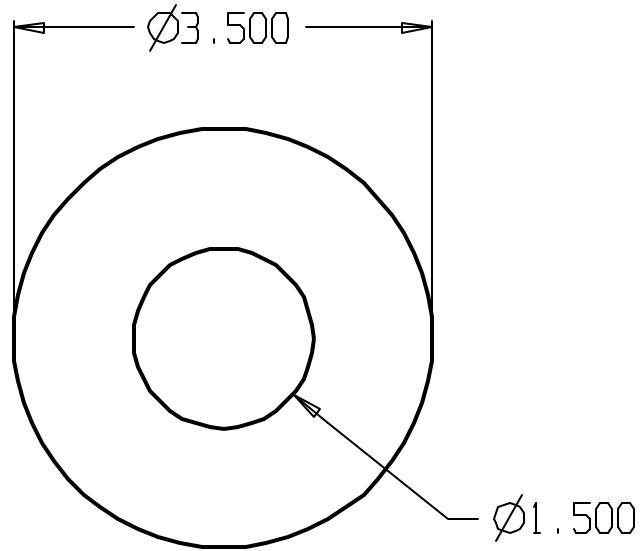

DON-JO MFG. INC.

| | | | | |
|----------|-------|--------------|----------|-------|
| DESIGNER | SIZE | DATE: | PART NO. | REV |
| | A | 5/12/04 | DSP-135 | |
| APPROVED | SCALE | RELEASE DATE | WEIGHT | SHEET |
| | | | | |

| REVISIONS | | | |
|-----------|-----|-----------|--------|
| ZONE | REV | FINISHES: | GAUGE: |
| | | 605 & 626 | |

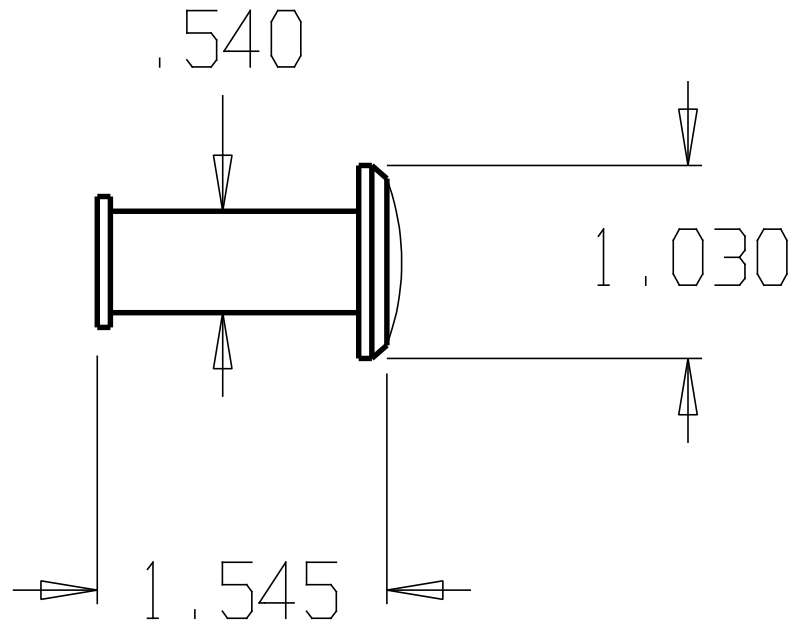

DON-JO MFG. INC.

| | | | | |
|----------|-------|--------------|----------|-------|
| DESIGNER | SIZE | DATE: | PART NO. | REV |
| | A | 5/12/04 | DV-180 | |
| APPROVED | SCALE | RELEASE DATE | WEIGHT | SHEET |
| | | | | |

| REVISIONS | | | |
|-----------|-----|-----------|--------|
| ZONE | REV | FINISHES: | GUAGE: |
| | | 605 & 626 | |

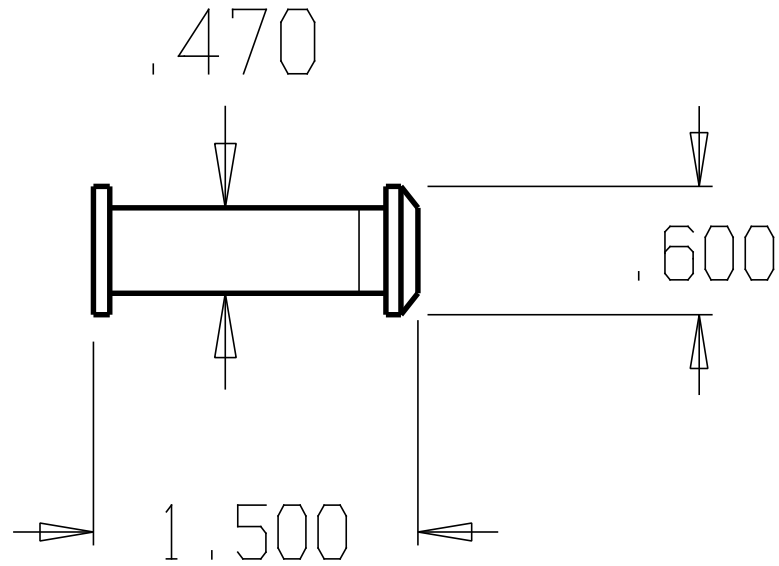

DON-JO MFG. INC.

| | | | | |
|----------|-------|--------------|----------|-------|
| DESIGNER | SIZE | DATE: | PART NO. | REV |
| | A | 5/12/04 | DV-90 | |
| APPROVED | SCALE | RELEASE DATE | WEIGHT | SHEET |
| | | | | |

| REVISIONS | | | |
|-----------|-----|---------------|--------|
| ZONE | REV | FINISHES: | GAUGE: |
| | | 605, 613, 626 | .020 |

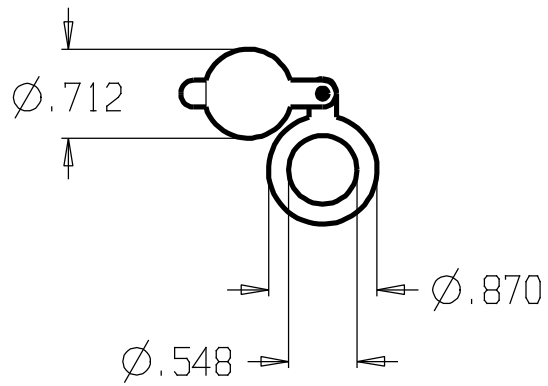

DON-JO MFG. INC.

DESIGNER
D.R.

| | | | |
|-----------|------------------|-----------------|-------|
| SIZE A | DATE: 12/9/11 | PART NO. DVC | REV |
| SCALE | RELEASE DATE | WEIGHT | SHEET |

| REVISIONS | | | |
|-----------|-----|-----------|------------|
| ZONE | REV | FINISHES: | GAUGE: |
| | | 605 & 630 | 22ga. .032 |

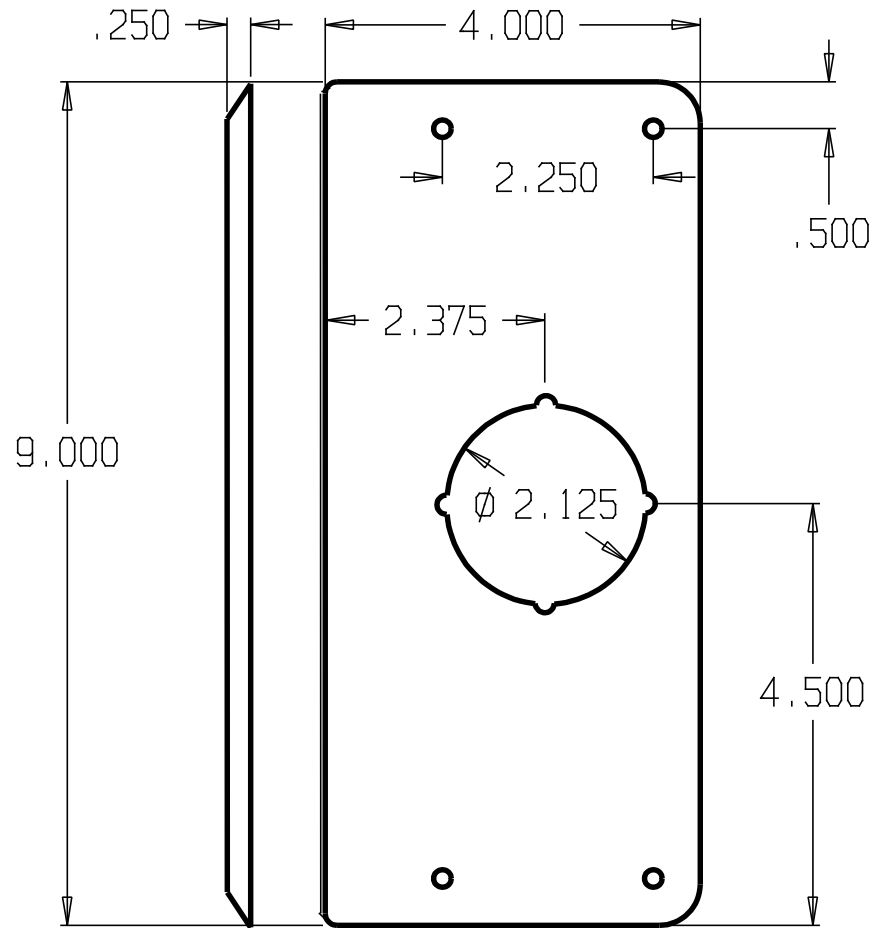

DON-JO MFG. INC.

| | | | | |
|----------|-----------|------------------|------------------|-------|
| DESIGNER | SIZE A | DATE: 5/17/04 | PART NO. EM-2 | REV |
| APPROVED | SCALE | RELEASE DATE | WEIGHT | SHEET |

| REVISIONS | | | |
|-----------|-----|-----------|------------|
| ZONE | REV | FINISHES: | GAUGE: |
| | | 605 & 630 | 22ga. .032 |

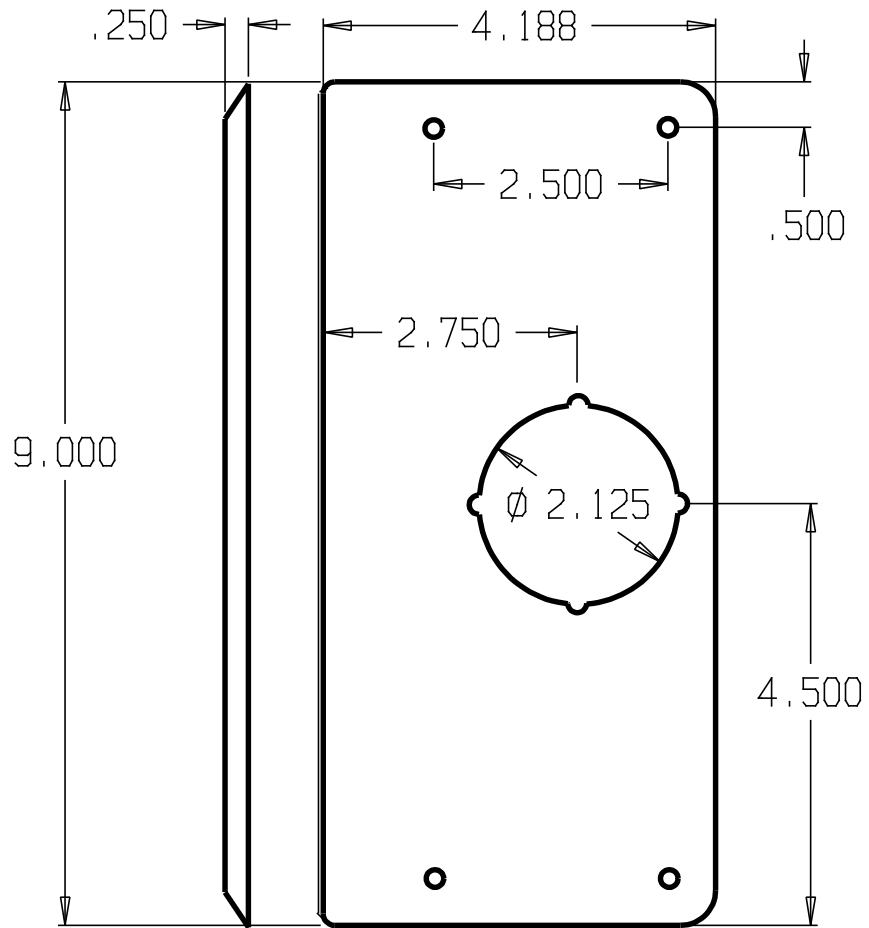

DON-JO MFG. INC.

| | | | | |
|----------|-------|--------------|----------|-------|
| DESIGNER | SIZE | DATE: | PART NO. | REV |
| | A | 5/17/04 | EM-4 | |
| APPROVED | SCALE | RELEASE DATE | WEIGHT | SHEET |
| | | | | |

| REVISIONS | | |
|-----------|-----|---|
| ZONE | REV | FINISHES: |
| | | 605, 609, 613, 619, 620, 622, 625, 626, 605X625 |

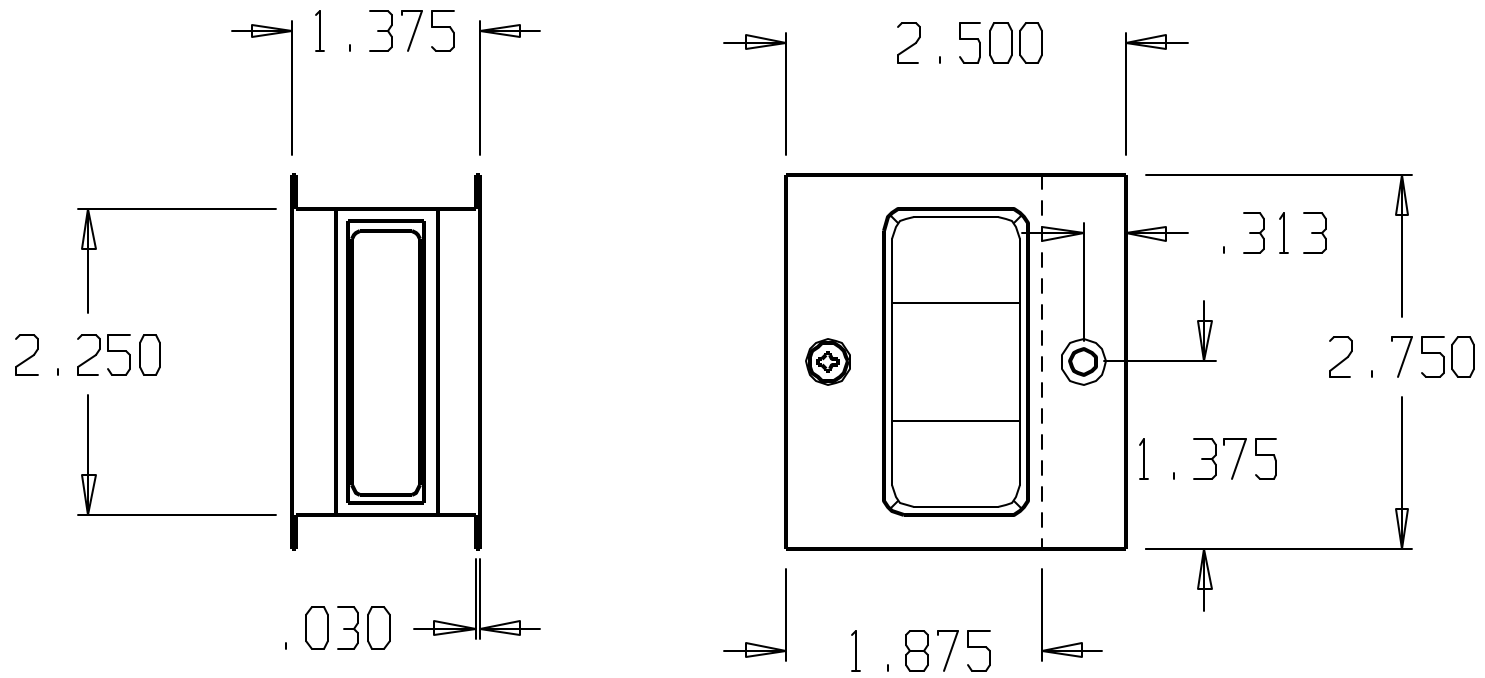

Passage

| | | | | | |
|------------------|--|-------|--------------|----------|-------|
| DON-JO MFG. INC. | | SIZE | DATE: | PART NO. | REV |
| DESIGNER | | A | 6/3/04 | PDL-100 | |
| APPROVED | | SCALE | RELEASE DATE | WEIGHT | SHEET |

| REVISIONS | | |
|-----------|-----|---|
| ZONE | REV | FINISHES: |
| | | 605, 609, 613, 619, 620, 622, 625, 626, 605x625 |

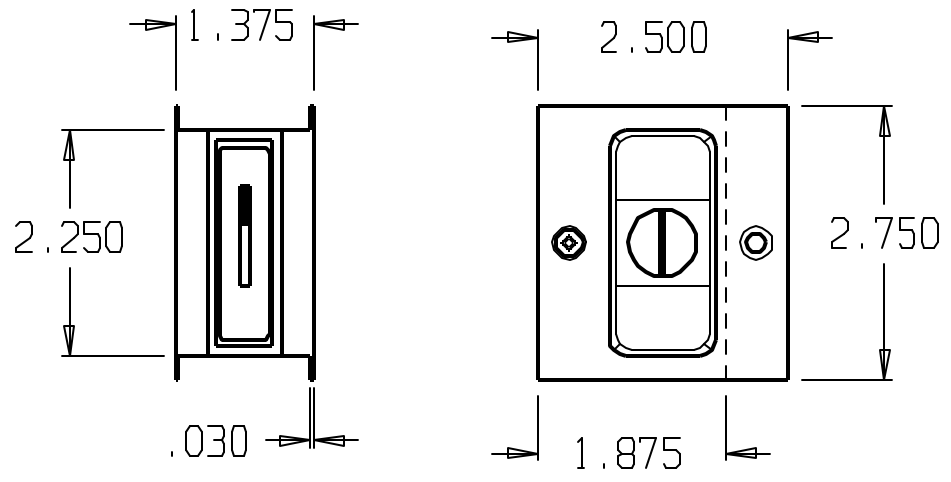

.050 THICK

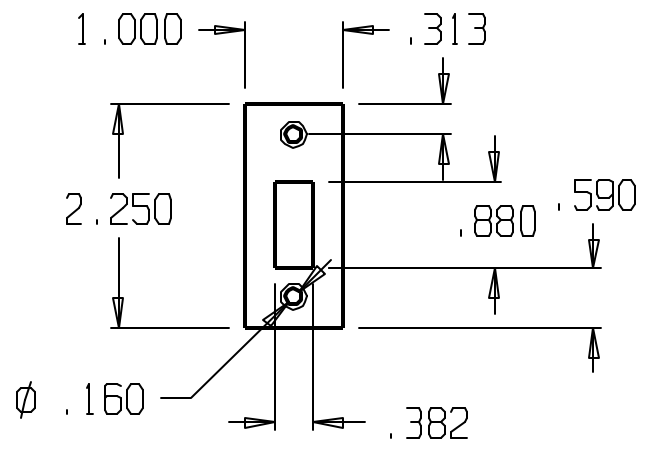

Privacy

DON-JO MFG. INC.

| | | | | |
|----------|-----------|----------------|---------------------|-------|
| DESIGNER | SIZE A | DATE 6/3/04 | PART NO. PDL-101 | REV |
| APPROVED | SCALE | RELEASE DATE | WEIGHT | SHEET |

| REVISIONS | | | |
|-----------|-----|-----------|--------|
| ZONE | REV | FINISHES: | GUAGE: |
| | | BP & CP | |

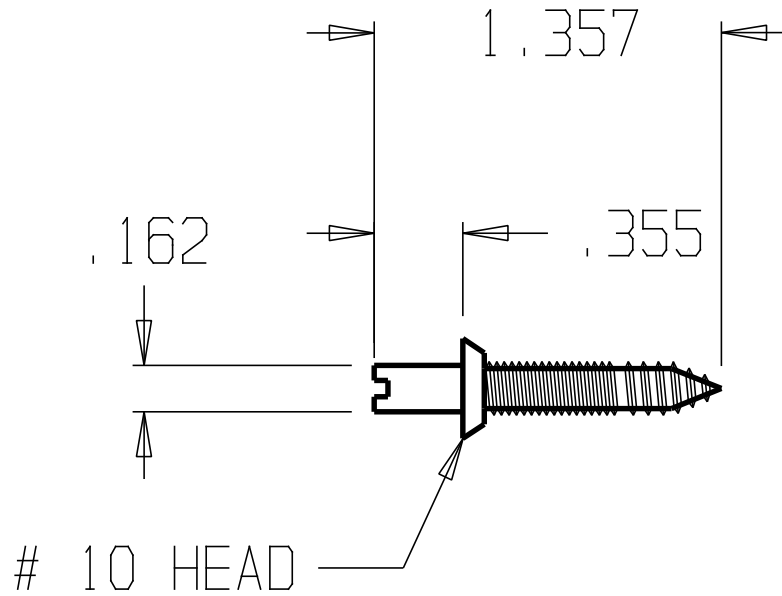

PACKED 2 PER BAG

| | | | | | | | |
|------------------|--|-------|--------------|---------|-------|----------|-----|
| DON-JO MFG. INC. | | | | SIZE | DATE: | PART NO. | REV |
| DESIGNER | | A | 6/3/04 | RHP-100 | | | |
| APPROVED | | SCALE | RELEASE DATE | WEIGHT | SHEET | | |

| REVISIONS | | |
|-----------|-----|--------------------|
| ZONE | REV | FINISHES: |
| | | 605, 609, 612, 630 |
| | | GAUGE: |
| | | 22ga. .032 |

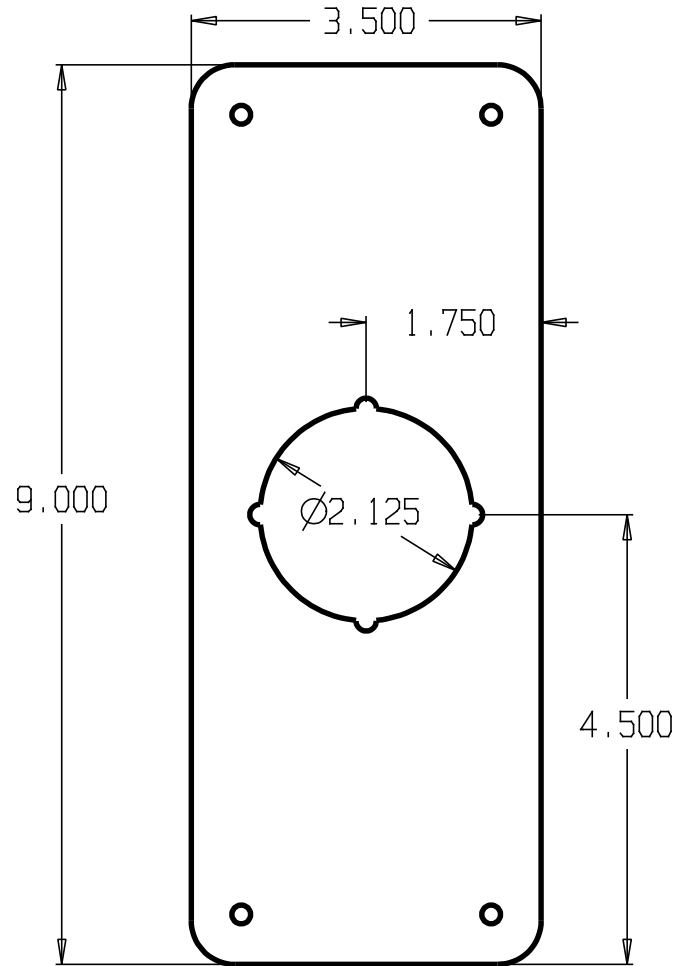

DON-JO MFG. INC.

| | | | | |
|----------|-------|--------------|----------|-------|
| DESIGNER | SIZE | DATE: | PART NO. | REV |
| | A | 6/3/04 | RP-13509 | |
| APPROVED | SCALE | RELEASE DATE | WEIGHT | SHEET |
| | | | | |

| REVISIONS | | |
|-----------|-----|--------------------|
| ZONE | REV | FINISHES: |
| | | 605, 609, 612, 630 |
| | | GAUGE: |
| | | 22ga. .032 |

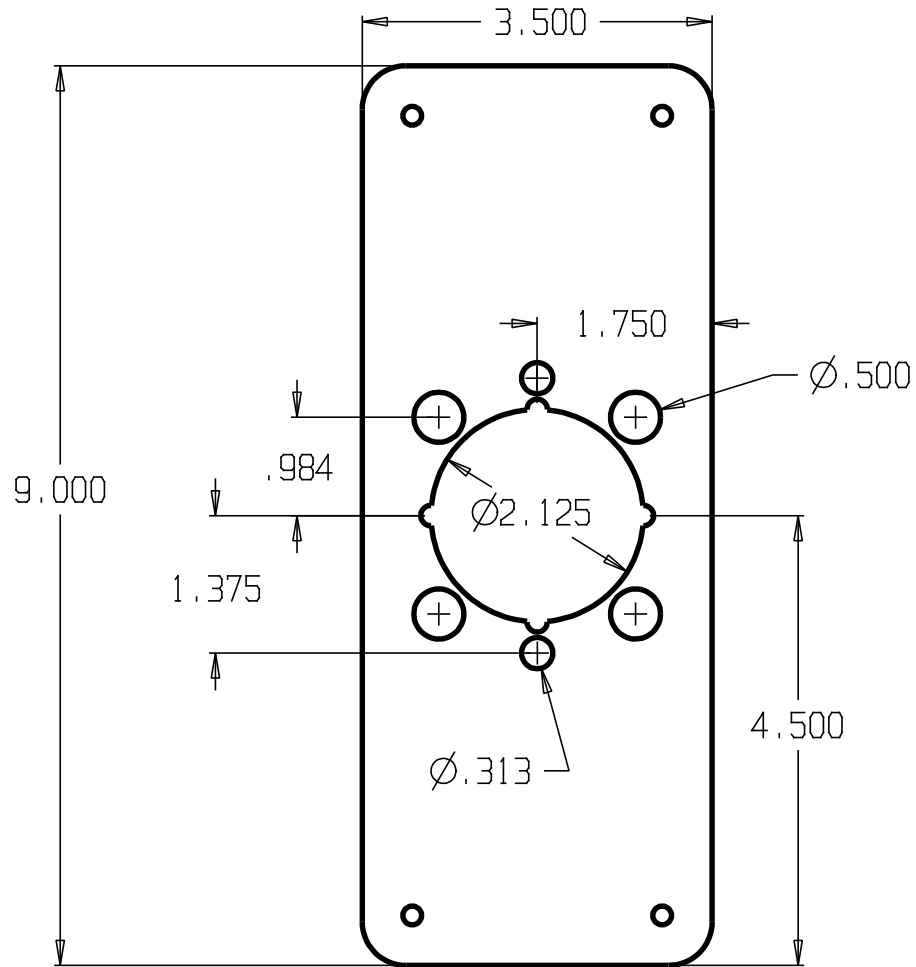

DON-JO MFG. INC.

| | | | | |
|----------|-------|--------------|------------|-------|
| DESIGNER | SIZE | DATE: | PART NO. | REV |
| | A | 6/3/04 | RP-13509-2 | |
| APPROVED | SCALE | RELEASE DATE | WEIGHT | SHEET |
| | | | | |

| REVISIONS | | |
|-----------|-----|--------------------|
| ZONE | REV | FINISHES: |
| | | 605, 609, 612, 630 |
| | | GAUGE: |
| | | 22ga. .032 |

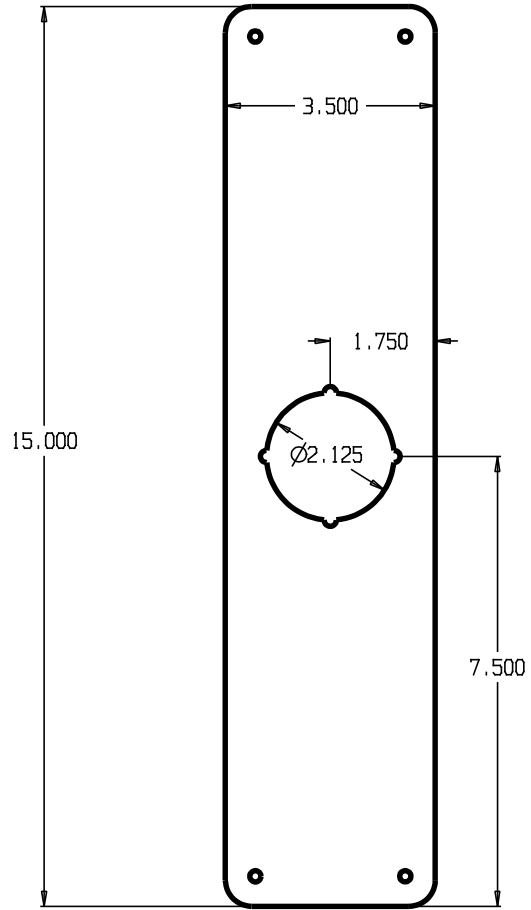

DON-JO MFG. INC.

| | | | | |
|----------|-------|--------------|----------|-------|
| DESIGNER | SIZE | DATE: | PART NO. | REV |
| | A | 6/3/04 | RP-13515 | |
| APPROVED | SCALE | RELEASE DATE | WEIGHT | SHEET |
| | | | | |

| REVISIONS | | |
|-----------|-----|--------------------|
| ZONE | REV | FINISHES: |
| | | 605, 609, 612, 630 |
| | | GAUGE: |
| | | 22ga. .032 |

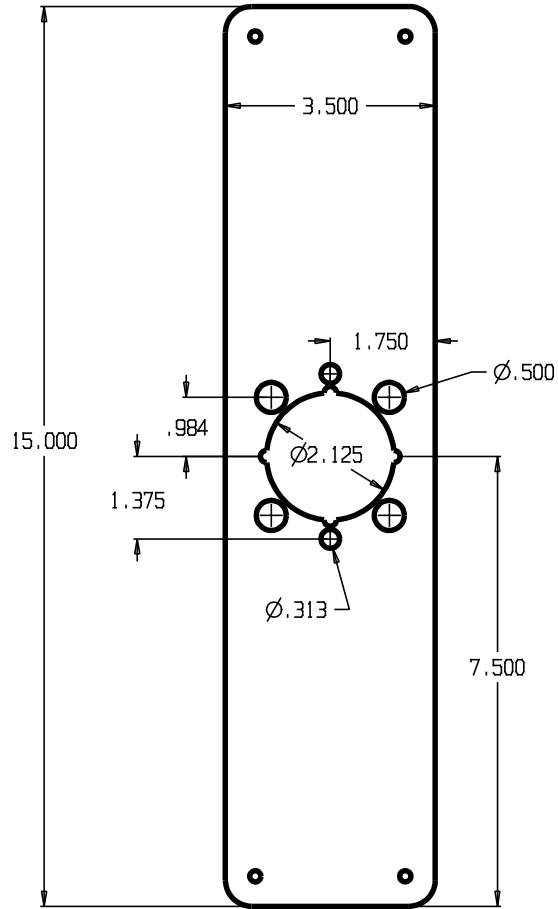

DON-JO MFG. INC.

DESIGNER
APPROVED

SIZE: A
DATE: 6/3/04
SCALE

PART NO. RP-13515-2
RELEASE DATE
WEIGHT
SHEET

| REVISIONS | | |
|-----------|-----|--------------------|
| ZONE | REV | FINISHES: |
| | | 605, 609, 612, 630 |
| | | GAUGE: |
| | | 22ga. .032 |

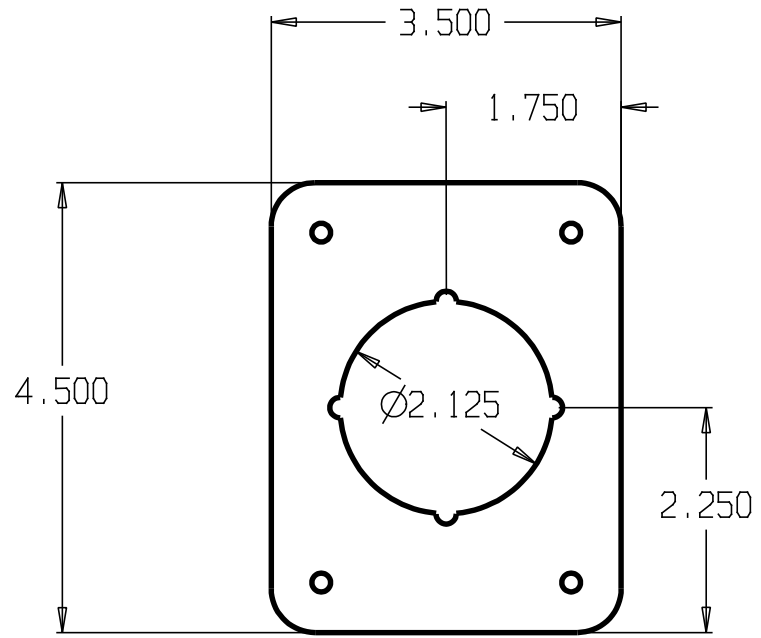

DON-JO MFG. INC.

| | | | | |
|----------|-------|--------------|----------|-------|
| DESIGNER | SIZE | DATE: | PART NO. | REV |
| | A | 6/3/04 | RP-13545 | |
| APPROVED | SCALE | RELEASE DATE | WEIGHT | SHEET |
| | | | | |

| REVISIONS | | |
|-----------|-----|--------------------|
| ZONE | REV | FINISHES: |
| | | 605, 609, 612, 630 |
| | | GAUGE: |
| | | 22ga. .032 |

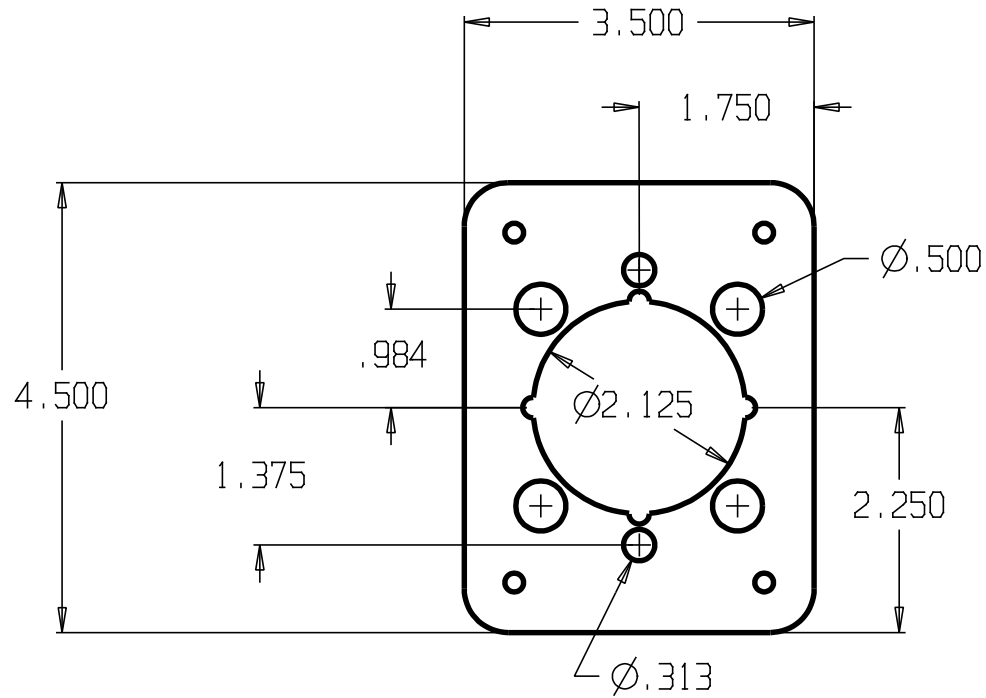

DON-JO MFG. INC.

DESIGNER
APPROVED

| | | | |
|-----------|-----------------|------------------------|-------|
| SIZE A | DATE: 6/3/04 | PART NO. RP-13545-2 | REV |
| SCALE | RELEASE DATE | WEIGHT | SHEET |

| REVISIONS | | | | |
|-----------|-----|------------|------|----------|
| ZONE | REV | FINISHES : | DATE | APPROVED |
| | | | | |

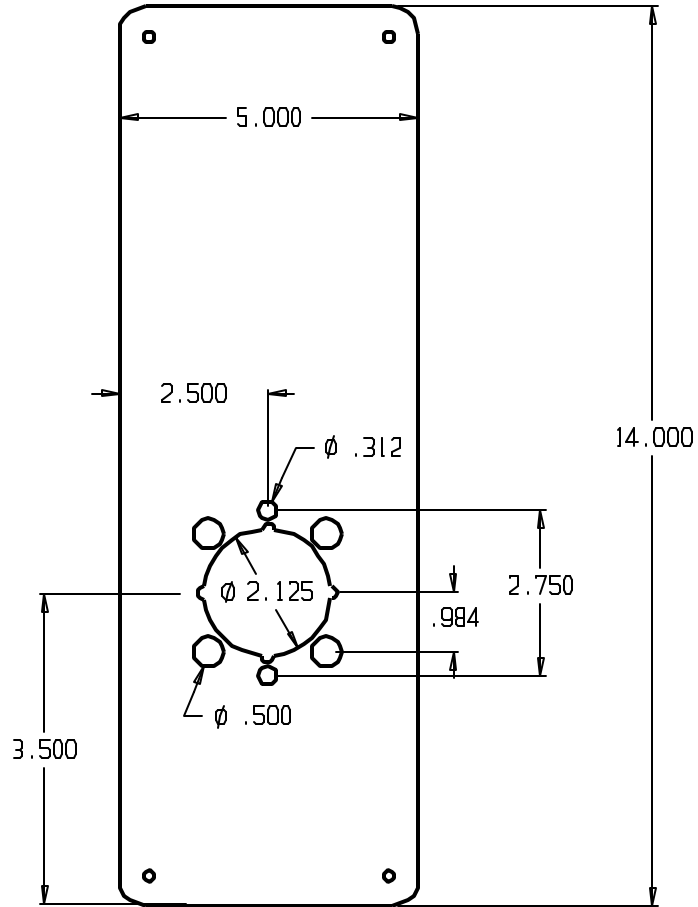

DON-JO MFG. INC.

| | |
|----------|--|
| DESIGNER | |
| APPROVED | |

| | | | |
|-------|--------------|----------|-------|
| SIZE | DATE | PART NO. | REV |
| A | 5/18/10 | RP-14-2 | |
| SCALE | RELEASE DATE | WEIGHT | SHEET |

| REVISIONS | | | |
|-----------|-----|------------|----------|
| ZONE | REV | FINISHES : | GALIGE : |
| | | | |

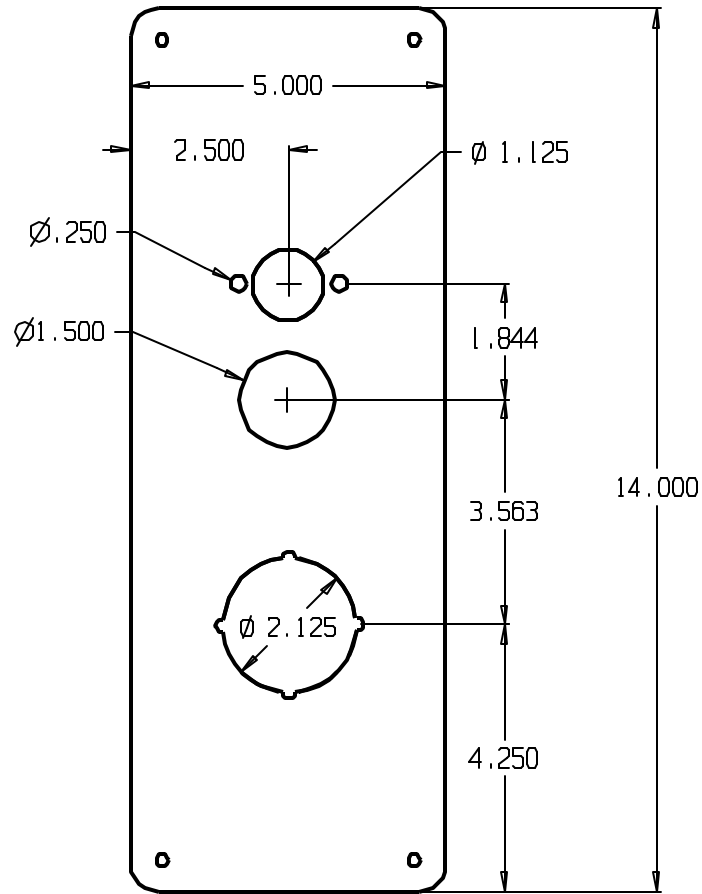

DON-JO MFG. INC.

| | | | | |
|----------|-----------|-----------------|-------------------|-------|
| DESIGNER | SIZE A | DATE 5/18/10 | PART NO. RP 15 | REV |
| APPROVED | SCALE | RELEASE DATE | WEIGHT | SHEET |

| REVISIONS | | | |
|-----------|-----|------------|----------|
| ZONE | REV | FINISHES : | GALUGE : |
| | | | |

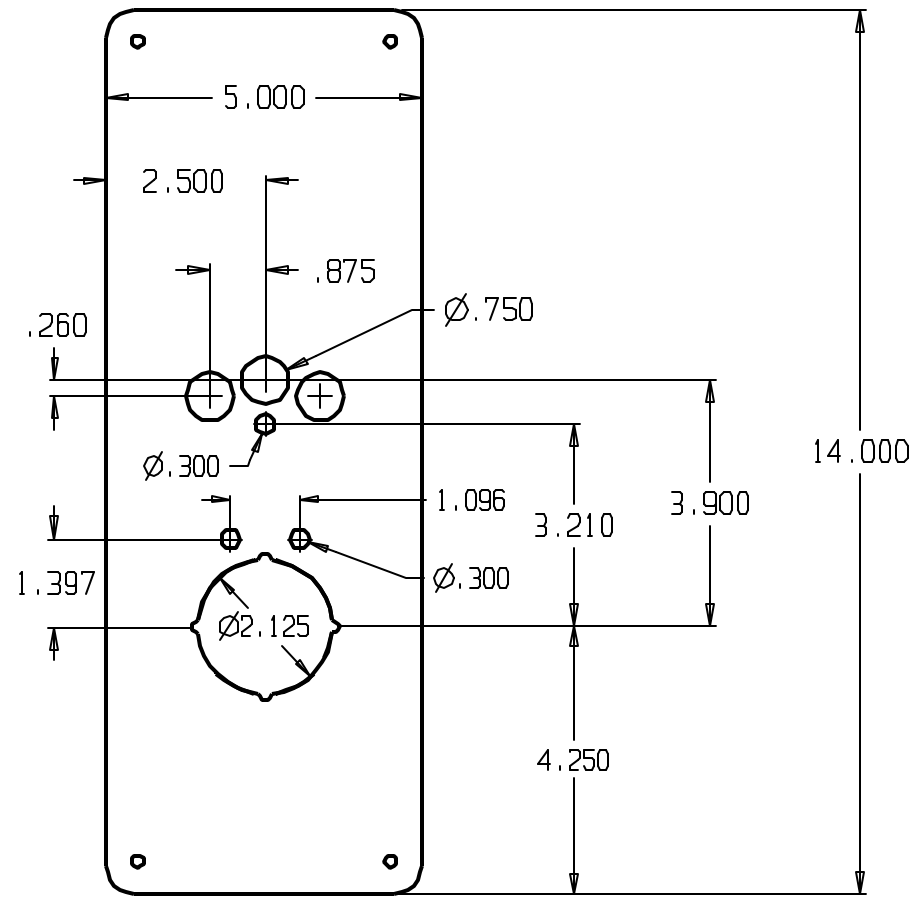

| | | | | | |
|------------------|--|-------|--------------|----------|-------|
| DON-JO MFG. INC. | | SIZE | DATE | PART NO. | REV |
| DESIGNER | | A | 5/18/10 | RP 18 | |
| APPROVED | | SCALE | RELEASE DATE | WEIGHT | SHEET |

| REVISIONS | | | |
|-----------|-----|---------------------|------------|
| ZONE | REV | FINISHES: | GALUGE: |
| | | 605, 630, DURO COAT | 22ga. .032 |

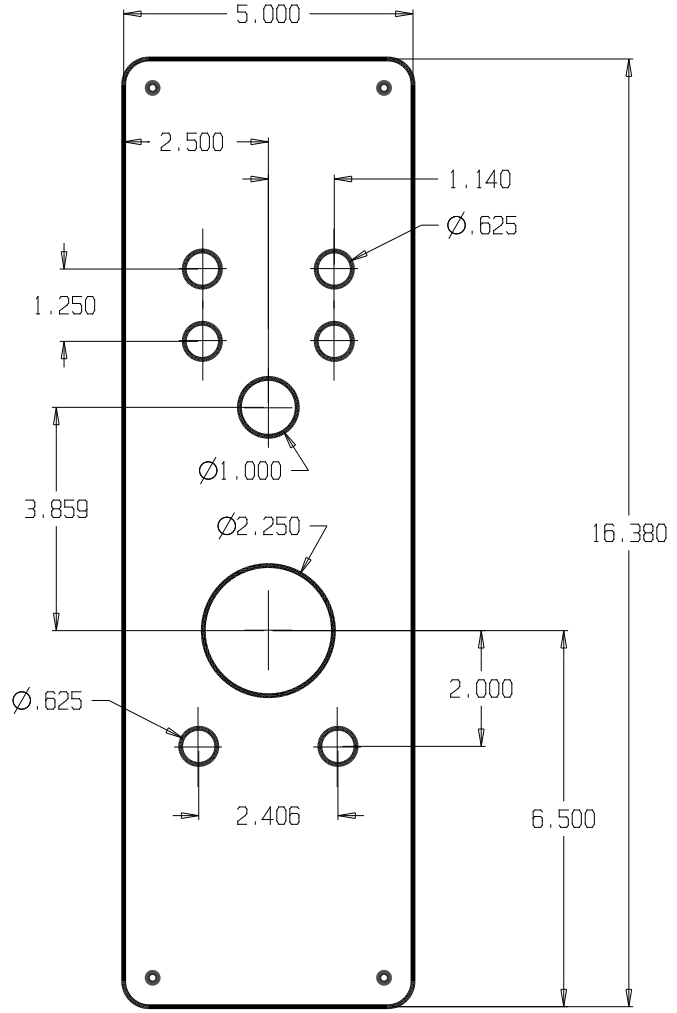

| | | | | | | | |
|-------------------------|------|-------|--------------|--------|---------|----------|-----|
| DON-JO MFG. INC. | | | | SIZE | DATE: | PART NO. | REV |
| DESIGNER | D.R. | | | A | 6/21/13 | RP-26AD | |
| | | SCALE | RELEASE DATE | WEIGHT | SHEET | | |

| REVISIONS | | |
|-----------|-----|----------------------|
| ZONE | REV | FINISHES: |
| | | 605, 630 , DURO COAT |
| | | GAUGE: |
| | | 22ga. .032 |

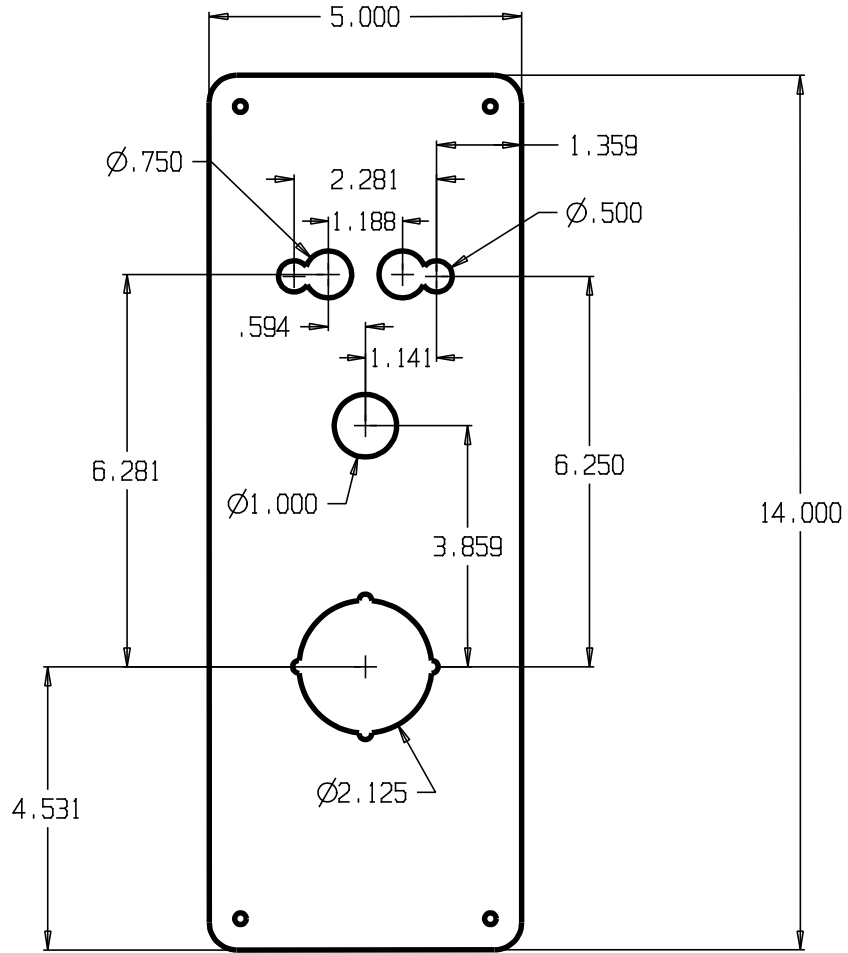

DON-JO MFG. INC.

2011 PER SCHLAGE REV. 6/11-A

| | | | |
|----------|--------------|----------|-------|
| DESIGNER | DATE: | PART NO. | REV |
| D.R. | 6/19/12 | RP-26CO | |
| SCALE | RELEASE DATE | WEIGHT | SHEET |
| | | | |

| REVISIONS | | | |
|-----------|-----|-----------|---------|
| ZONE | REV | FINISHES: | GALUGE: |
| | | | |

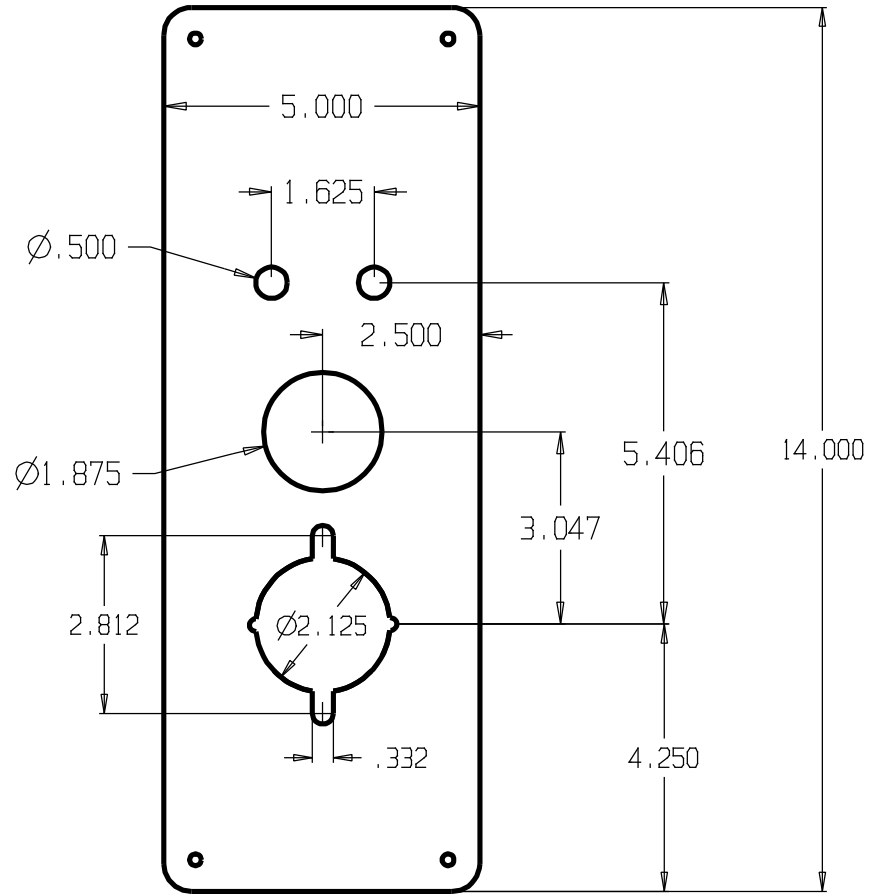

DON-JO MFG. INC.

| | | | | | |
|----------|--|-----------|------------------|-------------------|-------|
| DESIGNER | | SIZE A | DATE: 2/17/12 | PART NO. RP 27 | REV |
| APPROVED | | SCALE | RELEASE DATE | WEIGHT | SHEET |

| REVISIONS | | |
|-----------|-----|--------------------|
| ZONE | REV | FINISHES: |
| | | 605, 630 |
| | | GALUGE: 22ga. .032 |

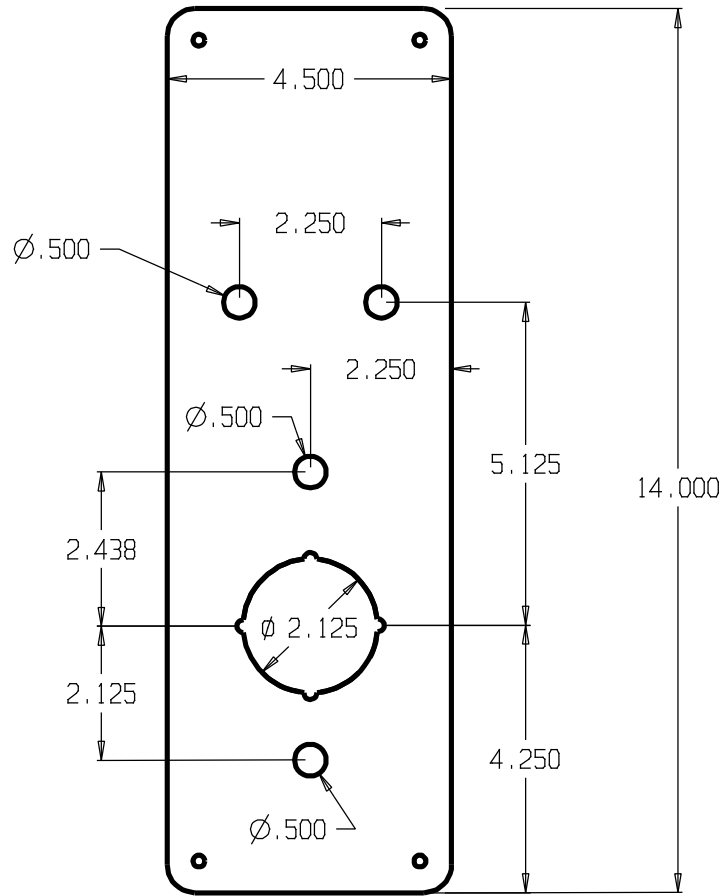

DON-JO MFG. INC.

| | | | | |
|----------|--------------|--------------|----------------------|-----|
| DESIGNER | SCALE | DATE: 6/6/07 | PART NO. RP-E2000-14 | REV |
| APPROVED | RELEASE DATE | WEIGHT | SHEET | |

| REVISIONS | | | |
|-----------|-----|-----------|--------|
| ZONE | REV | FINISHES: | GAUGE: |
| | | 605, 630 | |

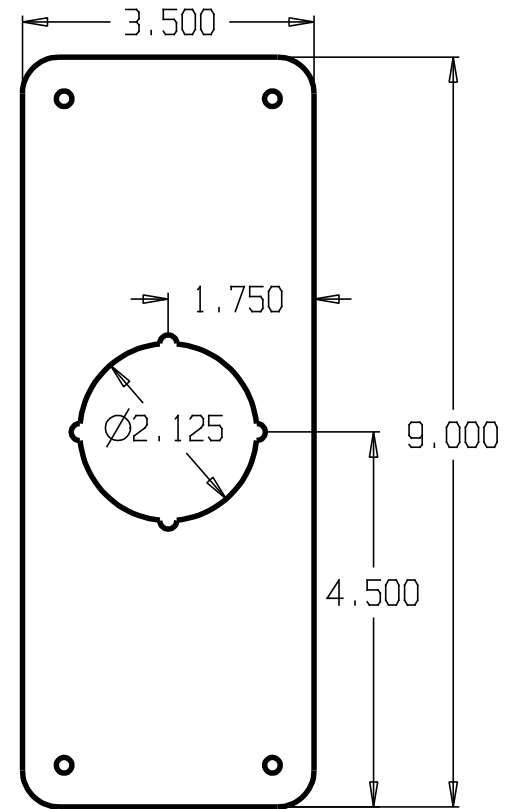
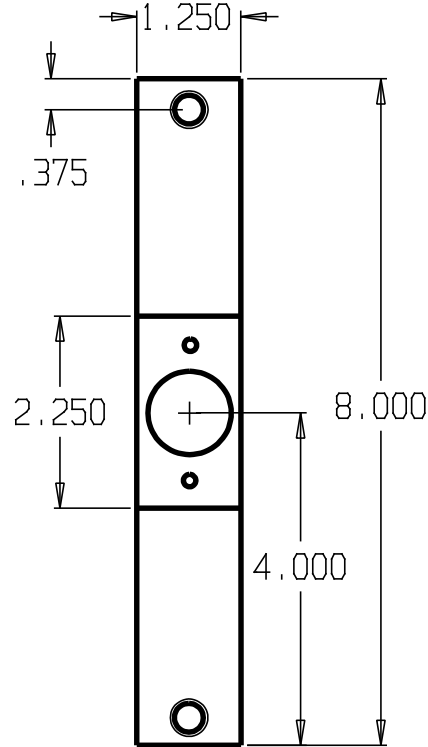
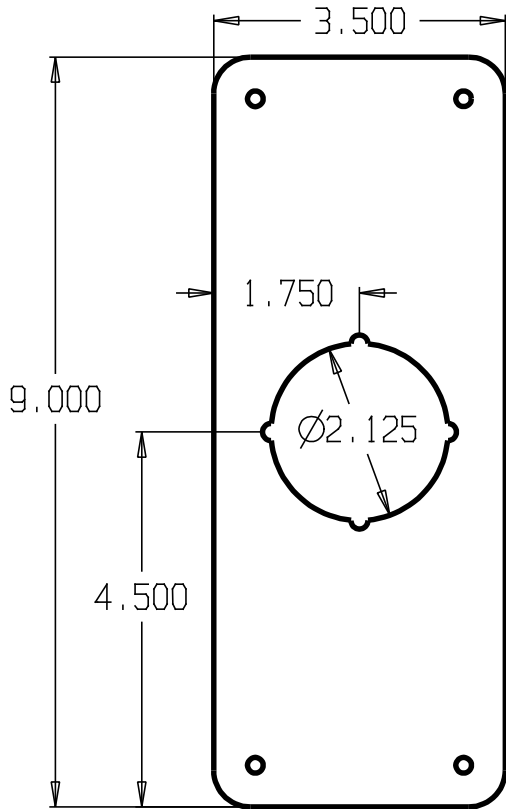

| | | | | | |
|------------------|--|-------|--------------|----------|-------|
| DON-JO MFG. INC. | | SIZE | DATE: | PART NO. | REV |
| DESIGNER | | A | 6/3/04 | RPK-109 | |
| APPROVED | | SCALE | RELEASE DATE | WEIGHT | SHEET |

REVISIONS

| ZONE | REV | FINISHES: | GAUGE: |
|------|-----|--------------------|------------|
| | | 605, 609, 612, 630 | 22ga. .032 |

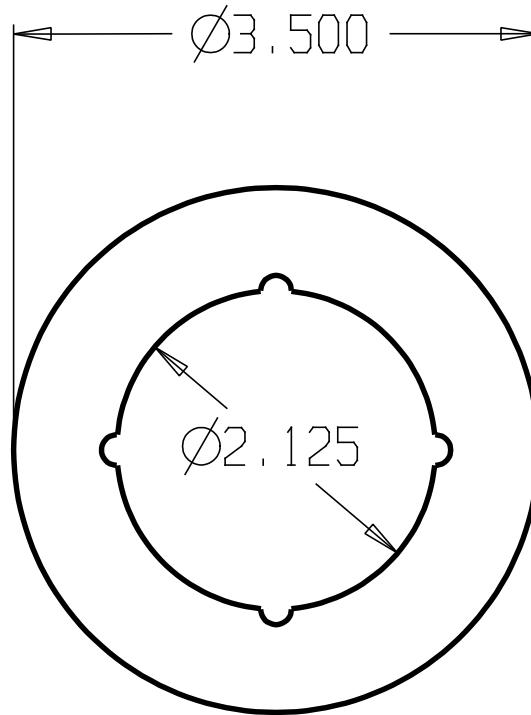

DON-JO MFG. INC.

| | | | | |
|----------|-------|--------------|----------|-------|
| DESIGNER | SIZE | DATE: | PART NO. | REV |
| | A | 6/3/04 | SP-135 | |
| APPROVED | SCALE | RELEASE DATE | WEIGHT | SHEET |
| | | | | |

| REVISIONS | | |
|-----------|-----|-----------|
| ZONE | REV | FINISHES: |
| | | 605, 626 |
| | | GAUGE: |

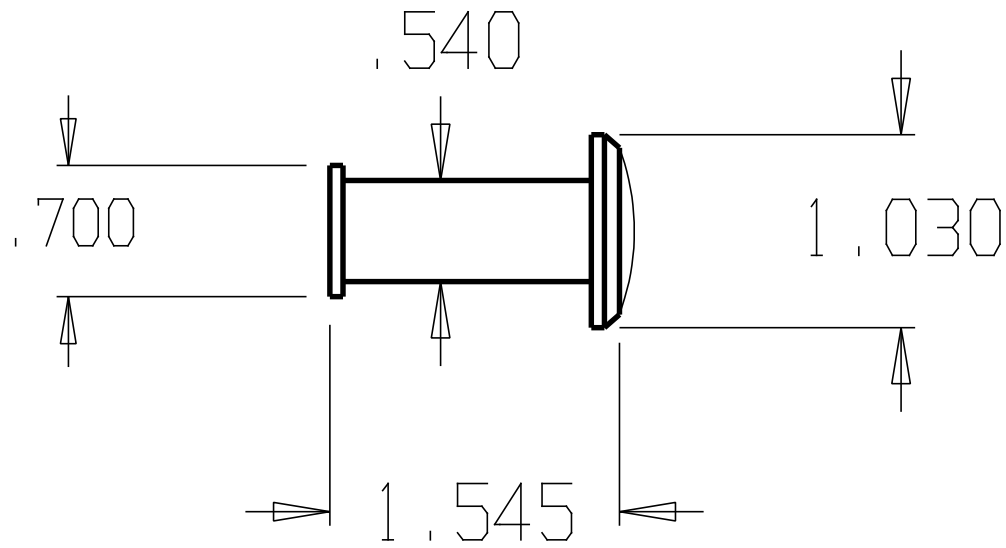

DON-JO MFG. INC.

DESIGNER
APPROVED

| | | | |
|-----------|-----------------|----------------------|-------|
| SIZE A | DATE: 6/4/04 | PART NO. ULDV-180 | REV |
| SCALE | RELEASE DATE | WEIGHT | SHEET |

| | | |
|--------|----|-----|
| DWG NO | SH | REV |
|--------|----|-----|

| REVISIONS | | |
|-----------|-----|--------------------|
| ZONE | REV | FINISHES: 605, 626 |
| | | GAUGE: |

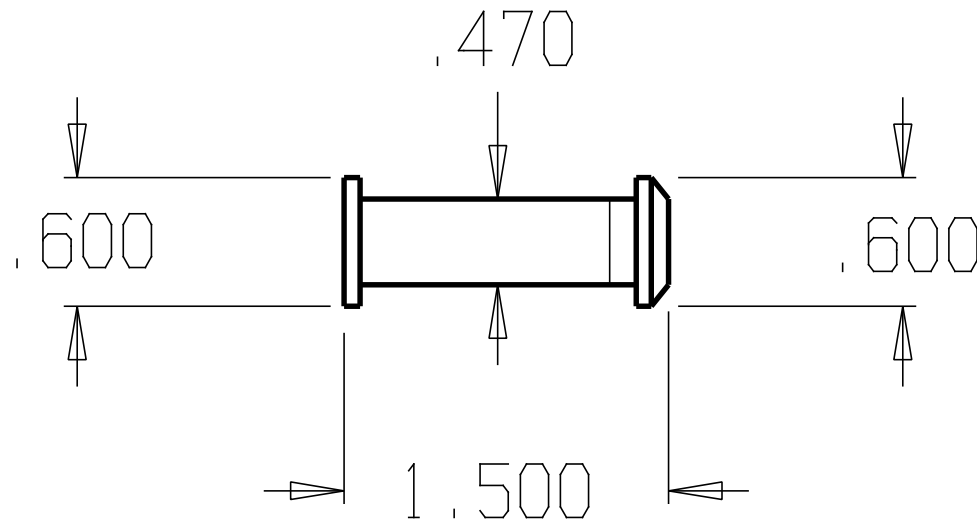

DON-JO MFG. INC.

| | |
|----------|--|
| DESIGNER | |
| APPROVED | |

| | |
|-------|--------------|
| SIZE | DATE: |
| A | 6/4/04 |
| SCALE | RELEASE DATE |

| | |
|----------|-------|
| PART NO. | REV |
| ULDV-90 | |
| WEIGHT | SHEET |

| REVISIONS | | |
|-----------|-----|-------------|
| ZONE | REV | FINISHES: |
| | | ZINC PLATED |
| | | GAUGE: |

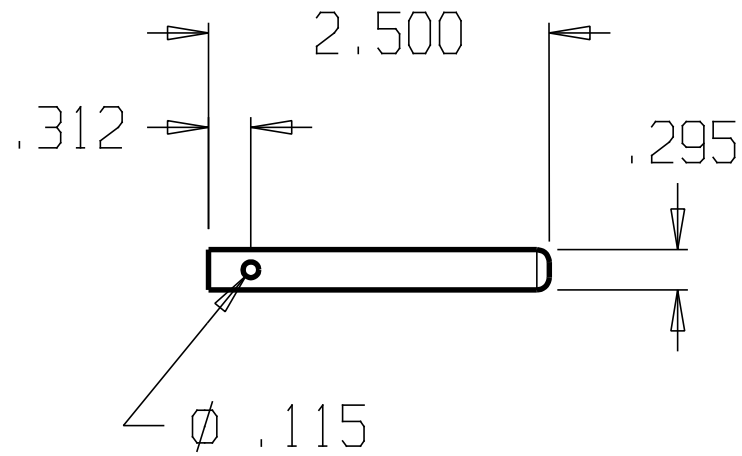
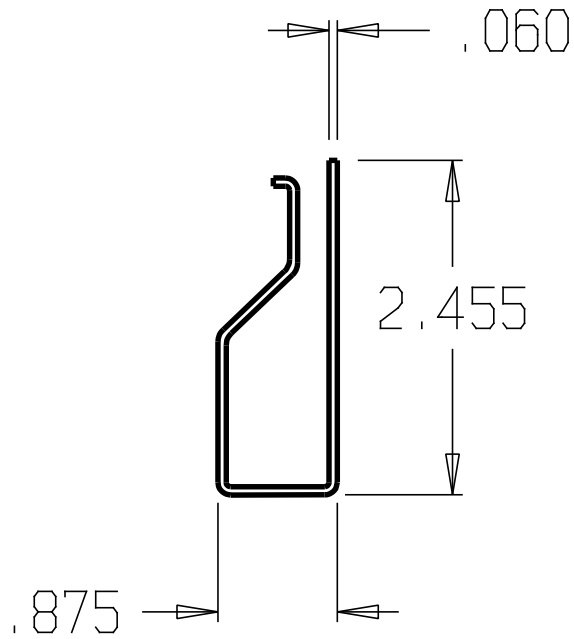

DON-JO MFG. INC.

DESIGNER
APPROVED

SIZE: A
SCALE

DATE: 6/4/04

PART NO. WB-112
WEIGHT
SHEET

REV

| REVISIONS | | | |
|-----------|-----|-----------------|--------|
| ZONE | REV | FINISHES: | GAUGE: |
| | | 605, 626, CLEAR | |

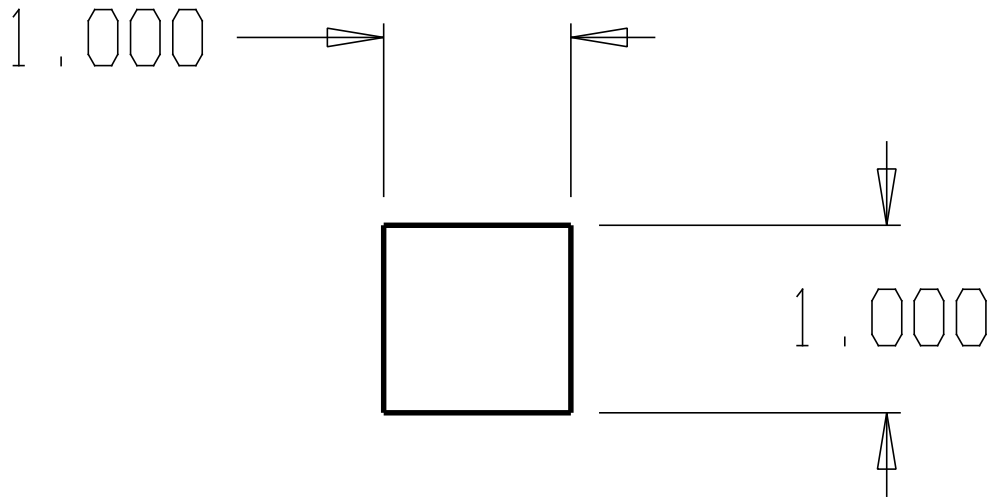

DON-JO MFG. INC.

| | |
|----------|--|
| DESIGNER | |
| APPROVED | |

| | | | |
|-------|--------------|----------|-------|
| SIZE | DATE: | PART NO. | REV |
| A | 6/4/04 | WP-34 | |
| SCALE | RELEASE DATE | WEIGHT | SHEET |

| REVISIONS | | | |
|-----------|-----|-----------|----------|
| ZONE | REV | FINISHES: | DATE |
| | | SL & DU | |
| | | DATE | APPROVED |

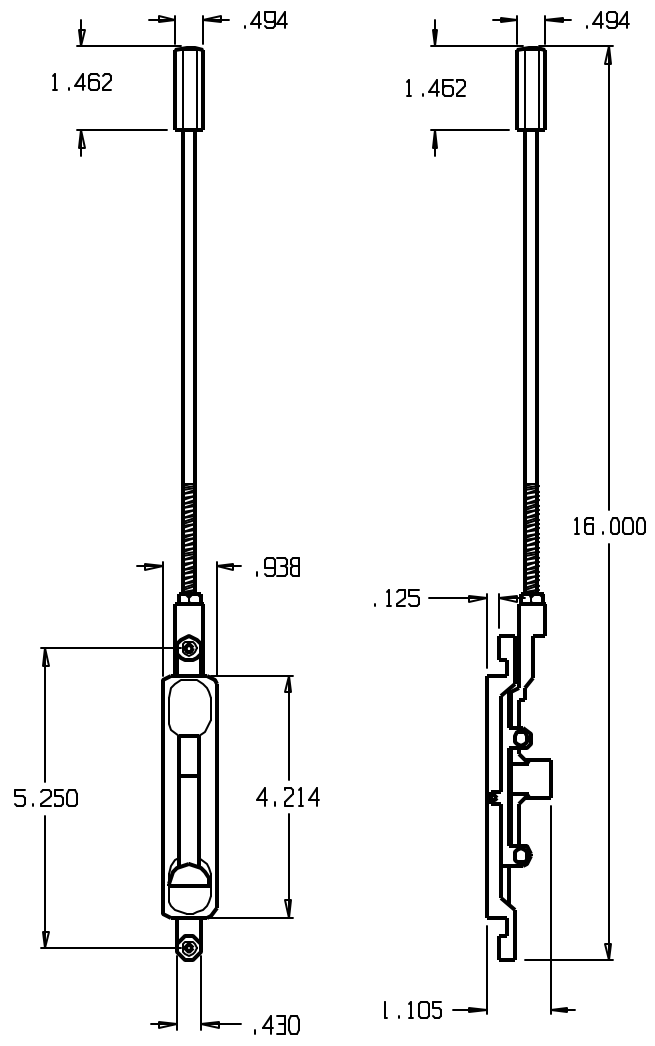
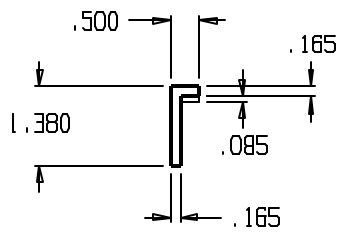
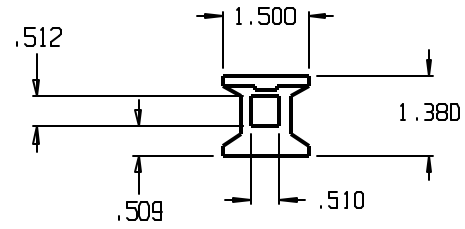

DON-JO MFG. INC.

| | | | | |
|----------|---------|---------------|-----------------|-------|
| DESIGNER | SIZE: A | DATE: 3/25/04 | PART NO.: #1550 | REV |
| APPROVED | SCALE | RELEASE DATE | WEIGHT | SHEET |

| REVISIONS | | | | |
|-----------|-----|-----------|------|----------|
| ZONE | REV | FINISHES: | DATE | APPROVED |
| | | SL & DU | | |

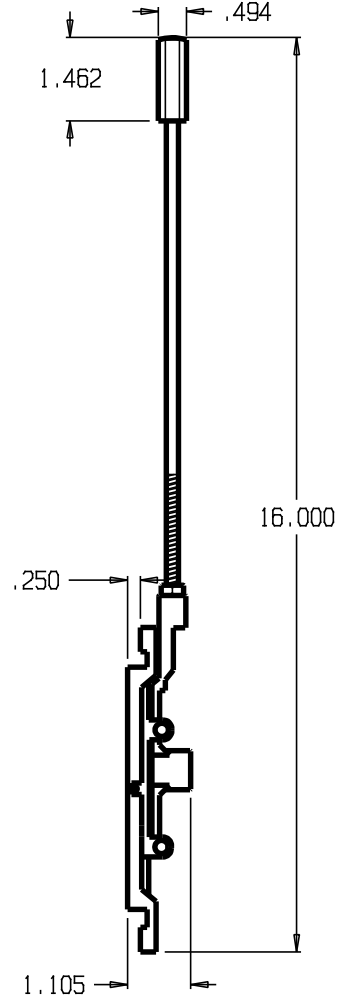
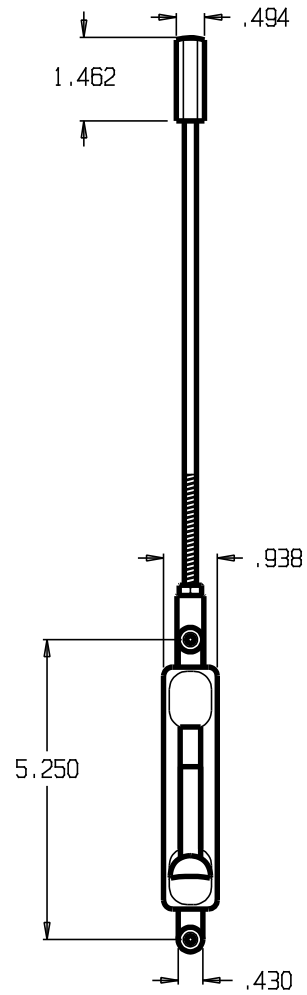
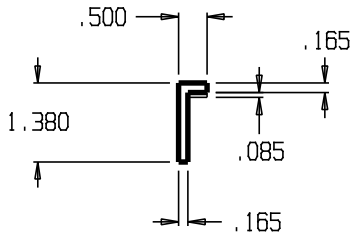
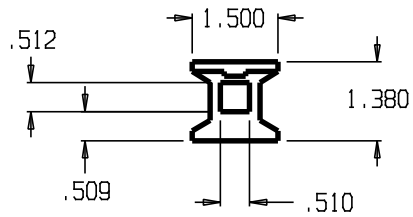

DON-JO MFG. INC.

| | | | | |
|----------|-----------|------------------|-------------------|-------|
| DESIGNER | SIZE A | DATE: 3/25/04 | PART NO. #1551 | REV |
| APPROVED | SCALE | RELEASE DATE | WEIGHT | SHEET |

| REVISIONS | | | | |
|-----------|-----|---------------------|------|----------|
| ZONE | REV | FINISHES: | DATE | APPROVED |
| | | 605,612,613,625,626 | | |

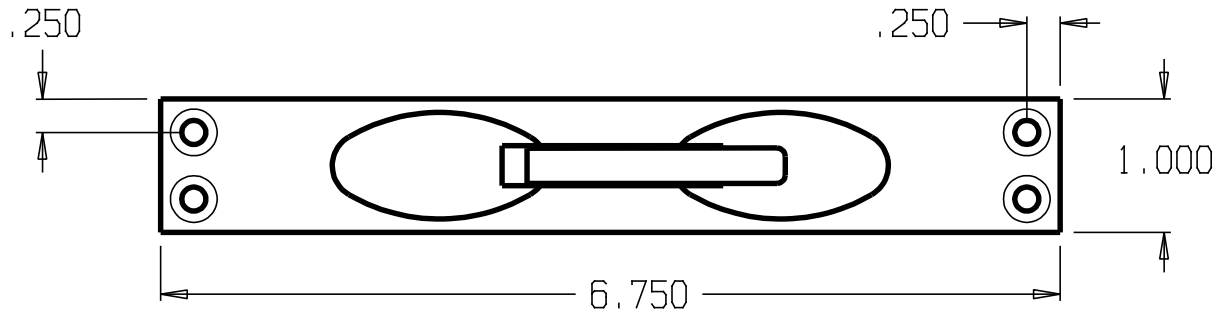
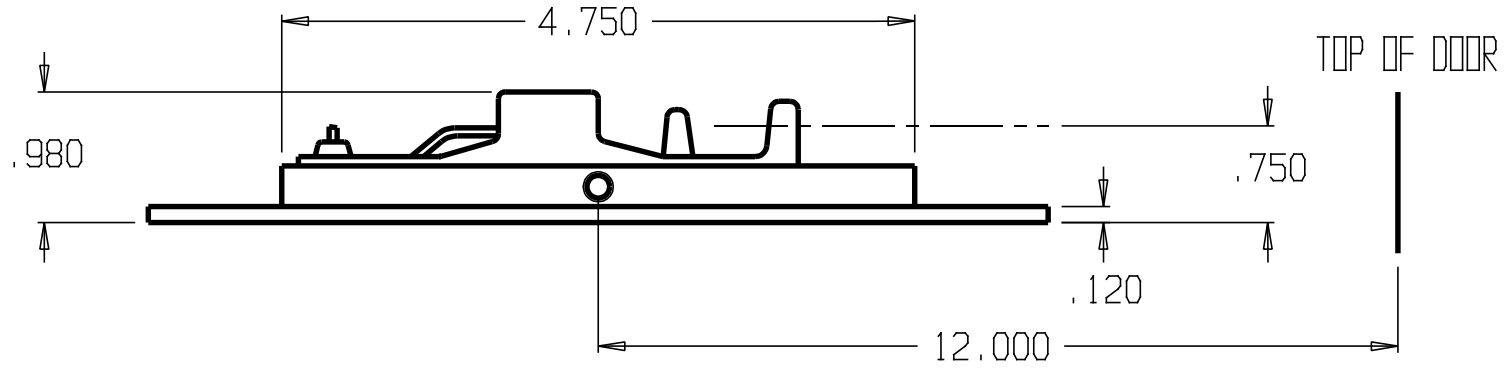

FOR ANSI A115.4-1981

DON-JO MFG. INC.

| | | | | |
|----------|-----------|------------------|-------------------|-------|
| DESIGNER | SIZE A | DATE: 3/25/04 | PART NO. #1555 | REV |
| APPROVED | SCALE | RELEASE DATE | WEIGHT | SHEET |

| REVISIONS | | | | |
|-----------|-----|---------------------|------|----------|
| ZONE | REV | FINISHES: | DATE | APPROVED |
| | | 605,612,613,625,626 | | |

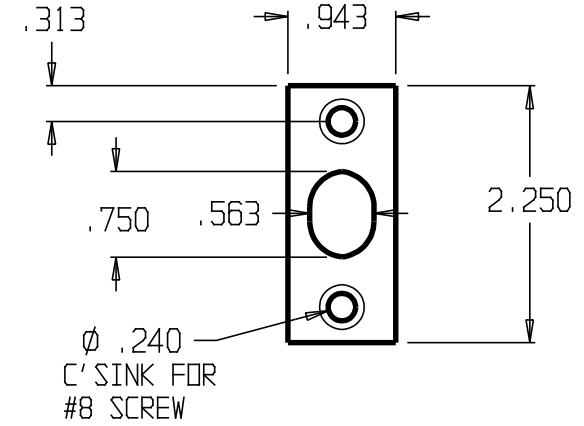
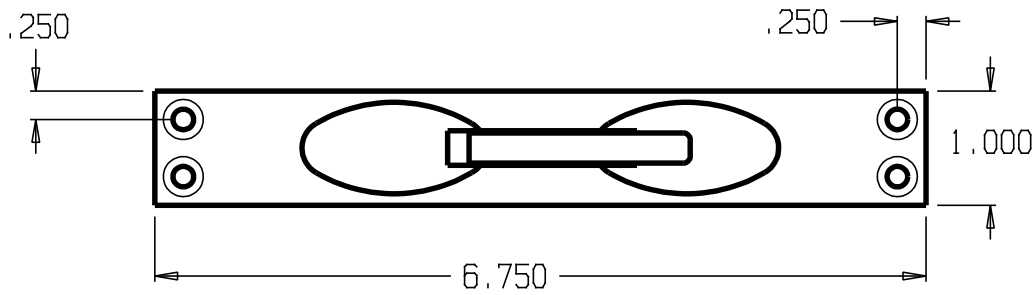
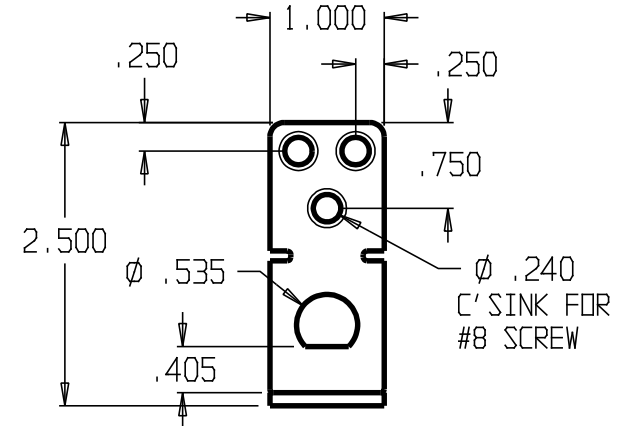
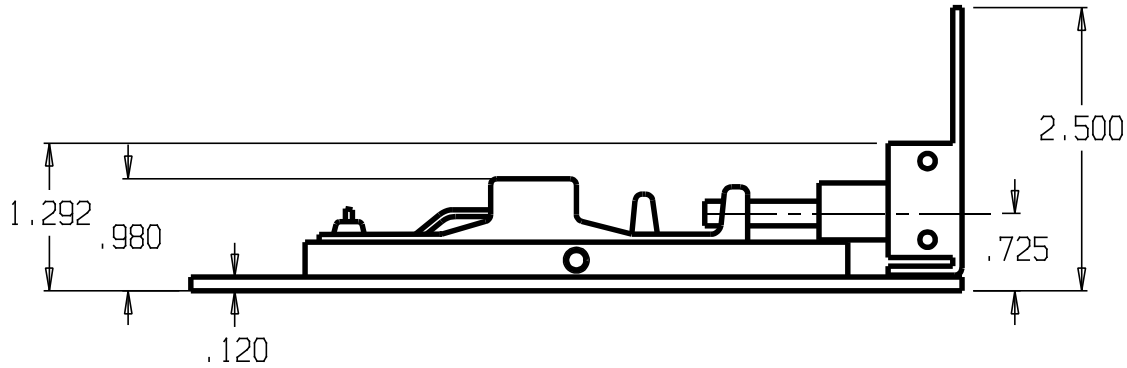

DON-JO MFG. INC.

| | | | | |
|----------|-----------|------------------|-------------------|-------|
| DESIGNER | SIZE A | DATE: 3/25/04 | PART NO. #1557 | REV |
| APPROVED | SCALE | RELEASE DATE | WEIGHT | SHEET |

| REVISIONS | | | |
|-----------|-----|-------------|----------|
| ZONE | REV | FINISHES: | DATE |
| | | 605,613,626 | |
| | | | APPROVED |

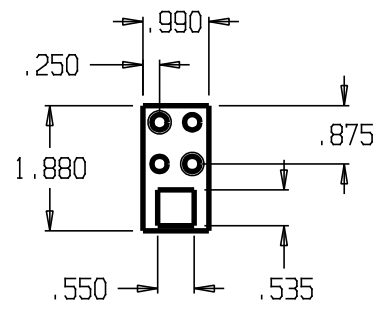
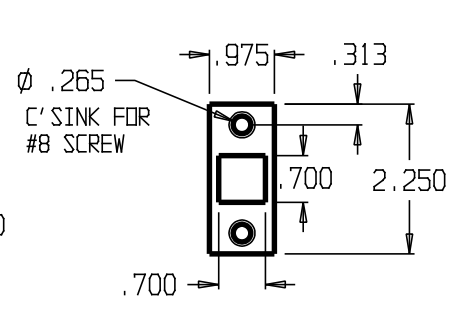
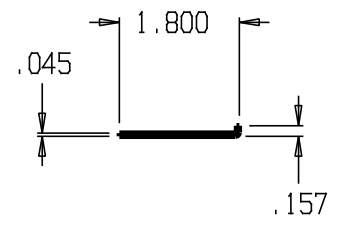
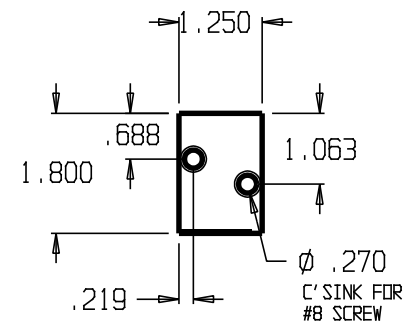
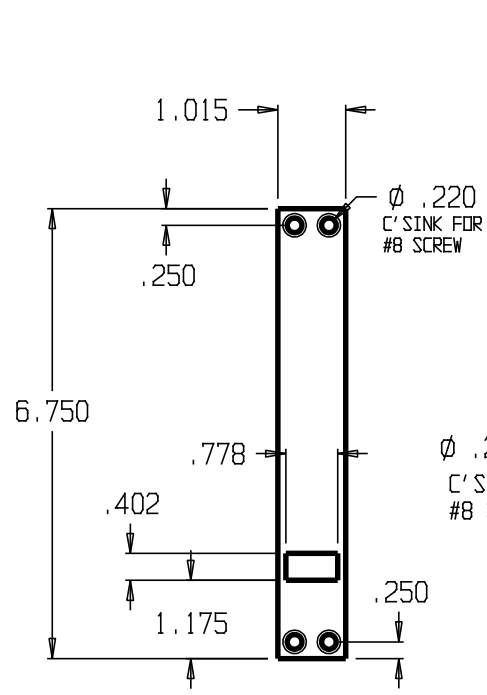
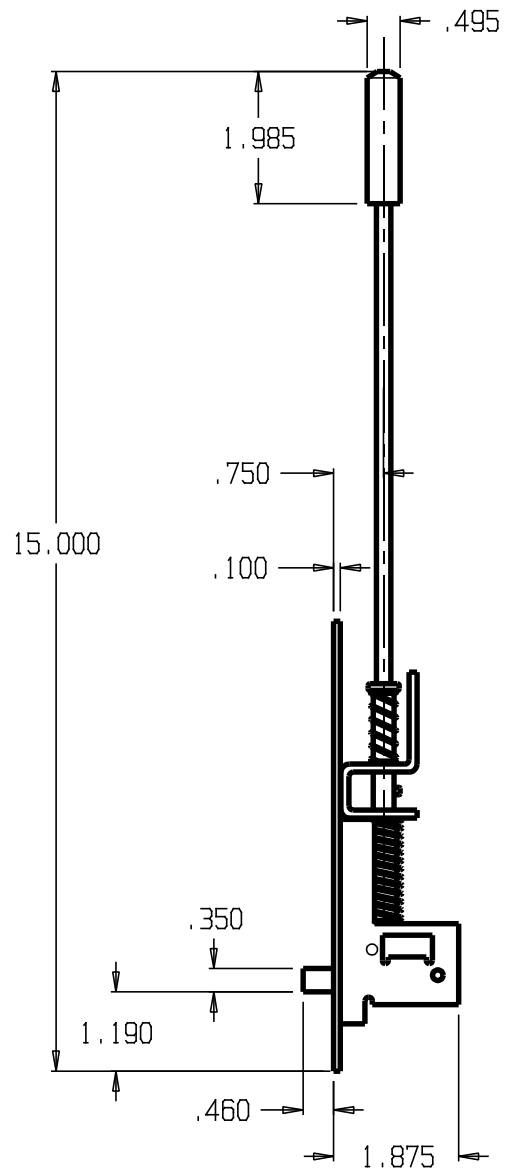

.050 THICK

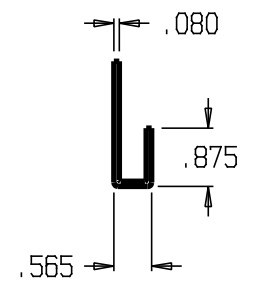

DON-JO MFG. INC.

| | | | | |
|----------|-----------|------------------|-------------------|-------|
| DESIGNER | SIZE A | DATE: 3/25/04 | PART NO. #1560 | REV |
| APPROVED | SCALE | RELEASE DATE | WEIGHT | SHEET |

| REVISIONS | | | |
|-----------|-----|---------------|----------|
| ZONE | REV | FINISHES: | DATE |
| | | 605, 613, 626 | |
| | | | APPROVED |

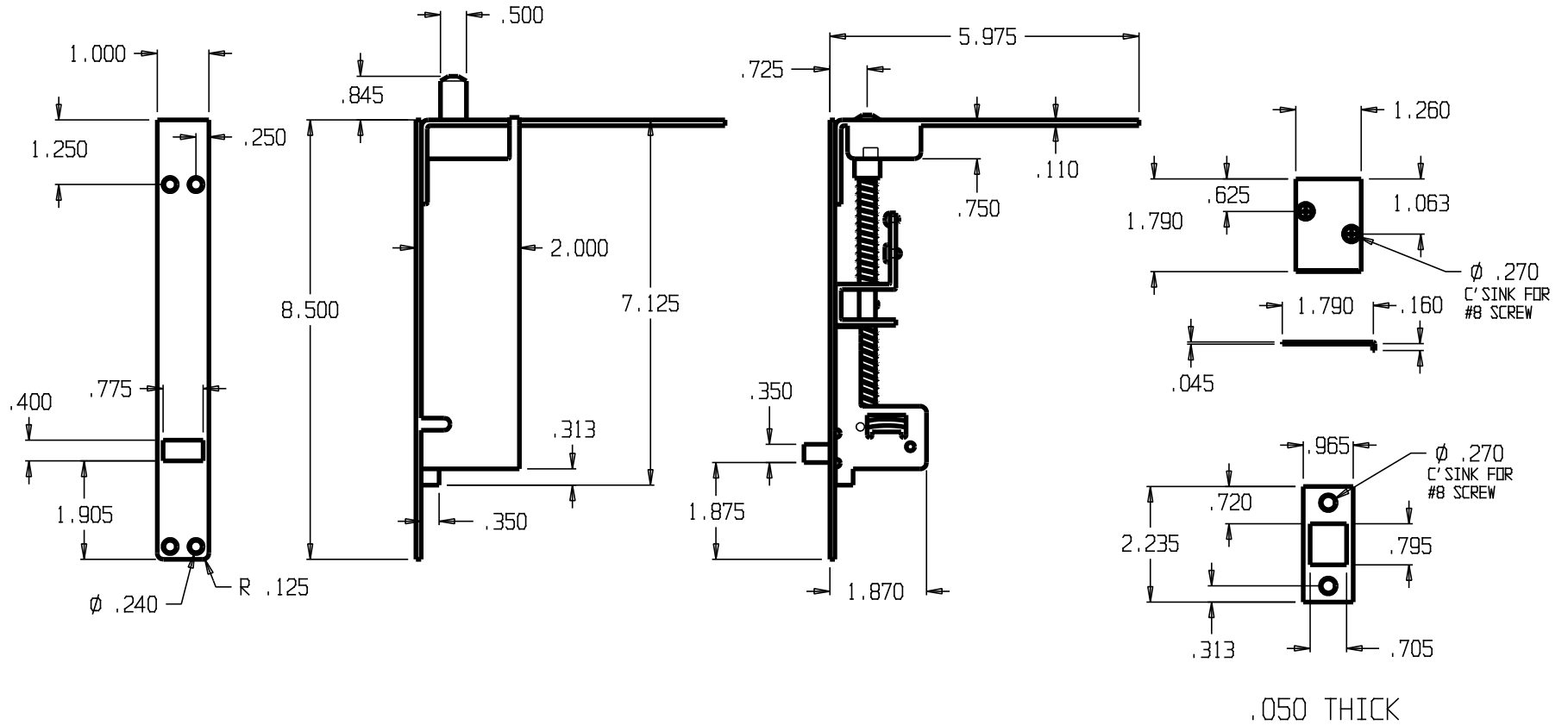

DON-JO MFG. INC.

| | | | | |
|----------|-------|--------------|----------|-------|
| DESIGNER | SIZE | DATE: | PART NO. | REV |
| | A | 3/25/04 | #1562 | |
| APPROVED | SCALE | RELEASE DATE | WEIGHT | SHEET |
| | | | | |

| REVISIONS | | | |
|-----------|-----|-------------|------|
| ZONE | REV | FINISHES: | DATE |
| | | 605,613,626 | |
| | | APPROVED | |

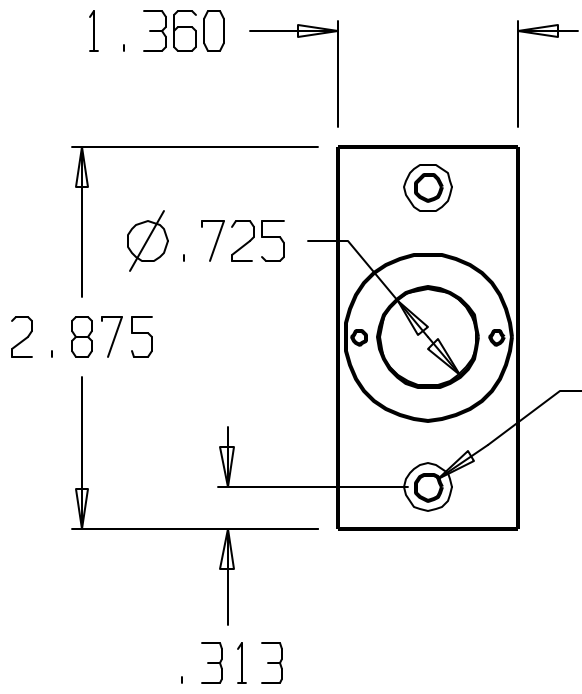

Ø .195
C'SINK FOR
#8 SCREW

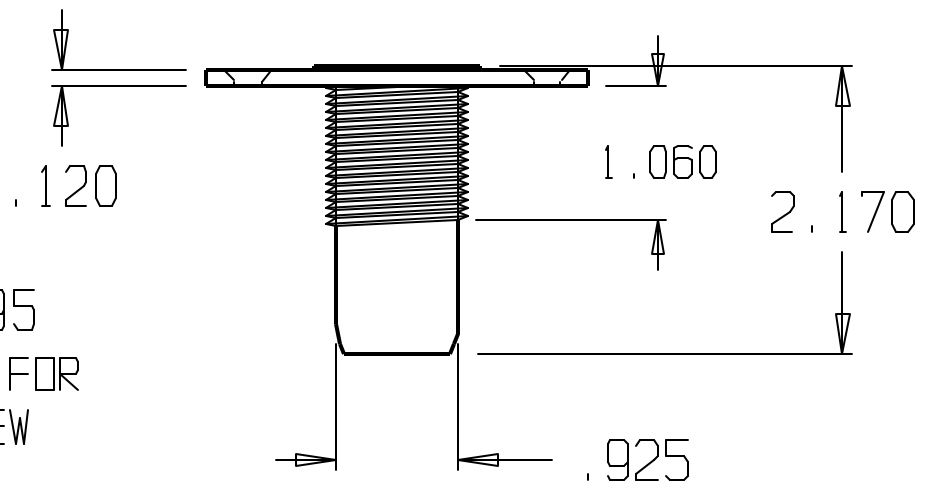

DON-JO MFG. INC.

| | | | | |
|----------|-----------|--------------|-------------------|-------|
| DESIGNER | SIZE A | DATE: | PART NO. #1570 | REV |
| APPROVED | SCALE | RELEASE DATE | WEIGHT | SHEET |

| REVISIONS | | | |
|-----------|-----|---------------|------|
| ZONE | REV | FINISHES: | DATE |
| | | 605, 613, 626 | |
| | | APPROVED | |

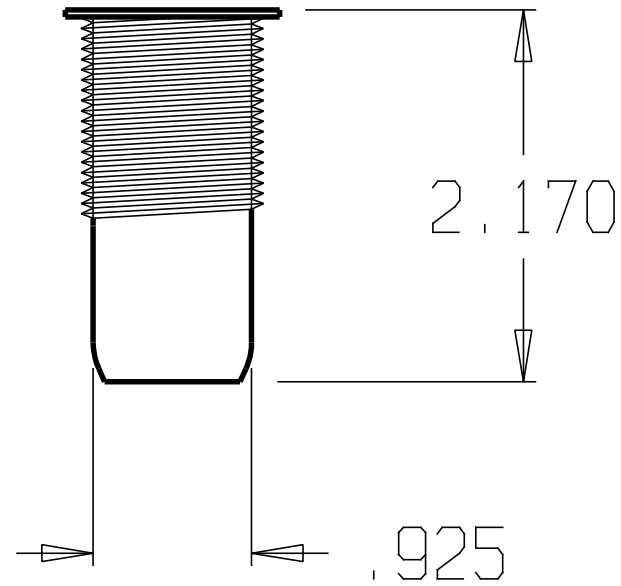
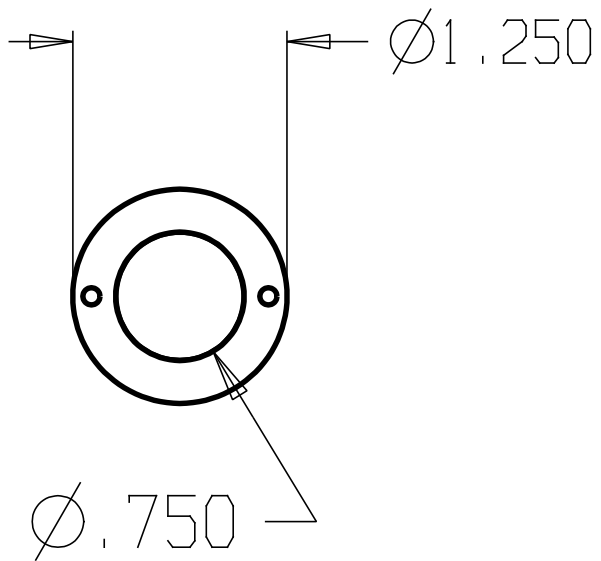

DON-JO MFG. INC.

| | | | | |
|----------|---------|---------------|----------------|-------|
| DESIGNER | SIZE: A | DATE: 3/25/04 | PART NO. #1572 | REV |
| APPROVED | SCALE | RELEASE DATE | WEIGHT | SHEET |

| REVISIONS | | | | |
|-----------|-----|-----------|------|----------|
| ZONE | REV | FINISHES: | DATE | APPROVED |
| | | 626 | | |

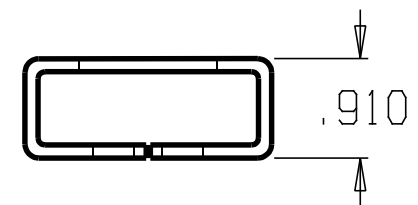
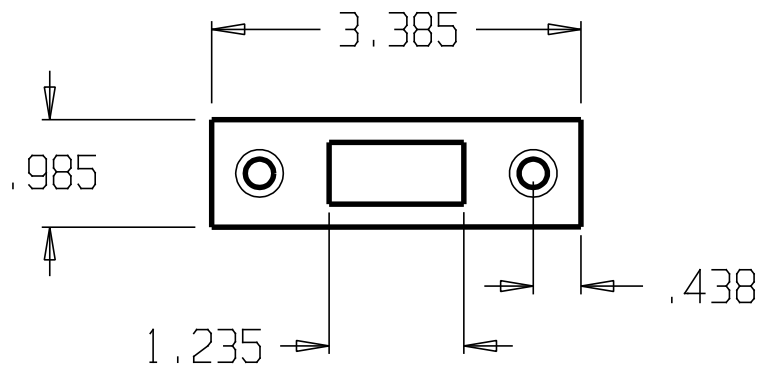
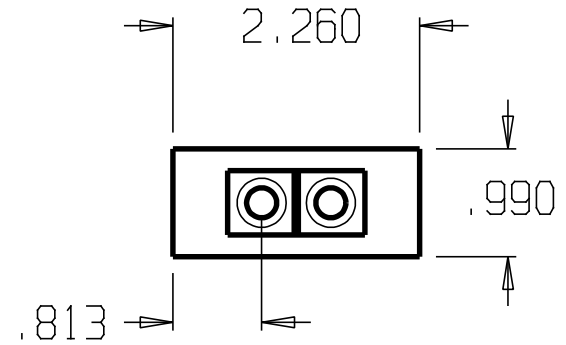
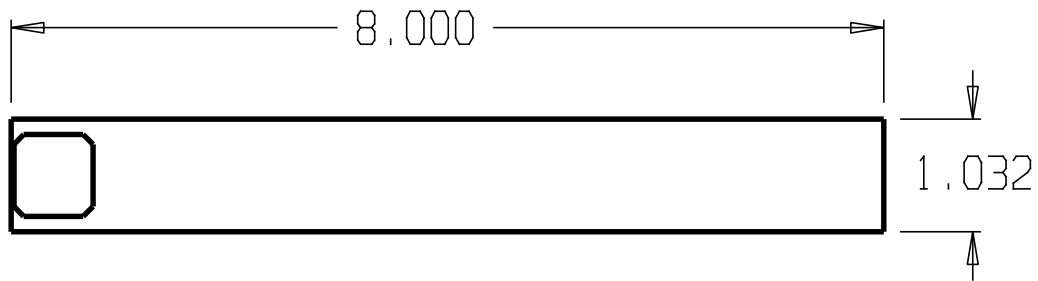

DON-JO MFG. INC.

| | | | | |
|----------|-----------|------------------|-------------------|-------|
| DESIGNER | SIZE A | DATE: 3/25/04 | PART NO. #1578 | REV |
| APPROVED | SCALE | RELEASE DATE | WEIGHT | SHEET |

| REVISIONS | | | |
|-----------|-----|-----------|---------|
| ZONE | REV | FINISHES: | GALIGE: |
| | | 626 | |

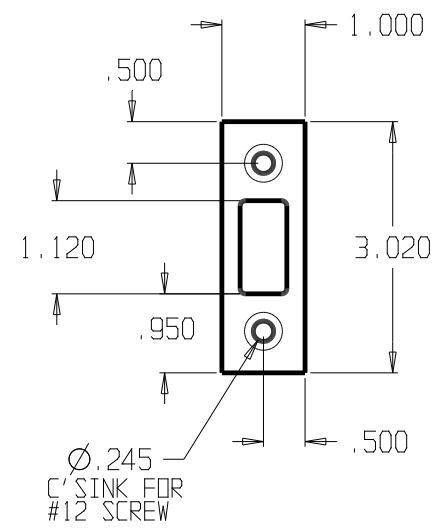
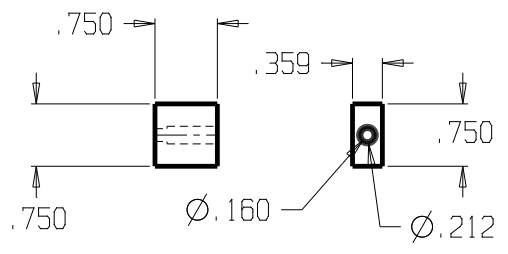
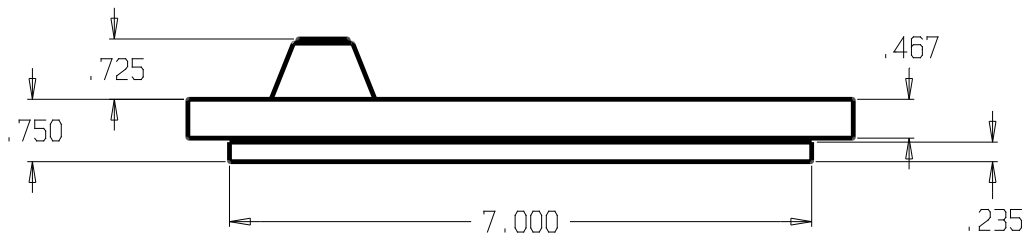
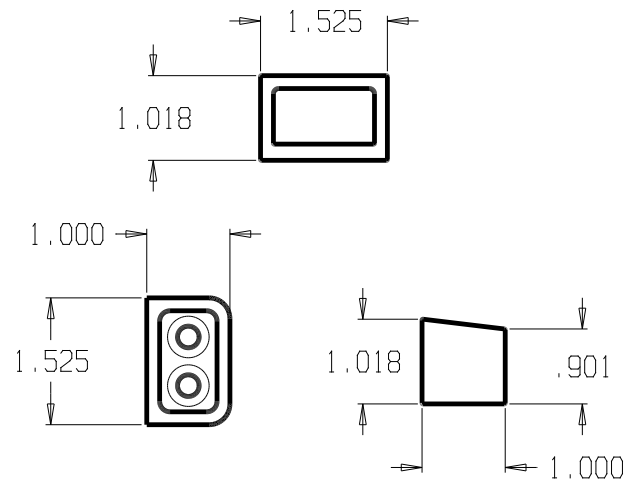
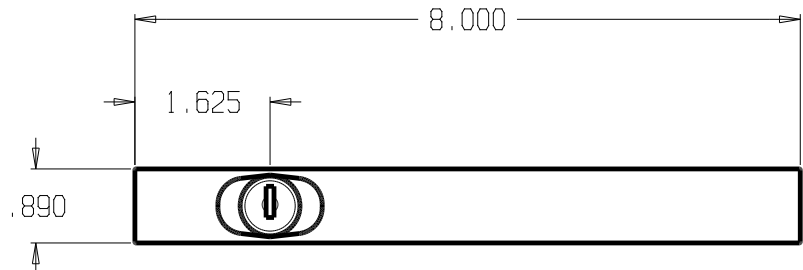

| | | | | | |
|-------------------------|------|-------|--------------|----------|-------|
| DON-JO MFG. INC. | | SIZE | DATE: | PART NO. | REV |
| | | A | 11/22/10 | #1579 | |
| DESIGNER | D.R. | SCALE | RELEASE DATE | WEIGHT | SHEET |

| REVISIONS | | | | |
|-----------|-----|-----------|------|----------|
| ZONE | REV | FINISHES: | DATE | APPROVED |
| | | 626 | | |

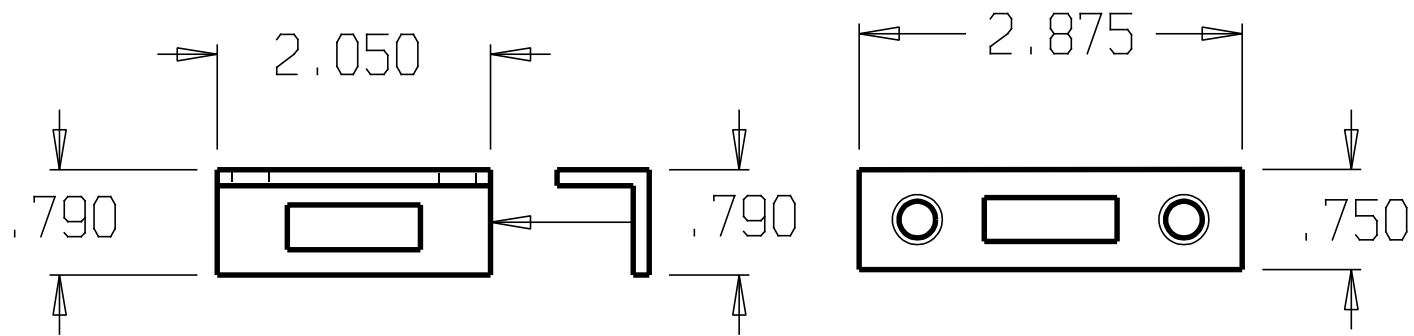
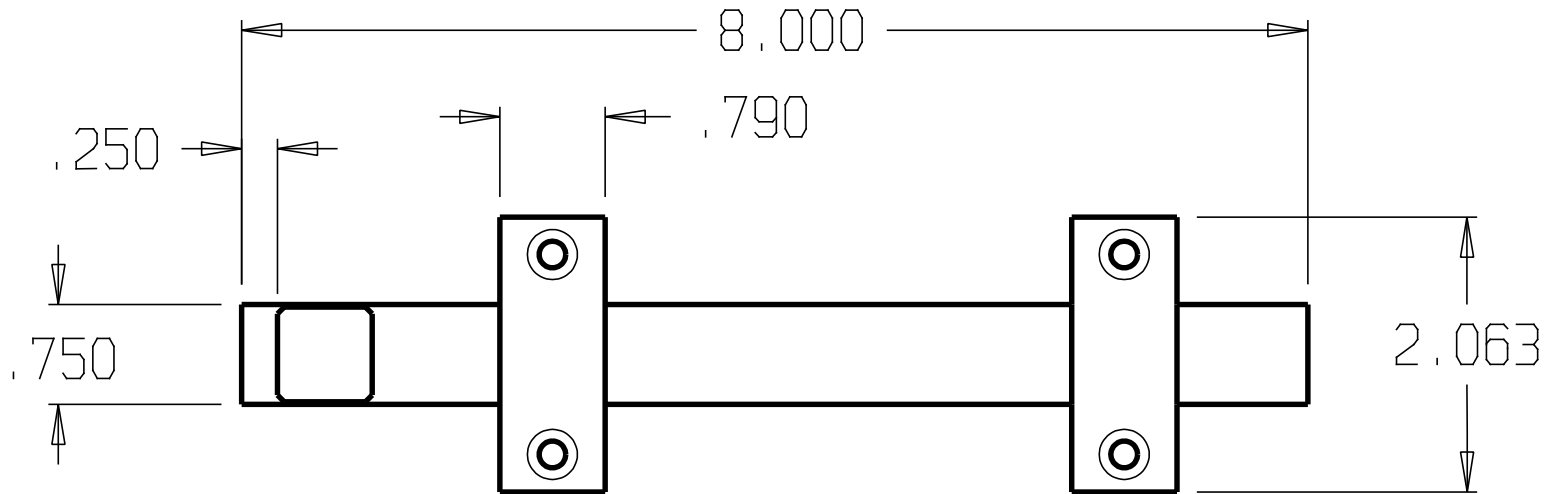

DON-JO MFG. INC.

| | | | | |
|----------|-----------|------------------|-------------------|-------|
| DESIGNER | SIZE A | DATE: 3/25/04 | PART NO. #1580 | REV |
| APPROVED | SCALE | RELEASE DATE | WEIGHT | SHEET |

| REVISIONS | | | | |
|-----------|-----|-------------------------|------|----------|
| ZONE | REV | FINISHES: | DATE | APPROVED |
| | | 605,613,619,620,625,626 | | |

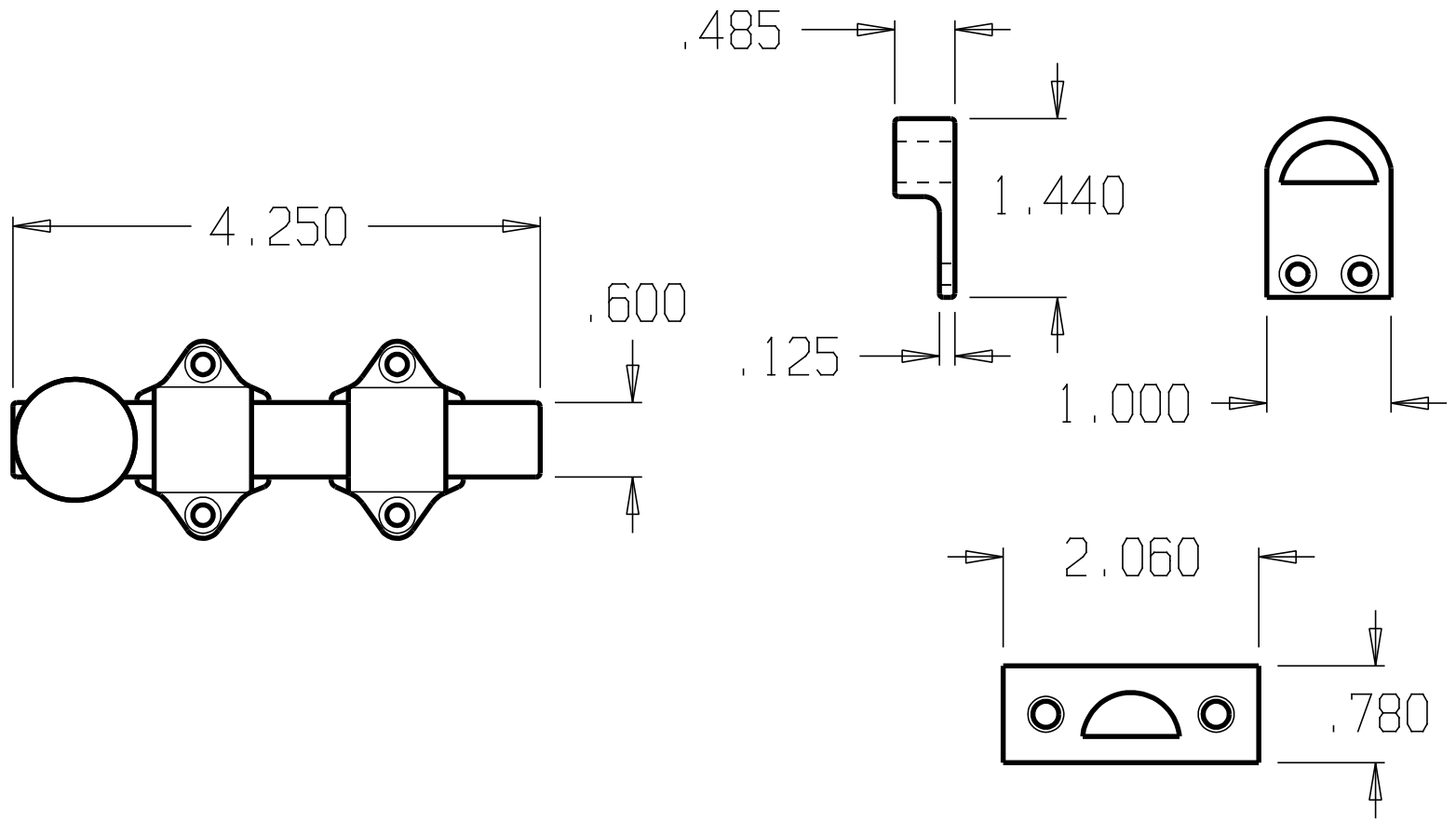

DON-JO MFG. INC.

| | | | | |
|----------|-----------|------------------|-------------------|-------|
| DESIGNER | SIZE A | DATE: 3/29/04 | PART NO. #1630 | REV |
| APPROVED | SCALE | RELEASE DATE | WEIGHT | SHEET |

| REVISIONS | | | | |
|-----------|-----|-------------------------|------|----------|
| ZONE | REV | FINISHES: | DATE | APPROVED |
| | | 605,613,619,620,625,626 | | |

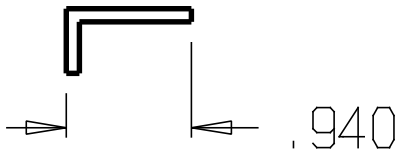
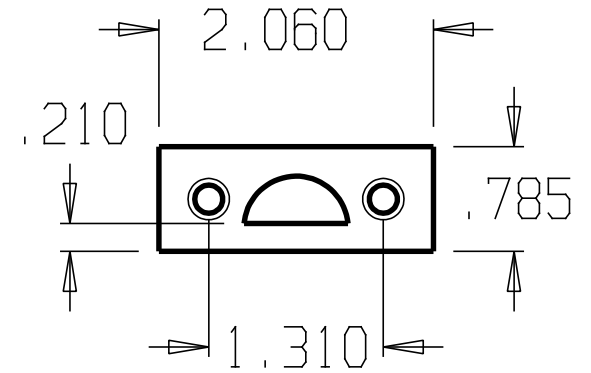
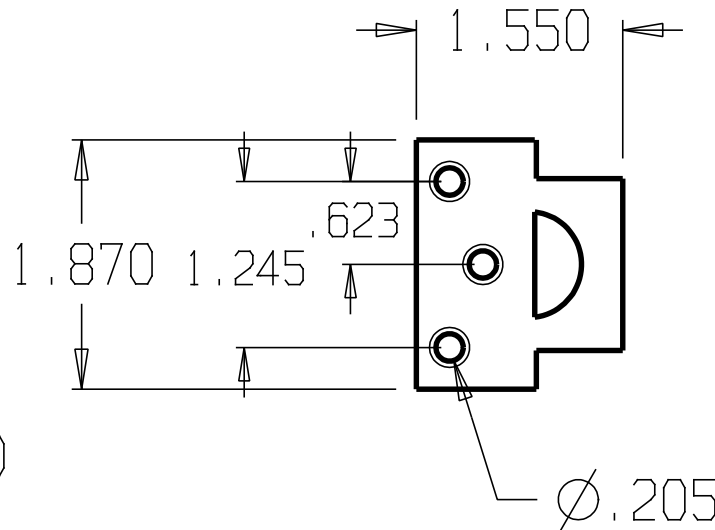
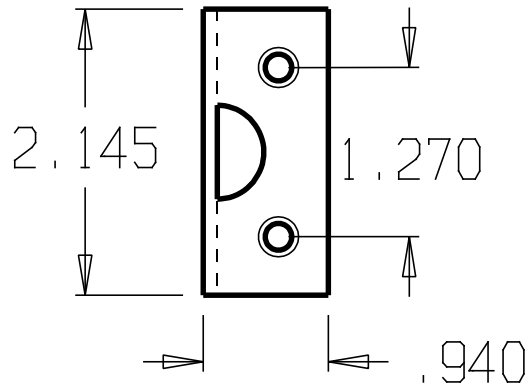
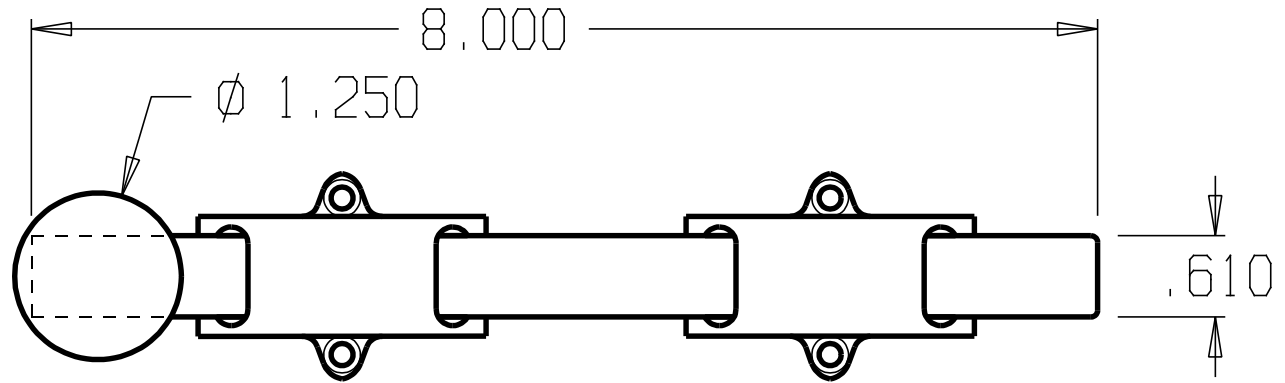
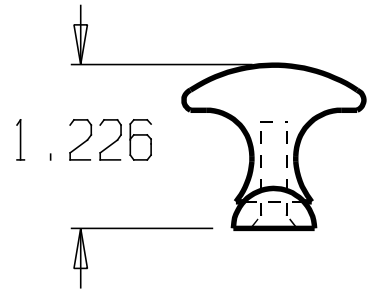

DON-JO MFG. INC.

| | | | | |
|----------|-------|--------------|----------|-------|
| DESIGNER | SIZE | DATE: | PART NO. | REV |
| | A | 3/29/04 | #1632 | |
| APPROVED | SCALE | RELEASE DATE | WEIGHT | SHEET |

| REVISIONS | | | | |
|-----------|-----|-------------------------|------|----------|
| ZONE | REV | FINISHES: | DATE | APPROVED |
| | | 605,613,619,620,625,626 | | |

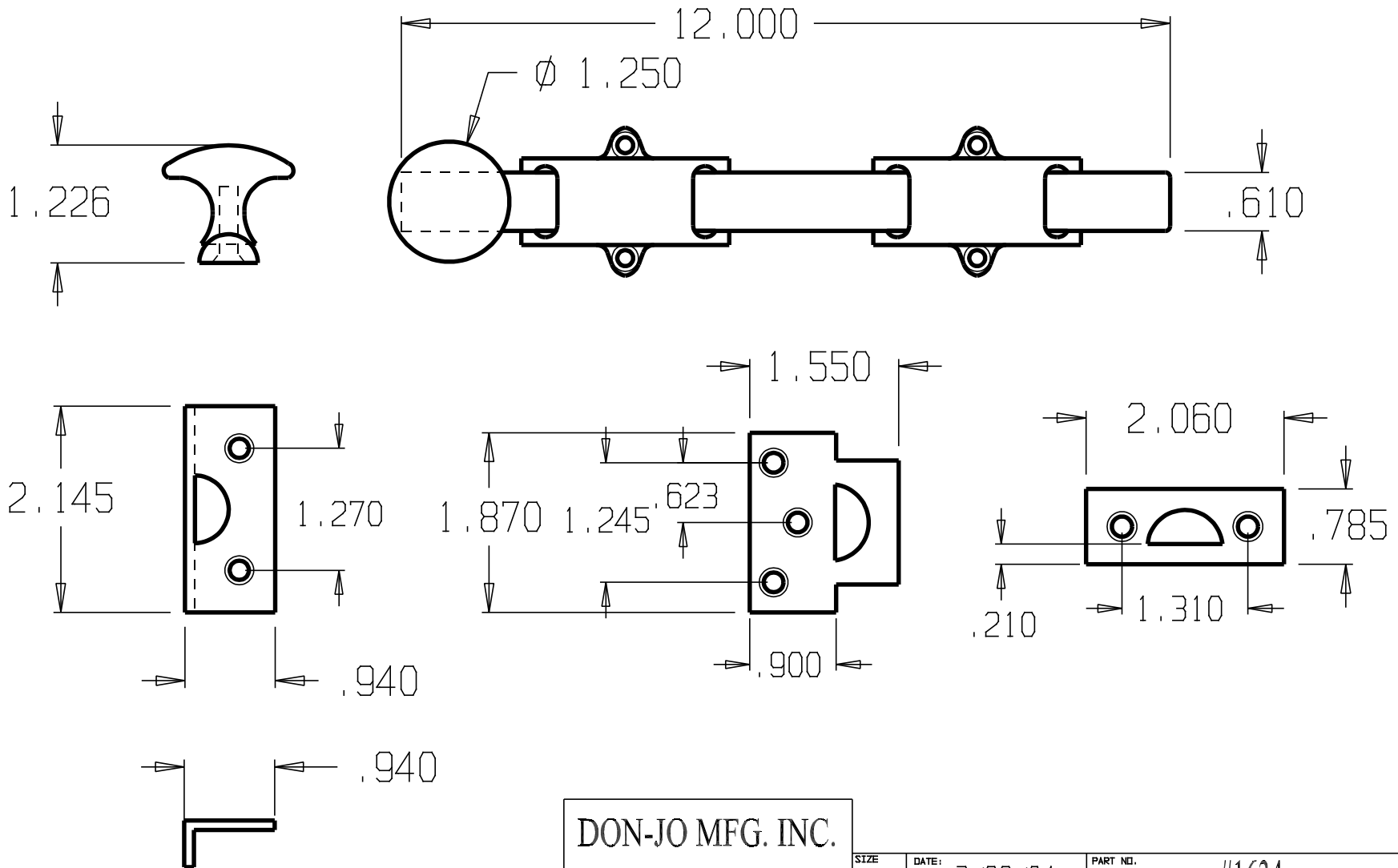

DON-JO MFG. INC.

| | | | | |
|----------|-----------|------------------|-------------------|-------|
| DESIGNER | SIZE A | DATE: 3/29/04 | PART NO. #1634 | REV |
| APPROVED | SCALE | RELEASE DATE | WEIGHT | SHEET |

| REVISIONS | | | | |
|-----------|-----|-------------------------|------|----------|
| ZONE | REV | FINISHES: | DATE | APPROVED |
| | | 605,613,619,620,625,626 | | |

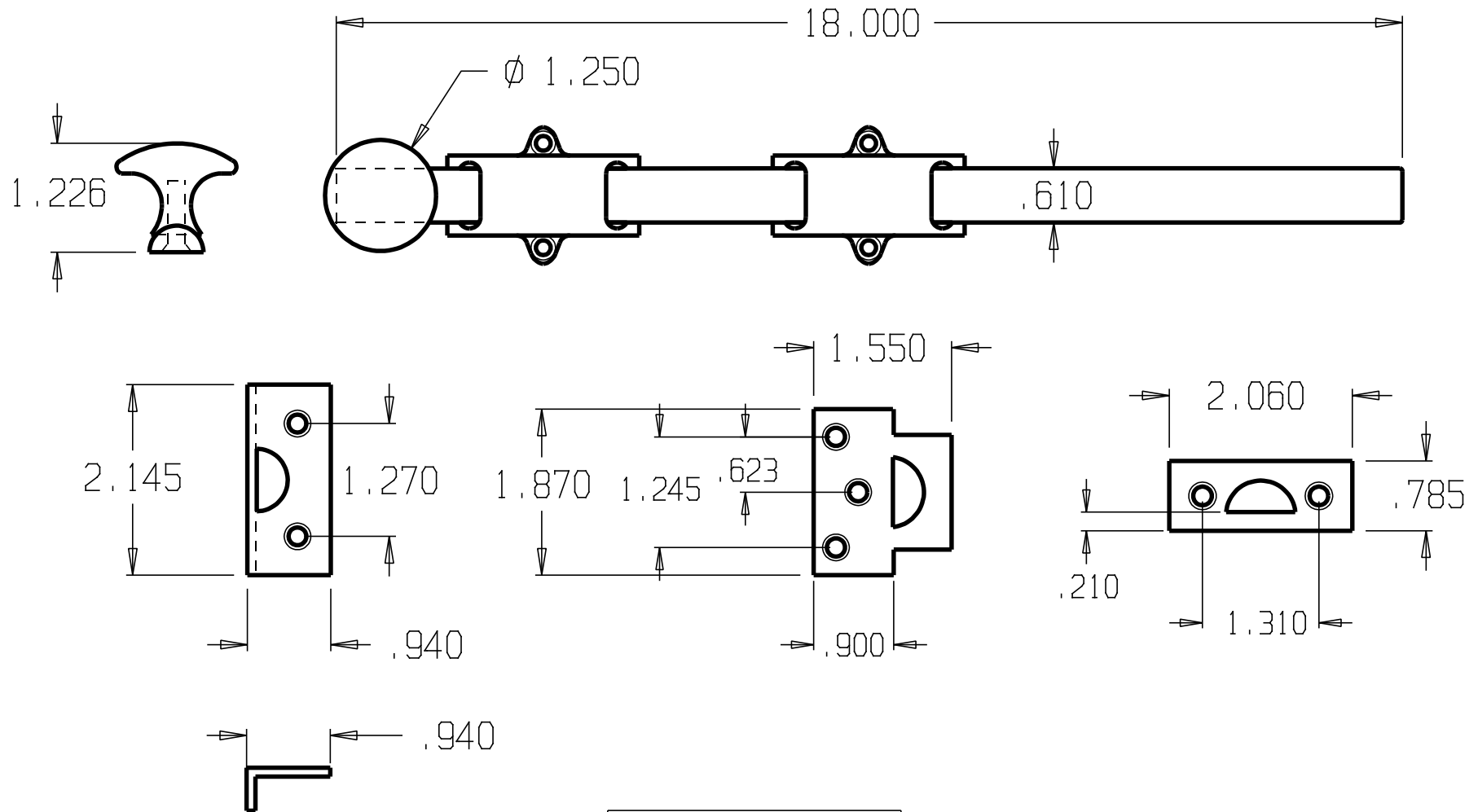

| | | | | | |
|------------------|--|-------|--------------|----------|-------|
| DON-JO MFG. INC. | | SIZE | DATE: | PART NO. | REV |
| | | A | 3/29/04 | #1636 | |
| DESIGNER | | SCALE | RELEASE DATE | WEIGHT | SHEET |
| APPROVED | | | | | |

| REVISIONS | | | | |
|-----------|-----|------------------------------|------|----------|
| ZONE | REV | FINISHES: | DATE | APPROVED |
| | | 605, 613, 619, 620, 625, 626 | | |

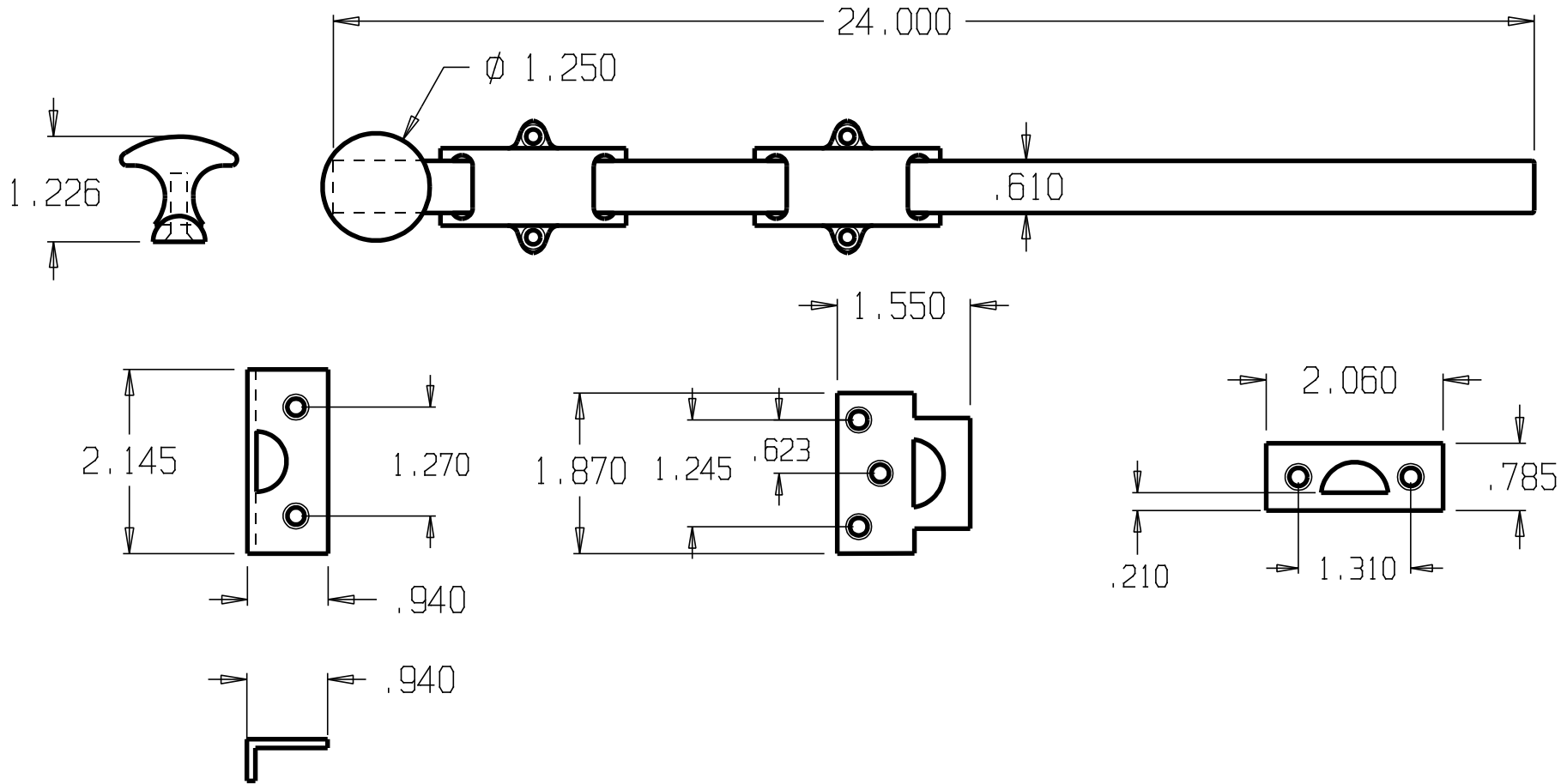

| | | | | | |
|---|--|-----------|------------------|-------------------|-------|
| DON-JO MFG. INC. DESIGNER APPROVED | | SIZE A | DATE: 3/29/04 | PART NO. #1638 | REV |
| | | SCALE | RELEASE DATE | WEIGHT | SHEET |

| REVISIONS | | | | |
|-----------|-----|-------------------------|------|----------|
| ZONE | REV | FINISHES: | DATE | APPROVED |
| | | 605,613,619,620,625,626 | | |

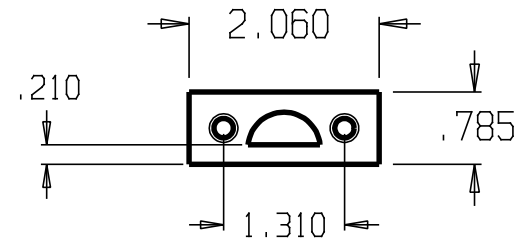
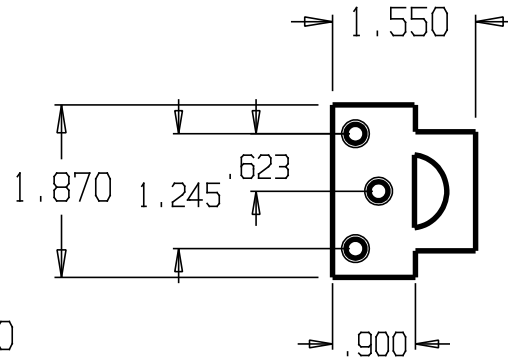
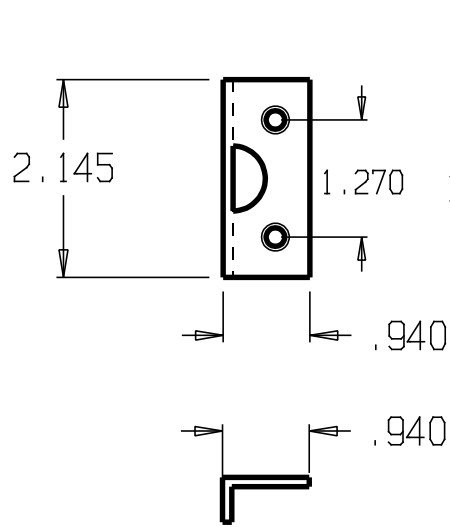
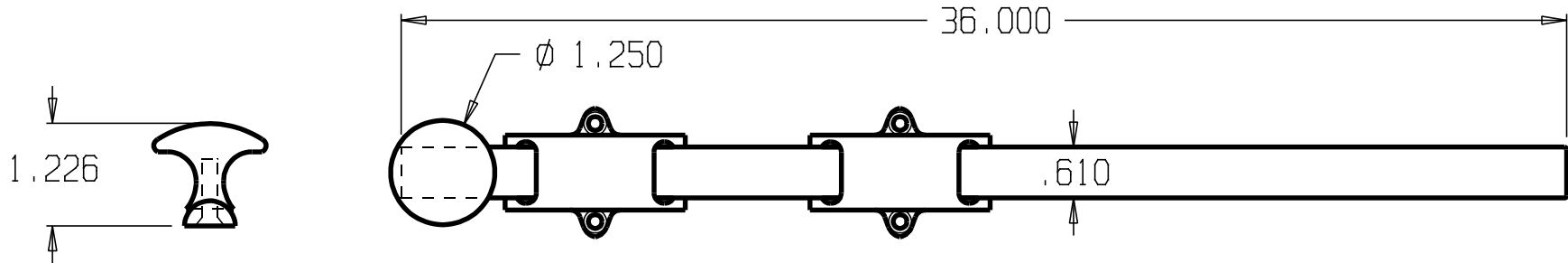

DON-JO MFG. INC.

| | | | | |
|----------|--------------|---------------|----------------|-----|
| DESIGNER | SCALE | DATE: 3/29/04 | PART NO. #1639 | REV |
| APPROVED | RELEASE DATE | WEIGHT | SHEET | |

| REVISIONS | | | | |
|-----------|-----|-------------------------|------|----------|
| ZONE | REV | FINISHES: | DATE | APPROVED |
| | | 605,609,613,619,620,626 | | |

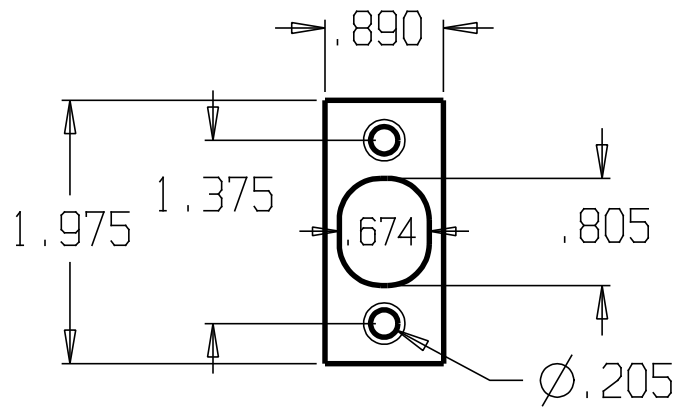
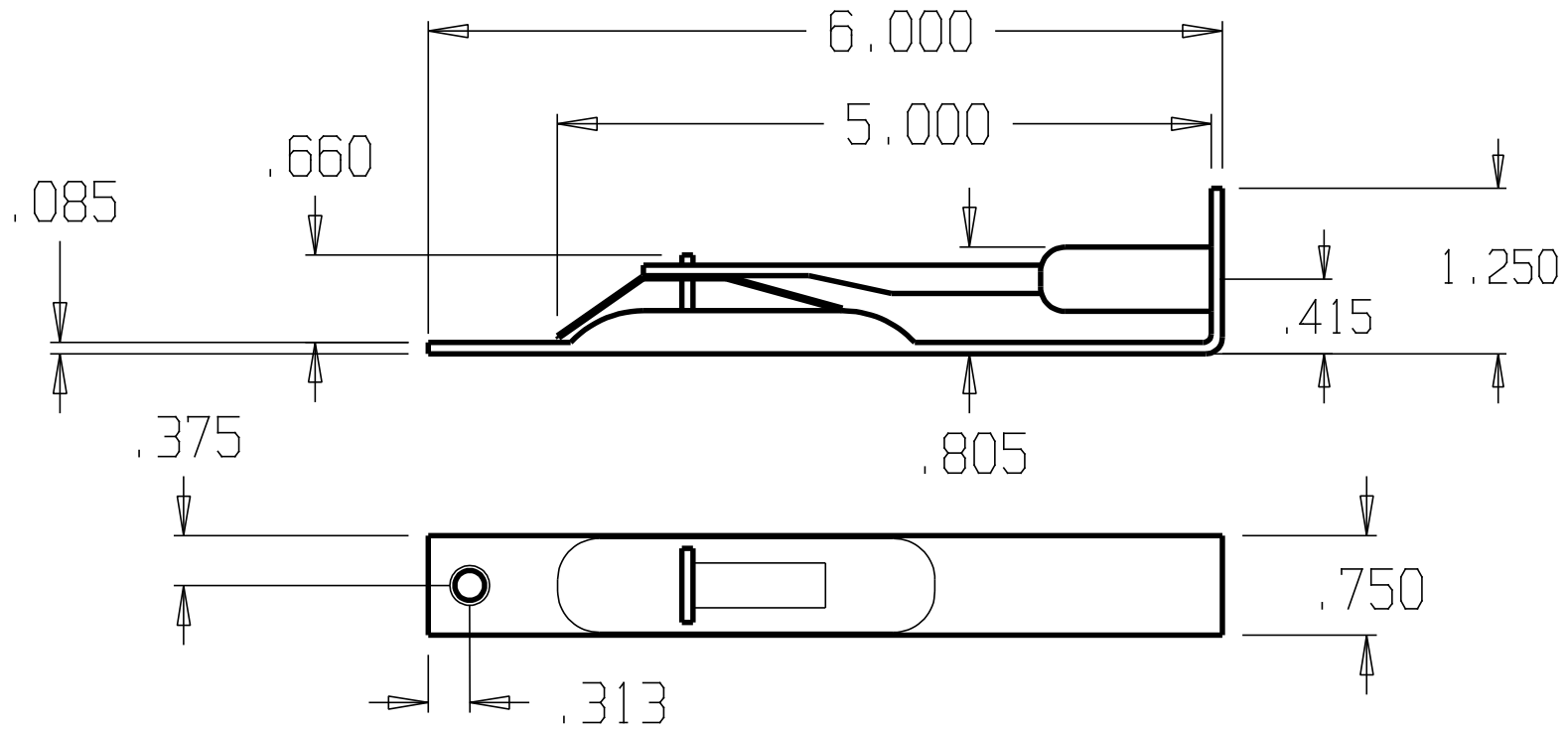

| | | | | | |
|---|--|-----------|------------------|-------------------|-------|
| DON-JO MFG. INC. DESIGNER APPROVED | | SIZE A | DATE: 3/29/04 | PART NO. #1640 | REV |
| | | SCALE | RELEASE DATE | WEIGHT | SHEET |

| REVISIONS | | | | |
|-----------|-----|-------------------------|------|----------|
| ZONE | REV | FINISHES: | DATE | APPROVED |
| | | 605,609,613,619,620,626 | | |

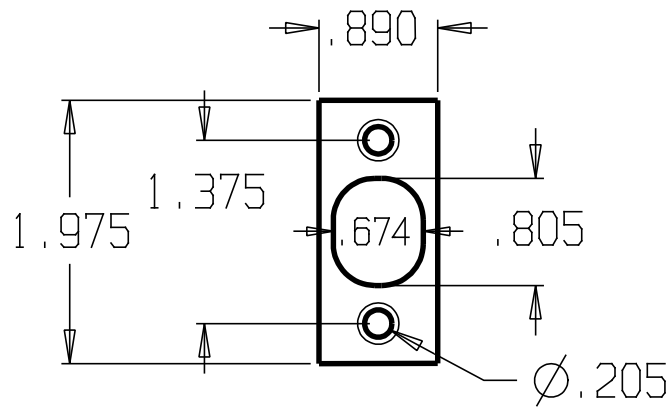
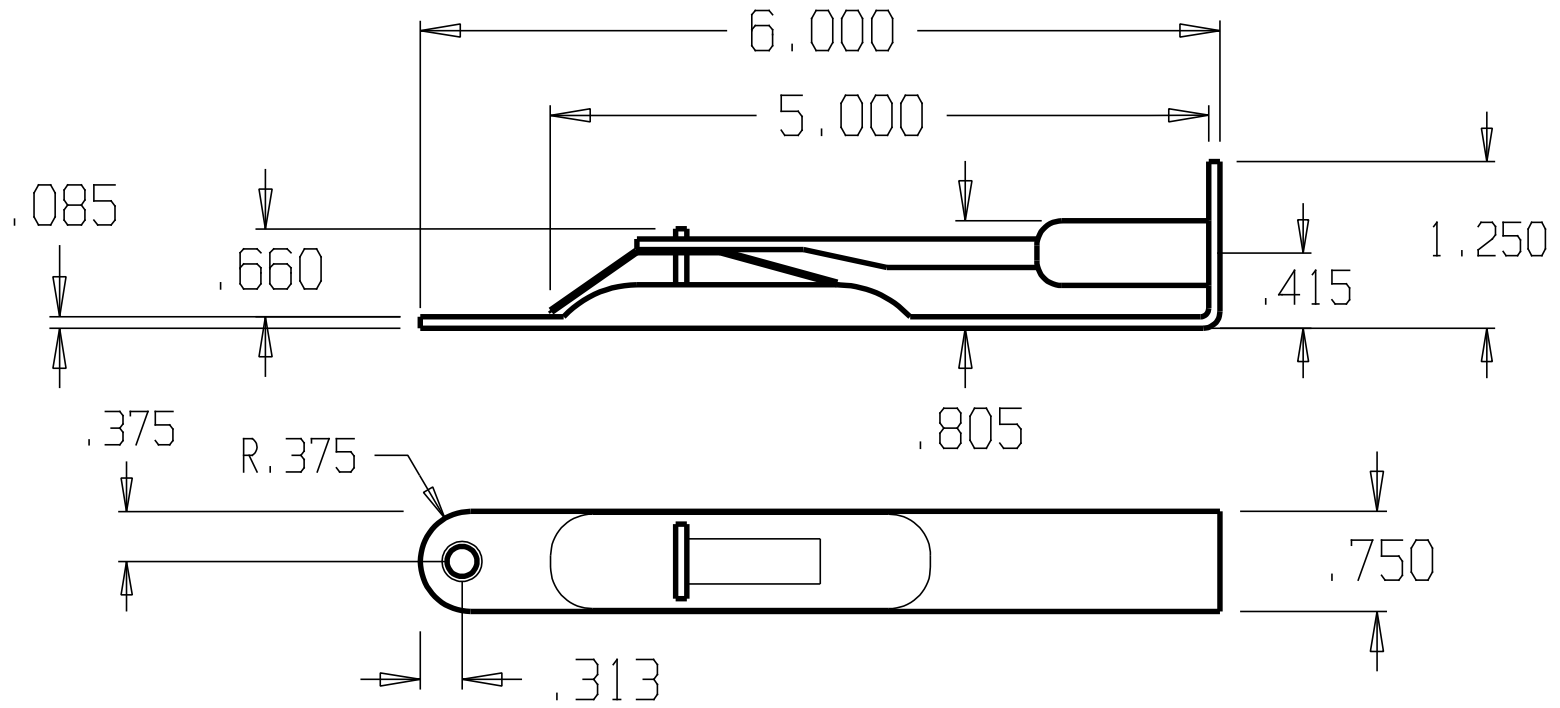

DON-JO MFG. INC.

DESIGNER _____
 APPROVED _____

| | | | |
|-----------|------------------|--------------------|-------|
| SIZE A | DATE: 3/29/04 | PART NO. #1640R | REV |
| SCALE | RELEASE DATE | WEIGHT | SHEET |

| REVISIONS | | | | |
|-----------|-----|---------------------|------|----------|
| ZONE | REV | FINISHES: | DATE | APPROVED |
| | | 605,613,619,620,626 | | |

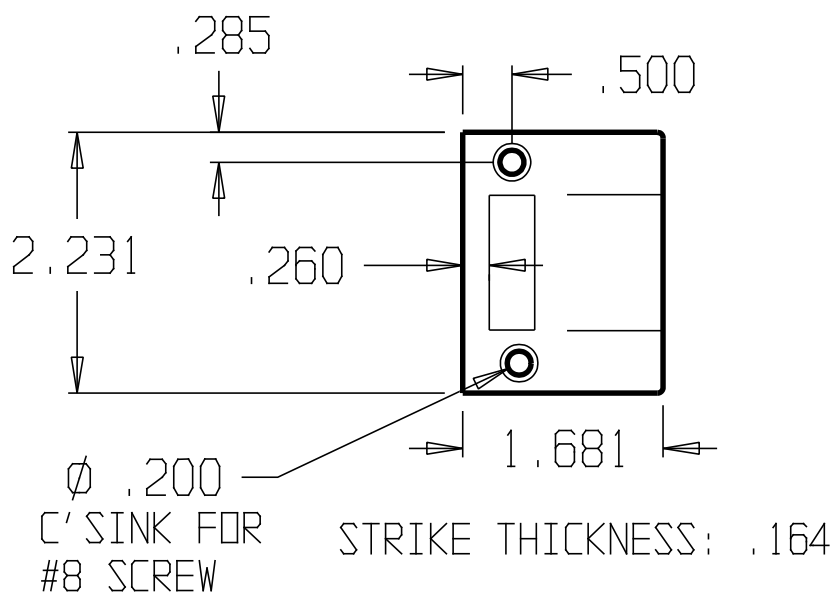
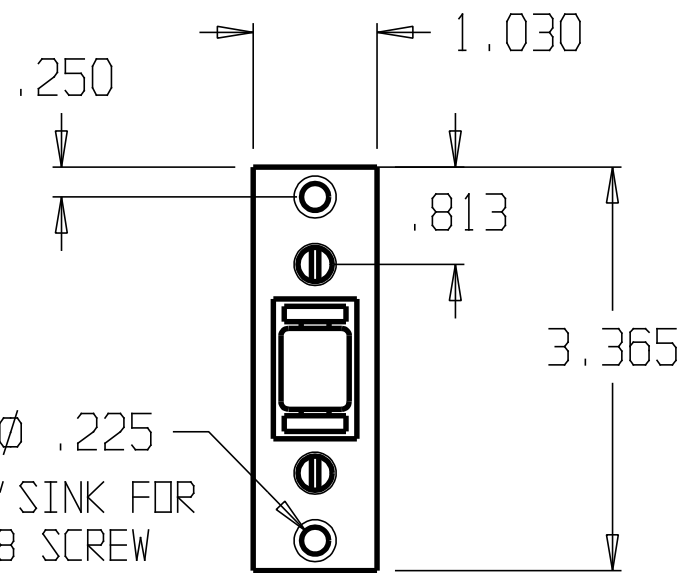
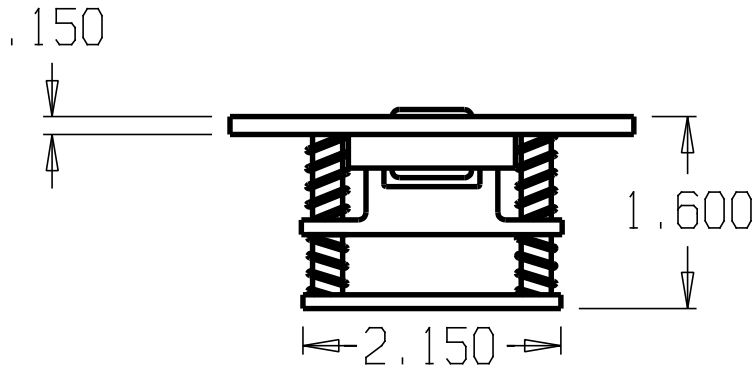

Pocket in door needed
 15/16" Wide x 2 1/4" Long x 1 1/2" Deep

| | | | | | |
|------------------|--|-------|--------------|----------|-------|
| DON-JO MFG. INC. | | SIZE | DATE: | PART NO. | REV |
| DESIGNER | | A | 8/18/06 | #1700 | |
| APPROVED | | SCALE | RELEASE DATE | WEIGHT | SHEET |

| REVISIONS | | | |
|-----------|-----|-------------------------|----------|
| ZONE | REV | FINISHES: | DATE |
| | | 605, 613, 619, 620, 626 | |
| | | | APPROVED |

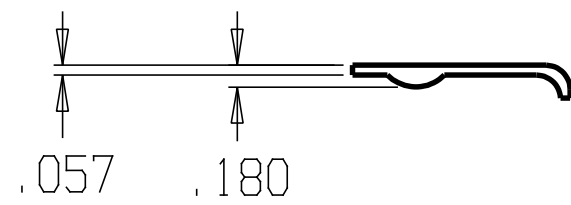
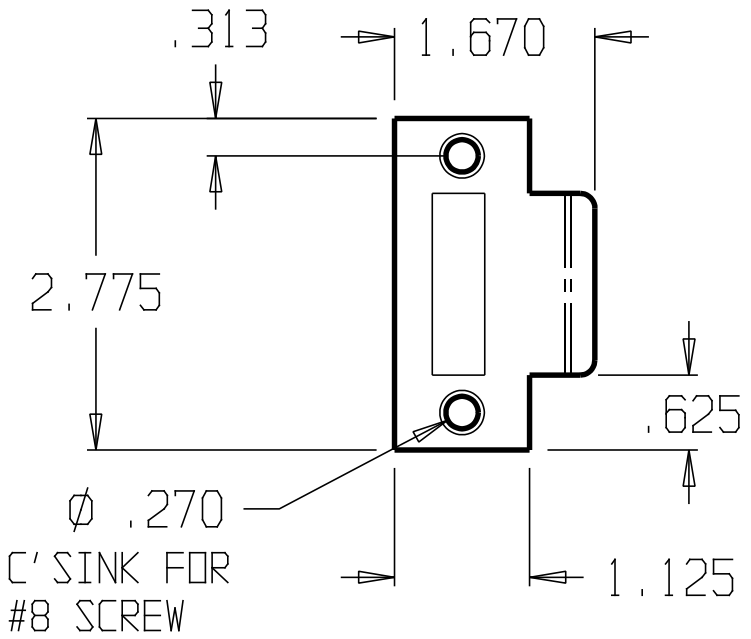
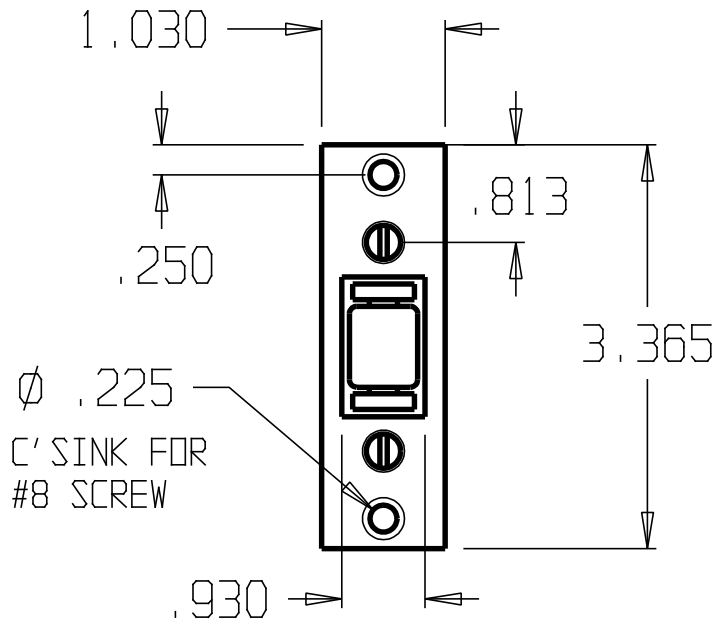
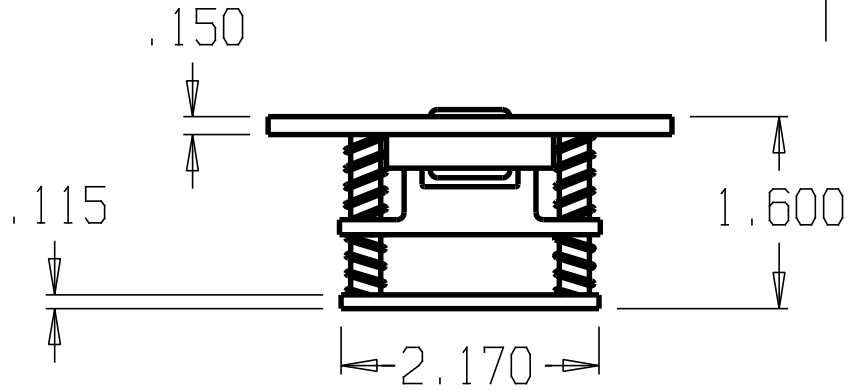

MORTISE .930" X 2.2" X 1.6"
FOR MECHANISM

DON-JO MFG. INC.

| | | | | |
|----------|-------|--------------|----------|-------|
| DESIGNER | SIZE | DATE: | PART NO. | REV |
| | A | 8/17/06 | #1702 | |
| APPROVED | SCALE | RELEASE DATE | WEIGHT | SHEET |

| REVISIONS | | | | |
|-----------|-----|-------------------------|------|----------|
| ZONE | REV | FINISHES: | DATE | APPROVED |
| | | 605, 613, 619, 620, 626 | | |

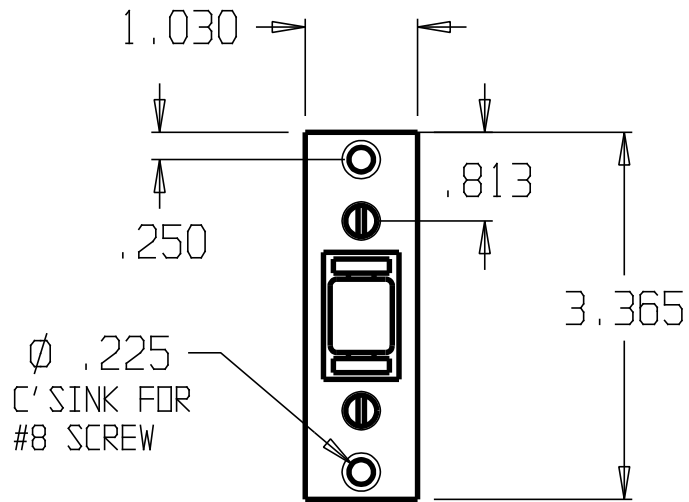
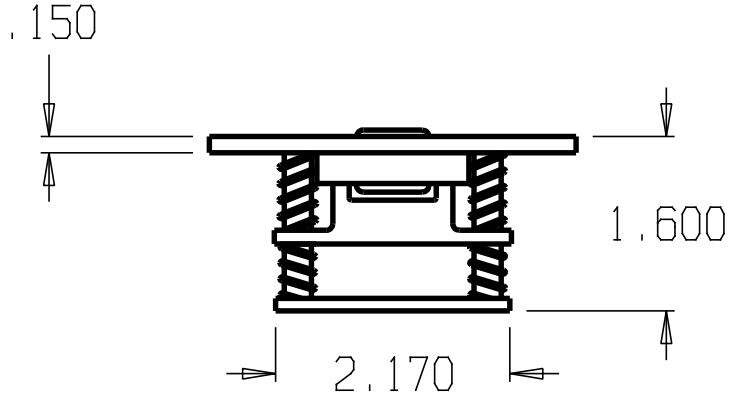

MORTISE .930" X 2.2" X 1.6"
FOR MECHANISM

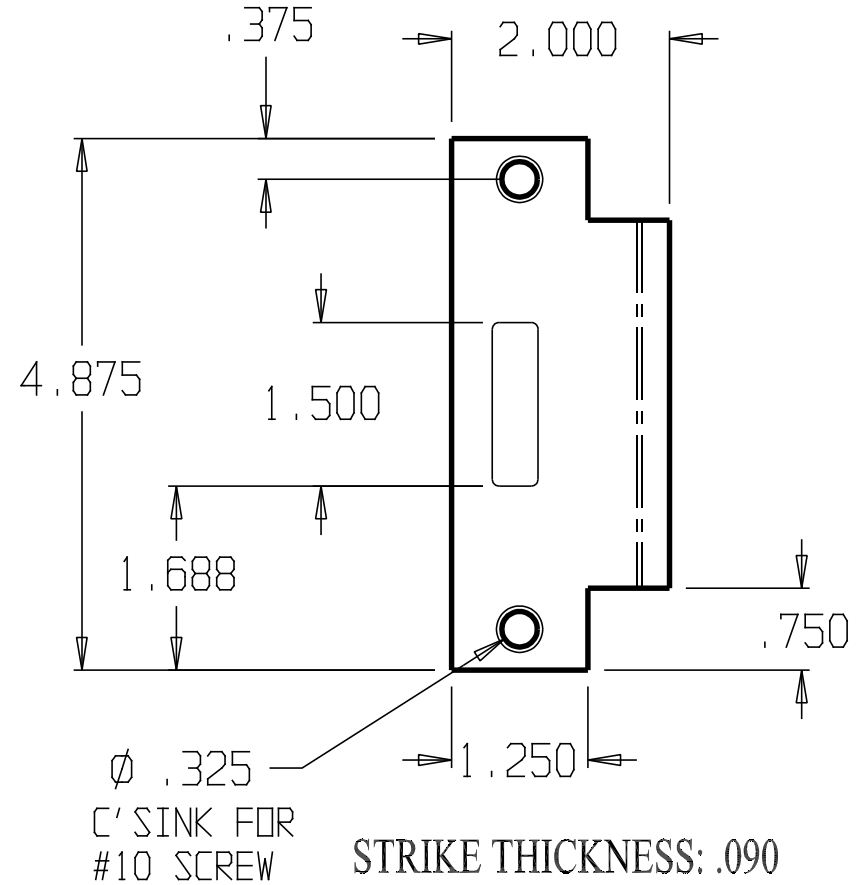

DON-JO MFG. INC.

| | | | | |
|----------|--------------|---------------|----------------|-----|
| DESIGNER | SCALE | DATE: 3/29/04 | PART NO. #1704 | REV |
| APPROVED | RELEASE DATE | WEIGHT | SHEET | |

| REVISIONS | | |
|-----------|-----|-------------------------|
| ZONE | REV | FINISHES: |
| | | 605, 613, 619, 620, 626 |
| | | GAUGE: |

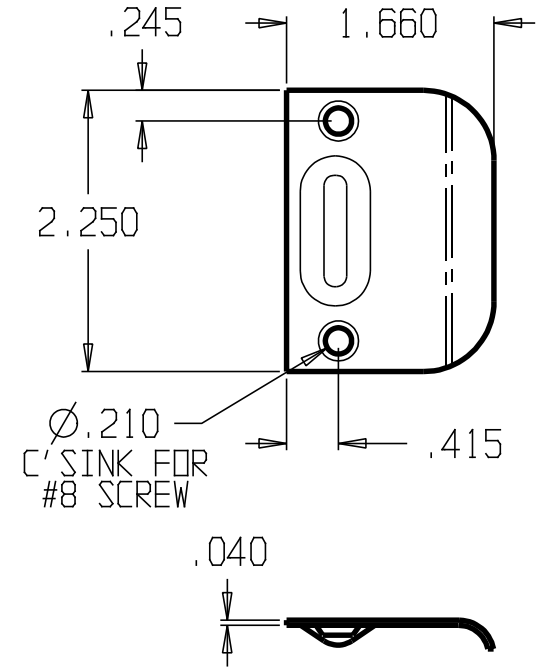
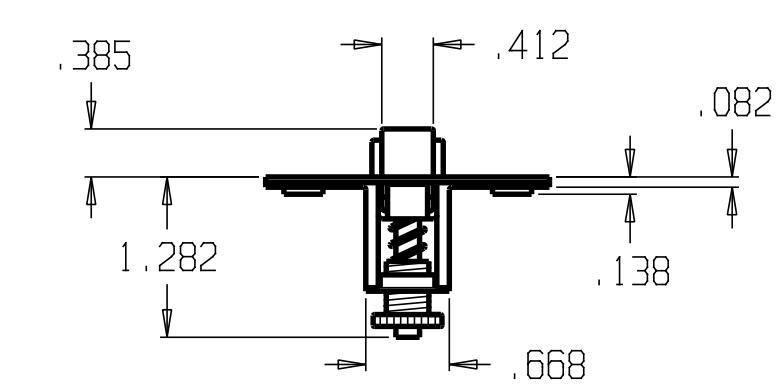

Ø.210
C' SINK FOR
#8 SCREW

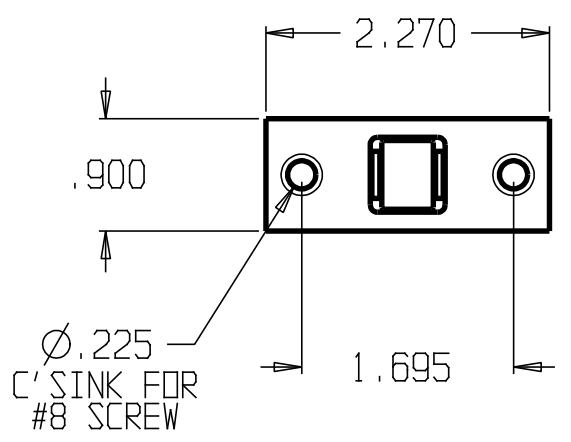

Ø.225
C' SINK FOR
#8 SCREW

| | | | | | |
|------------------|--|-------|--------------|----------|-------|
| DON-JO MFG. INC. | | SIZE | DATE: | PART NO. | REV |
| DESIGNER | | A | 12/15/04 | #1710 | |
| APPROVED | | SCALE | RELEASE DATE | WEIGHT | SHEET |

| REVISIONS | | | | |
|-----------|-----|-------------------------|------|----------|
| ZONE | REV | FINISHES: | DATE | APPROVED |
| | | 605, 613, 619, 620, 626 | | |

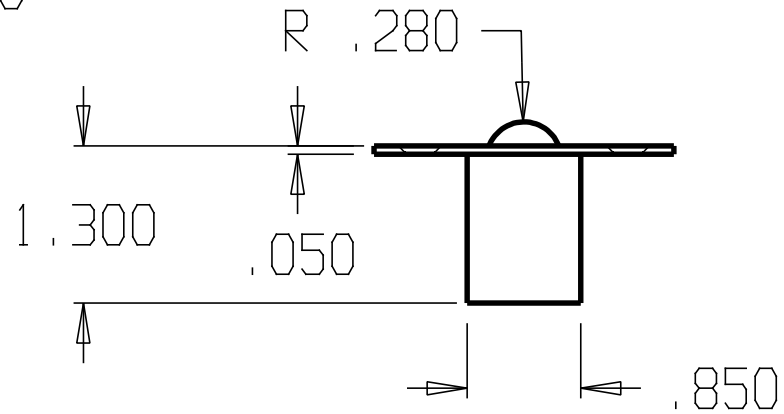
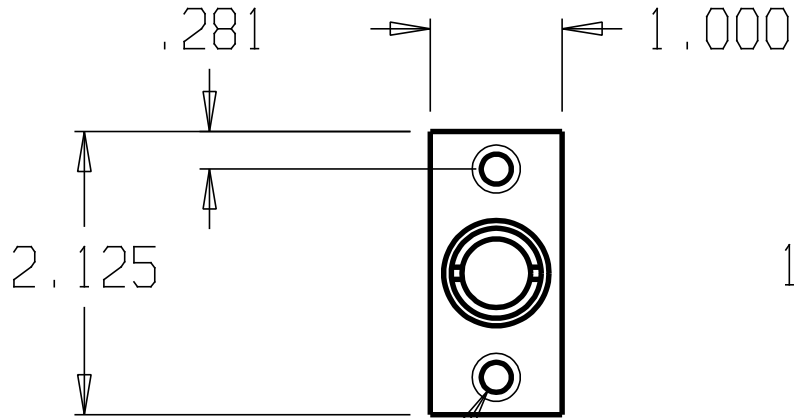

Ø .225
C' SINK FOR
#8 SCREW

STRIKE THICKNESS: .050

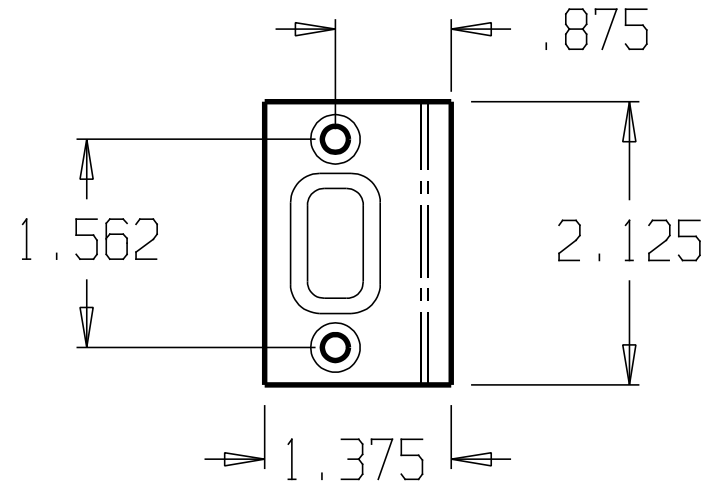
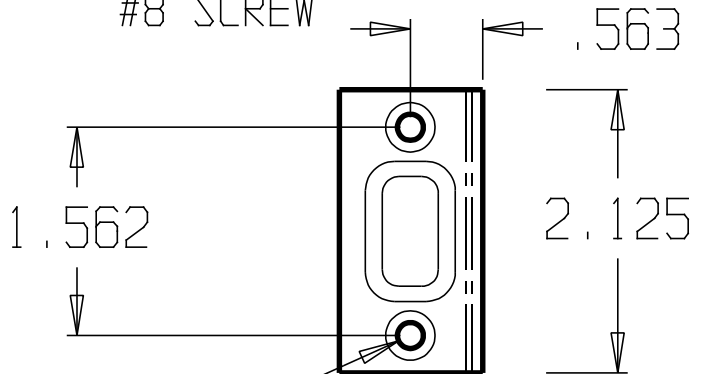

Ø .195
C' SINK FOR
#6 x 1/2"
WOOD SCREW

DON-JO MFG. INC.

DESIGNER
APPROVED

SIZE: A
DATE: 3/29/04
SCALE: RELEASE DATE: WEIGHT: SHEET:

PART NO. #1712
REV

| REVISIONS | | | | |
|-----------|-----|-----------|------|----------|
| ZONE | REV | FINISHES: | DATE | APPROVED |
| | | 605, 609 | | |

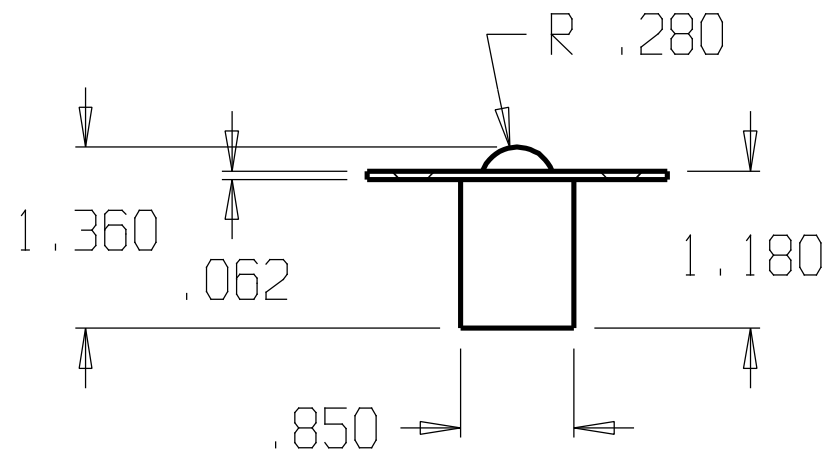
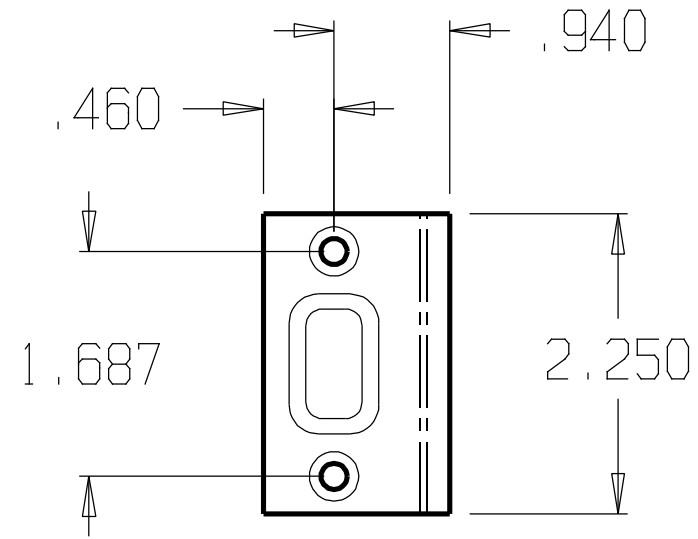
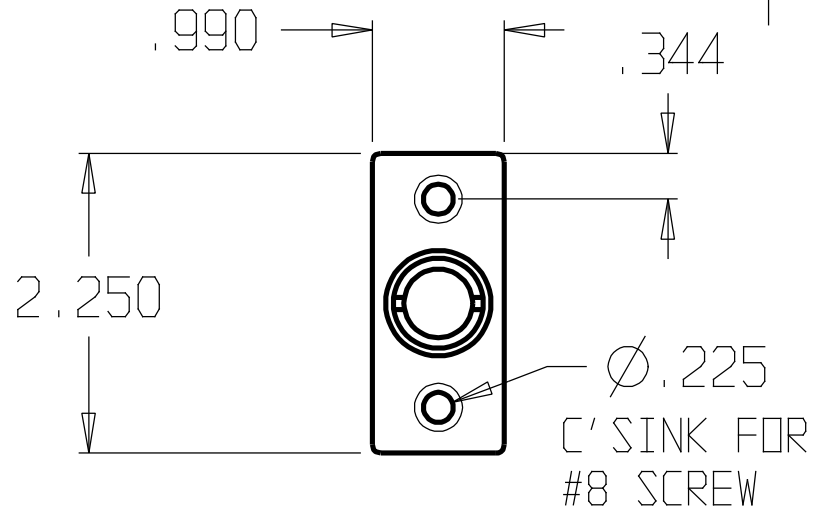

| | | | | | |
|------------------|----------|-------|--------------|----------|-------|
| DON-JO MFG. INC. | | SIZE | DATE: | PART NO. | REV |
| | | A | 10/6/11 | #1714 | |
| DESIGNER | APPROVED | SCALE | RELEASE DATE | WEIGHT | SHEET |

| REVISIONS | | | | |
|-----------|-----|------------------------------|------|----------|
| ZONE | REV | FINISHES: | DATE | APPROVED |
| | | 605, 609, 613, 619, 620, 626 | | |

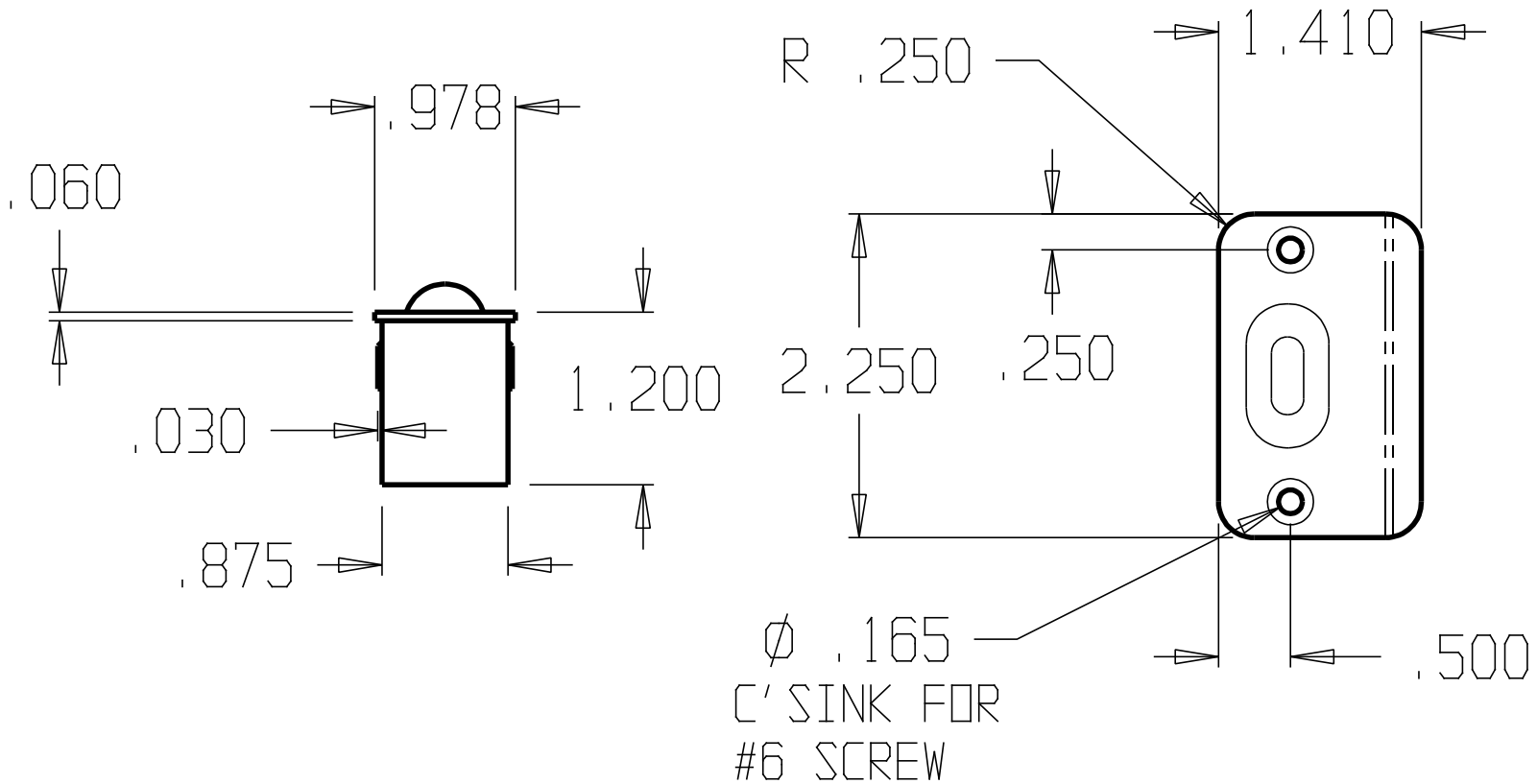

STRIKE THICKNESS: .050

DON-JO MFG. INC.

| | | | | |
|----------|-----------|------------------|-------------------|-------|
| DESIGNER | SIZE A | DATE: 3/29/04 | PART NO. #1716 | REV |
| APPROVED | SCALE | RELEASE DATE | WEIGHT | SHEET |

| REVISIONS | | | |
|-----------|-----|-----------------------------------|------|
| ZONE | REV | FINISHES: | DATE |
| | | 605, 609, 613, 619, 620, 625, 626 | |
| | | APPROVED | |

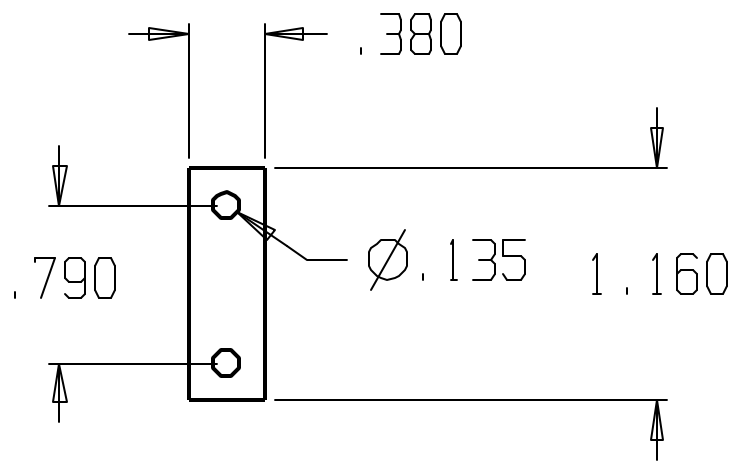
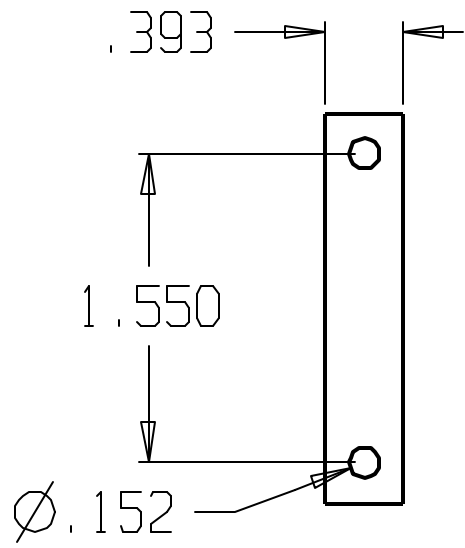
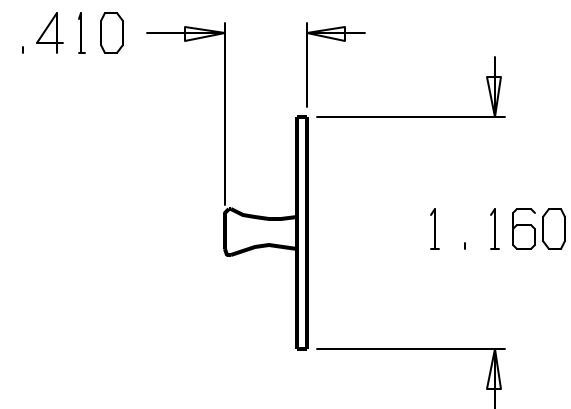
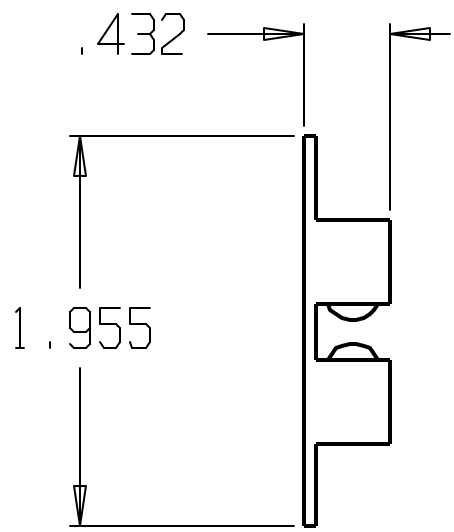

| | | | | | |
|---|--|-------|--------------|----------|-------|
| DON-JO MFG. INC. DESIGNER APPROVED | | SIZE | DATE | PART NO. | REV |
| | | A | 4/1/04 | #1718 | |
| | | SCALE | RELEASE DATE | WEIGHT | SHEET |

| REVISIONS | | | | |
|-----------|-----|-----------|------|----------|
| ZONE | REV | FINISHES: | DATE | APPROVED |
| | | 605, 626 | | |

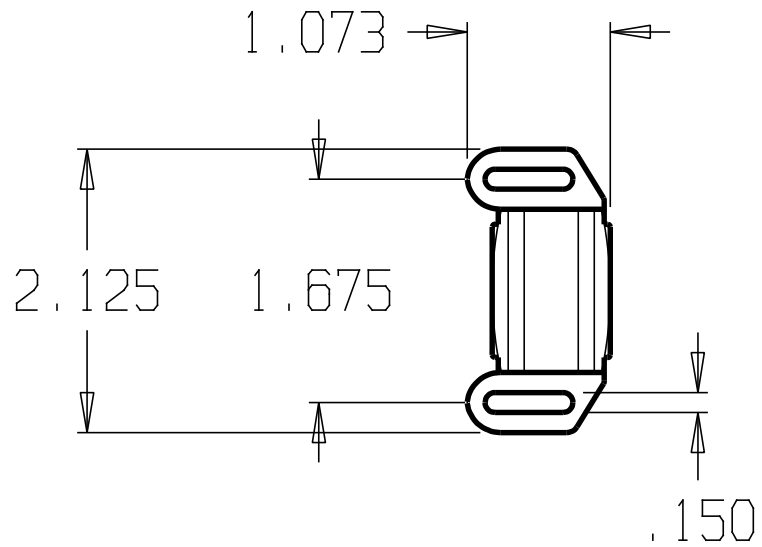
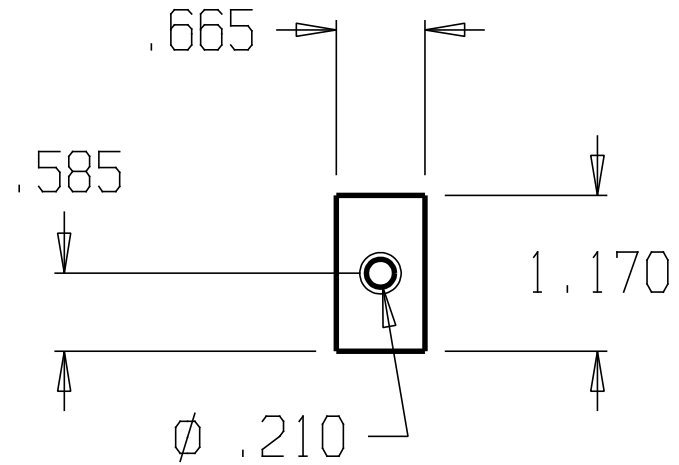
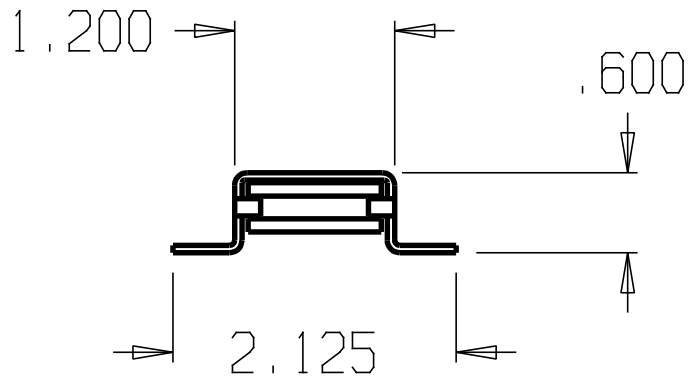

DON-JO MFG. INC.

DESIGNER
APPROVED

SIZE: A
SCALE

DATE: 3/31/04

PART NO. #1720

REV

RELEASE DATE

WEIGHT

SHEET

| REVISIONS | | | | |
|-----------|-----|-----------|------|----------|
| ZONE | REV | FINISHES: | DATE | APPROVED |
| | | 605,626 | | |

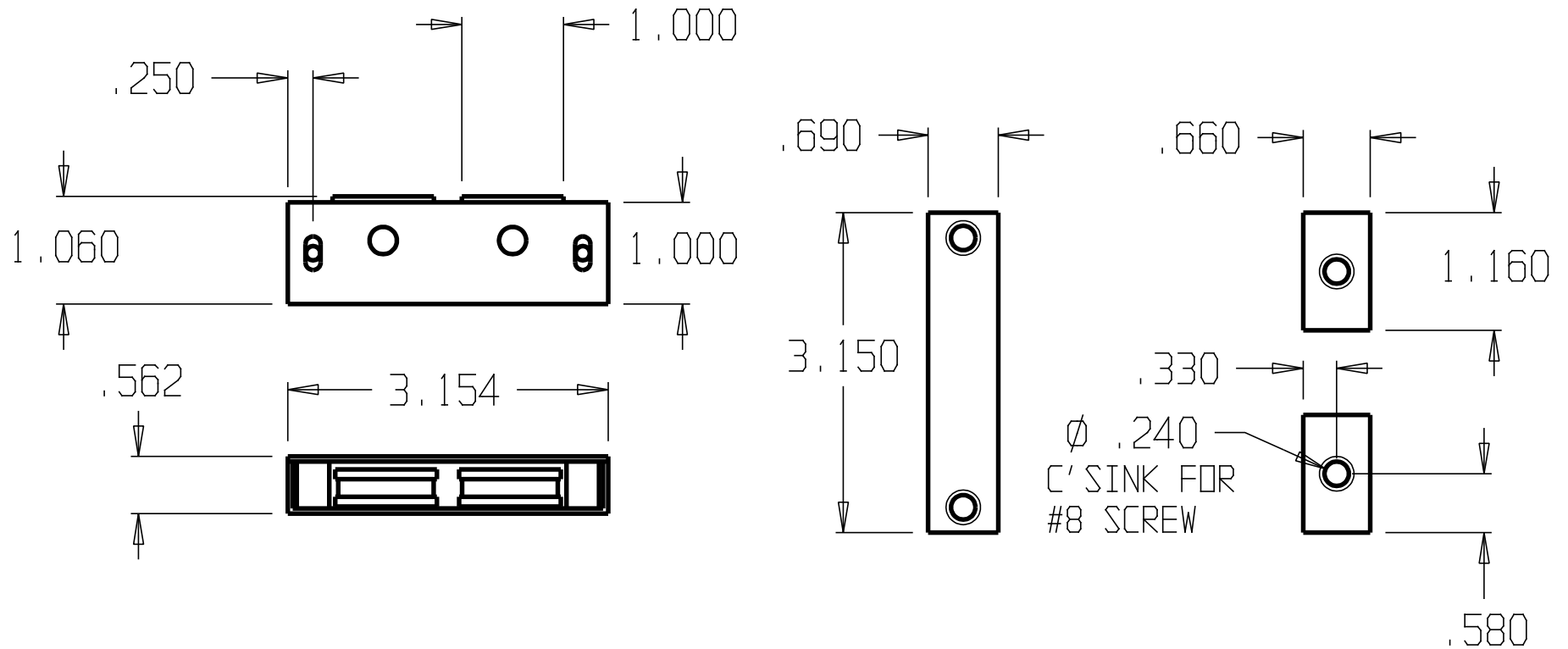

DON-JO MFG. INC.

| | | | | |
|----------|-------|--------------|----------|-------|
| DESIGNER | SIZE | DATE: | PART NO. | REV |
| | A | 4/1/04 | #1722 | |
| APPROVED | SCALE | RELEASE DATE | WEIGHT | SHEET |
| | | | | |

| REVISIONS | | | | |
|-----------|-----|-----------|------|----------|
| ZONE | REV | FINISHES: | DATE | APPROVED |
| | | 605,626 | | |

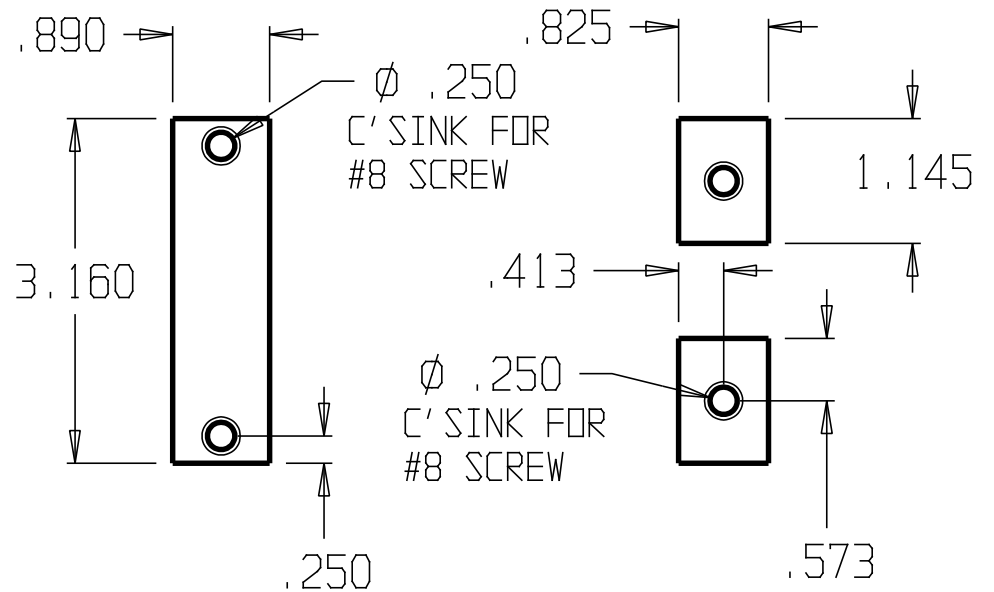
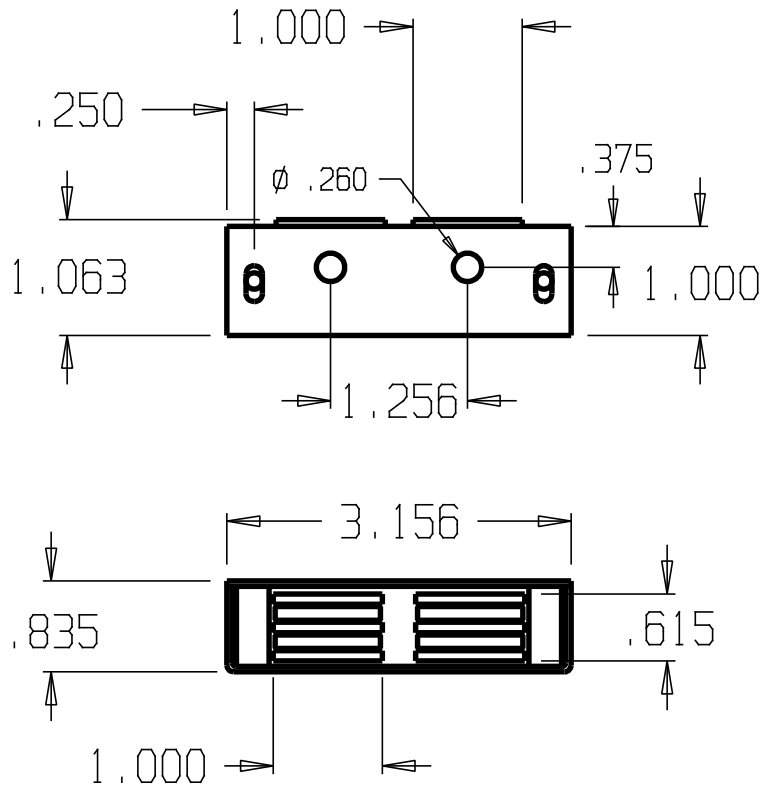

DON-JO MFG. INC.

| | | | | |
|----------|-----------|-----------------|-------------------|-------|
| DESIGNER | SIZE A | DATE: 4/1/04 | PART NO. #1724 | REV |
| APPROVED | SCALE | RELEASE DATE | WEIGHT | SHEET |

| REVISIONS | | | | |
|-----------|-----|-------------------------|------|----------|
| ZONE | REV | FINISHES: | DATE | APPROVED |
| | | 605, 613, 619, 620, 626 | | |

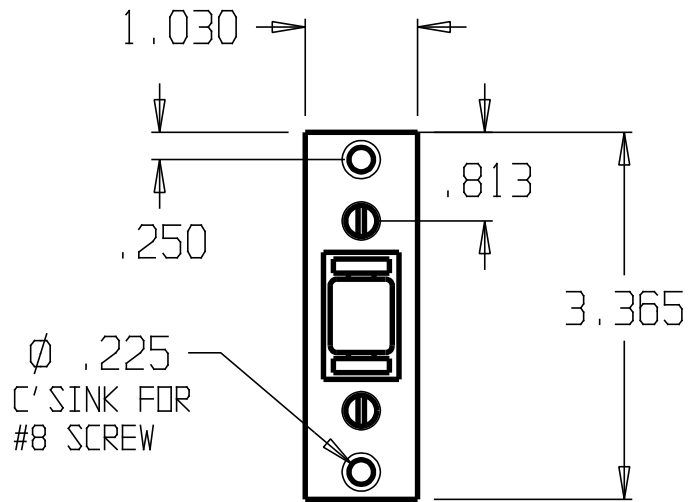
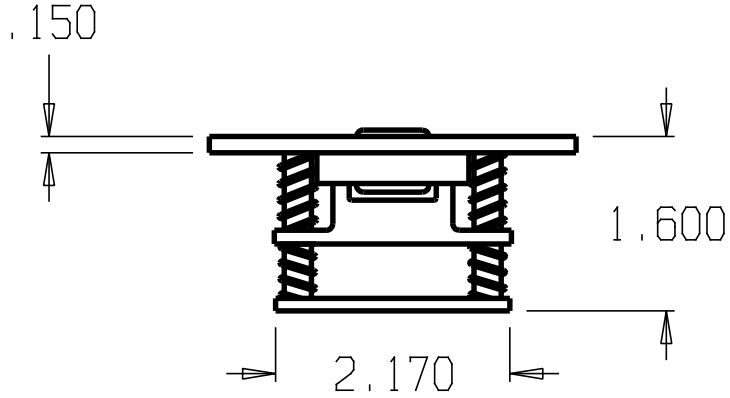

MORTISE .930" X 2.2" X 1.6"
FOR MECHANISM

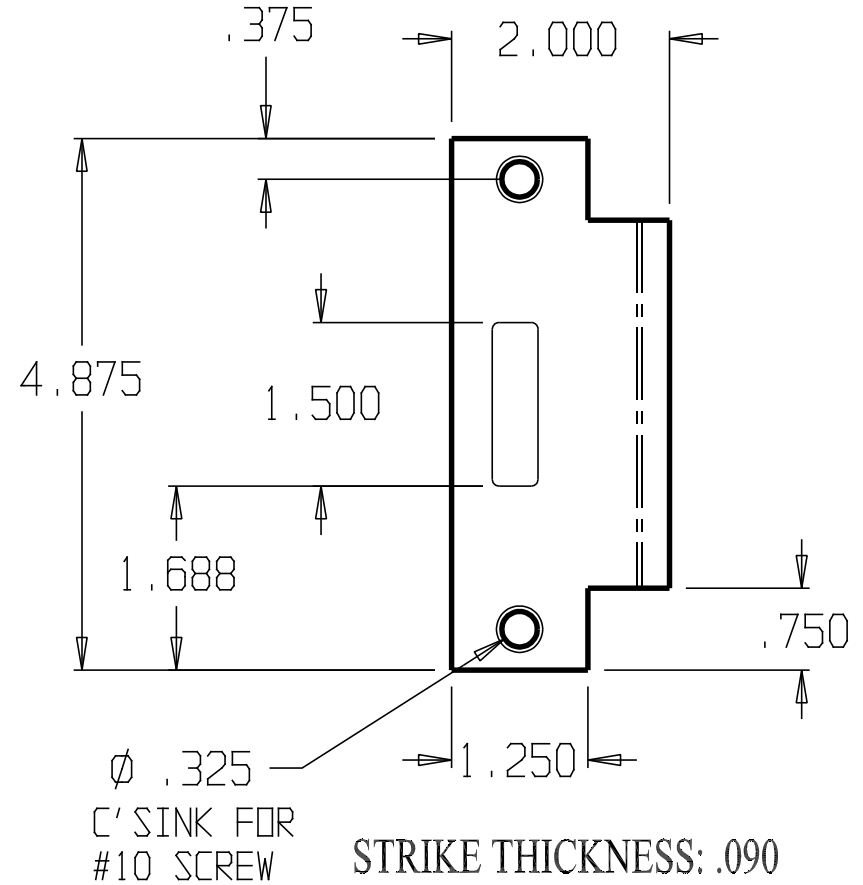

STRIKE THICKNESS: .090

DON-JO MFG. INC.

| | | | |
|----------|---------------|----------------|--------|
| DESIGNER | DATE: 3/29/04 | PART NO. #1704 | REV |
| APPROVED | SCALE | RELEASE DATE | WEIGHT |
| | | | SHEET |

| REVISIONS | | |
|-----------|-----|------------------------------|
| ZONE | REV | FINISHES : |
| | | 605, 613, 609, 620, 625, 626 |
| | | GAUGE : |

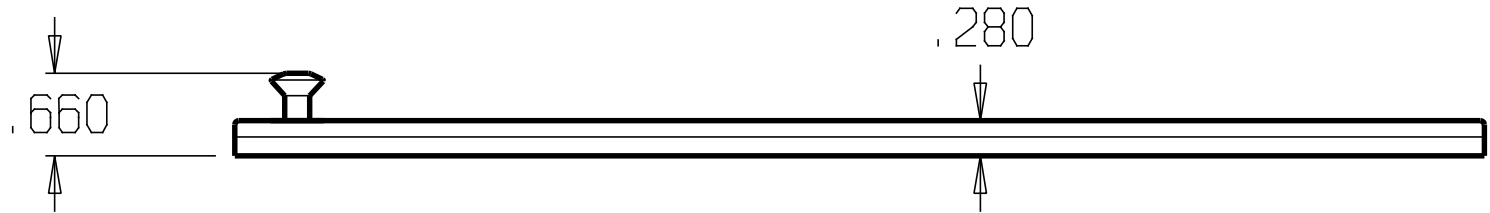
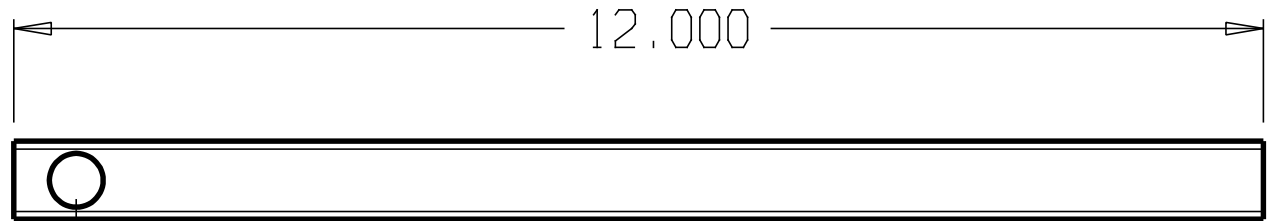

DON-JO MFG. INC.

| | | | | |
|----------|-------|--------------|----------|-------|
| DESIGNER | SIZE | DATE: | PART NO. | REV |
| | A | 6/3/04 | SB-12 | |
| APPROVED | SCALE | RELEASE DATE | WEIGHT | SHEET |

REVISIONS

| | | | |
|------|-----|-------------------------|--------|
| ZONE | REV | FINISHES: | GAUGE: |
| | | 605, 613, 609, 625, 626 | |

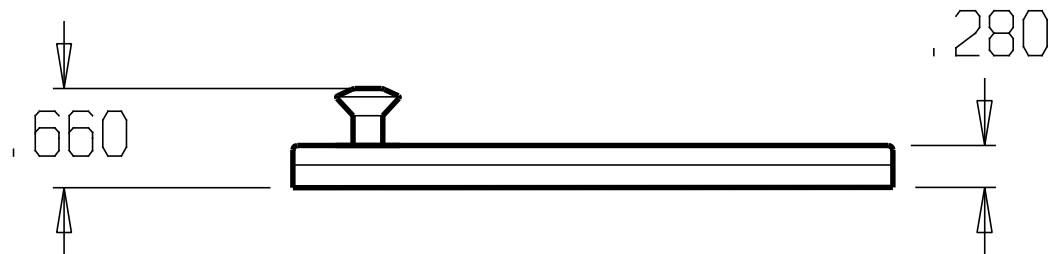
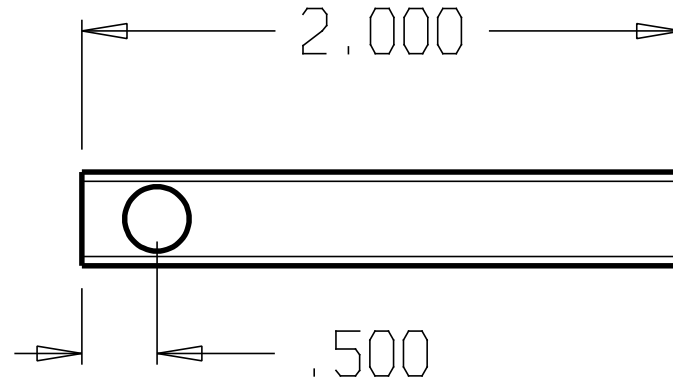

DON-JO MFG. INC.

| | | | | |
|----------|-------|--------------|----------|-------|
| DESIGNER | SIZE | DATE: | PART NO. | REV |
| | A | 6/3/04 | SB-2 | |
| APPROVED | SCALE | RELEASE DATE | WEIGHT | SHEET |
| | | | | |

REVISIONS

| | | | |
|------|-----|-------------------------|--------|
| ZONE | REV | FINISHES: | GUAGE: |
| | | 605, 613, 609, 625, 626 | |

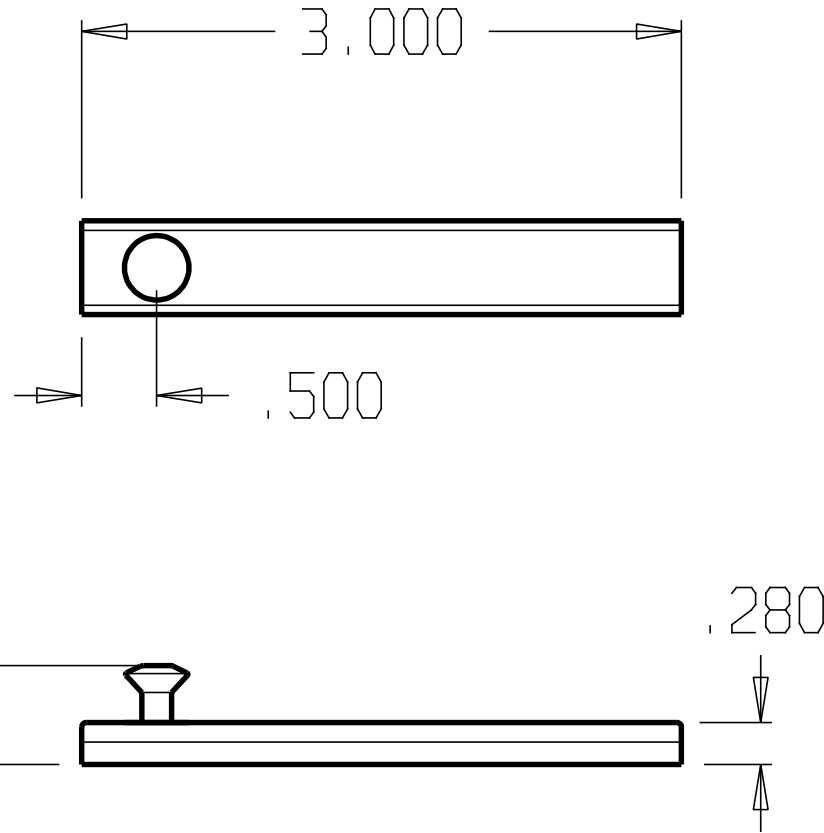

DON-JO MFG. INC.

| | | | | |
|----------|-------|--------------|----------|-------|
| DESIGNER | SIZE | DATE: | PART NO. | REV |
| | A | 6/3/04 | SB-3 | |
| APPROVED | SCALE | RELEASE DATE | WEIGHT | SHEET |
| | | | | |

| REVISIONS | | |
|-----------|-----|--|
| ZONE | REV | FINISHES: 605, 613, 609, 619, 620, 625, 626 |
| | | GAUGE: |

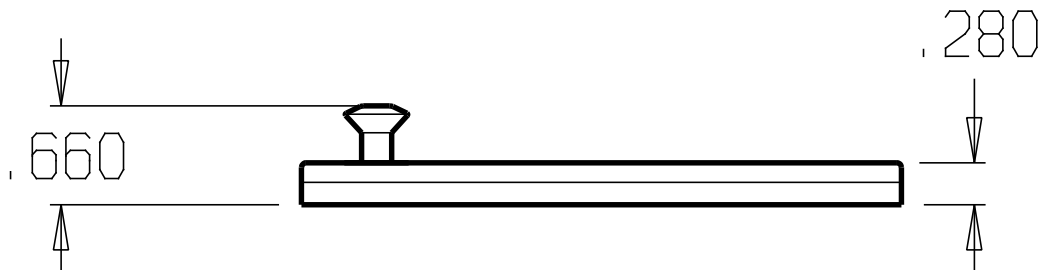
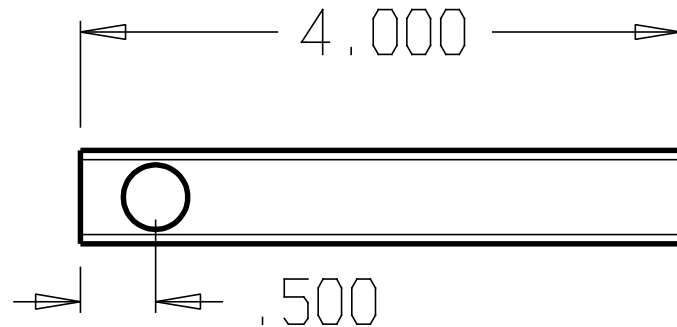

DON-JO MFG. INC.

| | | | | |
|----------|-----------|--------------|------------------|-------|
| DESIGNER | SIZE A | DATE: | PART NO. SB-4 | REV |
| APPROVED | SCALE | RELEASE DATE | WEIGHT | SHEET |

| REVISIONS | | |
|-----------|-----|---|
| ZONE | REV | FINISHES: 605, 613, 609, 619, 620, 625, 626 |
| | | GAUGE: |

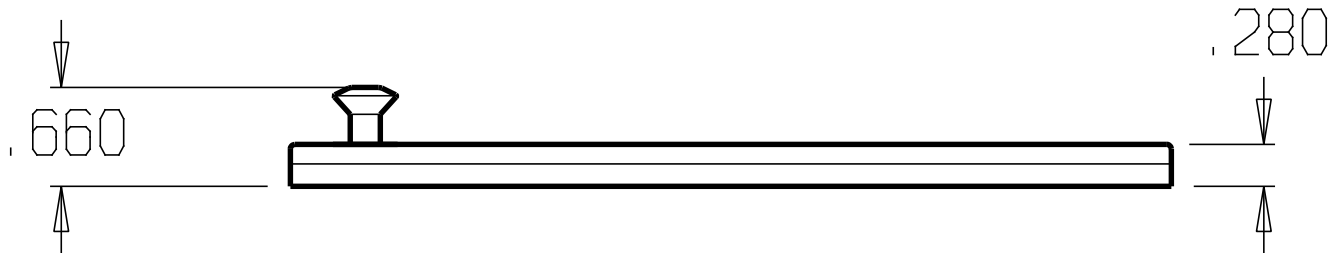
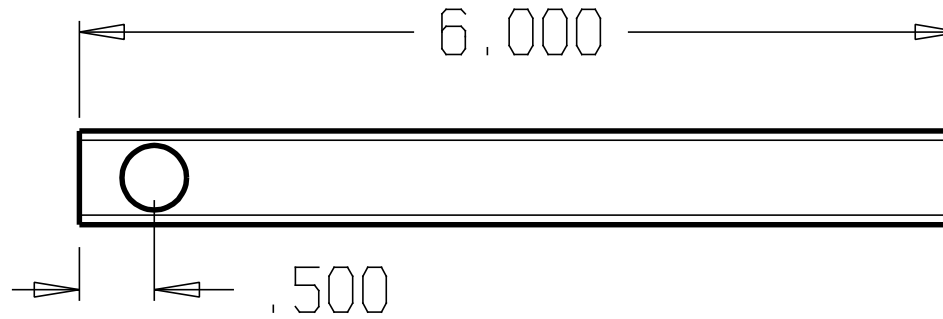

DON-JO MFG. INC.

| | | | | |
|----------|--------|--------------|---------------|-------|
| DESIGNER | SIZE A | DATE: 6/3/04 | PART NO. SB-6 | REV |
| APPROVED | SCALE | RELEASE DATE | WEIGHT | SHEET |

| REVISIONS | | | | |
|-----------|-----|-----------|------|----------|
| ZONE | REV | FINISHES: | DATE | APPROVED |
| | | 628 | | |

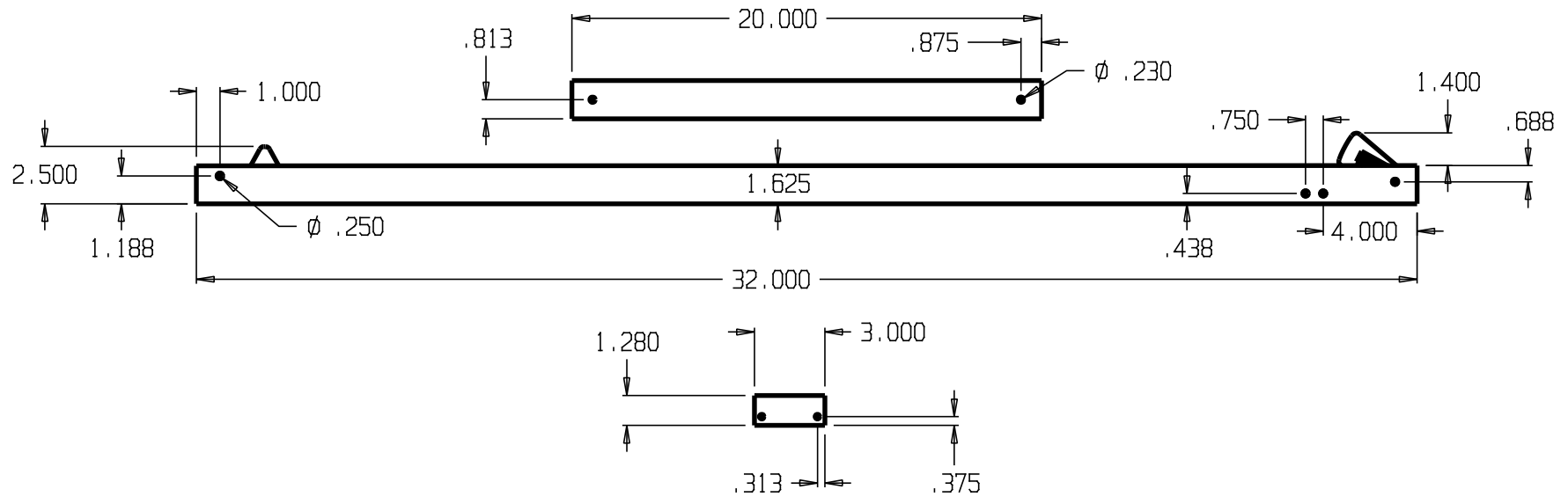

DON-JO MFG. INC.

| | | | | |
|----------|-----------|-----------------|-------------------|-------|
| DESIGNER | SIZE A | DATE: 4/5/04 | PART NO. #2011 | REV |
| APPROVED | SCALE | RELEASE DATE | WEIGHT | SHEET |

| REVISIONS | | | | |
|-----------|-----|-----------|------|----------|
| ZONE | REV | FINISHES: | DATE | APPROVED |
| | | 628 | | |

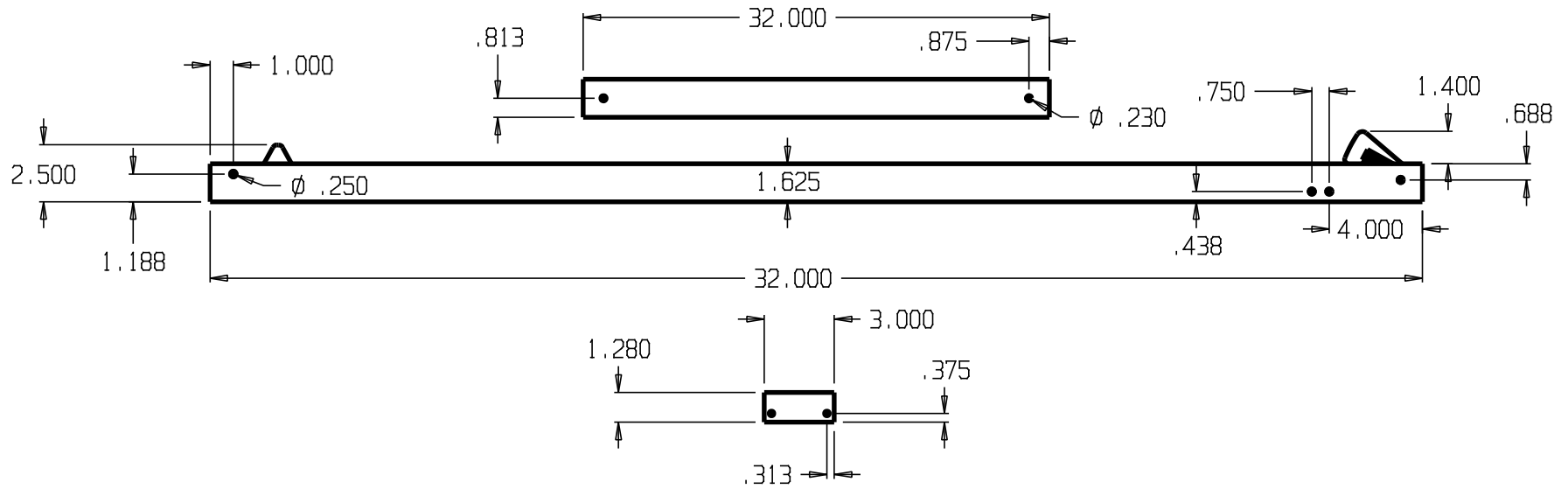

DON-JO MFG. INC.

| | |
|----------|--|
| DESIGNER | |
| APPROVED | |

| | | | |
|-----------|-----------------|-------------------|-------|
| SIZE A | DATE: 4/5/04 | PART NO. #2012 | REV |
| SCALE | RELEASE DATE | WEIGHT | SHEET |

| REVISIONS | | | | |
|-----------|-----|-----------|------|----------|
| ZONE | REV | FINISHES: | DATE | APPROVED |
| | | 628 | | |

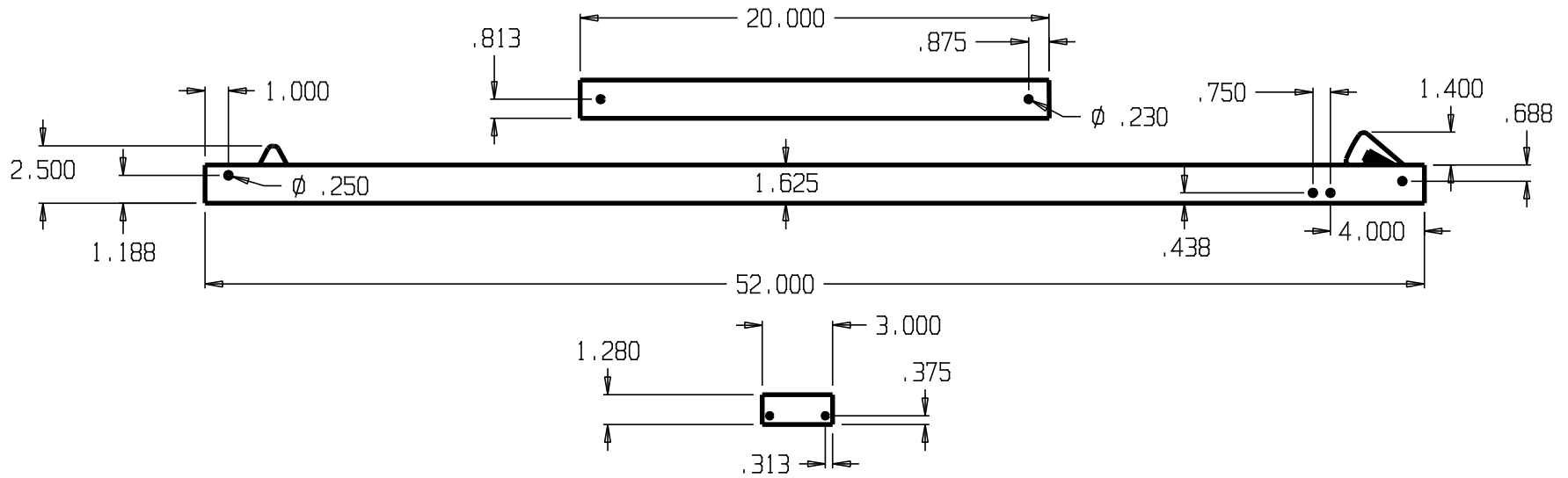

DON-JO MFG. INC.

| | | | | |
|----------|-----------|-----------------|-------------------|-------|
| DESIGNER | SIZE A | DATE: 4/5/04 | PART NO. #2021 | REV |
| APPROVED | SCALE | RELEASE DATE | WEIGHT | SHEET |

| REVISIONS | | | | |
|-----------|-----|-----------|------|----------|
| ZONE | REV | FINISHES: | DATE | APPROVED |
| | | 628 | | |

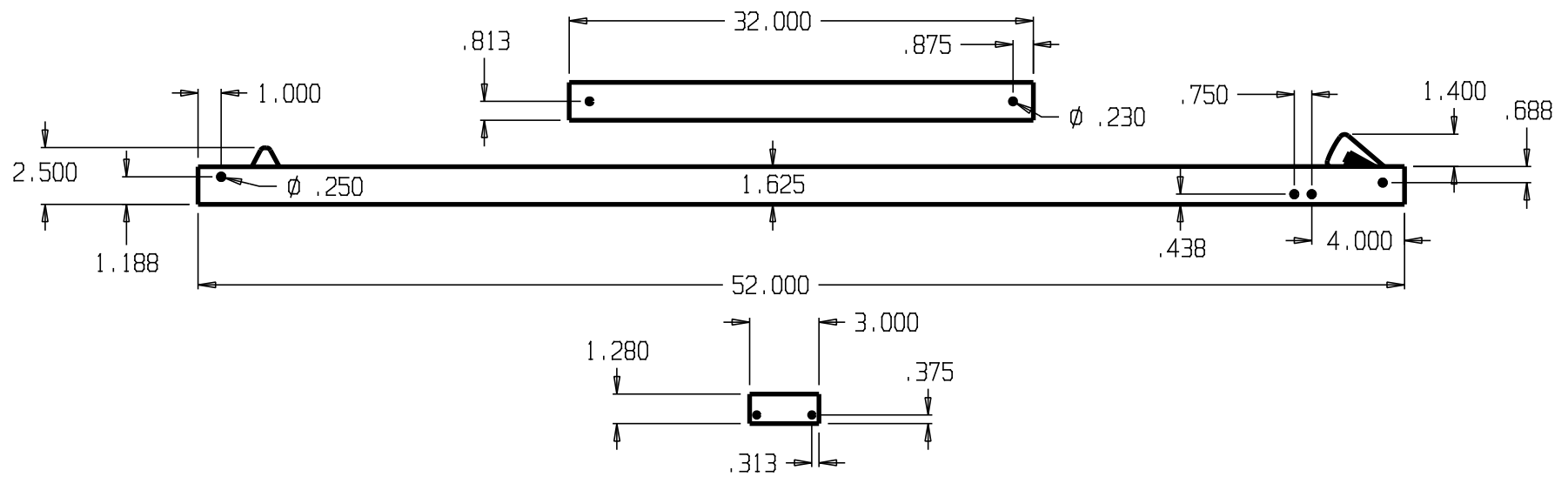

DON-JO MFG. INC.

| | | | | |
|----------|-------|--------------|----------|-------|
| DESIGNER | SIZE | DATE: | PART NO. | REV |
| | A | 4/5/04 | #2022 | |
| APPROVED | SCALE | RELEASE DATE | WEIGHT | SHEET |

| | | | |
|-----------|-----|------|----------|
| DWG NO | | SH | REV |
| REVISIONS | | | |
| ZONE | REV | DATE | APPROVED |
| | | 628 | |

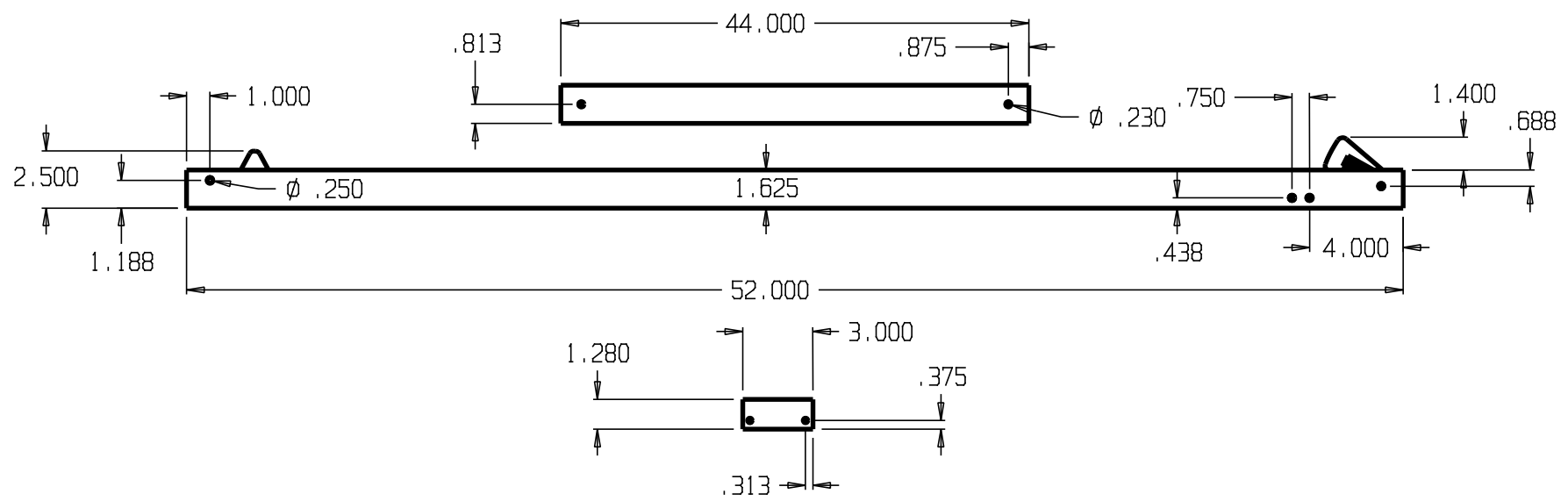

DON-JO MFG. INC.

| | | | | |
|----------|-------|--------------|----------------|-------|
| DESIGNER | SIZE | DATE: 4/5/04 | PART NO. #2023 | REV |
| APPROVED | SCALE | RELEASE DATE | WEIGHT | SHEET |

| REVISIONS | | | | |
|-----------|-----|-------------|------|----------|
| ZONE | REV | FINISHES: | DATE | APPROVED |
| | | MATTE BLACK | | |

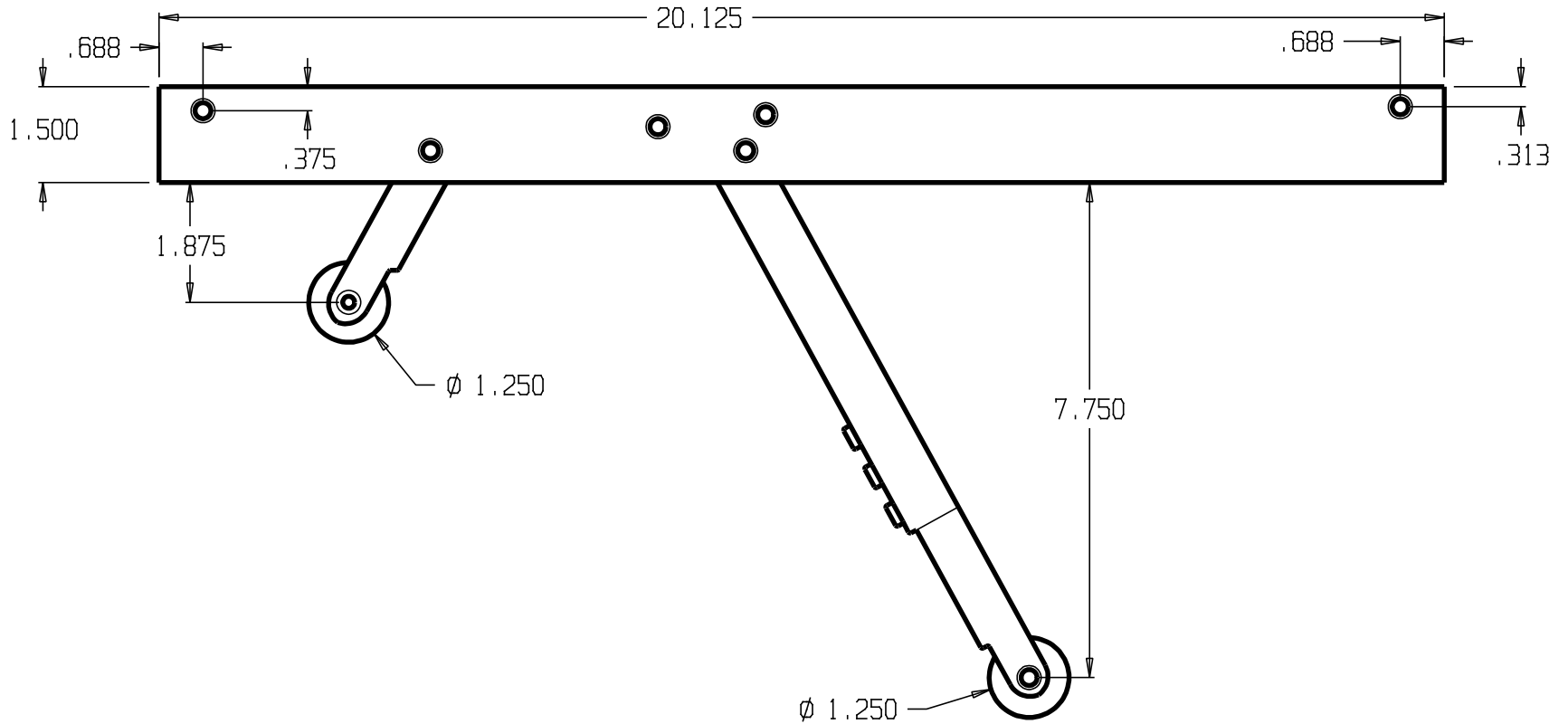

DON-JO MFG. INC.

| | | | | |
|----------|-------|--------------|----------|-------|
| DESIGNER | SIZE | DATE: | PART NO. | REV |
| | A | 4/5/04 | #2040 | |
| APPROVED | SCALE | RELEASE DATE | WEIGHT | SHEET |

| REVISIONS | | | | |
|-----------|-----|-----------|------|----------|
| ZONE | REV | FINISHES: | DATE | APPROVED |
| | | ALLUMINUM | | |

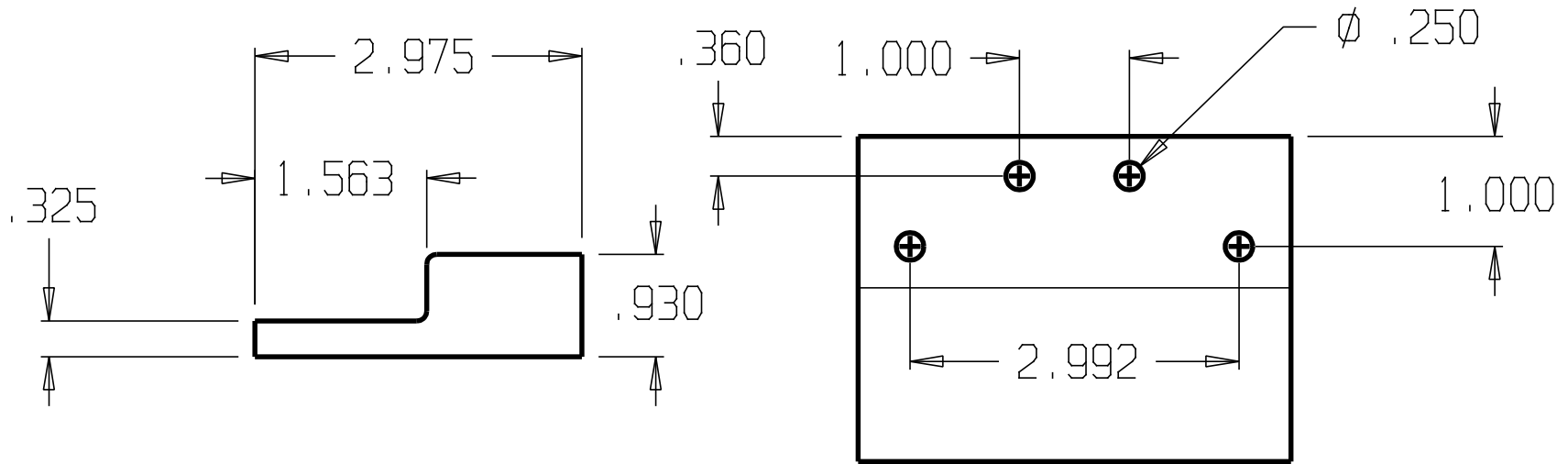

DON-JO MFG. INC.

| | | | | | |
|----------|--|-----------|-----------------|-------------------|-------|
| DESIGNER | | SIZE A | DATE: 4/5/04 | PART NO. #2050 | REV |
| APPROVED | | SCALE | RELEASE DATE | WEIGHT | SHEET |

| REVISIONS | | | | |
|-----------|-----|------------|------|----------|
| ZONE | REV | FINISHES : | DATE | APPROVED |
| | | ALUMINUM | | |

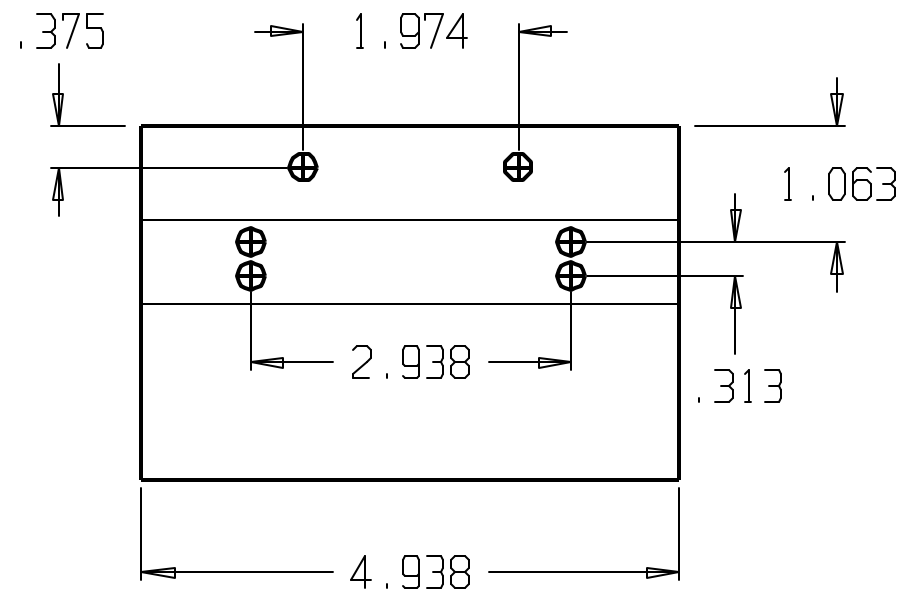
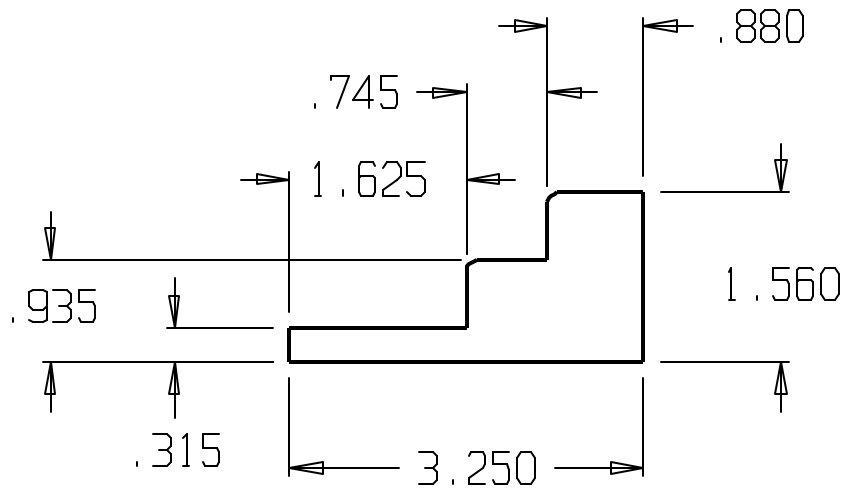

DON-JO MFG. INC.

| | | | | |
|----------|-----------|----------------|-------------------|-------|
| DESIGNER | SIZE A | DATE 4/5/04 | PART NO. #2051 | REV |
| APPROVED | SCALE | RELEASE DATE | WEIGHT | SHEET |

| REVISIONS | | | | |
|-----------|-----|------------|------|----------|
| ZONE | REV | FINISHES: | DATE | APPROVED |
| | | PRIME COAT | | |

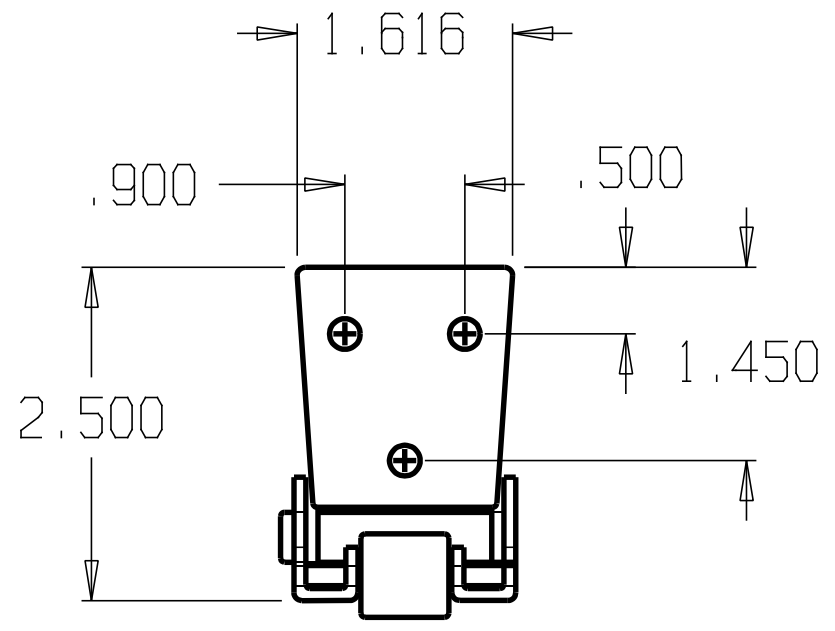
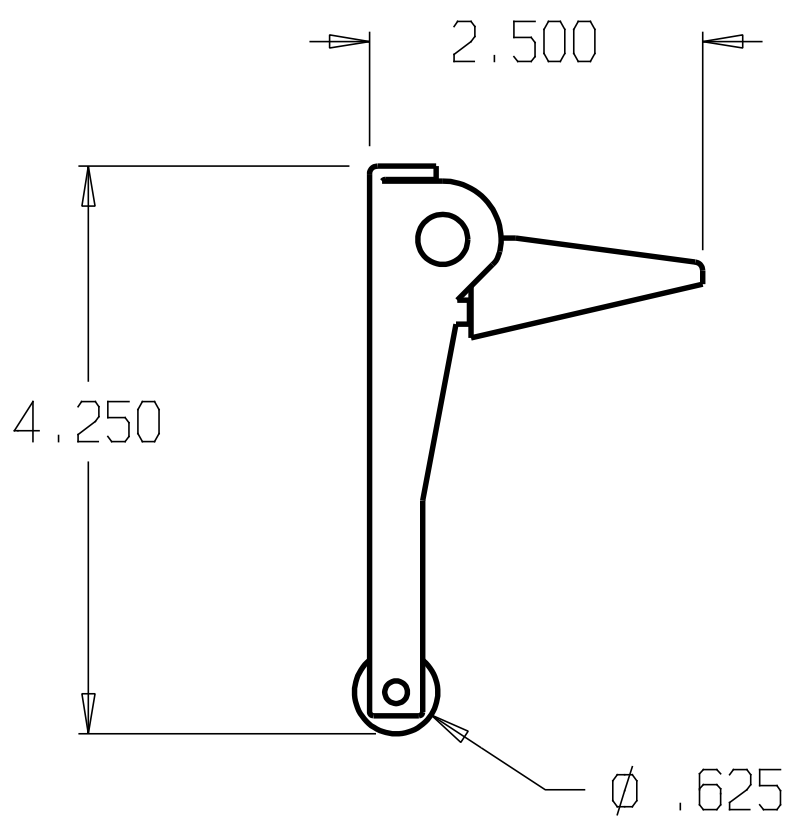

| | | | | |
|------------------|-----------|-----------------|-------------------|-------|
| DON-JO MFG. INC. | | | | |
| DESIGNER | SIZE A | DATE: 4/5/04 | PART NO. #2060 | REV |
| APPROVED | SCALE | RELEASE DATE | WEIGHT | SHEET |

| REVISIONS | | | | |
|-----------|-----|-----------|------|----------|
| ZONE | REV | FINISHES: | DATE | APPROVED |
| | | 626 | | |

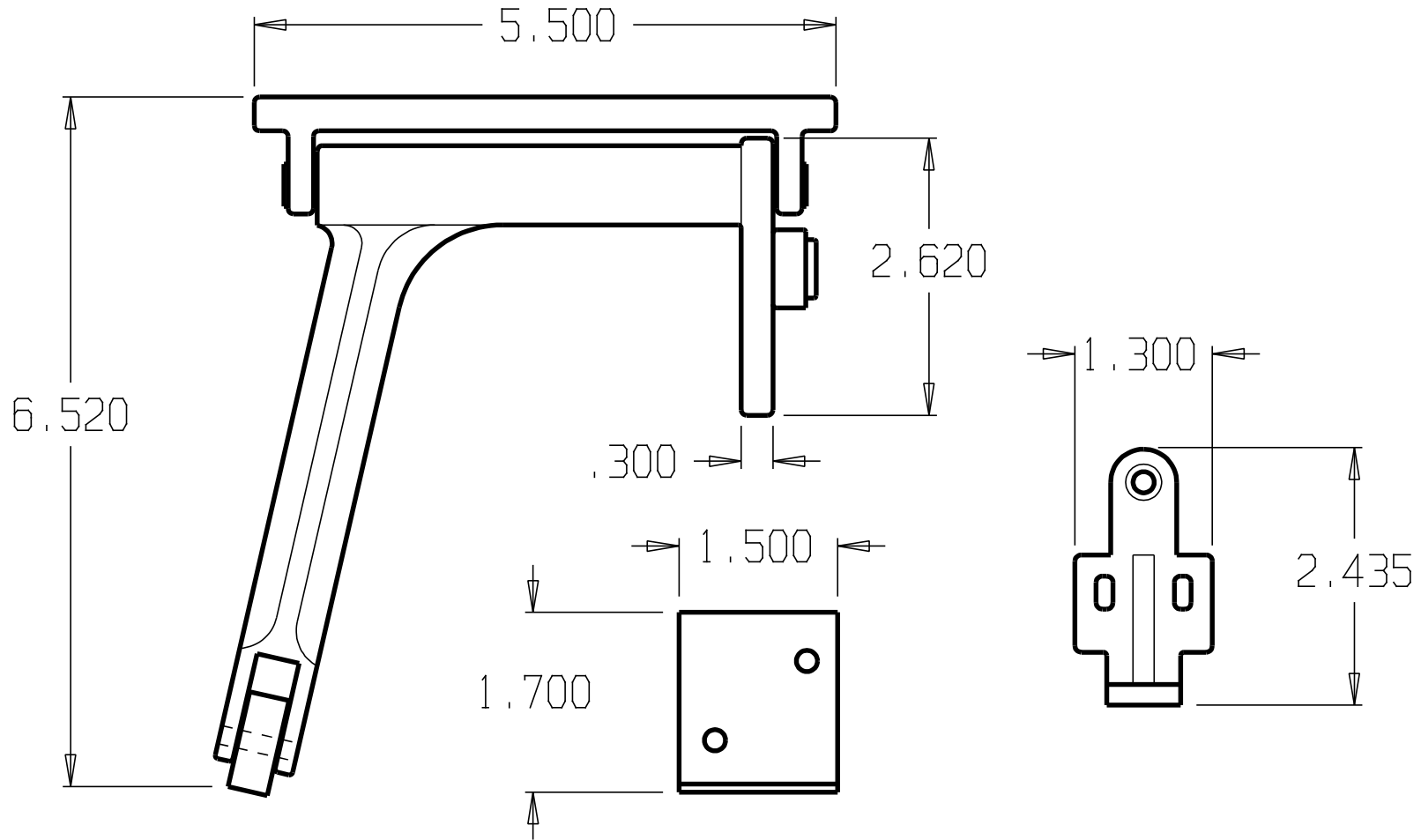

DON-JO MFG. INC.

| | | | | |
|----------|-----------|-----------------|-------------------|-------|
| DESIGNER | SIZE A | DATE: 4/5/04 | PART NO. #2080 | REV |
| APPROVED | SCALE | RELEASE DATE | WEIGHT | SHEET |

| REVISIONS | | | | |
|-----------|-----|-----------|------|----------|
| ZONE | REV | FINISHES: | DATE | APPROVED |
| | | 630 | | |

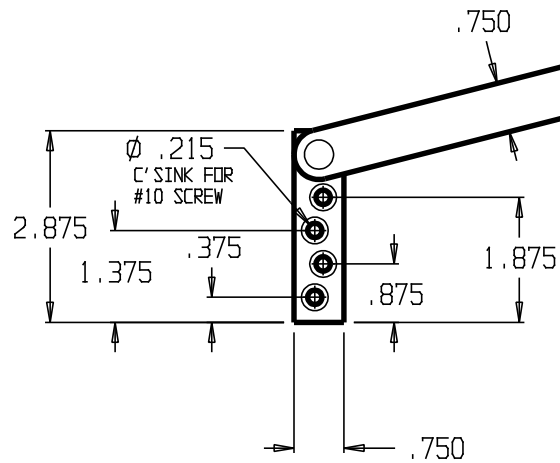
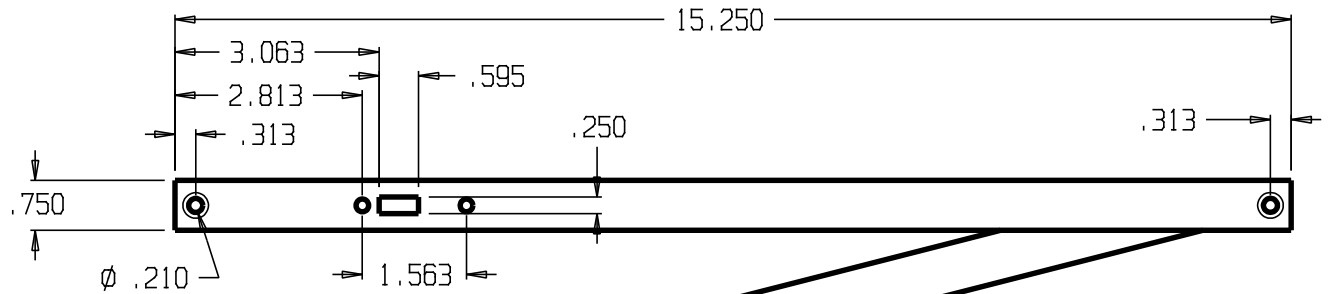

DON-JO MFG. INC.

| | | | | |
|----------|-------|--------------|----------|-------|
| DESIGNER | SIZE | DATE: | PART NO. | REV |
| | A | 4/21/04 | #3023 | |
| APPROVED | SCALE | RELEASE DATE | WEIGHT | SHEET |
| | | | | |

| REVISIONS | | | | |
|-----------|-----|-----------|------|----------|
| ZONE | REV | FINISHES: | DATE | APPROVED |
| | | 630 | | |

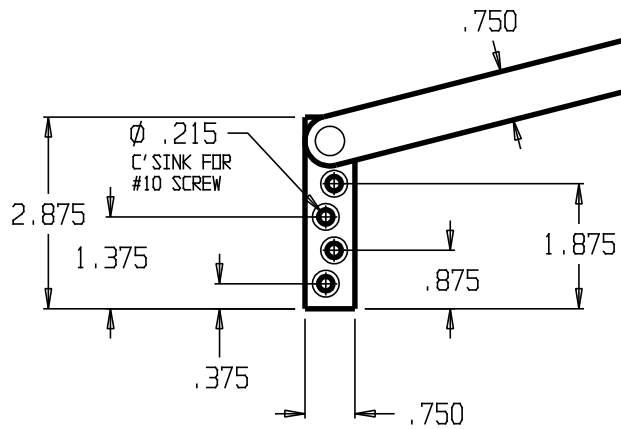
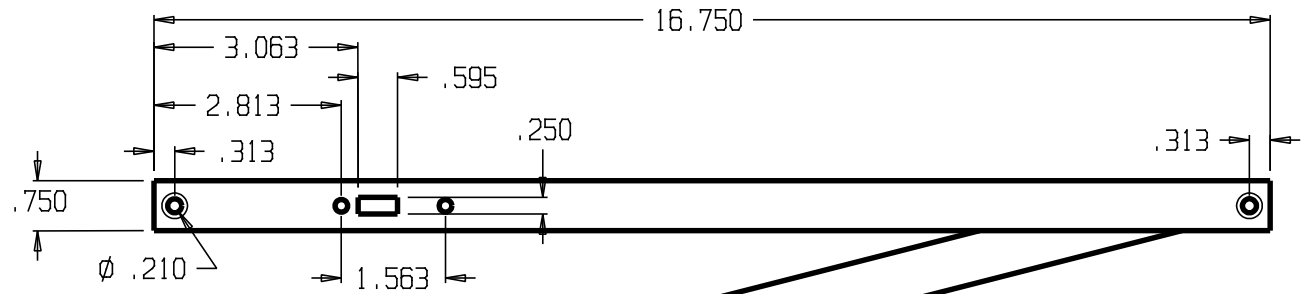

DON-JO MFG. INC.

| | | | | |
|----------|-------|--------------|----------|-------|
| DESIGNER | SIZE | DATE: | PART NO. | REV |
| | A | 4/21/04 | #3024 | |
| APPROVED | SCALE | RELEASE DATE | WEIGHT | SHEET |

| REVISIONS | | | | |
|-----------|-----|-----------|------|----------|
| ZONE | REV | FINISHES: | DATE | APPROVED |
| | | 630 | | |

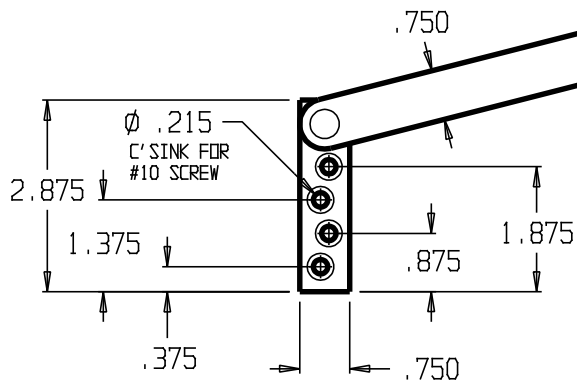
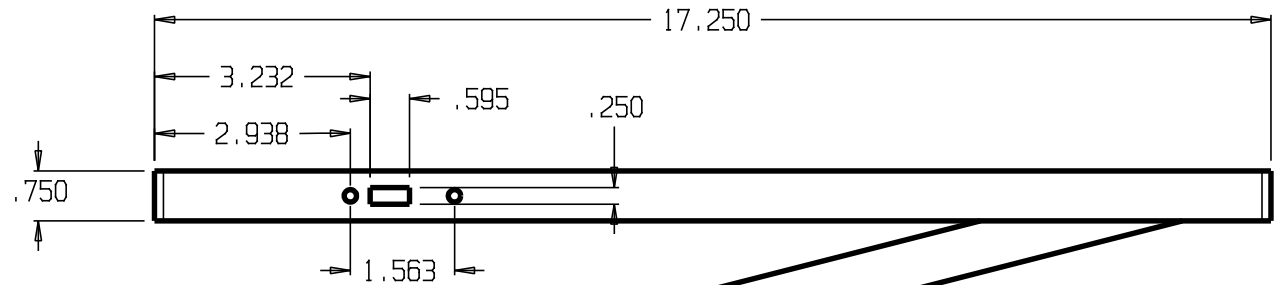

DON-JO MFG. INC.

| | | | | |
|----------|-------|--------------|----------|-------|
| DESIGNER | SIZE | DATE: | PART NO. | REV |
| | A | 4/21/04 | #3123 | |
| APPROVED | SCALE | RELEASE DATE | WEIGHT | SHEET |
| | | | | |

| REVISIONS | | | | |
|-----------|-----|-----------|------|----------|
| ZONE | REV | FINISHES: | DATE | APPROVED |
| | | 630 | | |

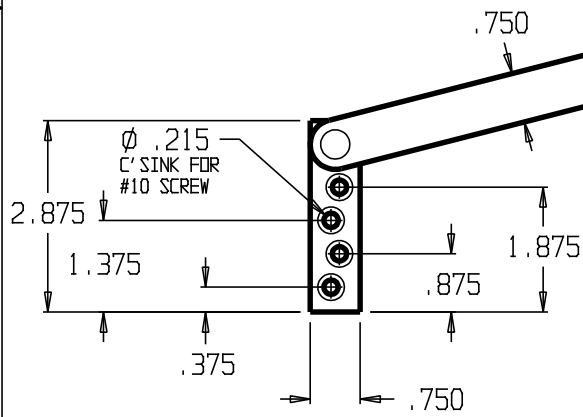
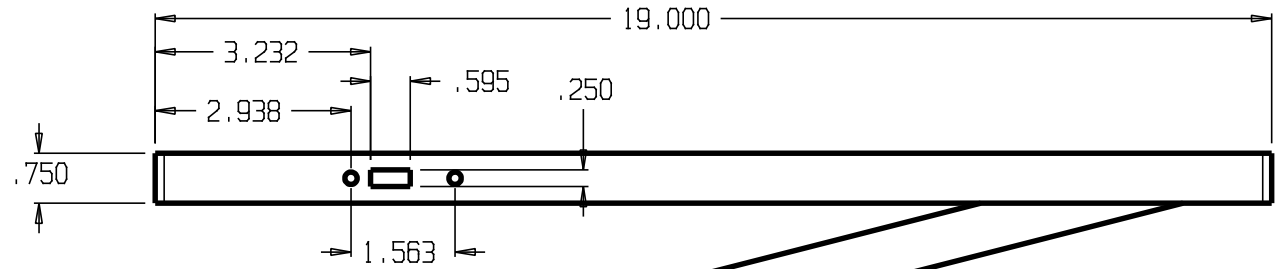

DON-JO MFG. INC.

| | | | | |
|----------|-----------|------------------|-------------------|-------|
| DESIGNER | SIZE A | DATE: 4/21/04 | PART NO. #3124 | REV |
| APPROVED | SCALE | RELEASE DATE | WEIGHT | SHEET |

| REVISIONS | | | | |
|-----------|-----|-----------|------|----------|
| ZONE | REV | FINISHES: | DATE | APPROVED |
| | | 630 | | |

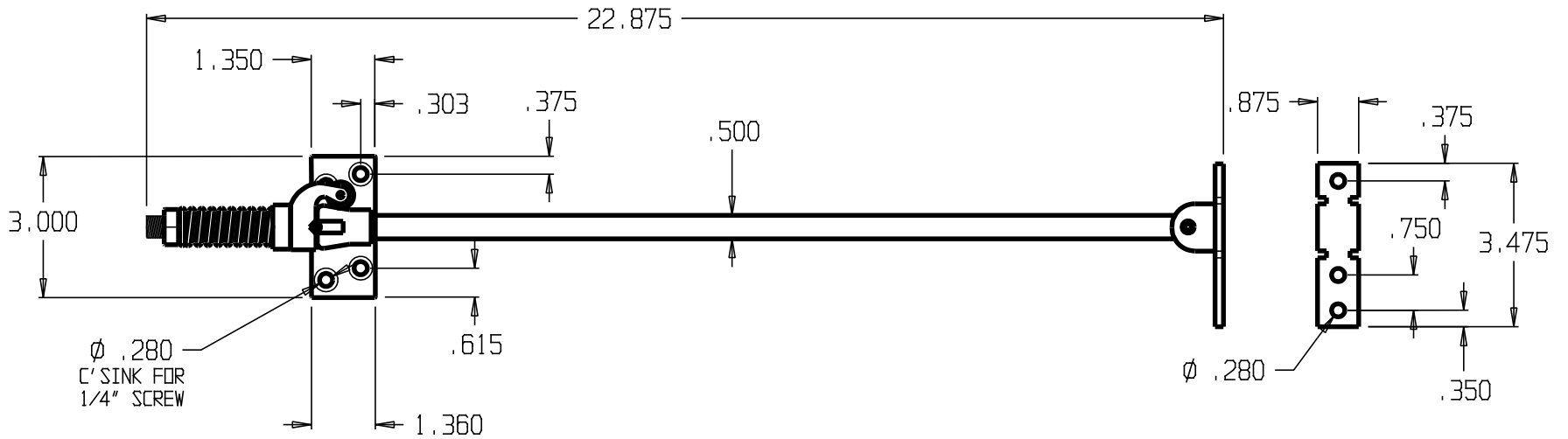

DON-JO MFG. INC.

| | | | | |
|----------|-----------|------------------|-------------------|-------|
| DESIGNER | SIZE A | DATE: 4/26/04 | PART NO. #3212 | REV |
| APPROVED | SCALE | RELEASE DATE | WEIGHT | SHEET |

| REVISIONS | | | | |
|-----------|-----|-----------|------|----------|
| ZONE | REV | FINISHES: | DATE | APPROVED |
| | | 630 | | |

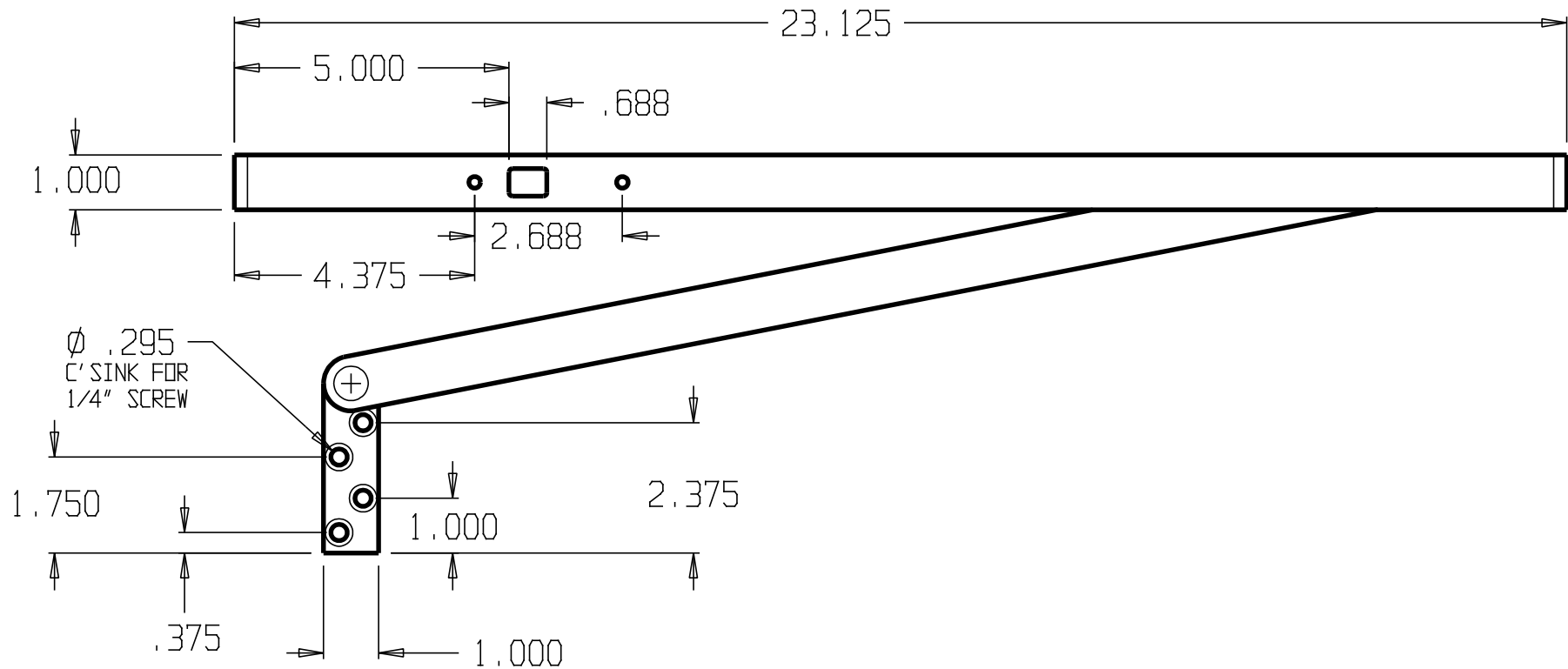

DON-JO MFG. INC.

| | | | | |
|----------|-------|--------------|----------|-------|
| DESIGNER | SIZE | DATE: | PART NO. | REV |
| | A | 4/27/04 | #3323 | |
| APPROVED | SCALE | RELEASE DATE | WEIGHT | SHEET |

| REVISIONS | | | | |
|-----------|-----|-----------|------|----------|
| ZONE | REV | FINISHES: | DATE | APPROVED |
| | | 630 | | |

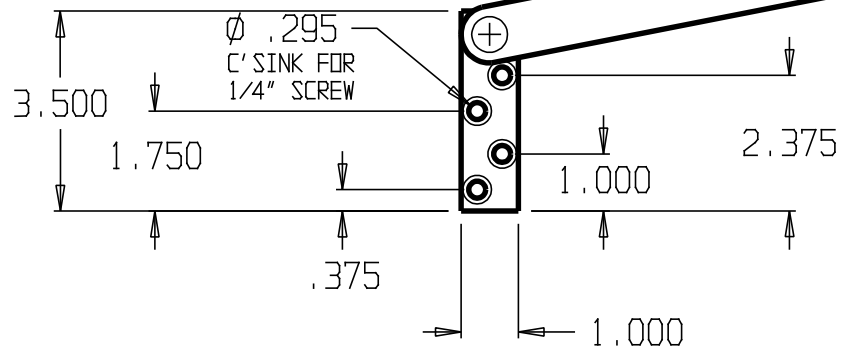
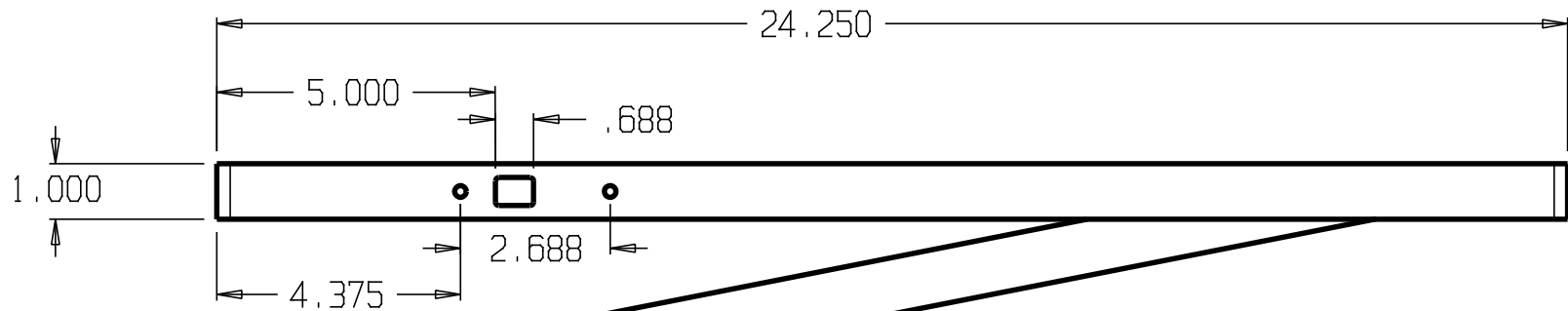

DON-JO MFG. INC.

| | | | | |
|----------|-----------|------------------|-------------------|-------|
| DESIGNER | SIZE A | DATE: 4/27/04 | PART NO. #3324 | REV |
| APPROVED | SCALE | RELEASE DATE | WEIGHT | SHEET |

| REVISIONS | | | | |
|-----------|-----|-----------|------|----------|
| ZONE | REV | FINISHES: | DATE | APPROVED |
| | | 626 | | |

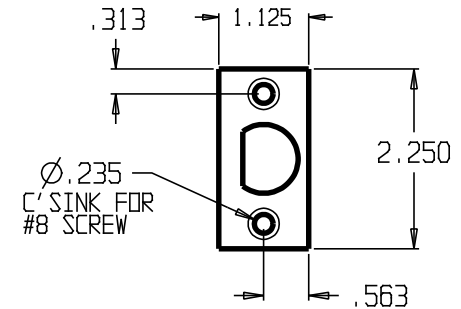
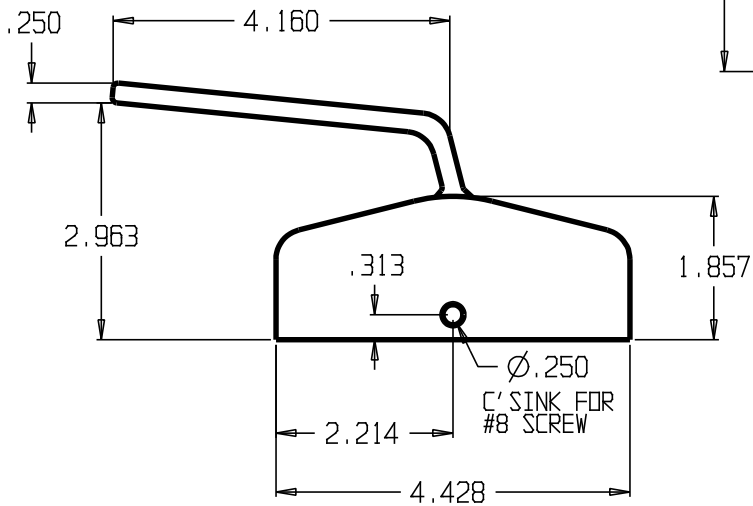
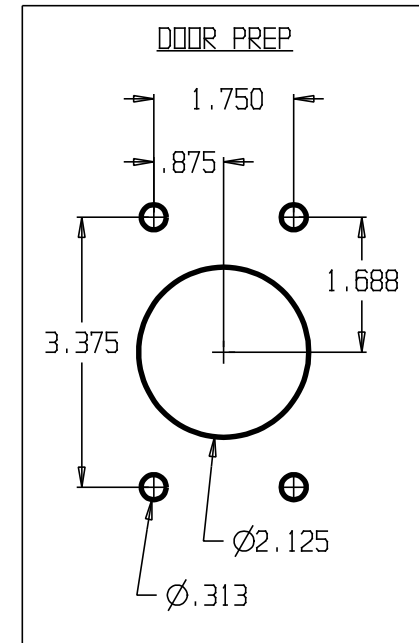
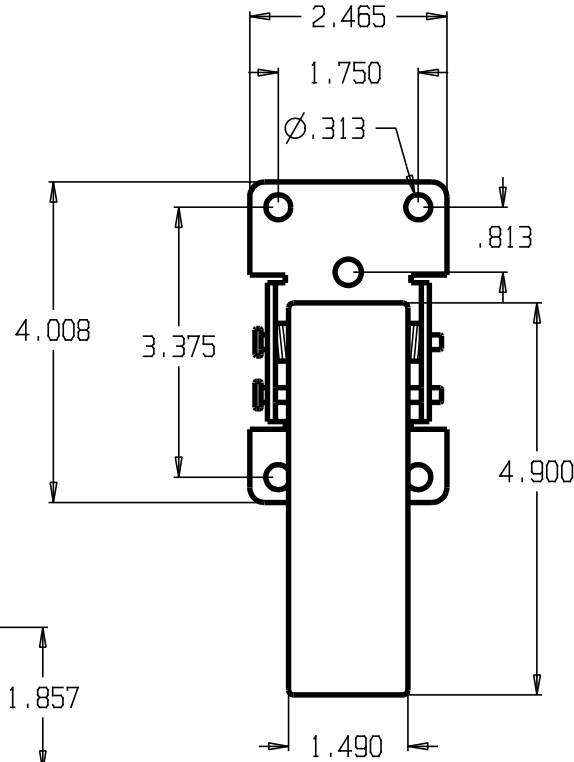
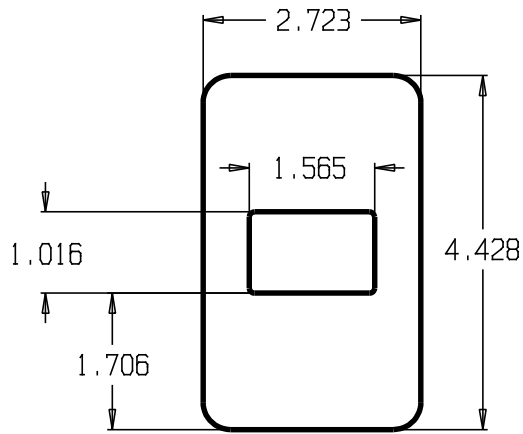

DON-JO MFG. INC.

| | | | | |
|----------|-----------|------------------|-------------------|-------|
| DESIGNER | SIZE A | DATE: 3/11/04 | PART NO. #4500 | REV |
| APPROVED | SCALE | RELEASE DATE | WEIGHT | SHEET |

| REVISIONS | | | | |
|-----------|-----|-----------|------|----------|
| ZONE | REV | FINISHES: | DATE | APPROVED |
| | | 626 | | |

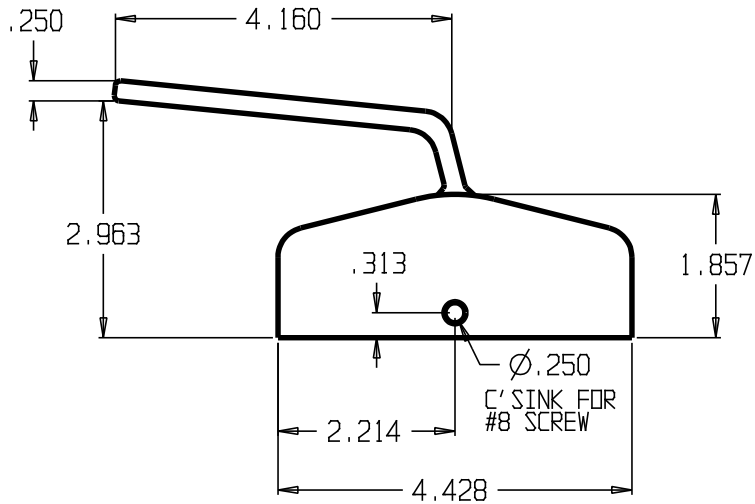
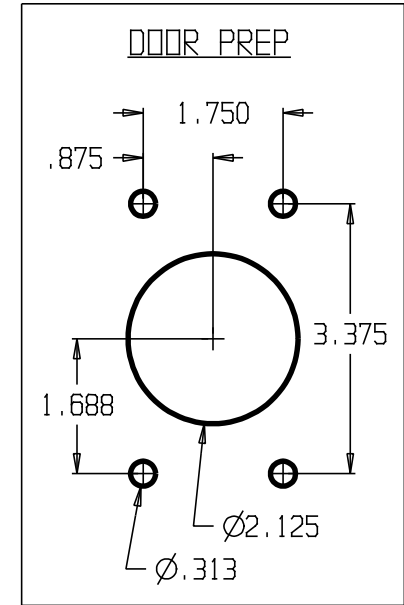
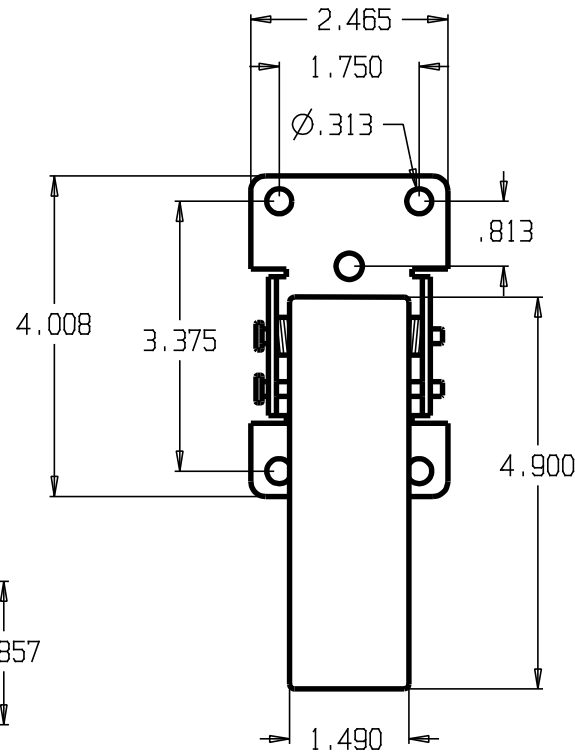
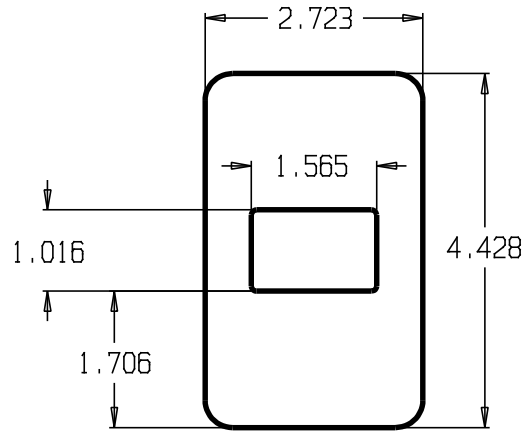

*5" BACKSET

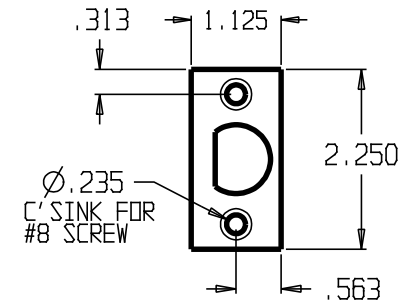

DON-JO MFG. INC.

| | | | | |
|----------|-----------|------------------|-------------------|-------|
| DESIGNER | SIZE A | DATE: 3/11/04 | PART NO. #4550 | REV |
| APPROVED | SCALE | RELEASE DATE | WEIGHT | SHEET |

| REVISIONS | | | |
|-----------|-----|-----------|--------|
| ZONE | REV | FINISHES: | GAUGE: |
| | | 626 | |

WITH VINYL CHAIN COVER
CHAIN LENGTH: 20.5"

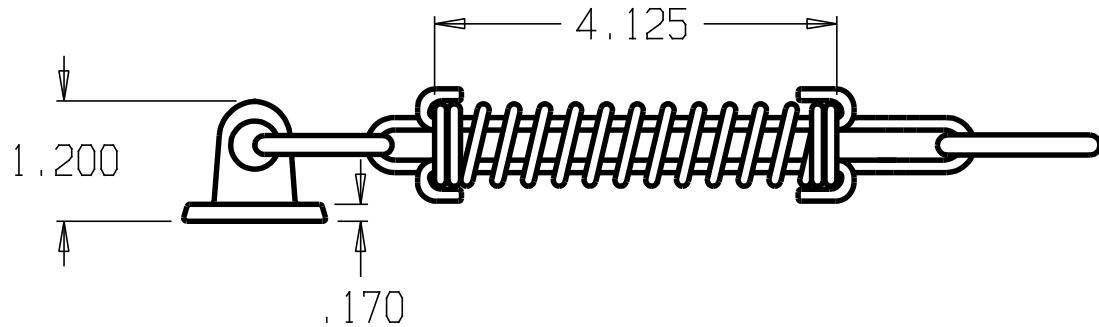
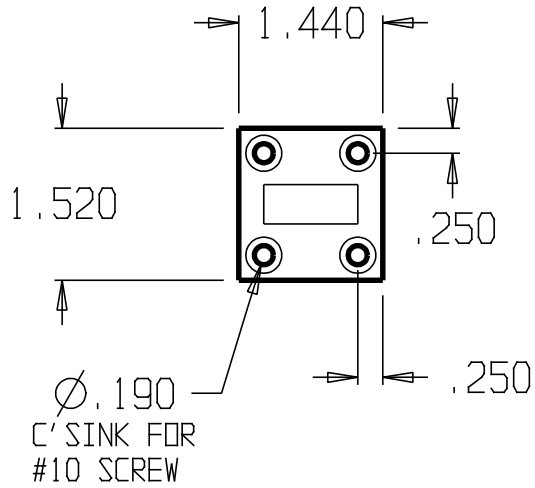

| | | | | | |
|------------------|--|-------|--------------|-----------|-------|
| DON-JO MFG. INC. | | SIZE | DATE: | PART NO. | REV |
| DESIGNER | | A | 5/20/04 | HDCC-2012 | |
| APPROVED | | SCALE | RELEASE DATE | WEIGHT | SHEET |

| REVISIONS | | | |
|-----------|-----|-----------|--------|
| ZONE | REV | FINISHES: | GAUGE: |
| | | 626 | |

WITH VINYL CHAIN COVER
CHAIN LENGTH: 25.5"

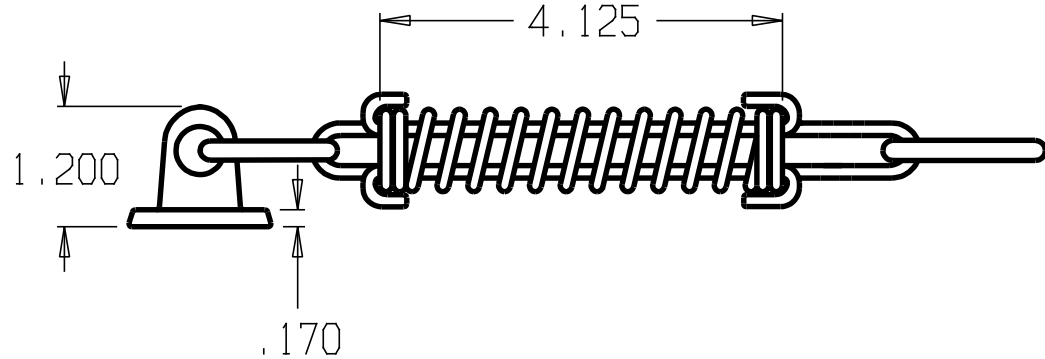
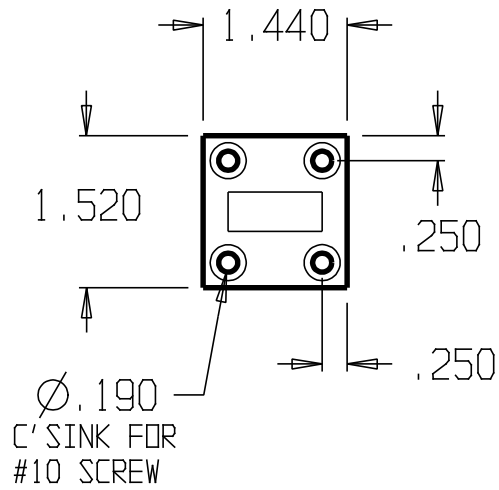

| | | | | | |
|------------------|--|-------|--------------|-----------|-------|
| DON-JO MFG. INC. | | SIZE | DATE: | PART NO. | REV |
| DESIGNER | | A | 5/20/04 | HDCC-2512 | |
| APPROVED | | SCALE | RELEASE DATE | WEIGHT | SHEET |

| REVISIONS | | | |
|-----------|-----|-----------|--------|
| ZONE | REV | FINISHES: | GAUGE: |
| | | 626 | |

WITH VINYL CHAIN COVER
CHAIN LENGTH: 30.5"

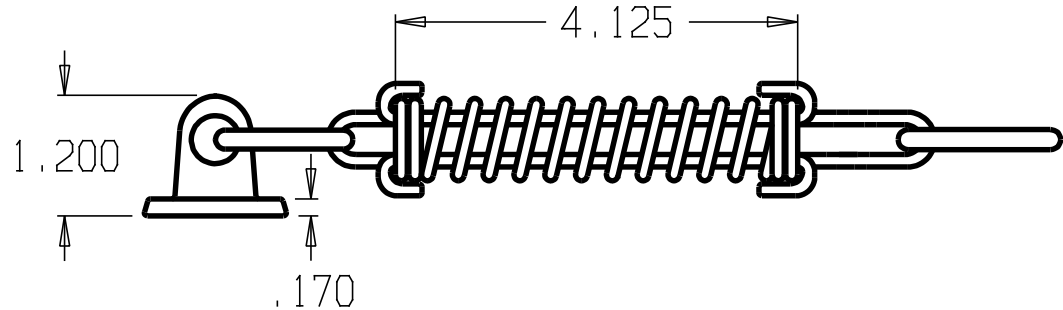
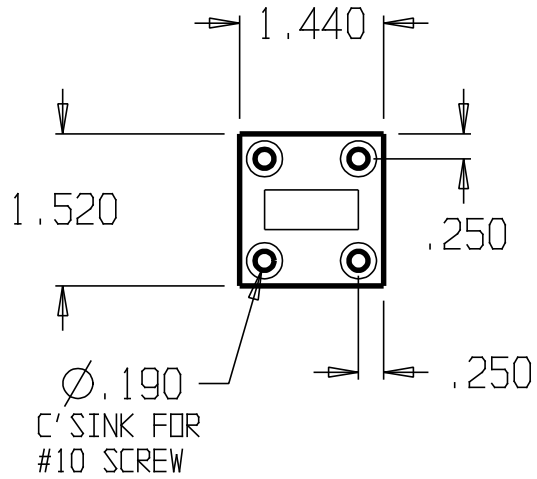

DON-JO MFG. INC.

| | | | | |
|----------|-----------|------------------|-----------------------|-------|
| DESIGNER | SIZE A | DATE: 5/20/04 | PART NO. HDCC-3012 | REV |
| APPROVED | SCALE | RELEASE DATE | WEIGHT | SHEET |

| REVISIONS | | | |
|-----------|-----|------------|------------|
| ZONE | REV | FINISHES: | GALVE: |
| | | GALVANEALD | 18ga. .050 |

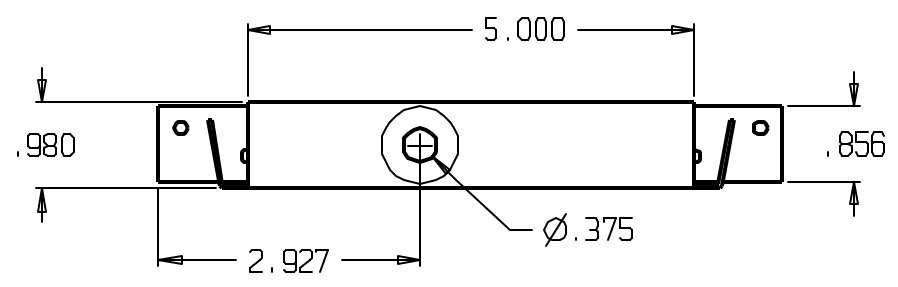
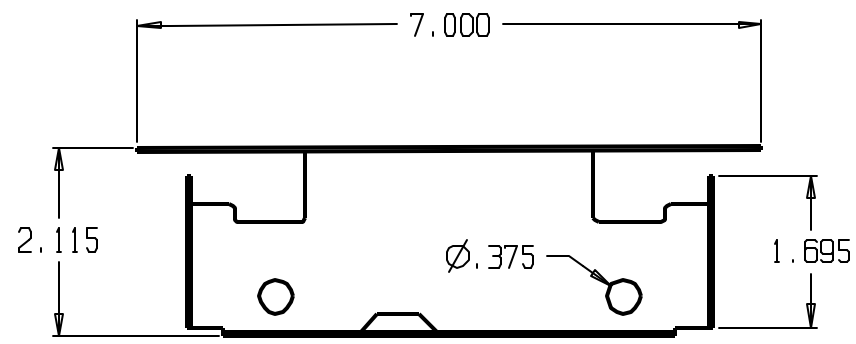
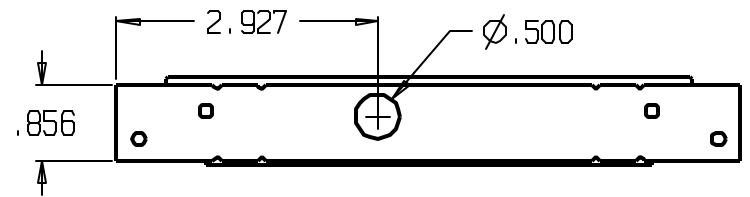

DON-JO MFG. INC.

| | | | | |
|------------------|-----------|-----------------|---------------------|-------|
| DESIGNER D.R. | SIZE A | DATE 4/18/09 | PART NO. 534 MWA | REV |
| | SCALE | RELEASE DATE | WEIGHT | SHEET |

| REVISIONS | | | |
|-----------|-----|------------|------------|
| ZONE | REV | FINISHES: | GUAGE: |
| | | GALVANEALD | 18ga. .050 |

2pc SET

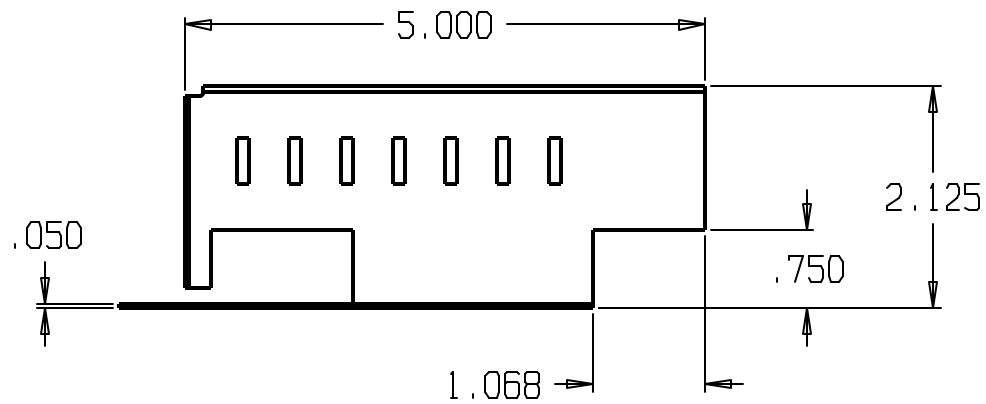
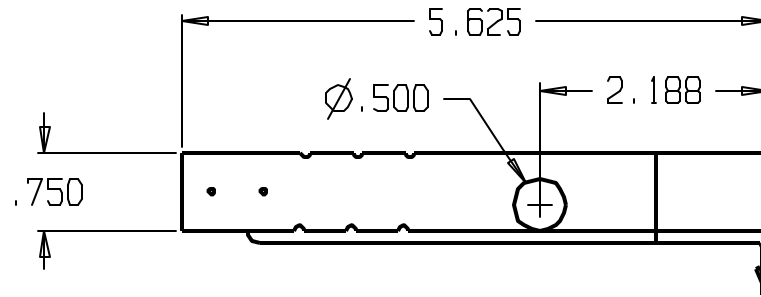

DON-JO MFG. INC.

| | | | |
|----------|--------------|----------|-------|
| DESIGNER | DATE | PART NO. | REV |
| D.R. | 1/27/10 | 834 ADJ | |
| SCALE | RELEASE DATE | WEIGHT | SHEET |

| | | |
|---------|----|-----|
| DWG NO. | SH | REV |
|---------|----|-----|

| REVISIONS | | |
|-----------|-----|------------|
| ZONE | REV | FINISHES: |
| | | DU & SL |
| | | Gauge: |
| | | 13ga. .095 |

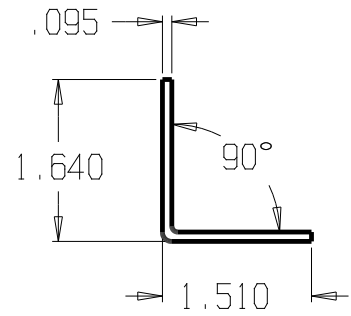
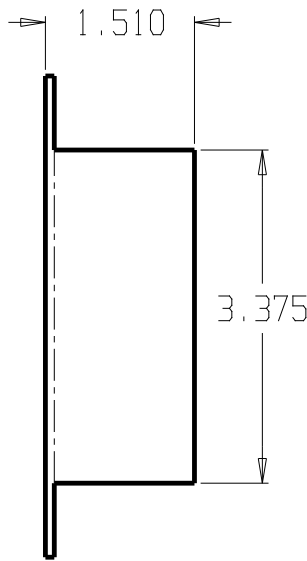
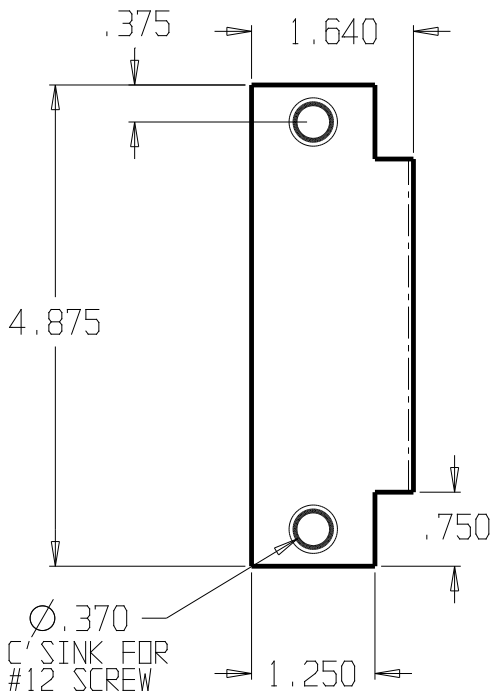

DON-JO MFG. INC.

DESIGNER
APPROVED

SIZE
A

DATE:
6/26/14

PART NO.
AF-260

REV

SCALE

RELEASE DATE

WEIGHT

SHEET

| | | |
|---------|----|-----|
| DWG NO. | SH | REV |
|---------|----|-----|

| REVISIONS | | |
|-----------|-----|-----------------------|
| ZONE | REV | FINISHES: |
| | | DU & SL |
| | | GALUGE: 13ga. .095 |

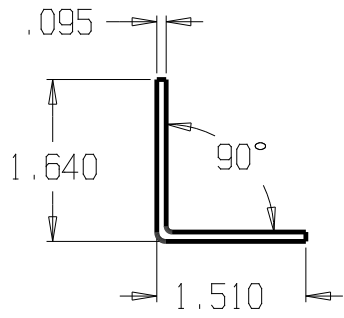
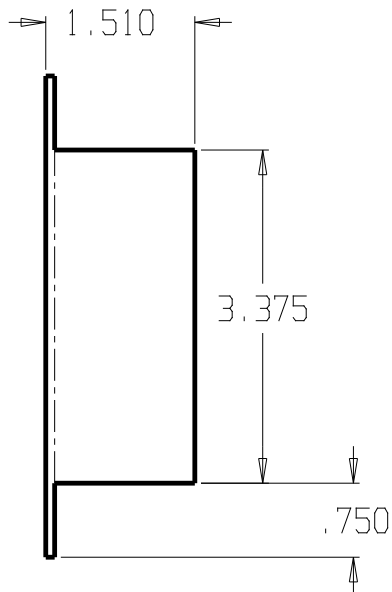
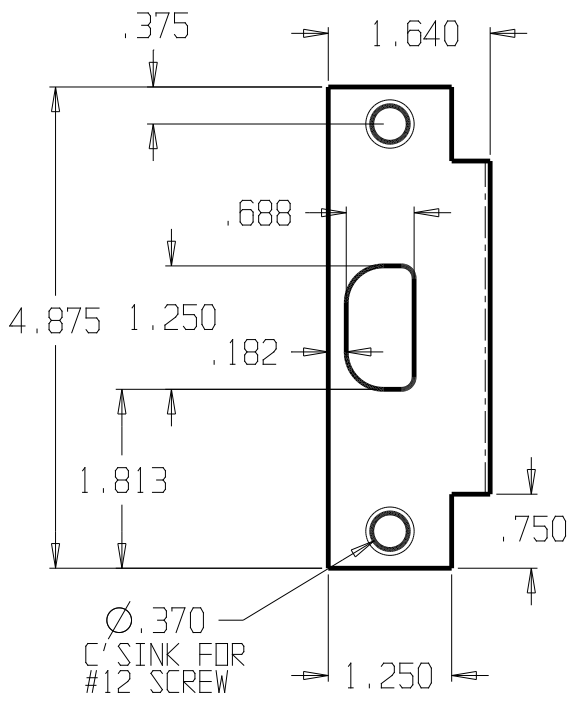

DON-JO MFG. INC.

| | | | | |
|----------|-----------|------------------|--------------------|-------|
| DESIGNER | SIZE A | DATE: 6/26/14 | PART NO. AF-261 | REV |
| APPROVED | SCALE | RELEASE DATE | WEIGHT | SHEET |

| REVISIONS | | | |
|-----------|-----|-----------|------------|
| ZONE | REV | FINISHES: | GALIGE: |
| | | DU & SL | 13ga. .095 |

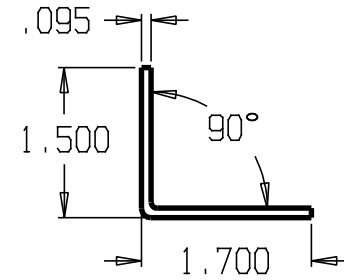
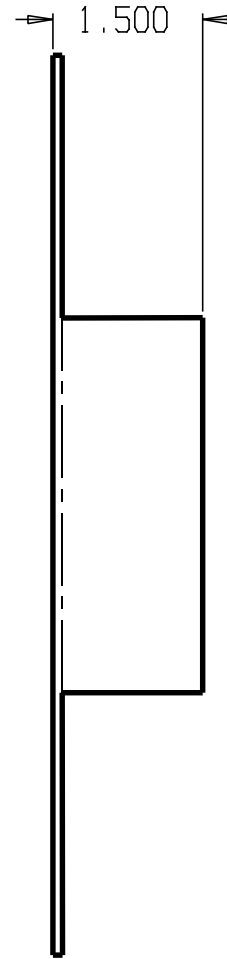
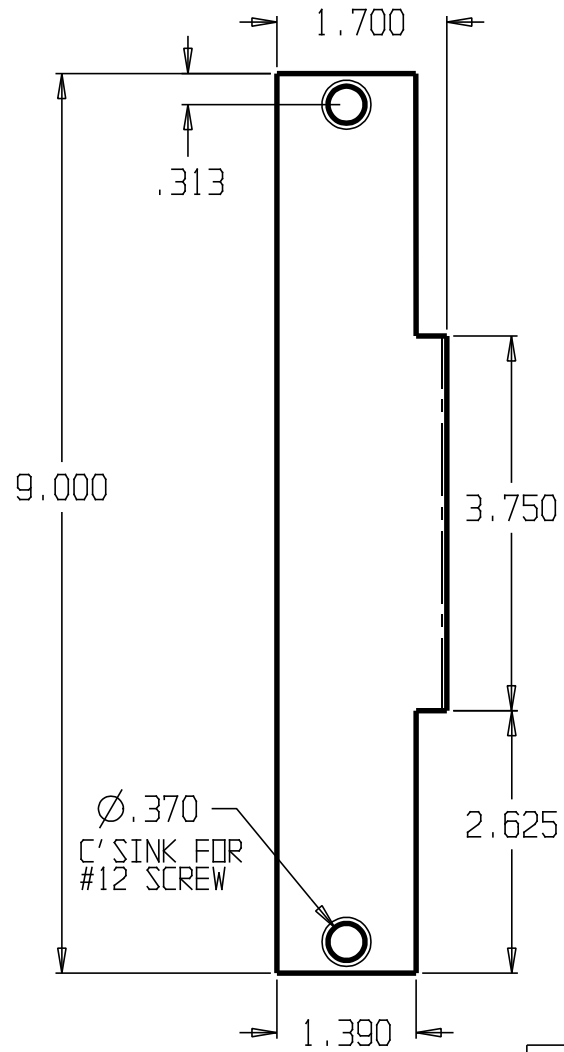

DON-JO MFG. INC.

| | | | | |
|----------|-------|--------------|----------|-------|
| DESIGNER | SIZE | DATE: | PART NO. | REV |
| | A | 4/30/04 | AF-29 | |
| APPROVED | SCALE | RELEASE DATE | WEIGHT | SHEET |
| | | | | |

| REVISIONS | | | |
|-----------|-----|-----------|------------|
| ZONE | REV | FINISHES: | GUAGE: |
| | | DU & SL | 13ga. .095 |

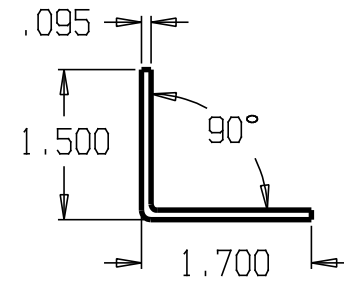
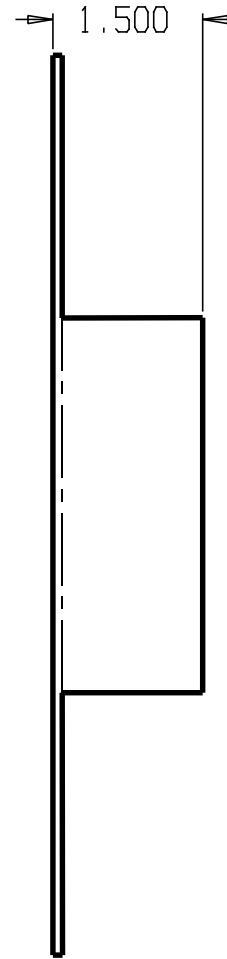
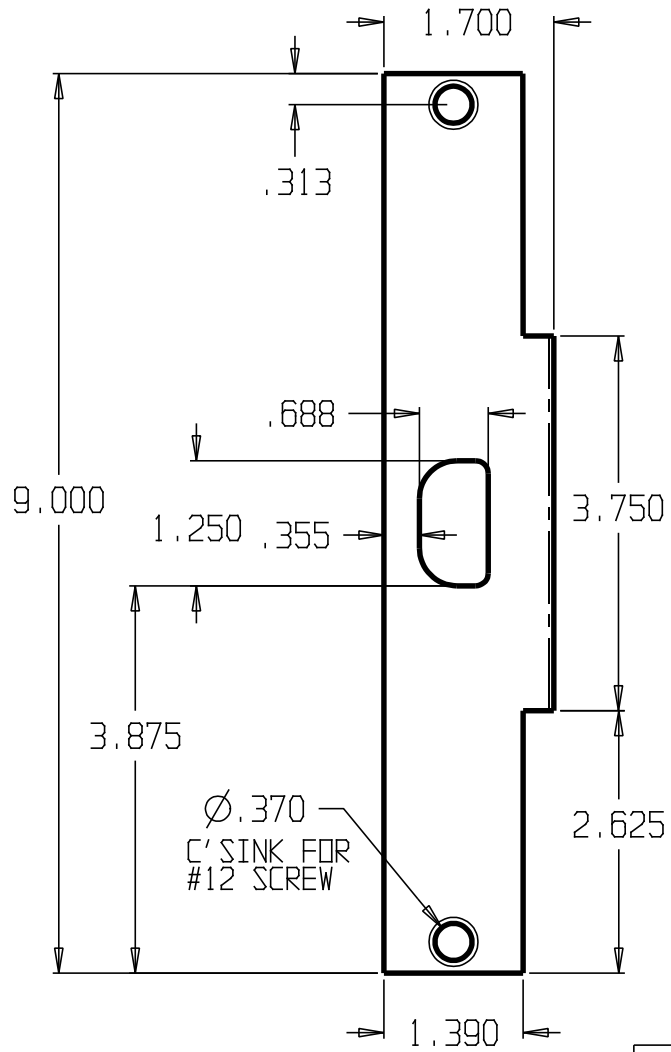

DON-JO MFG. INC.

| | | | | |
|----------|-------|--------------|----------|-------|
| DESIGNER | SIZE | DATE: | PART NO. | REV |
| | A | 4/30/04 | AF-291 | |
| APPROVED | SCALE | RELEASE DATE | WEIGHT | SHEET |
| | | | | |

| REVISIONS | | | |
|-----------|-----|-----------|------------|
| ZONE | REV | FINISHES: | GUAGE: |
| | | DU & SL | 13ga. .095 |

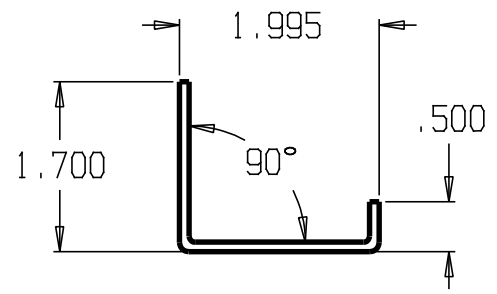
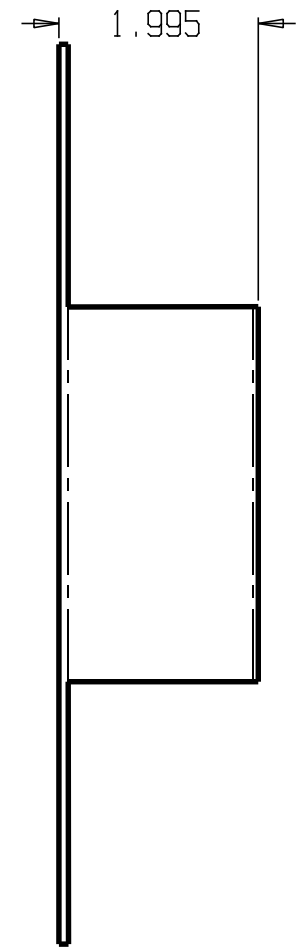
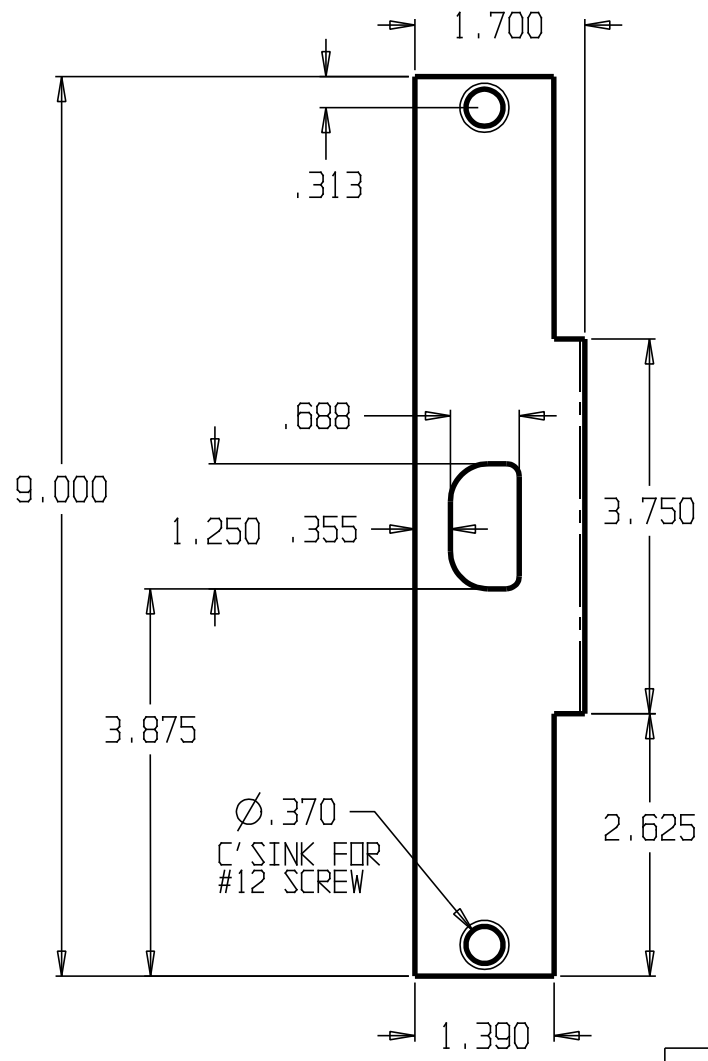

DON-JO MFG. INC.

| | | | | |
|----------|-------|--------------|----------|-------|
| DESIGNER | SIZE | DATE: | PART NO. | REV |
| | A | 4/30/04 | AF-291L | |
| APPROVED | SCALE | RELEASE DATE | WEIGHT | SHEET |
| | | | | |

| REVISIONS | | | |
|-----------|-----|-----------|------------|
| ZONE | REV | FINISHES: | GALUGE: |
| | | DU & SL | 13ga. .095 |

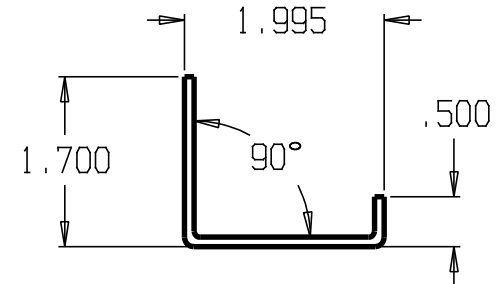
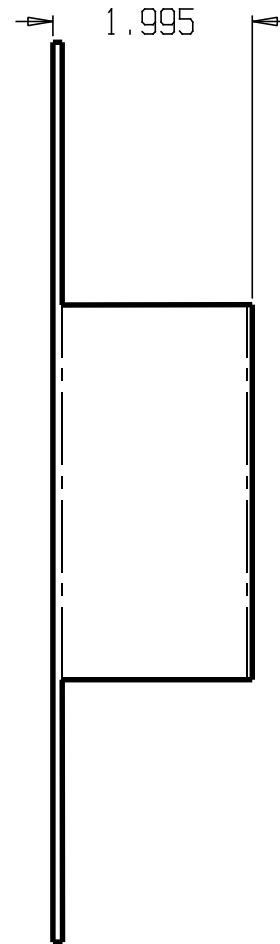
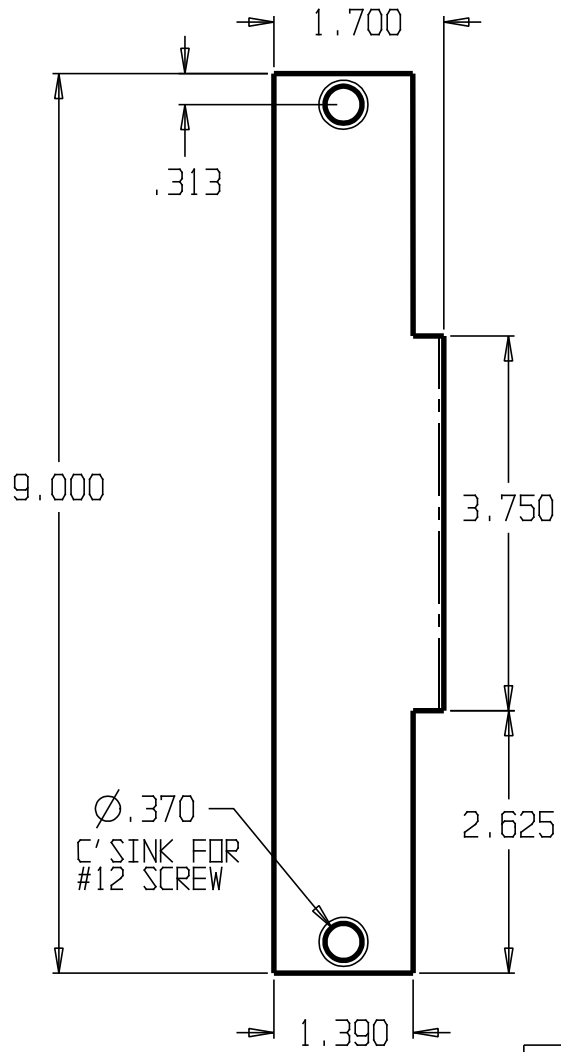

DON-JO MFG. INC.

| | | | | |
|----------|-------|--------------|----------|-------|
| DESIGNER | SIZE | DATE: | PART NO. | REV |
| | A | 4/30/04 | AF-29L | |
| APPROVED | SCALE | RELEASE DATE | WEIGHT | SHEET |
| | | | | |

| REVISIONS | | | |
|-----------|-----|---------------|------------|
| ZONE | REV | FINISHES: | GALUGE: |
| | | 605,613 & 630 | 1/8" THICK |

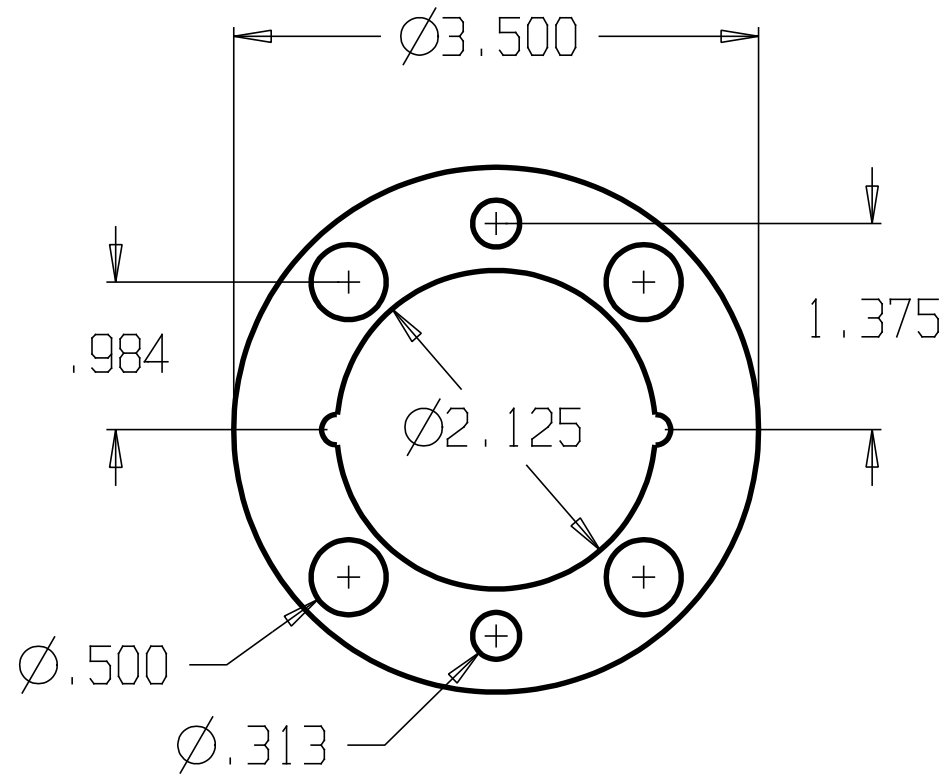

STOCK: 1/8" THICK

| | | | | | | | |
|------------------|--|-------|--------------|--------|-------|----------|-----|
| DON-JO MFG. INC. | | | | SIZE | DATE: | PART NO. | REV |
| DESIGNER | | A | 5/3/04 | AR-335 | | | |
| APPROVED | | SCALE | RELEASE DATE | WEIGHT | SHEET | | |

| REVISIONS | | |
|-----------|-----|---------------|
| ZONE | REV | FINISHES: |
| | | 605,613 & 630 |
| | | GALUGE: |
| | | 1/8" THICK |

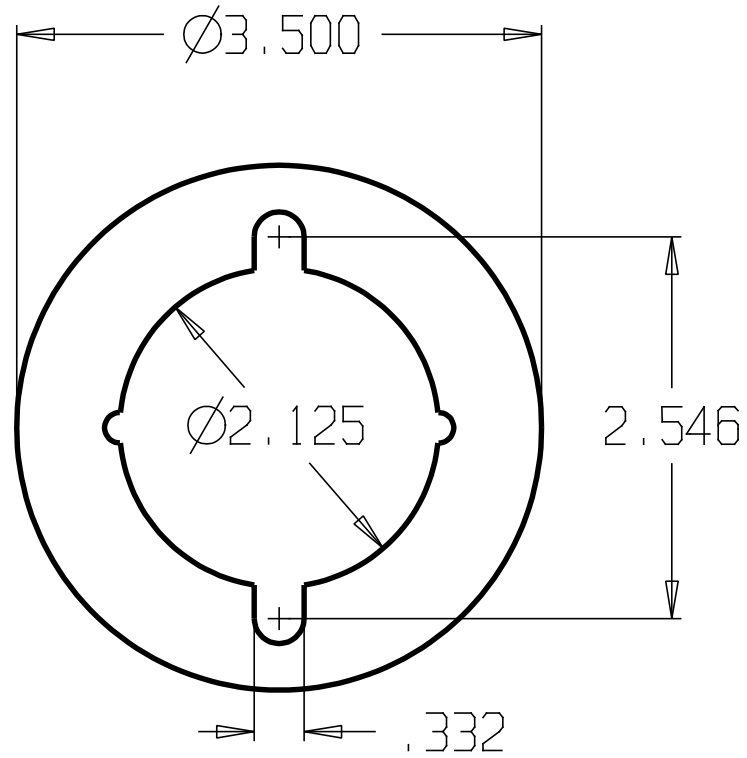

DON-JO MFG. INC.

| | | | | |
|----------|-------|--------------|----------|-------|
| DESIGNER | SIZE | DATE: | PART NO. | REV |
| | A | 5/3/04 | AR-9K | |
| APPROVED | SCALE | RELEASE DATE | WEIGHT | SHEET |
| | | | | |

| REVISIONS | | |
|-----------|-----|-------------|
| ZONE | REV | FINISHES: |
| | | PB, PC & SL |
| | | GALIGE: |
| | | 16ga. .060 |

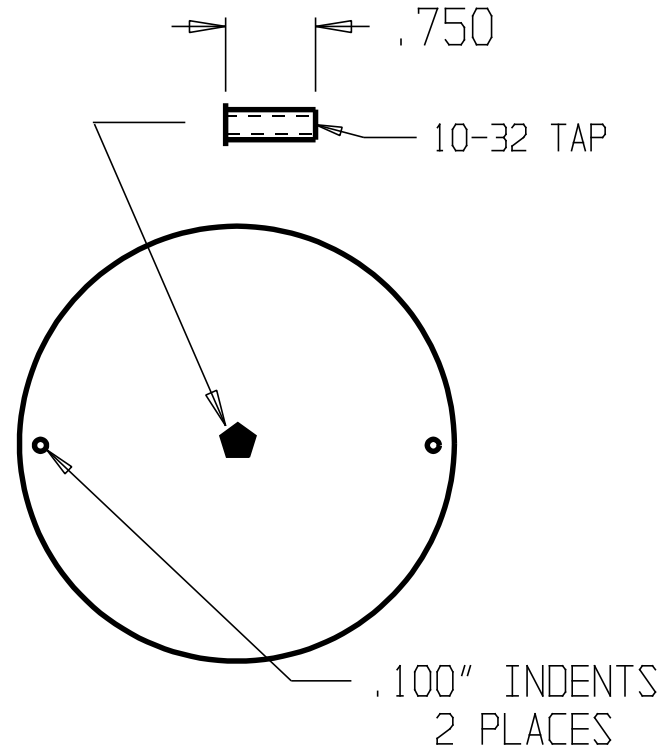
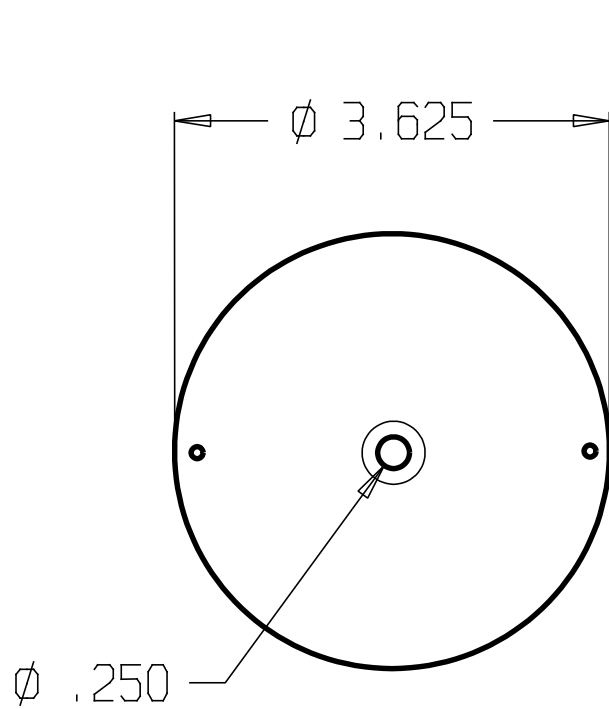

| | | | | | | | |
|------------------|--|-------|--------------|--------|-------|----------|-----|
| DON-JO MFG. INC. | | | | SIZE | DATE: | PART NO. | REV |
| DESIGNER | | A | 5/3/04 | BF-135 | | | |
| APPROVED | | SCALE | RELEASE DATE | WEIGHT | SHEET | | |

| REVISIONS | | |
|-----------|-----|-------------|
| ZONE | REV | FINISHES: |
| | | BP, PC & SL |
| | | GALIGE: |
| | | 16ga. .060 |

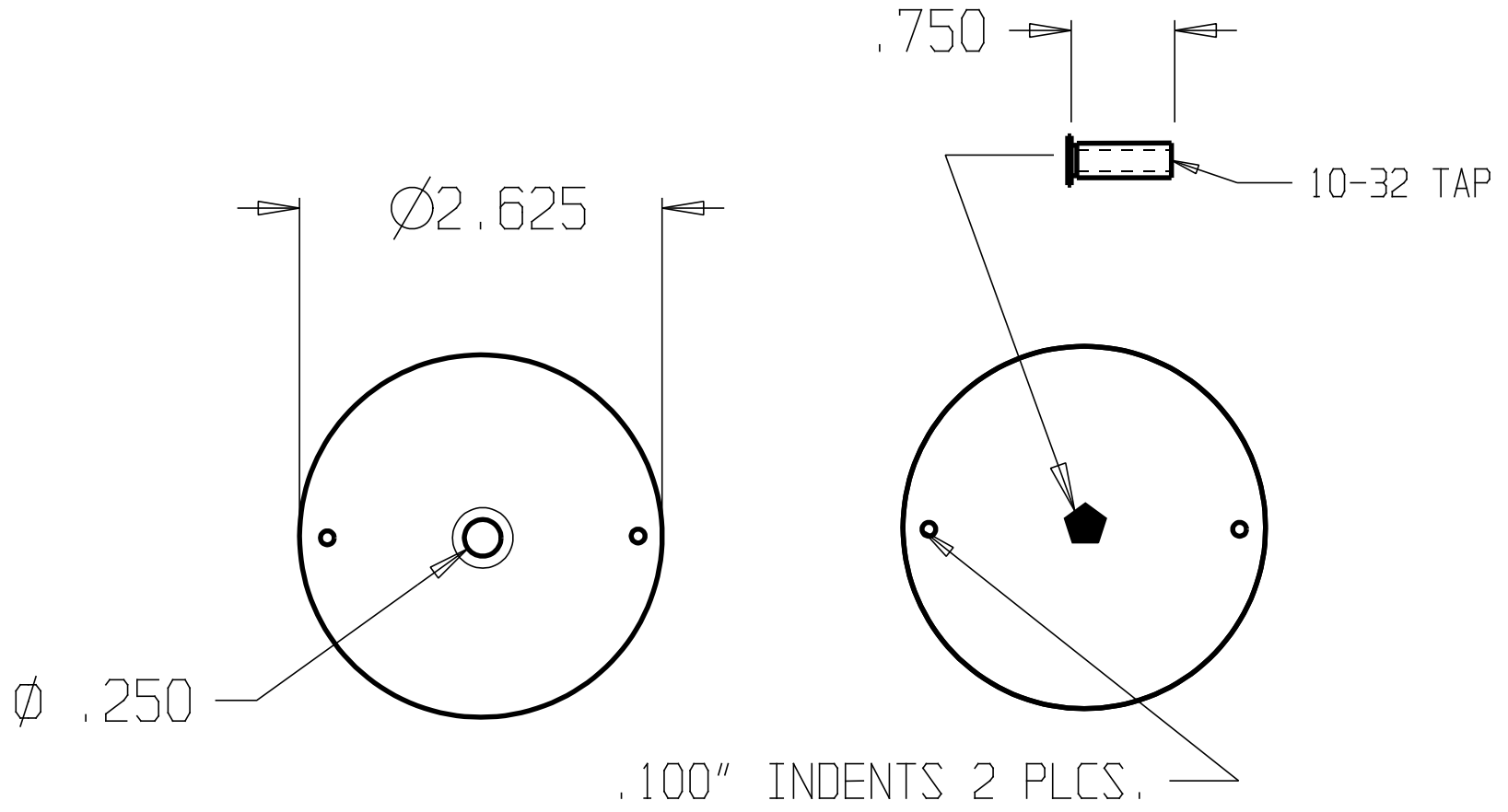

DON-JO MFG. INC.

| | | | | |
|----------|-------|--------------|----------|-------|
| DESIGNER | SIZE | DATE: | PART NO. | REV |
| | A | 5/3/04 | BF-161 | |
| APPROVED | SCALE | RELEASE DATE | WEIGHT | SHEET |
| | | | | |

| REVISIONS | | | |
|-----------|-----|-------------|------------|
| ZONE | REV | FINISHES: | GAUGE: |
| | | BP, PC & SL | 16ga. .060 |

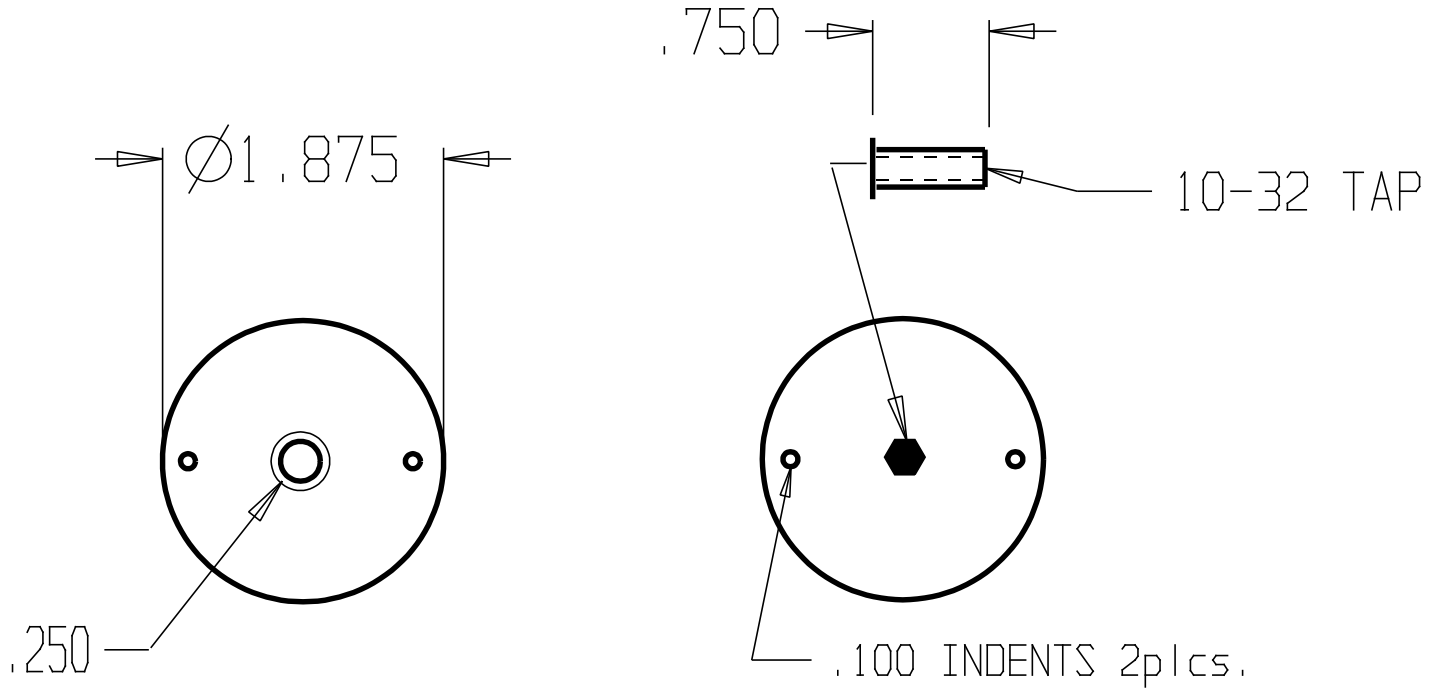

DON-JO MFG. INC.

| | | | | |
|----------|-------|--------------|----------|-------|
| DESIGNER | SIZE | DATE: | PART NO. | REV |
| | A | 5/3/04 | BF-178 | |
| APPROVED | SCALE | RELEASE DATE | WEIGHT | SHEET |
| | | | | |

REVISIONS

| | | | | | |
|------|-----|-----------|----|--------|------------|
| ZONE | REV | FINISHES: | PC | GAUGE: | 13ga. .095 |
|------|-----|-----------|----|--------|------------|

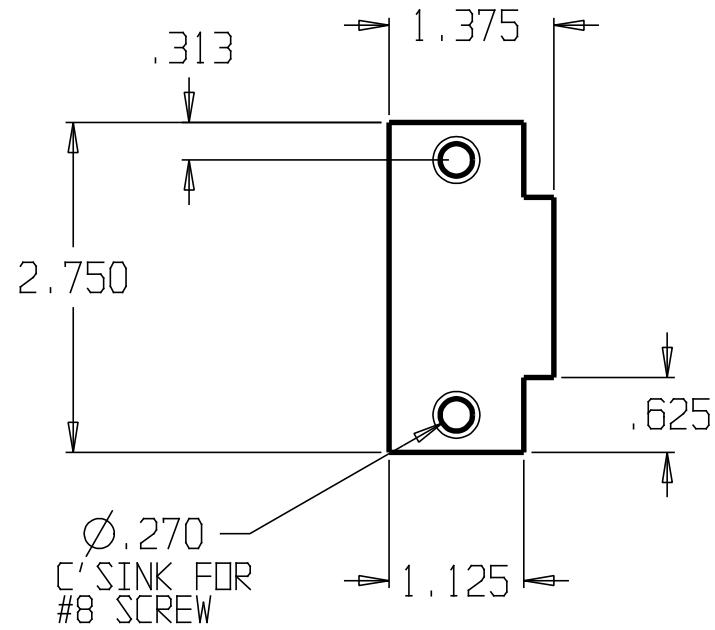

DON-JO MFG. INC.

| | | | | |
|----------|-------|--------------|----------|-------|
| DESIGNER | SIZE | DATE: | PART NO. | REV |
| | A | 5/4/04 | BTS-160 | |
| APPROVED | SCALE | RELEASE DATE | WEIGHT | SHEET |

| REVISIONS | | | |
|-----------|-----|-----------|--------|
| ZONE | REV | FINISHES: | GAUGE: |
| | | BLUE | |

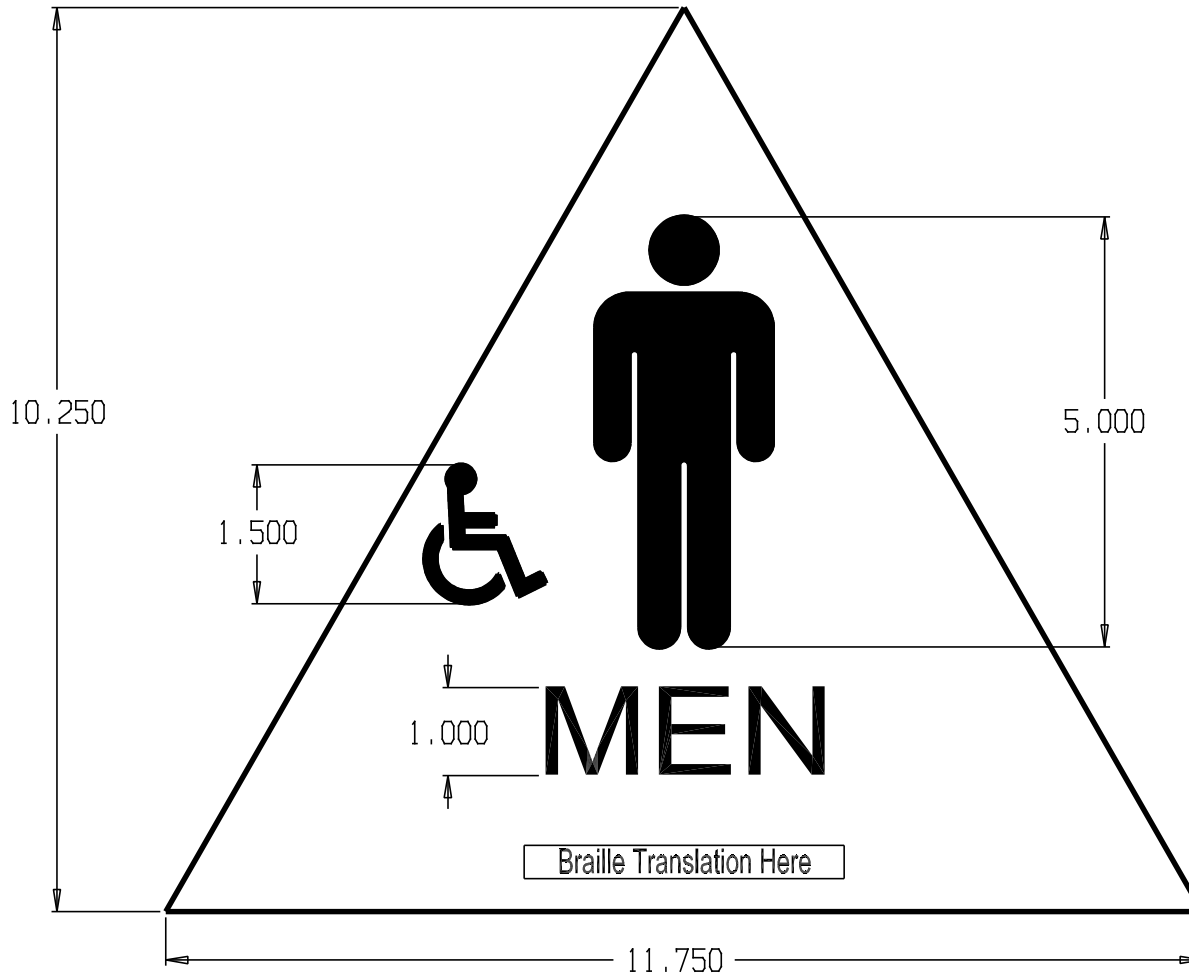

DON-JO MFG. INC.

| | | | | | | | | | |
|----------|--|-------|---|--------------|--------|----------|-------|-------|--|
| DESIGNER | | SIZE | A | DATE: | 5/4/04 | PART NO. | CHS-4 | REV | |
| APPROVED | | SCALE | | RELEASE DATE | | WEIGHT | | SHEET | |

| REVISIONS | | | |
|-----------|-----|-----------|--------|
| ZONE | REV | FINISHES: | GAUGE: |
| | | BLUE | |

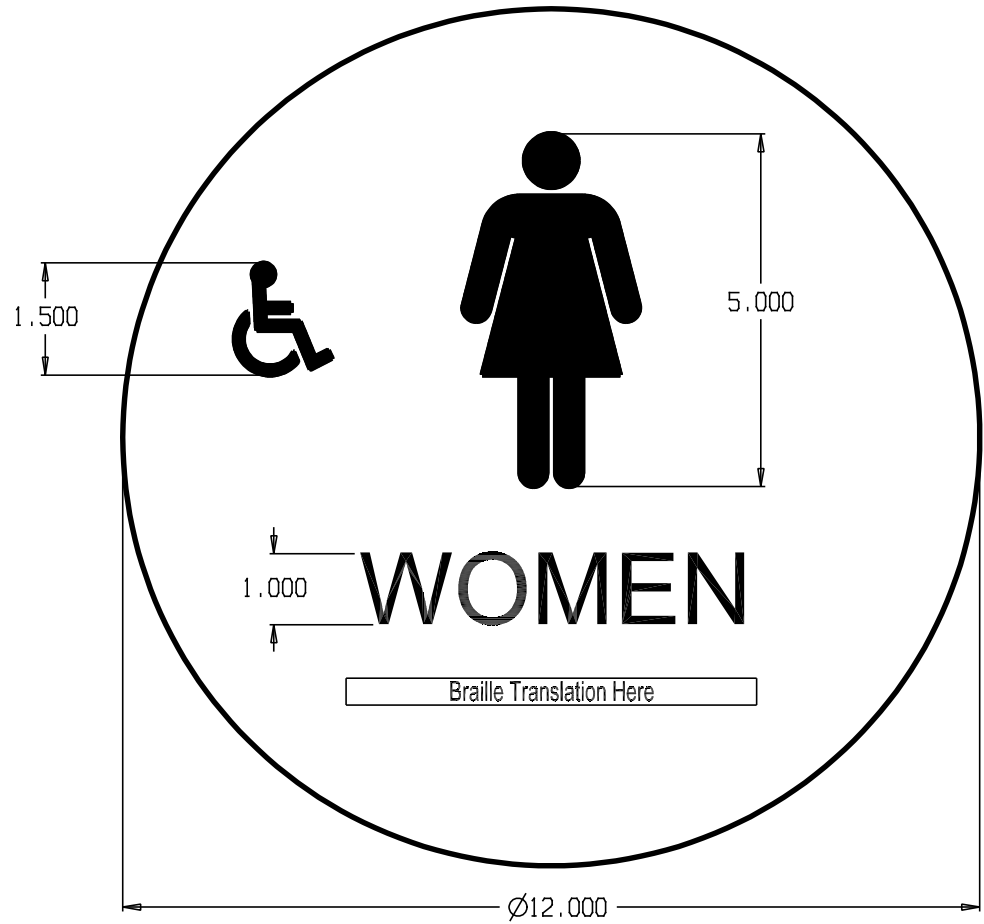

DON-JO MFG. INC.

| | | | | | |
|----------|--|-----------|-----------------|-------------------|-------|
| DESIGNER | | SIZE A | DATE: 5/4/04 | PART NO. CHS-2 | REV |
| APPROVED | | SCALE | RELEASE DATE | WEIGHT | SHEET |

| REVISIONS | | | |
|-----------|-----|-----------|--------|
| ZONE | REV | FINISHES: | GAUGE: |
| | | BLUE | |

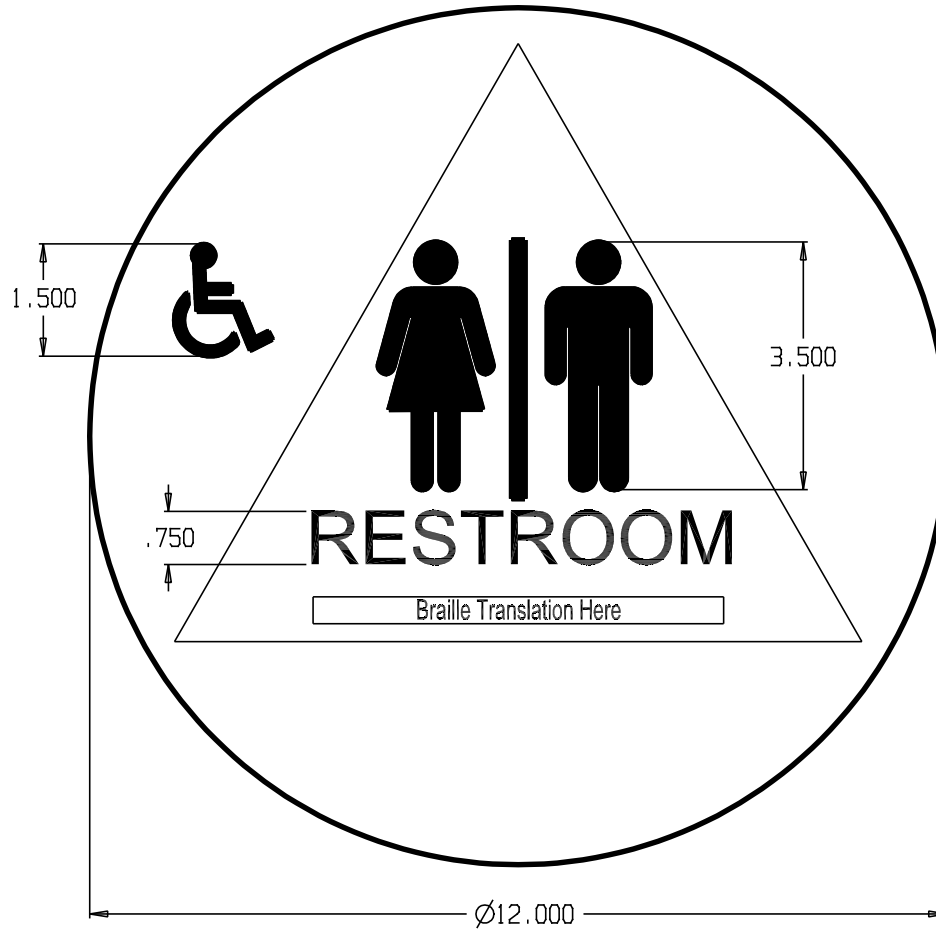

DON-JO MFG. INC.

DESIGNER
APPROVED

| | | | |
|-----------|-----------------|-------------------|-------|
| SIZE A | DATE: 5/4/04 | PART NO. CHS-3 | REV |
| SCALE | RELEASE DATE | WEIGHT | SHEET |

| REVISIONS | | |
|-----------|-----|-------------|
| ZONE | REV | FINISHES: |
| | | BP, PC & SL |
| | | GALIGE: |
| | | 16ga. .060 |

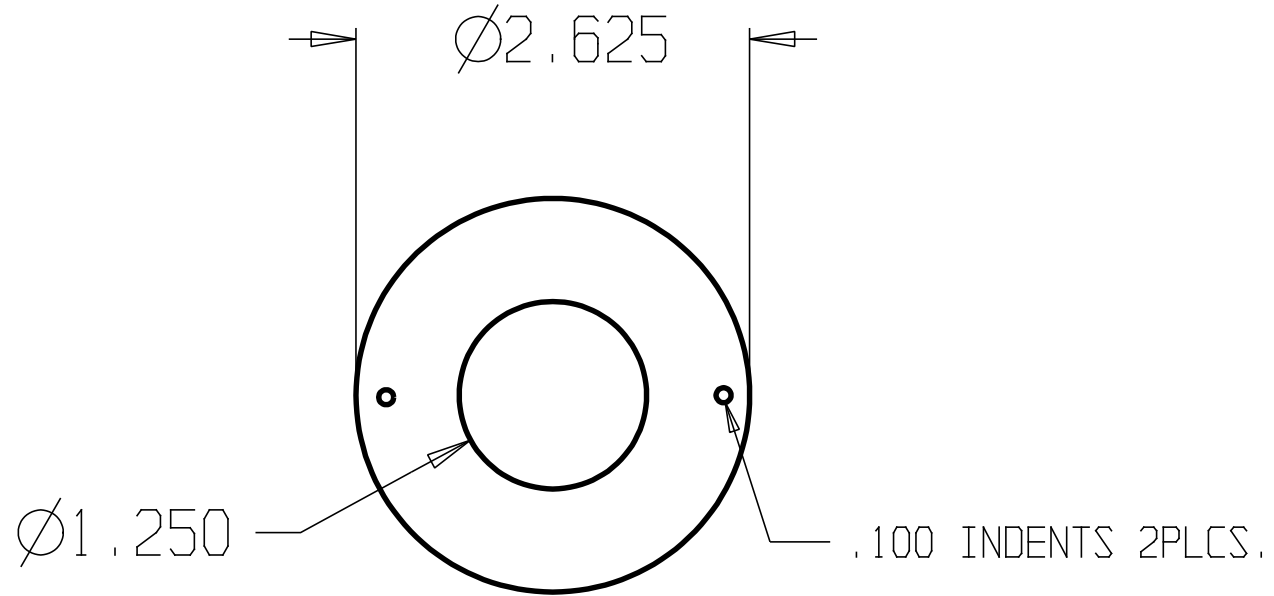

DON-JO MFG. INC.

| | | | | |
|----------|-------|--------------|----------|-------|
| DESIGNER | SIZE | DATE: | PART NO. | REV |
| | A | 5/3/04 | CP-258 | |
| APPROVED | SCALE | RELEASE DATE | WEIGHT | SHEET |
| | | | | |

DWG NO. SH REV

REVISIONS

| ZONE | REV | FINISHES: | GAUGE: |
|------|-----|-----------|------------|
| | | RAW STEEL | 16ga. .060 |

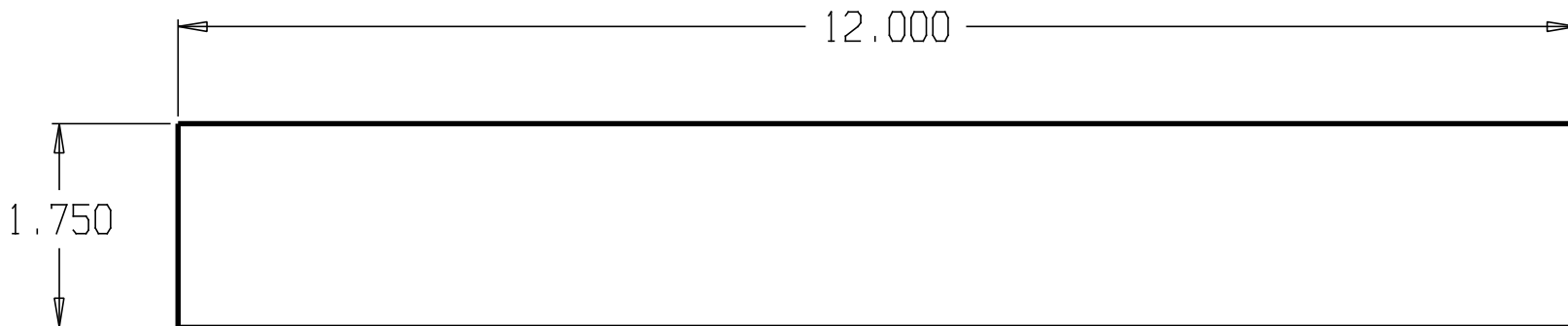

DON-JO MFG. INC.

| | | | | |
|----------|-------|--------------|----------|-------|
| DESIGNER | SIZE | DATE: | PART NO. | REV |
| | A | 5/6/04 | CR-060 | |
| APPROVED | SCALE | RELEASE DATE | WEIGHT | SHEET |

DWG NO. SH REV

REVISIONS

| ZONE | REV | FINISHES: | GAUGE: |
|------|-----|-----------|------------|
| | | RAW STEEL | 10ga. .134 |

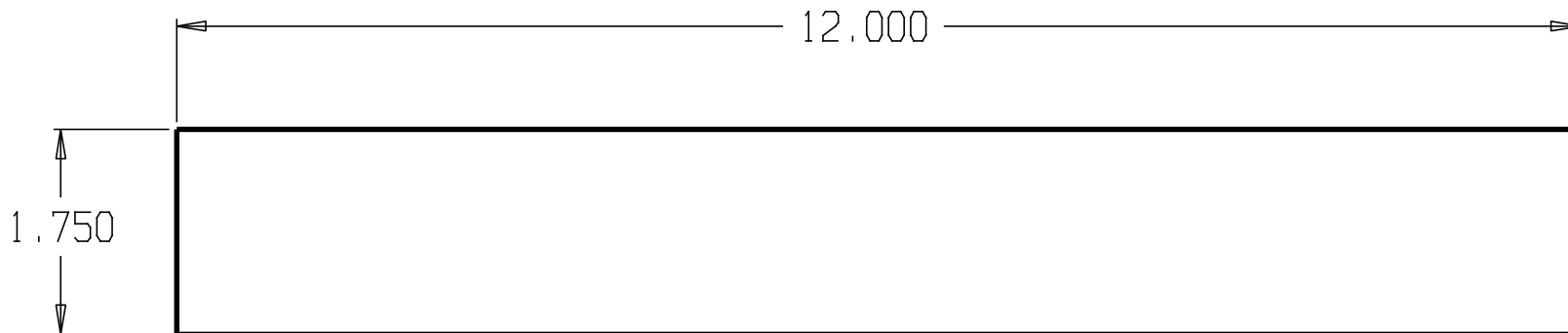

DON-JO MFG. INC.

| | | | | |
|----------|-------|--------------|----------|-------|
| DESIGNER | SIZE | DATE: | PART NO. | REV |
| | A | 5/6/04 | CR-125 | |
| APPROVED | SCALE | RELEASE DATE | WEIGHT | SHEET |
| | | | | |

| REVISIONS | | | |
|-----------|-----|-----------|------------|
| ZONE | REV | FINISHES: | GAUGE: |
| | | RAW STEEL | 12ga. .104 |

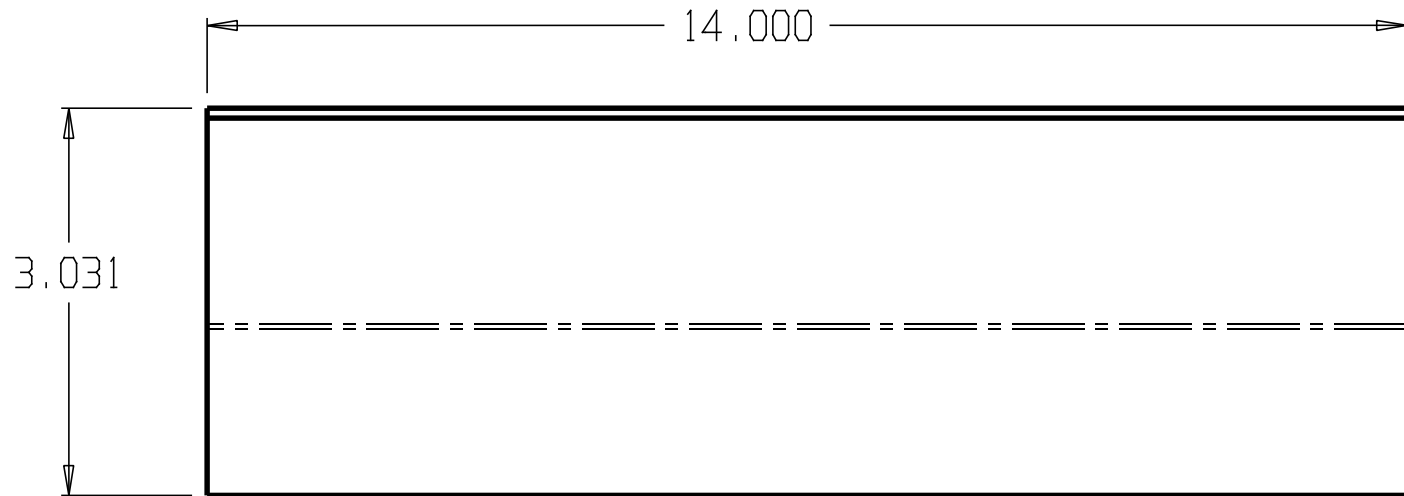
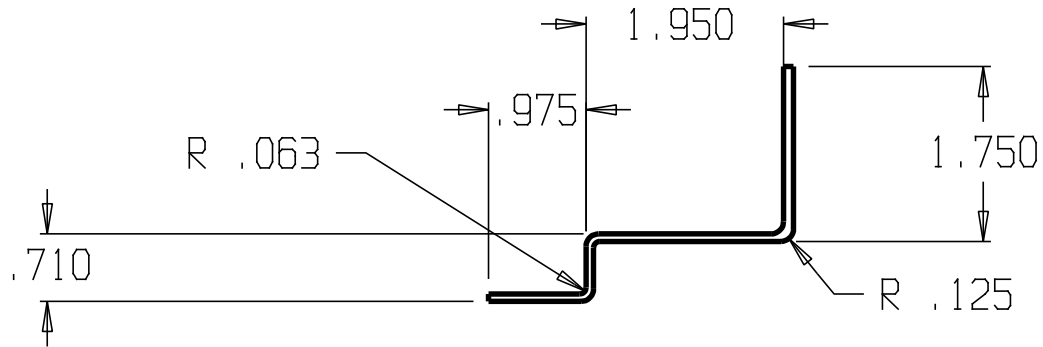

DON-JO MFG. INC.

| | | | | |
|----------|-------|--------------|----------|-------|
| DESIGNER | SIZE | DATE: | PART NO. | REV |
| | A | 5/6/04 | CR-275 | |
| APPROVED | SCALE | RELEASE DATE | WEIGHT | SHEET |
| | | | | |

| REVISIONS | | | |
|-----------|-----|-----------|------------|
| ZONE | REV | FINISHES: | GAUGE: |
| | | RAW STEEL | 12ga. .104 |

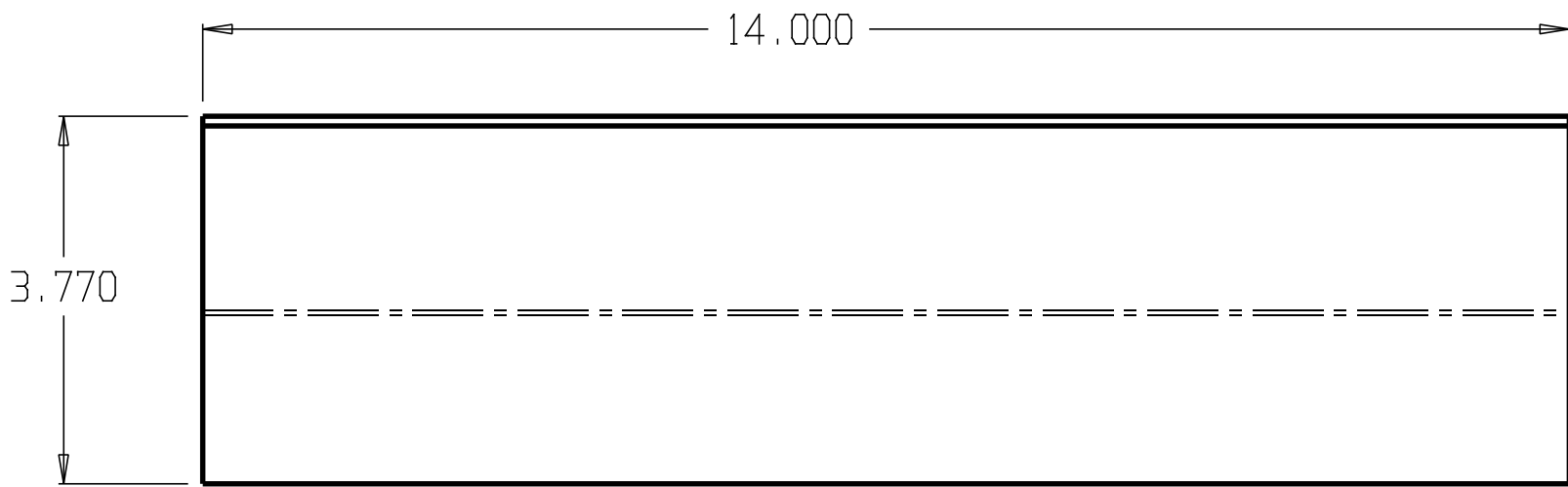
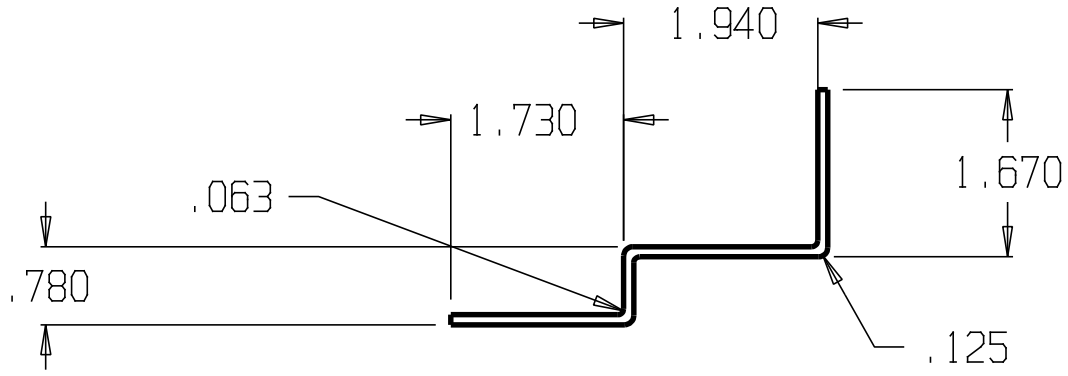

DON-JO MFG. INC.

| | | | | |
|----------|-------|--------------|----------|-------|
| DESIGNER | SIZE | DATE: | PART NO. | REV |
| | A | 5/6/04 | CR-300 | |
| APPROVED | SCALE | RELEASE DATE | WEIGHT | SHEET |

| REVISIONS | | | |
|-----------|-----|-----------|--------|
| ZONE | REV | FINISHES: | GUAGE: |
| | | SL | 1/4" |

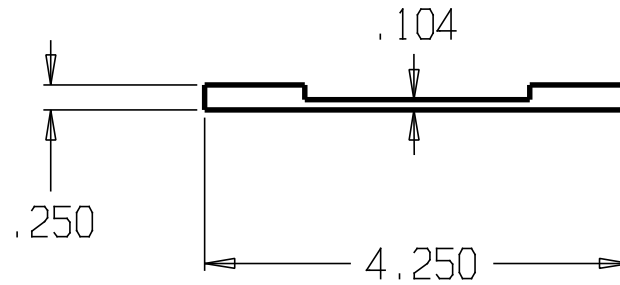
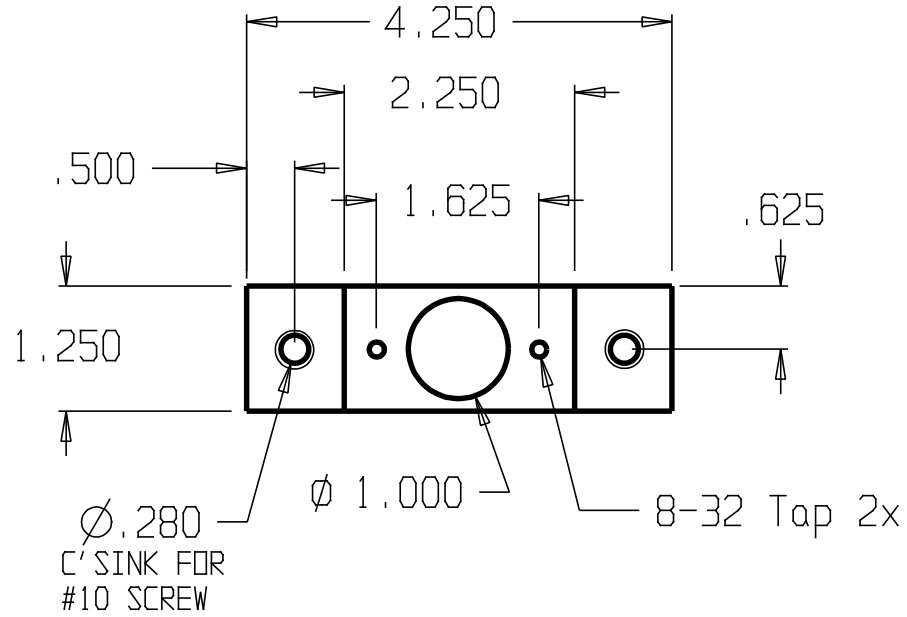

DON-JO MFG. INC.

DESIGNER
APPROVED

SIZE: A
DATE: 5/7/04

PART NO.: CV-2414
REV

SCALE: RELEASE DATE: WEIGHT: SHEET:

| REVISIONS | | | |
|-----------|-----|-----------|---------|
| ZONE | REV | FINISHES: | GALUGE: |
| | | PC | 1/4" |

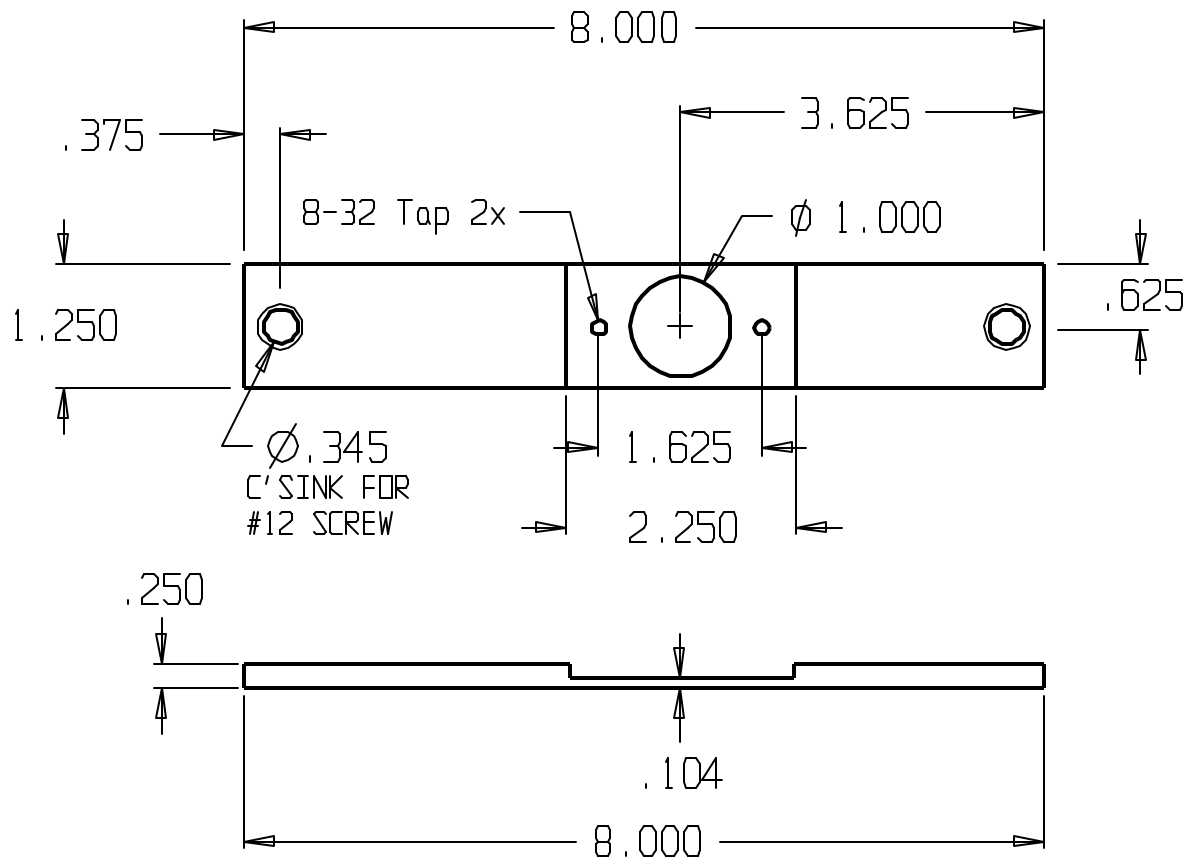

DON-JO MFG. INC.

| | | | | |
|----------|-------|--------------|----------|-------|
| DESIGNER | SIZE | DATE | PART NO. | REV |
| | A | 5/7/04 | CV-86 | |
| APPROVED | SCALE | RELEASE DATE | WEIGHT | SHEET |

| REVISIONS | | | |
|-----------|-----|-----------|--------|
| ZONE | REV | FINISHES: | GUAGE: |
| | | BP & SL | 1/4" |

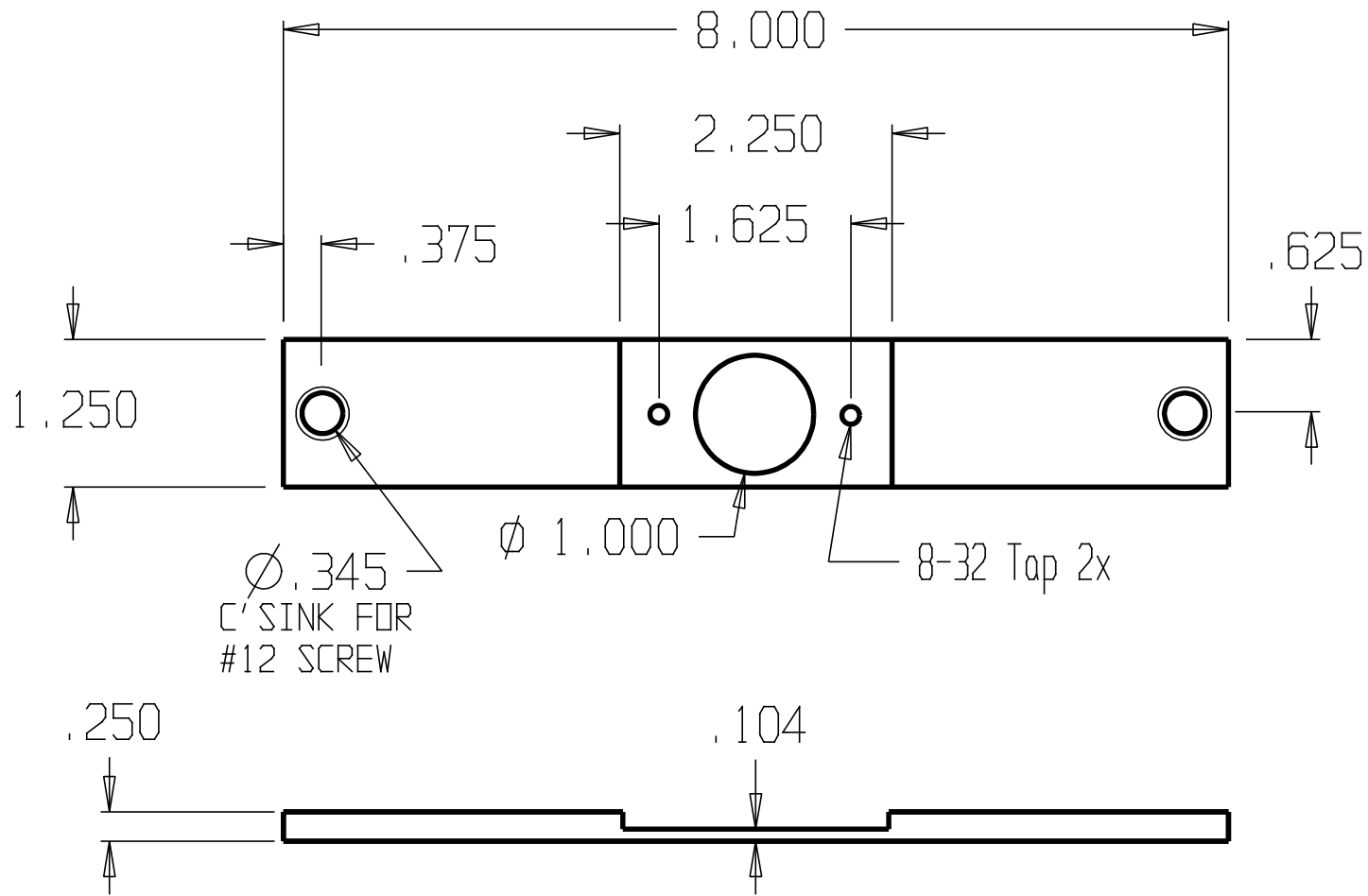

| | | | | | | | |
|------------------|--|-------|--------------|--------|-------|----------|-----|
| DON-JO MFG. INC. | | | | SIZE | DATE: | PART NO. | REV |
| DESIGNER | | A | 5/7/04 | CV-86C | | | |
| APPROVED | | SCALE | RELEASE DATE | WEIGHT | SHEET | | |

| REVISIONS | | |
|-----------|-----|-----------|
| ZONE | REV | FINISHES: |
| | | PC |
| | | GUAGE: |
| | | 1/4" |

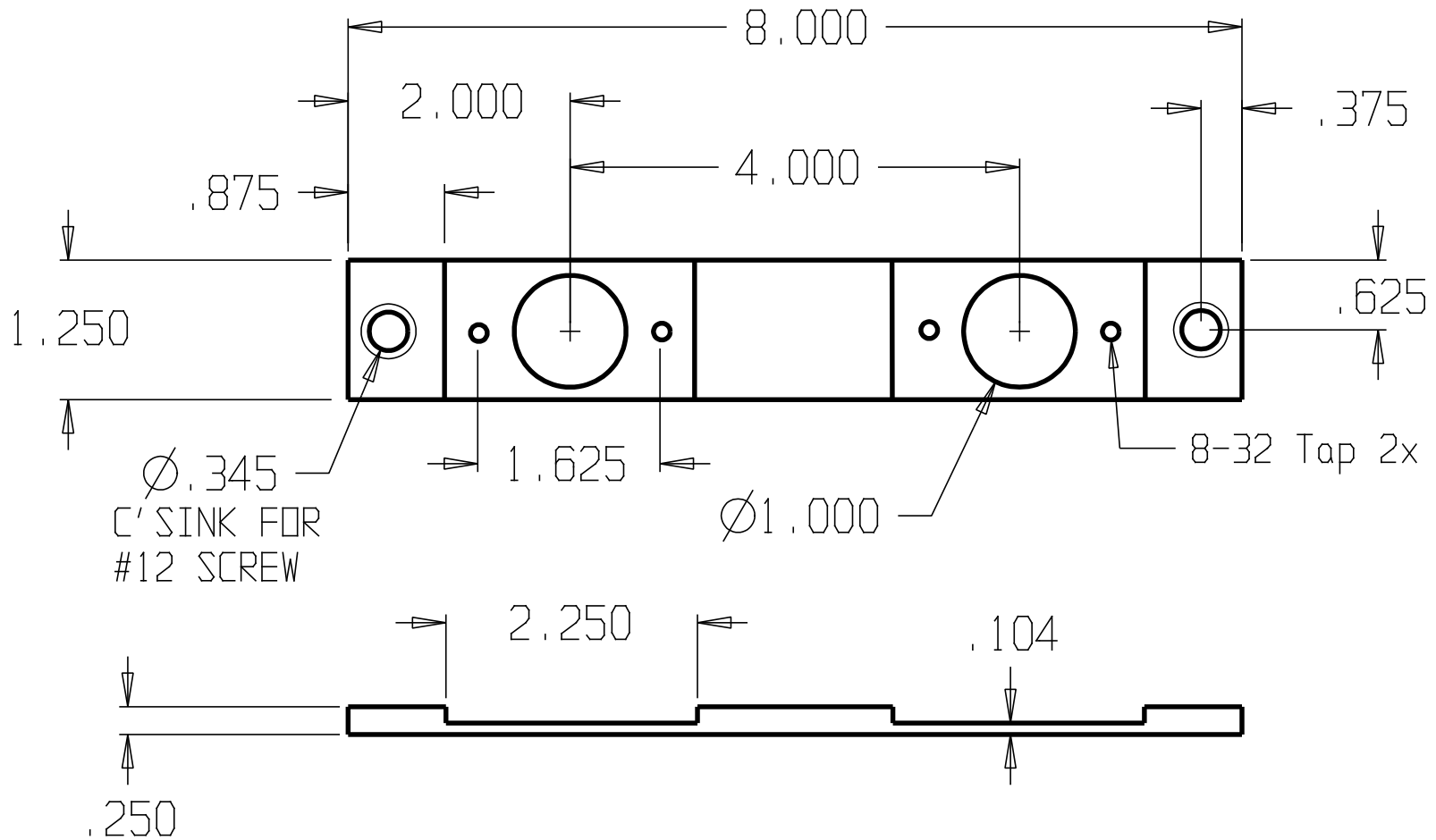

| | | | | | | | |
|------------------|--|-------|--------------|---------|-------|----------|-----|
| DON-JO MFG. INC. | | | | SIZE | DATE: | PART NO. | REV |
| DESIGNER | | A | 5/7/04 | CV-8624 | | | |
| APPROVED | | SCALE | RELEASE DATE | WEIGHT | SHEET | | |

| REVISIONS | | |
|-----------|-----|--------------------|
| ZONE | REV | FINISHES: |
| | | SILVER COAT |
| | | GAUGE: |

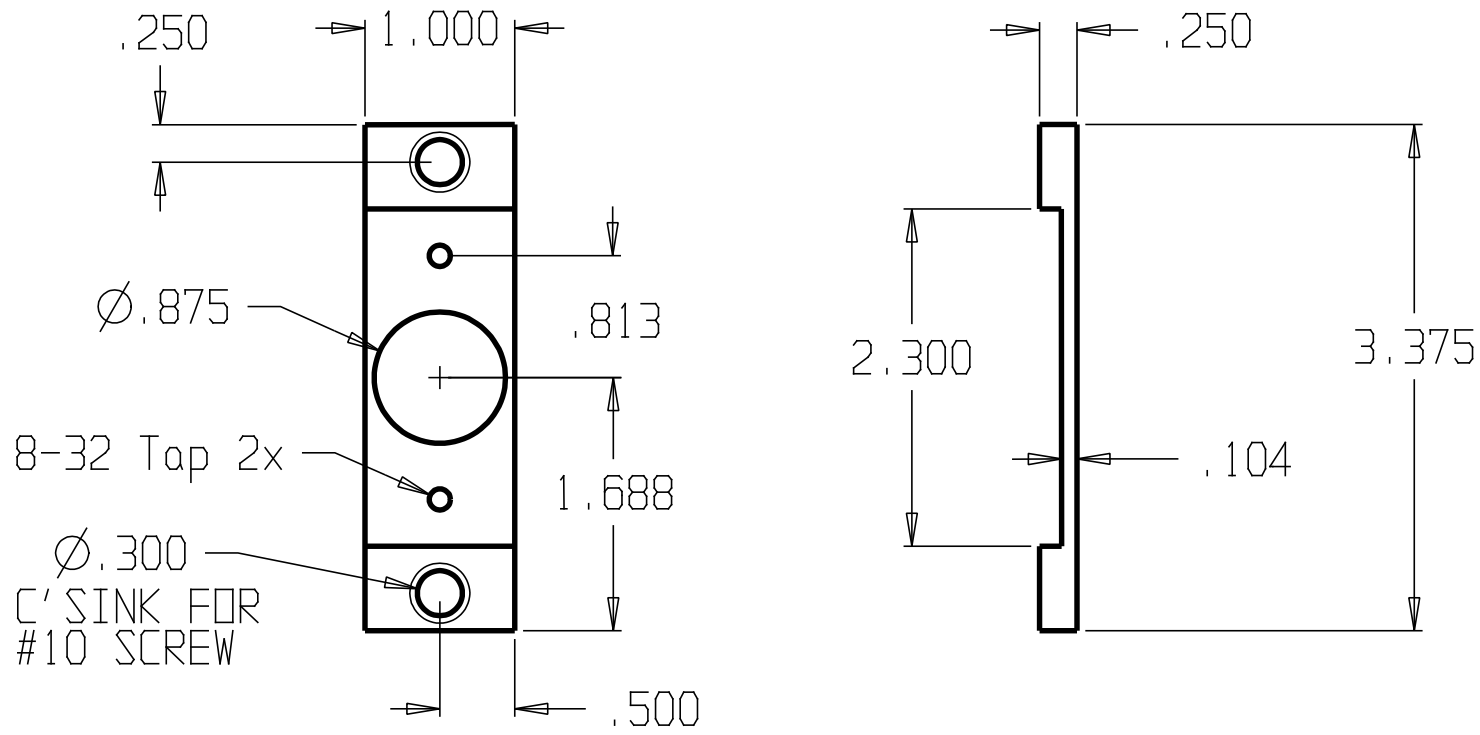

DON-JO MFG. INC.

| | |
|----------|--|
| DESIGNER | |
| APPROVED | |

| | | | |
|-------|--------------|----------|-------|
| SIZE | DATE: | PART NO. | REV |
| A | 12/20/05 | CVRL | |
| SCALE | RELEASE DATE | WEIGHT | SHEET |

| REVISIONS | | |
|-----------|-----|-------------|
| ZONE | REV | FINISHES: |
| | | PC |
| | | GUAGE: 1/4" |

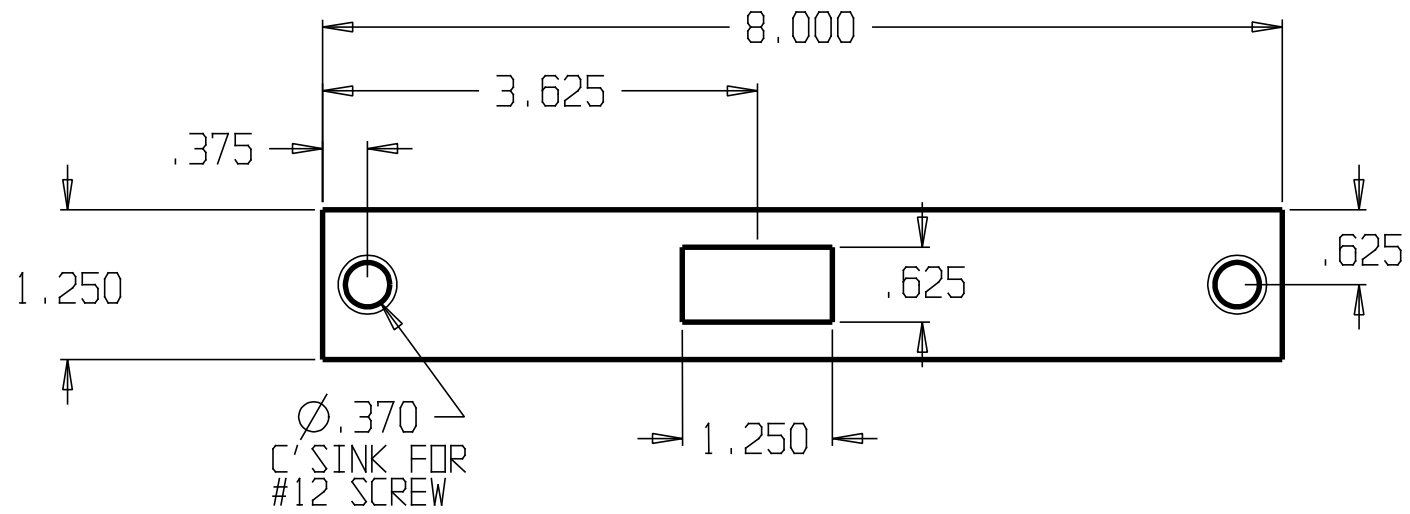

| | | | | | | | |
|------------------|--|-------|--------------|---------|-------|----------|-----|
| DON-JO MFG. INC. | | | | SIZE | DATE: | PART NO. | REV |
| DESIGNER | | A | 5/7/04 | DBS-386 | | | |
| APPROVED | | SCALE | RELEASE DATE | WEIGHT | SHEET | | |

DWG NO. SH REV

REVISIONS

| ZONE | REV | FINISHES: | GUAGE: |
|------|-----|-----------|------------|
| | | RAW STEEL | 25ga. .020 |

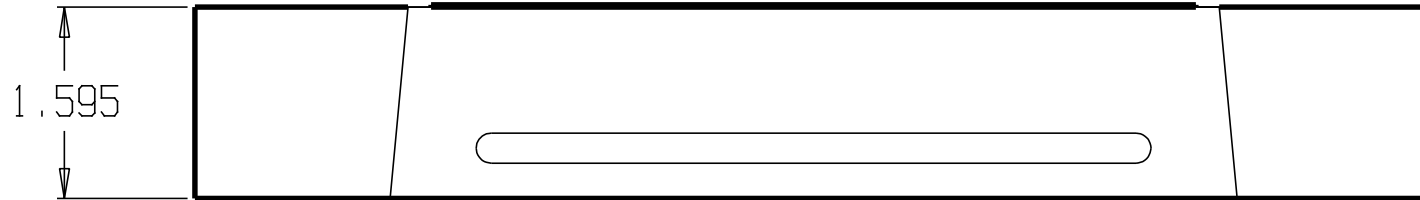
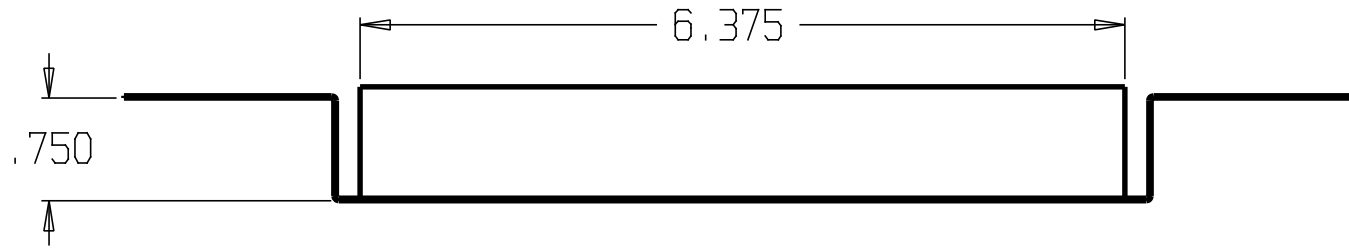

DON-JO MFG. INC.

| | | | | |
|----------|-------|--------------|----------|-------|
| DESIGNER | SIZE | DATE: | PART NO. | REV |
| | A | 5/10/04 | DCB-270 | |
| APPROVED | SCALE | RELEASE DATE | WEIGHT | SHEET |
| | | | | |

| REVISIONS | | |
|-----------|-----|------------|
| ZONE | REV | FINISHES: |
| | | RAW STEEL |
| | | GAUGE: |
| | | 25ga. .020 |

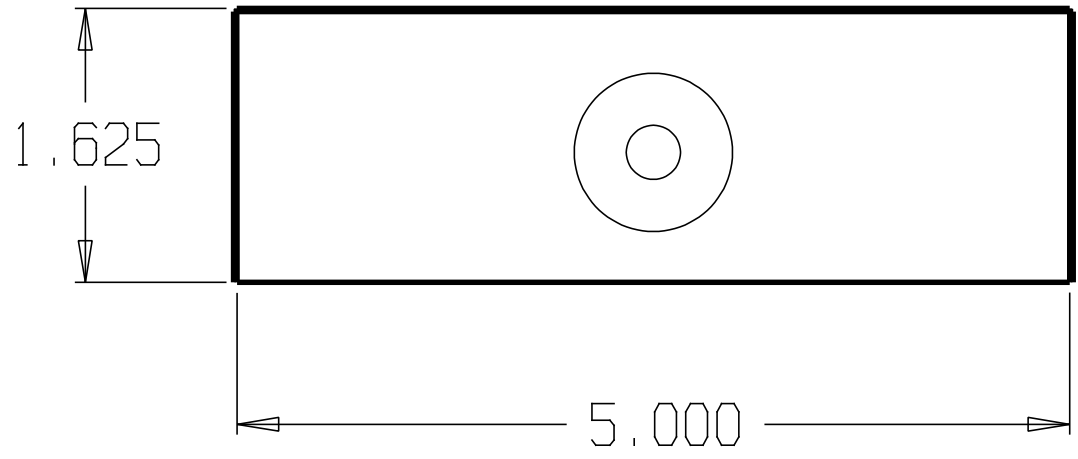
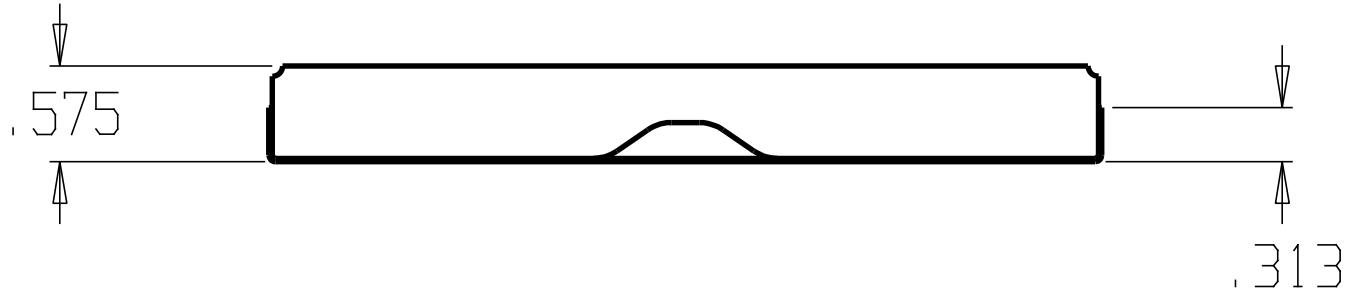

| | | | | | | | |
|------------------|--|-------|--------------|---------|-------|----------|-----|
| DON-JO MFG. INC. | | | | SIZE | DATE: | PART NO. | REV |
| DESIGNER | | A | 5/10/04 | DCB-280 | | | |
| APPROVED | | SCALE | RELEASE DATE | WEIGHT | SHEET | | |

| REVISIONS | | | |
|-----------|-----|-----------|------------|
| ZONE | REV | FINISHES: | GUAGE: |
| | | RAW STEEL | 16ga. .060 |

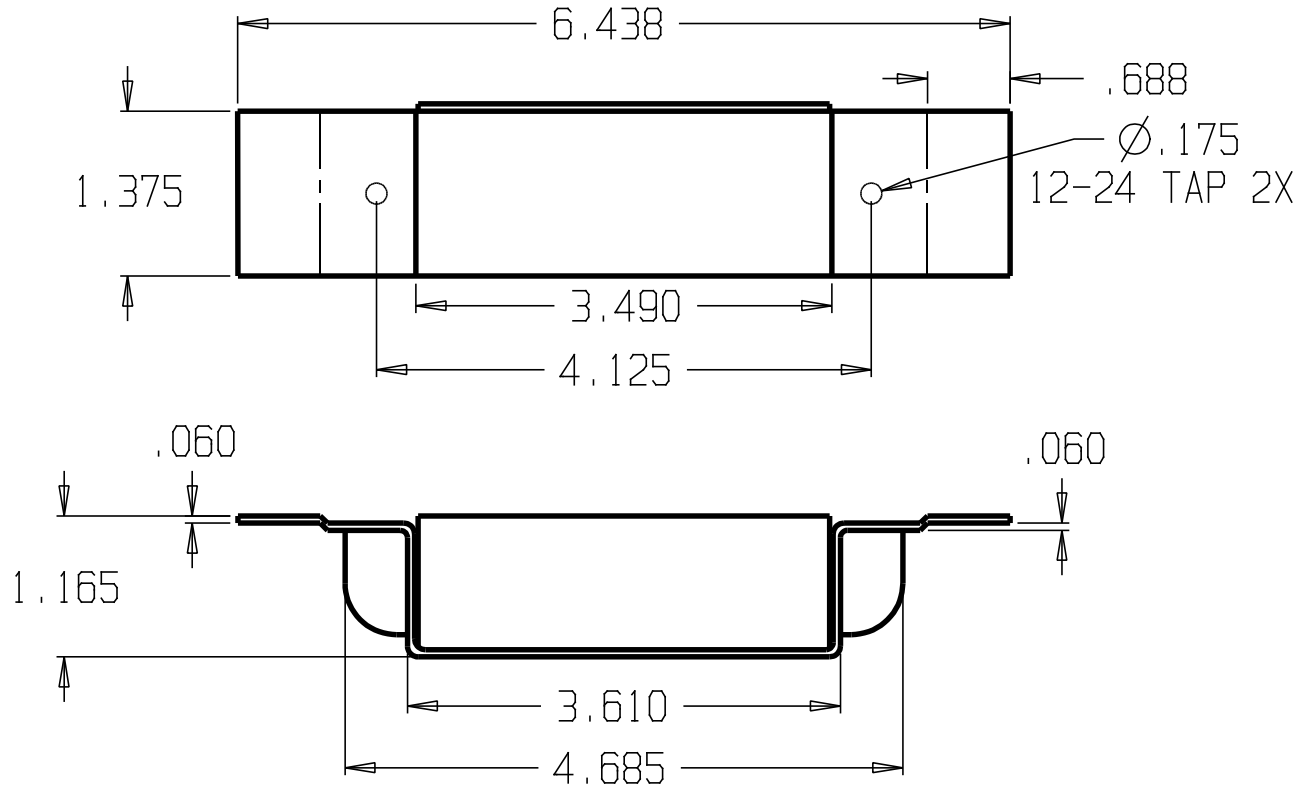

DON-JO MFG. INC.

| | | | | |
|----------|-------|--------------|---------|-------|
| DESIGNER | SIZE | DATE: | PART NO | REV |
| | A | 4/19/04 | DCB 340 | |
| APPROVED | SCALE | RELEASE DATE | WEIGHT | SHEET |
| | | | | |

| REVISIONS | | | |
|-----------|-----|-----------|------------|
| ZONE | REV | FINISHES: | GUAGE: |
| | | RAW STEEL | 16ga. .060 |

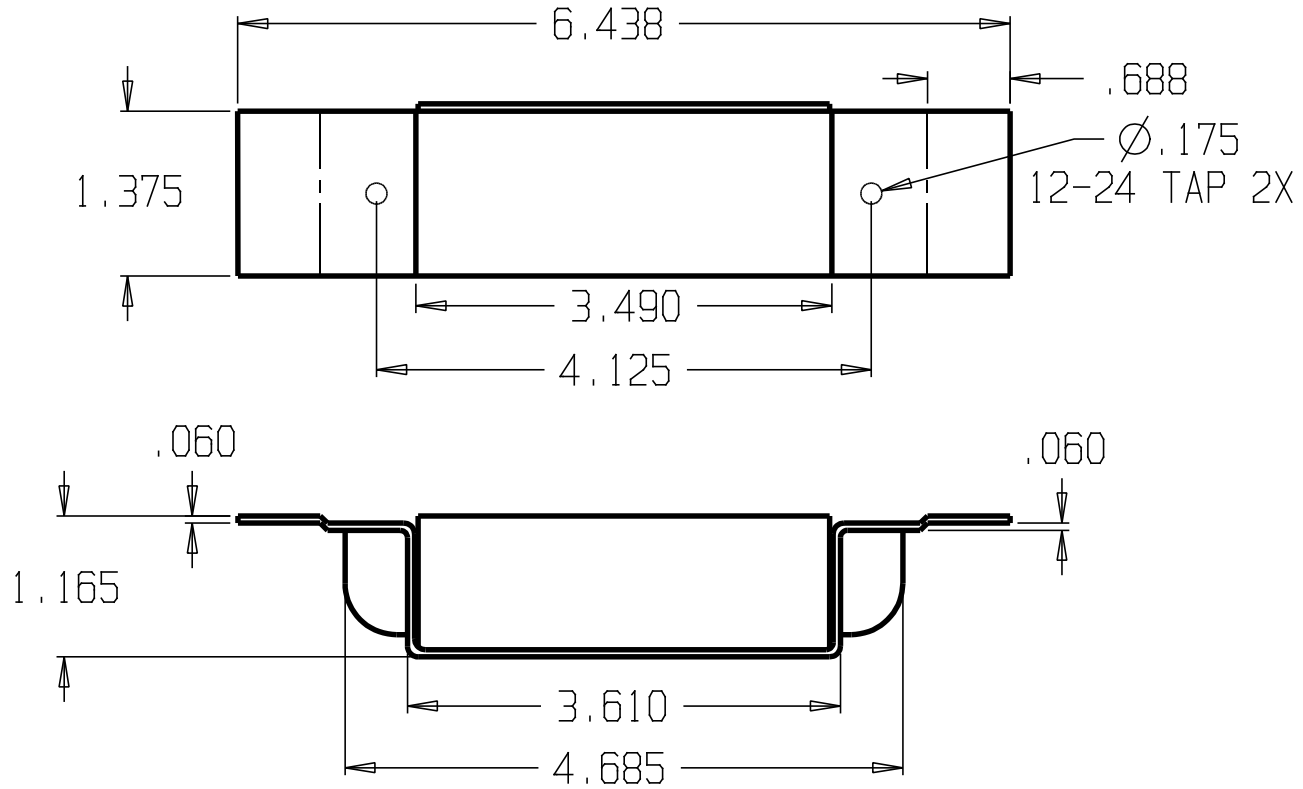

DON-JO MFG. INC.

| | | | | |
|----------|-------|--------------|---------|-------|
| DESIGNER | SIZE | DATE: | PART NO | REV |
| | A | 4/19/04 | DCB 340 | |
| APPROVED | SCALE | RELEASE DATE | WEIGHT | SHEET |
| | | | | |

| REVISIONS | | | |
|-----------|-----|-----------|------------|
| ZONE | REV | FINISHES: | GAUGE: |
| | | BP & PC | 11ga. .119 |

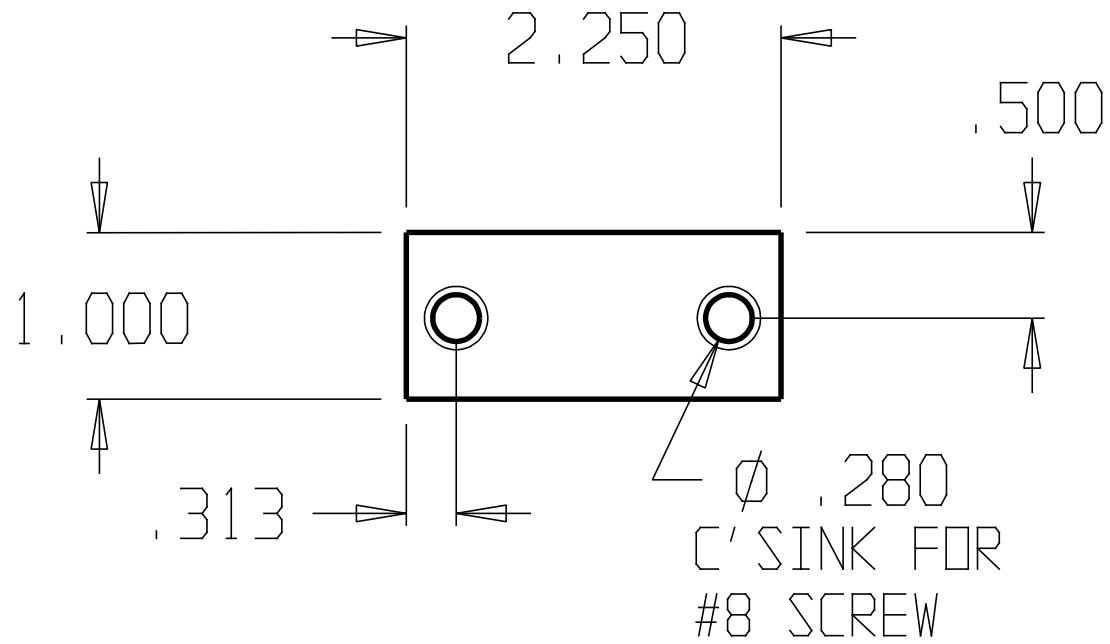

DON-JO MFG. INC.

| | | | | |
|----------|-------|--------------|----------|-------|
| DESIGNER | SIZE | DATE: | PART NO. | REV |
| | A | 5/12/04 | EF-161 | |
| APPROVED | SCALE | RELEASE DATE | WEIGHT | SHEET |
| | | | | |

| REVISIONS | | | |
|-----------|-----|-----------|------------|
| ZONE | REV | FINISHES: | GAUGE: |
| | | BP & PC | 11ga. .119 |

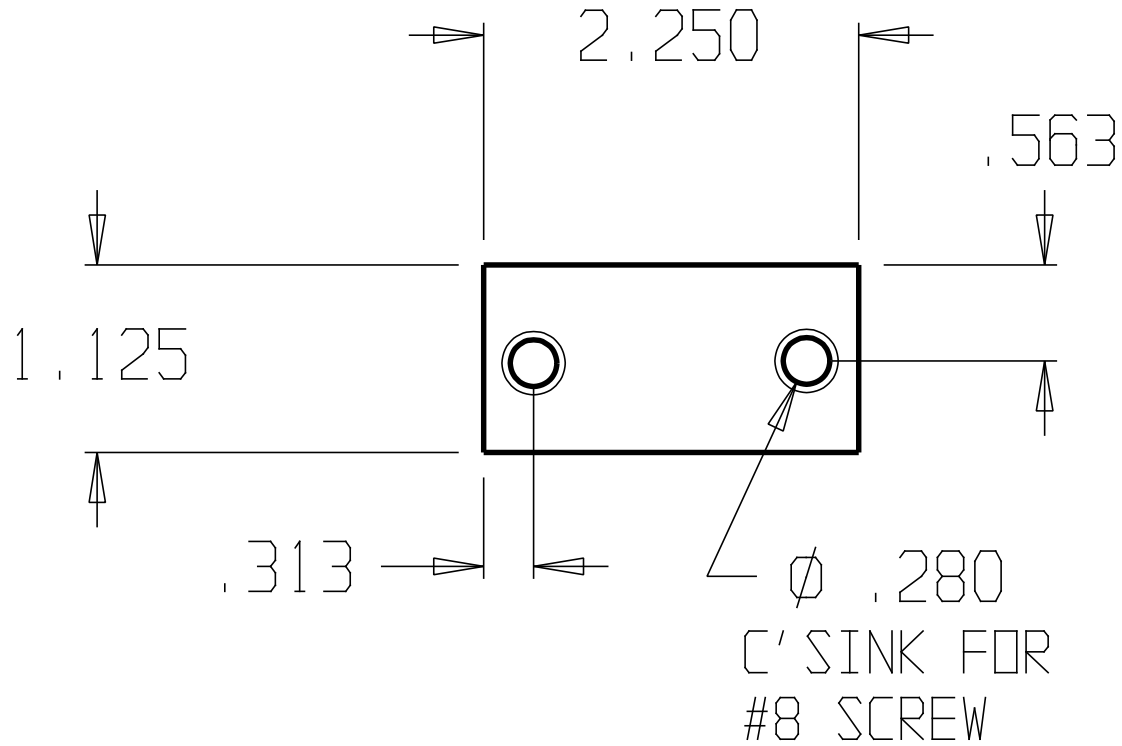

DON-JO MFG. INC.

| | | | | |
|----------|-----------|------------------|--------------------|-------|
| DESIGNER | SIZE A | DATE: 5/12/04 | PART NO. EF-161 | REV |
| APPROVED | SCALE | RELEASE DATE | WEIGHT | SHEET |

| REVISIONS | | | |
|-----------|-----|-----------|------------|
| ZONE | REV | FINISHES: | GAUGE: |
| | | BP & PC | 11ga. .119 |

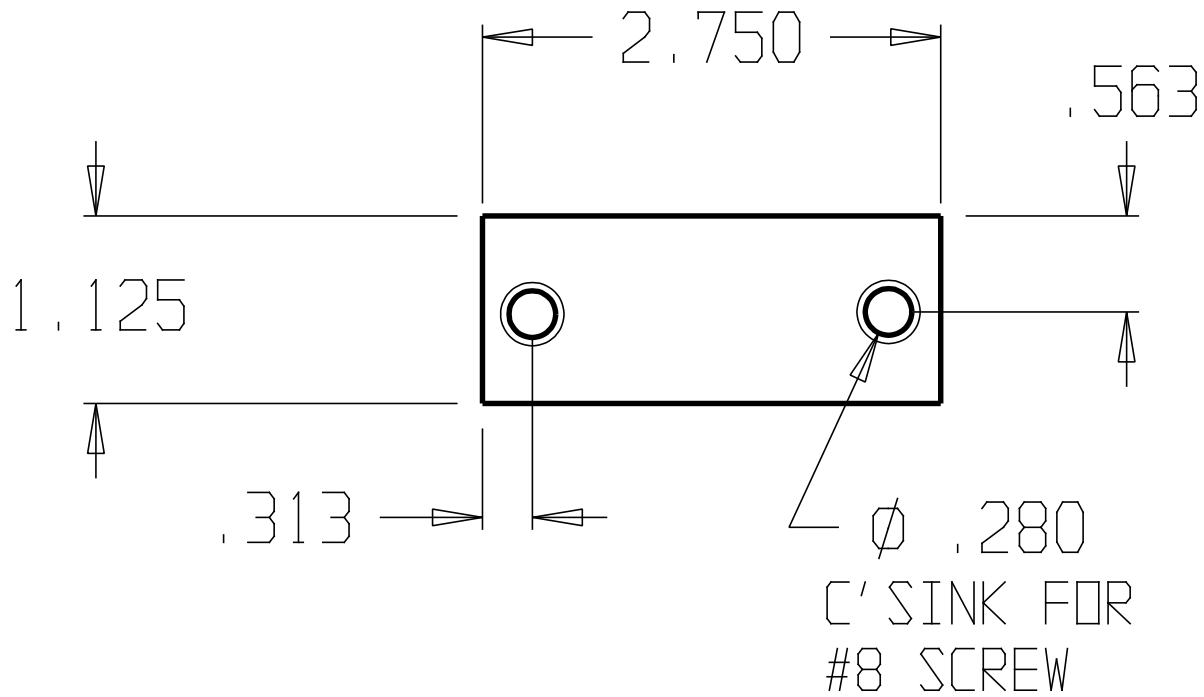

| | | | | | | | |
|------------------|--|-------|--------------|----------|-------|----------|-----|
| DON-JO MFG. INC. | | | | SIZE | DATE: | PART NO. | REV |
| DESIGNER | | A | 5/12/04 | EF-161-S | | | |
| APPROVED | | SCALE | RELEASE DATE | WEIGHT | SHEET | | |

| REVISIONS | | | |
|-----------|-----|-----------|------------|
| ZONE | REV | FINISHES: | GAUGE: |
| | | BP & PC | 16ga. .060 |

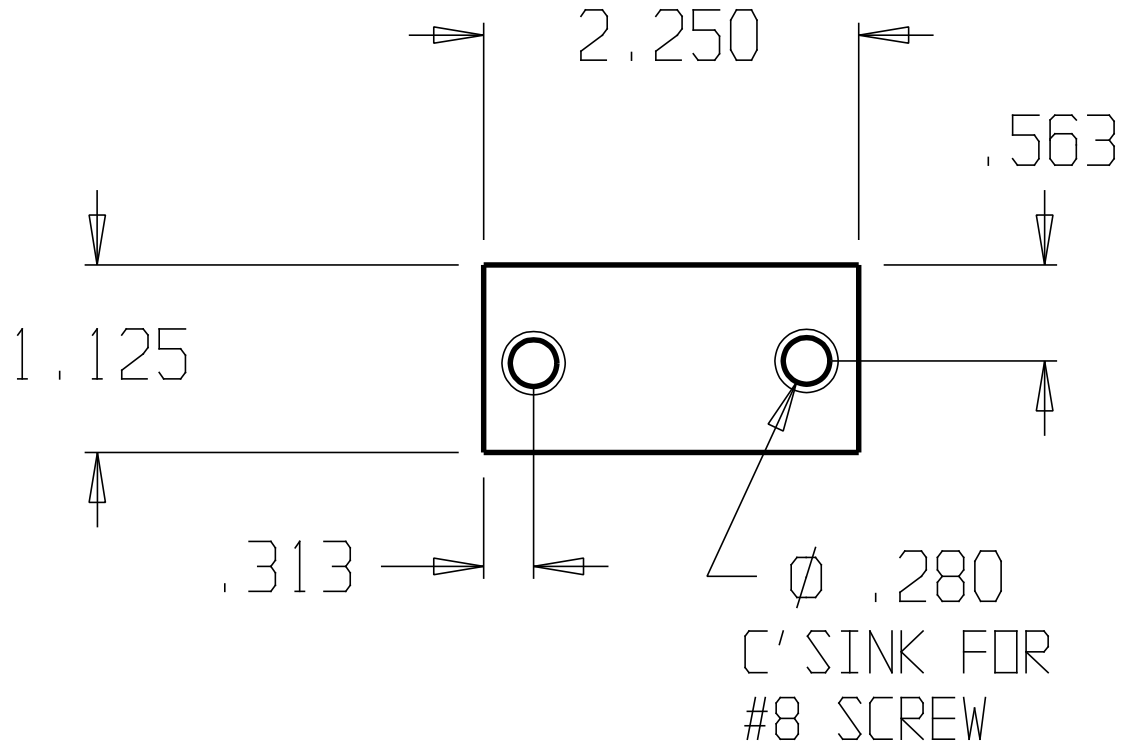

DON-JO MFG. INC.

| | |
|----------|--|
| DESIGNER | |
| APPROVED | |

| | | | |
|-----------|------------------|-----------------------|-------|
| SIZE A | DATE: 5/12/04 | PART NO. EF-161-TG | REV |
| SCALE | RELEASE DATE | WEIGHT | SHEET |

| REVISIONS | | | |
|-----------|-----|-----------|------------|
| ZONE | REV | FINISHES: | GAUGE: |
| | | PC | 11ga. .119 |

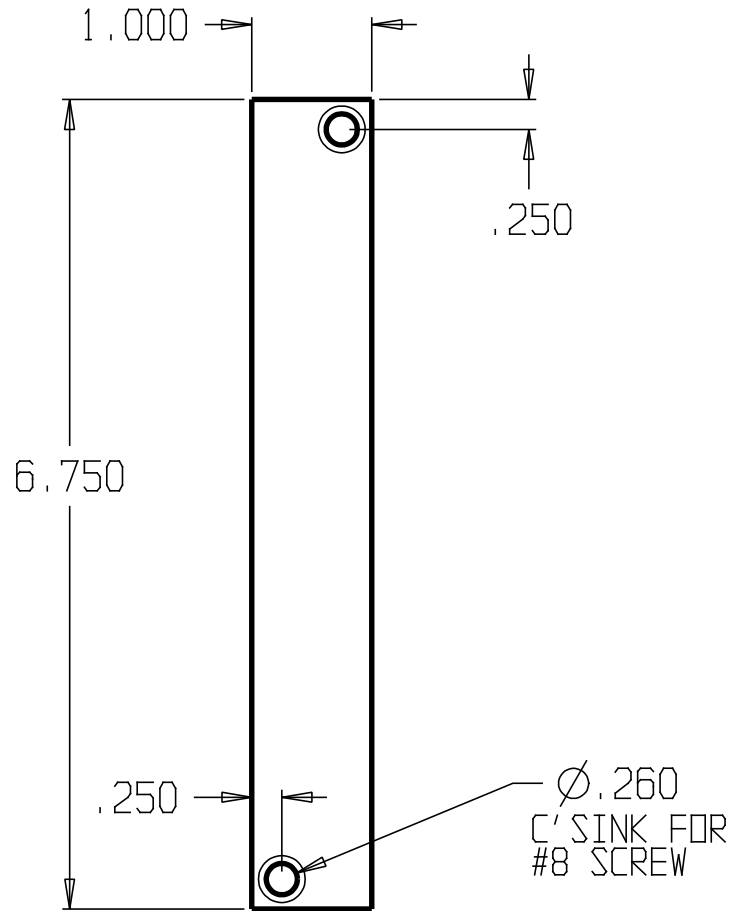

DON-JO MFG. INC.

| | | | | |
|----------|-------|--------------|----------|-------|
| DESIGNER | SIZE | DATE: | PART NO. | REV |
| | A | 5/13/04 | EF-634 | |
| APPROVED | SCALE | RELEASE DATE | WEIGHT | SHEET |
| | | | | |

| REVISIONS | | | |
|-----------|-----|-----------|-----------|
| ZONE | REV | FINISHES: | GAUGE: |
| | | PC | 7ga. .180 |

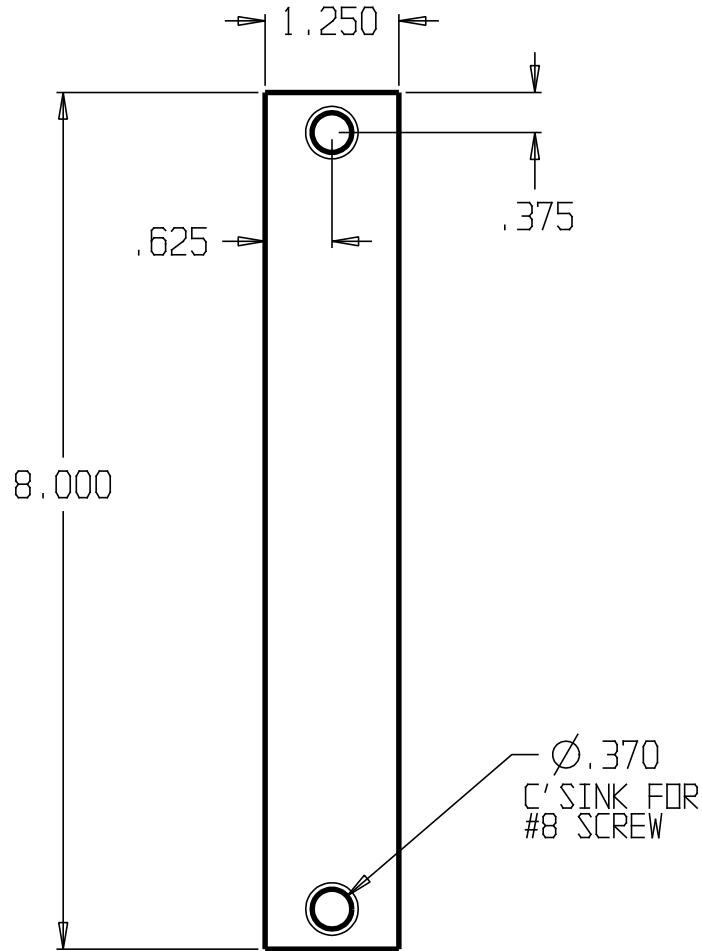

DON-JO MFG. INC.

| | | | | |
|----------|-------|--------------|----------|-------|
| DESIGNER | SIZE | DATE: | PART NO. | REV |
| | A | 5/13/04 | EF-86 | |
| APPROVED | SCALE | RELEASE DATE | WEIGHT | SHEET |
| | | | | |

| REVISIONS | | | |
|-----------|-----|-----------|--------|
| ZONE | REV | FINISHES: | GAUGE: |
| | | PC | |

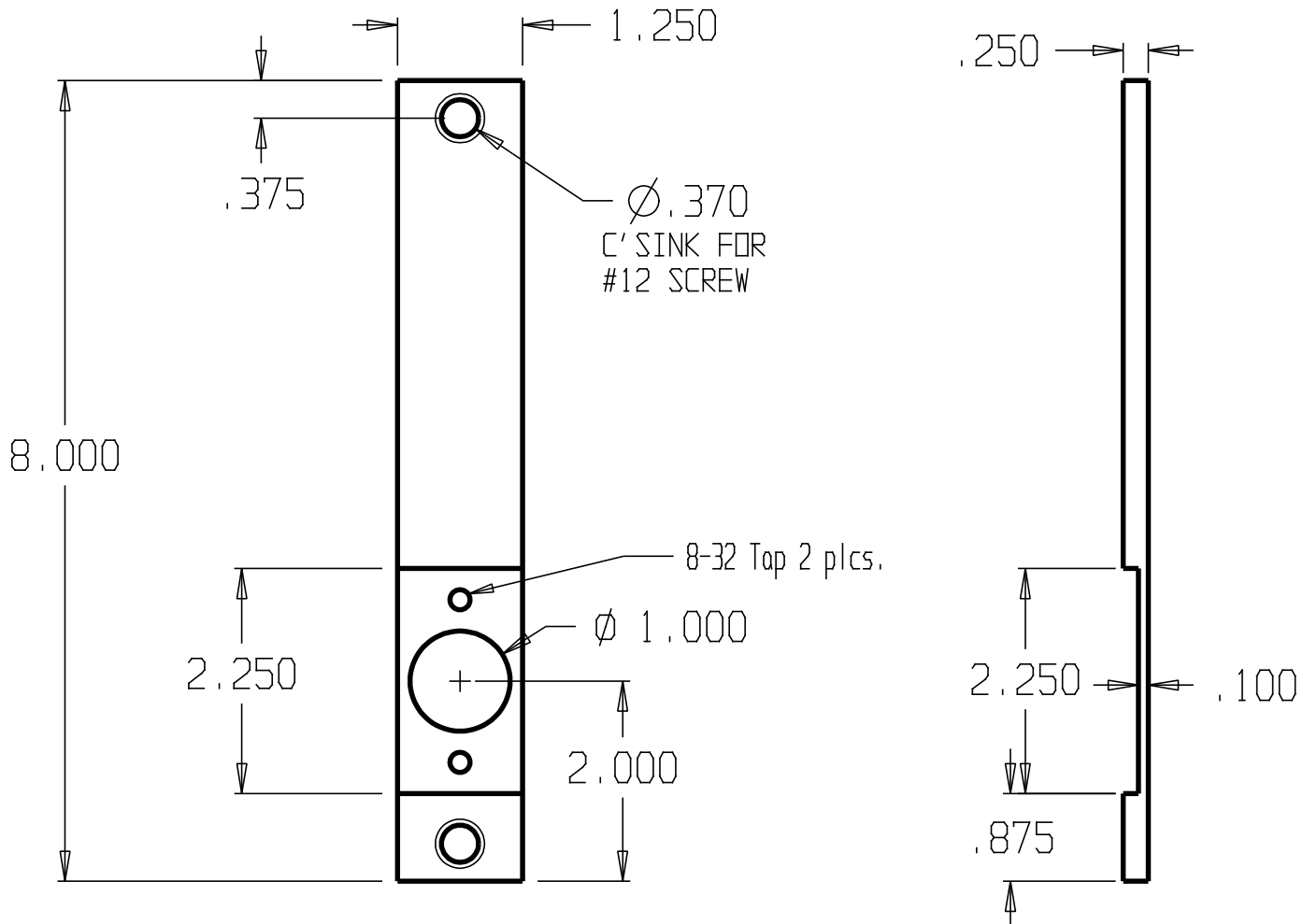

DON-JO MFG. INC.

| | | | | | |
|----------|----------|-----------|------------------|-------------------|-------|
| DESIGNER | APPROVED | SIZE A | DATE: 5/14/04 | PART NO. EL-86 | REV |
| | | SCALE | RELEASE DATE | WEIGHT | SHEET |

| REVISIONS | | | |
|-----------|-----|------------|--------|
| ZONE | REV | FINISHES: | GAUGE: |
| | | PRIME COAT | 1/4" |

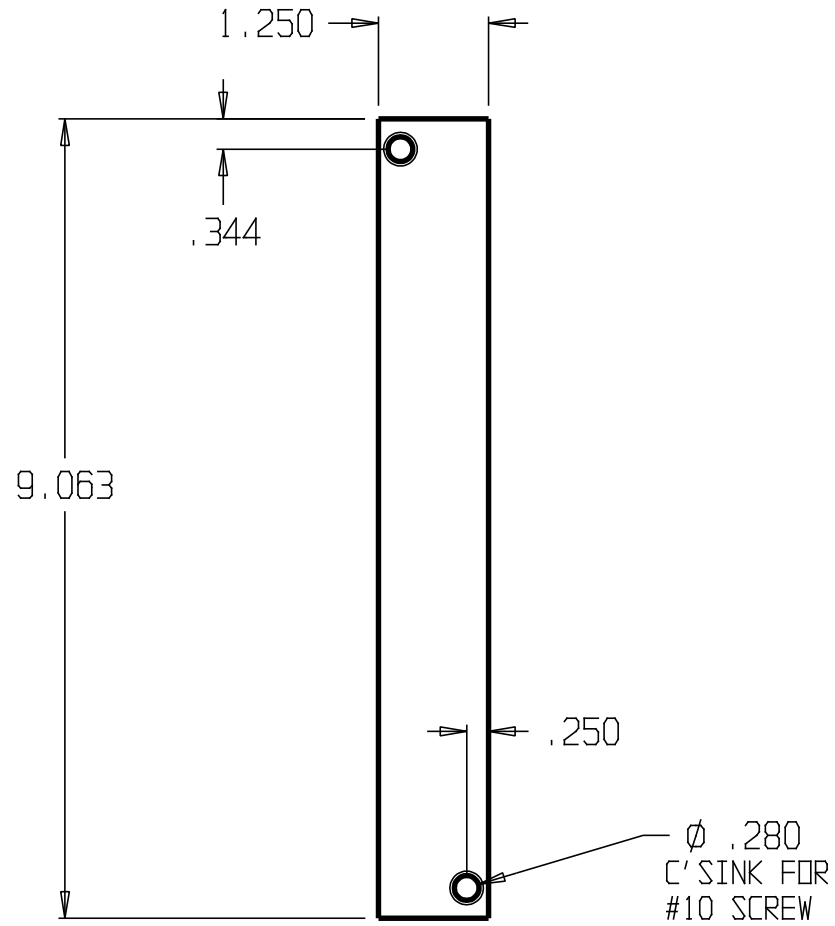

DON-JO MFG. INC.

| | | | | |
|----------|-----------|-------------------|-------------------|-------|
| DESIGNER | SIZE A | DATE: 11/15/04 | PART NO. EPT-1 | REV |
| APPROVED | SCALE | RELEASE DATE | WEIGHT | SHEET |

| REVISIONS | | | |
|-----------|-----|------------|------------|
| ZONE | REV | FINISHES : | GALUGE : |
| | | PC | 11ga. .119 |

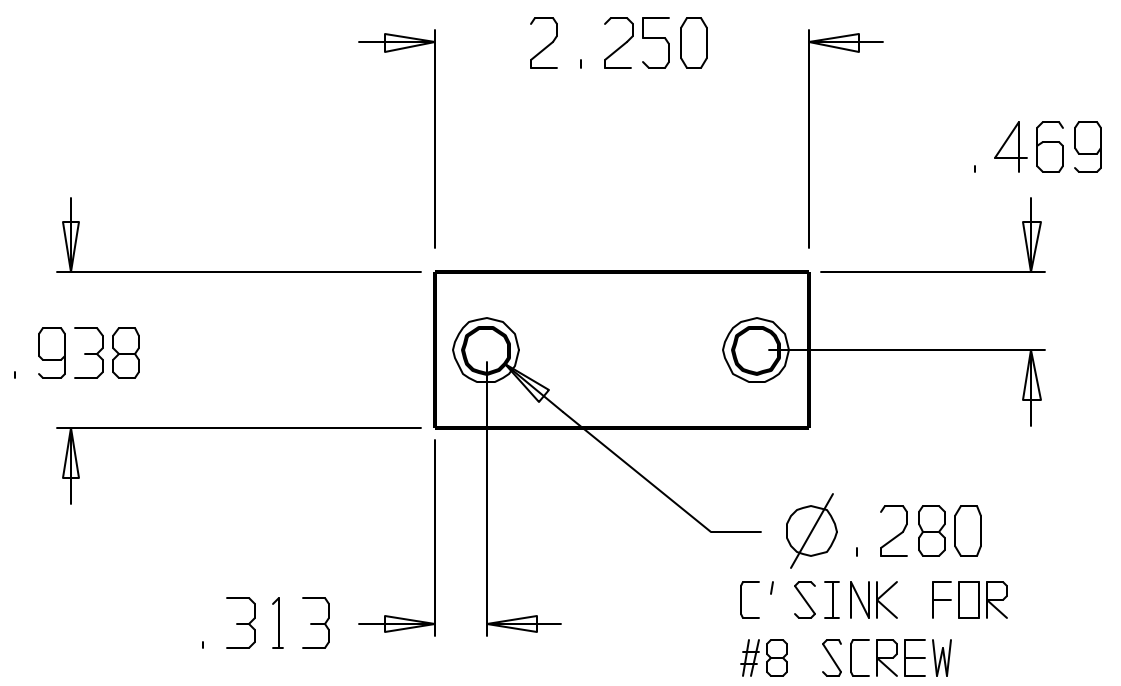

| | | | | | |
|------------------|--|-------|--------------|----------|-------|
| DON-JO MFG. INC. | | SIZE | DATE: | PART NO. | REV |
| DESIGNER | | A | 2/18/10 | FB-225 | |
| APPROVED | | SCALE | RELEASE DATE | WEIGHT | SHEET |

DWG NO

SH

REV

REVISIONS

ZONE

REV

FINISHES :

PC

GALIGE :

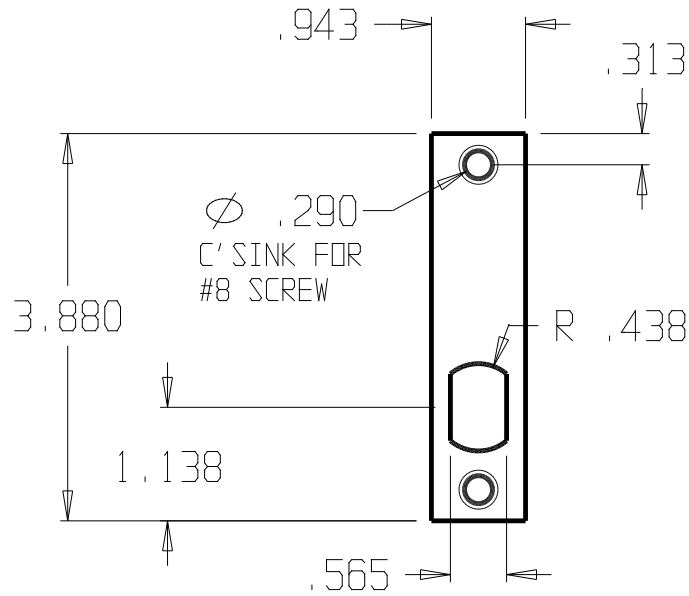

16ga. .060

DON-JO MFG. INC.

DESIGNER

SIZE

DATE:

PART NO.

REV

A

5/17/04

FBR-A

APPROVED

SCALE

RELEASE DATE

WEIGHT

SHEET

| REVISIONS | | | |
|-----------|-----|------------|----------|
| ZONE | REV | FINISHES : | GALUGE : |
| | | PC | |

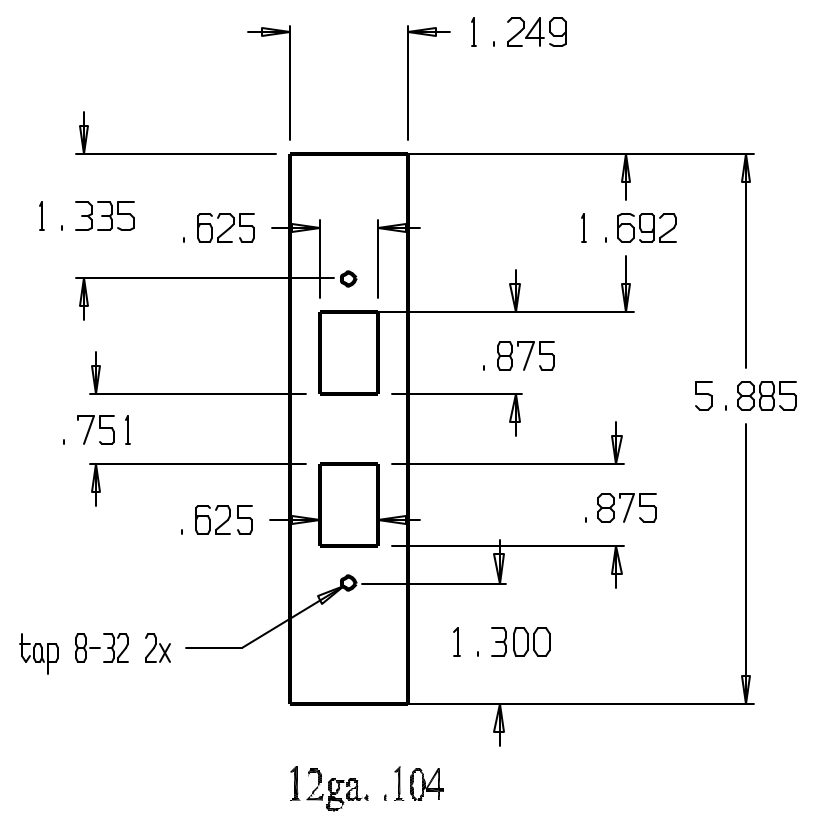
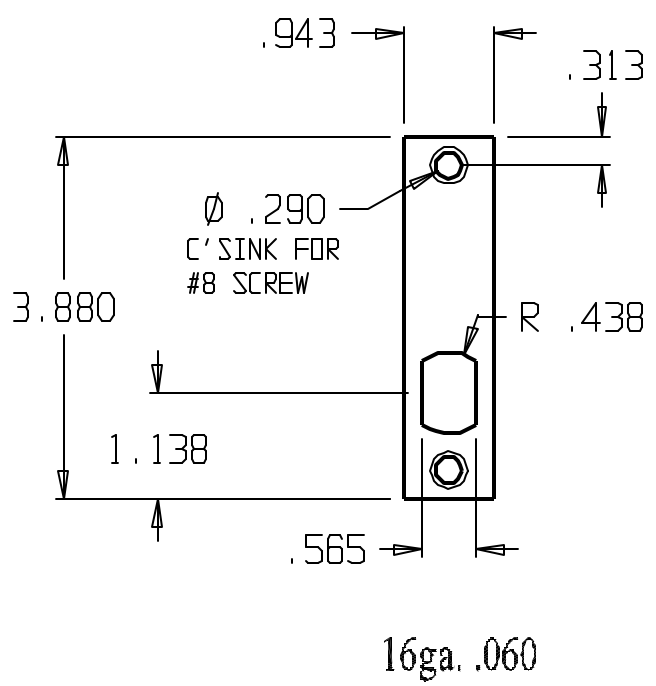

| | | | | | |
|------------------|--|-------|--------------|----------|-------|
| DON-JO MFG. INC. | | SIZE | DATE | PART NO. | REV |
| DESIGNER | | A | 5/17/04 | FBRK-2 | |
| APPROVED | | SCALE | RELEASE DATE | WEIGHT | SHEET |

| REVISIONS | | | |
|-----------|-----|------------|------------|
| ZONE | REV | FINISHES : | GALUGE : |
| | | | 11ga. .120 |

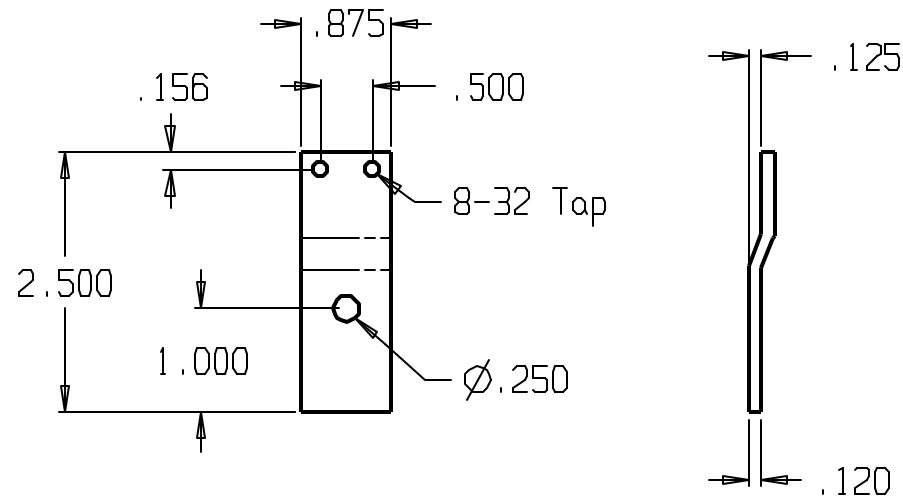

DON-JO MFG. INC.

DESIGNER
D.R.

| | | | |
|-----------|------------------|-------------------|-------|
| SIZE A | DATE: 7/16/10 | PART NO. FBT-1 | REV |
| SCALE | RELEASE DATE | WEIGHT | SHEET |

| REVISIONS | | | |
|-----------|-----|-----------|------------|
| ZONE | REV | FINISHES: | GAUGE: |
| | | PC | 10ga. .134 |

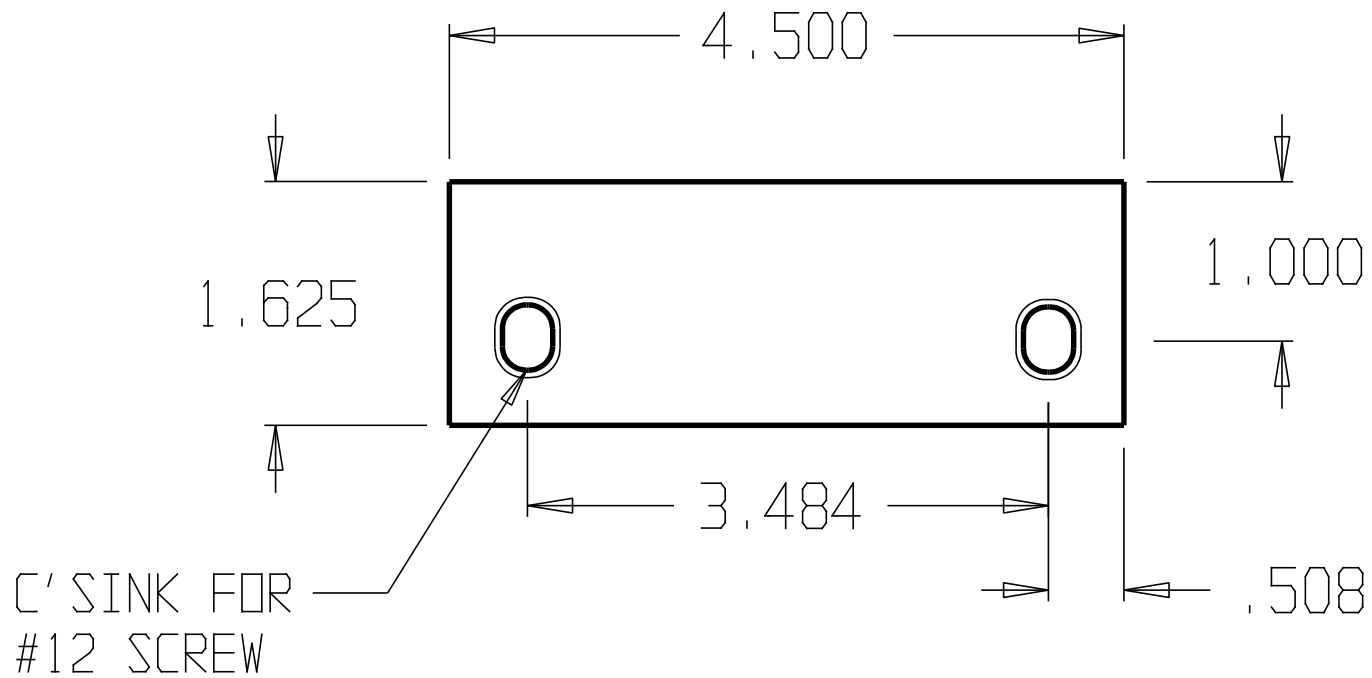

| | | | | | | | |
|------------------|--|-------|--------------|--------|-------|----------|-----|
| DON-JO MFG. INC. | | | | SIZE | DATE: | PART NO. | REV |
| DESIGNER | | A | 5/19/04 | FF-45 | | | |
| APPROVED | | SCALE | RELEASE DATE | WEIGHT | SHEET | | |

| REVISIONS | | | |
|-----------|-----|-----------|------------|
| ZONE | REV | FINISHES: | GAUGE: |
| | | PC | 10ga. .134 |

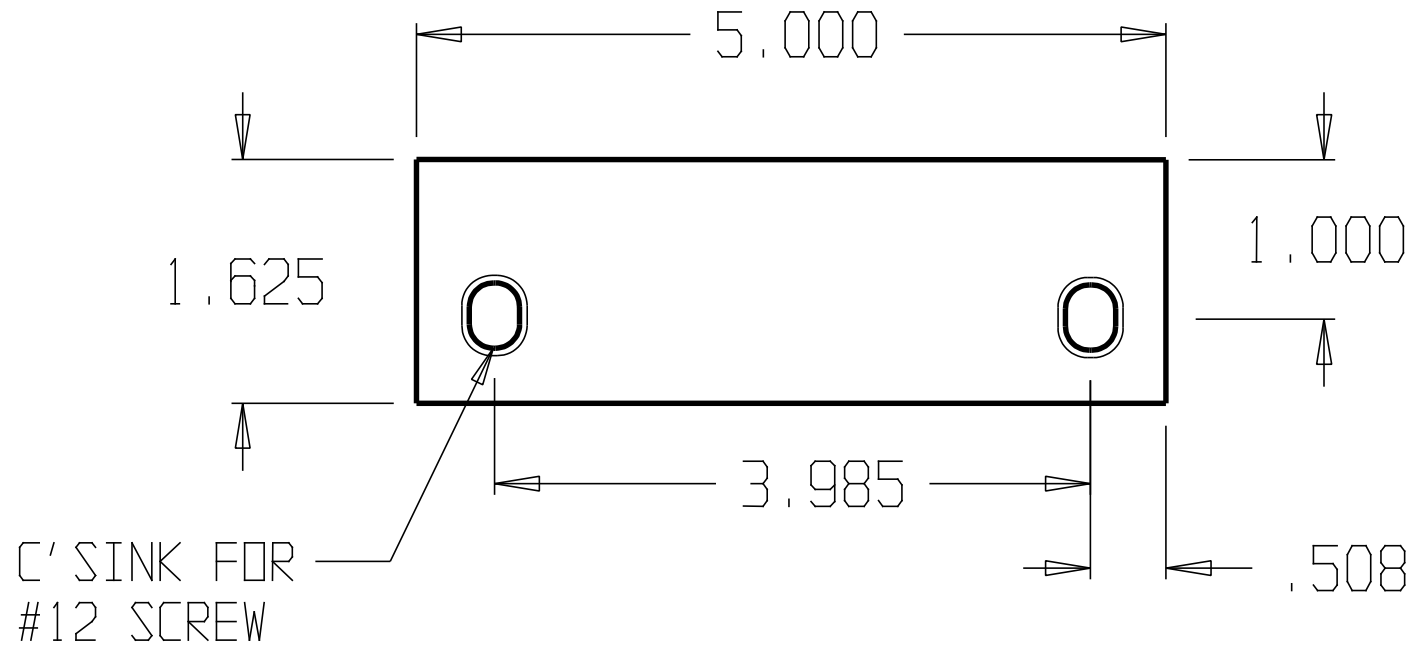

| | | | | | | | |
|------------------|--|-------|--------------|--------|-------|----------|-----|
| DON-JO MFG. INC. | | | | SIZE | DATE: | PART NO. | REV |
| DESIGNER | | A | 5/19/04 | FF-50 | | | |
| APPROVED | | SCALE | RELEASE DATE | WEIGHT | SHEET | | |

REVISIONS

| | | | |
|------|-----|-----------|------------|
| ZONE | REV | FINISHES: | GUAGE: |
| | | PC | 13ga. .090 |

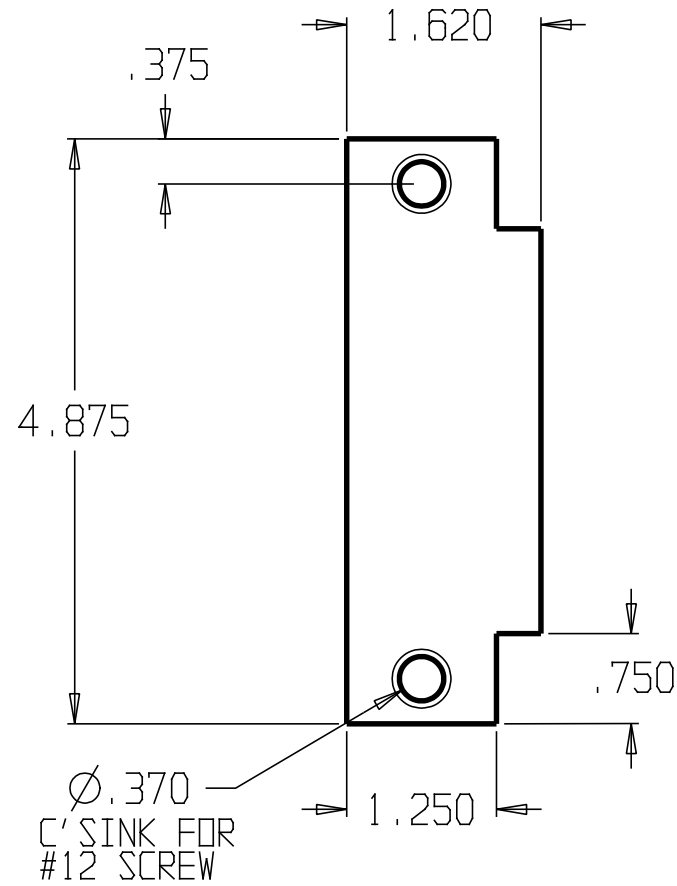

DON-JO MFG. INC.

| | | | | |
|----------|-------|--------------|----------|-------|
| DESIGNER | SIZE | DATE: | PART NO. | REV |
| | A | 5/19/04 | FS-260 | |
| APPROVED | SCALE | RELEASE DATE | WEIGHT | SHEET |
| | | | | |

| REVISIONS | | | | |
|-----------|-----|---------------|------|----------|
| ZONE | REV | FINISHES: | DATE | APPROVED |
| | | WHITE ON BLUE | | |

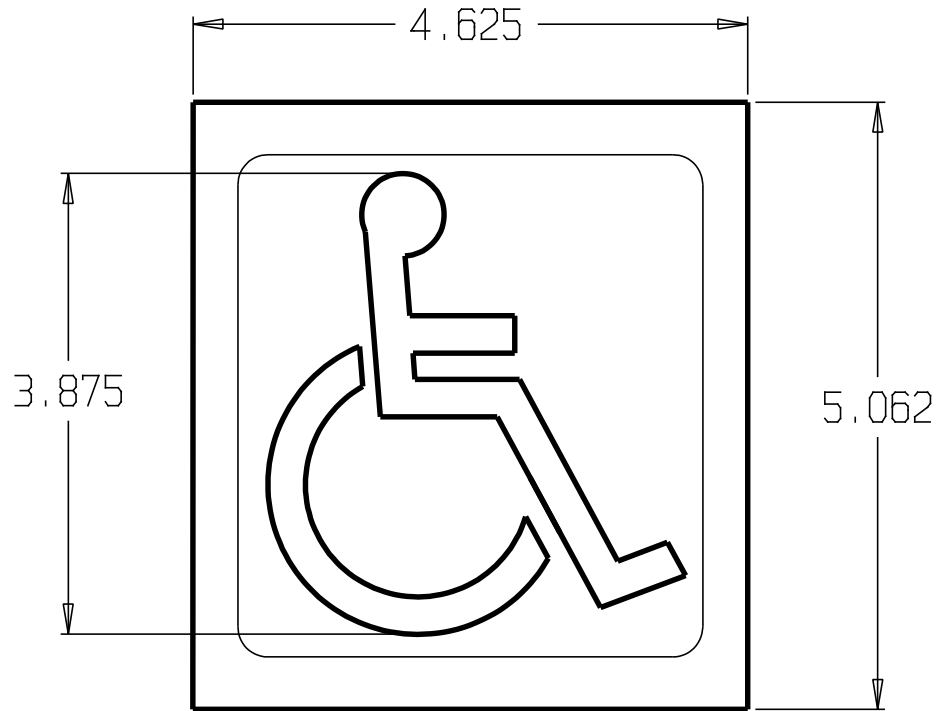

DON-JO MFG. INC.

| | | | | |
|----------|-----------|------------------|------------------|-------|
| DESIGNER | SIZE A | DATE: 5/20/04 | PART NO. HD-1 | REV |
| | SCALE | RELEASE DATE | WEIGHT | SHEET |

| REVISIONS | | | |
|-----------|-----|-----------|------------|
| ZONE | REV | FINISHES: | GAUGE: |
| | | PC | 10ga. .134 |

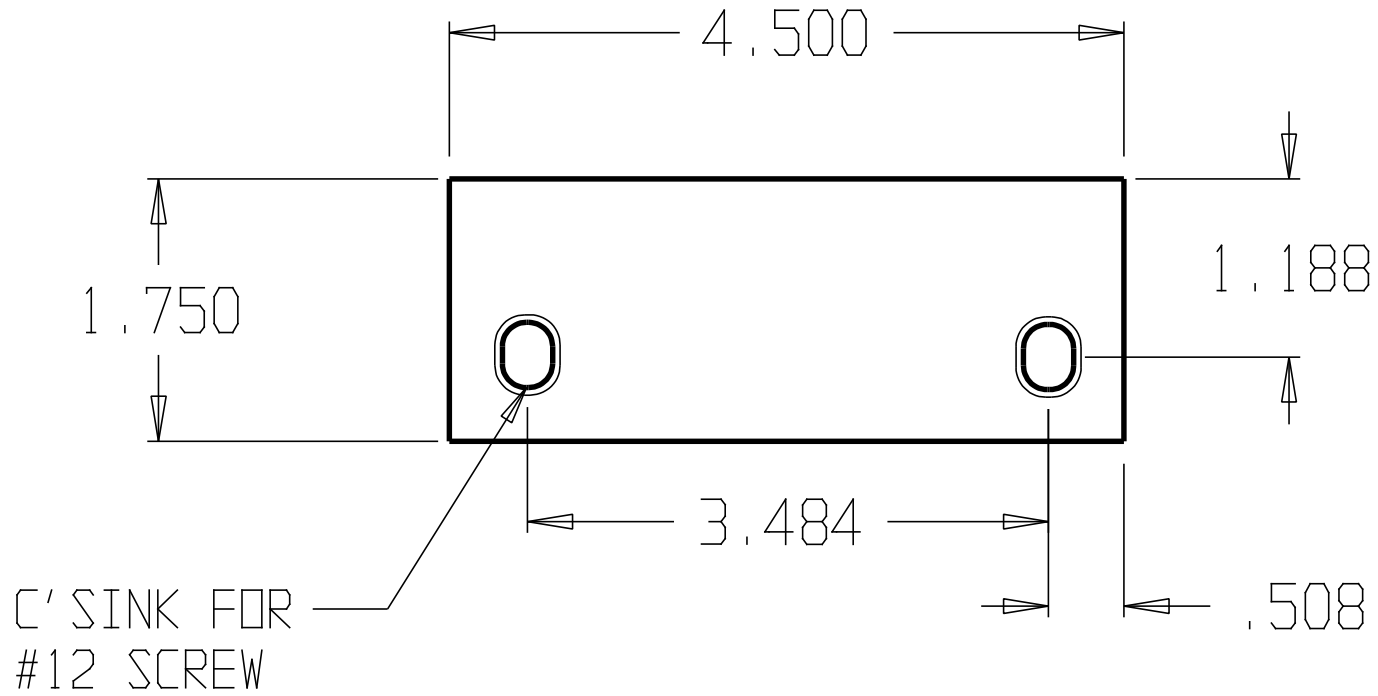

| | | | | | | | |
|------------------|--|-------|--------------|--------|-------|----------|-----|
| DON-JO MFG. INC. | | | | SIZE | DATE: | PART NO. | REV |
| DESIGNER | | A | 5/19/04 | HF-45 | | | |
| APPROVED | | SCALE | RELEASE DATE | WEIGHT | SHEET | | |

| REVISIONS | | | |
|-----------|-----|-----------|------------|
| ZONE | REV | FINISHES: | GAUGE: |
| | | RAW STEEL | 10ga. .134 |

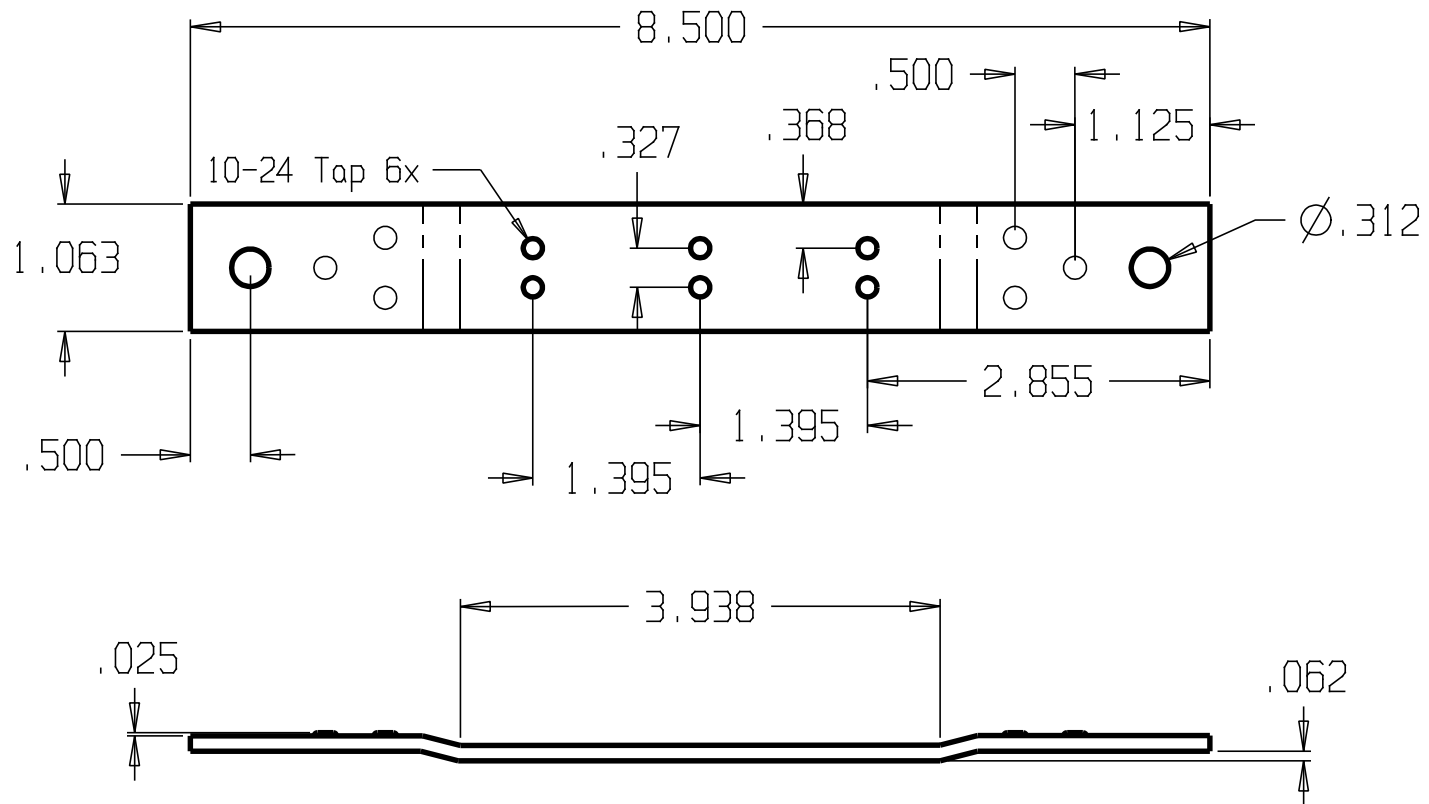

| | | | | | | | |
|-------------------------|--|-------|--------------|--------|-------|----------|-----|
| DON-JO MFG. INC. | | | | SIZE | DATE: | PART NO. | REV |
| DESIGNER | | A | 5/20/04 | HR-100 | | | |
| APPROVED | | SCALE | RELEASE DATE | WEIGHT | SHEET | | |

| REVISIONS | | | |
|-----------|-----|-----------|-----------|
| ZONE | REV | FINISHES: | GUAGE: |
| | | RAW STEEL | 7ga. .179 |

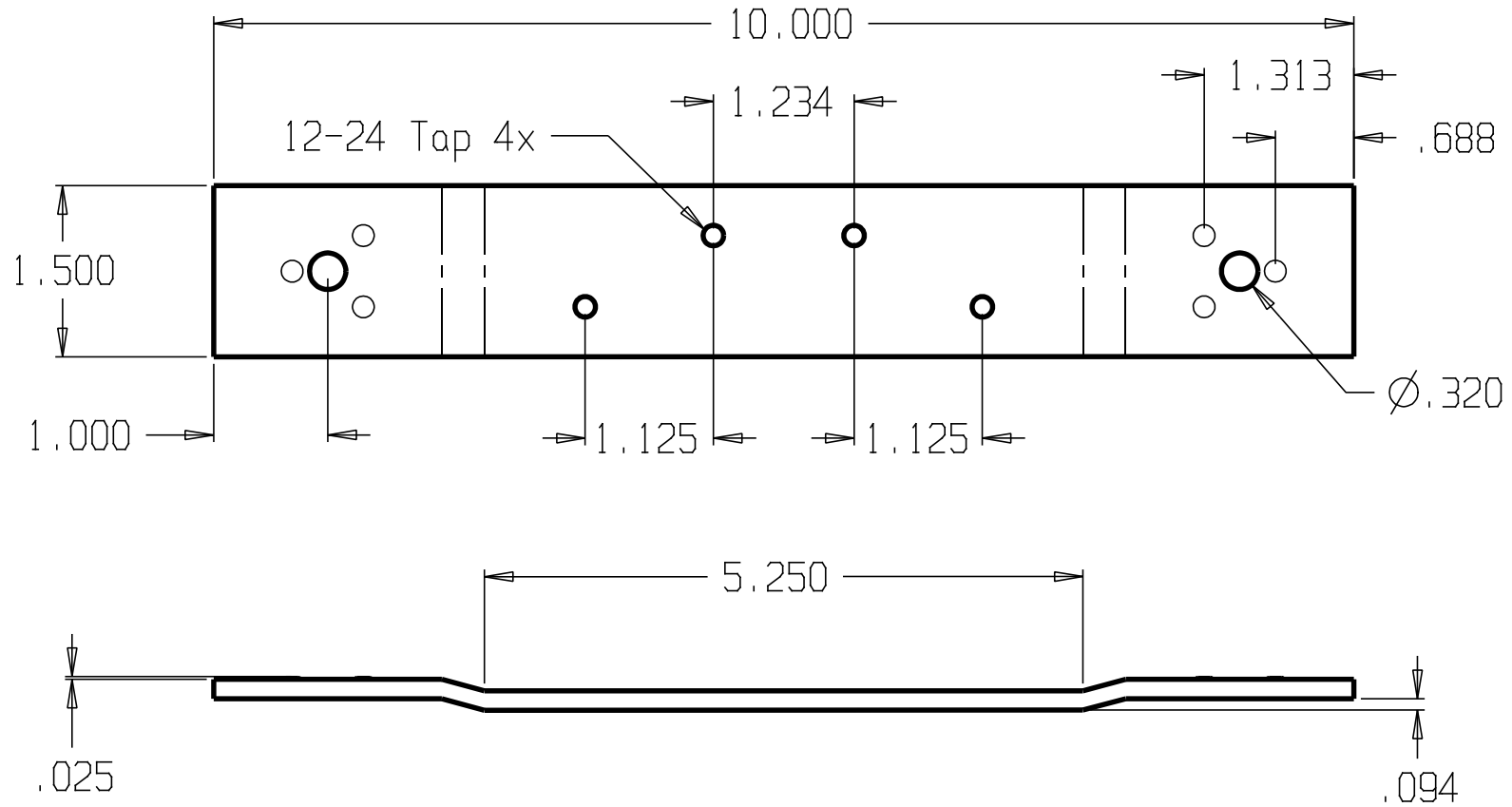

| | | | | | |
|------------------|--|-------|--------------|----------|-------|
| DON-JO MFG. INC. | | SIZE | DATE: | PART NO. | REV |
| DESIGNER | | A | 5/21/04 | HR-130 | |
| APPROVED | | SCALE | RELEASE DATE | WEIGHT | SHEET |

| REVISIONS | | |
|-----------|-----|-----------|
| ZONE | REV | FINISHES: |
| | | RAW STEEL |
| | | GAUGE: |
| | | 7ga. .179 |

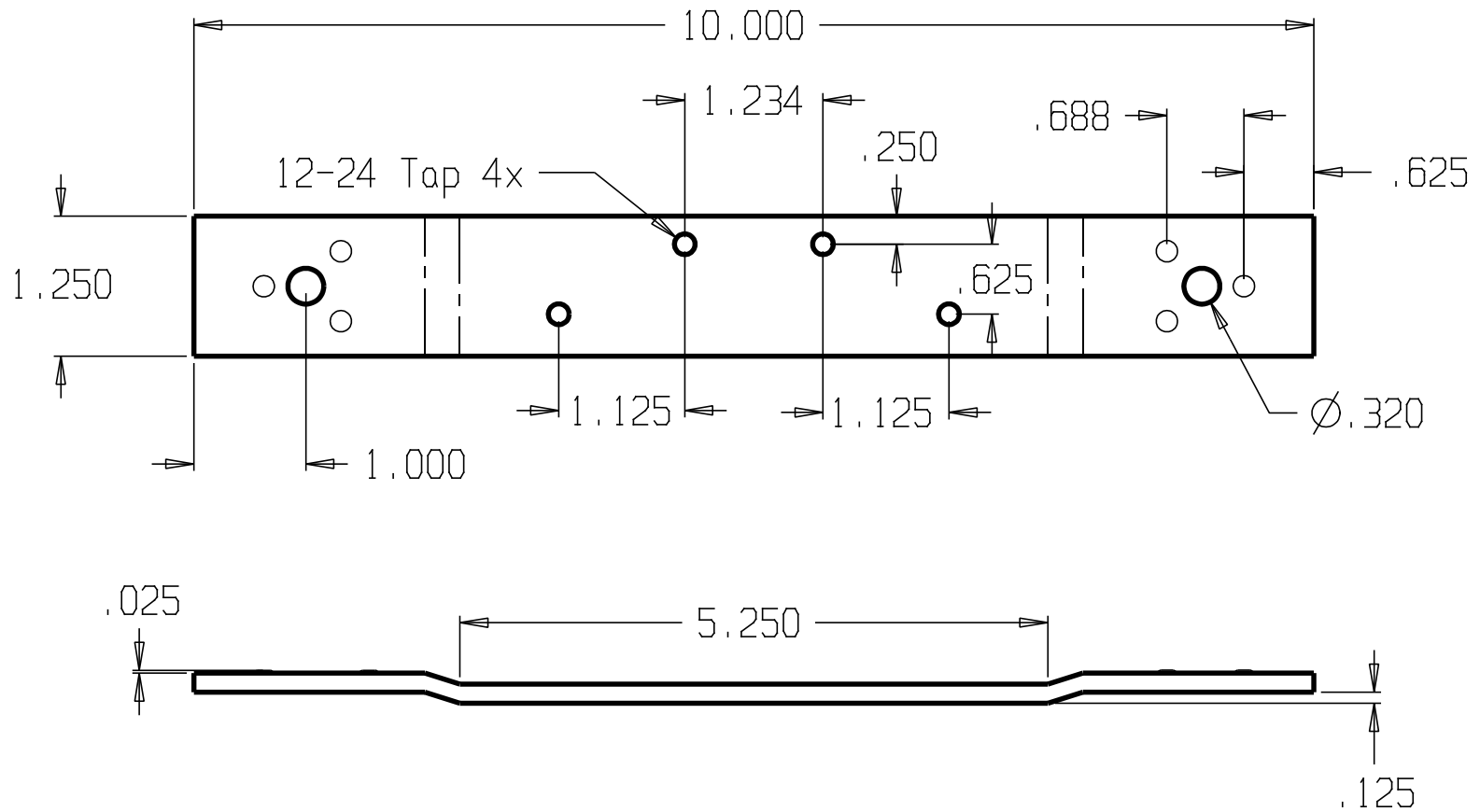

| | | | | | |
|------------------|--|-------|--------------|----------|-------|
| DON-JO MFG. INC. | | SIZE | DATE: | PART NO. | REV |
| | | A | 5/21/04 | HR-140 | |
| DESIGNER | | SCALE | RELEASE DATE | WEIGHT | SHEET |
| APPROVED | | | | | |

| REVISIONS | | FINISHES: | GUAGE: |
|-----------|-----|-----------|-----------|
| ZONE | REV | RAW STEEL | 7ga. .179 |

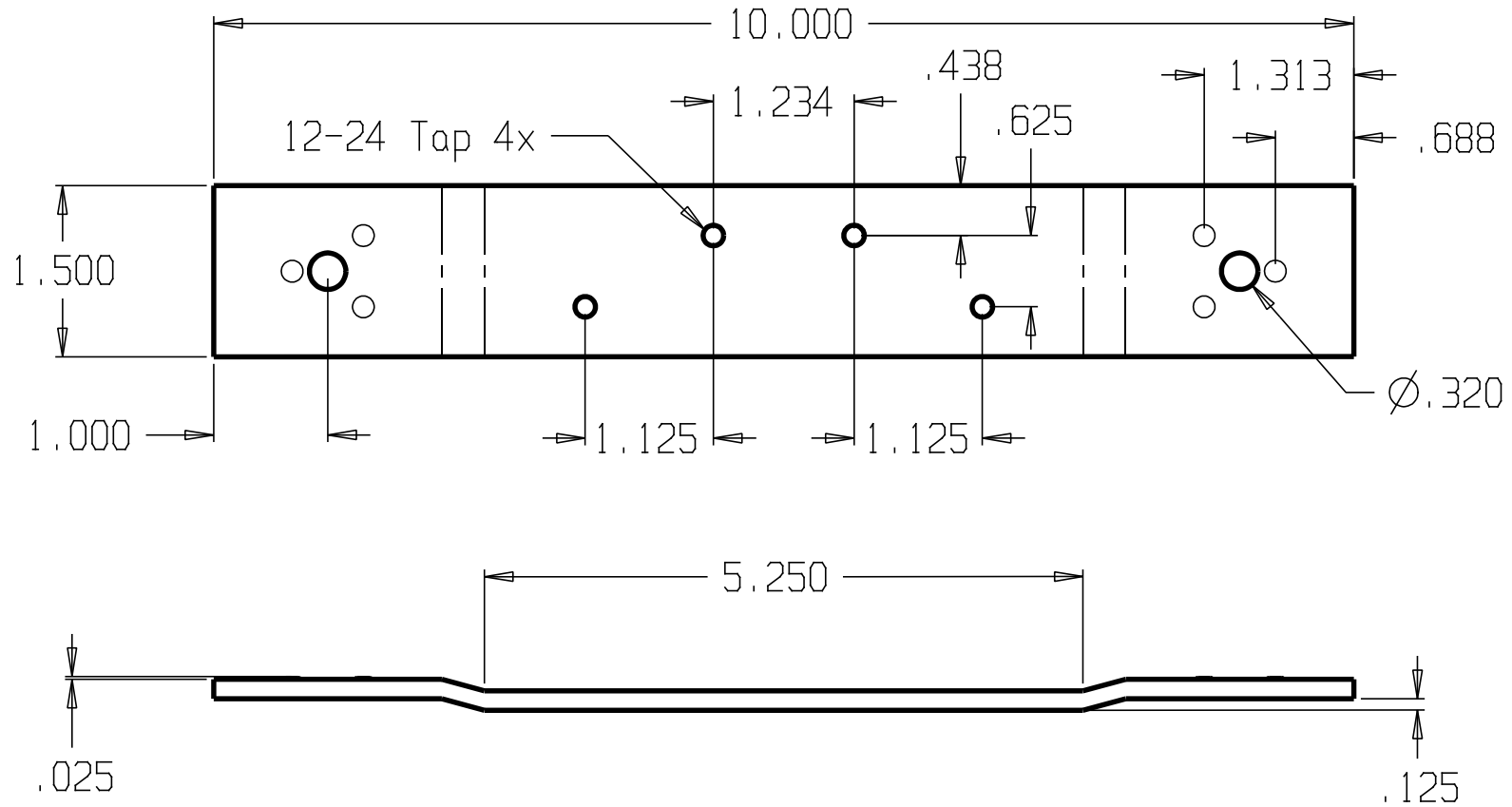

DON-JO MFG. INC.

| | | | | |
|----------|-------|--------------|----------|-------|
| DESIGNER | SIZE | DATE: | PART NO. | REV |
| | A | 5/21/04 | HR-150 | |
| APPROVED | SCALE | RELEASE DATE | WEIGHT | SHEET |

| REVISIONS | | |
|-----------|-----|-----------|
| ZONE | REV | FINISHES: |
| | | RAW STEEL |
| | | GAUGE: |
| | | 7ga. .179 |

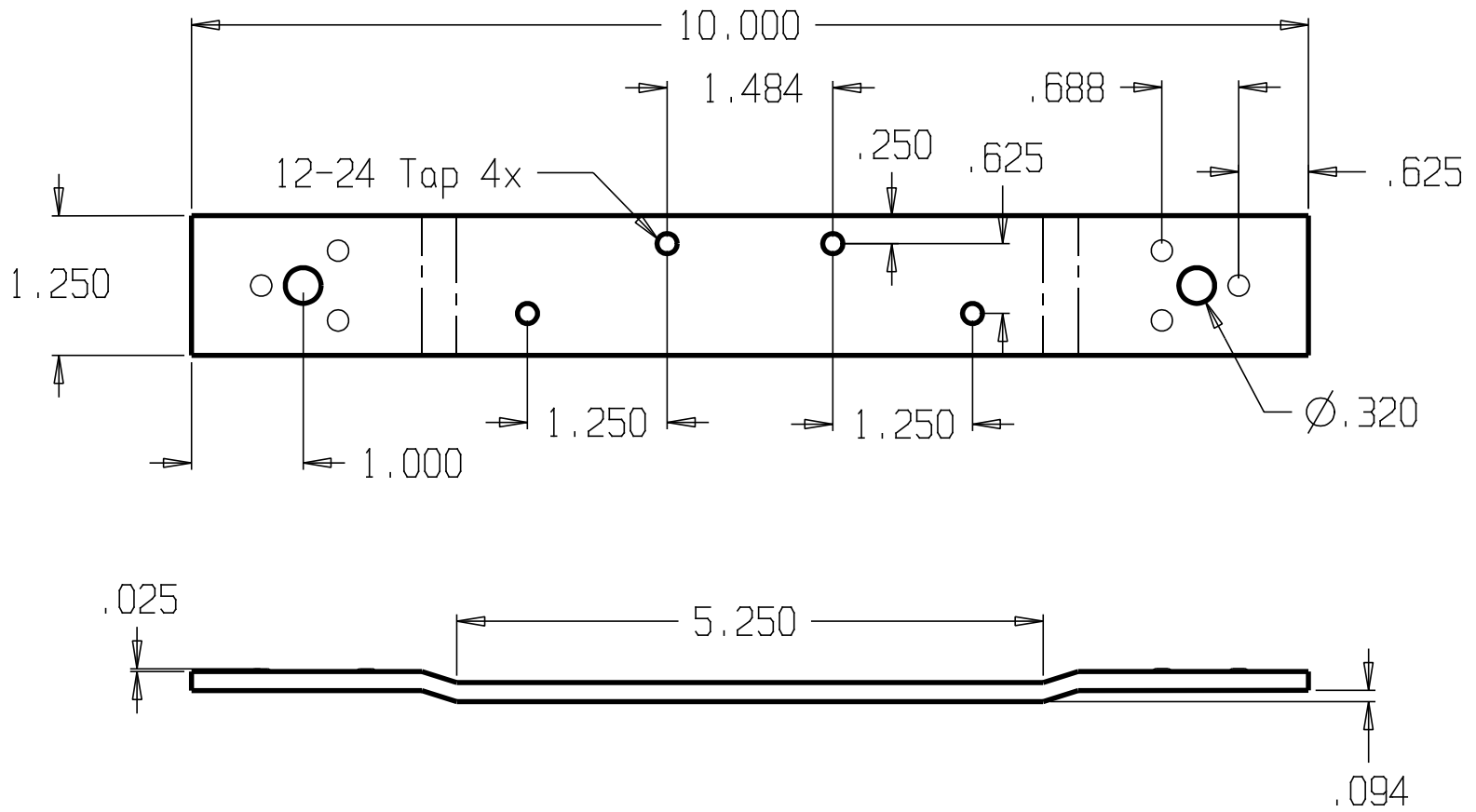

DON-JO MFG. INC.

| | |
|----------|--|
| DESIGNER | |
| APPROVED | |

| | | | |
|-------|--------------|----------|-------|
| SIZE | DATE: | PART NO. | REV |
| A | 5/21/04 | HR-160 | |
| SCALE | RELEASE DATE | WEIGHT | SHEET |

| REVISIONS | | FINISHES: | GUAGE: |
|-----------|-----|-----------|-----------|
| ZONE | REV | RAW STEEL | 7ga. .179 |

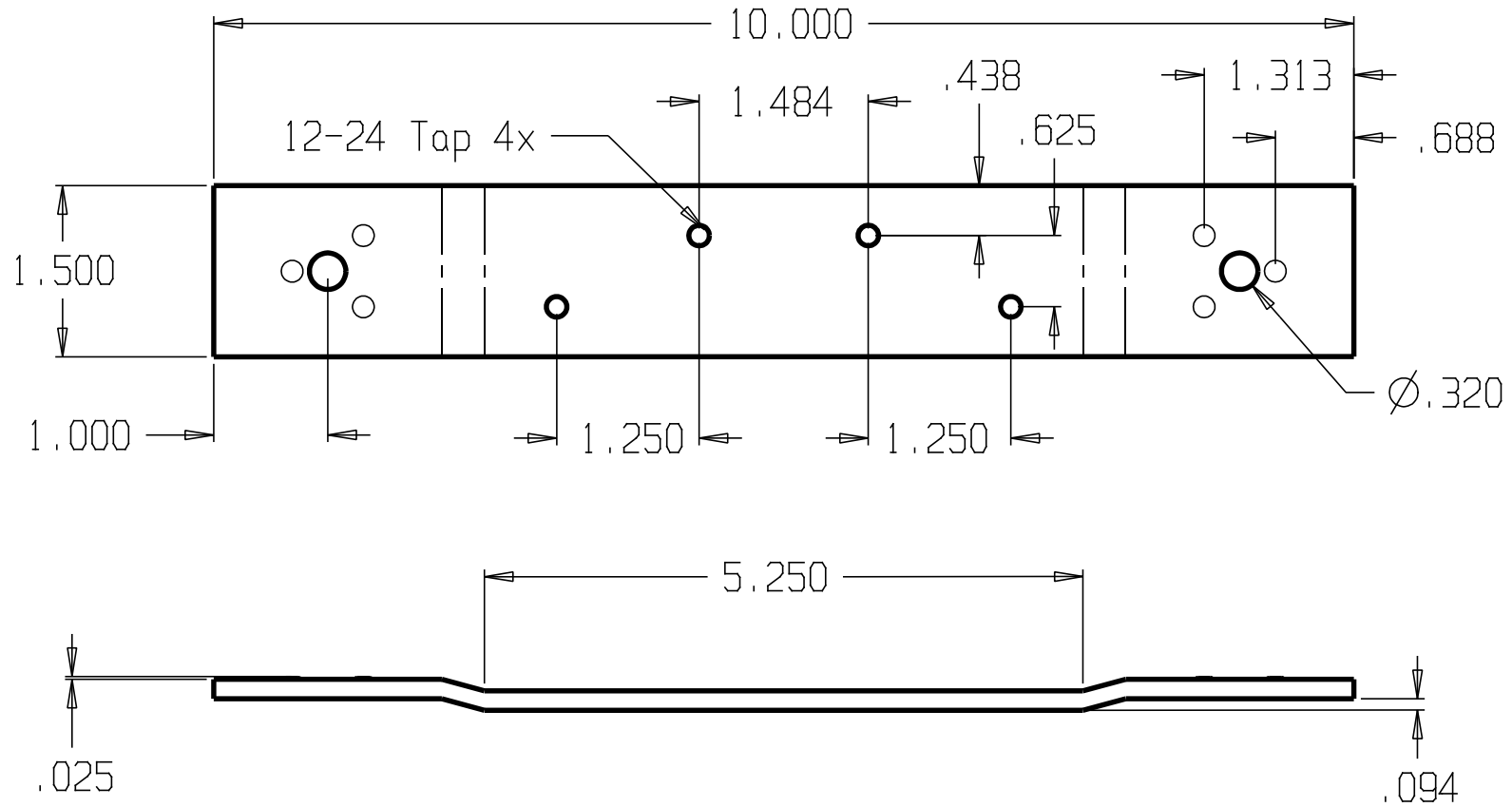

DON-JO MFG. INC.

| | | | | |
|----------|-------|--------------|----------|-------|
| DESIGNER | SIZE | DATE: | PART NO. | REV |
| | A | 5/21/04 | HR-170 | |
| APPROVED | SCALE | RELEASE DATE | WEIGHT | SHEET |

| REVISIONS | | |
|-----------|-----|-----------|
| ZONE | REV | FINISHES: |
| | | RAW STEEL |
| | | GAUGE: |
| | | 7ga. .179 |

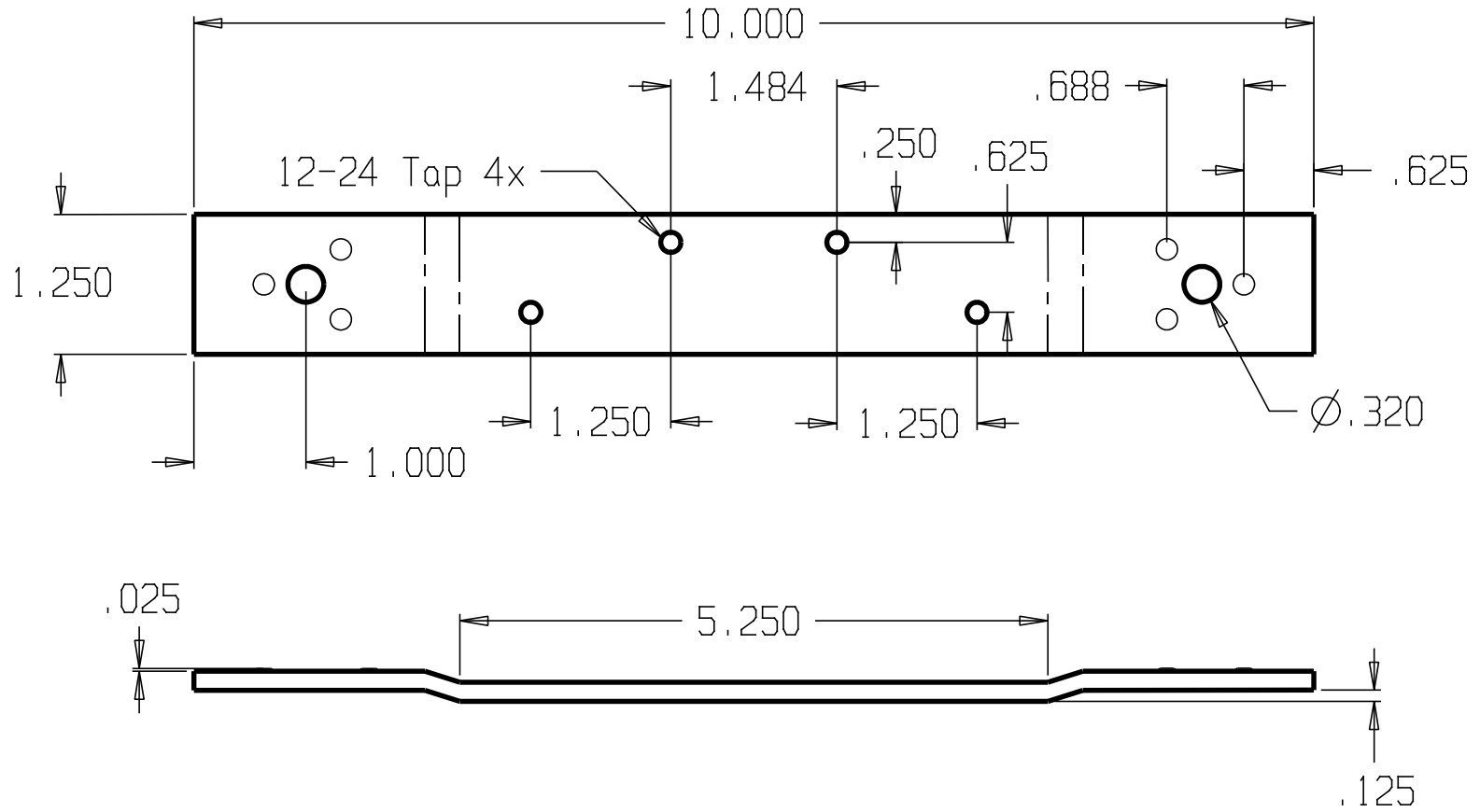

DON-JO MFG. INC.

| | | | | |
|----------|-------|--------------|----------|-------|
| DESIGNER | SIZE | DATE: | PART NO. | REV |
| | A | 5/21/04 | HR-180 | |
| APPROVED | SCALE | RELEASE DATE | WEIGHT | SHEET |

| REVISIONS | | | |
|-----------|-----|-----------|-----------|
| ZONE | REV | FINISHES: | GUAGE: |
| | | RAW STEEL | 7ga. .179 |

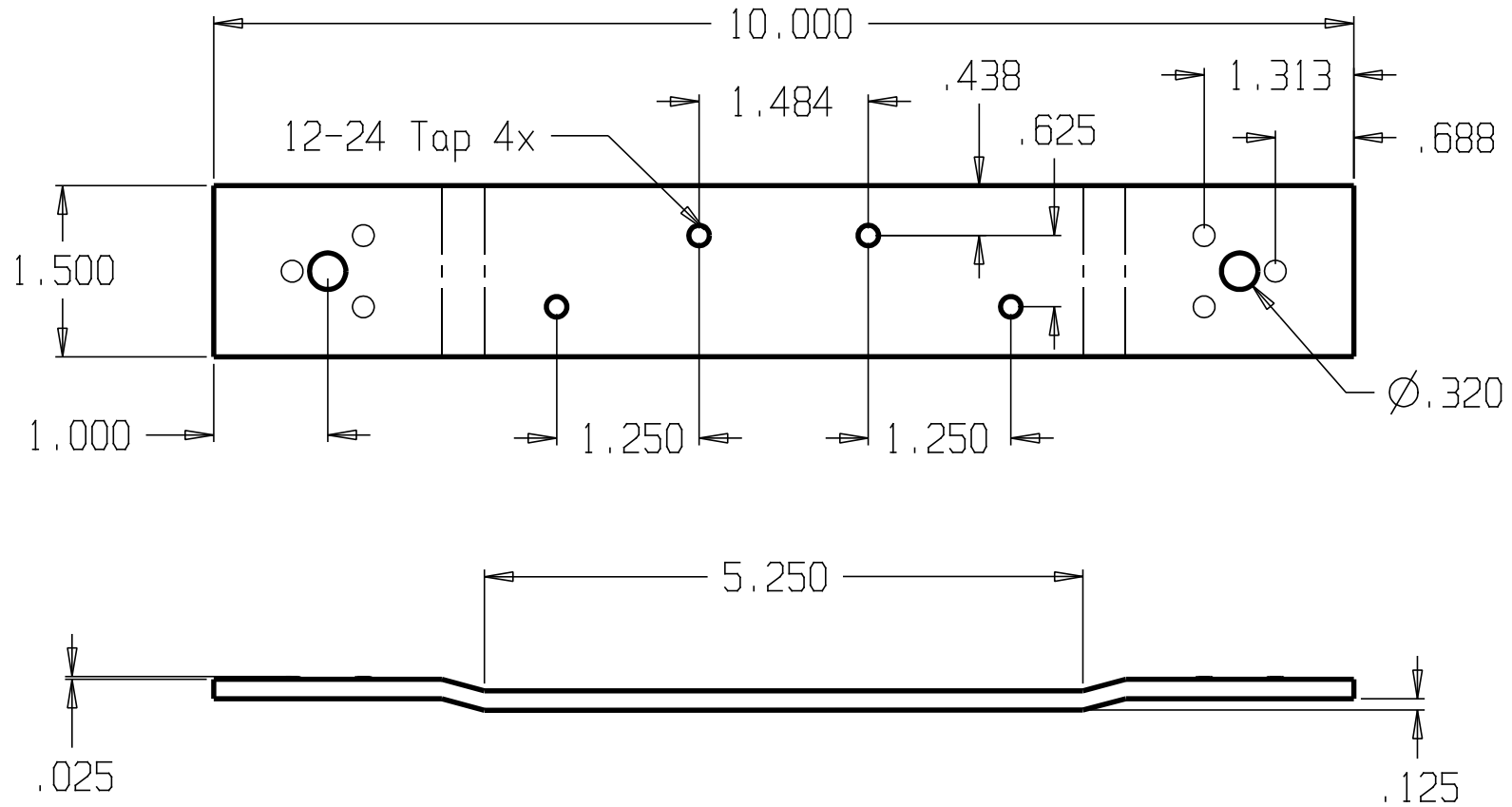

DON-JO MFG. INC.

DESIGNER
APPROVED

SIZE: A
DATE: 5/21/04
SCALE

PART NO. HR-190
REV
RELEASE DATE
WEIGHT
SHEET

| REVISIONS | | | |
|-----------|-----|-----------|-----------|
| ZONE | REV | FINISHES: | GAUGE: |
| | | RAW STEEL | 7ga. .179 |

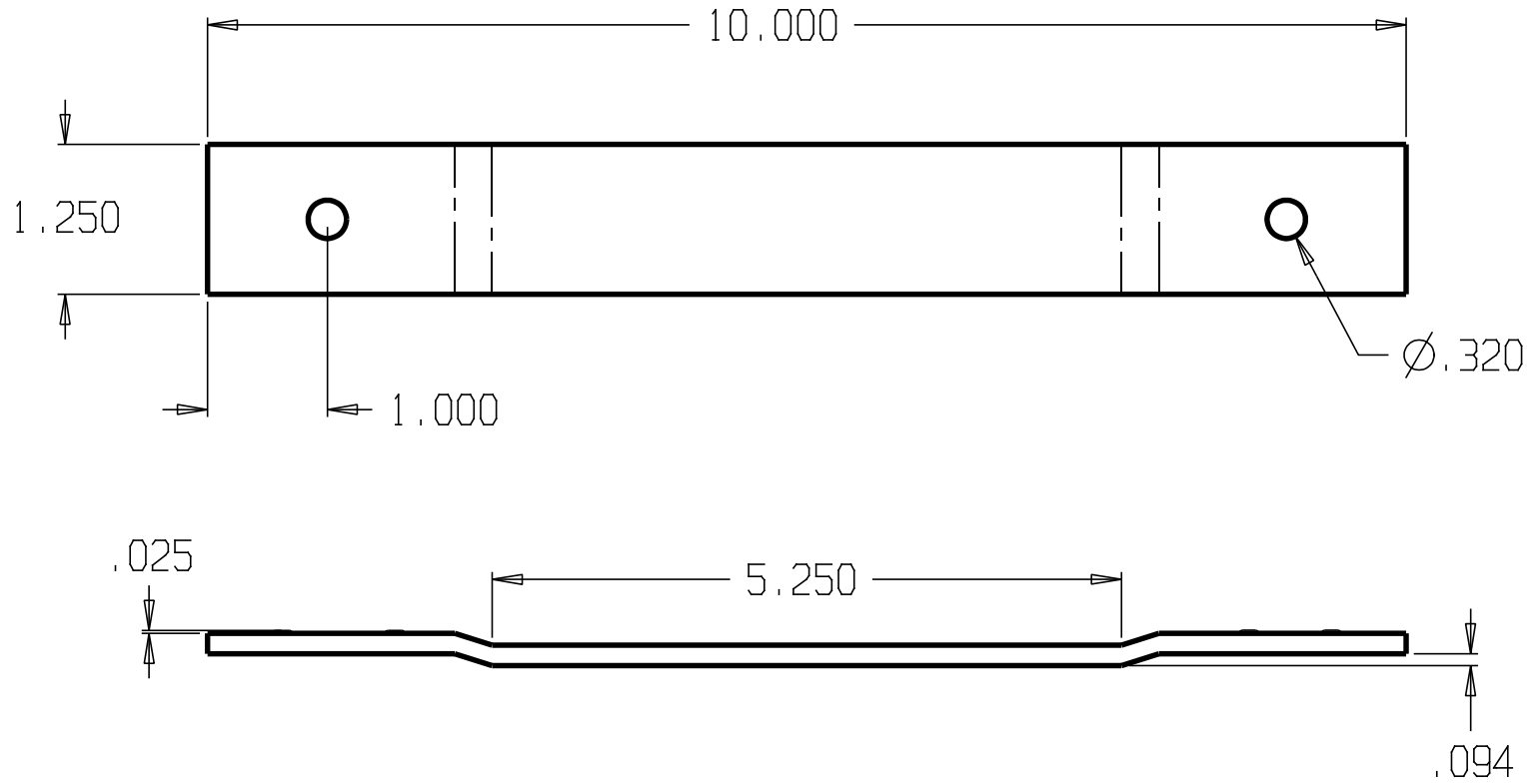

DON-JO MFG. INC.

| | |
|----------|--|
| DESIGNER | |
| APPROVED | |

| | | | |
|-------|--------------|---------------|-------|
| SIZE | DATE: | PART NO. | REV |
| A | 5/21/04 | HR-200-4 1/2" | |
| SCALE | RELEASE DATE | WEIGHT | SHEET |

| REVISIONS | | |
|-----------|-----|-----------|
| ZONE | REV | FINISHES: |
| | | RAW STEEL |
| | | GAUGE: |
| | | 7ga. .179 |

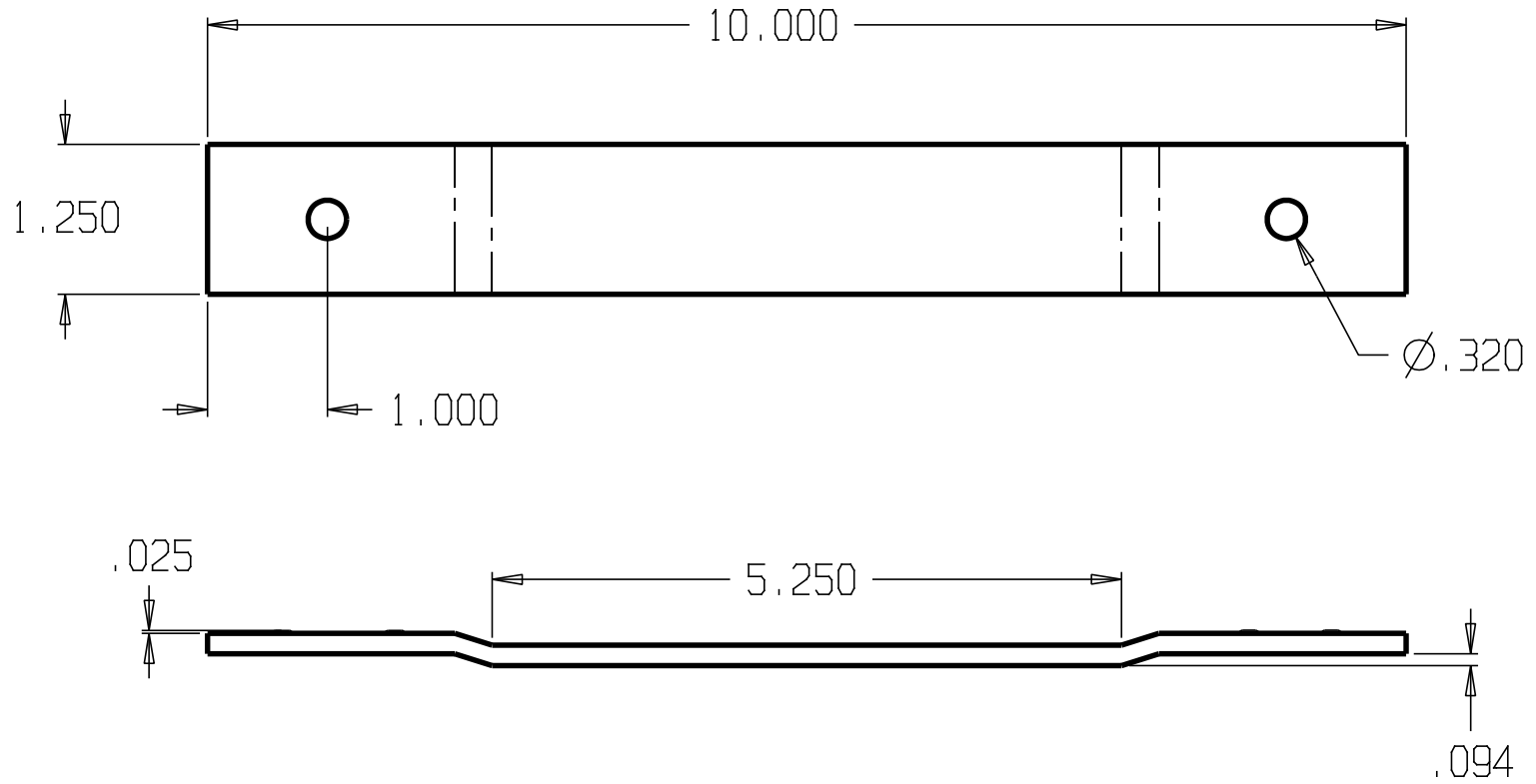

DON-JO MFG. INC.

| | |
|----------|--|
| DESIGNER | |
| APPROVED | |

| | | | |
|-------|--------------|----------|-------|
| SIZE | DATE: | PART NO. | REV |
| A | 5/21/04 | HR-210-5 | |
| SCALE | RELEASE DATE | WEIGHT | SHEET |

| REVISIONS | | |
|-----------|-----|-----------|
| ZONE | REV | FINISHES: |
| | | RAW STEEL |
| | | GUAGE: |
| | | 7ga. .179 |

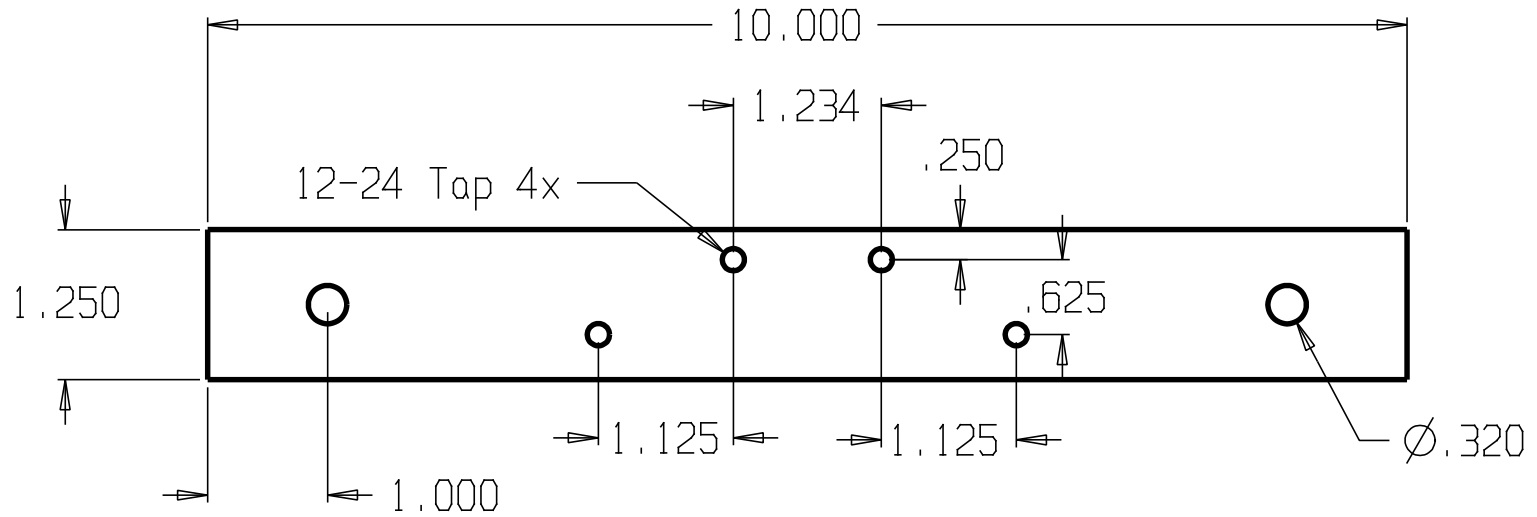

| | | | | | | | |
|------------------|--|-------|--------------|----------------|-------|----------|-----|
| DON-JO MFG. INC. | | | | SIZE | DATE: | PART NO. | REV |
| DESIGNER | | A | 5/21/04 | HR-215- 4 1/2" | | | |
| APPROVED | | SCALE | RELEASE DATE | WEIGHT | SHEET | | |

| REVISIONS | | | |
|-----------|-----|-----------|-----------|
| ZONE | REV | FINISHES: | GAUGE: |
| | | RAW STEEL | 7ga. .179 |

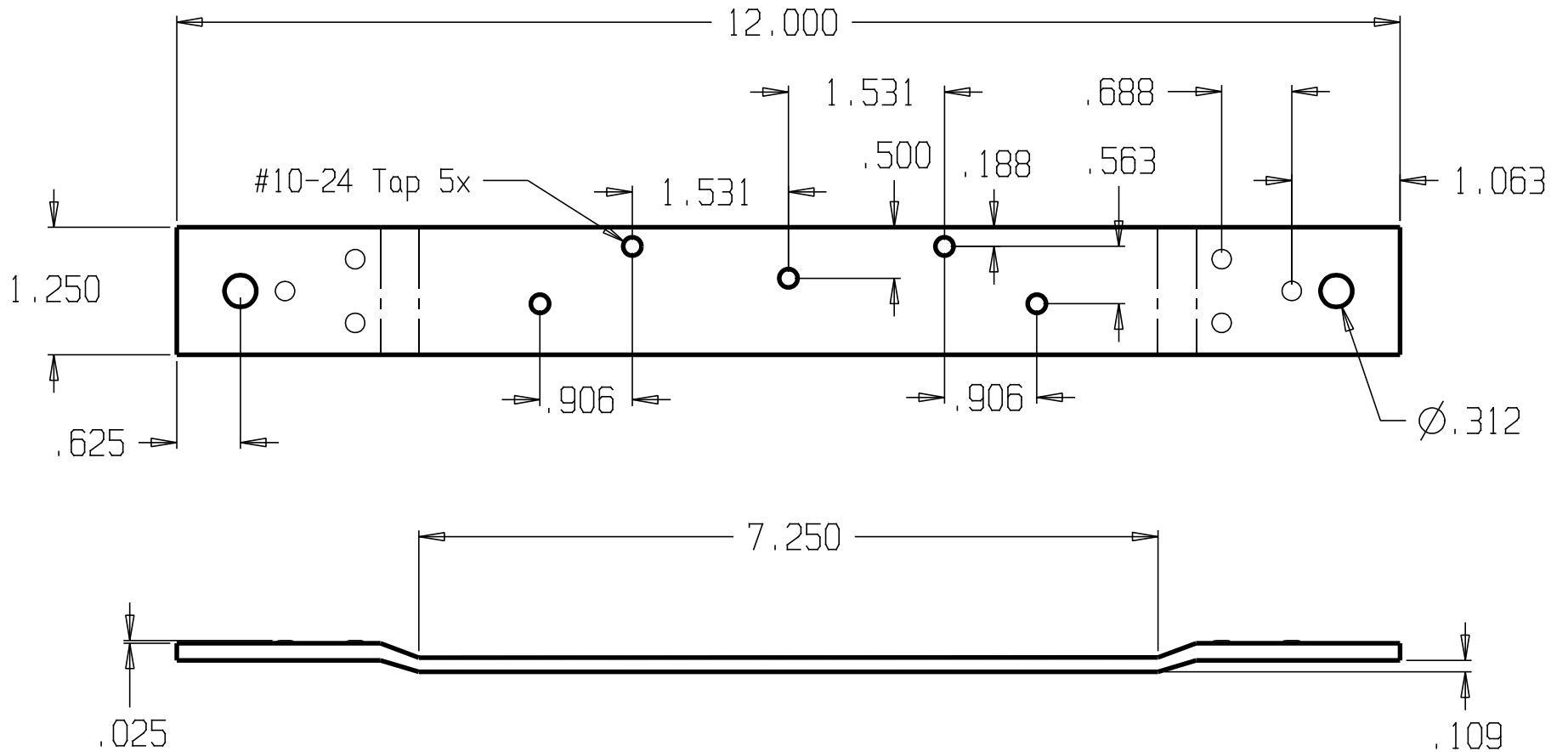

DON-JO MFG. INC.

| | | | | |
|----------|-----------|-----------------|--------------------|-------|
| DESIGNER | SIZE A | DATE 5/21/04 | PART NO. HR-217 | REV |
| APPROVED | SCALE | RELEASE DATE | WEIGHT | SHEET |

| REVISIONS | | | |
|-----------|-----|-----------|-----------|
| ZONE | REV | FINISHES: | GAUGE: |
| | | RAW STEEL | 7ga. .179 |

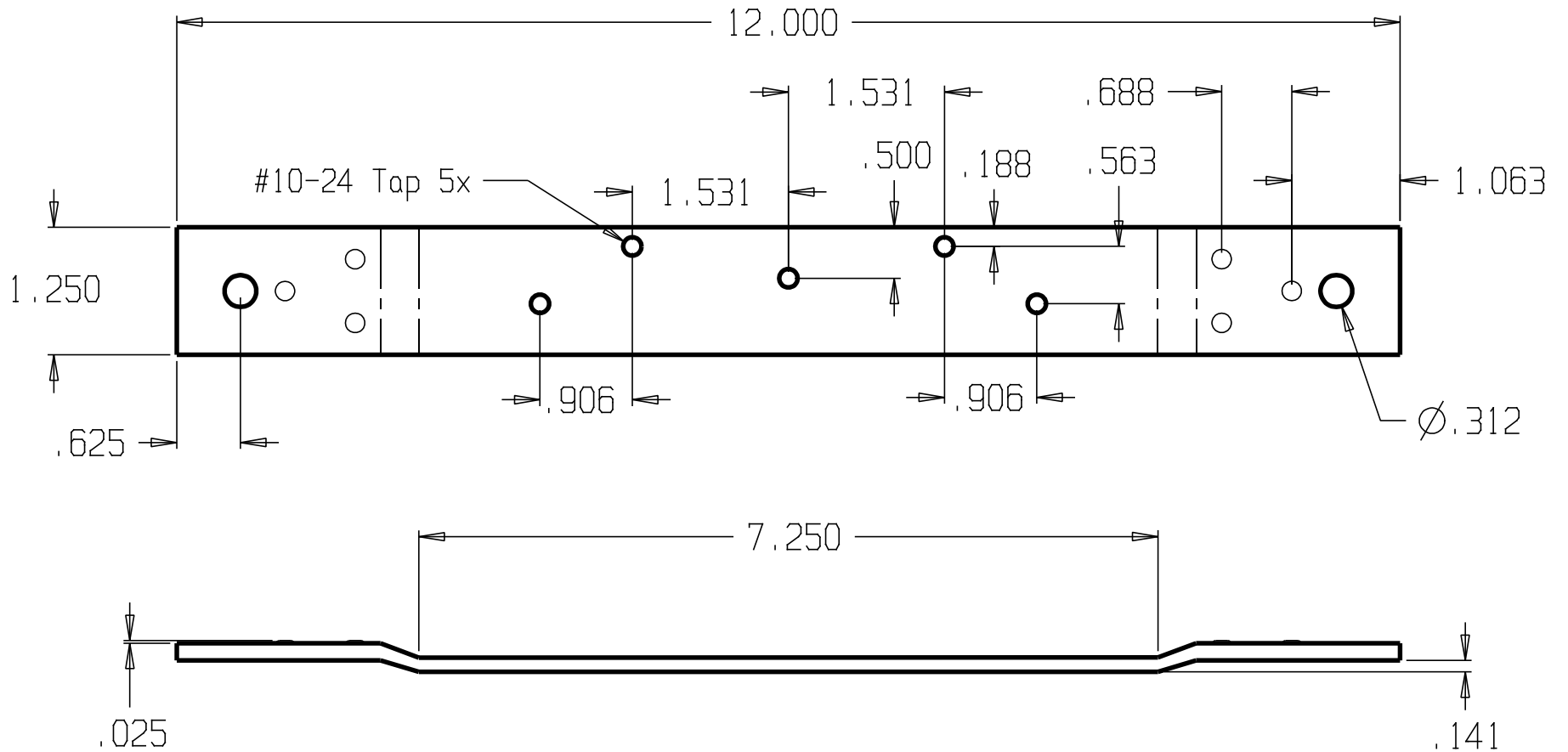

DON-JO MFG. INC.

| | | | | |
|----------|--------------|---------------|-----------------|-----|
| DESIGNER | SCALE | DATE: 5/21/04 | PART NO. HR-218 | REV |
| APPROVED | RELEASE DATE | WEIGHT | SHEET | |

DWG NO

SH

REV

REVISIONS

ZONE

REV

FINISHES :

PRIME COAT

GALIGE :

16ga. .060 C.R.S

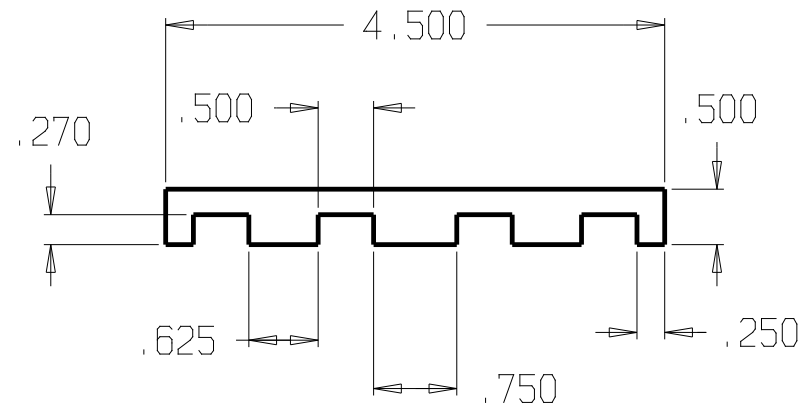

DON-JO MFG. INC.

DESIGNER

D.R.

SIZE

A

DATE:

8/18/15

PART NO.

HS-050

REV

SCALE

RELEASE DATE

WEIGHT

SHEET

DWG NO

SH

REV

REVISIONS

ZONE

REV

FINISHES :

PRIME COAT

GALIGE :

13ga. .090 C.R.S

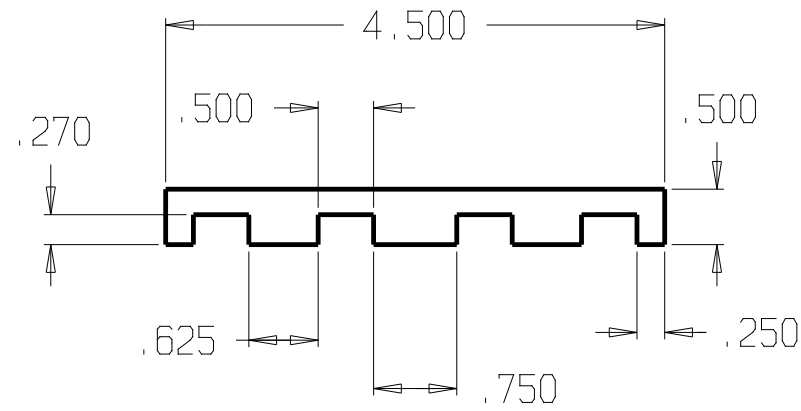

DON-JO MFG. INC.

DESIGNER

D.R.

SIZE

A

DATE:

8/18/15

PART NO.

HS-080

REV

SCALE

RELEASE DATE

WEIGHT

SHEET

| REVISIONS | | | |
|-----------|-----|-----------|------------|
| ZONE | REV | FINISHES: | GAUGE: |
| | | PC | 13ga. .090 |

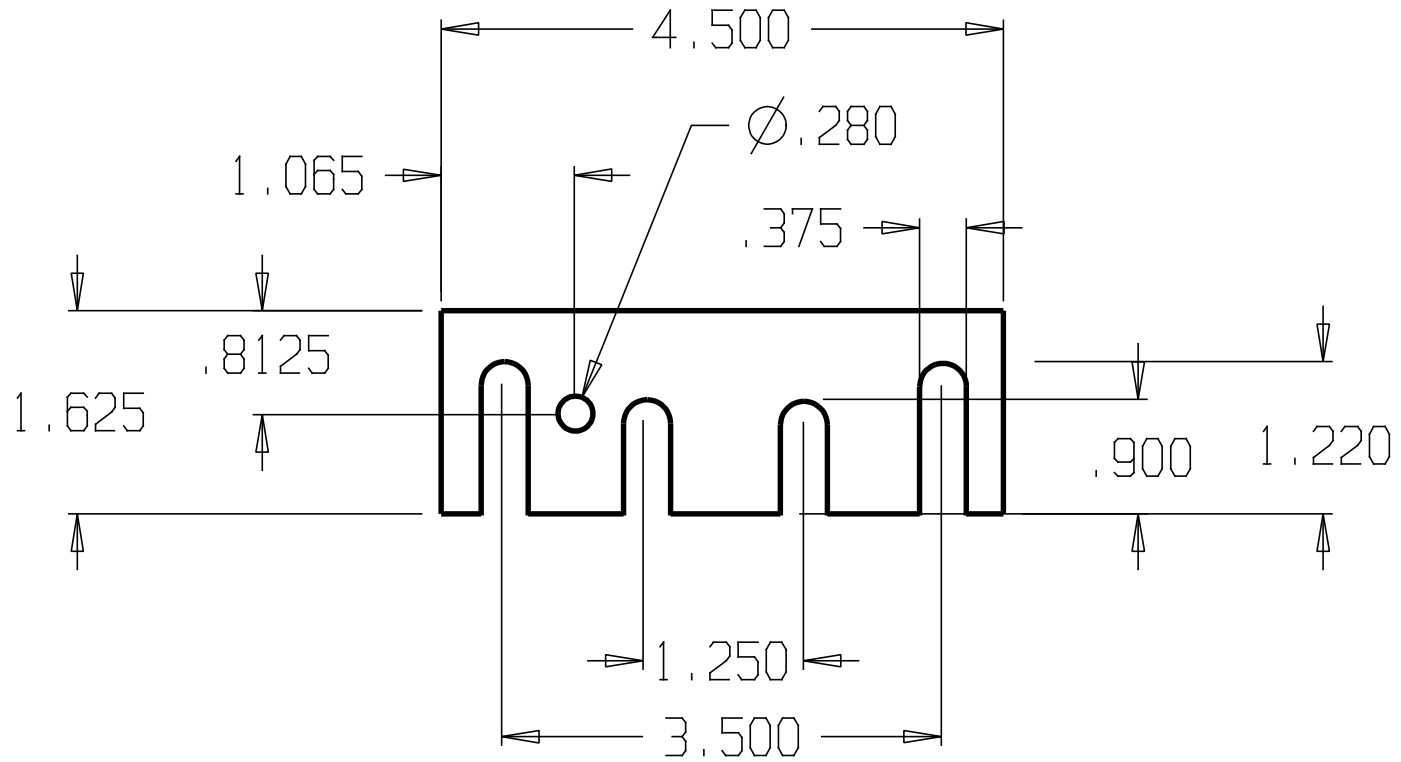

DON-JO MFG. INC.

| | | | | |
|----------|-------|--------------|----------|-------|
| DESIGNER | SIZE | DATE: | PART NO. | REV |
| | A | 5/24/04 | HS-090 | |
| APPROVED | SCALE | RELEASE DATE | WEIGHT | SHEET |
| | | | | |

| | | |
|--------|----|-----|
| DWG NO | SY | REV |
|--------|----|-----|

| REVISIONS | | | |
|-----------|-----|------------|----------|
| ZONE | REV | FINISHES : | GALUGE : |
| | | BROWN | |

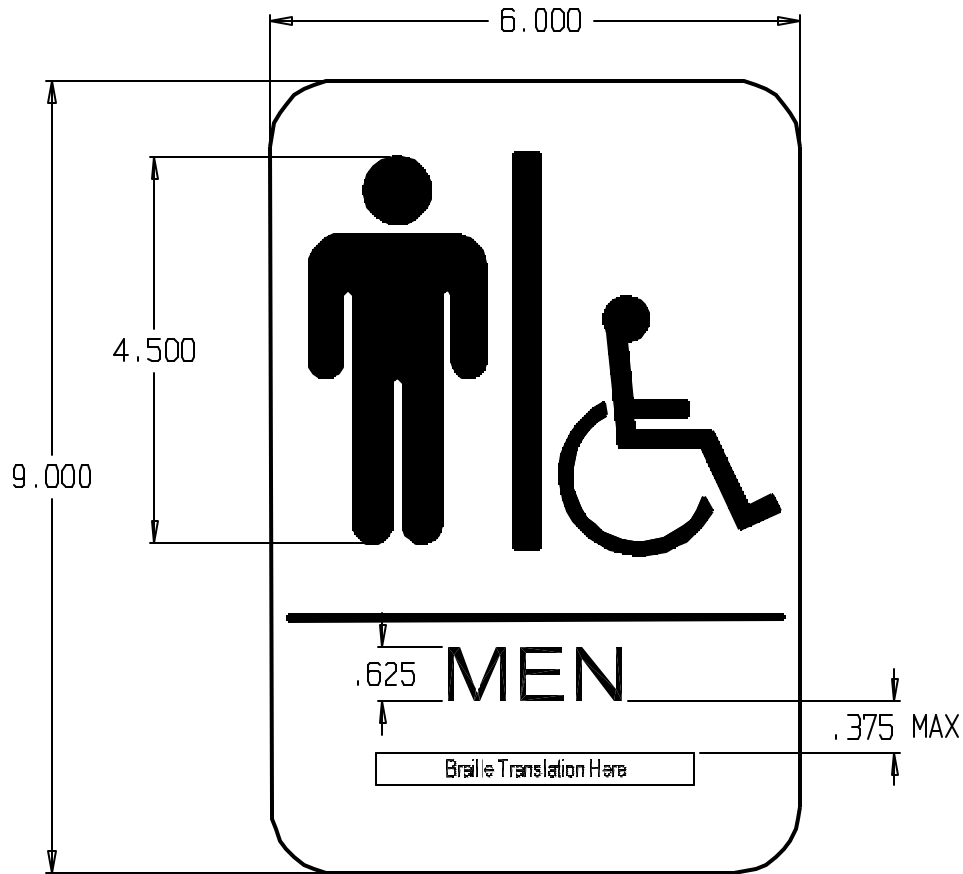

DON-JO MFG. INC.

| | | | | |
|----------|-------|--------------|------------|-------|
| DESIGNER | SIZE | DATE: | PART NO. | REV |
| | A | 5/4/04 | HS-9060-01 | |
| APPROVED | SCALE | RELEASE DATE | WEIGHT | SHEET |
| | | | | |

| REVISIONS | | | |
|-----------|-----|------------|----------|
| ZONE | REV | FINISHES : | GALUGE : |
| | | BROWN | |

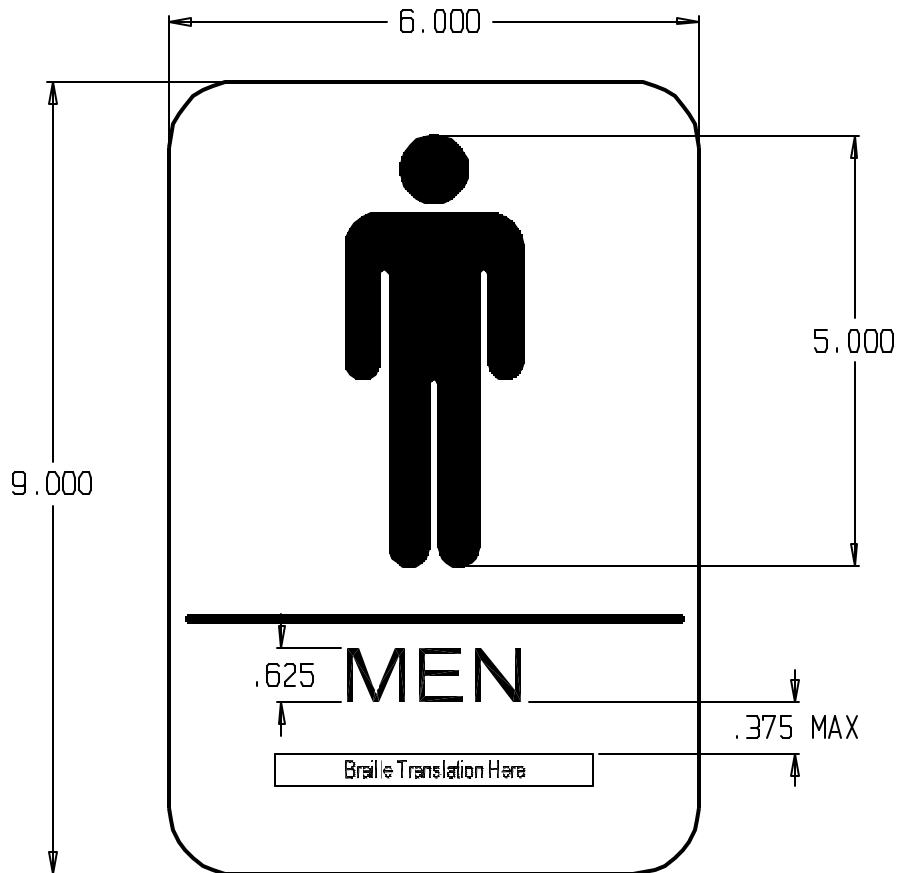

DON-JO MFG. INC.

| | | | | |
|----------|-------|--------------|------------|-------|
| DESIGNER | SIZE | DATE | PART NO. | REV |
| | A | 5/4/04 | HS-9060-02 | |
| APPROVED | SCALE | RELEASE DATE | WEIGHT | SHEET |
| | | | | |

REVISIONS

| | | | |
|------|-----|-----------------|--------|
| ZONE | REV | FINISHES: BROWN | GUAGE: |
|------|-----|-----------------|--------|

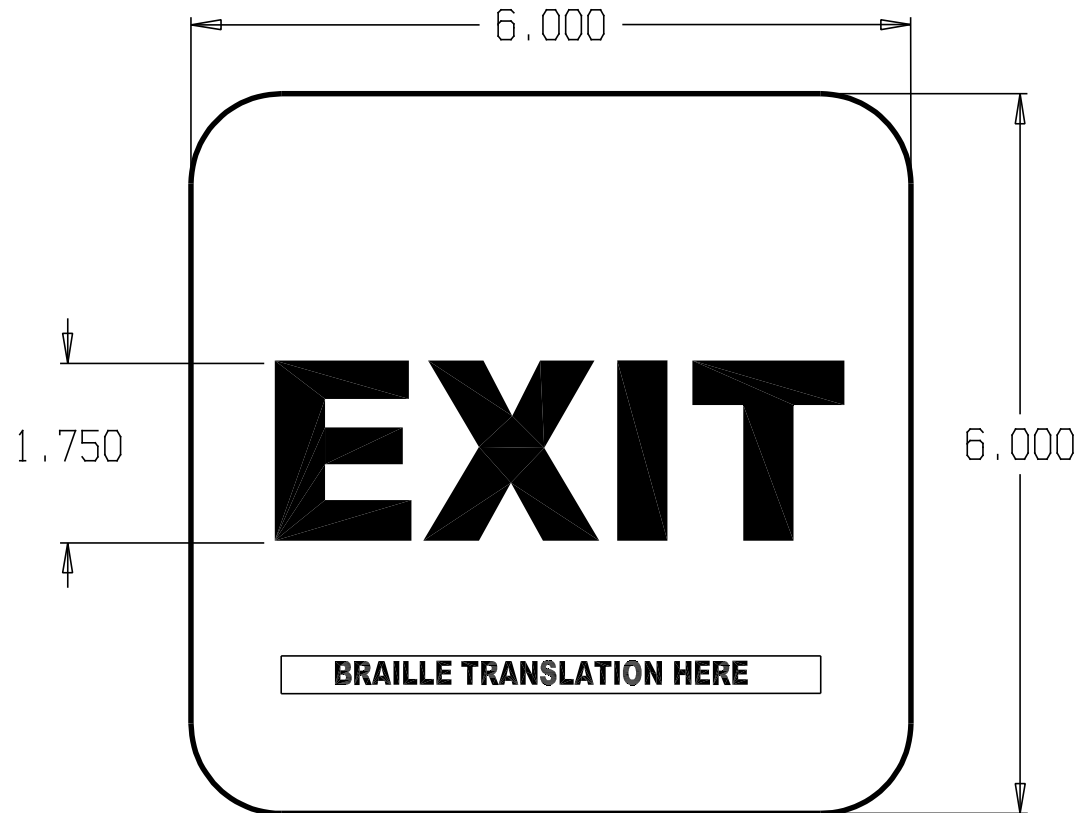

DON-JO MFG. INC.

| | | | | |
|----------|---------|---------------|---------------------|-------|
| DESIGNER | SIZE: A | DATE: 8/23/04 | PART NO. HS-9060-35 | REV |
| APPROVED | SCALE | RELEASE DATE | WEIGHT | SHEET |

| REVISIONS | | | |
|-----------|-----|------------|----------|
| ZONE | REV | FINISHES : | GALUGE : |
| | | BLUE | |

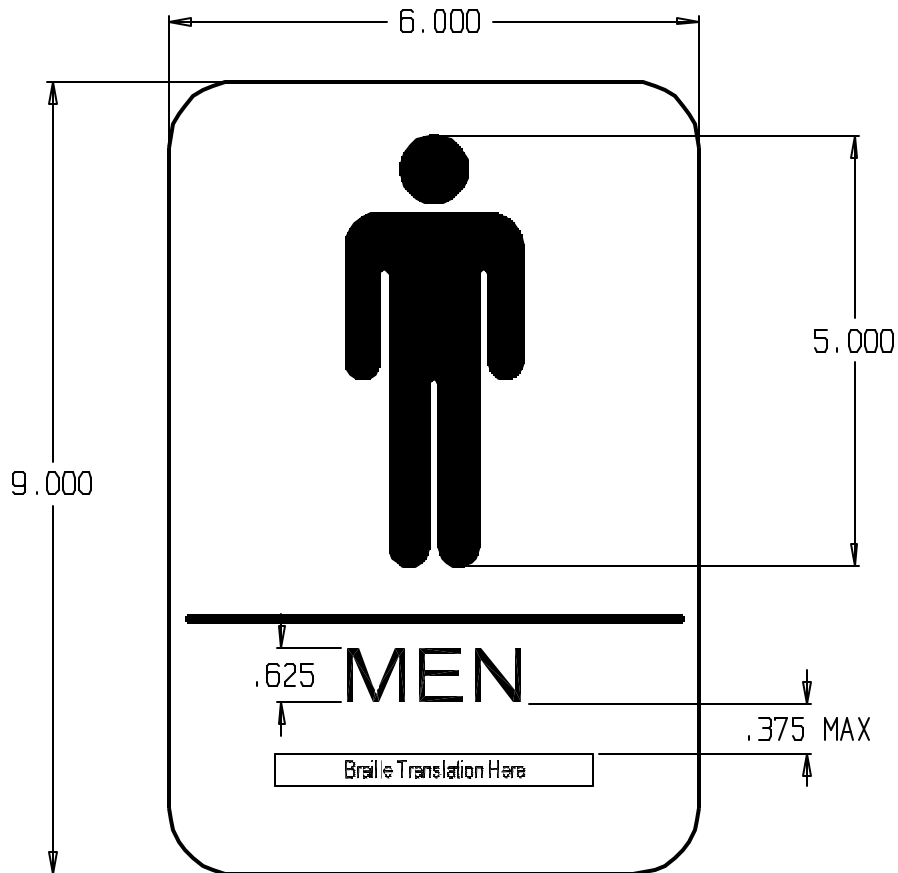

DON-JO MFG. INC.

| | | | | |
|----------|-------|--------------|------------|-------|
| DESIGNER | SIZE | DATE | PART NO. | REV |
| | A | 5/4/04 | HS-9070-02 | |
| APPROVED | SCALE | RELEASE DATE | WEIGHT | SHEET |
| | | | | |

REVISIONS

| | | | |
|------|-----|-----------|--------|
| ZONE | REV | FINISHES: | GUAGE: |
| | | BLUE | |

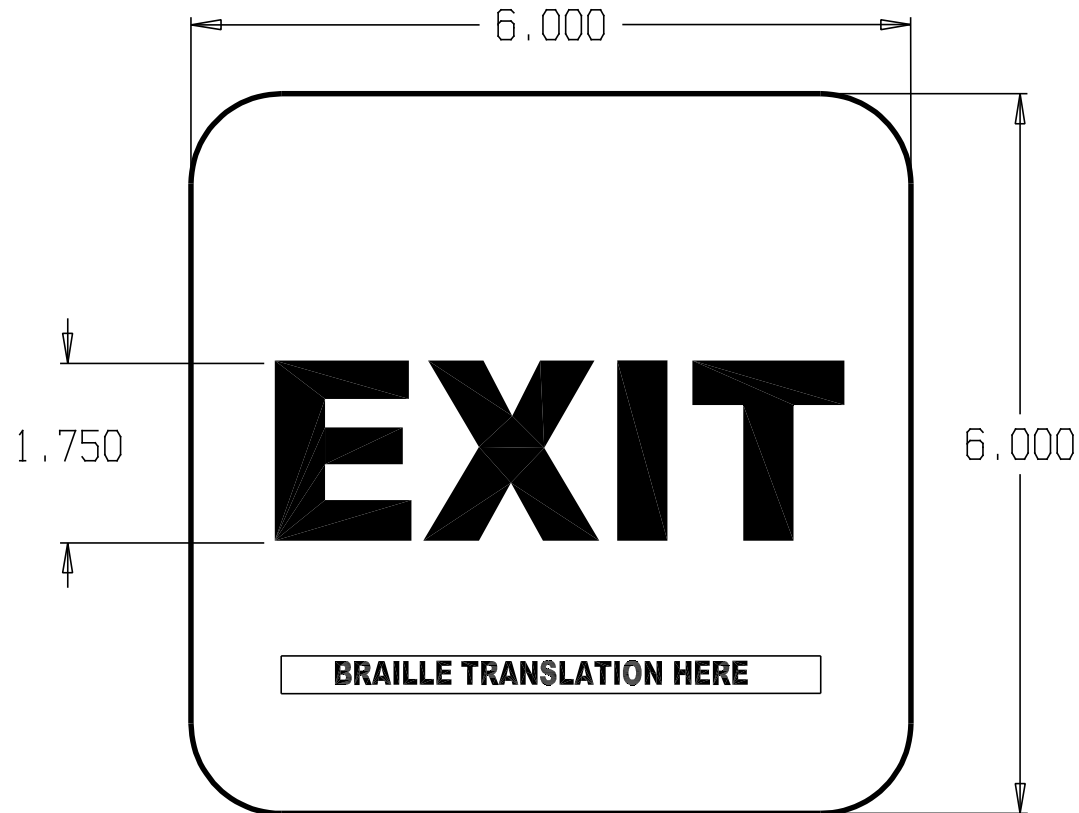

DON-JO MFG. INC.

| | | | | |
|----------|-------|--------------|------------|-------|
| DESIGNER | SIZE | DATE: | PART NO. | REV |
| | A | 8/23/04 | HS-9070-35 | |
| APPROVED | SCALE | RELEASE DATE | WEIGHT | SHEET |
| | | | | |

| REVISIONS | | | |
|-----------|-----|-----------|--------|
| ZONE | REV | FINISHES: | GAUGE: |
| | | PC | 1/4" |

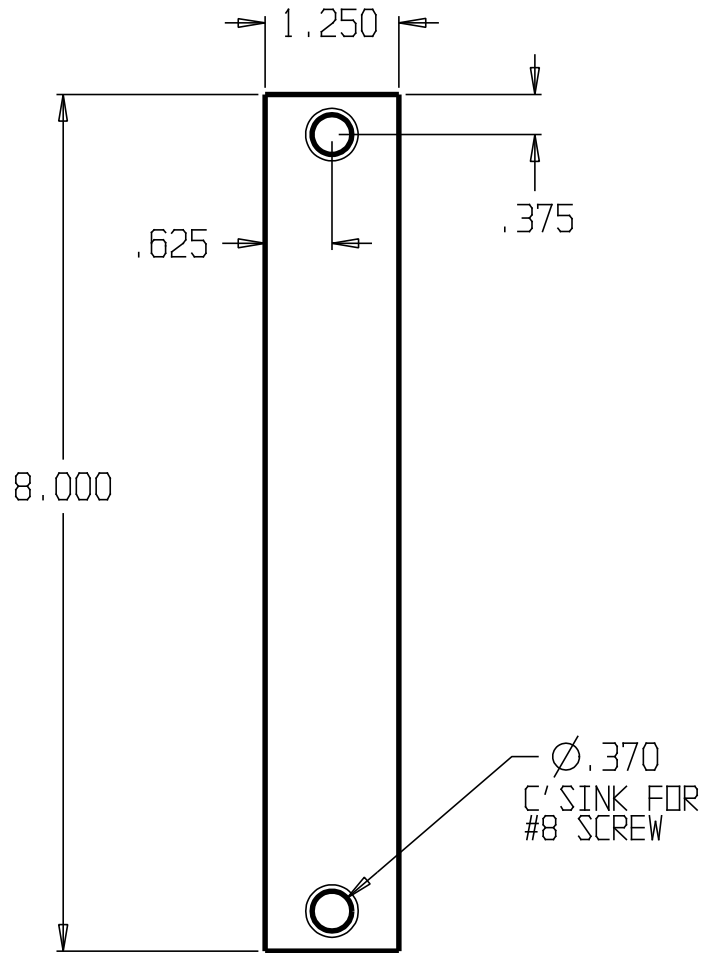

DON-JO MFG. INC.

| | | | | |
|----------|-------|--------------|----------|-------|
| DESIGNER | SIZE | DATE: | PART NO. | REV |
| | A | 5/13/04 | LW-86 | |
| APPROVED | SCALE | RELEASE DATE | WEIGHT | SHEET |
| | | | | |

REVISIONS

| ZONE | REV |
|------|-----|
| | |

FINISHES: DU & SL

GALUGE: 13ga. .095

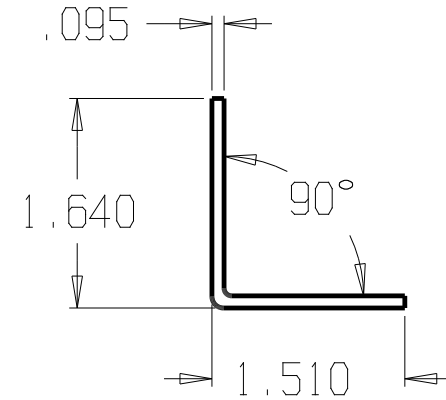
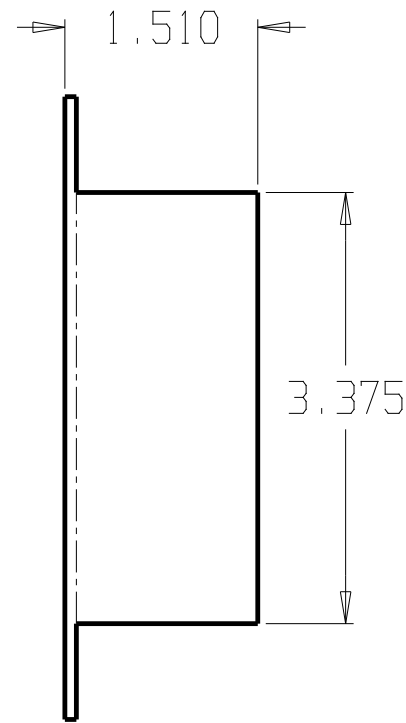
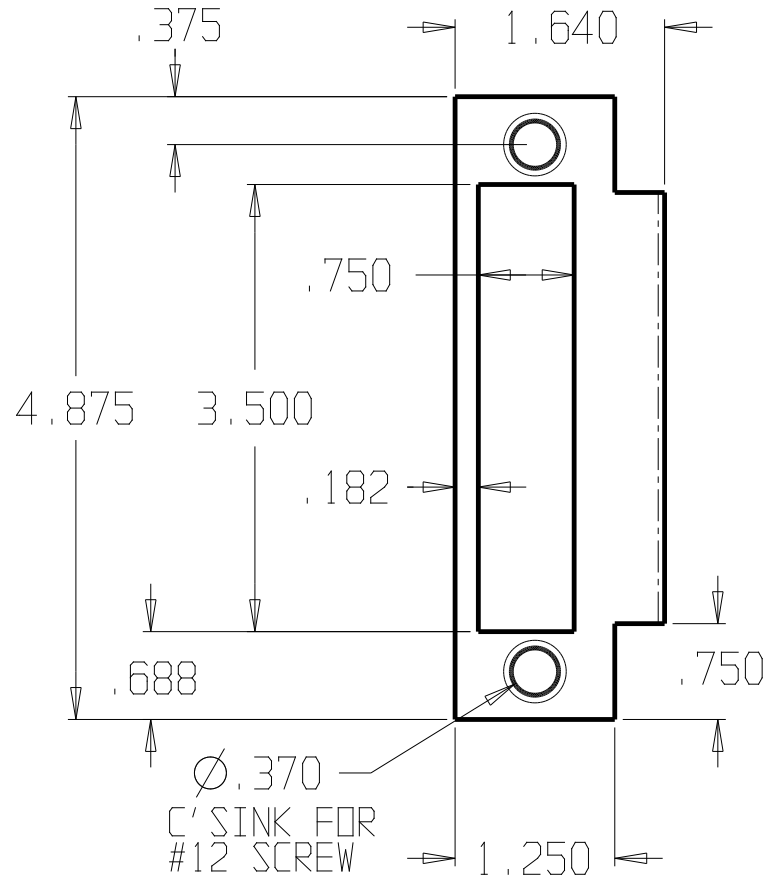

| | |
|-------------------------|--|
| DON-JO MFG. INC. | |
| DESIGNER | |
| APPROVED | |

| | | | |
|-------|--------------|----------|-------|
| SIZE | DATE: | PART NO. | REV |
| A | 6/26/14 | MAF-261 | |
| SCALE | RELEASE DATE | WEIGHT | SHEET |
| | | | |

| REVISIONS | | | |
|-----------|-----|-----------|------------|
| ZONE | REV | FINISHES: | GALIGE: |
| | | PC | 16ga. .060 |

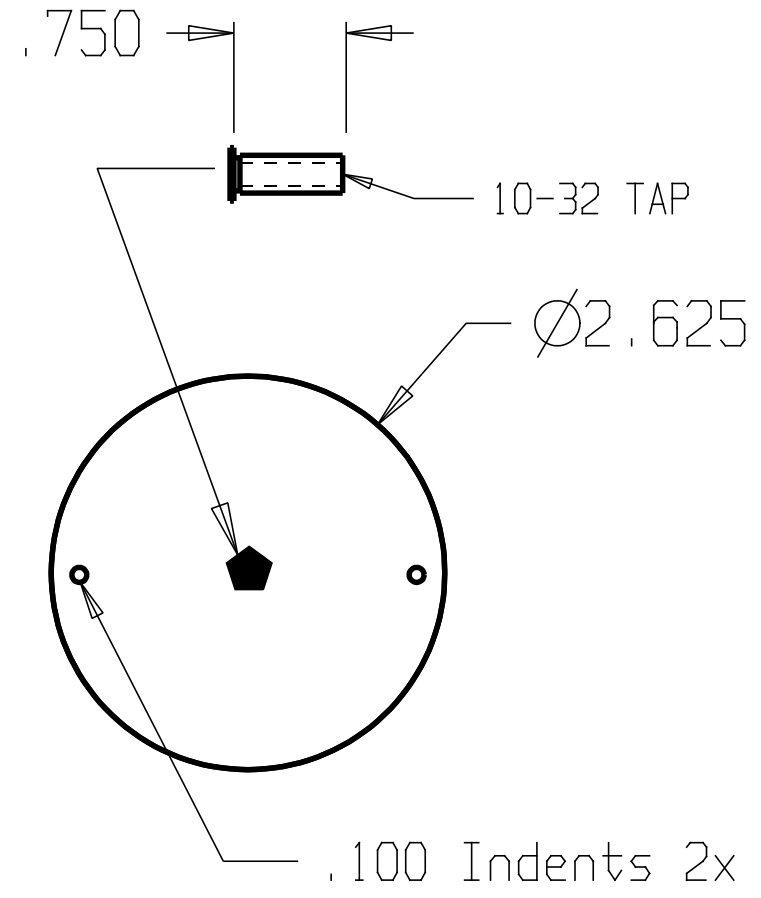
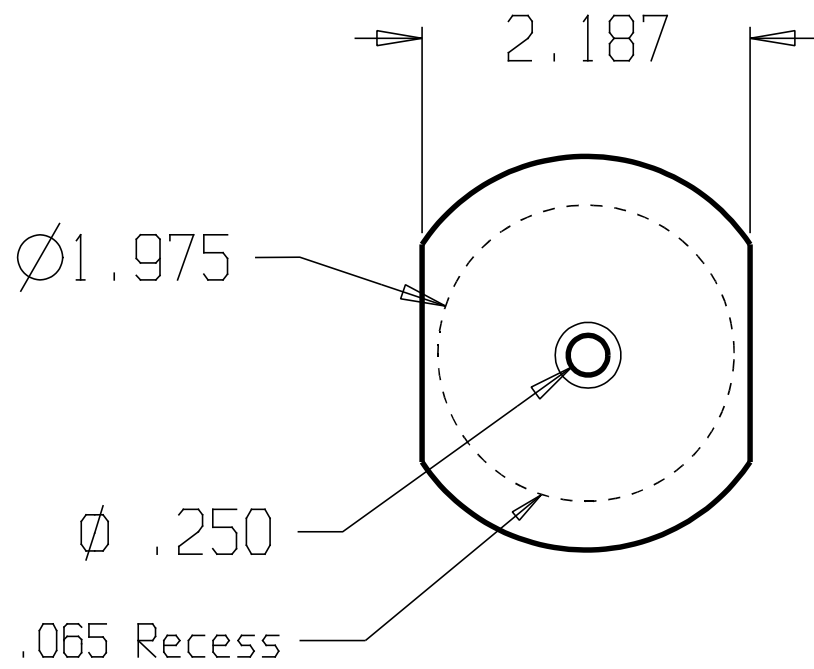

| | | | | | | | |
|-------------------------|--|-------|--------------|----------------|-------|----------|-----|
| DON-JO MFG. INC. | | | | SIZE | DATE: | PART NO. | REV |
| DESIGNER | | A | 5/3/04 | PDF-161 | | | |
| APPROVED | | SCALE | RELEASE DATE | WEIGHT | SHEET | | |

| REVISIONS | | | |
|-----------|-----|-----------|------------|
| ZONE | REV | FINISHES: | GAUGE: |
| | | PC | 10ga. .134 |

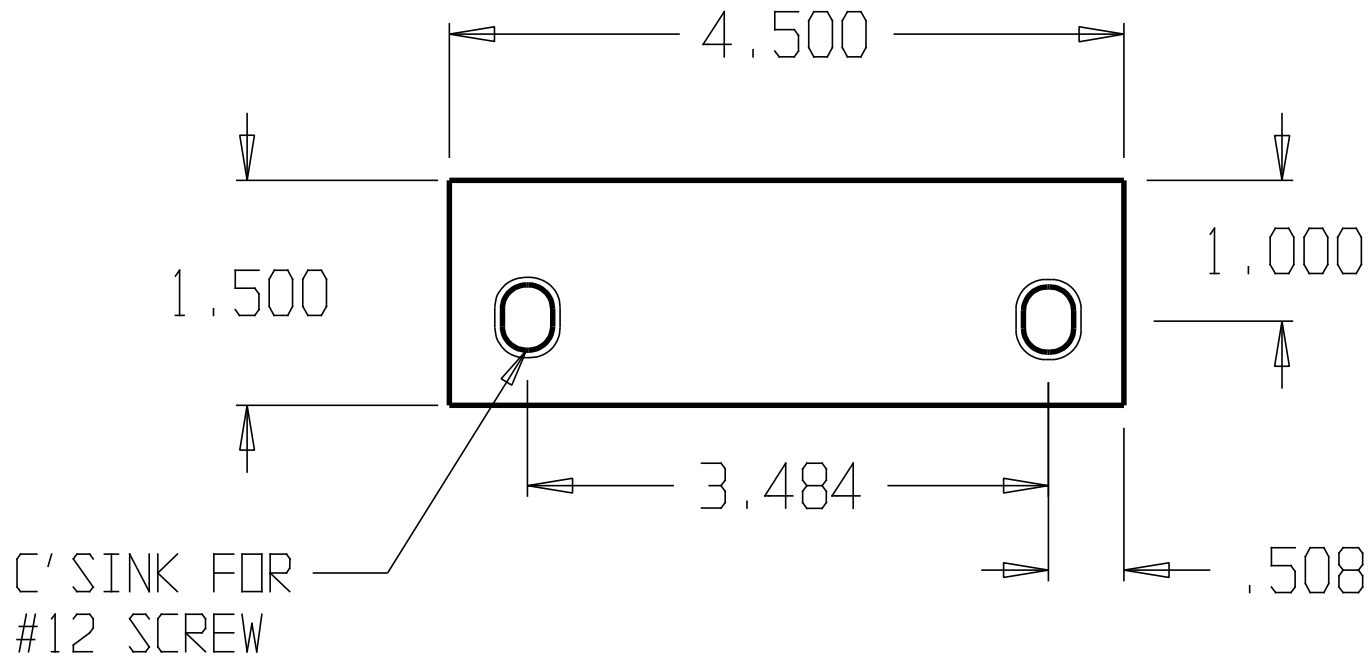

| | | | | | | | |
|------------------|--|-------|--------------|--------|-------|----------|-----|
| DON-JO MFG. INC. | | | | SIZE | DATE: | PART NO. | REV |
| DESIGNER | | A | 5/19/04 | SHF-45 | | | |
| APPROVED | | SCALE | RELEASE DATE | WEIGHT | SHEET | | |

DWG NO

SH

REV

REVISIONS

ZONE

REV

FINISHES:

PC

GALIGE:

10ga. .134

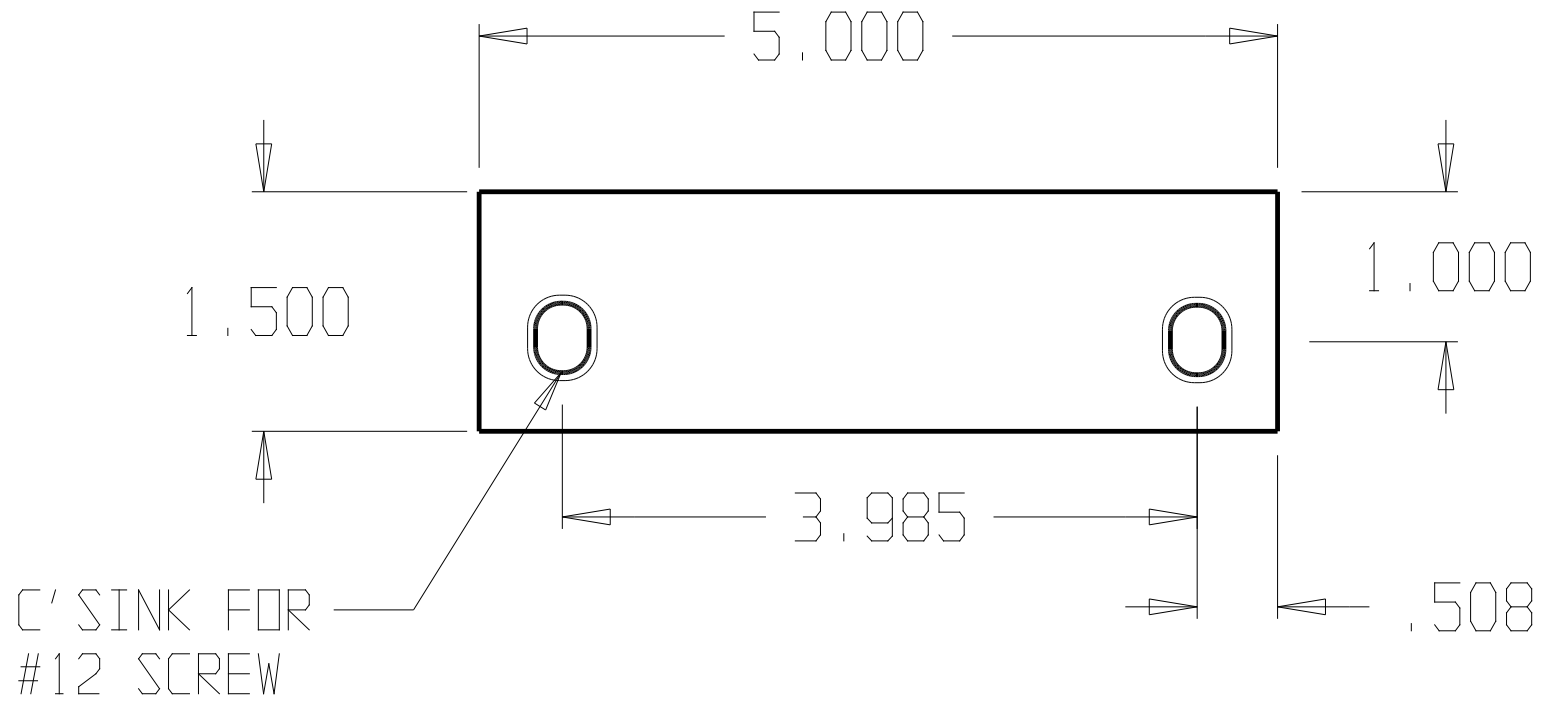

DON-JO MFG. INC.

DESIGNER

SIZE

DATE:

PART NO.

REV

A

5/19/04

SHF-50

APPROVED

SCALE

RELEASE DATE

WEIGHT

SHEET

REVISIONS

| ZONE | REV |
|------|-----|
| | |

FINISHES: DU & SL

GALIGE: 13ga .095

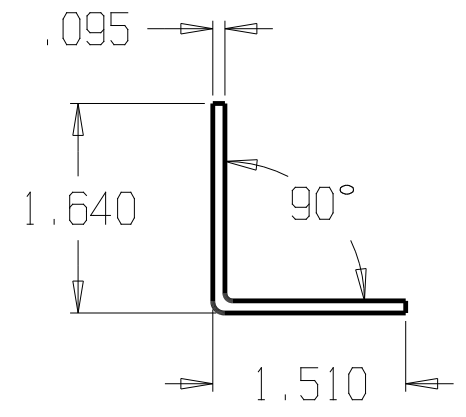
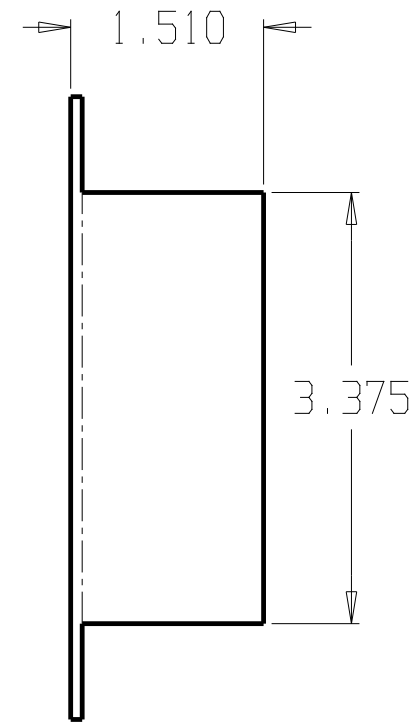
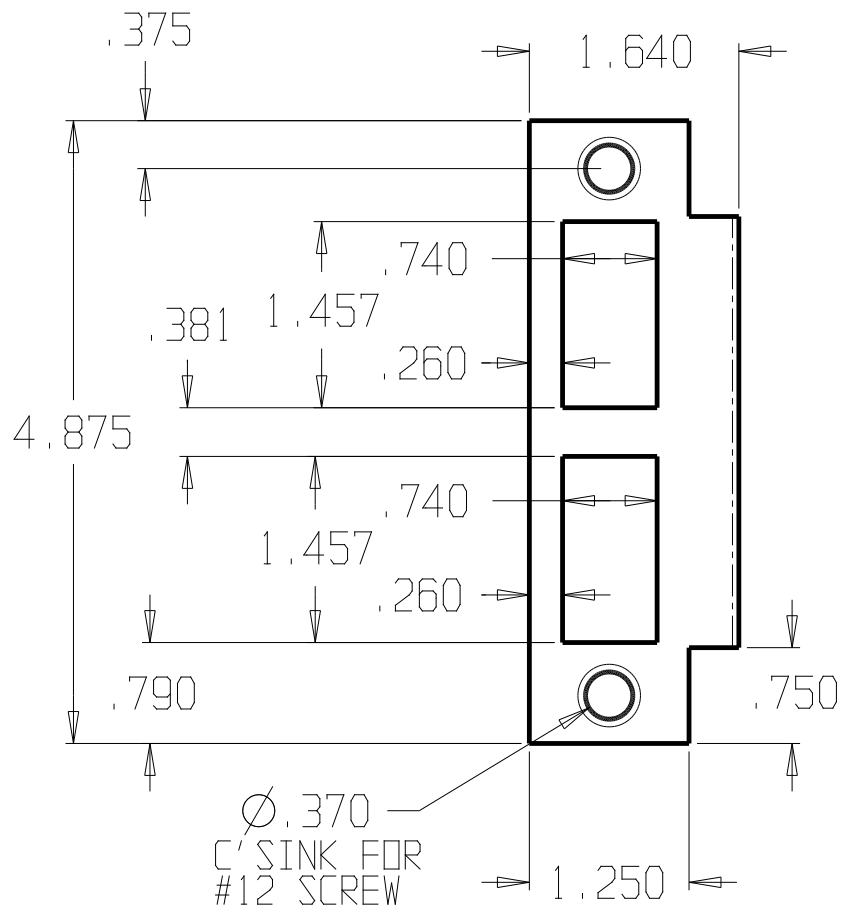

DON-JO MFG. INC.

DESIGNER: _____

APPROVED: _____

| | | | |
|--------------|---------------------|-------------------|--------------|
| SIZE: A | DATE: 6/26/14 | PART NO. SMAF-261 | REV: _____ |
| SCALE: _____ | RELEASE DATE: _____ | WEIGHT: _____ | SHEET: _____ |

| REVISIONS | | | |
|-----------|-----|-----------|--------|
| ZONE | REV | FINISHES: | GUAGE: |
| | | PC | 1/4" |

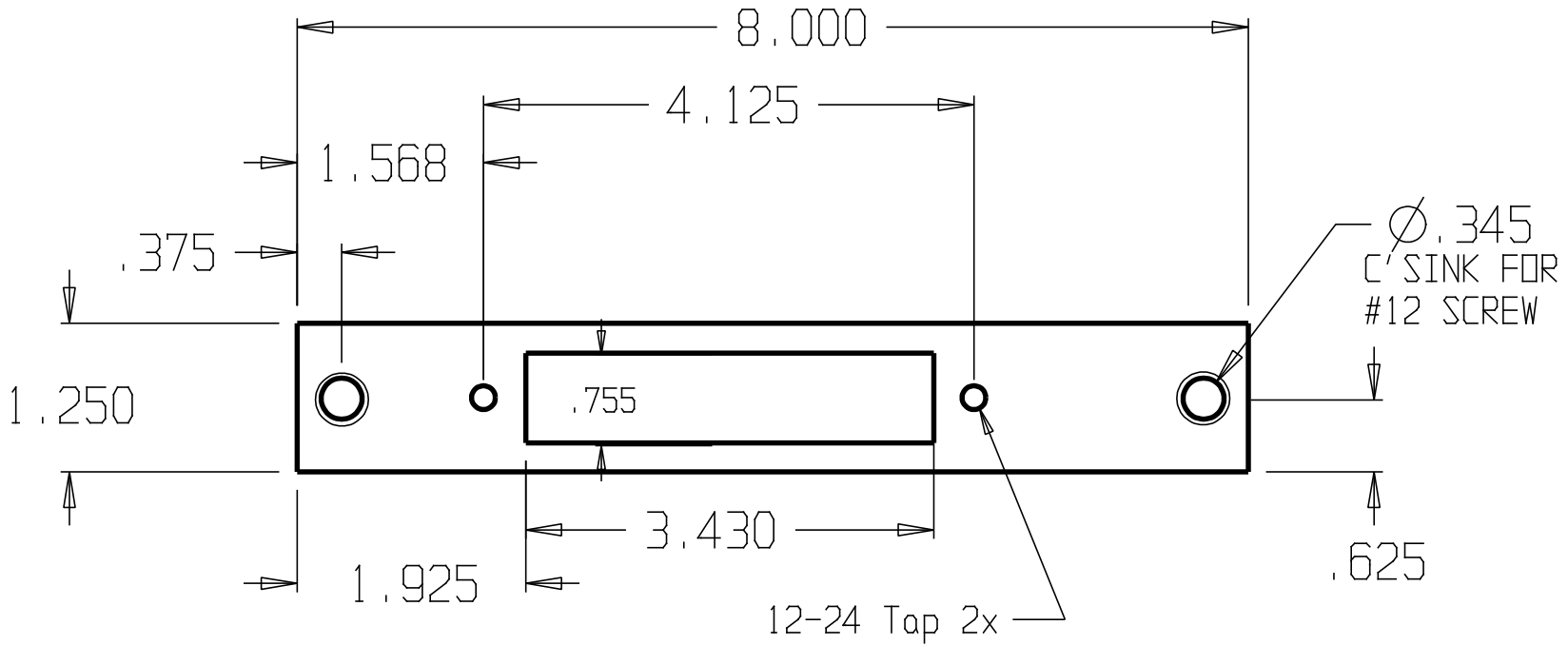

DON-JO MFG. INC.

| | | | | |
|----------|---------|--------------|-----------------|-------|
| DESIGNER | SIZE: A | DATE: 6/3/04 | PART NO. ST-386 | REV |
| APPROVED | SCALE | RELEASE DATE | WEIGHT | SHEET |

| REVISIONS | | | |
|-----------|-----|-------------|------------|
| ZONE | REV | FINISHES: | GAUGE: |
| | | ZINC PLATED | 13ga. .090 |

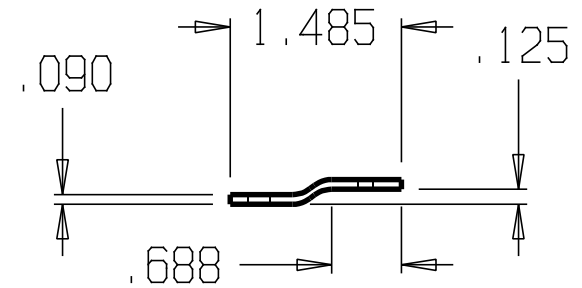
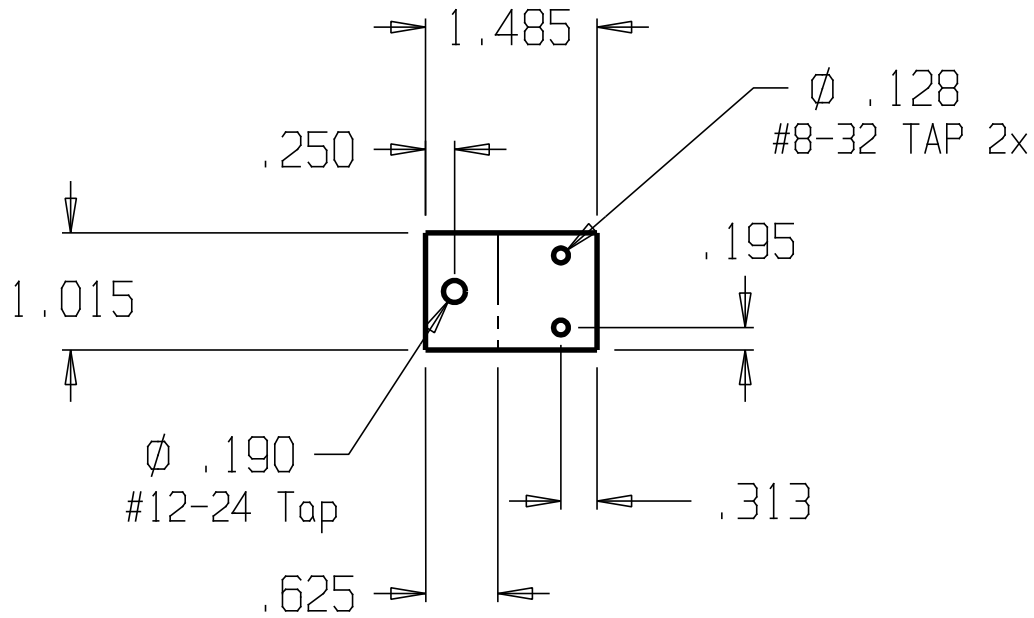

DON-JO MFG. INC.

DESIGNER
APPROVED

| | | | |
|-----------|-----------------|--------------------|-------|
| SIZE A | DATE: 6/3/04 | PART NO. TB-215 | REV |
| SCALE | RELEASE DATE | WEIGHT | SHEET |

| REVISIONS | | | |
|-----------|-----|------------|--------|
| ZONE | REV | FINISHES: | GAUGE: |
| | | PRIME COAT | |

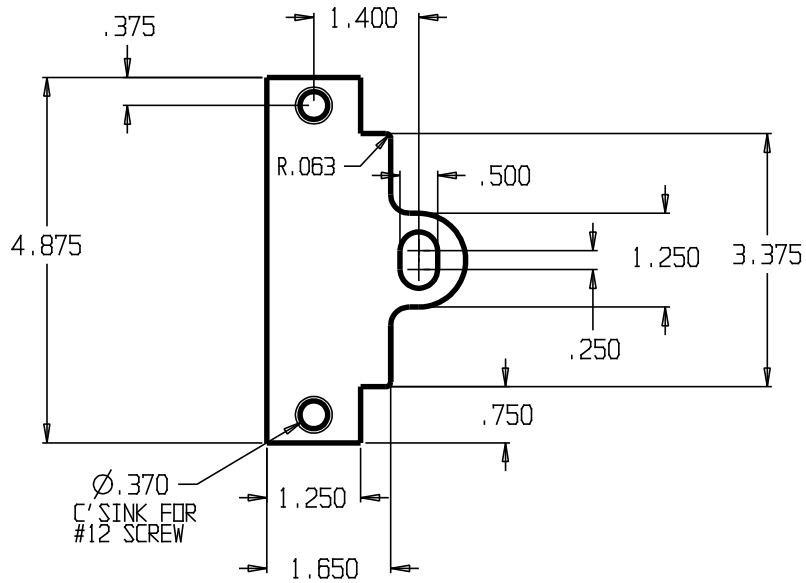

13ga. .090

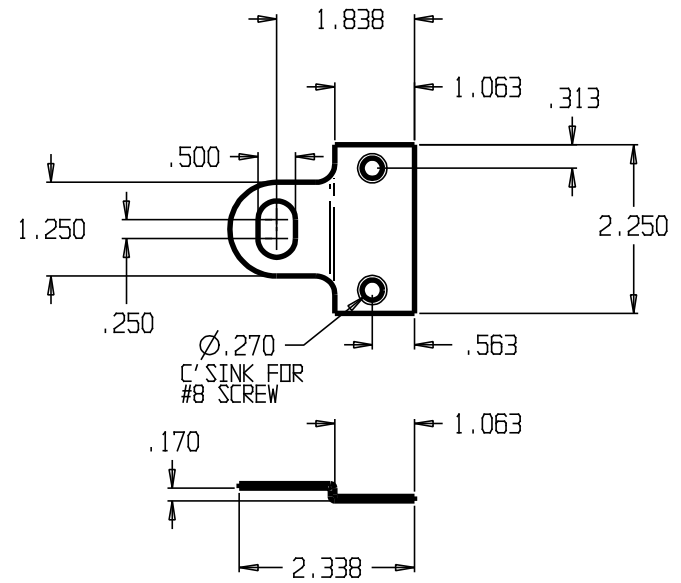

16ga. .062

DON-JO MFG. INC.

| | | | | |
|----------|--------------|--------------|---------------|-----|
| DESIGNER | SCALE | DATE: 3/3/05 | PART NO. TL-1 | REV |
| APPROVED | RELEASE DATE | WEIGHT | SHEET | |

| REVISIONS | | |
|-----------|-----|------------|
| ZONE | REV | FINISHES: |
| | | PRIME COAT |
| | | GAUGE: |

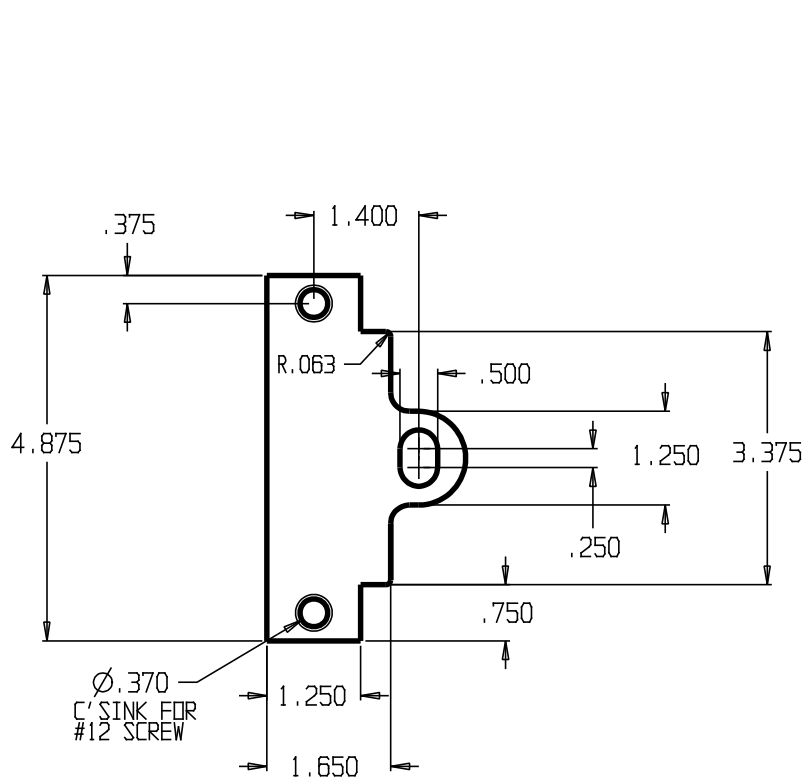

13ga. .090

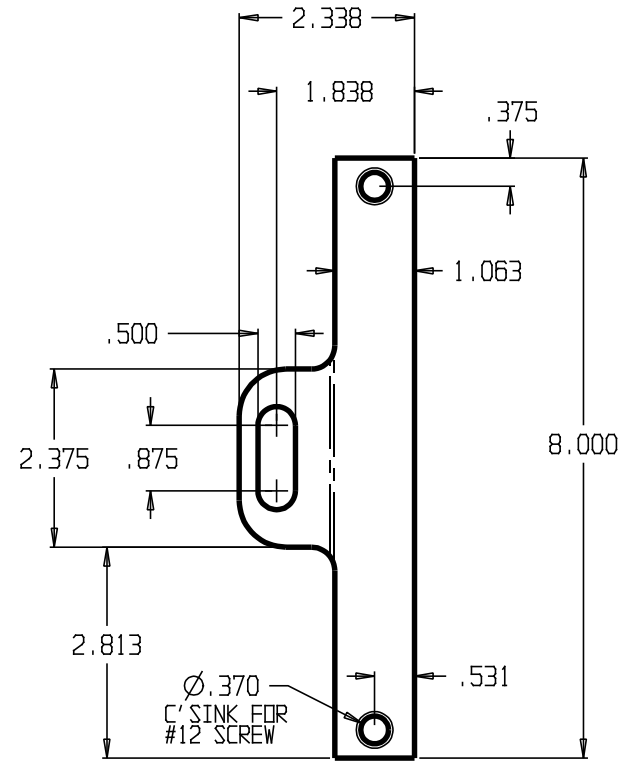

16ga. .062

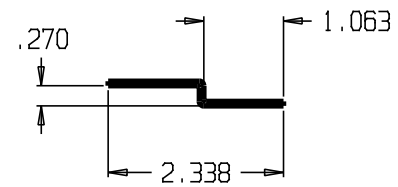

DON-JO MFG. INC.

| | |
|----------|--|
| DESIGNER | |
| APPROVED | |

| | | | |
|-----------|------------------|------------------|-------|
| SIZE A | DATE: 3/21/05 | PART NO. TL-2 | REV |
| SCALE | RELEASE DATE | WEIGHT | SHEET |

| REVISIONS | | | |
|-----------|-----|------------|---------|
| ZONE | REV | FINISHES : | GUAGE : |
| | | PRIME COAT | |

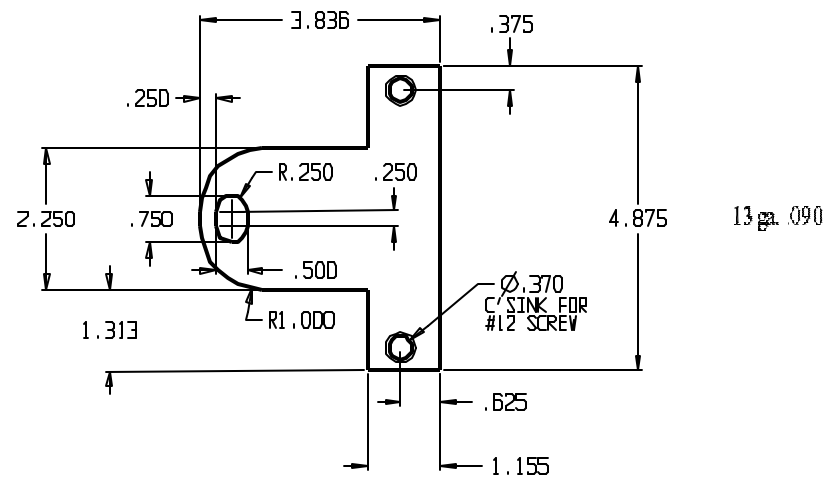
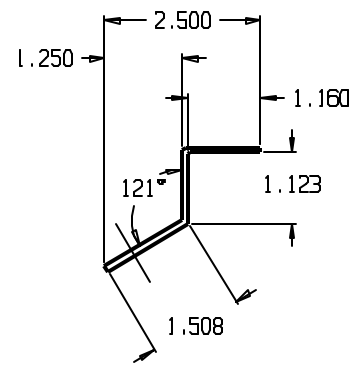

13 ga .090

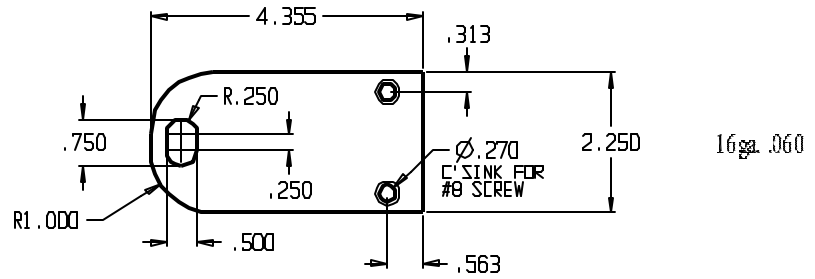
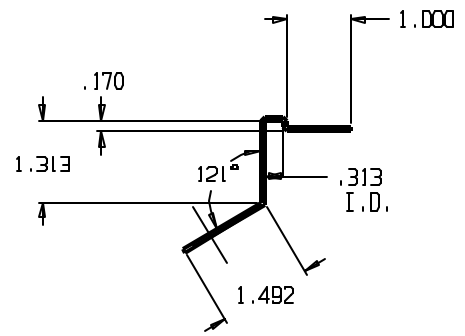

16 ga .060

DON-JO MFG. INC.

| | | | | |
|----------|-------|--------------|----------|-------|
| DESIGNER | SIZE | DATE | PART NO. | REV |
| D.R. | A | 4/19/10 | TL-3 | |
| | SCALE | RELEASE DATE | WEIGHT | SHEET |

| REVISIONS | | | |
|-----------|-----|-----------|------------|
| ZONE | REV | FINISHES: | GUAGE: |
| | | 652 | 10ga. .135 |

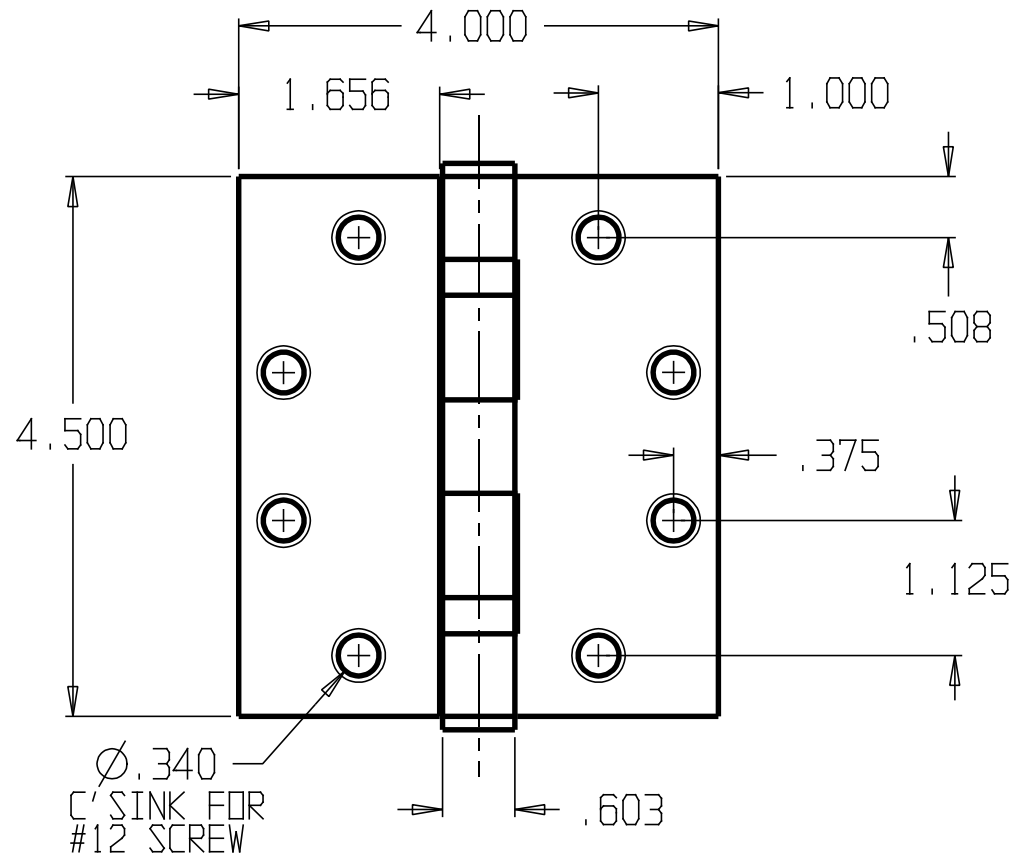

DON-JO MFG. INC.

DESIGNER
APPROVED

SIZE: A
DATE: 1/12/05

PART NO. BB-74540
REV

SCALE
RELEASE DATE
WEIGHT
SHEET

| REVISIONS | | |
|-----------|-----|---|
| ZONE | REV | FINISHES: 600, 632, 633, 639, 640, 651, 652 |
| | | GAUGE: 10ga. .135 |

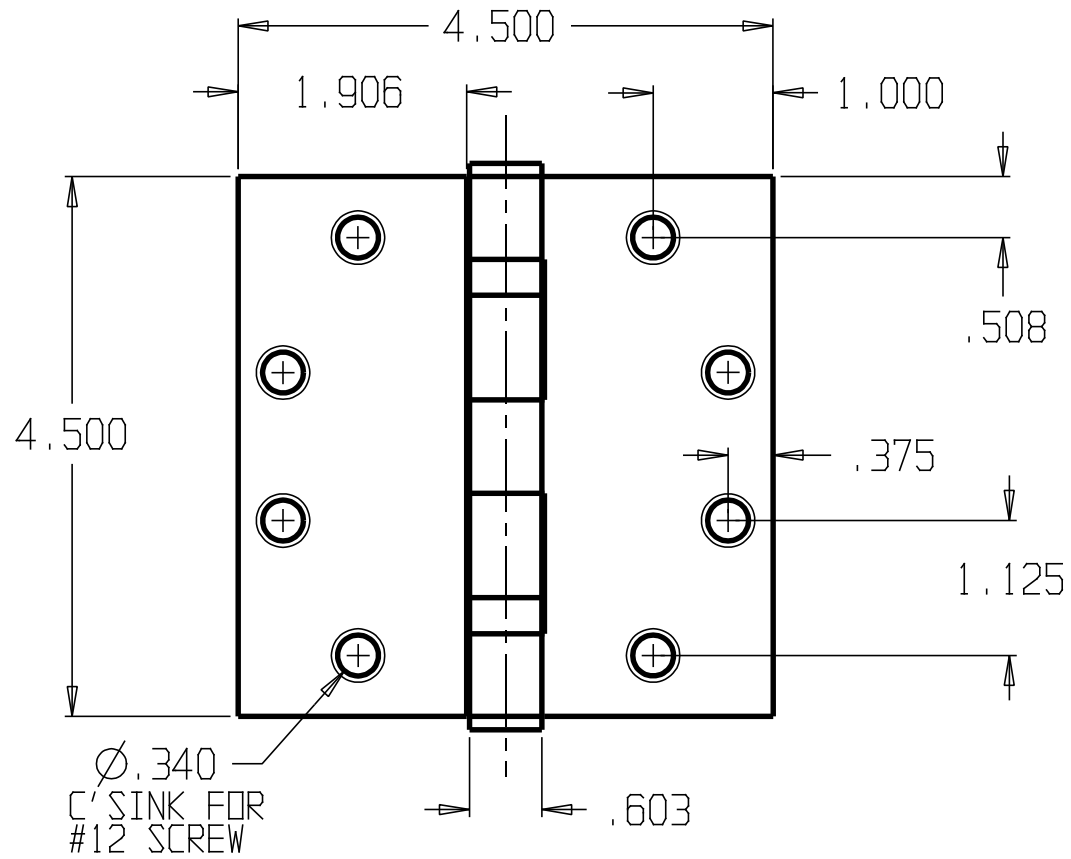

DON-JO MFG. INC.

| | | | | |
|----------|---------|---------------|-------------------|-------|
| DESIGNER | SIZE: A | DATE: 1/12/05 | PART NO. BB-74545 | REV |
| APPROVED | SCALE | RELEASE DATE | WEIGHT | SHEET |

| REVISIONS | | | |
|-----------|-----|-----------|------------|
| ZONE | REV | FINISHES: | GUAGE: |
| | | 626 | 10ga. .135 |

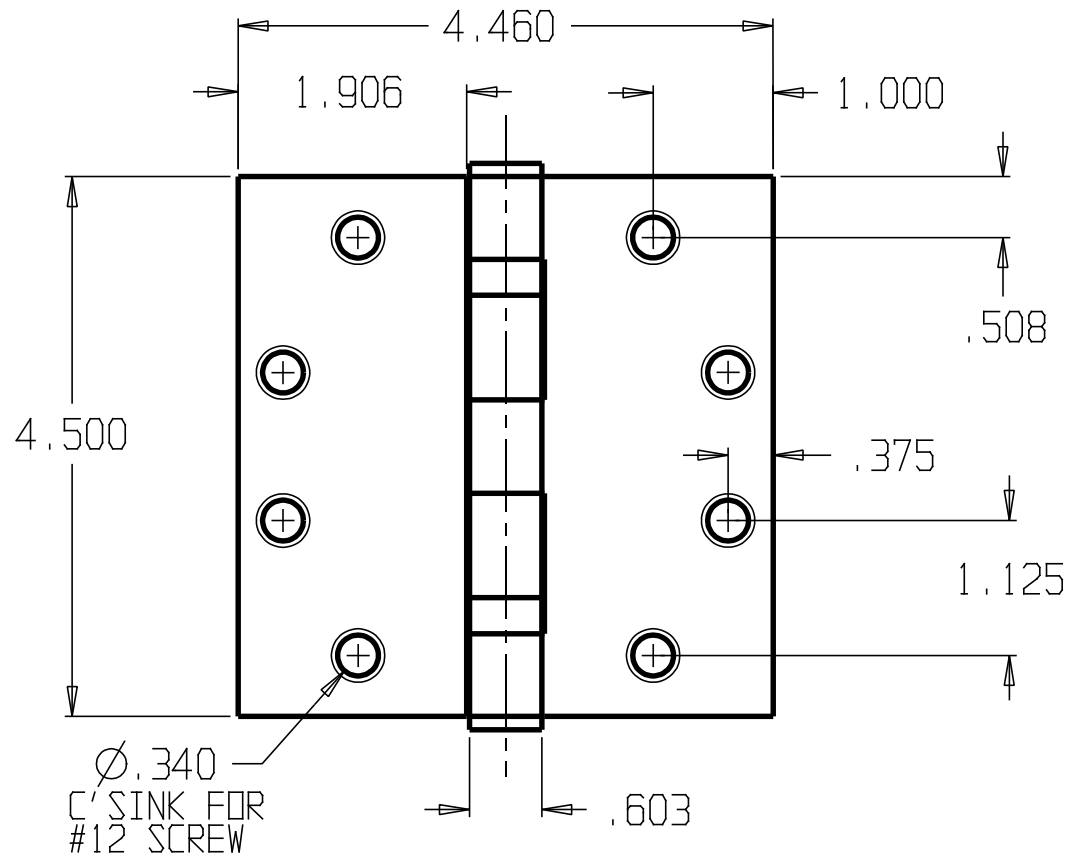

DON-JO MFG. INC.

| | | | | |
|----------|-----------|------------------|----------------------|-------|
| DESIGNER | SIZE A | DATE: 1/12/05 | PART NO. BB-84545 | REV |
| APPROVED | SCALE | RELEASE DATE | WEIGHT | SHEET |

| REVISIONS | | | |
|-----------|-----|-----------|------------|
| ZONE | REV | FINISHES: | GUAGE: |
| | | 630 | 10ga. .135 |

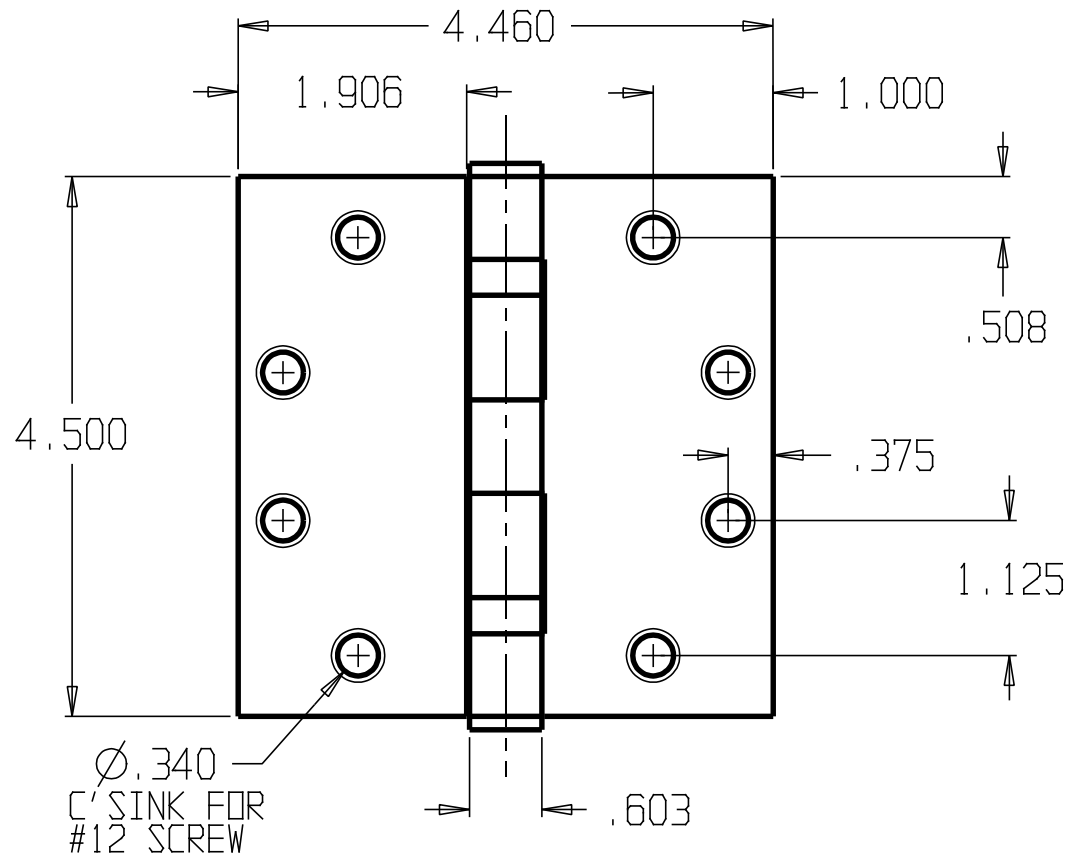

DON-JO MFG. INC.

| | | | | |
|----------|-----------|------------------|----------------------|-------|
| DESIGNER | SIZE A | DATE: 1/12/05 | PART NO. BB-94545 | REV |
| APPROVED | SCALE | RELEASE DATE | WEIGHT | SHEET |

| REVISIONS | | | |
|-----------|-----|-----------|---------|
| ZONE | REV | FINISHES: | GALUGE: |
| | | | |

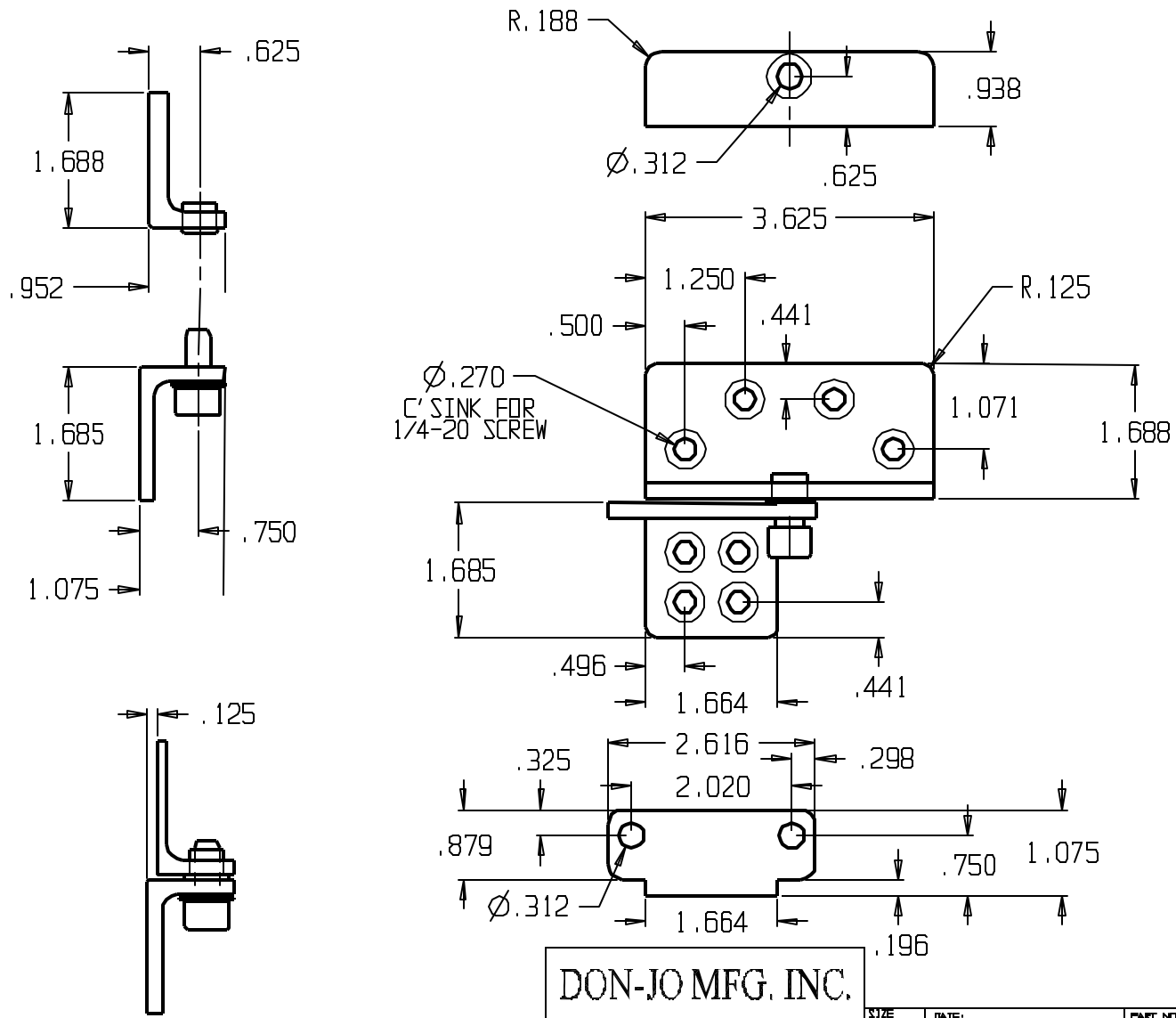

DON-JO MFG. INC.

| | | | |
|----------|--------------|----------|-------|
| DESIGNER | DATE | PART NO. | REV |
| D.R. | 4/7/10 | HRP-1 | |
| SCALE | RELEASE DATE | WEIGHT | SHEET |

| REVISIONS | | | |
|-----------|-----|------------|----------|
| ZONE | REV | FINISHES : | GALUGE : |
| | | | |

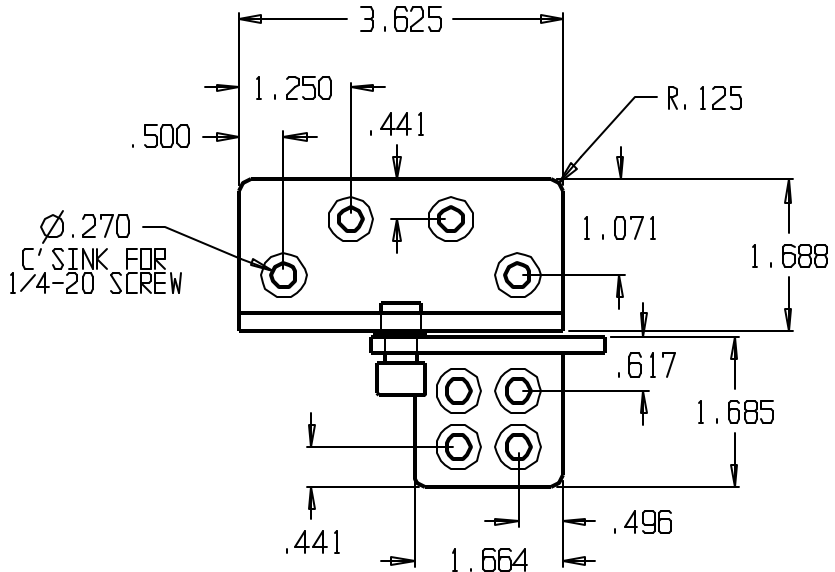
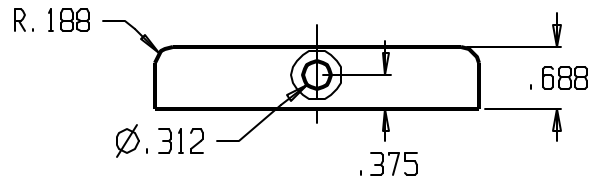
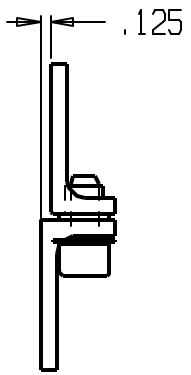
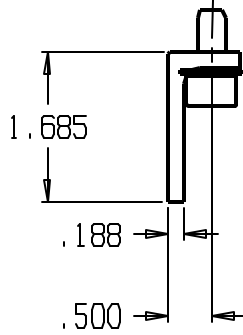
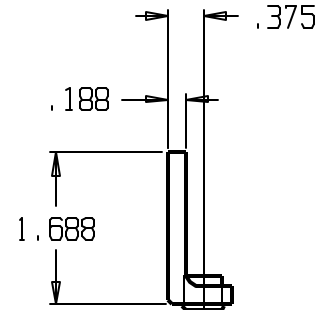

Ø.270
C' SINK FOR
1/4-20 SCREW

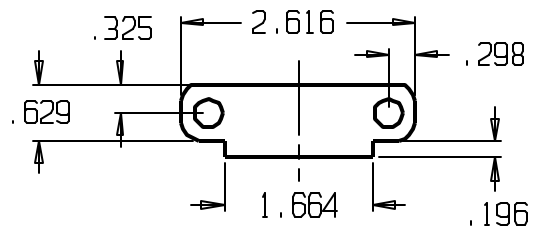

DON-JO MFG. INC.

| | | | | |
|------------------|-----------|----------------|-------------------|-------|
| DESIGNER D.R. | SIZE A | DATE 4/7/10 | PART NO. HRP-2 | REV |
| | SCALE | RELEASE DATE | WEIGHT | SHEET |

| REVISIONS | | | |
|-----------|-----|-----------|-----------|
| ZONE | REV | FINISHES: | GAUGE: |
| | | 652 | 7ga. .180 |

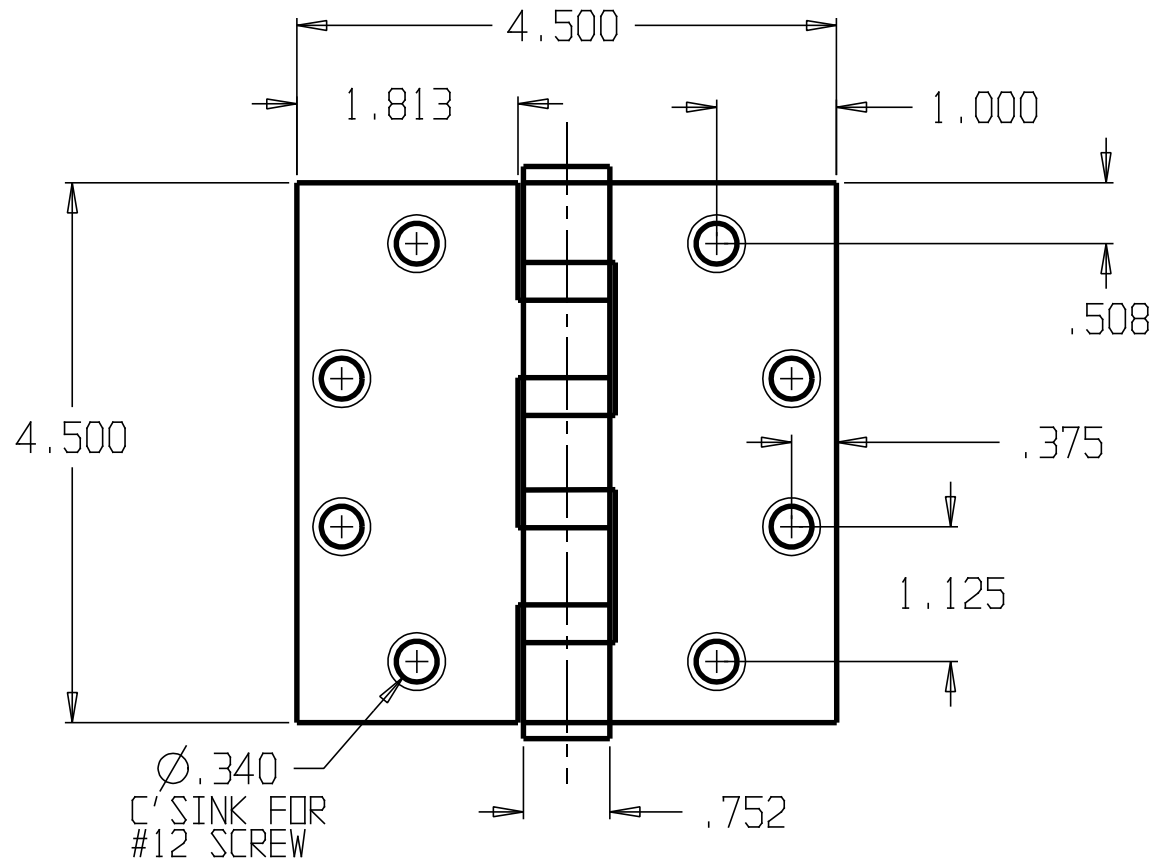

| | | | | | | | |
|------------------|--|-------|--------------|------------|-------|----------|-----|
| DON-JO MFG. INC. | | | | SIZE | DATE: | PART NO. | REV |
| DESIGNER | | A | 1/14/05 | HWBB-74545 | | | |
| APPROVED | | SCALE | RELEASE DATE | WEIGHT | SHEET | | |

| REVISIONS | | |
|-----------|-----|-------------|
| ZONE | REV | FINISHES: |
| | | 652 |
| | | GUAGE: .190 |

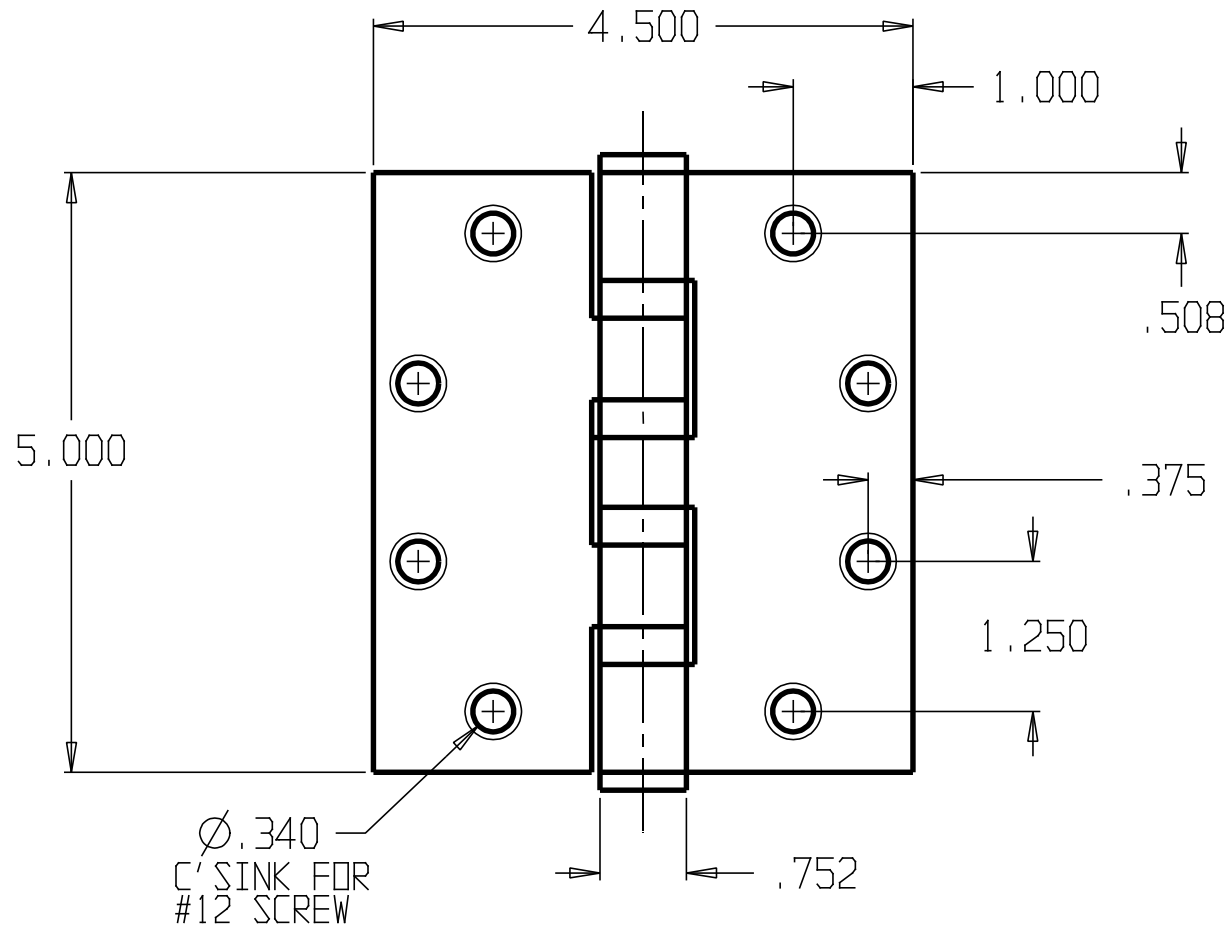

DON-JO MFG. INC.

| | | | | |
|----------|--------|---------------|---------------------|-------|
| DESIGNER | SIZE A | DATE: 1/14/05 | PART NO. HWBB-75045 | REV |
| APPROVED | SCALE | RELEASE DATE | WEIGHT | SHEET |

| REVISIONS | | | |
|-----------|-----|-----------|-----------|
| ZONE | REV | FINISHES: | GAUGE: |
| | | 626 | 7ga. .180 |

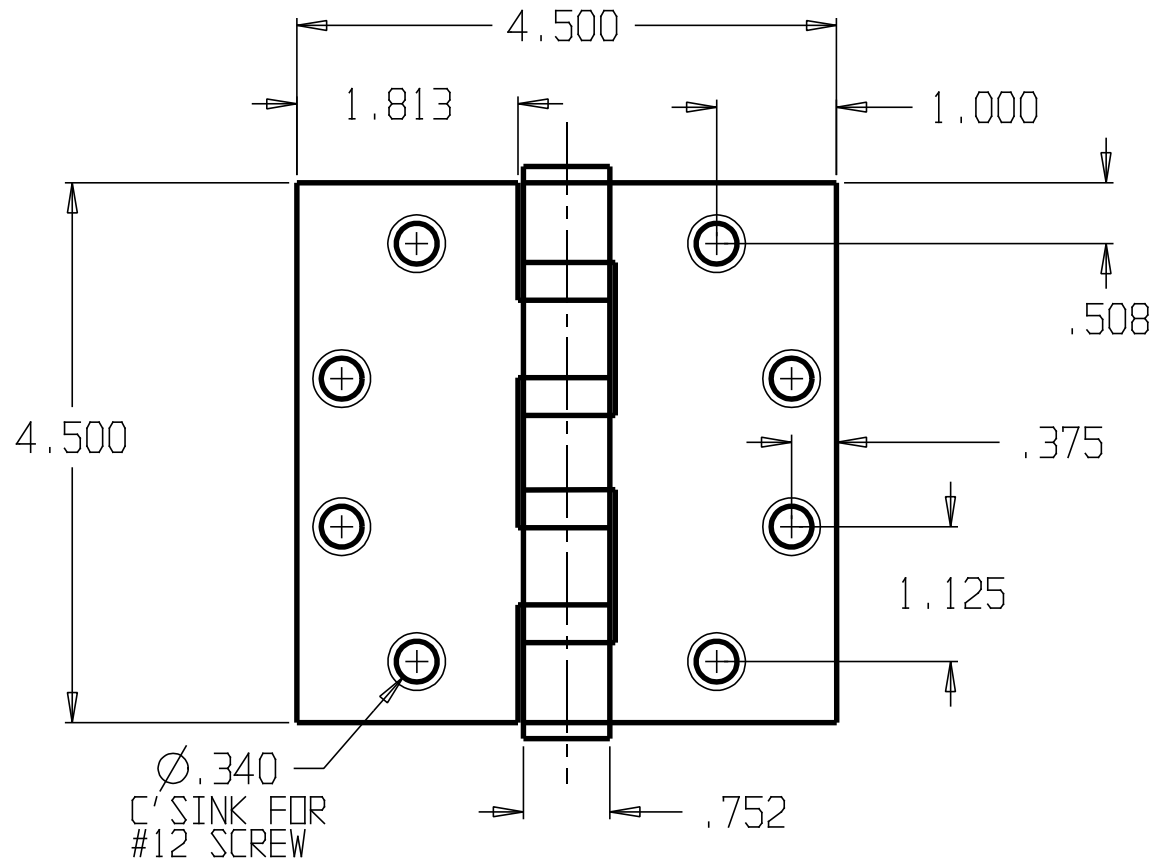

| | | | | | |
|------------------|--|-------|--------------|------------|-------|
| DON-JO MFG. INC. | | SIZE | DATE: | PART NO. | REV |
| DESIGNER | | A | 1/14/05 | HWBB-84545 | |
| APPROVED | | SCALE | RELEASE DATE | WEIGHT | SHEET |

| REVISIONS | | | |
|-----------|-----|-----------|------------|
| ZONE | REV | FINISHES: | GAUGE: |
| | | 652 | 10ga. .135 |

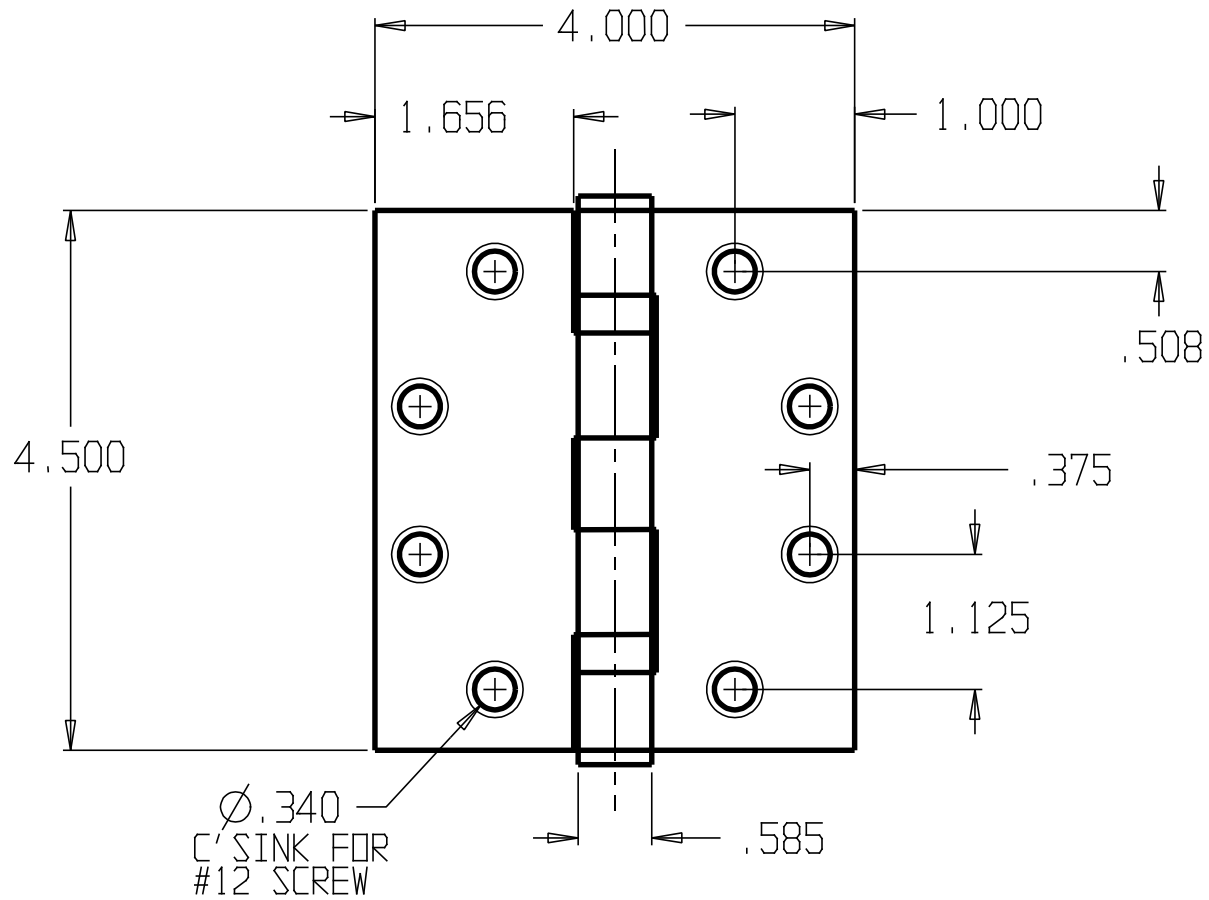

DON-JO MFG. INC.

| | | | | |
|----------|-----------|------------------|----------------------|-------|
| DESIGNER | SIZE A | DATE: 1/14/05 | PART NO. PB-74540 | REV |
| APPROVED | SCALE | RELEASE DATE | WEIGHT | SHEET |

| REVISIONS | | |
|-----------|-----|------------------------------|
| ZONE | REV | FINISHES: |
| | | 600, 632, 633, 639, 640, 652 |
| | | GAUGE: |
| | | 10ga. .135 |

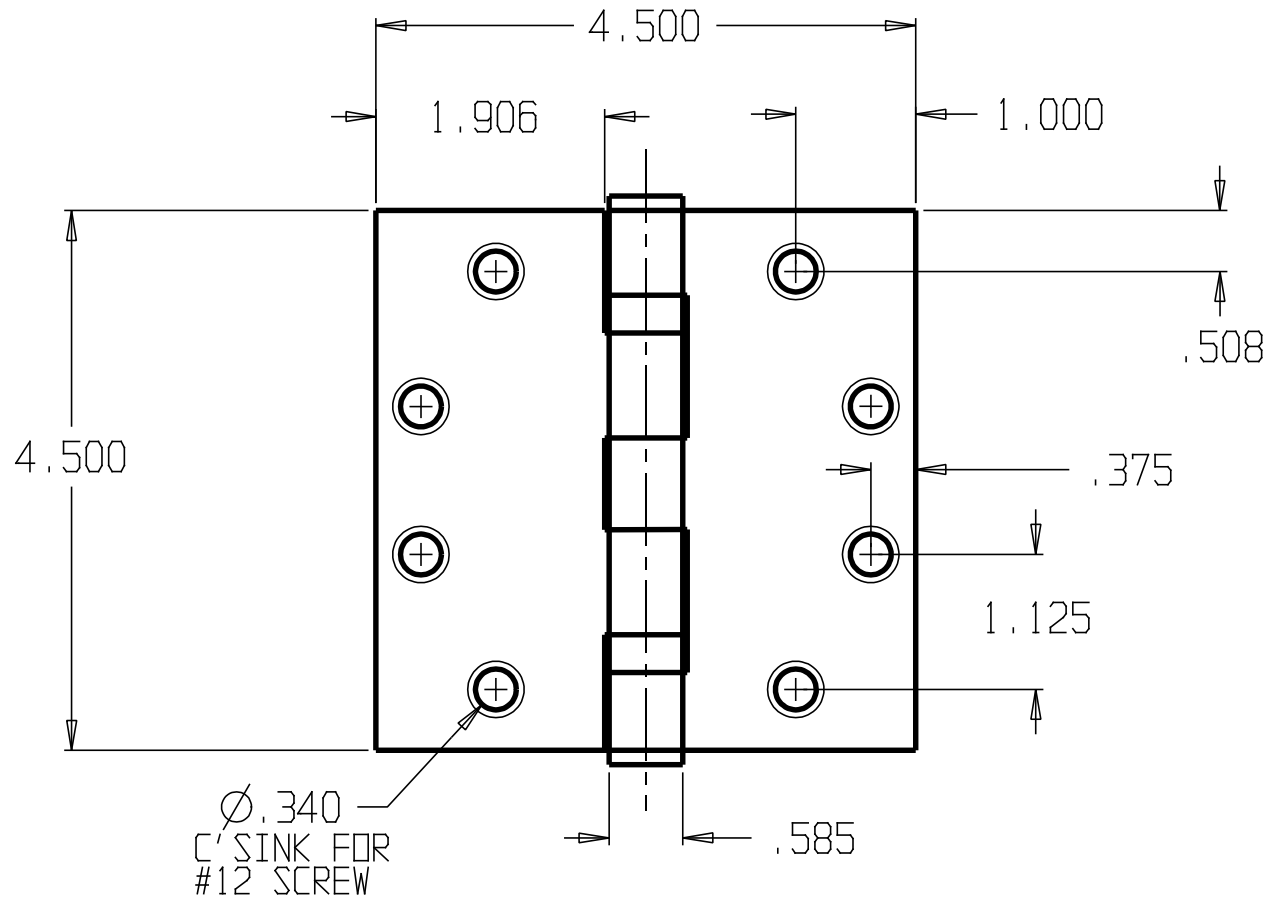

DON-JO MFG. INC.

| | | | | |
|----------|-----------|------------------|----------------------|-------|
| DESIGNER | SIZE A | DATE: 1/14/05 | PART NO. PB-74545 | REV |
| APPROVED | SCALE | RELEASE DATE | WEIGHT | SHEET |

| REVISIONS | | | |
|-----------|-----|-----------|------------|
| ZONE | REV | FINISHES: | GAUGE: |
| | | 630 | 10ga. .135 |

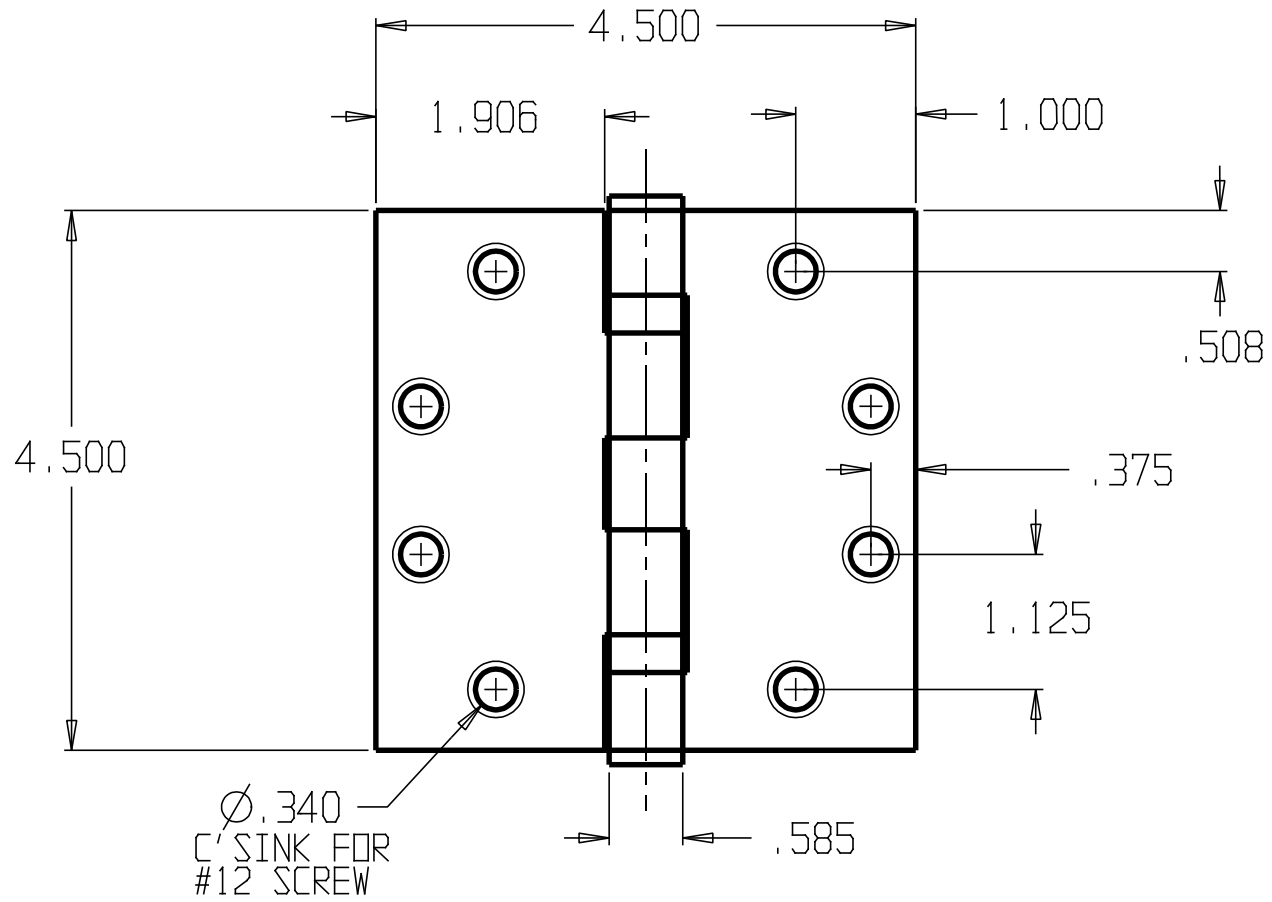

DON-JO MFG. INC.

| | | | | |
|----------|-----------|------------------|----------------------|-------|
| DESIGNER | SIZE A | DATE: 1/14/05 | PART NO. PB-94545 | REV |
| APPROVED | SCALE | RELEASE DATE | WEIGHT | SHEET |

| REVISIONS | | |
|-----------|-----|--|
| ZONE | REV | FINISHES: 632, 633, 638, 639, 640, 646, 651, 652 |
| | | GAUGE: .085 |

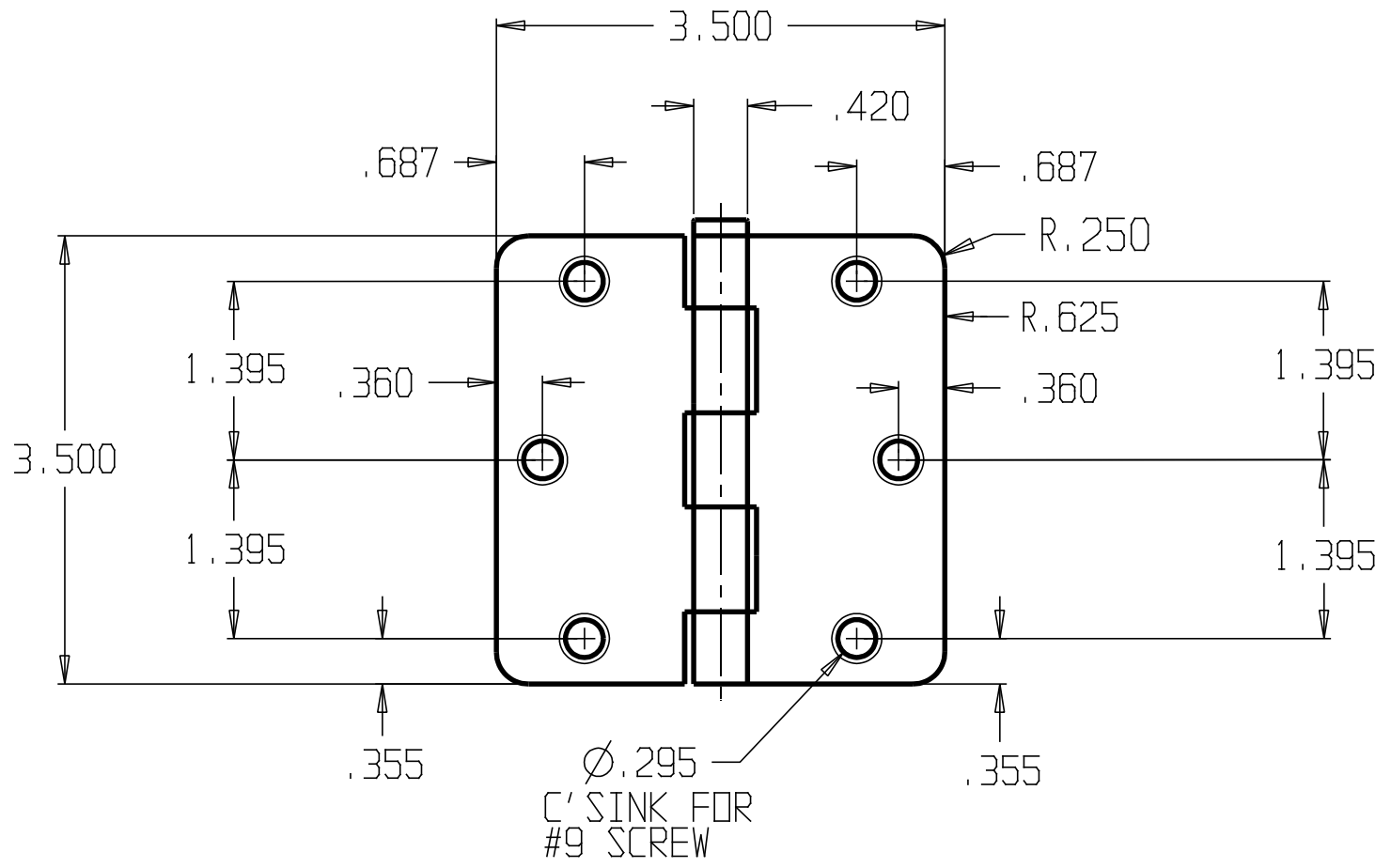

DON-JO MFG. INC.

DESIGNER

APPROVED

| | | | |
|-----------|------------------|-------------------------|-------|
| SIZE A | DATE: 1/13/05 | PART NO. RPB73535-14 | REV |
| SCALE | RELEASE DATE | WEIGHT | SHEET |

| REVISIONS | | FINISHES: | GUAGE: |
|-----------|-----|--------------------|------------|
| ZONE | REV | 632, 633, 640, 652 | 10ga. .135 |

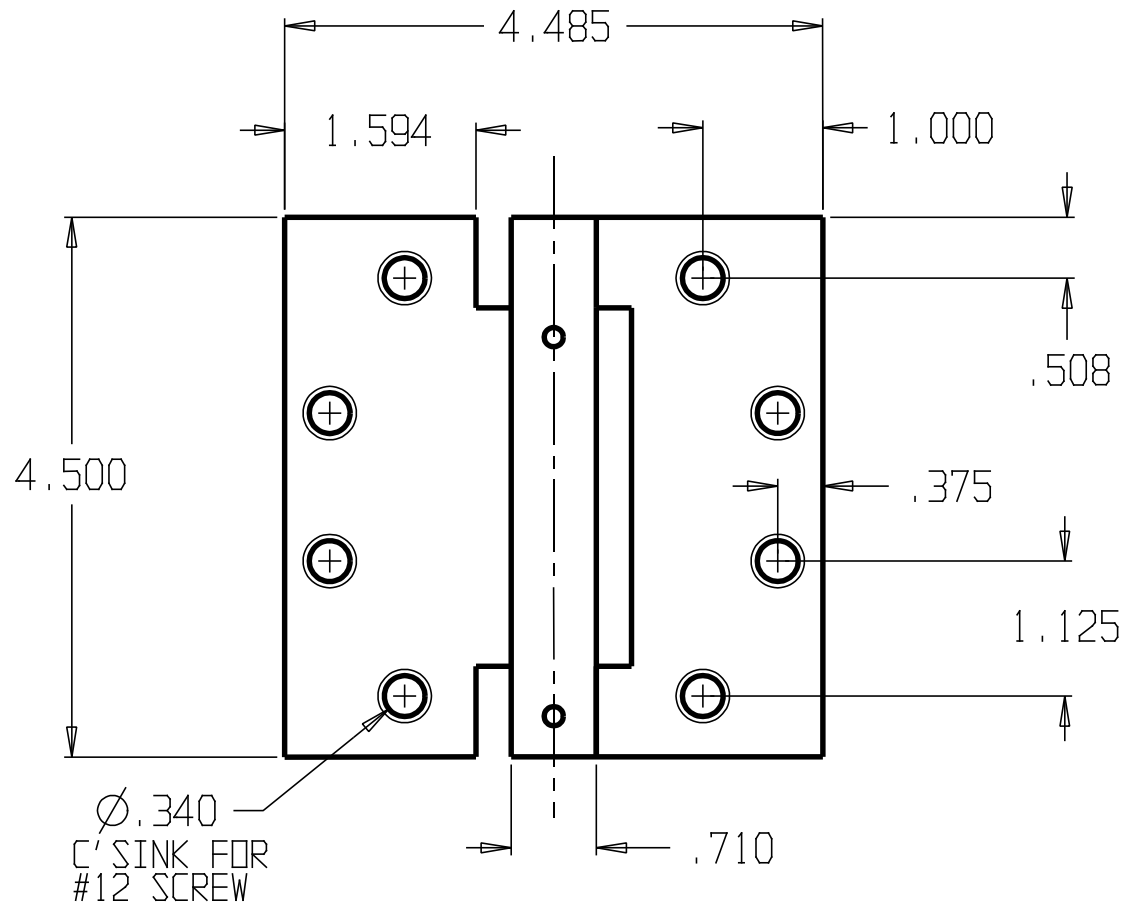

DON-JO MFG. INC.

| | | | | |
|----------|--------|---------------|-------------------|-------|
| DESIGNER | SIZE A | DATE: 1/12/05 | PART NO. SH-74545 | REV |
| APPROVED | SCALE | RELEASE DATE | WEIGHT | SHEET |

| REVISIONS | | | |
|-----------|-----|-----------|------------|
| ZONE | REV | FINISHES: | GAUGE: |
| | | 630 | 10ga. .135 |

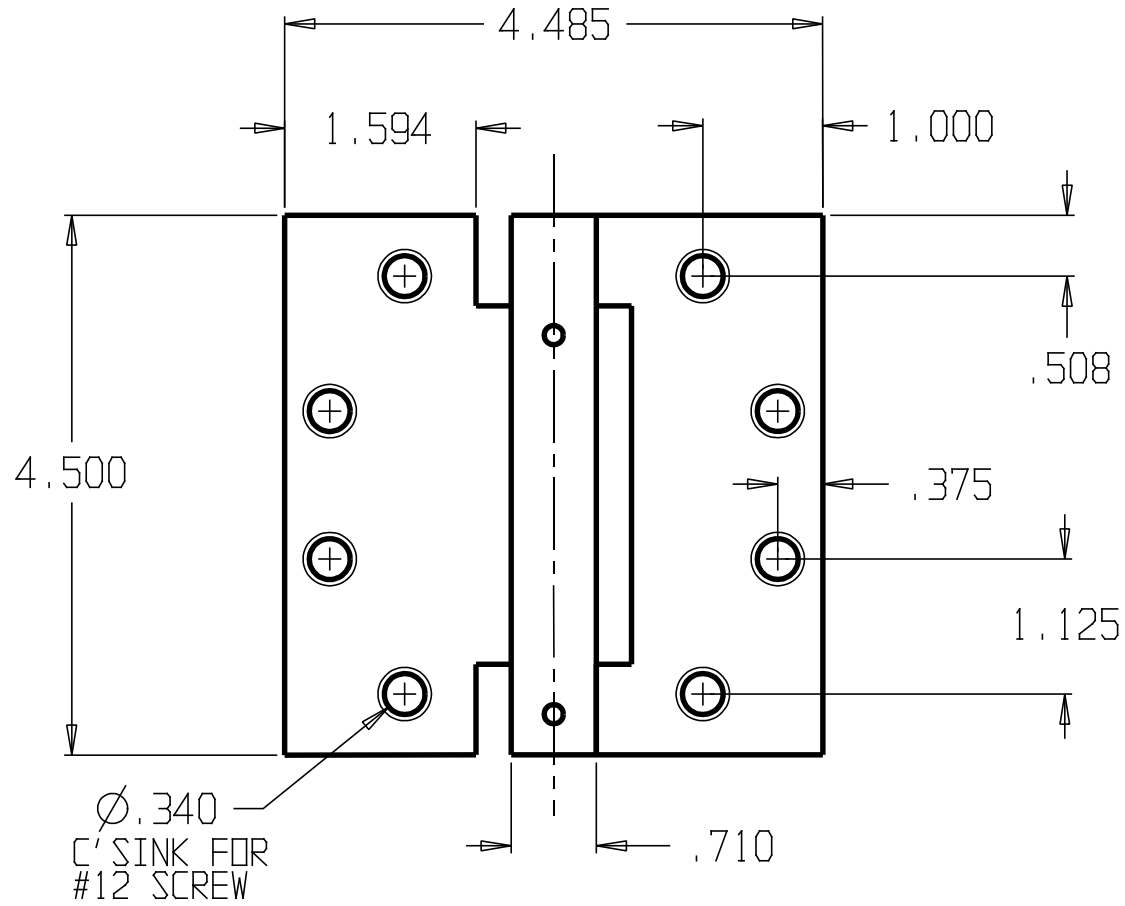

DON-JO MFG. INC.

| | | | | |
|----------|-------|--------------|----------|-------|
| DESIGNER | SIZE | DATE: | PART NO. | REV |
| | A | 1/12/05 | SH-94545 | |
| APPROVED | SCALE | RELEASE DATE | WEIGHT | SHEET |

| REVISIONS | | | |
|-----------|-----|--|----------|
| ZONE | REV | FINISHES : | DATE |
| | | 605, 606, 609, 612, 613, 620, 629, 630 | |
| | | | APPROVED |

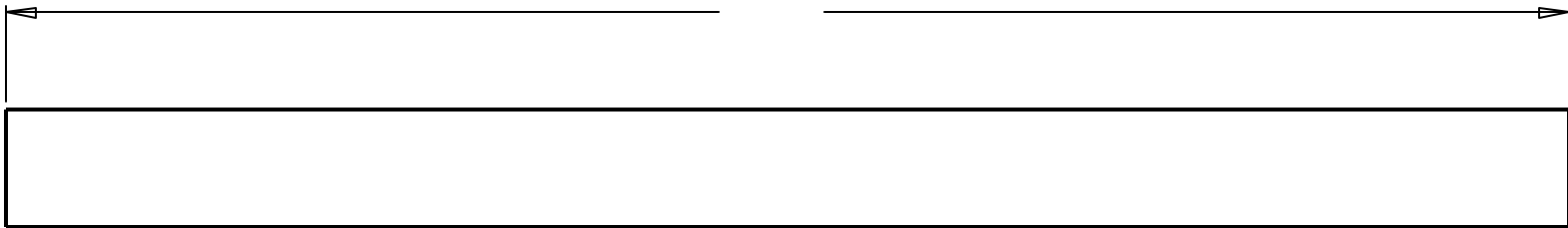
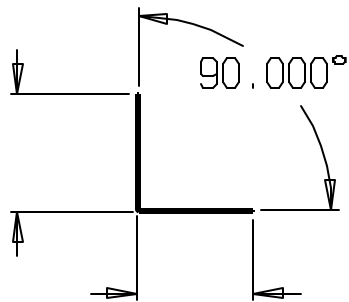

**** Customer To Specify Size and Finish and Fax To Factory For Quote ****

DON-JO MFG. INC.

| | | | | |
|----------|-------|--------------|----------|-------|
| DESIGNER | SIZE | DATE | PART NO. | REV |
| | A | 2/10/04 | #1299 | |
| APPROVED | SCALE | RELEASE DATE | WEIGHT | SHEET |

| REVISIONS | | | |
|-----------|-----|--|----------|
| ZONE | REV | FINISHES: | DATE |
| | | 605, 606, 609, 612, 613, 620, 629, 630 | |
| | | | APPROVED |

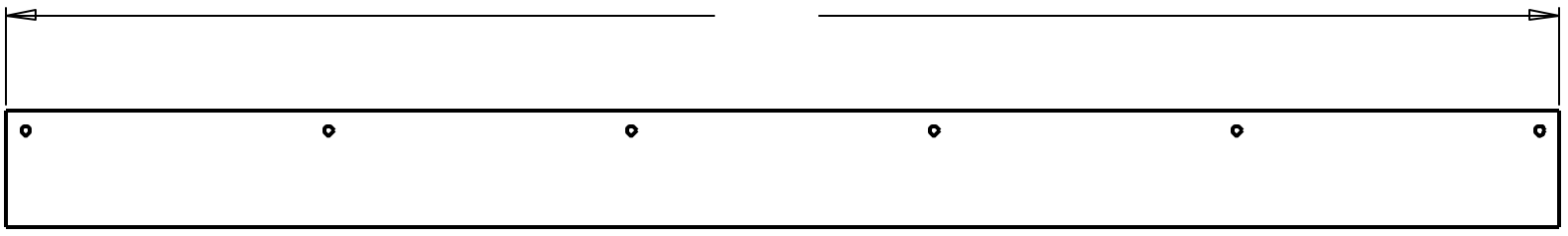
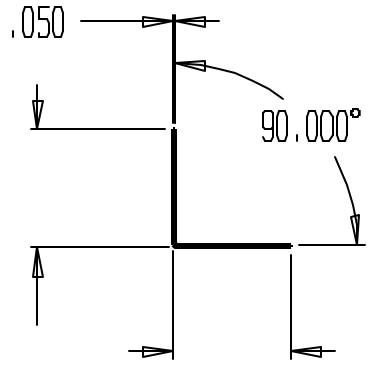

**** Customer To Specify Size and Finish and Fax To Factory For Quote ****

DON-JO MFG. INC.

| | | | | |
|----------|-------|--------------|----------|-------|
| DESIGNER | SIZE | DATE | PART NO. | REV |
| | A | 2/10/04 | #1295 | |
| APPROVED | SCALE | RELEASE DATE | WEIGHT | SHEET |

| REVISIONS | | | |
|-----------|-----|--|----------|
| ZONE | REV | FINISHES : | DATE |
| | | 605, 606, 609, 612, 613, 620, 629, 630 | |
| | | | APPROVED |

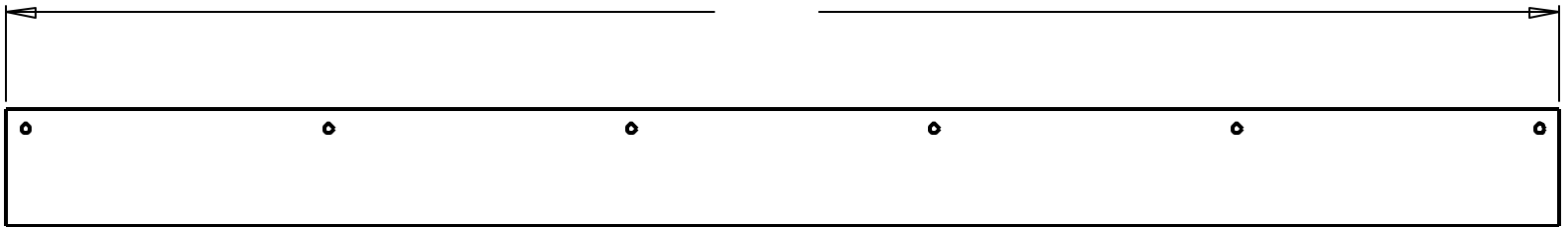
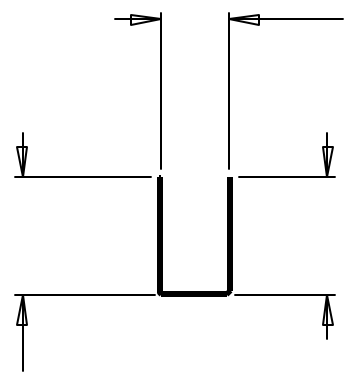

**** Customer To Specify Size and Finish and Fax To Factory For Quote ****
**** Maximum Legs For 1.75" Door Up To 48" Is 3" Over 48" Is 2.5" ****

DON-JO MFG. INC.

| | | | | |
|----------|-----------|-----------------|-------------------|-------|
| DESIGNER | SIZE A | DATE 2/10/04 | PART NO. #1299 | REV |
| APPROVED | SCALE | RELEASE DATE | WEIGHT | SHEET |

| REVISIONS | | |
|-----------|-----|--|
| ZONE | REV | FINISHES: |
| | | Brass, Bronze, Plain Steel, Stainless Steel |
| | | GAUGE: 18ga .050 |

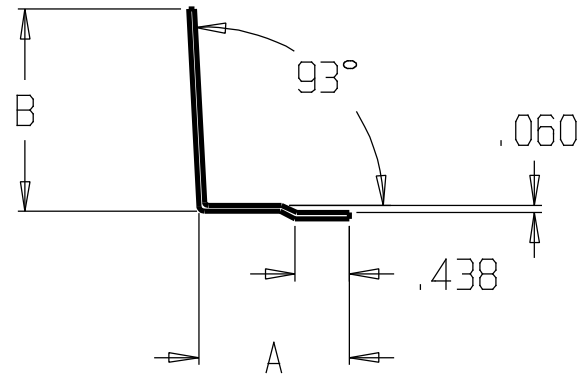

DON-JO MFG. INC.

| | | | | |
|----------|-----------|------------------|-------------------|-------|
| DESIGNER | SIZE A | DATE: 2/22/11 | PART NO. #1313 | REV |
| APPROVED | SCALE | RELEASE DATE | WEIGHT | SHEET |

| REVISIONS | | | | |
|-----------|-----|-----------|------|----------|
| ZONE | REV | FINISHES: | DATE | APPROVED |
| | | 630 | | |

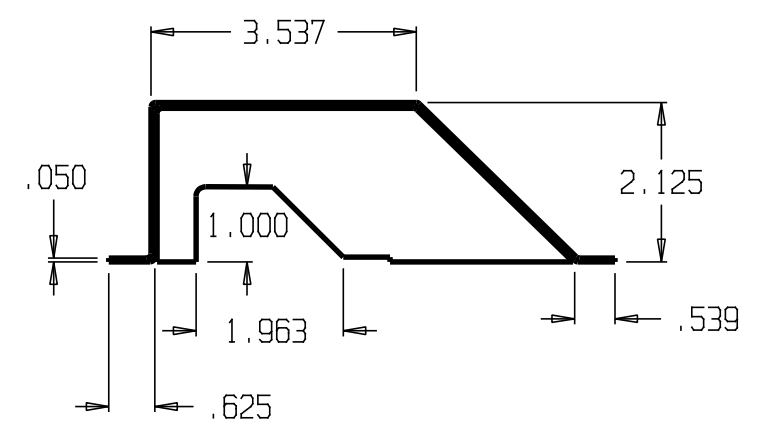
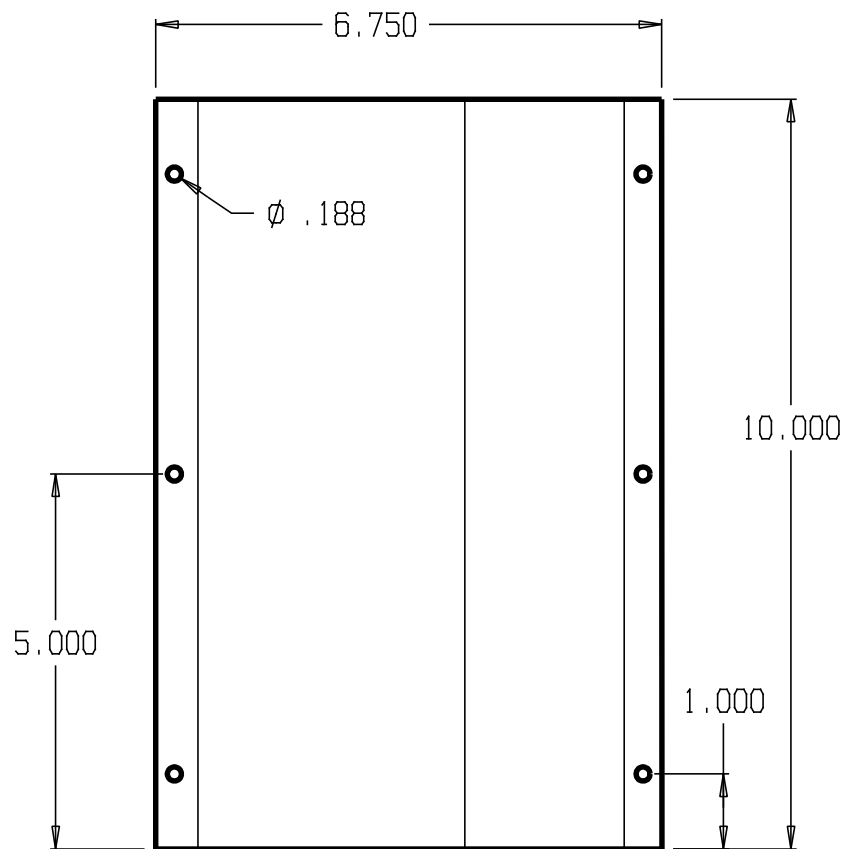

DON-JO MFG. INC.

| | | | | |
|----------|-----------|------------------|-----------------|-------|
| DESIGNER | SIZE A | DATE: 4/29/04 | PART NO. #81 | REV |
| APPROVED | SCALE | RELEASE DATE | WEIGHT | SHEET |

| REVISIONS | | | | |
|-----------|-----|-----------|------|----------|
| ZONE | REV | FINISHES: | DATE | APPROVED |
| | | 630 | | |

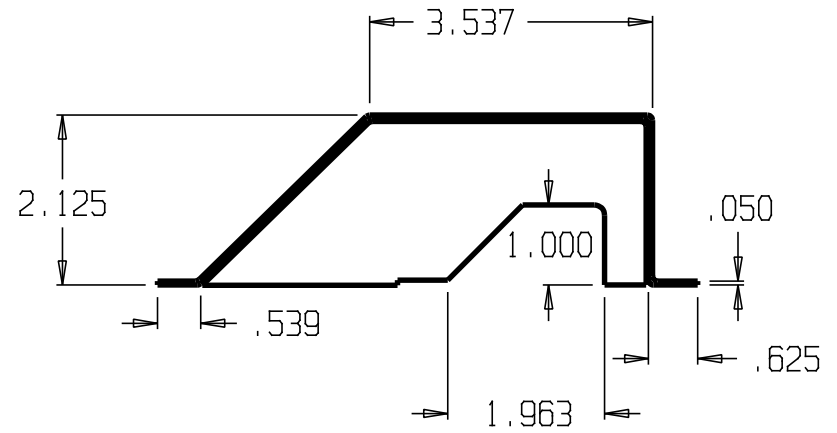
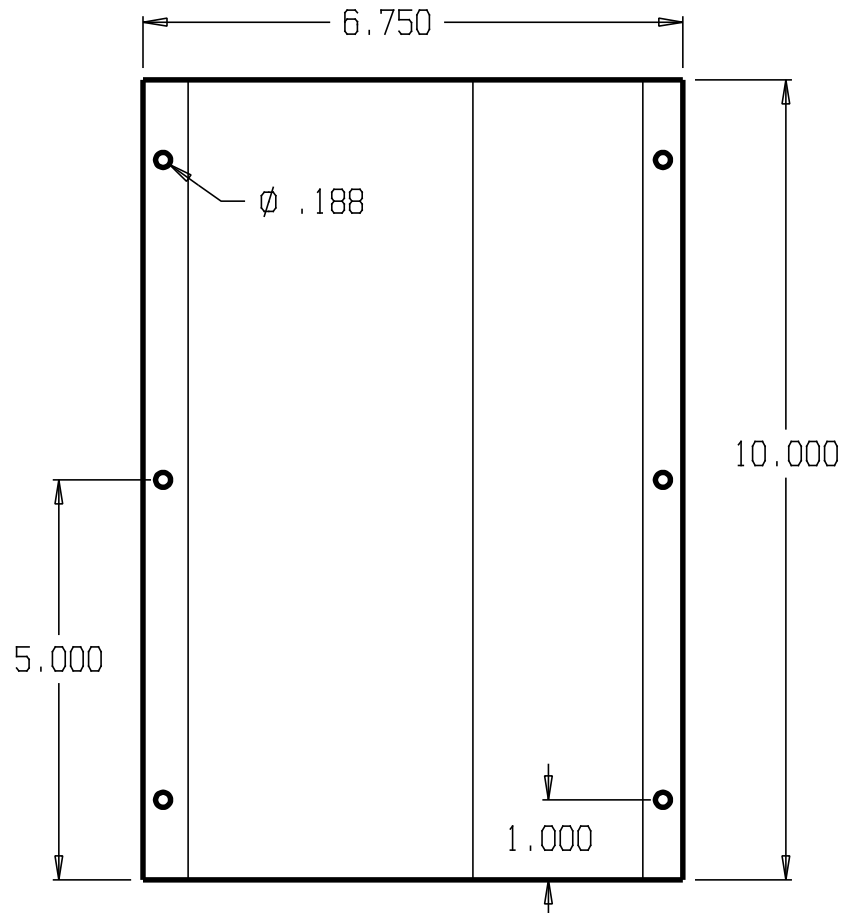

DON-JO MFG. INC.

| | | | | |
|----------|-------|--------------|----------|-------|
| DESIGNER | SIZE | DATE: | PART NO. | REV |
| | A | 4/30/04 | #83 | |
| APPROVED | SCALE | RELEASE DATE | WEIGHT | SHEET |

| REVISIONS | | | | |
|-----------|-----|-----------|------|----------|
| ZONE | REV | FINISHES: | DATE | APPROVED |
| | | 630 | | |

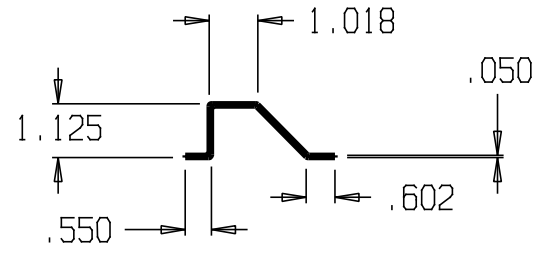
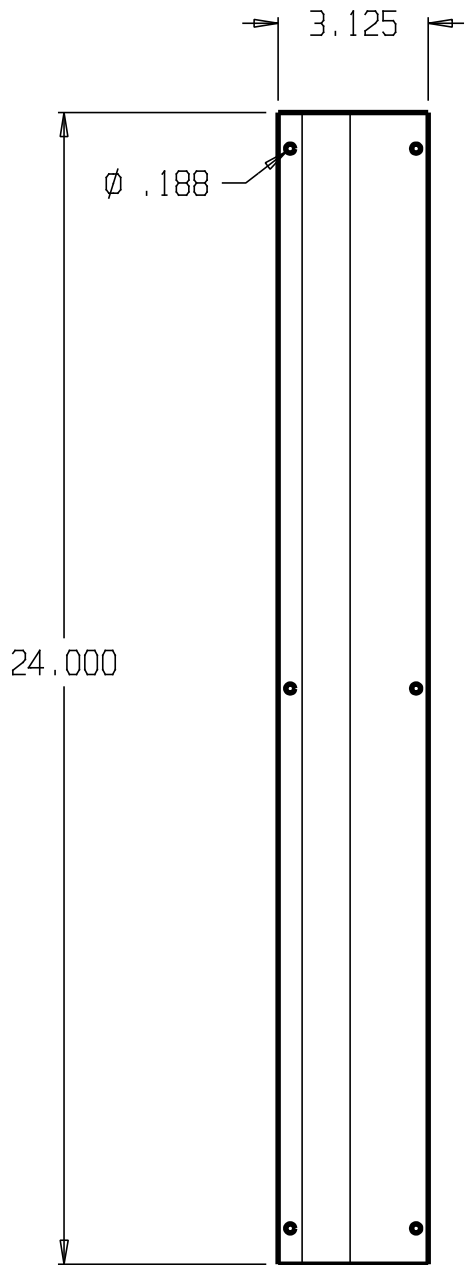

DON-JO MFG. INC.

| | | | | |
|----------|-------|--------------|----------|-------|
| DESIGNER | SIZE | DATE: | PART NO. | REV |
| | A | 4/30/04 | #85 | |
| APPROVED | SCALE | RELEASE DATE | WEIGHT | SHEET |

| | | |
|---------|----|-----|
| DWG NO. | SH | REV |
|---------|----|-----|

| REVISIONS | | |
|-----------|-----|------------|
| ZONE | REV | FINISHES : |
| | | 630 |
| | | GALUGE : |
| | | .188" |

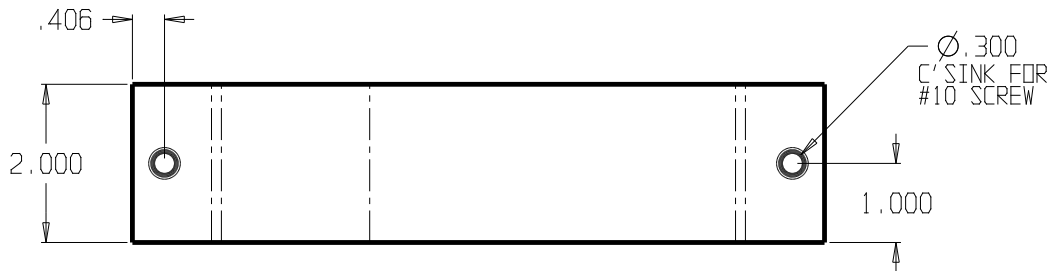
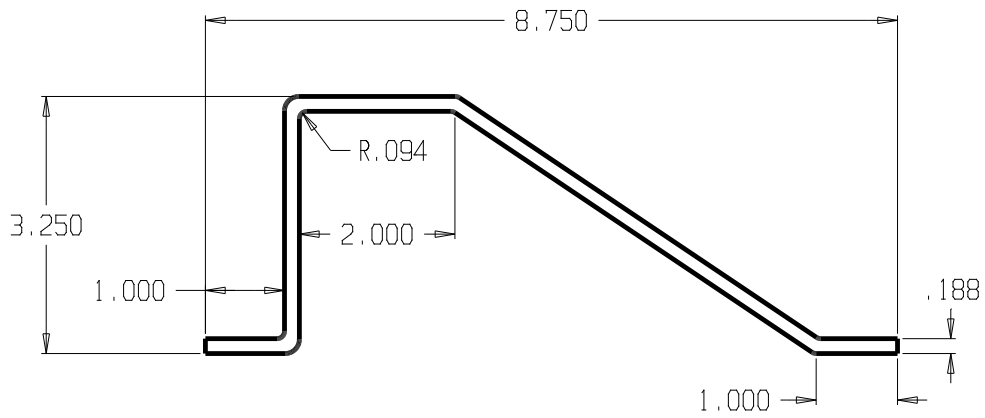

| | |
|------------------|------|
| DON-JO MFG. INC. | |
| DESIGNER | D.R. |

| | | | |
|-------|--------------|----------|-------|
| SIZE | DATE: | PART NO. | REV |
| A | 4/8/10 | #87 | |
| SCALE | RELEASE DATE | WEIGHT | SHEET |

REVISIONS

| ZONE | REV | FINISHES : | Gauge : | APPROVED |
|------|-----|--|---------|----------|
| | | 605, 606, 609, 612, 613, 619, 626, 628, 629, 630, BT, DB, ENDURANCE, PLASTIC | | |

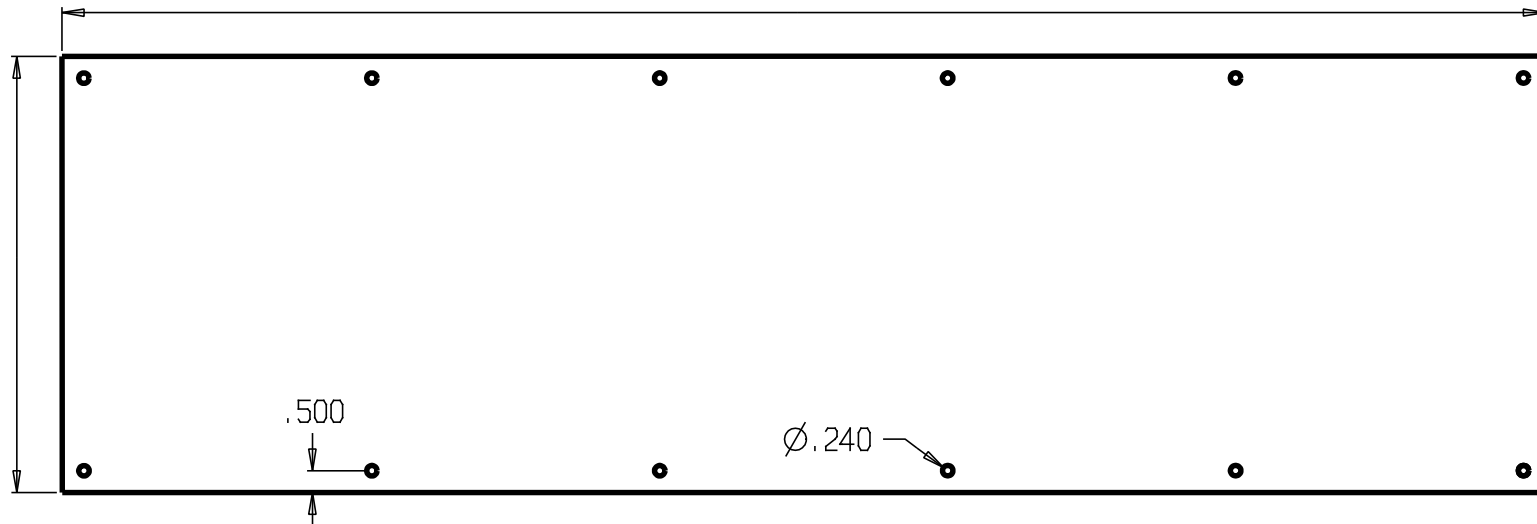

.050 / FILL IN DIMENSIONS

DON-JO MFG. INC.

| | | | | |
|----------|-------|--------------|----------|-------|
| DESIGNER | SIZE | DATE: | PART NO. | REV |
| | A | 2/10/04 | #90 | |
| APPROVED | SCALE | RELEASE DATE | WEIGHT | SHEET |

REVISIONS

| ZONE | REV | FINISHES : | Gauge : | APPROVED |
|------|-----|--|---------|----------|
| | | 605, 606, 609, 612, 613, 619, 626, 628, 629, 630, BT, DB, ENDURANCE, PLASTIC | | |

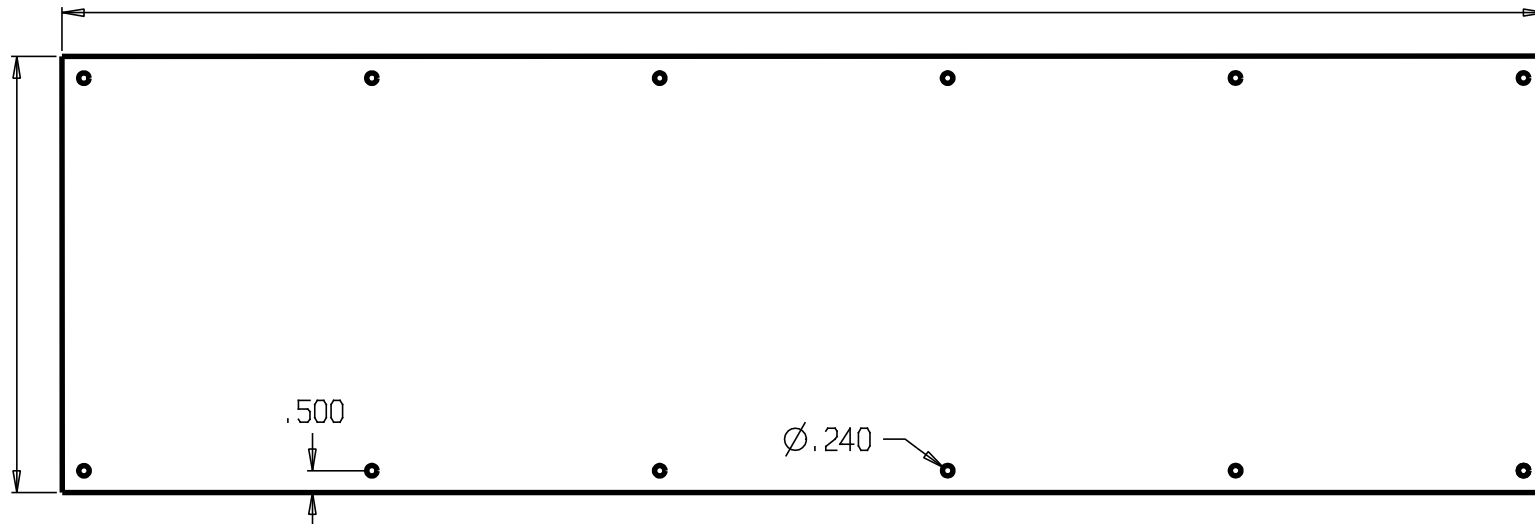

.038 / FILL IN DIMENSIONS

DON-JO MFG. INC.

| | | | | |
|----------|-----------|------------------|-----------------|-------|
| DESIGNER | SIZE A | DATE: 2/10/04 | PART NO. #91 | REV |
| APPROVED | SCALE | RELEASE DATE | WEIGHT | SHEET |

REVISIONS

| ZONE | REV | FINISHES : | Gauge : | APPROVED |
|------|-----|--|---------|----------|
| | | 605, 606, 609, 612, 613, 619, 626, 628, 629, 630, BT, DB, ENDURANCE, PLASTIC | | |

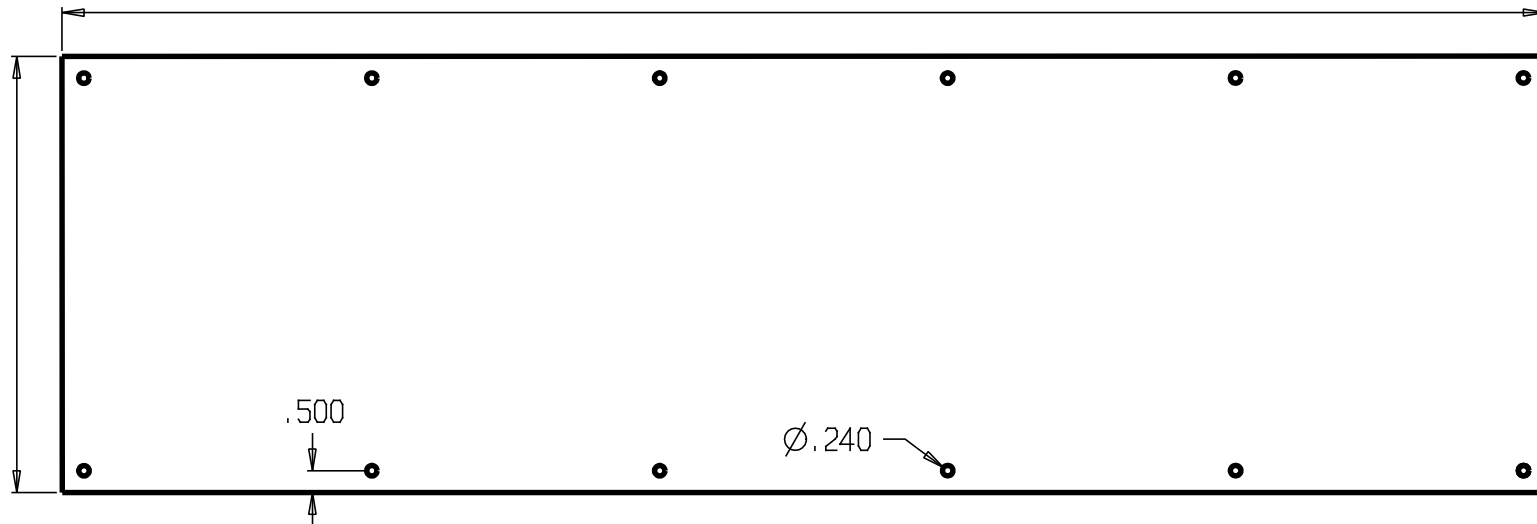

.125" PLASTIC / FILL IN DIMENSIONS

DON-JO MFG. INC.

| | | | | |
|----------|-------|--------------|----------|-------|
| DESIGNER | SIZE | DATE: | PART NO. | REV |
| | A | 2/10/04 | #92 | |
| APPROVED | SCALE | RELEASE DATE | WEIGHT | SHEET |
| | | | | |

REVISIONS

| ZONE | REV | FINISHES : | Gauge : | APPROVED |
|------|-----|--|---------|----------|
| | | 605, 606, 609, 612, 613, 619, 626, 628, 629, 630, BT, DB, ENDURANCE, PLASTIC | | |

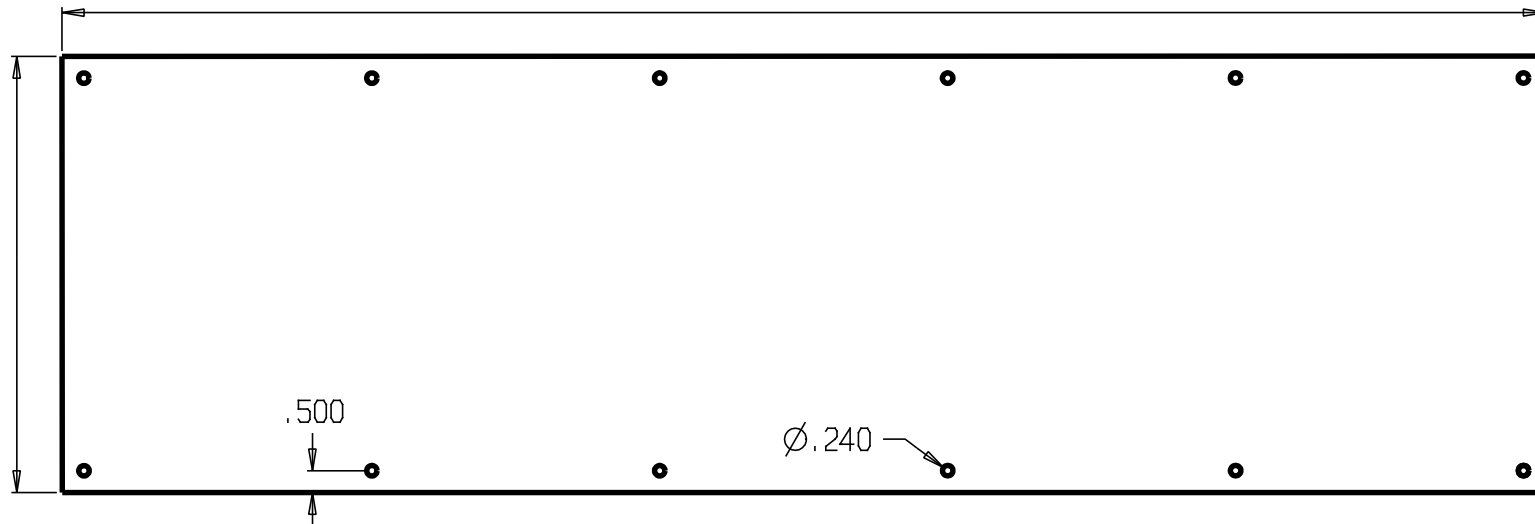

.125" CLEAR PLASTIC / FILL IN DIMENSIONS

DON-JO MFG. INC.

| | | | | |
|----------|-----------|------------------|-----------------|-------|
| DESIGNER | SIZE A | DATE: 2/10/04 | PART NO. #93 | REV |
| APPROVED | SCALE | RELEASE DATE | WEIGHT | SHEET |

| REVISIONS | | |
|-----------|-----|------------------|
| ZONE | REV | FINISHES: |
| | | 626, BP, DU & SL |
| | | GAUGE: |
| | | 12ga. .104 |

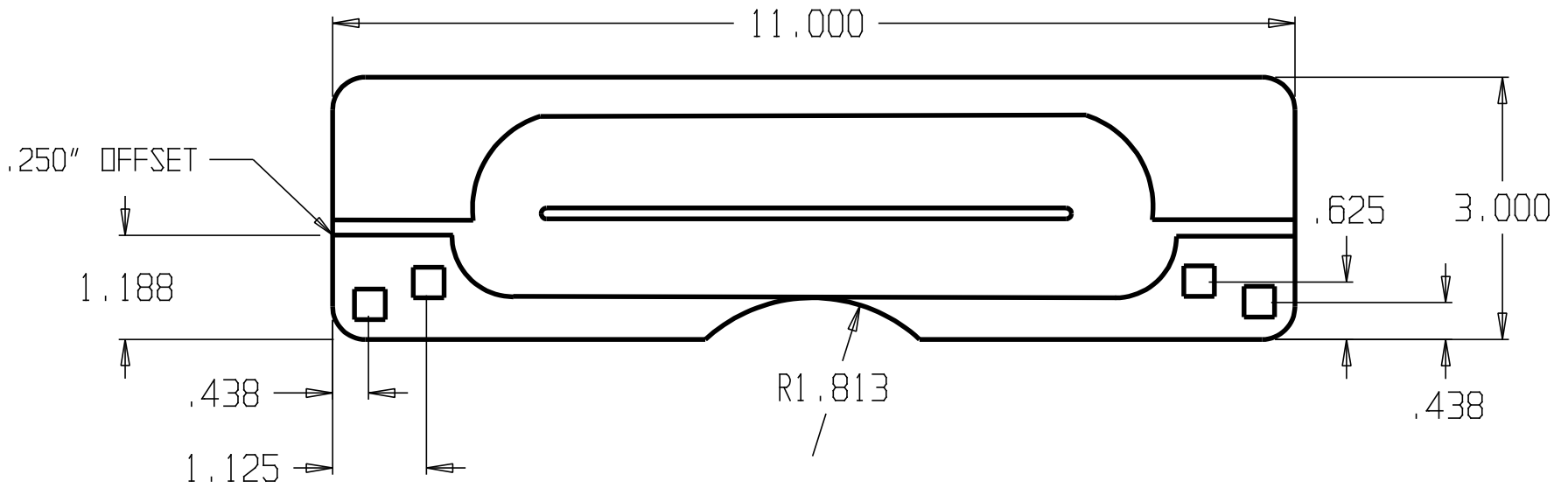

| | | | | | | | |
|------------------|--|-------|--------------|--------|-------|----------|-----|
| DON-JO MFG. INC. | | | | SIZE | DATE: | PART NO. | REV |
| DESIGNER | | A | 5/28/04 | LP-211 | | | |
| APPROVED | | SCALE | RELEASE DATE | WEIGHT | SHEET | | |

| REVISIONS | | |
|-----------|-----|------------------|
| ZONE | REV | FINISHES: |
| | | 626, BP, DU & SL |
| | | GAUGE: |
| | | 12ga. .104 |

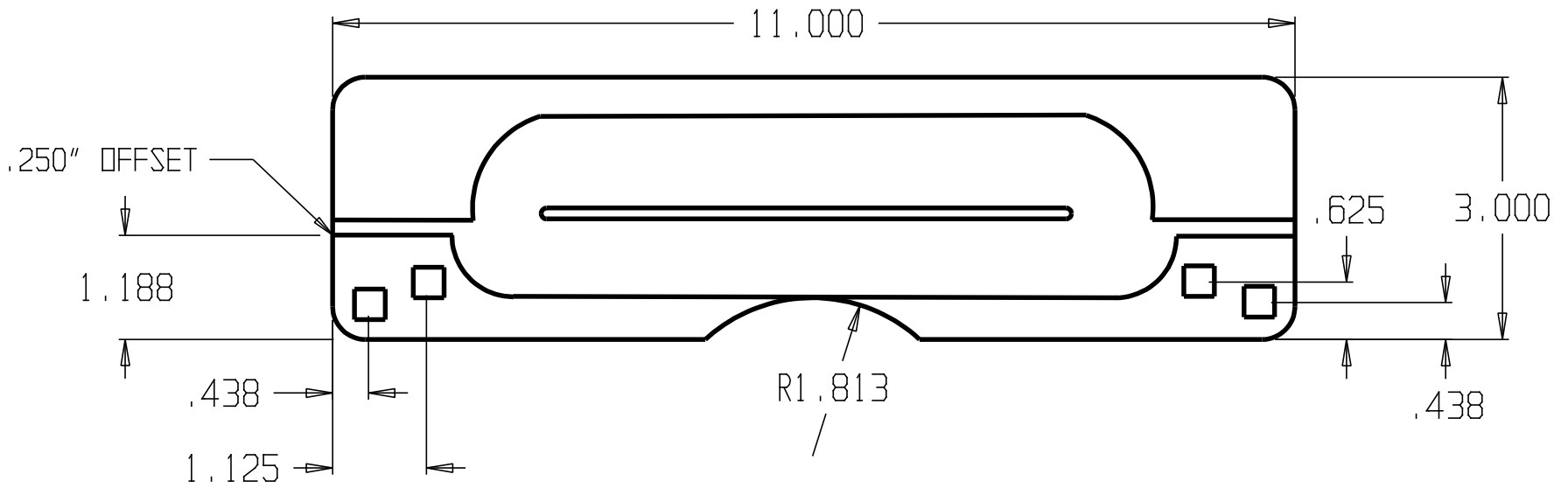

| | | | | | | | |
|------------------|--|-------|--------------|--------|-------|----------|-----|
| DON-JO MFG. INC. | | | | SIZE | DATE: | PART NO. | REV |
| DESIGNER | | A | 5/28/04 | LP-211 | | | |
| APPROVED | | SCALE | RELEASE DATE | WEIGHT | SHEET | | |

| REVISIONS | | |
|-----------|-----|------------|
| ZONE | REV | FINISHES: |
| | | DU & SL |
| | | GAUGE: |
| | | 13ga. .095 |

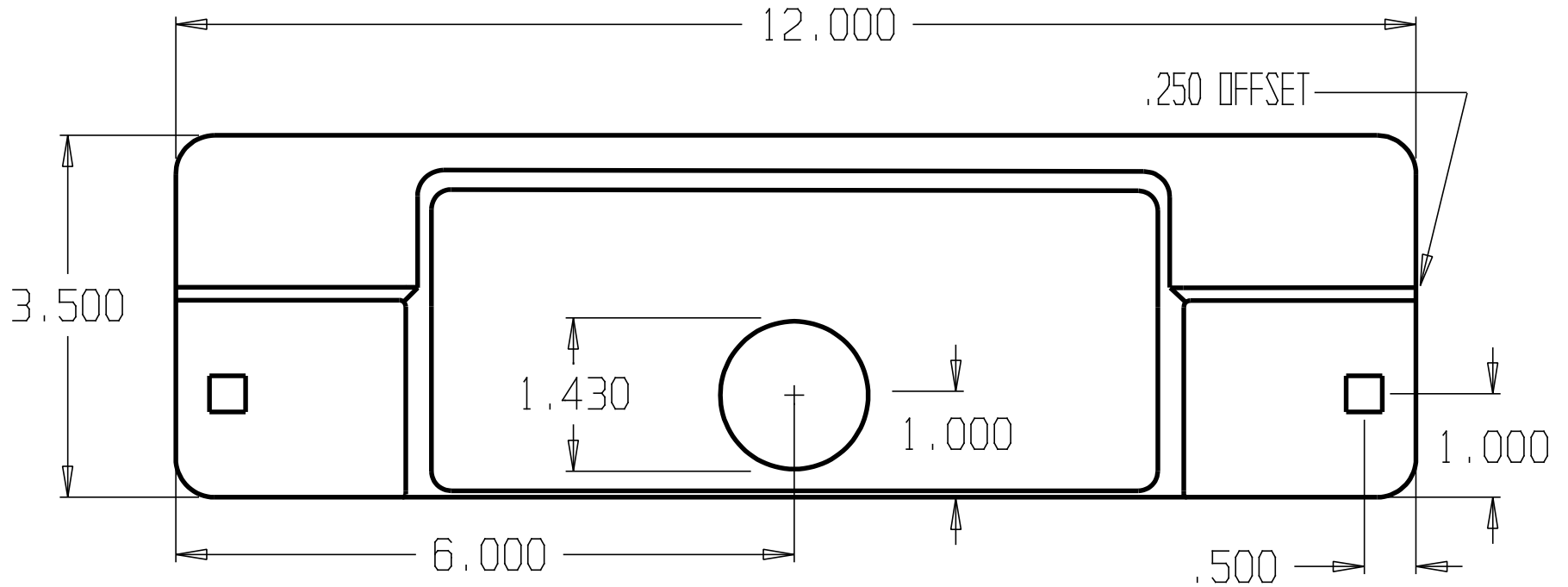

| | | | | | |
|------------------|--|-------|--------------|----------|-------|
| DON-JO MFG. INC. | | SIZE | DATE: | PART NO. | REV |
| DESIGNER | | A | 5/3/04 | AL-211 | |
| APPROVED | | SCALE | RELEASE DATE | WEIGHT | SHEET |

| REVISIONS | | | |
|-----------|-----|-------------|------------|
| ZONE | REV | FINISHES: | GALUGE: |
| | | BC, DU & SL | 10ga. .134 |

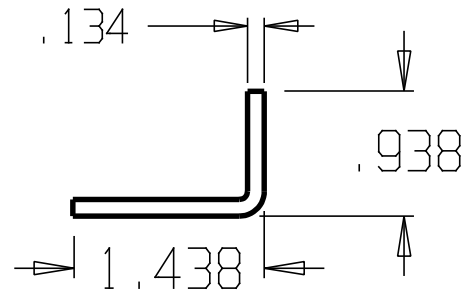
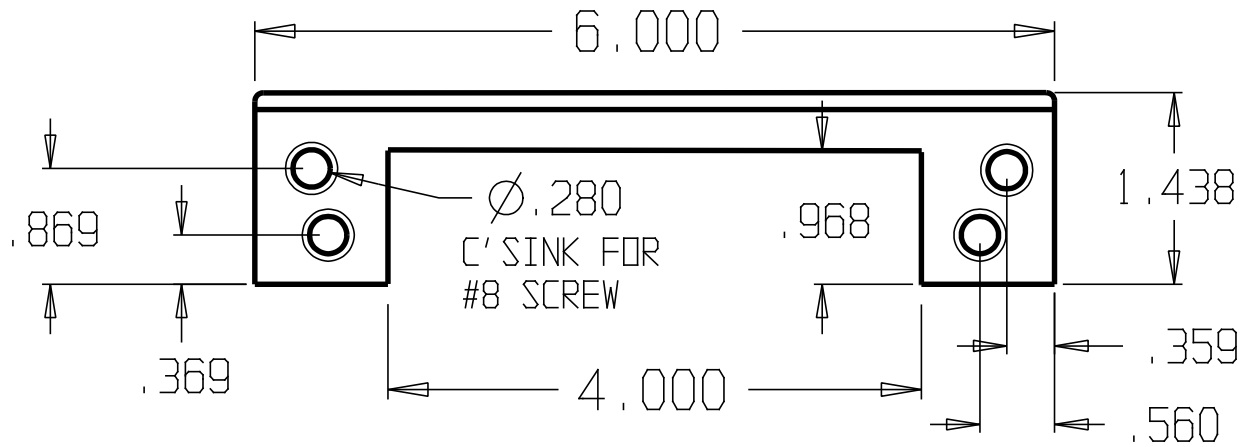

DON-JO MFG. INC.

| | | | | |
|----------|-------|--------------|----------|-------|
| DESIGNER | SIZE | DATE: | PART NO. | REV |
| | A | 5/3/04 | ALP-206 | |
| APPROVED | SCALE | RELEASE DATE | WEIGHT | SHEET |
| | | | | |

| REVISIONS | | | |
|-----------|-----|-------------|------------|
| ZONE | REV | FINISHES: | GUAGE: |
| | | BC, DU & SL | 10ga. .134 |

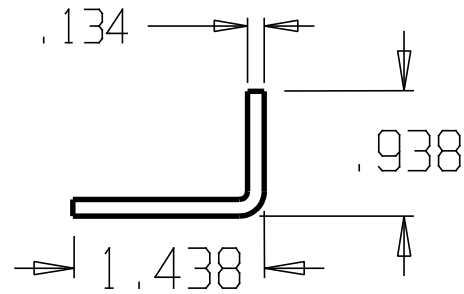
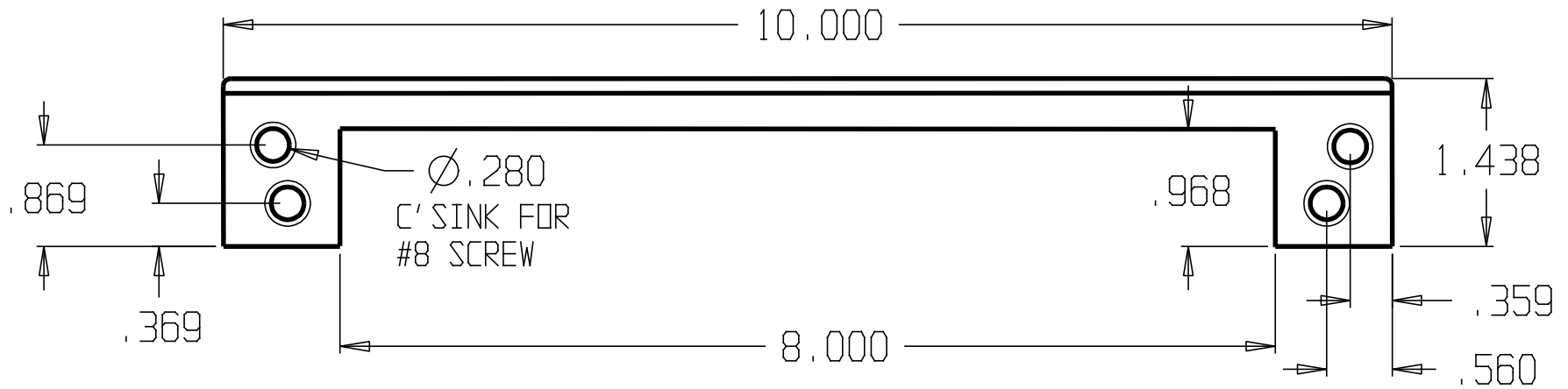

DON-JO MFG. INC.

| | | | | |
|----------|-------|--------------|----------|-------|
| DESIGNER | SIZE | DATE: | PART NO. | REV |
| | A | 5/3/04 | ALP-210 | |
| APPROVED | SCALE | RELEASE DATE | WEIGHT | SHEET |

| REVISIONS | | | |
|-----------|-----|-----------|------------|
| ZONE | REV | FINISHES: | GALUGE: |
| | | 630 | 12ga. .104 |

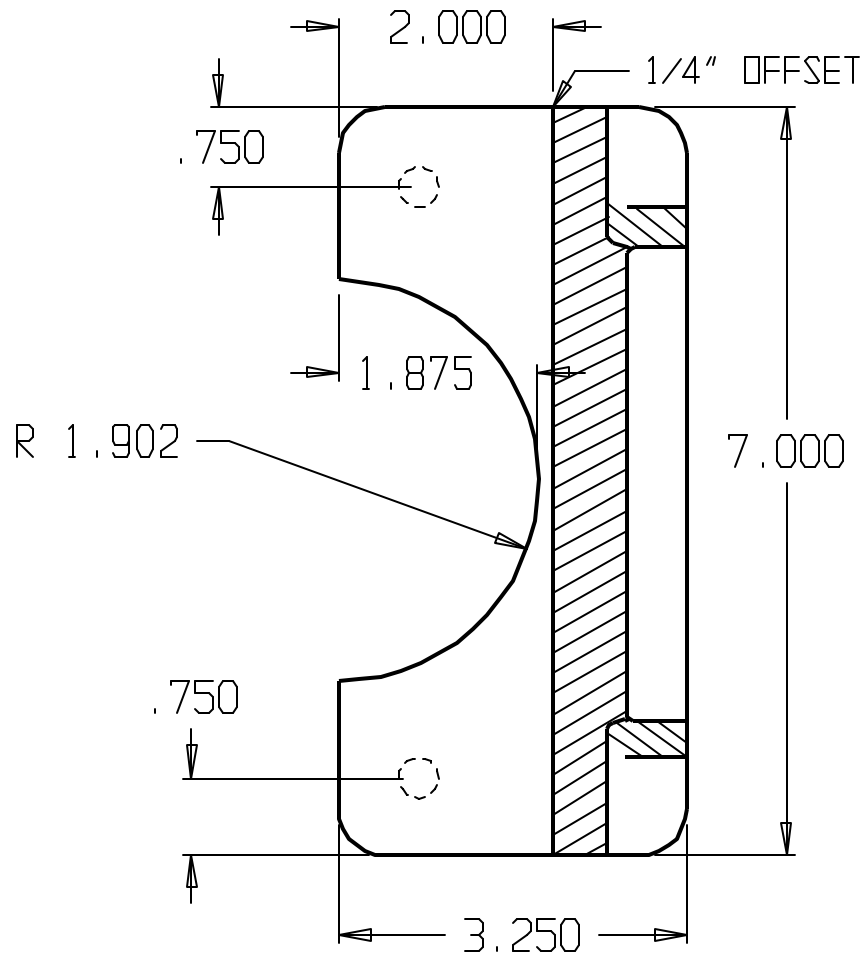

DON-JO MFG. INC.

| | | | | |
|----------|-------|--------------|----------|-------|
| DESIGNER | SIZE | DATE: | PART NO. | REV |
| | A | 5/4/04 | BLP-107 | |
| APPROVED | SCALE | RELEASE DATE | WEIGHT | SHEET |
| | | | | |

| REVISIONS | | | |
|-----------|-----|-----------|------------|
| ZONE | REV | FINISHES: | GALUGE: |
| | | 630 | 12ga. .104 |

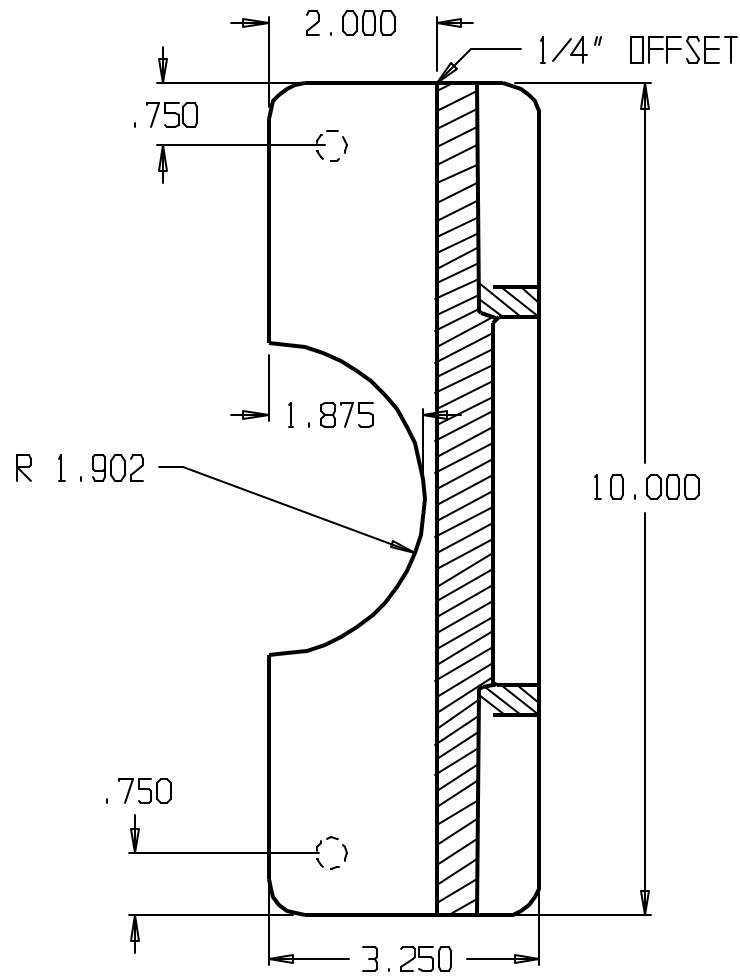

DON-JO MFG. INC.

| | | | | |
|----------|-------|--------------|----------|-------|
| DESIGNER | SIZE | DATE | PART NO. | REV |
| | A | 5/4/04 | BLP-110 | |
| APPROVED | SCALE | RELEASE DATE | WEIGHT | SHEET |

| REVISIONS | | | |
|-----------|-----|-------------|------------|
| ZONE | REV | FINISHES: | GALUGE: |
| | | BP, DU & SL | 12ga. .104 |

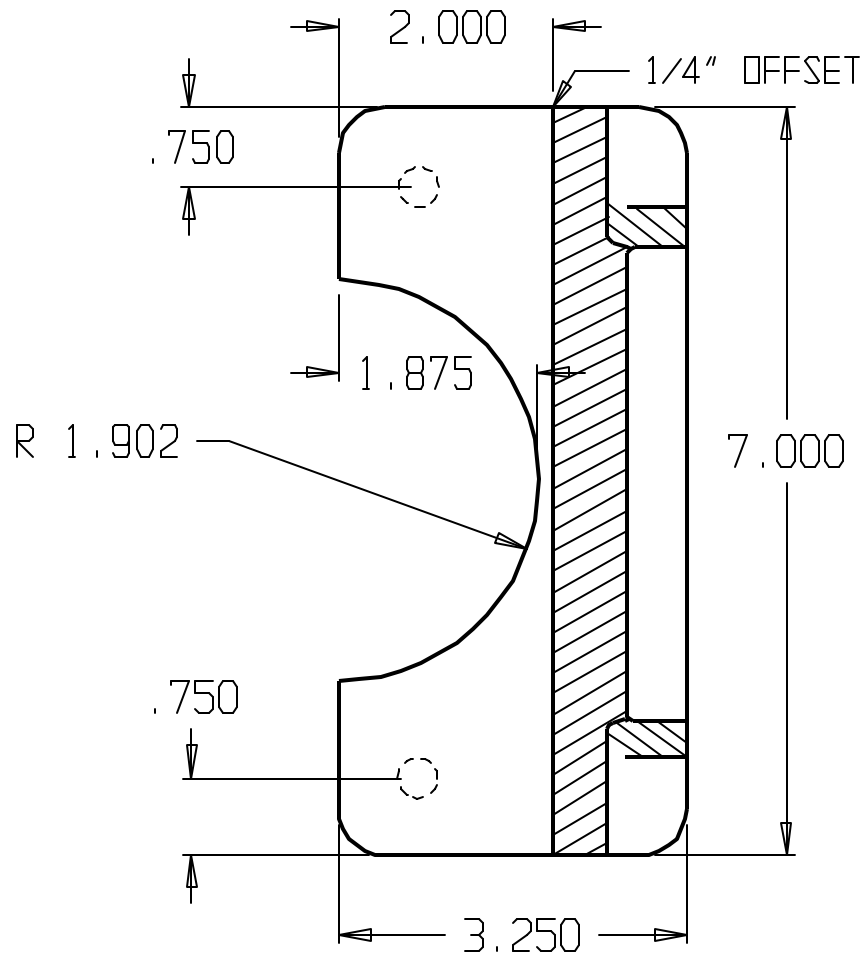

DON-JO MFG. INC.

| | | | | |
|----------|-------|--------------|----------|-------|
| DESIGNER | SIZE | DATE: | PART NO. | REV |
| | A | 5/4/04 | BLP-207 | |
| APPROVED | SCALE | RELEASE DATE | WEIGHT | SHEET |

| REVISIONS | | | |
|-----------|-----|-------------|------------|
| ZONE | REV | FINISHES: | GUAGE: |
| | | BP, DU & SL | 12ga. .104 |

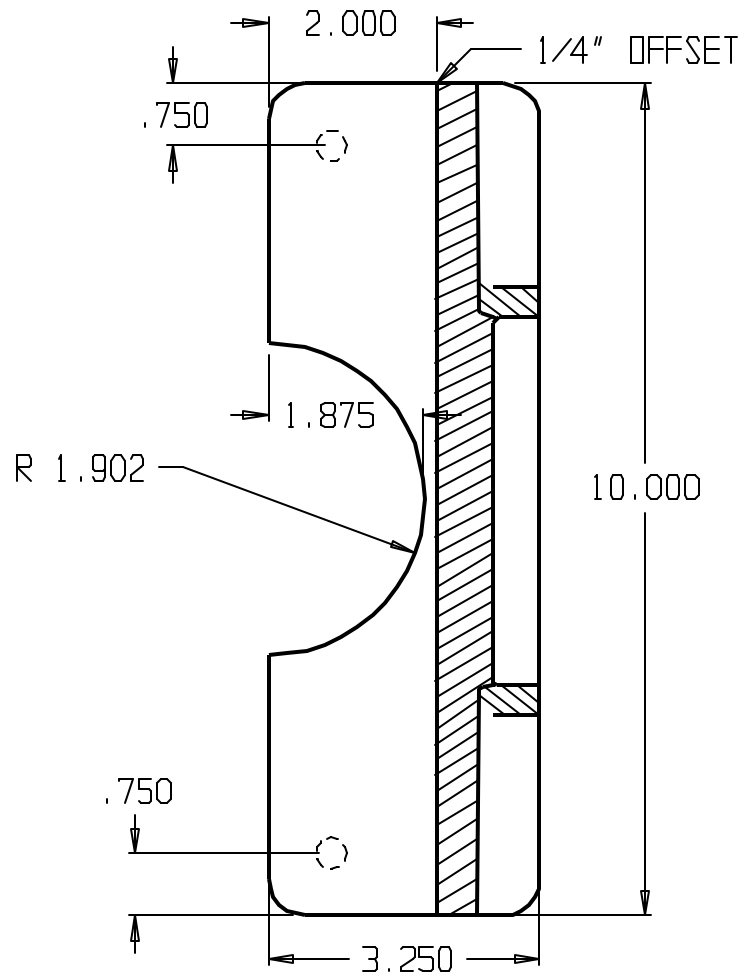

DON-JO MFG. INC.

| | | | | |
|----------|-----------|----------------|---------------------|-------|
| DESIGNER | SIZE A | DATE 5/4/04 | PART NO. BLP-210 | REV |
| APPROVED | SCALE | RELEASE DATE | WEIGHT | SHEET |

| REVISIONS | | | |
|-----------|-----|-----------|------------|
| ZONE | REV | FINISHES: | GAUGE: |
| | | 630 | 12ga. .104 |

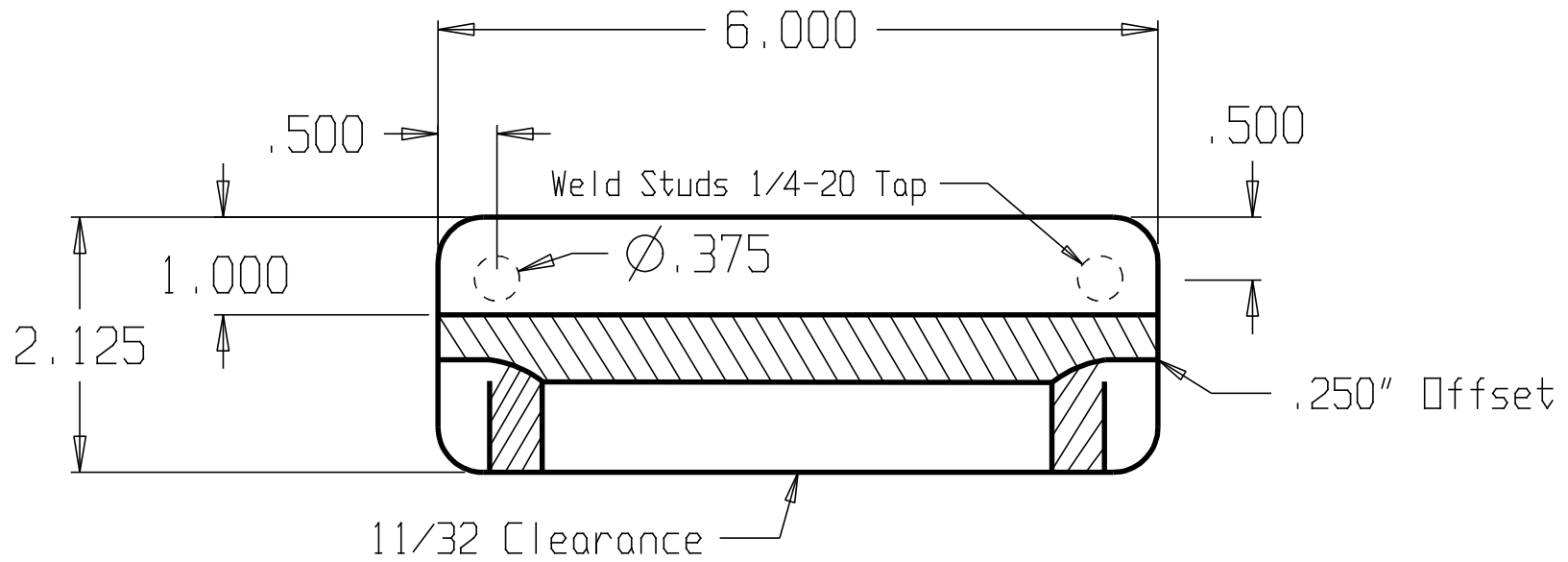

DON-JO MFG. INC.

| | | | | |
|----------|-------|--------------|----------|-------|
| DESIGNER | SIZE | DATE: | PART NO. | REV |
| | A | 6/3/04 | CLP-106 | |
| APPROVED | SCALE | RELEASE DATE | WEIGHT | SHEET |
| | | | | |

| REVISIONS | | | |
|-----------|-----|-----------|------------|
| ZONE | REV | FINISHES: | GAUGE: |
| | | 630 | 12ga. .104 |

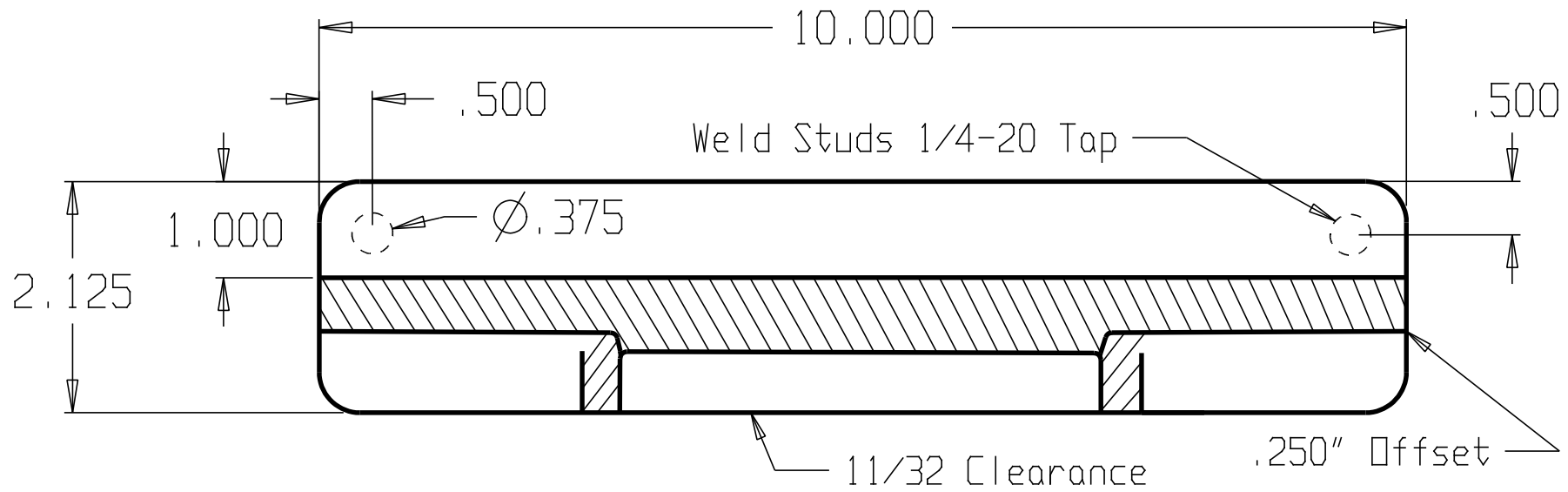

DON-JO MFG. INC.

| | |
|----------|--|
| DESIGNER | |
| APPROVED | |

| | | | |
|-----------|-----------------|---------------------|-------|
| SIZE A | DATE: 5/6/04 | PART NO. CLP-110 | REV |
| SCALE | RELEASE DATE | WEIGHT | SHEET |

| REVISIONS | | |
|-----------|-----|------------|
| ZONE | REV | FINISHES: |
| | | DU & SL |
| | | GUAGE: |
| | | 12ga. .104 |

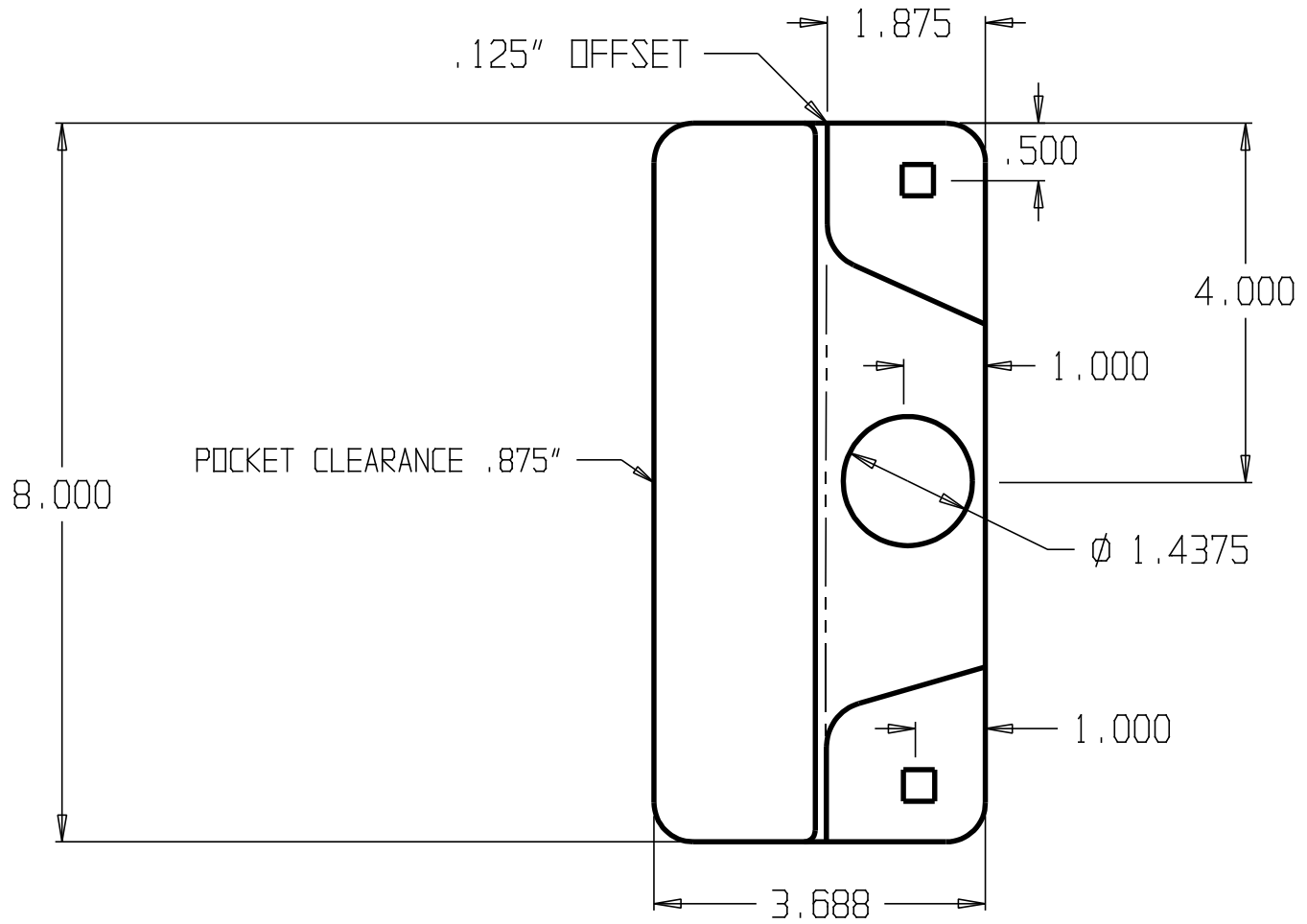

DON-JO MFG. INC.

| | | | | | | | | | |
|----------|--|-------|---|--------------|---------|----------|---------|-------|--|
| DESIGNER | | SIZE | A | DATE: | 5/17/04 | PART NO. | ELP-208 | REV | |
| APPROVED | | SCALE | | RELEASE DATE | | WEIGHT | | SHEET | |

| | | | | | | | | | |
|----------|--|-------|---|--------------|---------|----------|---------|-------|--|
| DESIGNER | | SIZE | A | DATE: | 5/17/04 | PART NO. | ELP-208 | REV | |
| APPROVED | | SCALE | | RELEASE DATE | | WEIGHT | | SHEET | |

| REVISIONS | | |
|-----------|-----|------------|
| ZONE | REV | FINISHES: |
| | | DU & SL |
| | | GAUGE: |
| | | 12ga. .104 |

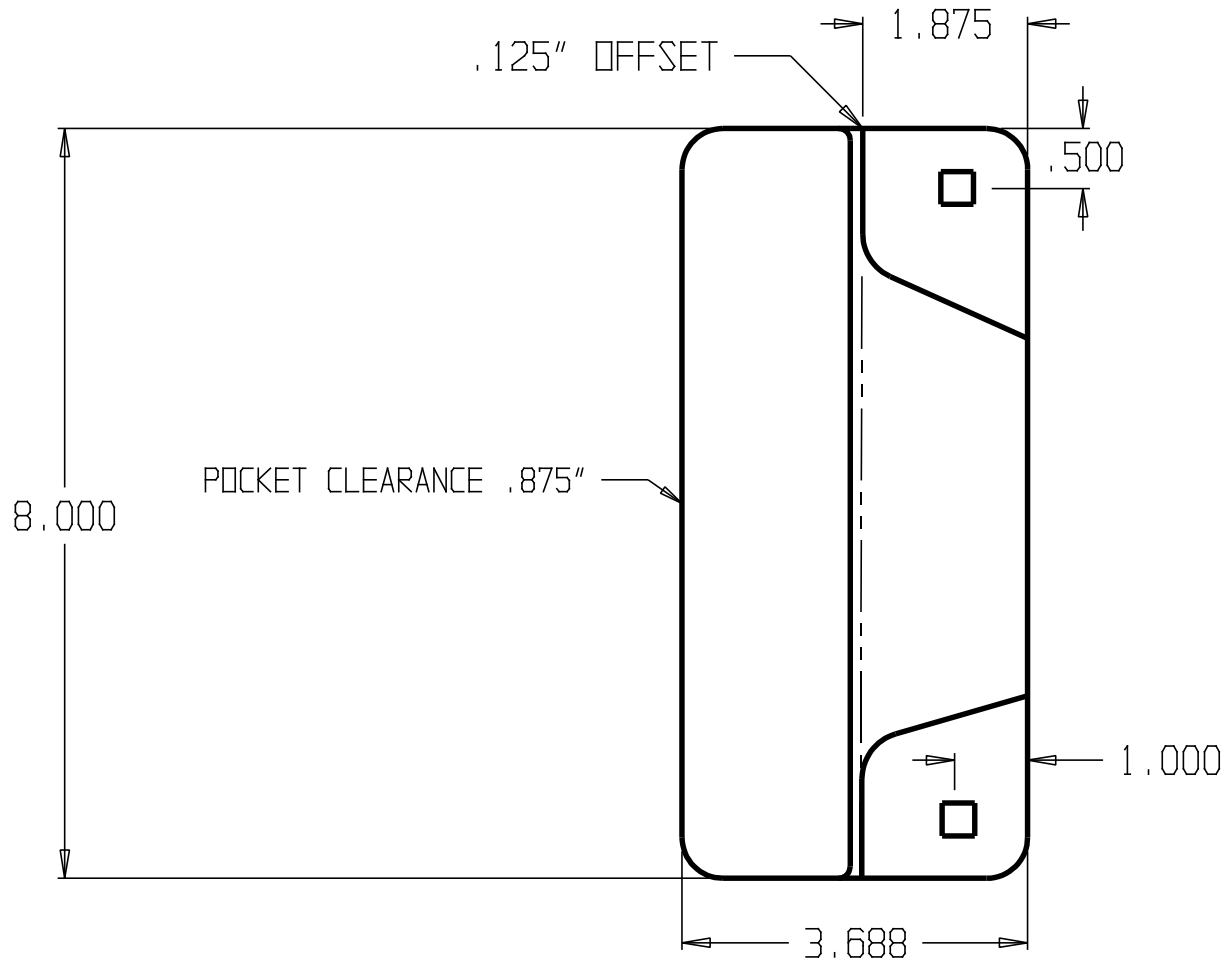

DON-JO MFG. INC.

| | | | | |
|----------|-------|--------------|----------|-------|
| DESIGNER | SIZE | DATE: | PART NO. | REV |
| | A | 5/17/04 | ELP-208P | |
| APPROVED | SCALE | RELEASE DATE | WEIGHT | SHEET |
| | | | | |

| REVISIONS | | |
|-----------|-----|------------|
| ZONE | REV | FINISHES: |
| | | DU & SL |
| | | GAUGE: |
| | | 12ga. .104 |

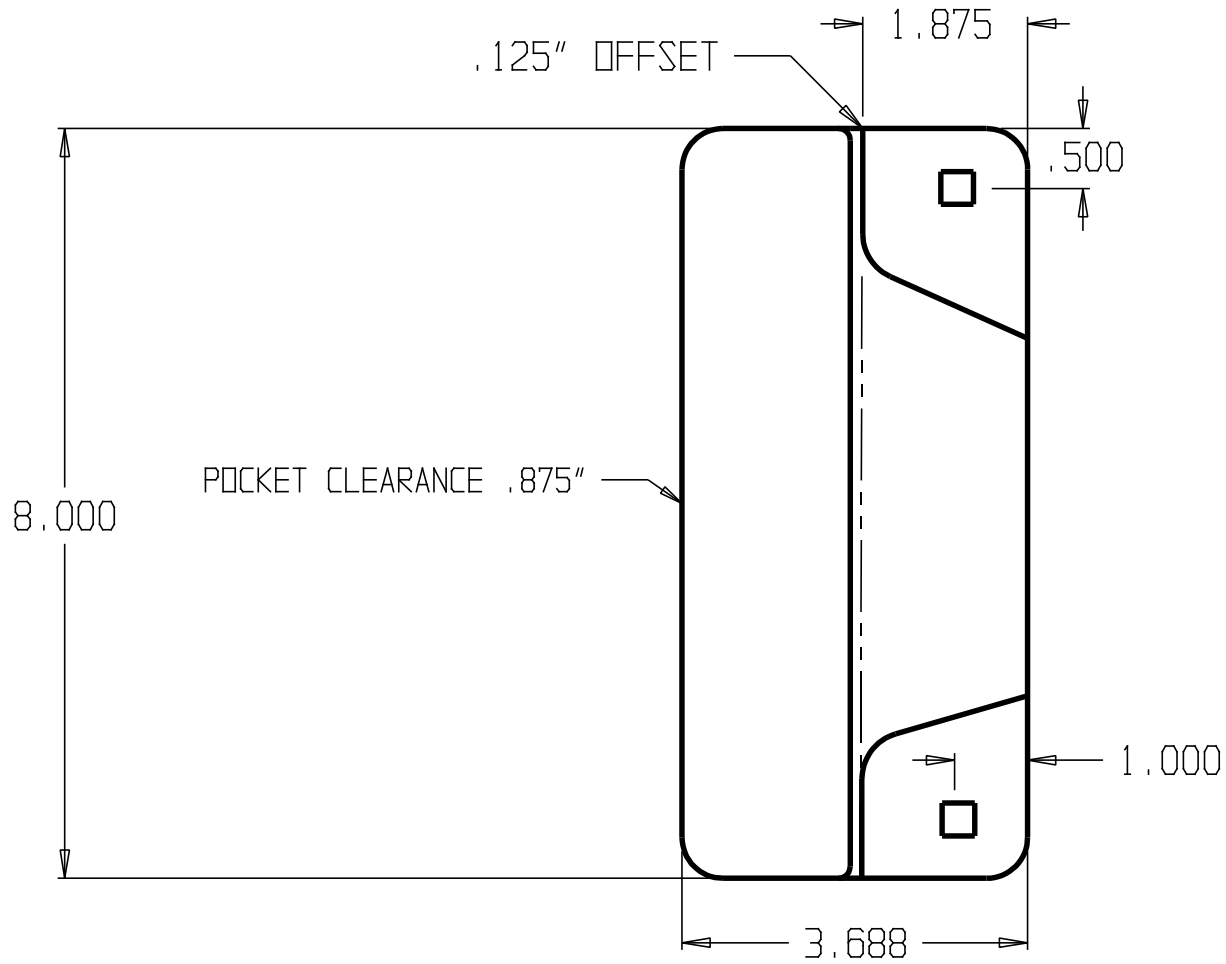

DON-JO MFG. INC.

| | | | | |
|----------|-------|--------------|----------|-------|
| DESIGNER | SIZE | DATE: | PART NO. | REV |
| | A | 5/17/04 | ELP-208P | |
| APPROVED | SCALE | RELEASE DATE | WEIGHT | SHEET |
| | | | | |

| REVISIONS | | |
|-----------|-----|------------|
| ZONE | REV | FINISHES: |
| | | 630 |
| | | GAUGE: |
| | | 12ga. .104 |

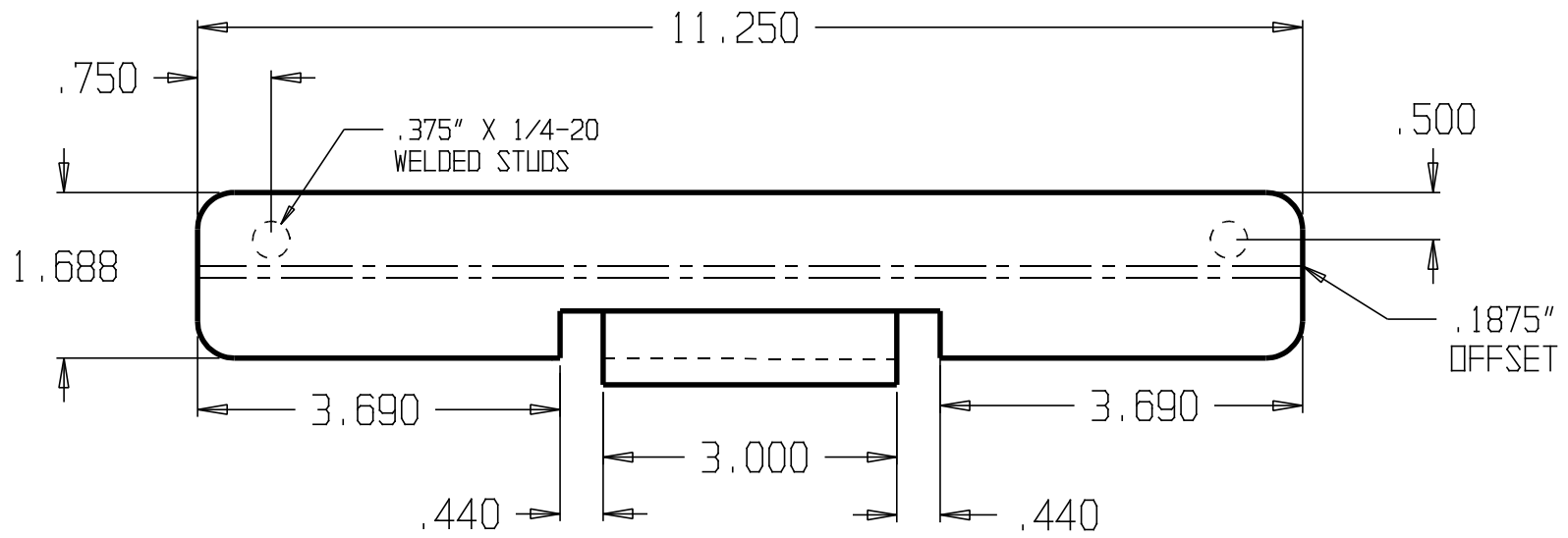

DON-JO MFG. INC.

| | | | | |
|----------|-------|--------------|----------|-------|
| DESIGNER | SIZE | DATE: | PART NO. | REV |
| | A | 5/19/04 | FLP-111 | |
| APPROVED | SCALE | RELEASE DATE | WEIGHT | SHEET |
| | | | | |

| REVISIONS | | |
|-----------|-----|------------|
| ZONE | REV | FINISHES: |
| | | BP & DU |
| | | GAUGE: |
| | | 12ga. .104 |

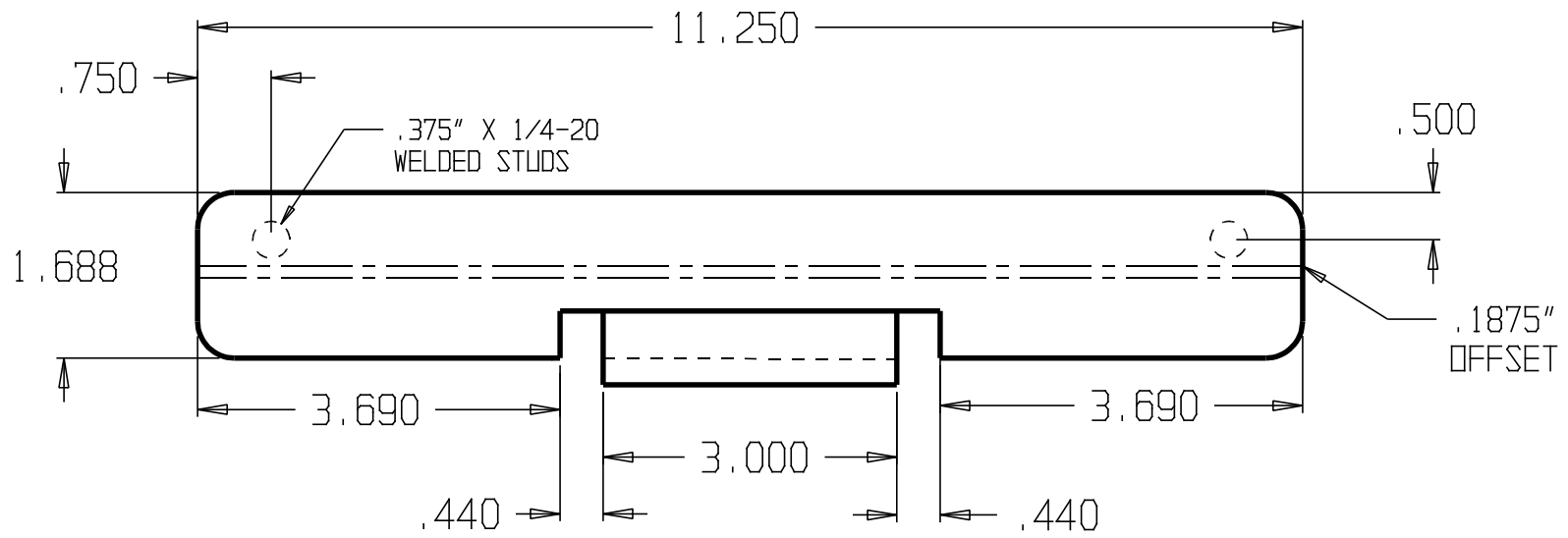

DON-JO MFG. INC.

| | | | | |
|----------|-------|--------------|----------|-------|
| DESIGNER | SIZE | DATE: | PART NO. | REV |
| | A | 5/19/04 | FLP-211 | |
| APPROVED | SCALE | RELEASE DATE | WEIGHT | SHEET |
| | | | | |

| REVISIONS | | | |
|-----------|-----|--------------|------------|
| ZONE | REV | FINISHES: | GALVE: |
| | | 630, DU & SL | 12ga. .104 |

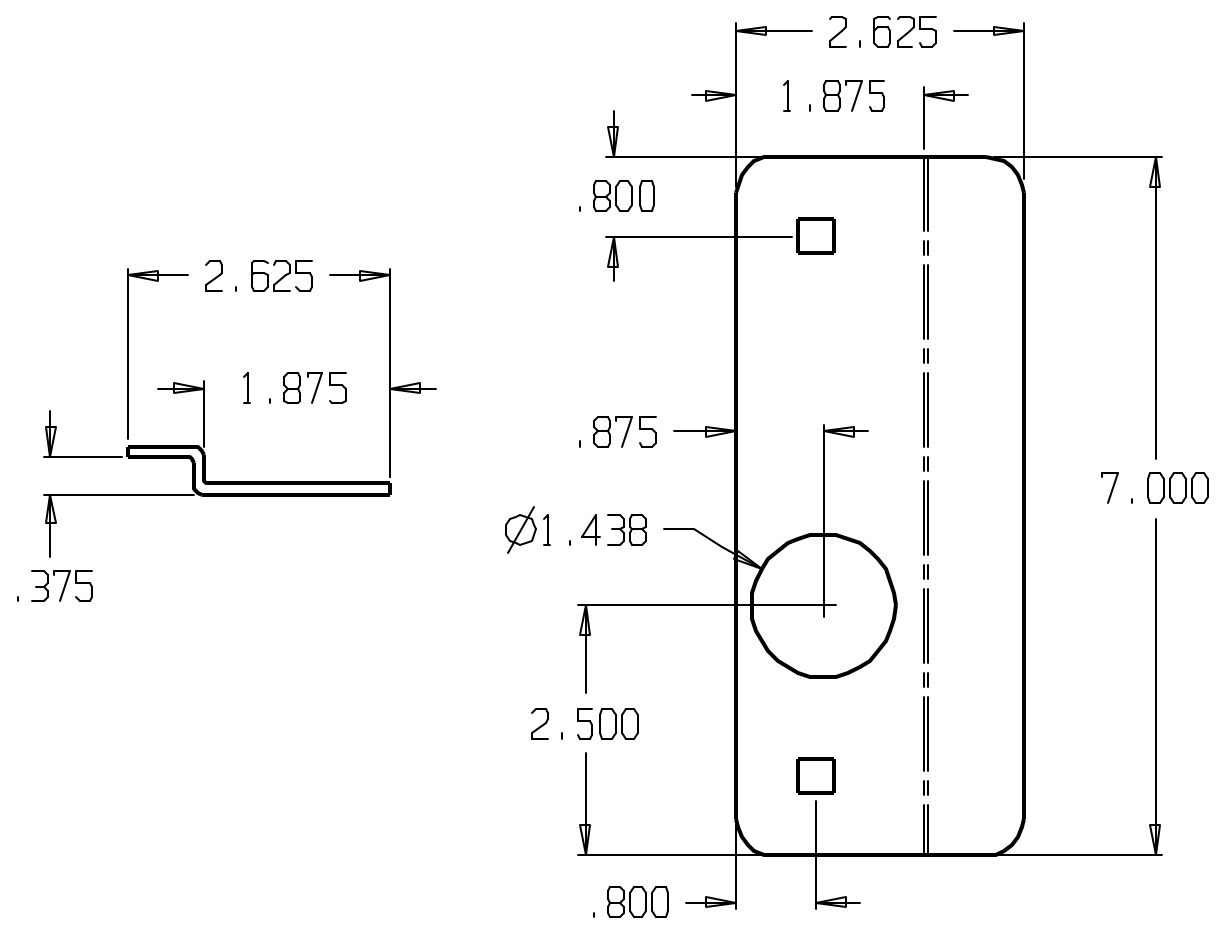

| | | | | | |
|------------------|--|-------|--------------|-------------|-------|
| DON-JO MFG. INC. | | SIZE | DATE | PART NO. | REV |
| DESIGNER | | A | 5/19/04 | GLP-307-LHR | |
| APPROVED | | SCALE | RELEASE DATE | WEIGHT | SHEET |

| REVISIONS | | | |
|-----------|-----|--------------|------------|
| ZONE | REV | FINISHES: | GALVE: |
| | | 630, DU & SL | 12ga. .104 |

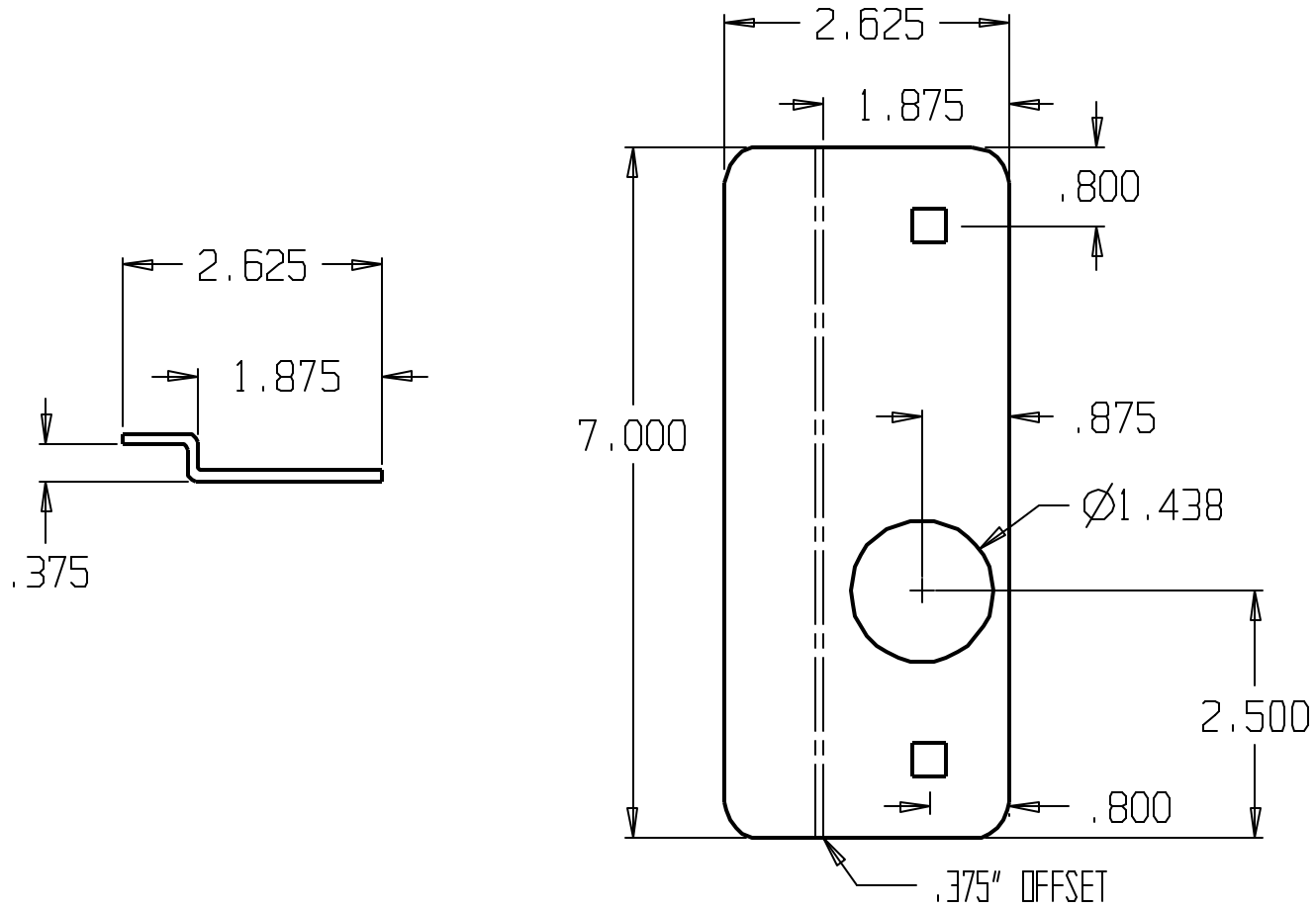

| | | | | | |
|------------------|--|-------|--------------|-------------|-------|
| DON-JO MFG. INC. | | SIZE | DATE | PART NO. | REV |
| DESIGNER | | A | 5/19/04 | GLP-307-RHR | |
| APPROVED | | SCALE | RELEASE DATE | WEIGHT | SHEET |

| REVISIONS | | | |
|-----------|-----|-------------|------------|
| ZONE | REV | FINISHES: | GAUGE: |
| | | BP, DU & SL | 14ga. .075 |

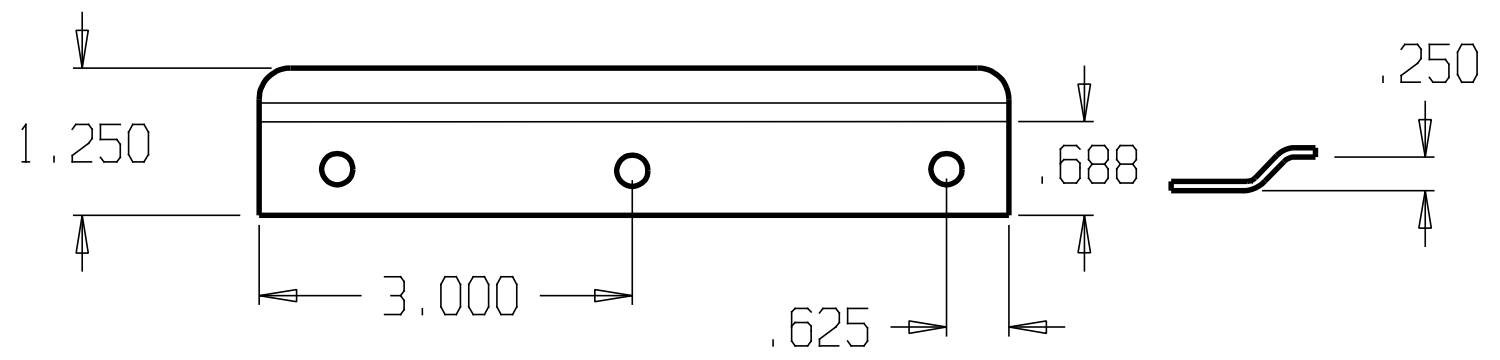
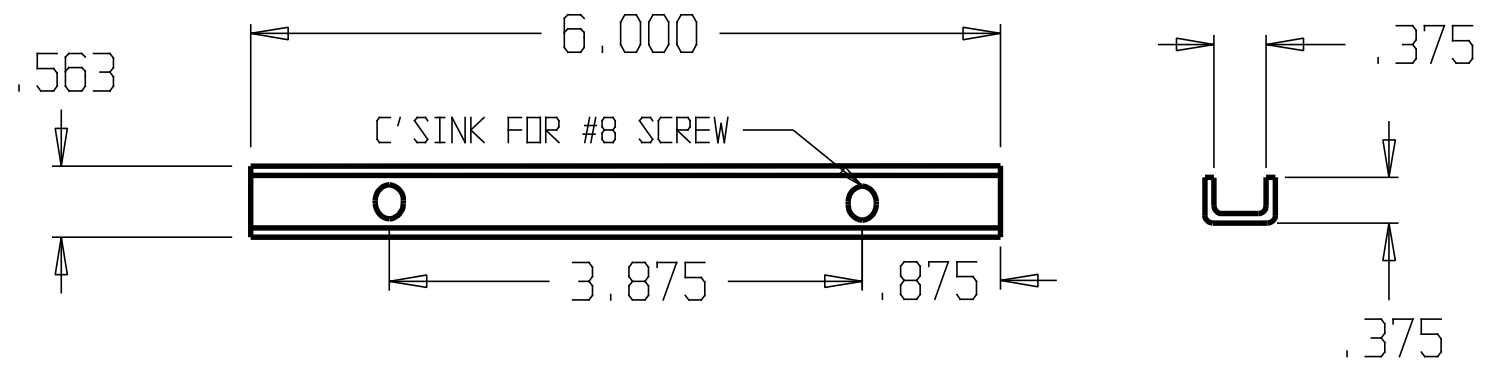

| | | | | | |
|------------------|--|-------|--------------|----------|-------|
| DON-JO MFG. INC. | | SIZE | DATE: | PART NO. | REV |
| DESIGNER | | A | 5/28/04 | ILP-206 | |
| APPROVED | | SCALE | RELEASE DATE | WEIGHT | SHEET |

| REVISIONS | | | |
|-----------|-----|-------------|------------|
| ZONE | REV | FINISHES: | GAUGE: |
| | | BP, DU & SL | 14ga. .075 |

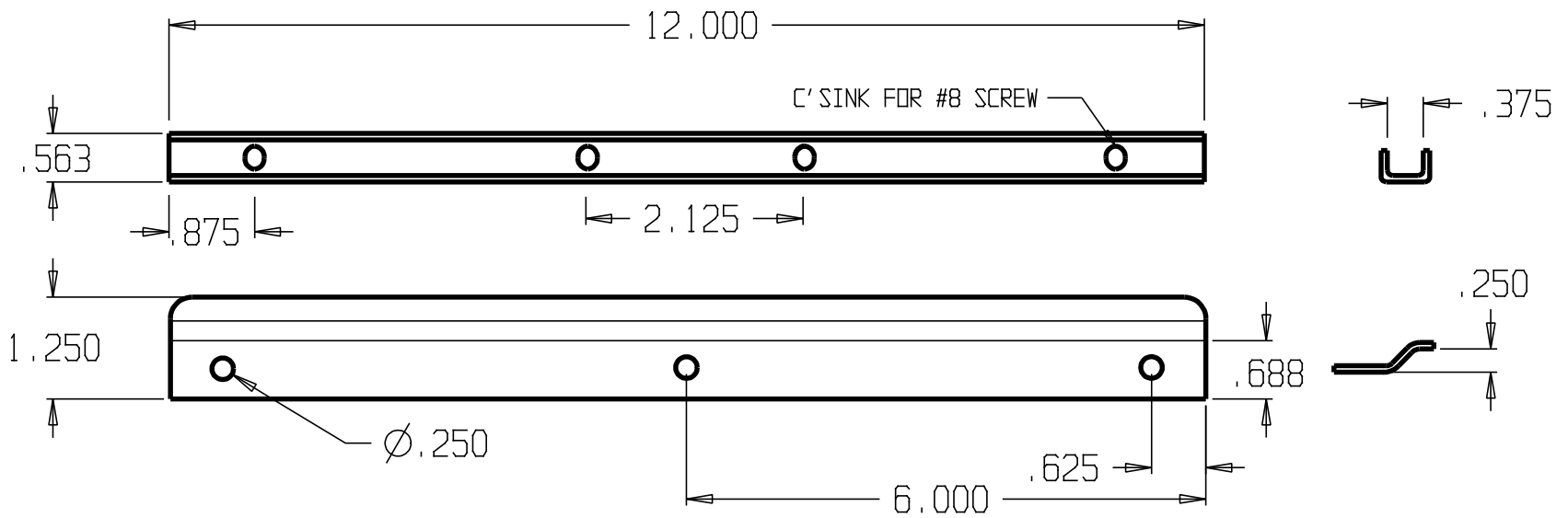

| | | | | | | | |
|------------------|--|-------|--------------|---------|-------|----------|-----|
| DON-JO MFG. INC. | | | | SIZE | DATE: | PART NO. | REV |
| DESIGNER | | A | 5/28/04 | ILP-212 | | | |
| APPROVED | | SCALE | RELEASE DATE | WEIGHT | SHEET | | |

| REVISIONS | | | |
|-----------|-----|-----------|------------|
| ZONE | REV | FINISHES: | GAUGE: |
| | | 630 | 12ga. .104 |

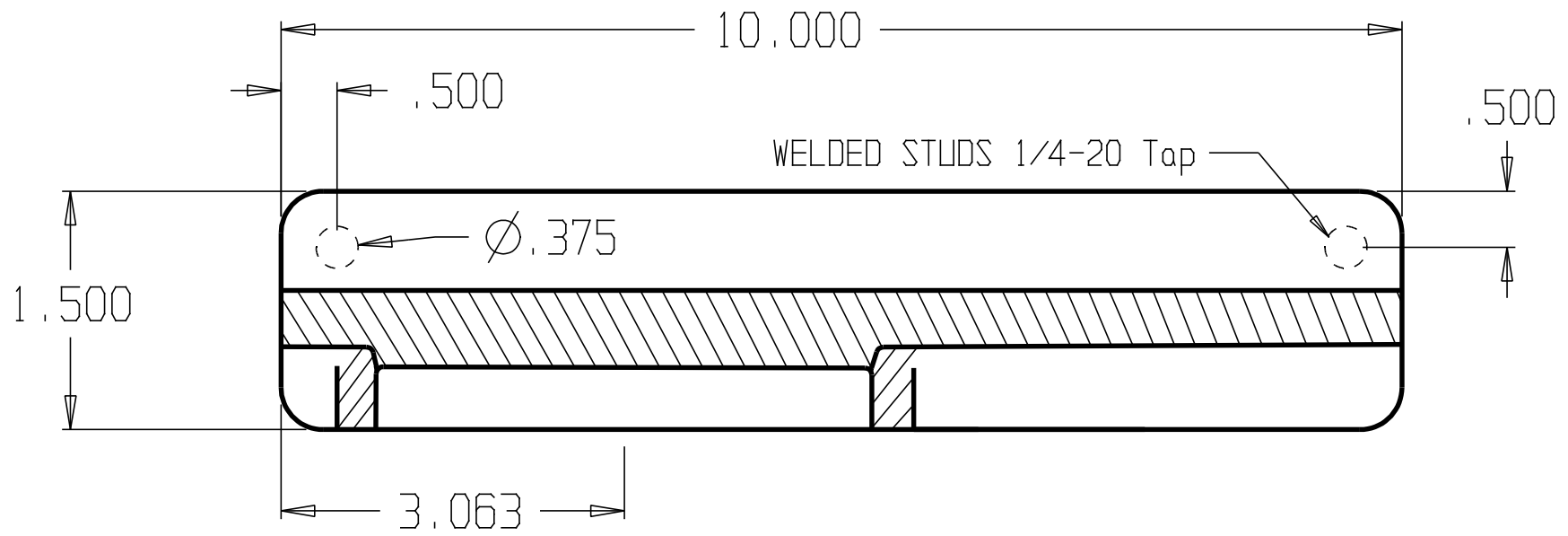

DON-JO MFG. INC.

| | |
|----------|--|
| DESIGNER | |
| APPROVED | |

| | | | |
|-------|--------------|-----------------|-------|
| SIZE | DATE: | PART NO. | REV |
| A | 6/10/04 | KLP-110-630-LHR | |
| SCALE | RELEASE DATE | WEIGHT | SHEET |
| | | | |

| REVISIONS | | |
|-----------|-----|------------|
| ZONE | REV | FINISHES: |
| | | 630 |
| | | GAUGE: |
| | | 12ga. .104 |

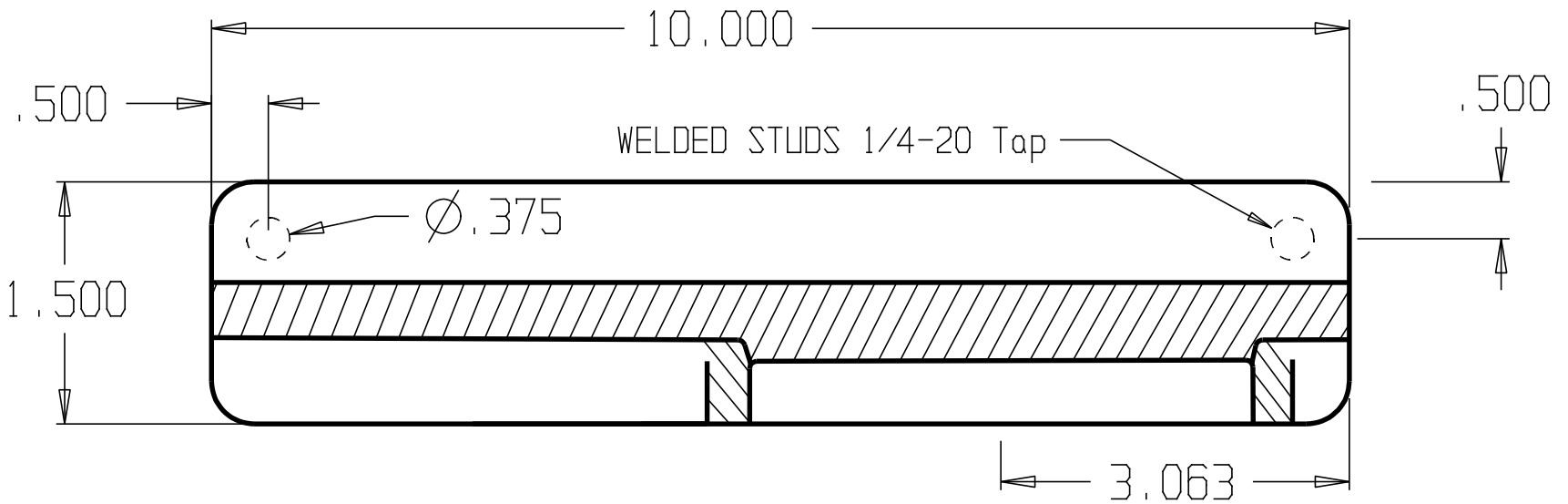

DON-JO MFG. INC.

| | | | | |
|----------|-------|--------------|-----------------|-------|
| DESIGNER | SIZE | DATE: | PART NO. | REV |
| | A | 6/10/04 | KLP-110-630-RHR | |
| APPROVED | SCALE | RELEASE DATE | WEIGHT | SHEET |
| | | | | |

| REVISIONS | | | |
|-----------|-----|-------------|------------|
| ZONE | REV | FINISHES: | GAUGE: |
| | | BP, DU & SL | 12ga. .104 |

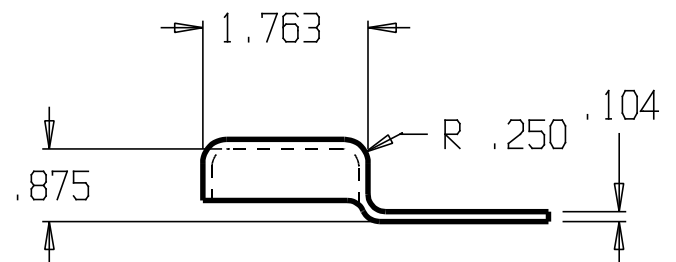
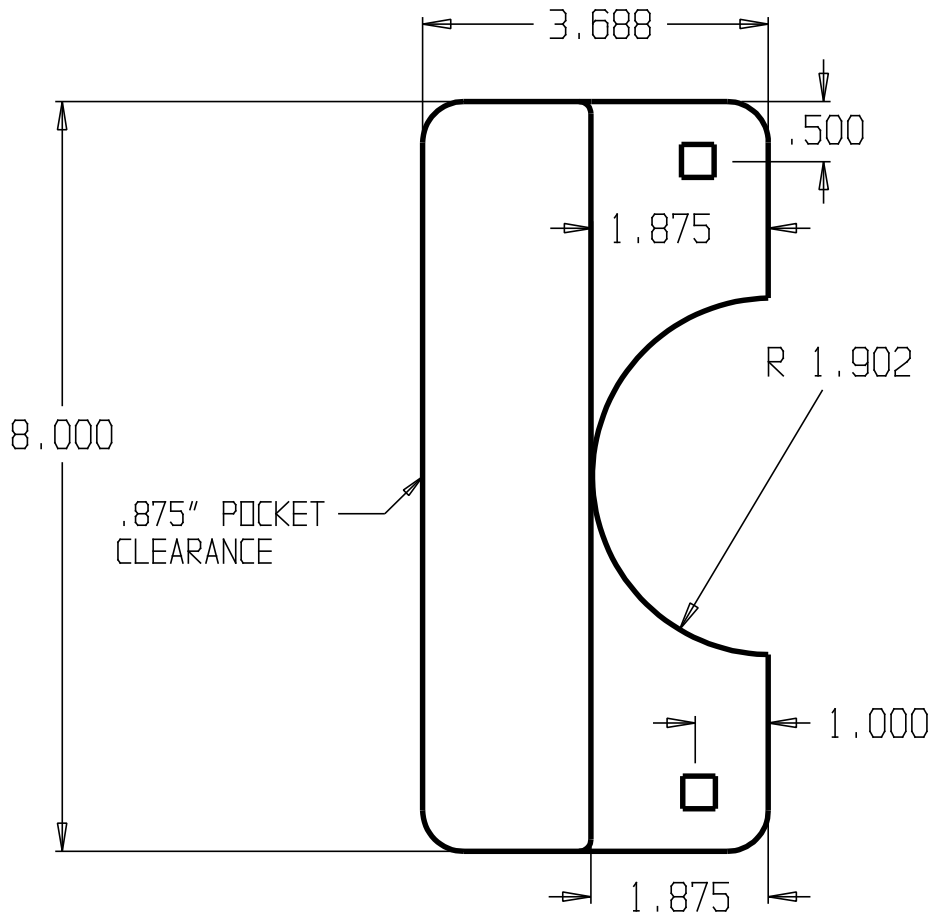

DON-JO MFG. INC.

| | | | | |
|----------|--------------|---------------|-------------------|-----|
| DESIGNER | SCALE | DATE: 6/13/04 | PART NO. LELP-208 | REV |
| APPROVED | RELEASE DATE | WEIGHT | SHEET | |

| REVISIONS | | | |
|-----------|-----|-------------|------------|
| ZONE | REV | FINISHES: | GAUGE: |
| | | BP, DU & SL | 12ga. .104 |

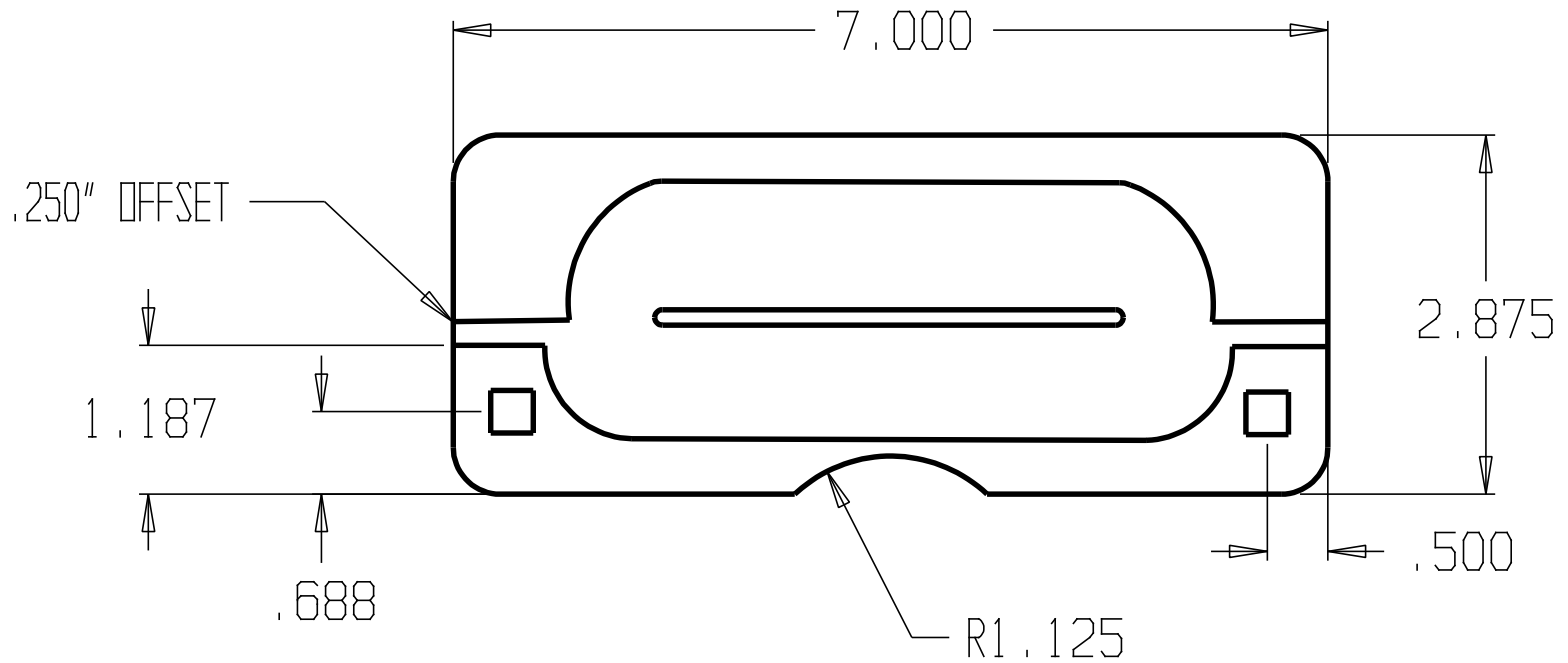

| | | | | | | | |
|------------------|--|-------|--------------|--------|-------|----------|-----|
| DON-JO MFG. INC. | | | | SIZE | DATE: | PART NO. | REV |
| DESIGNER | | A | 5/28/04 | LP-207 | | | |
| APPROVED | | SCALE | RELEASE DATE | WEIGHT | SHEET | | |

| REVISIONS | | |
|-----------|-----|------------------|
| ZONE | REV | FINISHES: |
| | | 626, BP, DU & SL |
| | | GAUGE: |
| | | 12ga. .104 |

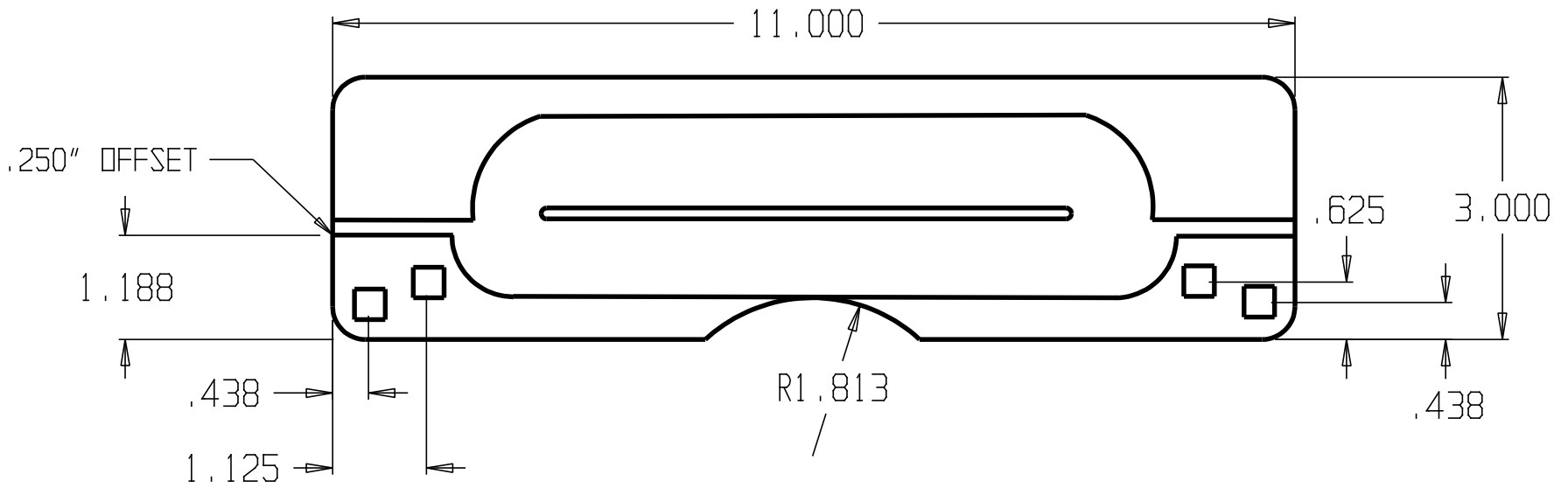

DON-JO MFG. INC.

| | | | | |
|----------|-------|--------------|----------|-------|
| DESIGNER | SIZE | DATE: | PART NO. | REV |
| | A | 5/28/04 | LP-211 | |
| APPROVED | SCALE | RELEASE DATE | WEIGHT | SHEET |
| | | | | |

| REVISIONS | | |
|-----------|-----|------------------|
| ZONE | REV | FINISHES: |
| | | 626, BP, DU & SL |
| | | GAUGE: |
| | | 12ga. .104 |

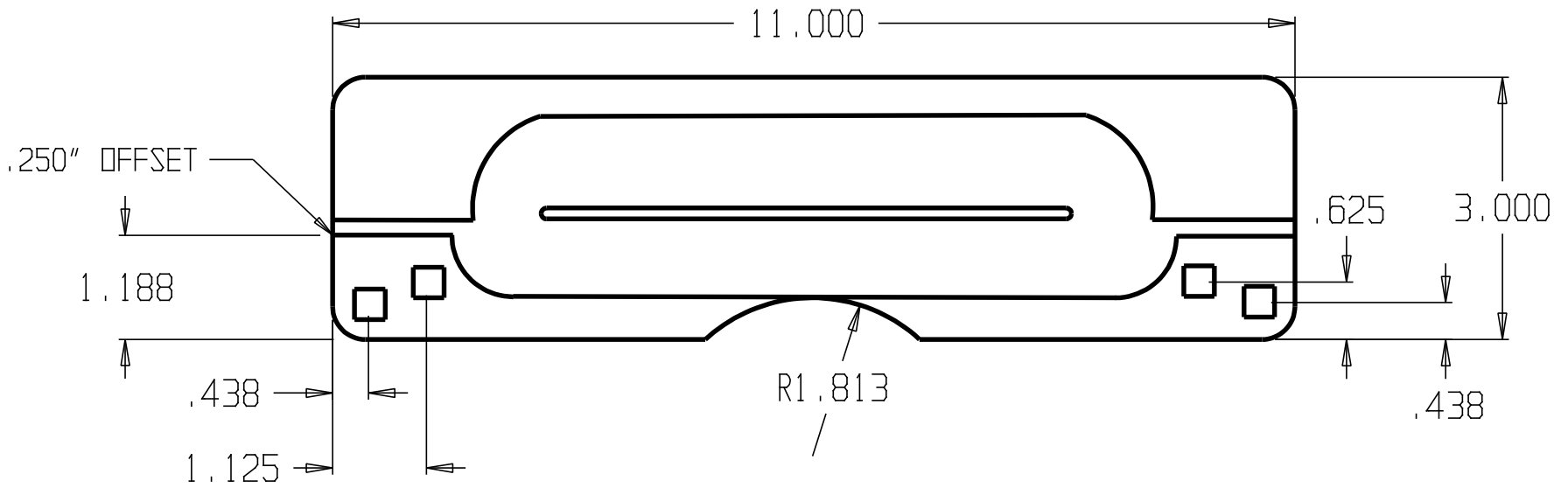

| | | | | | |
|------------------|--|-------|--------------|----------|-------|
| DON-JO MFG. INC. | | SIZE | DATE: | PART NO. | REV |
| DESIGNER | | A | 5/28/04 | LP-211 | |
| APPROVED | | SCALE | RELEASE DATE | WEIGHT | SHEET |

| REVISIONS | | |
|-----------|-----|-------------|
| ZONE | REV | FINISHES: |
| | | DU, PC & SL |
| | | GALUGE: |
| | | .3125" |

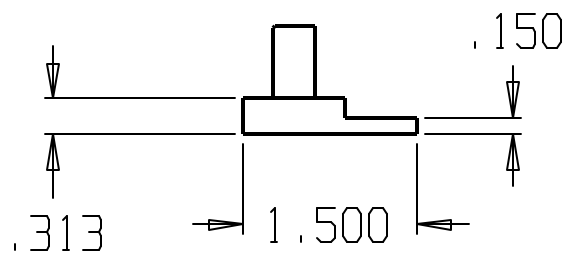
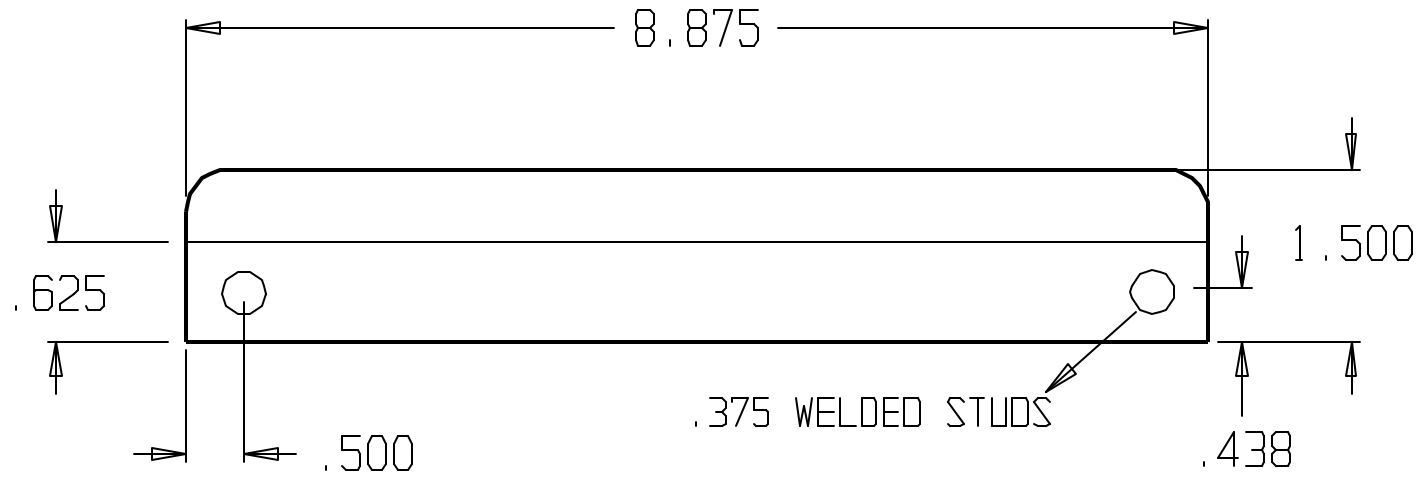

DON-JO MFG. INC.

| | | | | |
|----------|-------|--------------|----------|-------|
| DESIGNER | SIZE | DATE: | PART NO. | REV |
| | A | 5/28/04 | LP-2878 | |
| APPROVED | SCALE | RELEASE DATE | WEIGHT | SHEET |
| | | | | |

| REVISIONS | | | |
|-----------|-----|--------------|------------|
| ZONE | REV | FINISHES: | GAUGE: |
| | | DU, SL & 630 | 12ga. .104 |

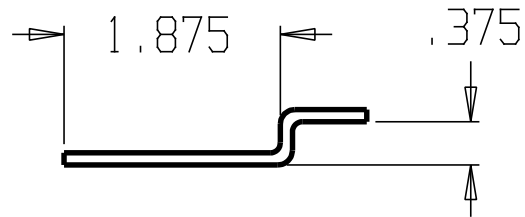
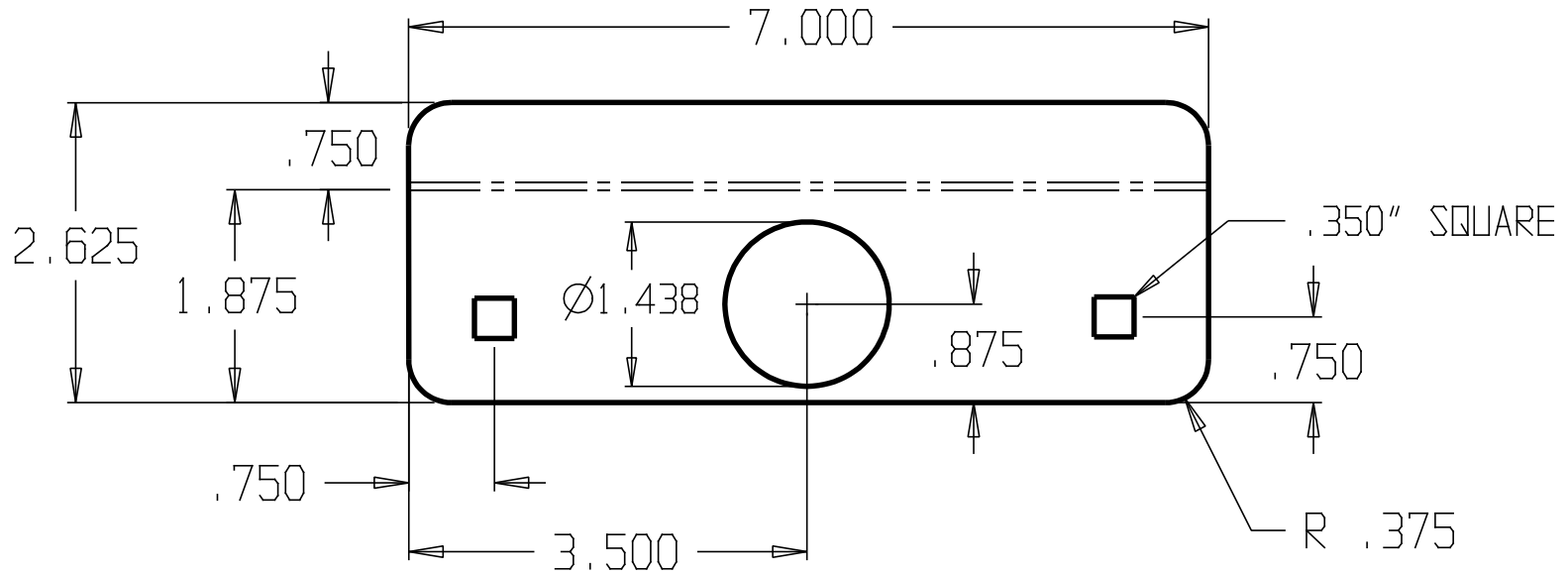

DON-JO MFG. INC.

| | | | | |
|----------|-------|--------------|----------|-------|
| DESIGNER | SIZE | DATE: | PART NO. | REV |
| | A | 5/28/04 | LP-307 | |
| APPROVED | SCALE | RELEASE DATE | WEIGHT | SHEET |
| | | | | |

| REVISIONS | | | |
|-----------|-----|-----------|------------|
| ZONE | REV | FINISHES: | GAUGE: |
| | | DU & SL | 12ga. .104 |

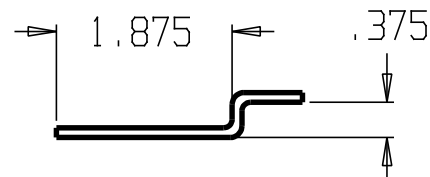
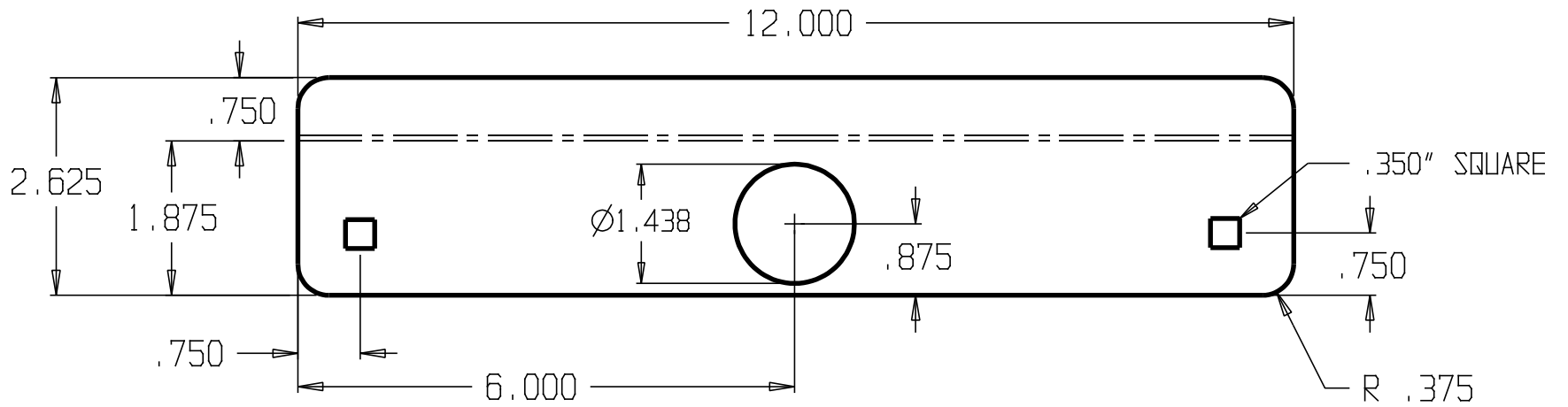

DON-JO MFG. INC.

| | | | | |
|----------|-------|--------------|----------|-------|
| DESIGNER | SIZE | DATE: | PART NO. | REV |
| | A | 6/3/04 | LP-312 | |
| APPROVED | SCALE | RELEASE DATE | WEIGHT | SHEET |
| | | | | |

| REVISIONS | | | |
|-----------|-----|-----------|------------|
| ZONE | REV | FINISHES: | GAUGE: |
| | | DU & SL | 12ga. .104 |

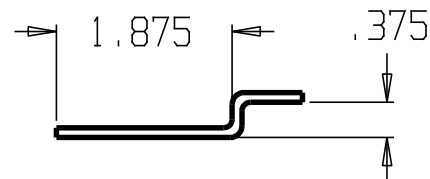
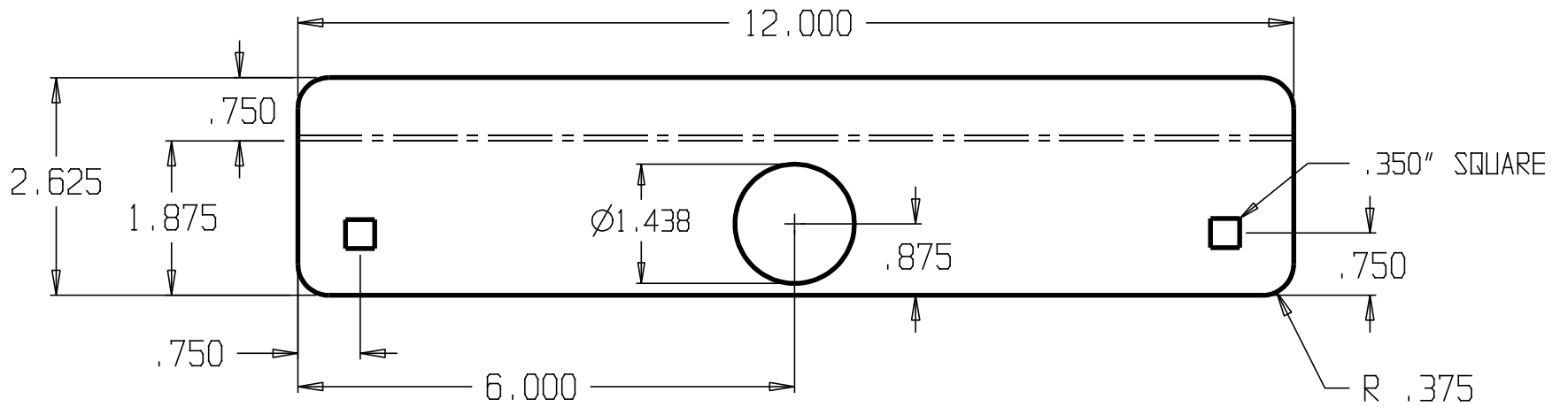

DON-JO MFG. INC.

| | | | | |
|----------|-------|--------------|----------|-------|
| DESIGNER | SIZE | DATE: | PART NO. | REV |
| | A | 6/3/04 | LP-312 | |
| APPROVED | SCALE | RELEASE DATE | WEIGHT | SHEET |
| | | | | |

| REVISIONS | | | |
|-----------|-----|-----------|------------|
| ZONE | REV | FINISHES: | GAUGE: |
| | | DU & SL | 12ga. .104 |

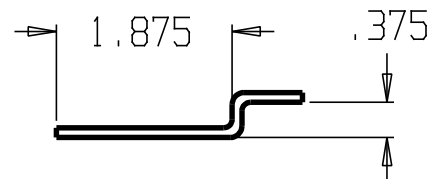
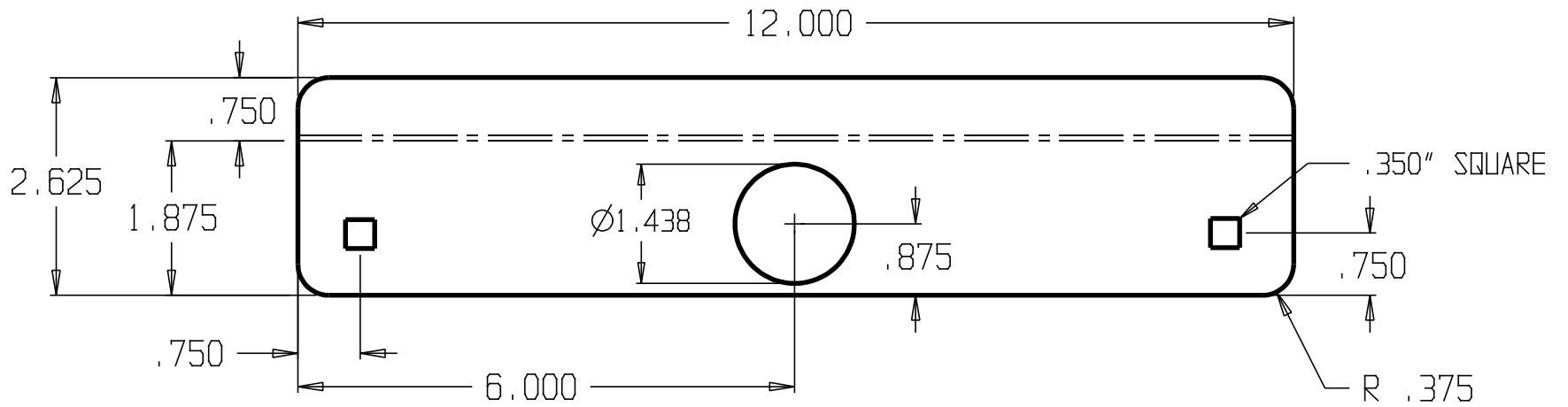

DON-JO MFG. INC.

| | | | | |
|----------|-------|--------------|----------|-------|
| DESIGNER | SIZE | DATE: | PART NO. | REV |
| | A | 6/3/04 | LP-312 | |
| APPROVED | SCALE | RELEASE DATE | WEIGHT | SHEET |
| | | | | |

| REVISIONS | | |
|-----------|-----|------------|
| ZONE | REV | FINISHES: |
| | | DU & SL |
| | | GAUGE: |
| | | 12ga. .104 |

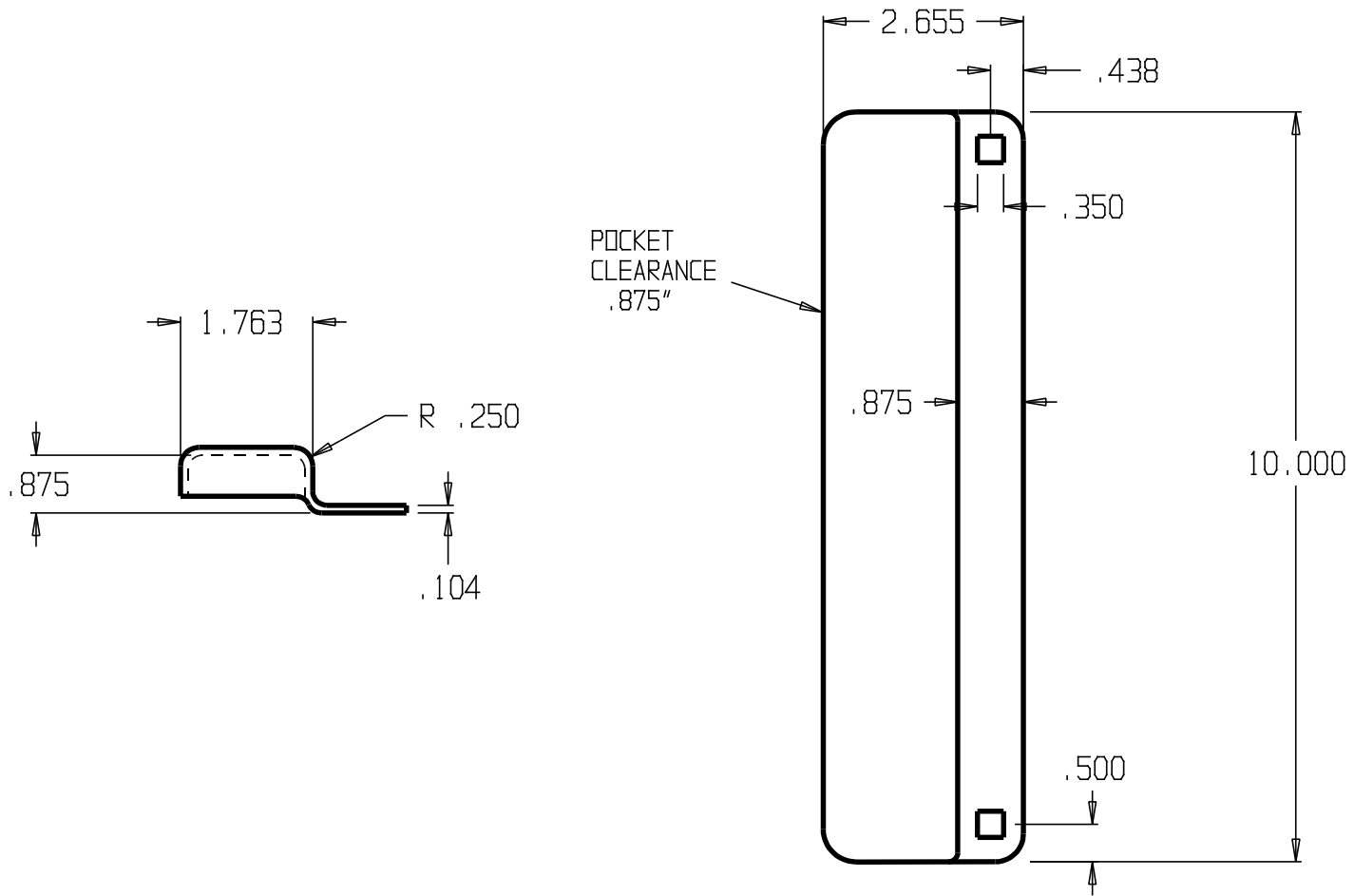

| | | | | | | | |
|------------------|--|-------|--------------|----------|-------|----------|-----|
| DON-JO MFG. INC. | | | | SIZE | DATE: | PART NO. | REV |
| DESIGNER | | A | 6/13/04 | MELP-210 | | | |
| APPROVED | | SCALE | RELEASE DATE | WEIGHT | SHEET | | |

| REVISIONS | | |
|-----------|-----|------------|
| ZONE | REV | FINISHES: |
| | | DU & SL |
| | | GAUGE: |
| | | 12ga. .104 |

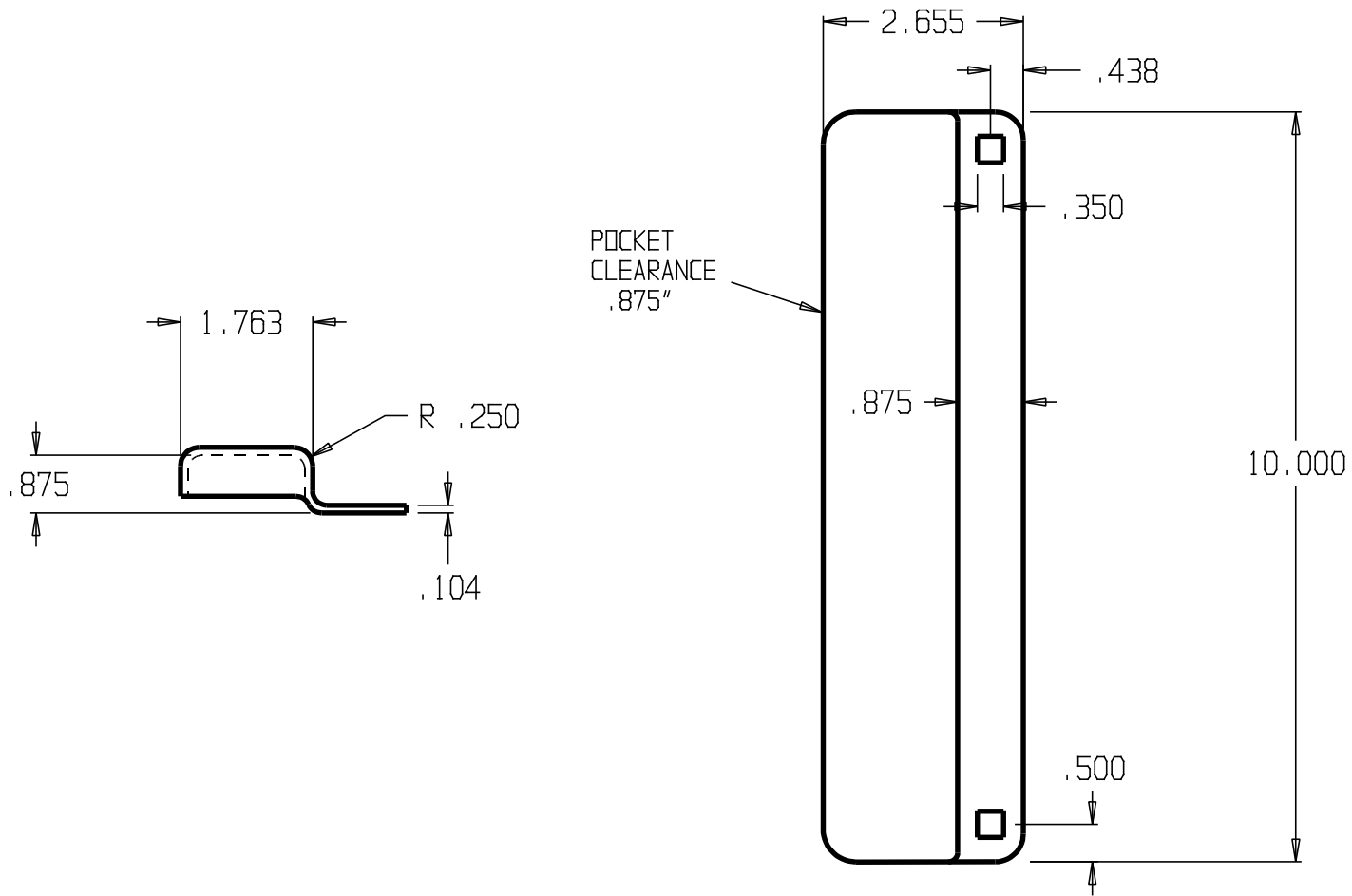

| | | | |
|------------------|-----------|------------------|----------------------|
| DON-JO MFG. INC. | | | |
| DESIGNER | SIZE A | DATE: 6/13/04 | PART NO. MELP-210 |
| APPROVED | SCALE | RELEASE DATE | WEIGHT |
| | | | SHEET |

| REVISIONS | | | |
|-----------|-----|-----------|------------|
| ZONE | REV | FINISHES: | GAUGE: |
| | | 630 | 12ga. .104 |

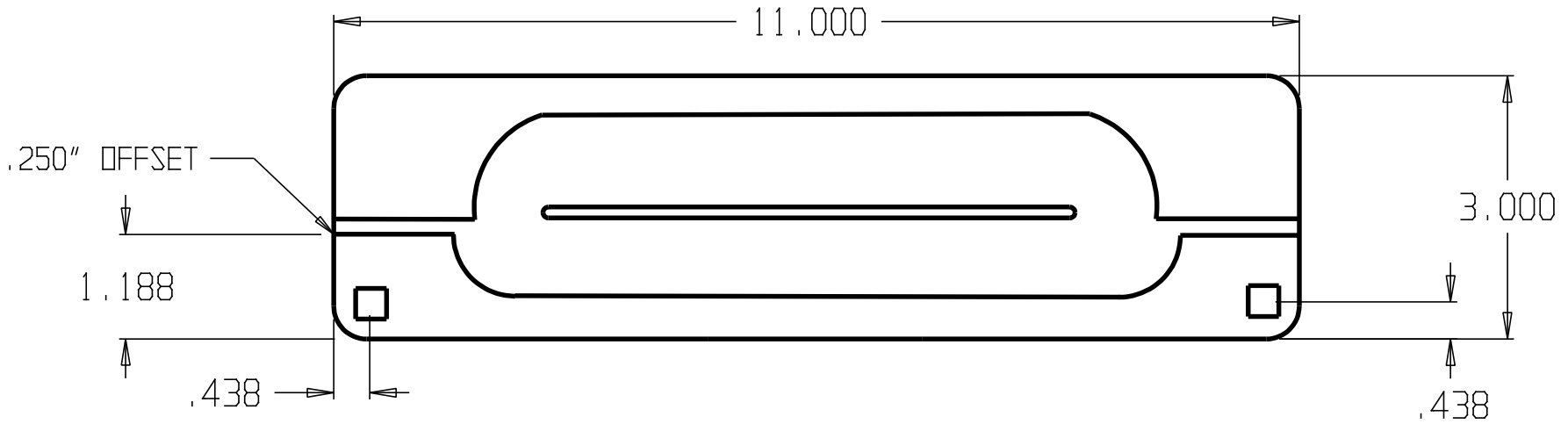

DON-JO MFG. INC.

| | |
|----------|--|
| DESIGNER | |
| APPROVED | |

| | | | |
|-------|--------------|----------|-------|
| SIZE | DATE: | PART NO. | REV |
| A | 5/28/04 | MLP-111 | |
| SCALE | RELEASE DATE | WEIGHT | SHEET |
| | | | |

| | | |
|--------|----|-----|
| DWG NO | SH | REV |
|--------|----|-----|

| REVISIONS | | | |
|-----------|-----|-------------|------------|
| ZONE | REV | FINISHES: | GAUGE: |
| | | BP, DU & SL | 12ga. .104 |

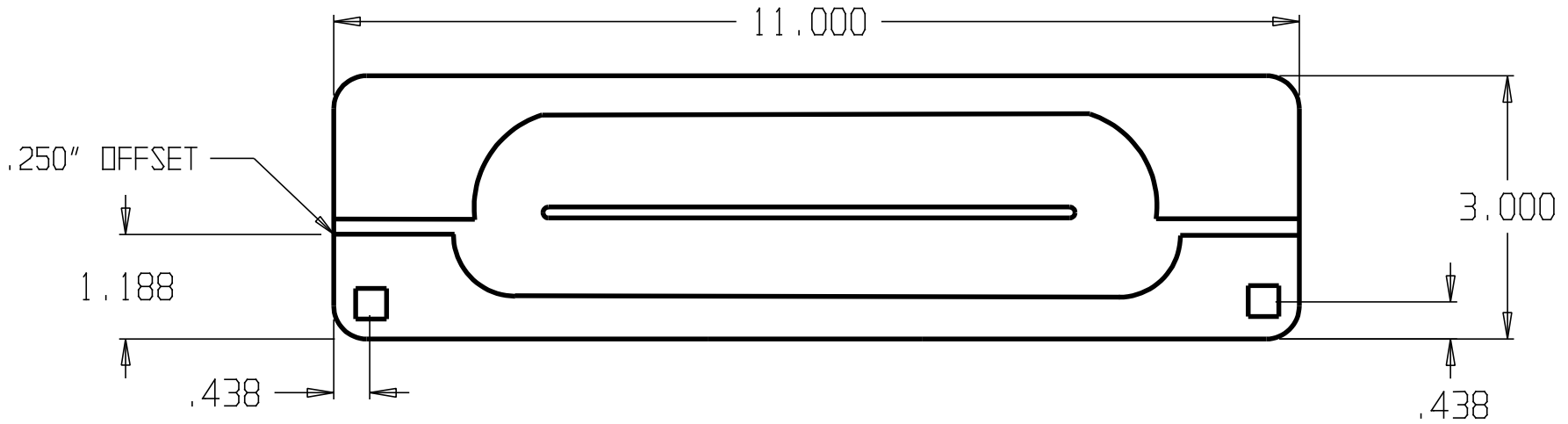

DON-JO MFG. INC.

DESIGNER

APPROVED

| | | | |
|-----------|------------------|---------------------|-------|
| SIZE A | DATE: 5/28/04 | PART NO. MLP-211 | REV |
| SCALE | RELEASE DATE | WEIGHT | SHEET |

| | | |
|---------|----|-----|
| DWG NO. | SH | REV |
|---------|----|-----|

| REVISIONS | | |
|-----------|-----|------------|
| ZONE | REV | FINISHES: |
| | | DU & SL |
| | | GALUGE: |
| | | 12ga. .104 |

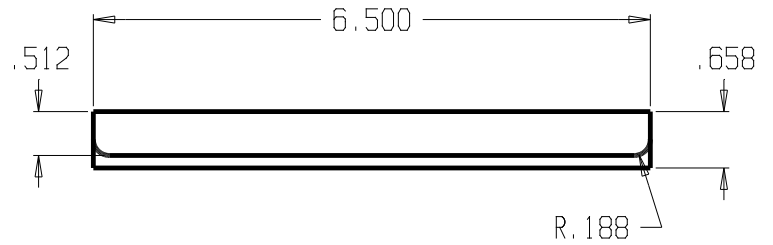
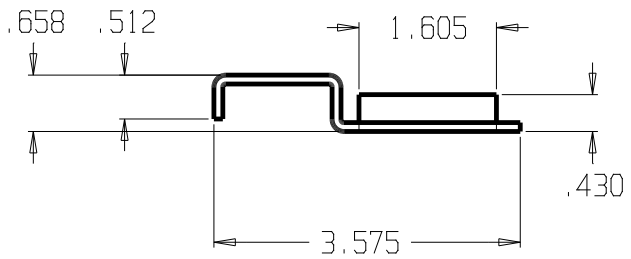
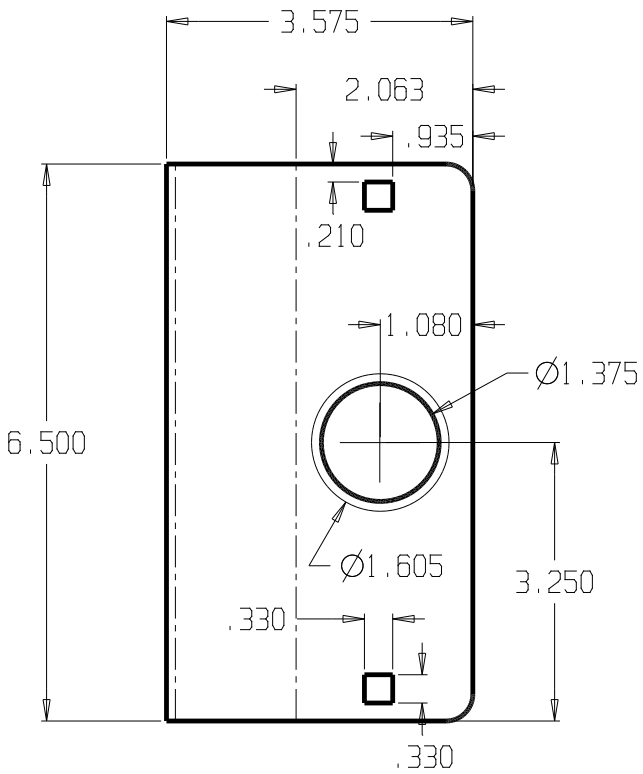

| | |
|------------------|------|
| DON-JO MFG. INC. | |
| DESIGNER | D.R. |

| | | | |
|-------|--------------|----------|-------|
| SIZE | DATE: | PART NO. | REV |
| A | 4/1/11 | NELP-207 | |
| SCALE | RELEASE DATE | WEIGHT | SHEET |
| | | | |

| REVISIONS | | | |
|-----------|-----|-----------|------------|
| ZONE | REV | FINISHES: | GAUGE: |
| | | 630 | 12ga. .104 |

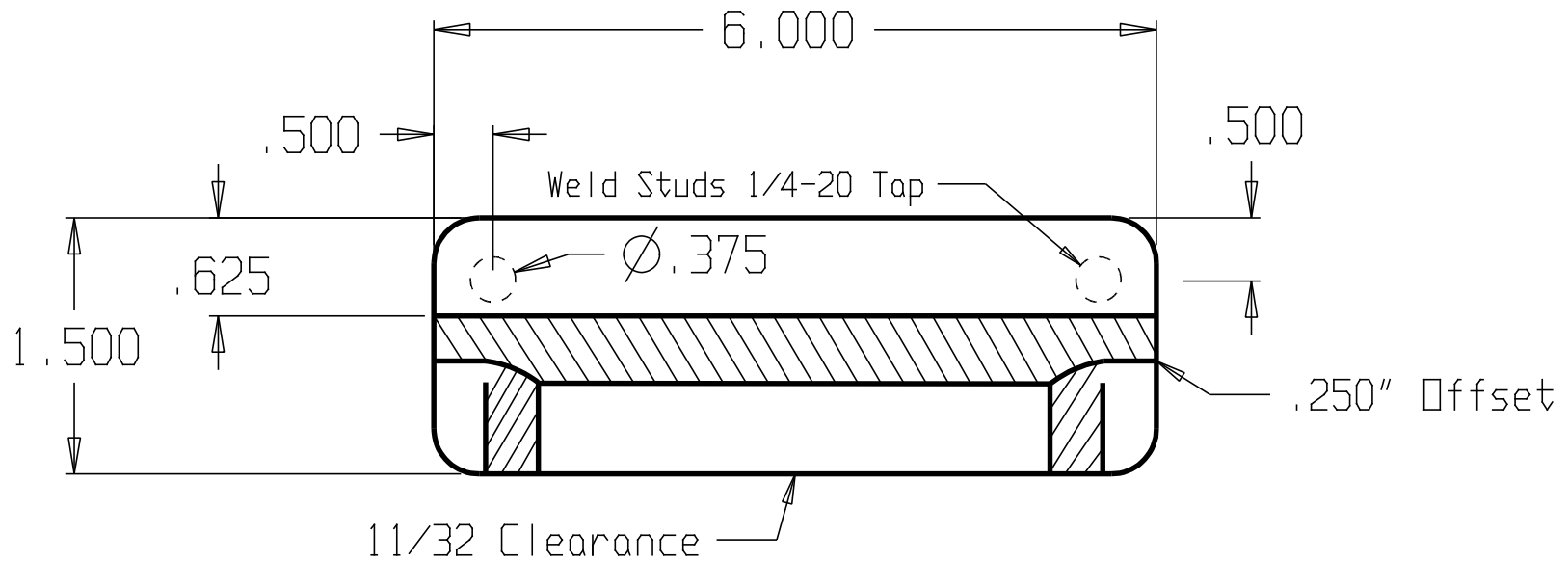

DON-JO MFG. INC.

| | | | | |
|----------|-------|--------------|----------|-------|
| DESIGNER | SIZE | DATE: | PART NO. | REV |
| | A | 6/3/04 | NLP-106 | |
| APPROVED | SCALE | RELEASE DATE | WEIGHT | SHEET |
| | | | | |

| REVISIONS | | | |
|-----------|-----|-----------|------------|
| ZONE | REV | FINISHES: | GAUGE: |
| | | 630 | 12ga. .104 |

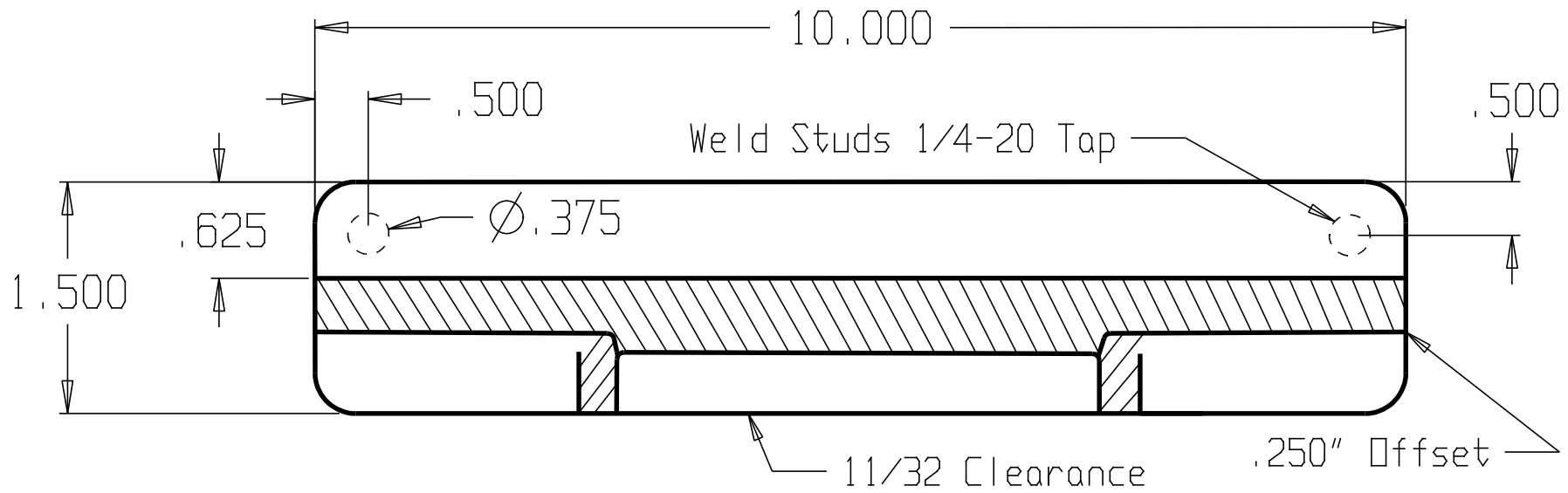

DON-JO MFG. INC.

| | |
|----------|--|
| DESIGNER | |
| APPROVED | |

| | | | |
|-------|--------------|----------|-------|
| SIZE | DATE: | PART NO. | REV |
| A | 5/6/04 | NLP-110 | |
| SCALE | RELEASE DATE | WEIGHT | SHEET |

| REVISIONS | | | |
|-----------|-----|-------------|------------|
| ZONE | REV | FINISHES: | GAUGE: |
| | | DU, PC & SL | 12ga. .104 |

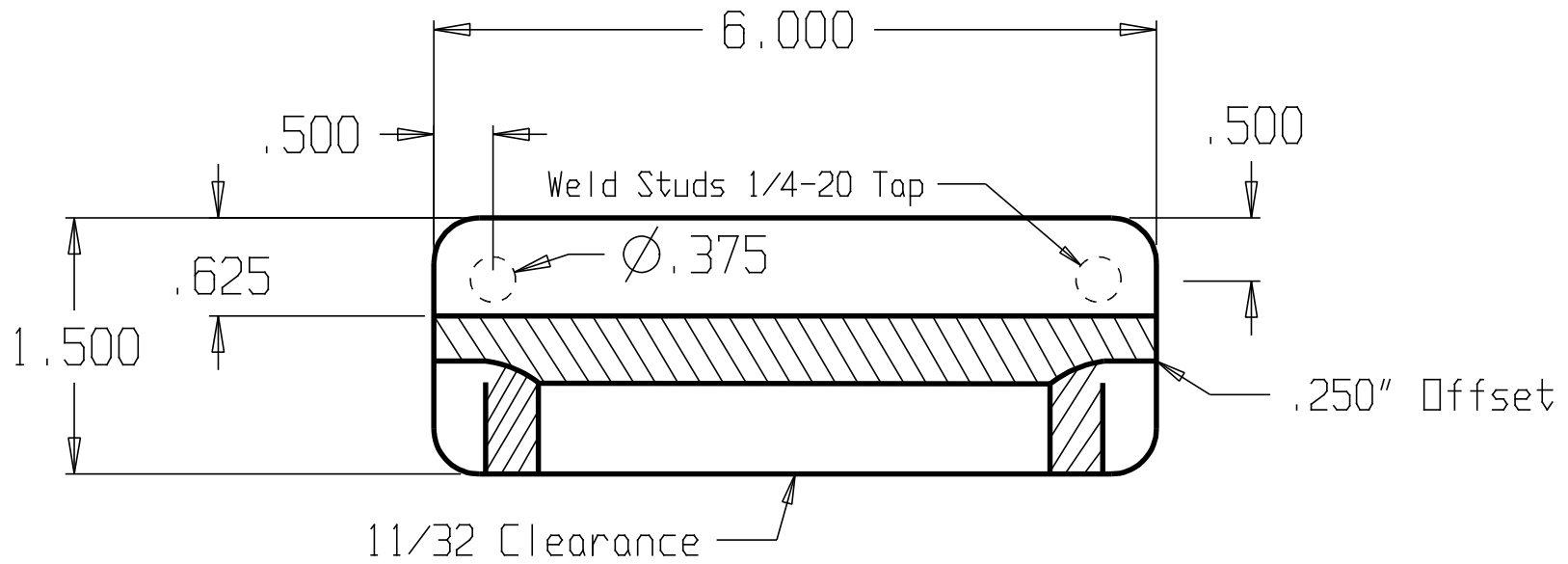

DON-JO MFG. INC.

| | | | | |
|----------|-------|--------------|----------|-------|
| DESIGNER | SIZE | DATE: | PART NO. | REV |
| | A | 6/3/04 | NLP-206 | |
| APPROVED | SCALE | RELEASE DATE | WEIGHT | SHEET |
| | | | | |

| REVISIONS | | |
|-----------|-----|-------------|
| ZONE | REV | FINISHES: |
| | | DU, PC & SL |
| | | GAUGE: |
| | | 12ga. .104 |

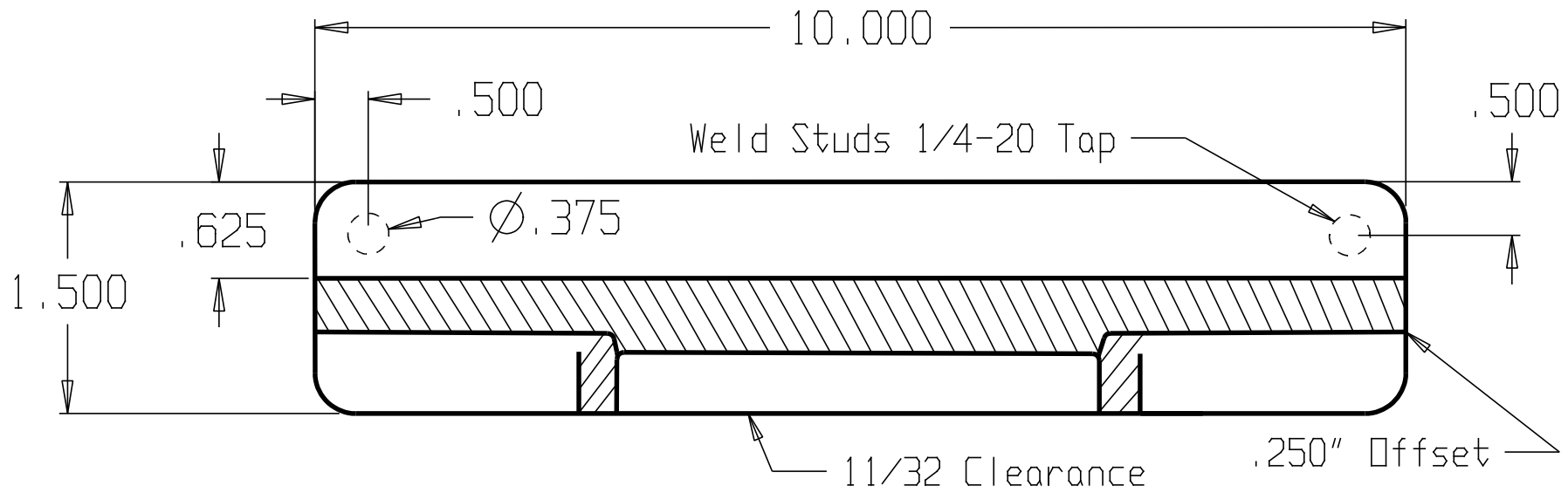

DON-JO MFG. INC.

DESIGNER

APPROVED

| | | | |
|-------|--------------|----------|-------|
| SIZE | DATE: | PART NO. | REV |
| A | 5/6/04 | NLP-210 | |
| SCALE | RELEASE DATE | WEIGHT | SHEET |

| REVISIONS | | | |
|-----------|-----|-----------|------------|
| ZONE | REV | FINISHES: | GAUGE: |
| | | DU & SL | 12ga. .104 |

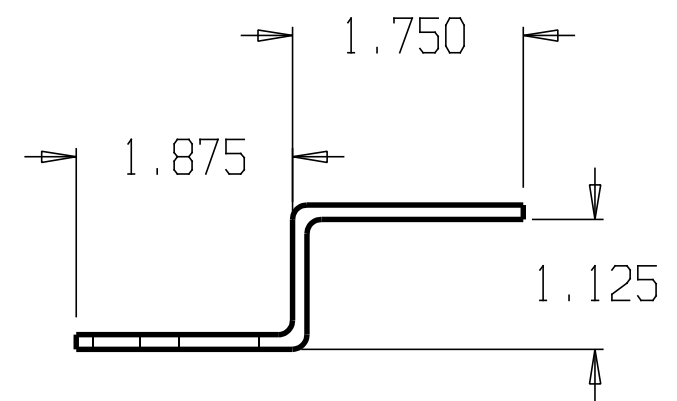
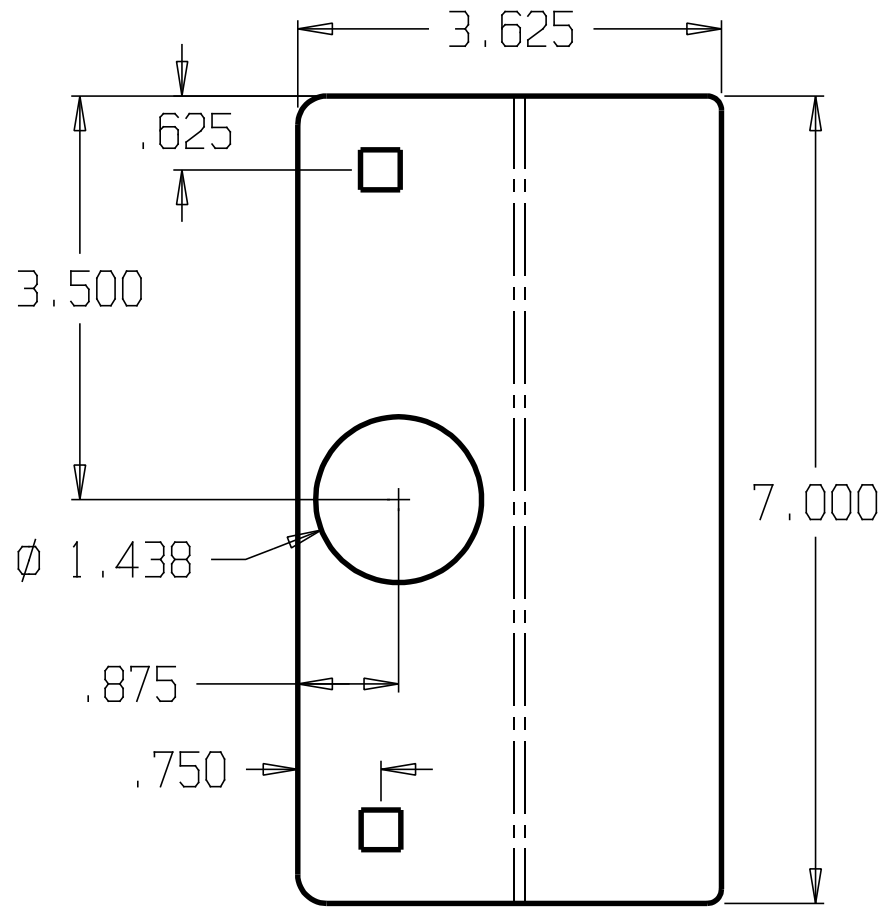

| | | | | | | | |
|------------------|--|-------|--------------|----------|-------|----------|-----|
| DON-JO MFG. INC. | | | | SIZE | DATE: | PART NO. | REV |
| DESIGNER | | A | 6/3/04 | OLP-2650 | | | |
| APPROVED | | SCALE | RELEASE DATE | WEIGHT | SHEET | | |

| REVISIONS | | | |
|-----------|-----|-----------|------------|
| ZONE | REV | FINISHES: | GALUGE: |
| | | DU & SL | 12ga. .104 |

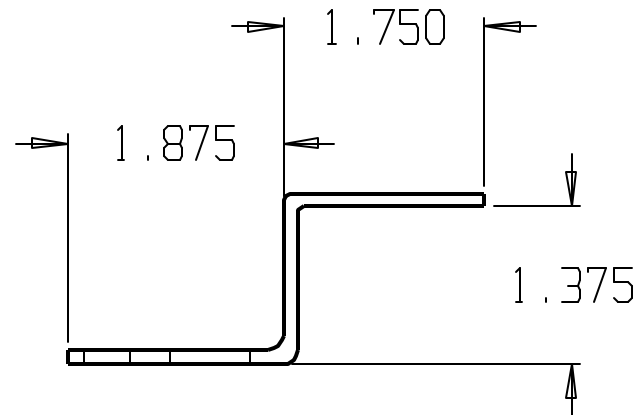
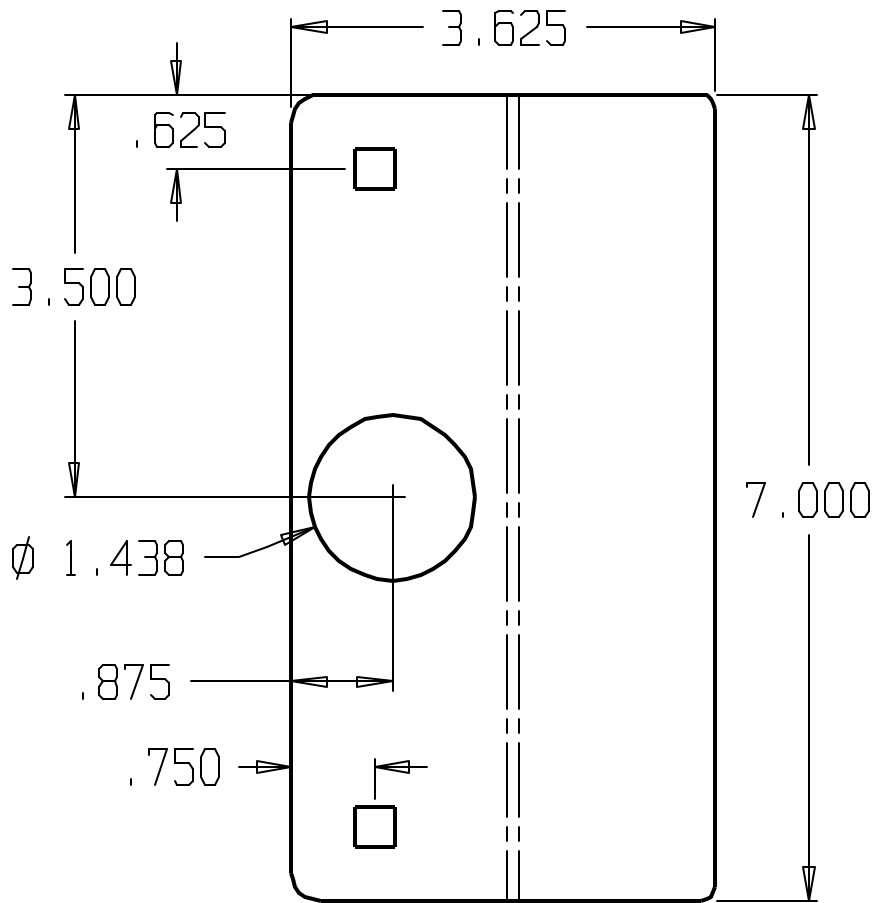

DON-JO MFG. INC.

| | |
|----------|--|
| DESIGNER | |
| APPROVED | |

| | | | |
|-----------|----------------|----------------------|-------|
| SIZE A | DATE 3/2/09 | PART NO. OLP-2651 | REV |
| SCALE | RELEASE DATE | WEIGHT | SHEET |

| REVISIONS | | | |
|-----------|-----|----------------------|------------|
| ZONE | REV | FINISHES: | GALUGE: |
| | | BP, CP, DU, SL & 630 | 12ga. .104 |

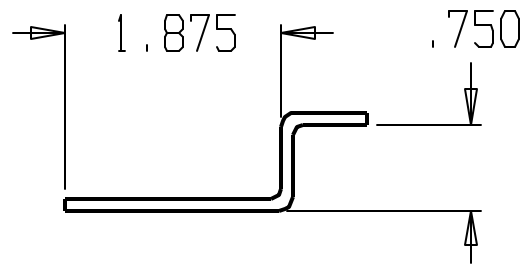
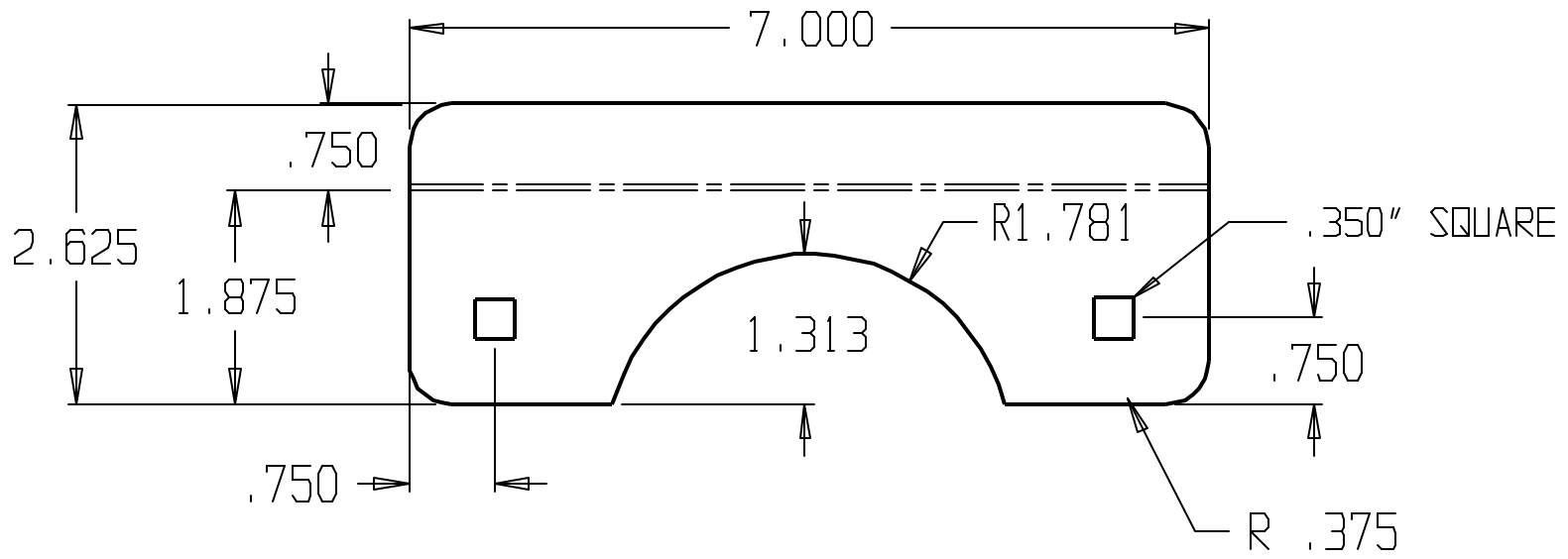

| | | | | | |
|------------------|--|-------|--------------|----------|-------|
| DON-JO MFG. INC. | | SIZE | DATE: | PART NO. | REV |
| DESIGNER | | A | 5/28/04 | OSLP-207 | |
| APPROVED | | SCALE | RELEASE DATE | WEIGHT | SHEET |

| REVISIONS | | |
|-----------|-----|----------------------|
| ZONE | REV | FINISHES: |
| | | BP, CP, DU, SL & 630 |
| | | GALUGE: |
| | | 12ga. .104 |

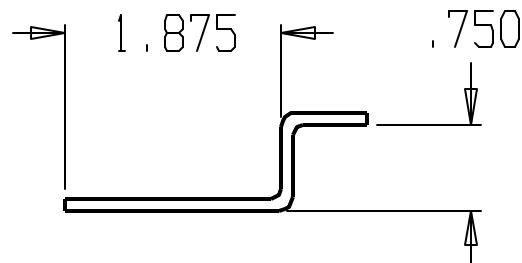
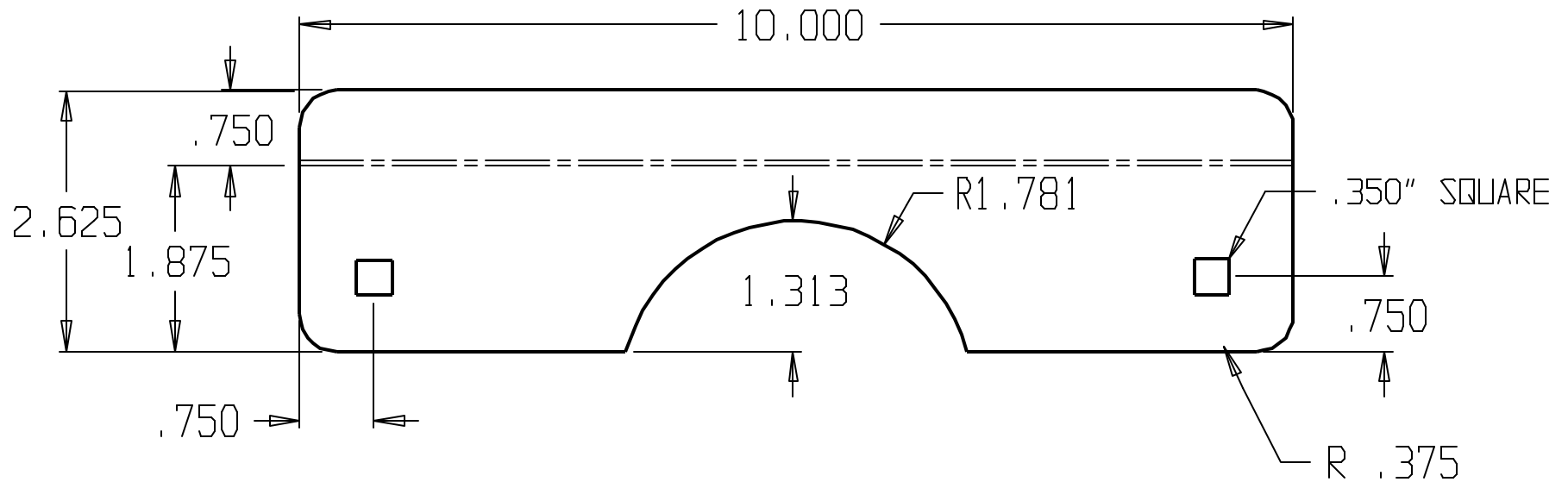

| | | | | | |
|------------------|--|-------|--------------|----------|-------|
| DON-JO MFG. INC. | | SIZE | DATE: | PART NO. | REV |
| DESIGNER | | A | 5/28/04 | OSLP-210 | |
| APPROVED | | SCALE | RELEASE DATE | WEIGHT | SHEET |

| REVISIONS | | | |
|-----------|-----|----------------------|------------|
| ZONE | REV | FINISHES: | GALUGE: |
| | | BP, CP, DU, SL & 630 | 12ga. .104 |

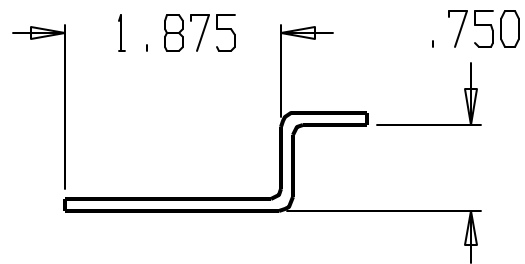
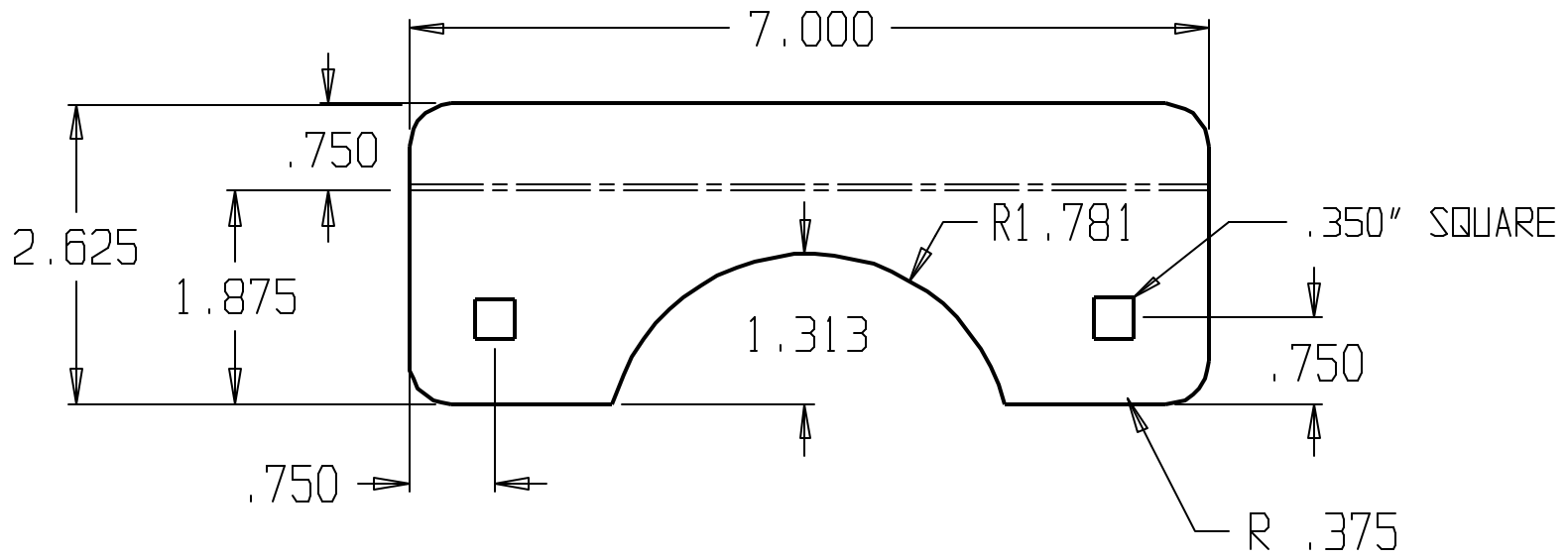

| | | | | | |
|------------------|--|-------|--------------|----------|-------|
| DON-JO MFG. INC. | | SIZE | DATE: | PART NO. | REV |
| DESIGNER | | A | 5/28/04 | OSLP-207 | |
| APPROVED | | SCALE | RELEASE DATE | WEIGHT | SHEET |

| REVISIONS | | | |
|-----------|-----|----------------------|------------|
| ZONE | REV | FINISHES: | GALUGE: |
| | | BP, CP, DU, SL & 630 | 12ga. .104 |

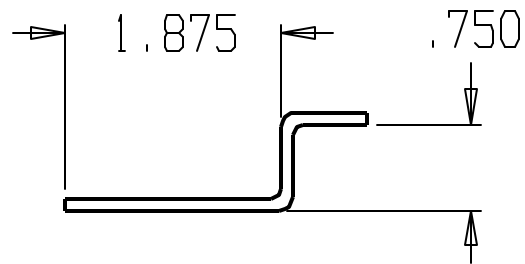
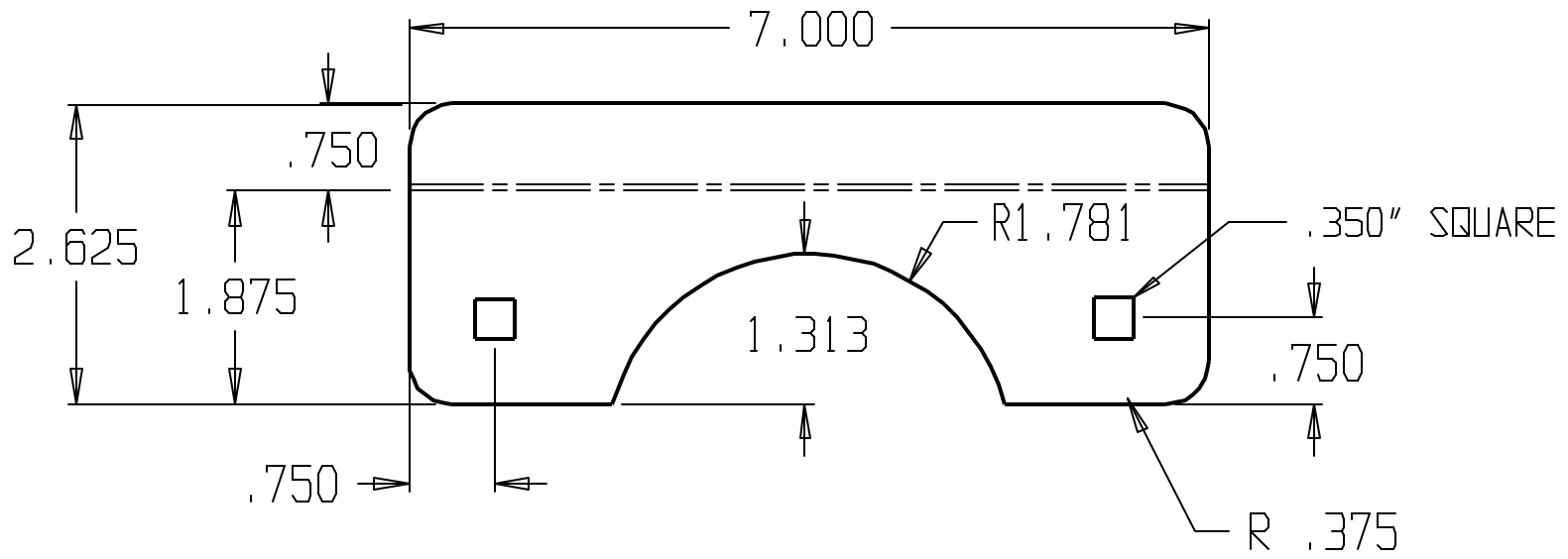

| | | | | | |
|------------------|--|-------|--------------|----------|-------|
| DON-JO MFG. INC. | | SIZE | DATE: | PART NO. | REV |
| DESIGNER | | A | 5/28/04 | OSLP-207 | |
| APPROVED | | SCALE | RELEASE DATE | WEIGHT | SHEET |

| REVISIONS | | |
|-----------|-----|----------------------|
| ZONE | REV | FINISHES: |
| | | BP, CP, DU, SL & 630 |
| | | GALUGE: |
| | | 12ga. .104 |

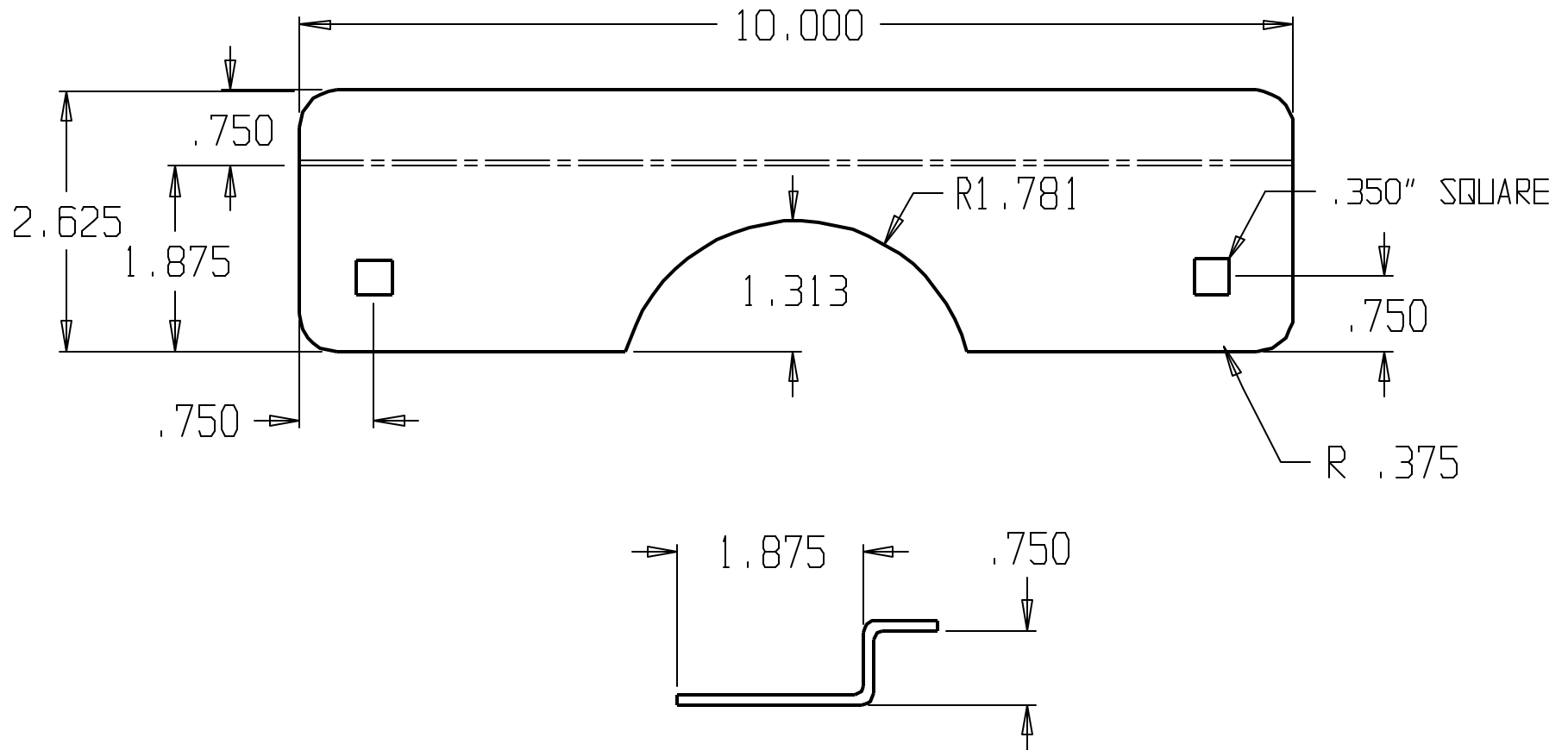

DON-JO MFG. INC.

| | | | | |
|----------|-------|--------------|----------|-------|
| DESIGNER | SIZE | DATE: | PART NO. | REV |
| | A | 5/28/04 | OSLP-210 | |
| APPROVED | SCALE | RELEASE DATE | WEIGHT | SHEET |
| | | | | |

| REVISIONS | | |
|-----------|-----|----------------------|
| ZONE | REV | FINISHES: |
| | | BP, CP, DU, SL & 630 |
| | | GALVE: |
| | | 12ga. .104 |

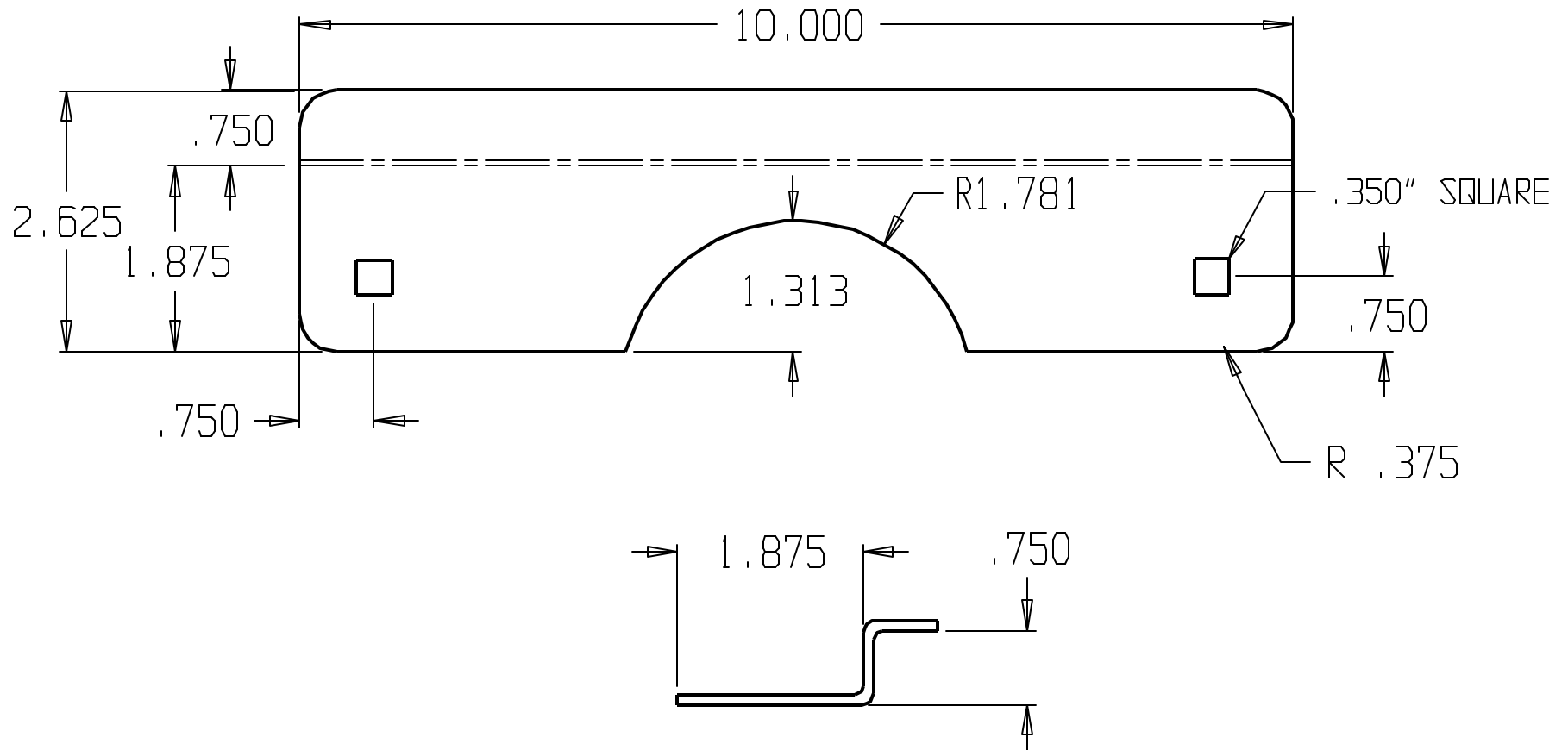

DON-JO MFG. INC.

| | | | | |
|----------|-----------|------------------|----------------------|-------|
| DESIGNER | SIZE A | DATE: 5/28/04 | PART NO. OSLP-210 | REV |
| APPROVED | SCALE | RELEASE DATE | WEIGHT | SHEET |

| REVISIONS | | | |
|-----------|-----|-----------|------------|
| ZONE | REV | FINISHES: | GAUGE: |
| | | 630 | 12ga. .104 |

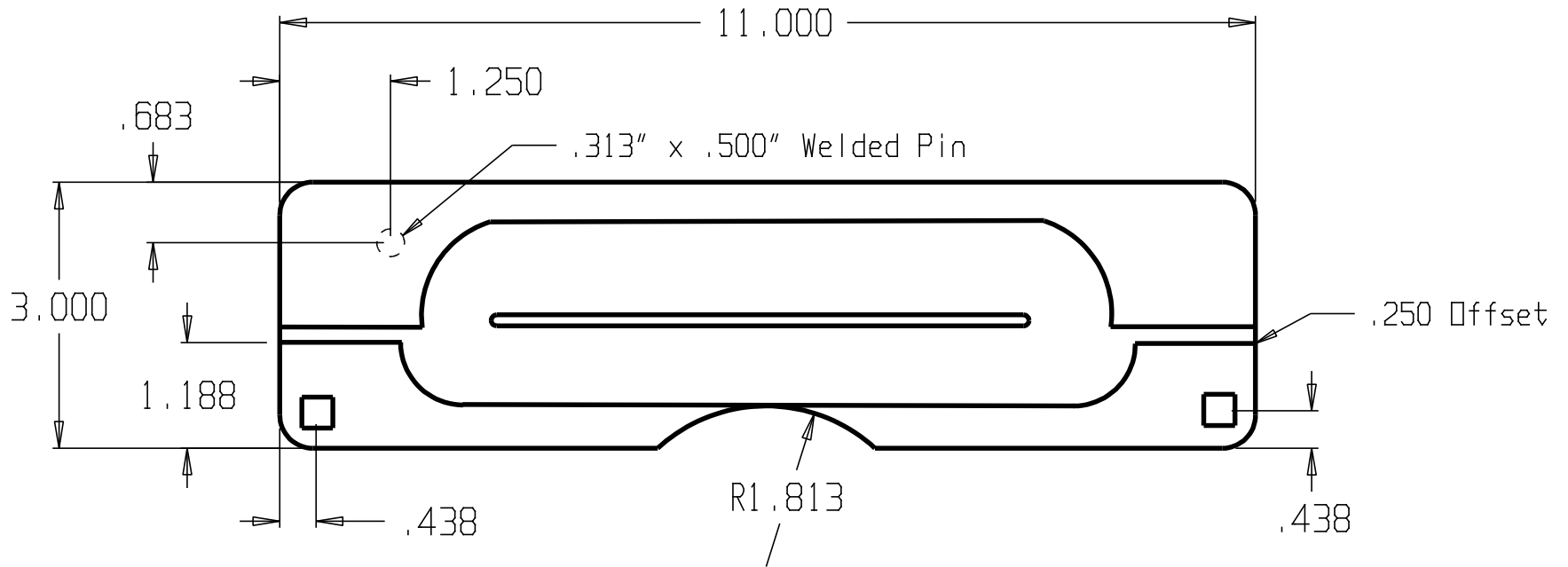

DON-JO MFG. INC.

| | | | | |
|----------|-------|--------------|----------|-------|
| DESIGNER | SIZE | DATE: | PART NO. | REV |
| | A | 5/28/04 | PLP-111 | |
| APPROVED | SCALE | RELEASE DATE | WEIGHT | SHEET |
| | | | | |

| REVISIONS | | | |
|-----------|-----|-----------|------------|
| ZONE | REV | FINISHES: | GAUGE: |
| | | 630 | 12ga. .104 |

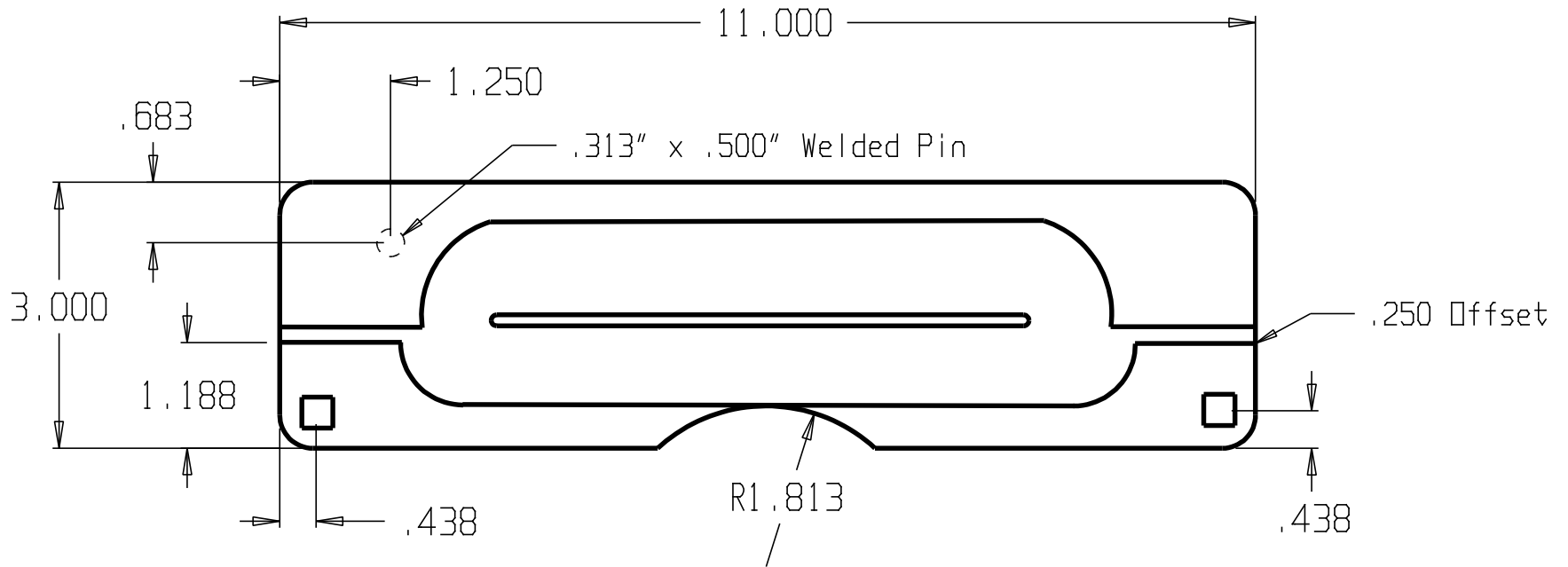

| | | | | | | | |
|------------------|--|-------|--------------|---------|-------|----------|-----|
| DON-JO MFG. INC. | | | | SIZE | DATE: | PART NO. | REV |
| DESIGNER | | A | 5/28/04 | PLP-111 | | | |
| APPROVED | | SCALE | RELEASE DATE | WEIGHT | SHEET | | |

| REVISIONS | | |
|-----------|-----|------------------|
| ZONE | REV | FINISHES: |
| | | 626, BP, DU & SL |
| | | GAUGE: |
| | | 12ga. .104 |

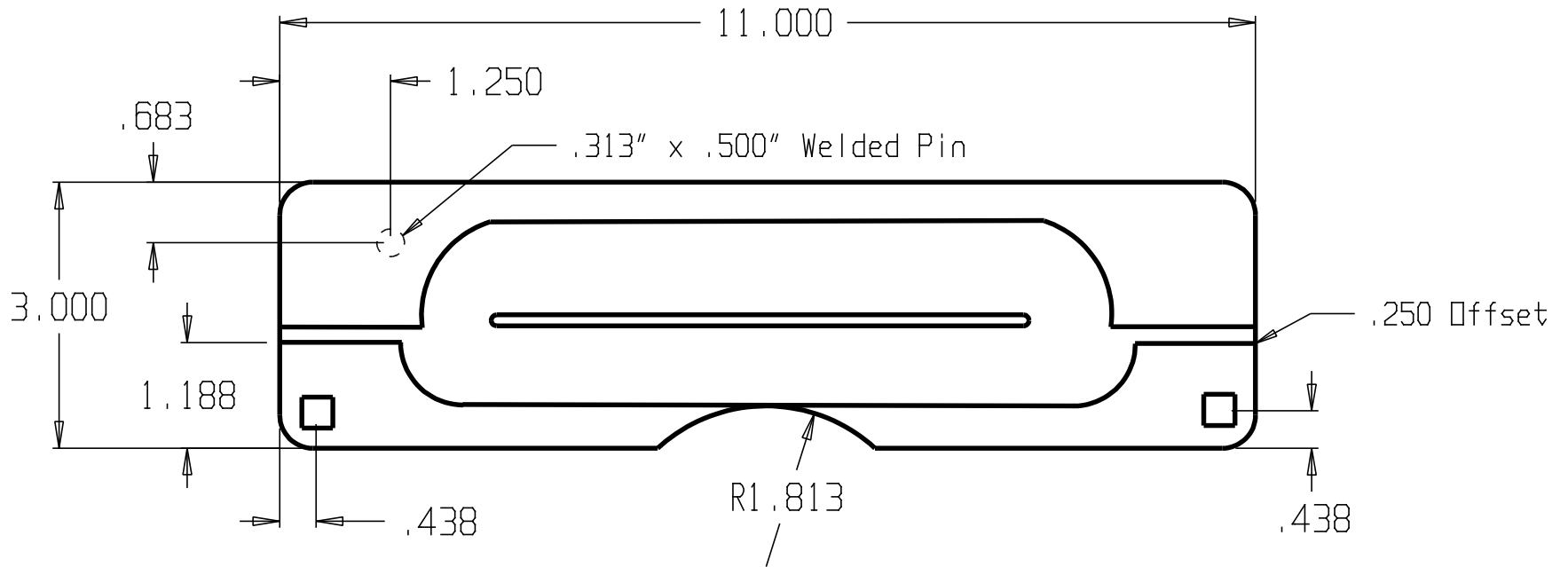

DON-JO MFG. INC.

| | | | | |
|----------|-------|--------------|----------|-------|
| DESIGNER | SIZE | DATE: | PART NO. | REV |
| | A | 5/28/04 | PLP-211 | |
| APPROVED | SCALE | RELEASE DATE | WEIGHT | SHEET |
| | | | | |

| REVISIONS | | |
|-----------|-----|------------------|
| ZONE | REV | FINISHES: |
| | | 626, BP, DU & SL |
| | | GAUGE: |
| | | 12ga. .104 |

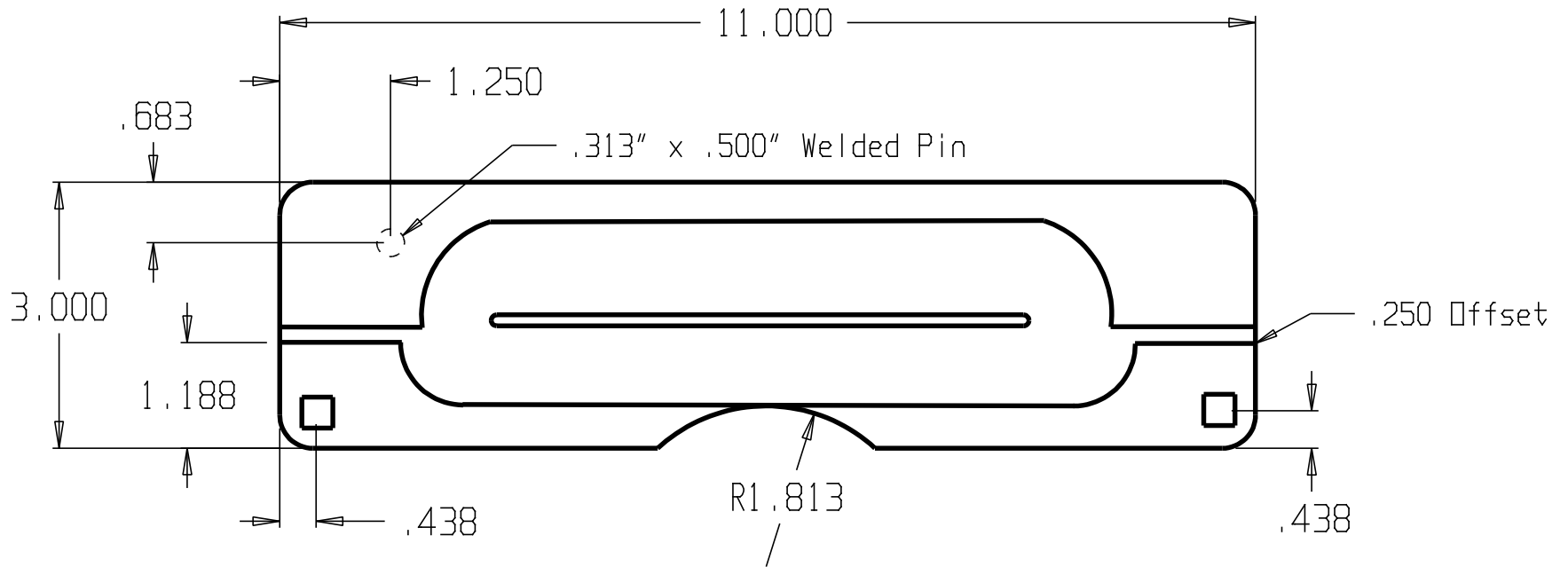

DON-JO MFG. INC.

| | | | | |
|----------|-------|--------------|----------|-------|
| DESIGNER | SIZE | DATE: | PART NO. | REV |
| | A | 5/28/04 | PLP-211 | |
| APPROVED | SCALE | RELEASE DATE | WEIGHT | SHEET |
| | | | | |

| REVISIONS | | | |
|-----------|-----|-----------|------------|
| ZONE | REV | FINISHES: | GAUGE: |
| | | 630 | 12ga. .104 |

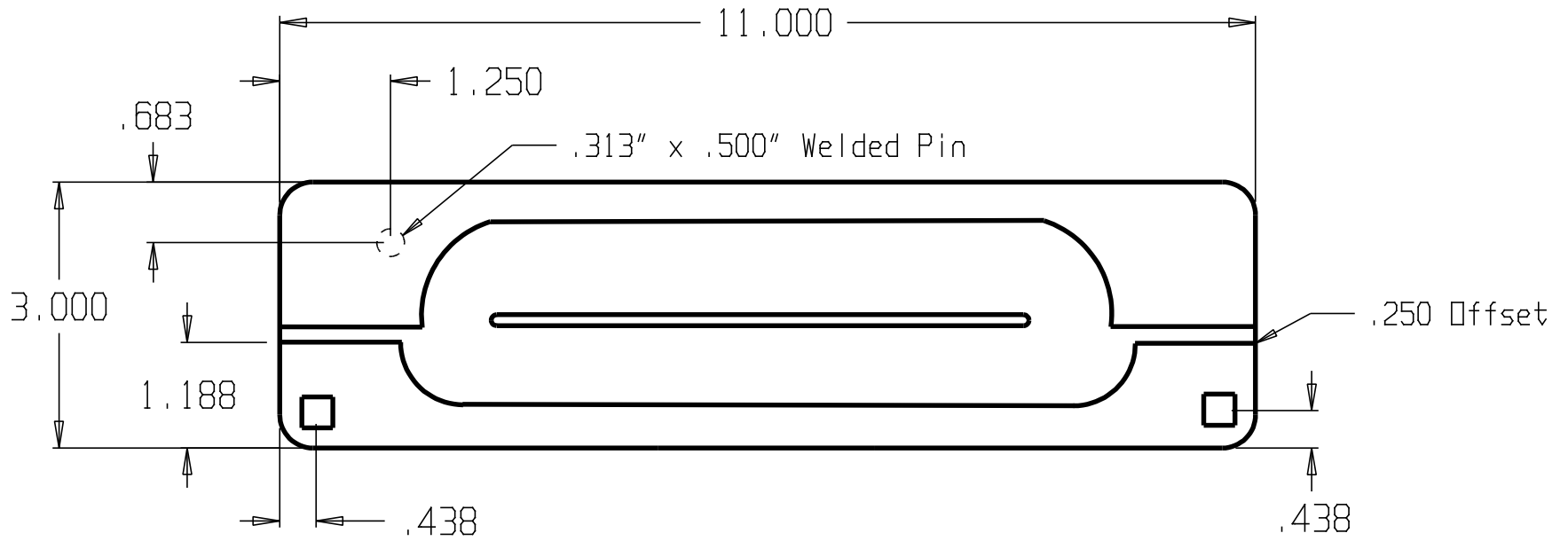

| | | | | | | | |
|------------------|--|-------|--------------|----------|-------|----------|-----|
| DON-JO MFG. INC. | | | | SIZE | DATE: | PART NO. | REV |
| DESIGNER | | A | 5/28/04 | PMLP-111 | | | |
| APPROVED | | SCALE | RELEASE DATE | WEIGHT | SHEET | | |

| REVISIONS | | | |
|-----------|-----|-----------|------------|
| ZONE | REV | FINISHES: | GAUGE: |
| | | 630 | 12ga. .104 |

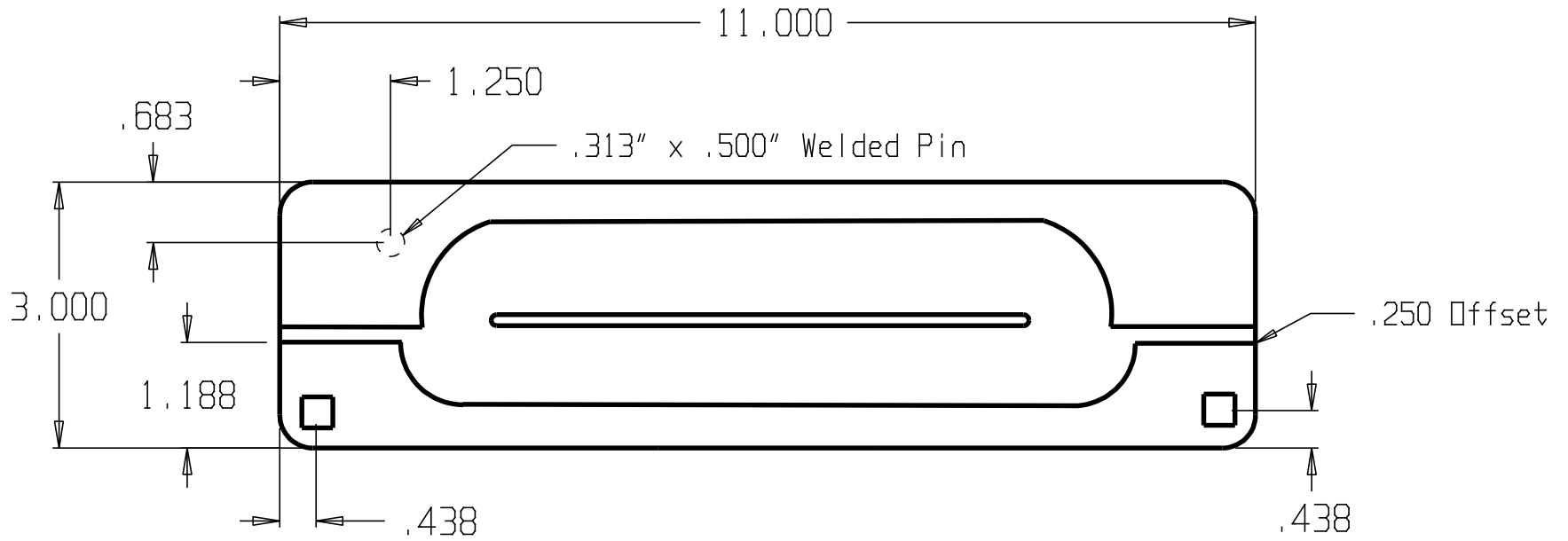

DON-JO MFG. INC.

| | | | | | |
|----------|--------------|--------|---------|----------|-----|
| DESIGNER | SCALE | SIZE | DATE: | PART NO. | REV |
| | | A | 5/28/04 | PMLP-111 | |
| APPROVED | RELEASE DATE | WEIGHT | SHEET | | |
| | | | | | |

| REVISIONS | | |
|-----------|-----|------------------|
| ZONE | REV | FINISHES: |
| | | 626, BP, DU & SL |
| | | GAUGE: |
| | | 12ga. .104 |

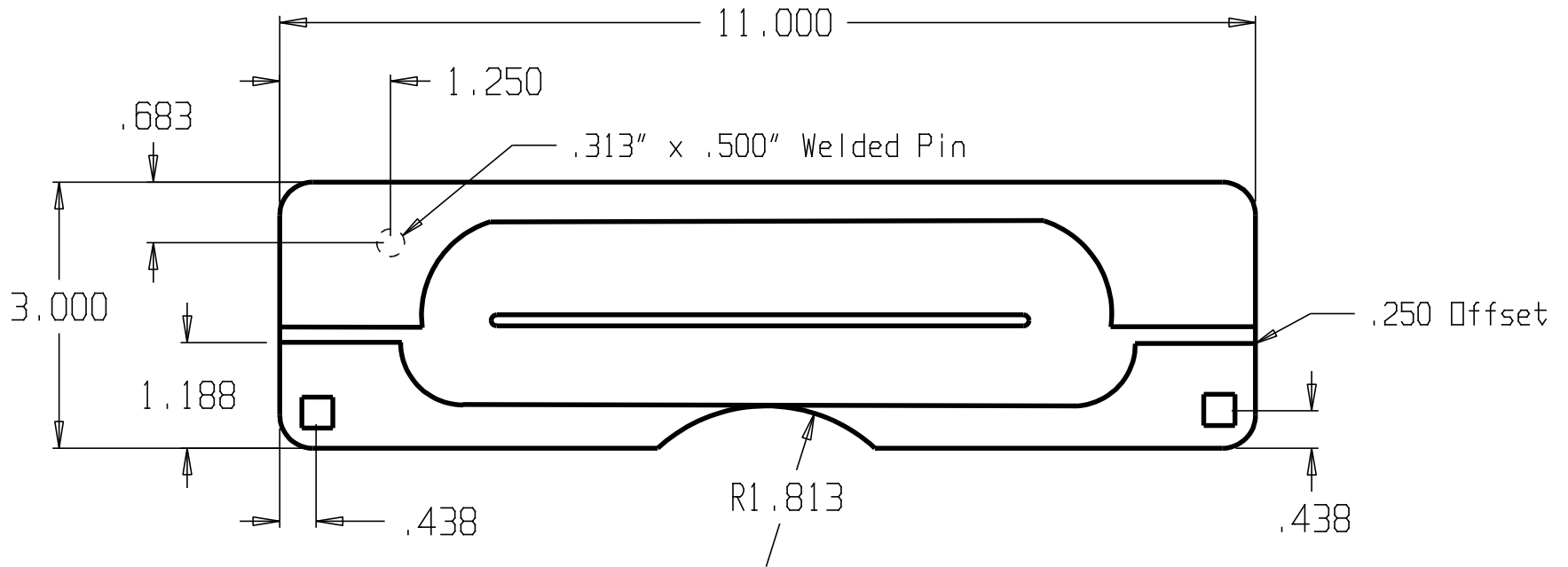

DON-JO MFG. INC.

| | | | | |
|----------|-------|--------------|----------|-------|
| DESIGNER | SIZE | DATE: | PART NO. | REV |
| | A | 5/28/04 | PLP-211 | |
| APPROVED | SCALE | RELEASE DATE | WEIGHT | SHEET |
| | | | | |

| REVISIONS | | |
|-----------|-----|------------------|
| ZONE | REV | FINISHES: |
| | | 626, BP, DU & SL |
| | | GAUGE: |
| | | 12ga. .104 |

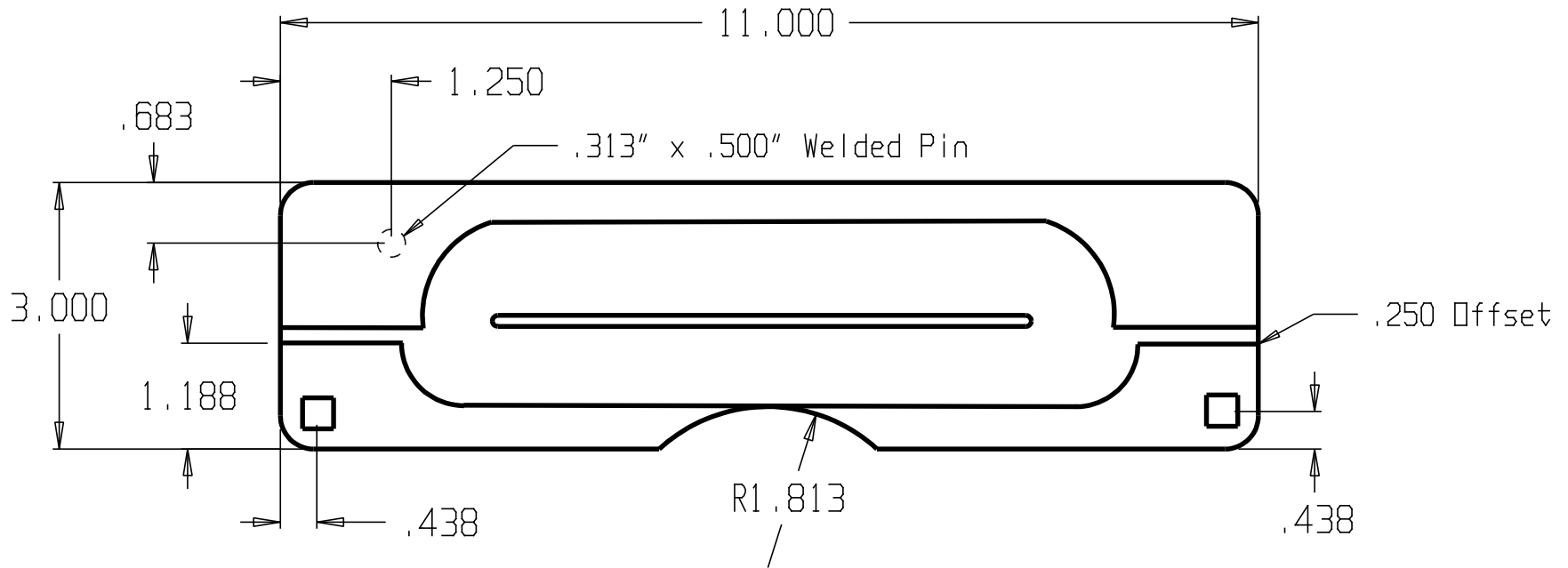

DON-JO MFG. INC.

| | | | | |
|----------|-------|--------------|----------|-------|
| DESIGNER | SIZE | DATE: | PART NO. | REV |
| | A | 5/28/04 | PLP-211 | |
| APPROVED | SCALE | RELEASE DATE | WEIGHT | SHEET |
| | | | | |

| REVISIONS | | | |
|-----------|-----|------------|------------|
| ZONE | REV | FINISHES : | GUAGE: |
| | | 630 | 12ga. .104 |

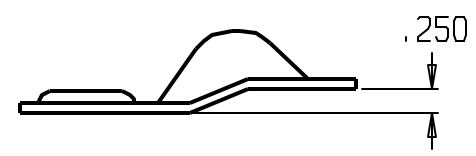
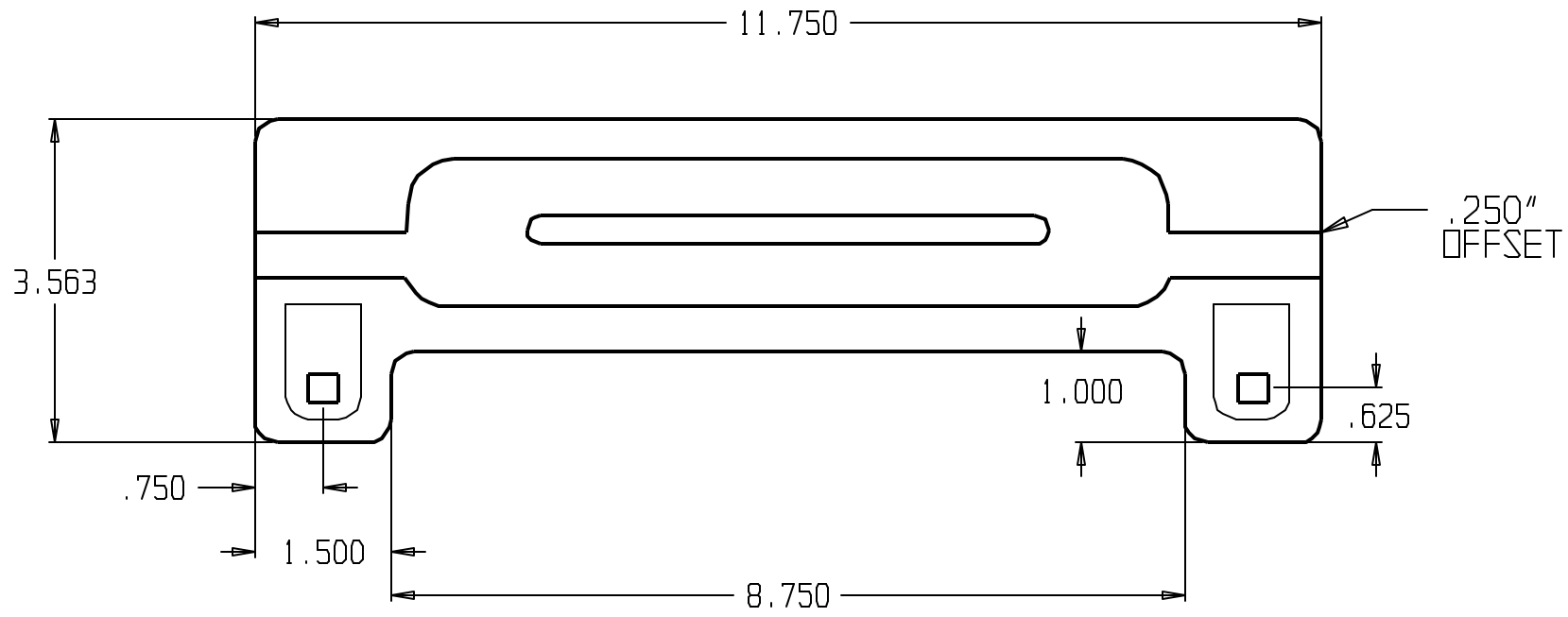

| | | | | | |
|------------------|------|-------|--------------|----------|-------|
| DON-JO MFG. INC. | | SIZE | DATE | PART NO. | REV |
| DESIGNER | D.R. | A | 2/13/09 | ULP-111 | |
| | | SCALE | RELEASE DATE | WEIGHT | SHEET |

| REVISIONS | | |
|-----------|-----|------------------|
| ZONE | REV | FINISHES: |
| | | 626, BP, DU & SL |
| | | Gauge: |
| | | 12ga. .104 |

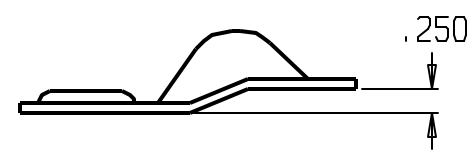
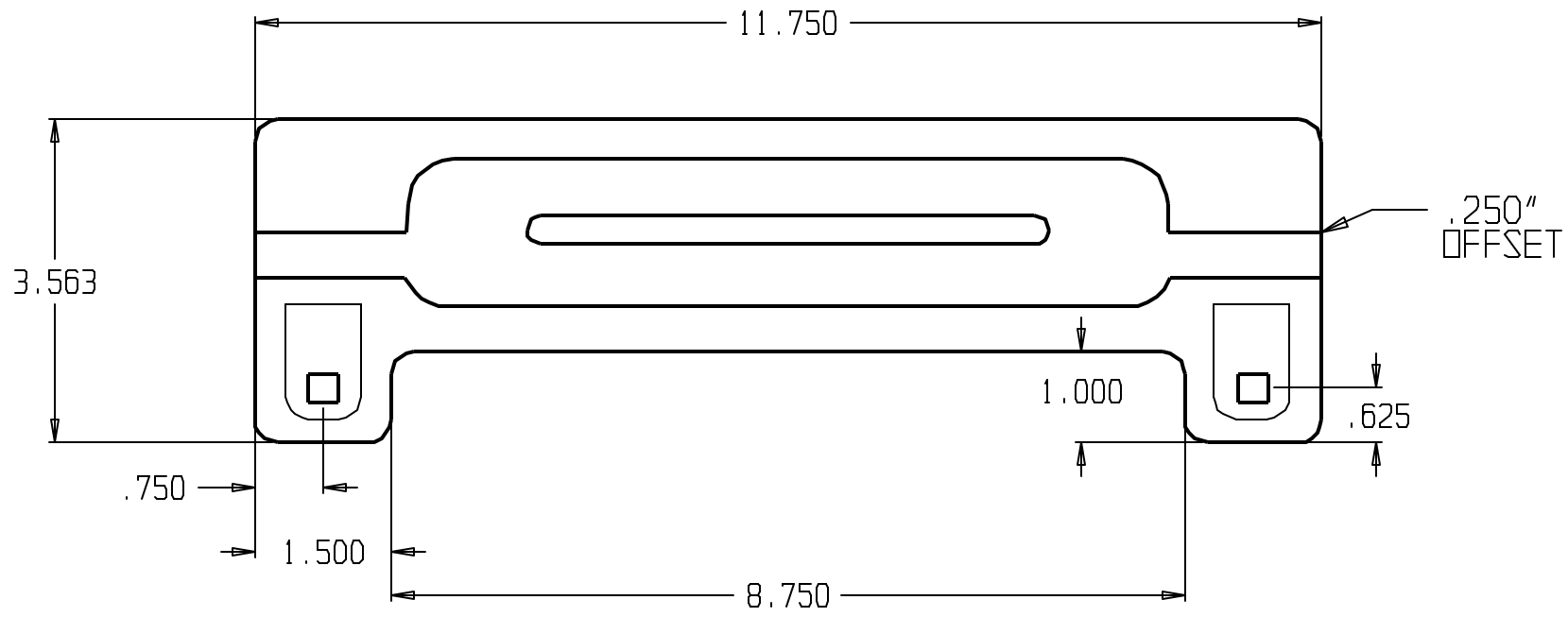

| | | | | | | | |
|------------------|------|-------|--------------|---------|-------|----------|-----|
| DON-JO MFG. INC. | | | | SIZE | DATE | PART NO. | REV |
| DESIGNER | D.R. | A | 2/13/09 | ULP-211 | | | |
| | | SCALE | RELEASE DATE | WEIGHT | SHEET | | |

| REVISIONS | | | |
|-----------|-----|-------------|------------|
| ZONE | REV | FINISHES: | GAUGE: |
| | | BP, DU & SL | 12ga. .104 |

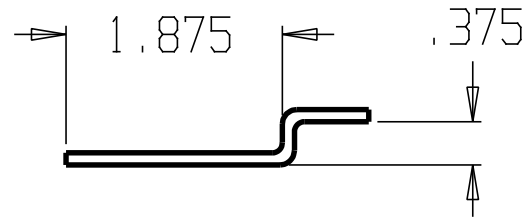
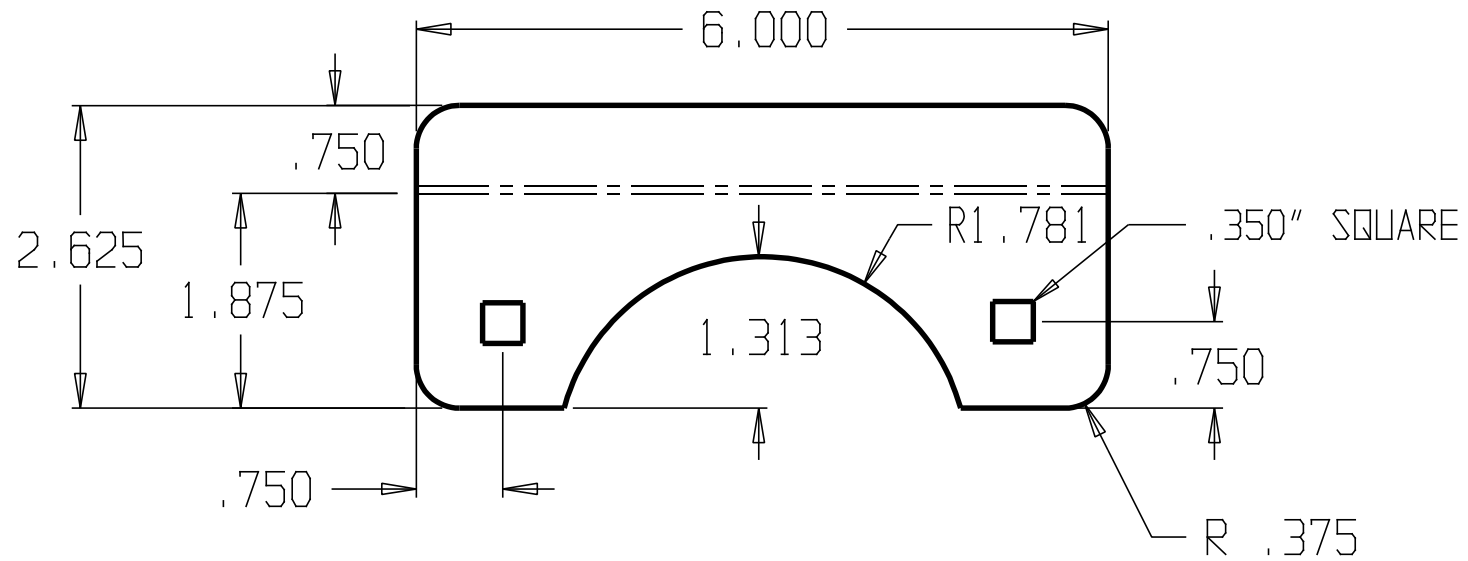

| | | | | | | | |
|------------------|--|-------|--------------|---------|-------|----------|-----|
| DON-JO MFG. INC. | | | | SIZE | DATE: | PART NO. | REV |
| DESIGNER | | A | 5/28/04 | SLP-206 | | | |
| APPROVED | | SCALE | RELEASE DATE | WEIGHT | SHEET | | |

| REVISIONS | | | |
|-----------|-----|------------|------------|
| ZONE | REV | FINISHES : | GUAGE : |
| | | 630 | 12ga. .104 |

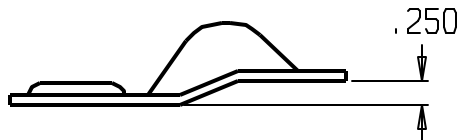
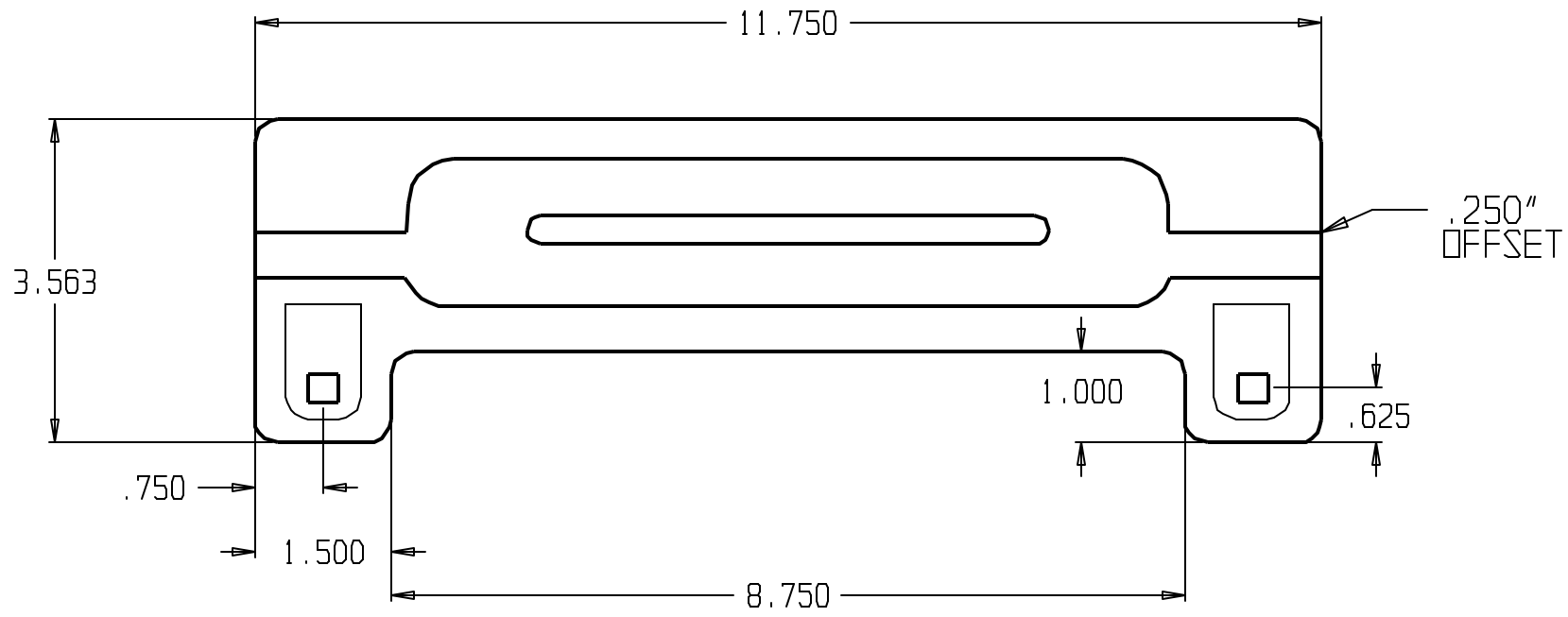

DON-JO MFG. INC.

| | | | |
|----------|--------------|----------|-------|
| DESIGNER | DATE | PART NO. | REV |
| D.R. | 2/13/09 | ULP-111 | |
| SCALE | RELEASE DATE | WEIGHT | SHEET |

| REVISIONS | | |
|-----------|-----|-------------------|
| ZONE | REV | FINISHES: |
| | | 626, BP, DU & SL |
| | | GUAGE: 12ga. .104 |

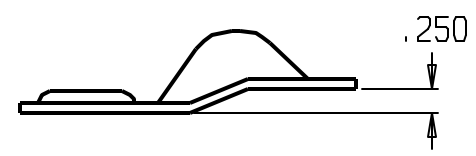
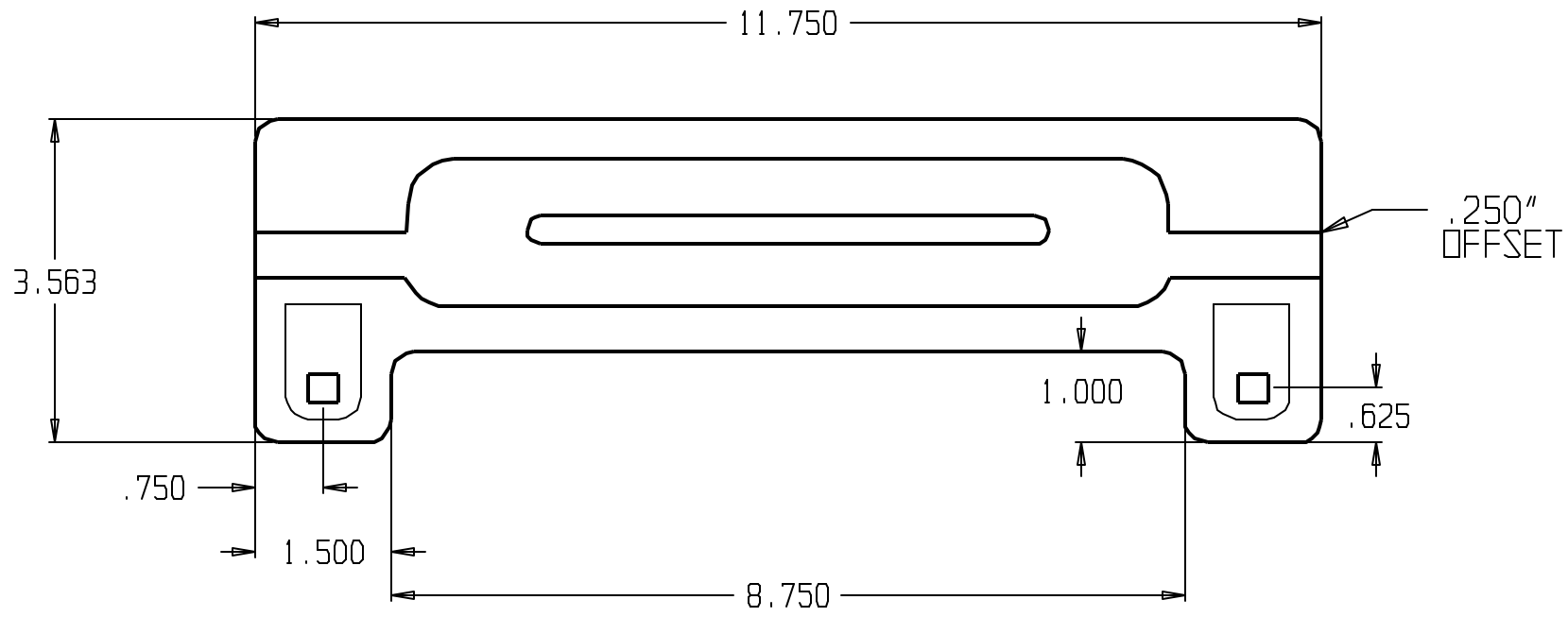

| | | | | | |
|------------------|------|-------|--------------|----------|-------|
| DON-JO MFG. INC. | | SIZE | DATE | PART NO. | REV |
| DESIGNER | D.R. | A | 2/13/09 | ULP-211 | |
| | | SCALE | RELEASE DATE | WEIGHT | SHEET |

REVISIONS

| ZONE | REV |
|------|-----|
| | |

FINISHES: 630, BP, DU, SL

GALIGE: 11ga. .135

GRAIN WITH THE 5.1875"

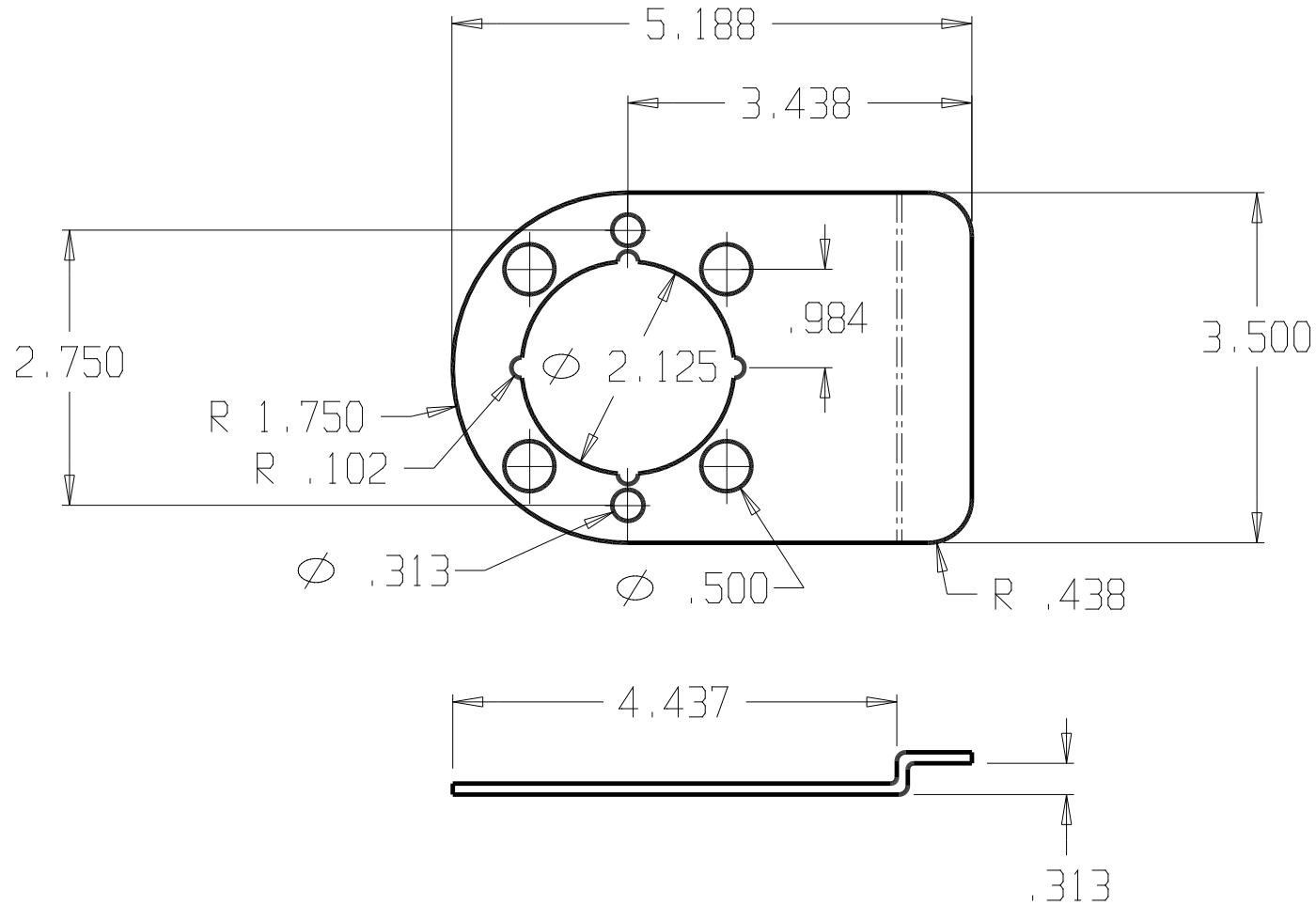

DON-JO MFG. INC.

DESIGNER

APPROVED

| | | | |
|-------|--------------|----------|-------|
| SIZE | DATE: | PART NO. | REV |
| A | 3/24/14 | WSLP-104 | |
| SCALE | RELEASE DATE | WEIGHT | SHEET |

DWG NO

SH

REV

REVISIONS

ZONE REV

FINISHES:

630, BP, DU, SL

GALIGE:

11ga. .135

GRAIN WITH THE 5.1875"

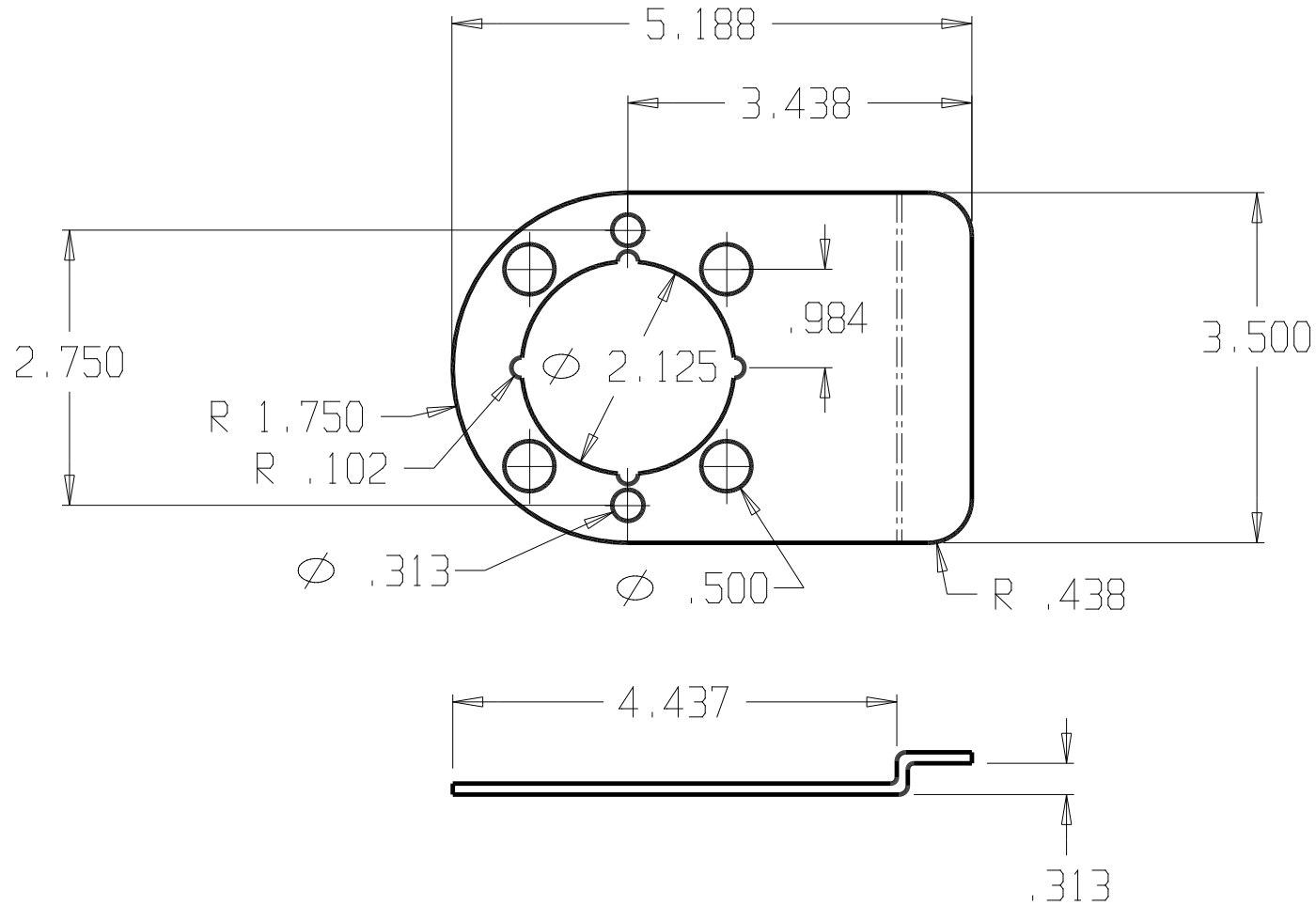

DON-JO MFG. INC.

DESIGNER

APPROVED

SIZE

A

DATE:

3/24/14

PART NO.

WSLP-104

REV

SCALE

RELEASE DATE

WEIGHT

SHEET

| | | |
|--------|----|-----|
| DWG NO | SH | REV |
|--------|----|-----|

| REVISIONS | | |
|-----------|-----|----------------|
| ZONE | REV | FINISHES : 626 |
| | | GALUGE : |

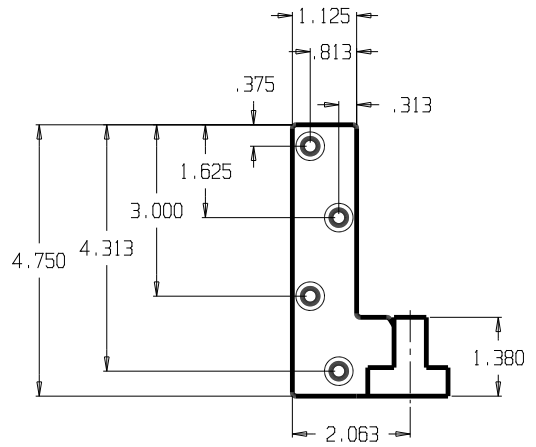
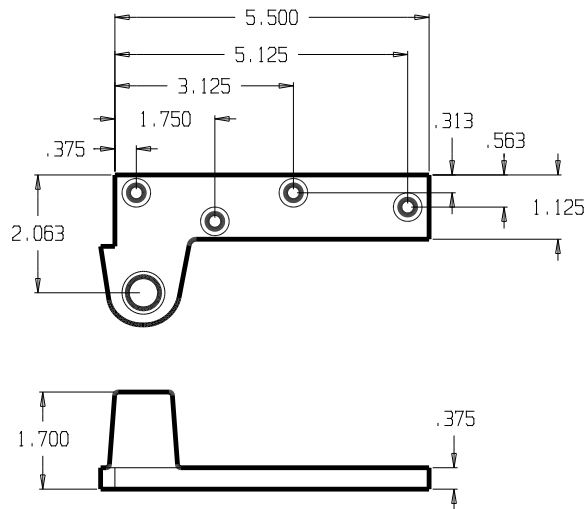

| | |
|------------------|------|
| DON-JO MFG. INC. | |
| DESIGNER | D.R. |

| | | | |
|-------|--------------|-------------|-------|
| SIZE | DATE: | PART NO. | REV |
| A | 8/4/15 | BP-1-23-LHR | |
| SCALE | RELEASE DATE | WEIGHT | SHEET |

| | | |
|---------|----|-----|
| DWG NO. | SH | REV |
|---------|----|-----|

| REVISIONS | | | |
|-----------|-----|------------|----------|
| ZONE | REV | FINISHES : | GALUGE : |
| | | 626 | |

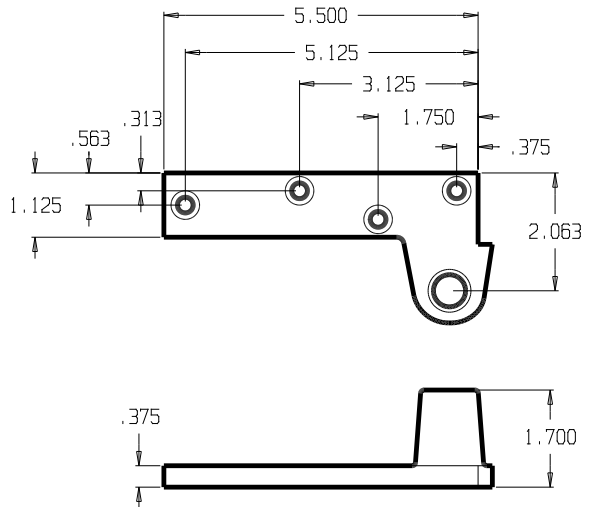
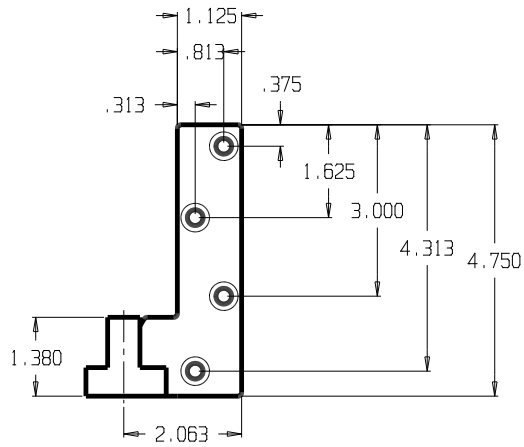

DON-JO MFG. INC.

| | |
|----------|------|
| DESIGNER | D.R. |
|----------|------|

| | | | |
|-------|--------------|-------------|-------|
| SIZE | DATE: | PART NO. | REV |
| A | 8/4/15 | BP-1-23-RHR | |
| SCALE | RELEASE DATE | WEIGHT | SHEET |

| | | |
|--------|----|-----|
| DWG NO | SH | REV |
|--------|----|-----|

| REVISIONS | | |
|-----------|-----|------------|
| ZONE | REV | FINISHES : |
| | | 626 |
| | | GALUGE : |

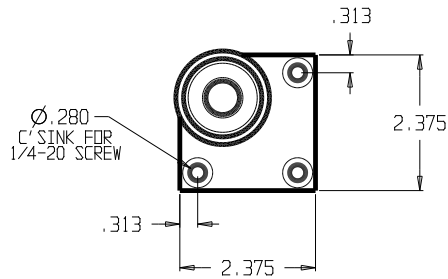
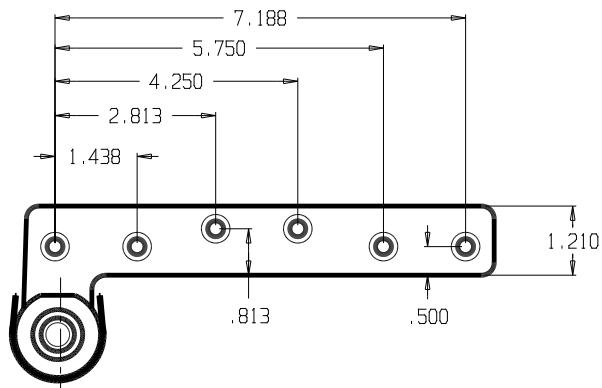

| | | | | | | | |
|-------------------------|------|-------|--------------|---------|---------|----------|-----|
| DON-JO MFG. INC. | | | | SIZE | DATE: | PART NO. | REV |
| DESIGNER | D.R. | A | | 8/12/15 | BP-2-34 | | |
| | | SCALE | RELEASE DATE | WEIGHT | SHEET | | |

| REVISIONS | | | |
|-----------|-----|------------|----------|
| ZONE | REV | FINISHES : | GALUGE : |
| | | | |

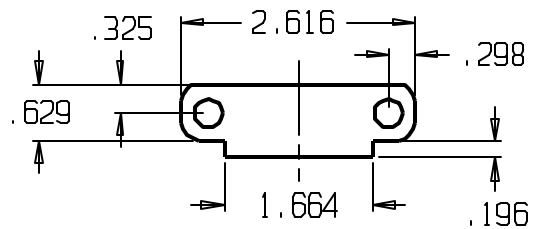
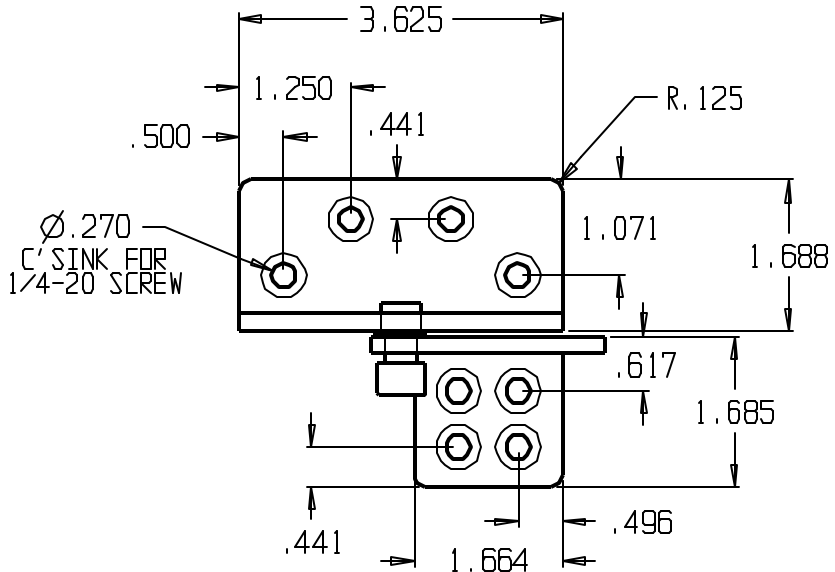
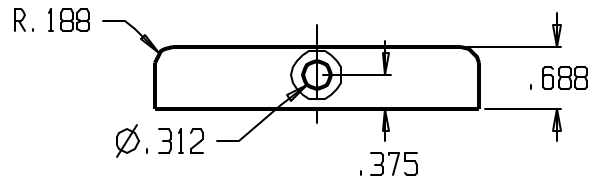
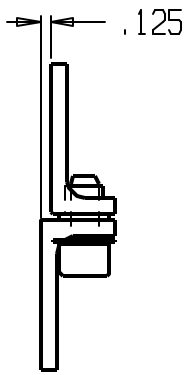
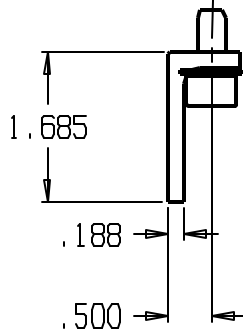
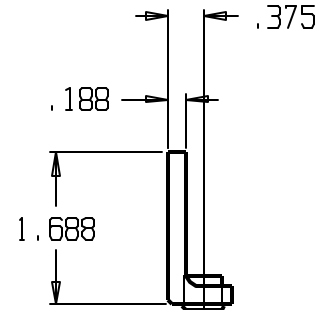

DON-JO MFG. INC.

| | | | | |
|------------------|-----------|----------------|-------------------|-------|
| DESIGNER D.R. | SIZE A | DATE 4/7/10 | PART NO. HRP-2 | REV |
| | SCALE | RELEASE DATE | WEIGHT | SHEET |

| | | |
|---------|----|-----|
| DWG NO. | SH | REV |
|---------|----|-----|

| REVISIONS | | |
|-----------|-----|---------------|
| ZONE | REV | FINISHES : |
| | | 605, 613, 626 |
| | | GALUGE : |

JAMB LEAF DOOR LEAF

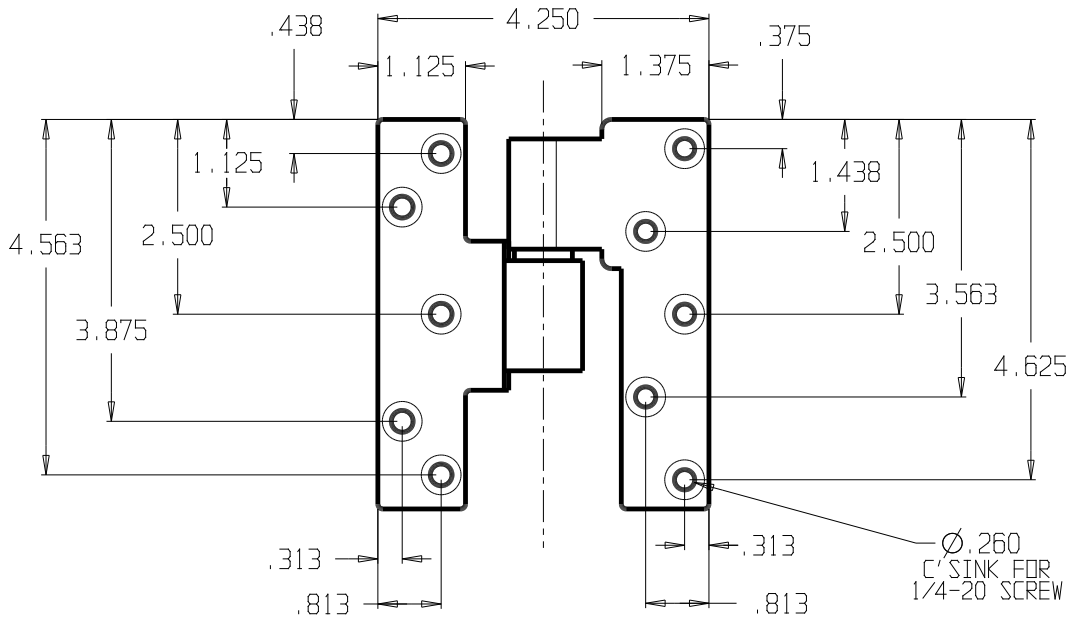

| | | | | | | | |
|-------------------------|------|--------------|--|---------|-----------|----------|-----|
| DON-JO MFG. INC. | | | | SIZE | DATE: | PART NO. | REV |
| DESIGNER | D.R. | A | | 3/20/14 | IP-34-LHR | | |
| SCALE | | RELEASE DATE | | WEIGHT | | SHEET | |

| | | |
|---------|----|-----|
| DWG NO. | SH | REV |
|---------|----|-----|

| REVISIONS | | |
|-----------|-----|---------------|
| ZONE | REV | FINISHES : |
| | | 605, 613, 626 |
| | | GALUGE : |

JAMB LEAF DOOR LEAF

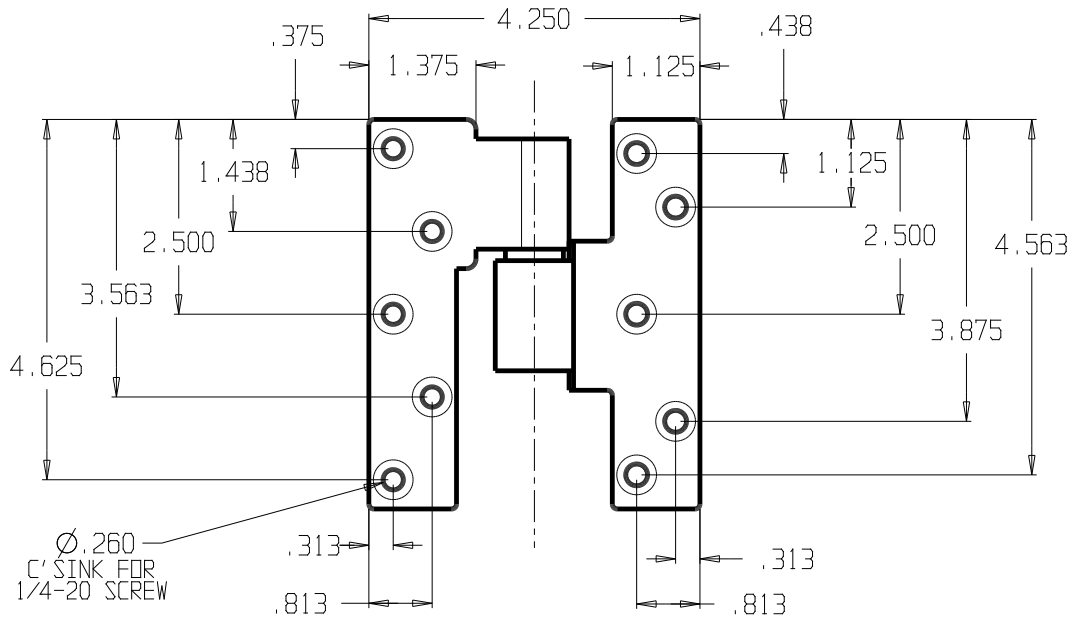

| | | | | | | | |
|------------------|------|--------------|--|---------|-----------|----------|-----|
| DON-JO MFG. INC. | | | | SIZE | DATE: | PART NO. | REV |
| DESIGNER | D.R. | A | | 3/20/14 | IP-34-RHR | | |
| SCALE | | RELEASE DATE | | WEIGHT | | SHEET | |

| | | |
|---------|----|-----|
| DWG NO. | SH | REV |
|---------|----|-----|

| REVISIONS | | |
|-----------|-----|---------------|
| ZONE | REV | FINISHES : |
| | | 626 |
| | | GALUGE : 1/4" |

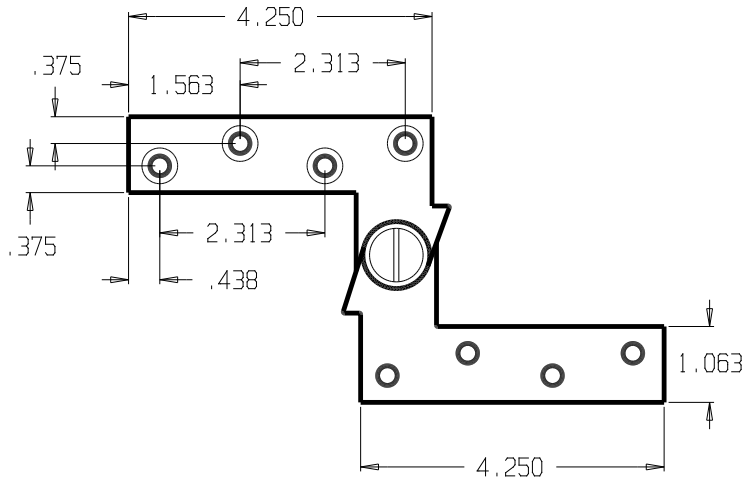

| | |
|------------------|------|
| DON-JO MFG. INC. | |
| DESIGNER | D.R. |

| | | | |
|-------|--------------|-----------|-------|
| SIZE | DATE: | PART NO. | REV |
| A | 8/6/15 | TP-34-626 | |
| SCALE | RELEASE DATE | WEIGHT | SHEET |

| REVISIONS | | | | |
|-----------|-----|---------------------|------|----------|
| ZONE | REV | Finishes: | DATE | APPROVED |
| | | 605-612-613-628-630 | | |

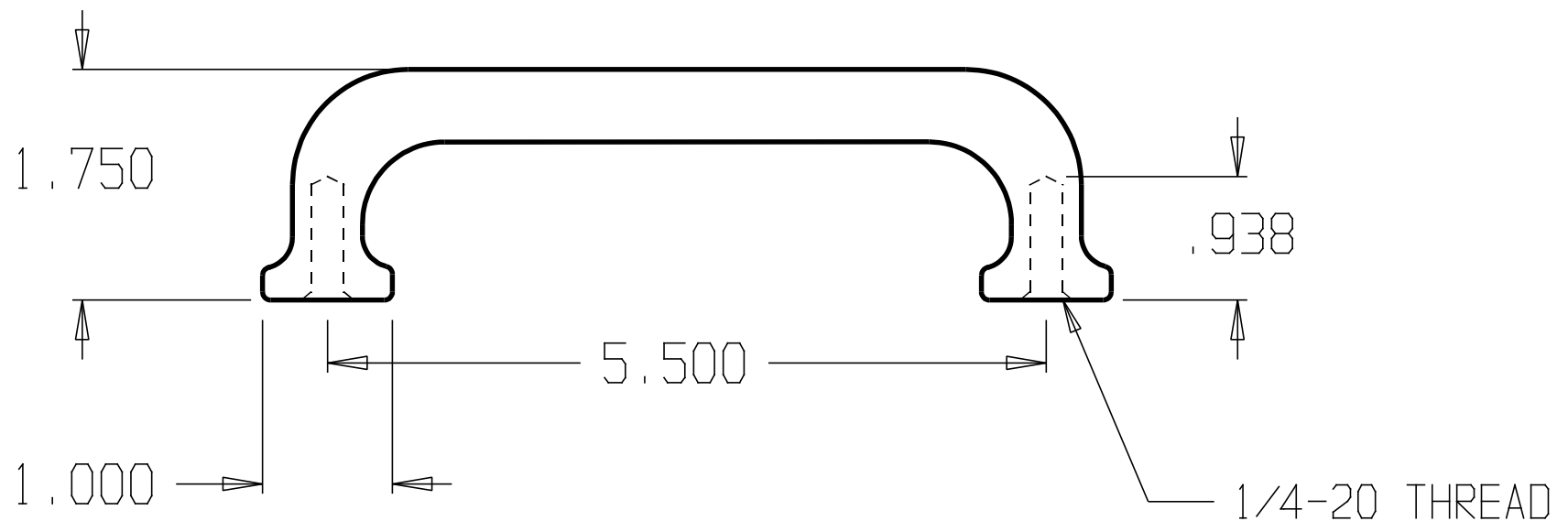

DON-JO MFG. INC.

| | |
|----------|--|
| DESIGNER | |
| APPROVED | |

| | | | |
|-----------|------------------|-----------------|-------|
| SIZE A | DATE: 2/10/04 | PART NO. #10 | REV |
| SCALE | RELEASE DATE | WEIGHT | SHEET |

| | | |
|--------|----|-----|
| DWG NO | SH | REV |
|--------|----|-----|

| REVISIONS | | | | |
|-----------|-----|-----------------------------|------|----------|
| ZONE | REV | FINISHES: | DATE | APPROVED |
| | | 605,606,612,613,628,629,630 | | |

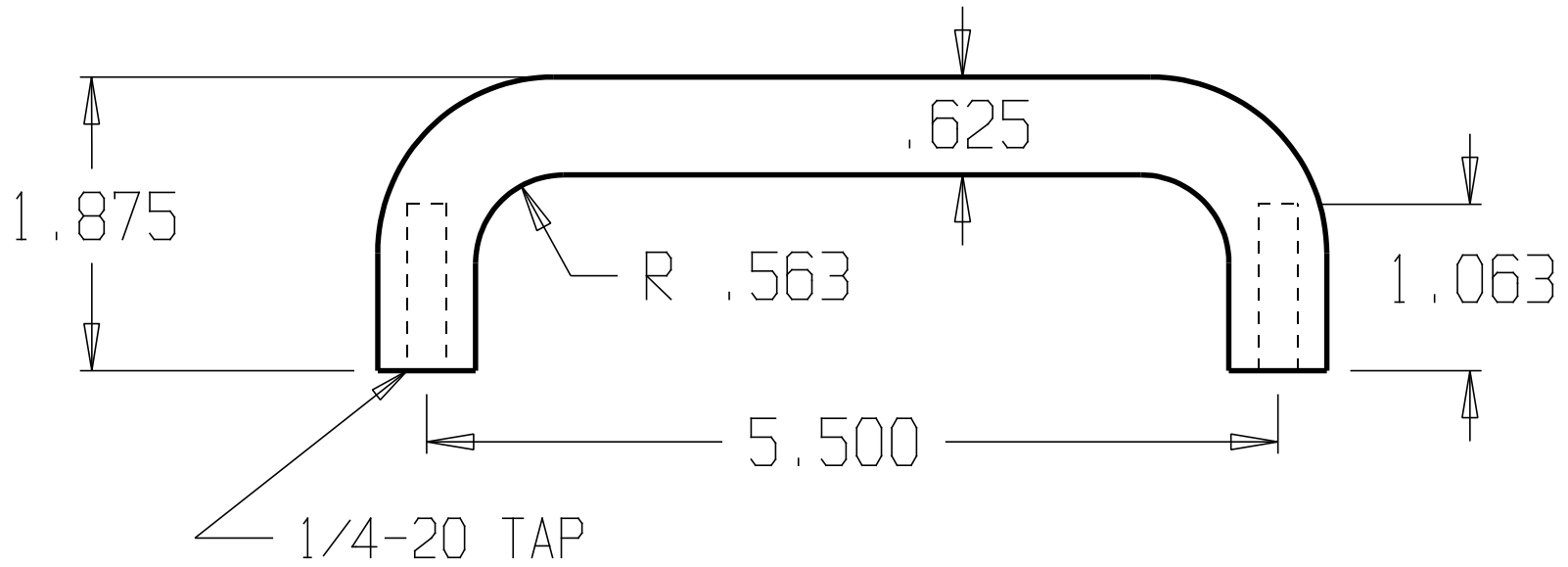

| | |
|------------------|--|
| DON-JO MFG. INC. | |
| DESIGNER | |
| APPROVED | |

| | | | |
|-----------|------------------|-----------------|-------|
| SIZE A | DATE: 2/10/04 | PART NO. #11 | REV |
| SCALE | RELEASE DATE | WEIGHT | SHEET |

| REVISIONS | | | |
|-----------|-----|------------------------------|------|
| ZONE | REV | FINISHES : | DATE |
| | | 605, 606, 613, 628, 629, 630 | |
| | | APPROVED | |

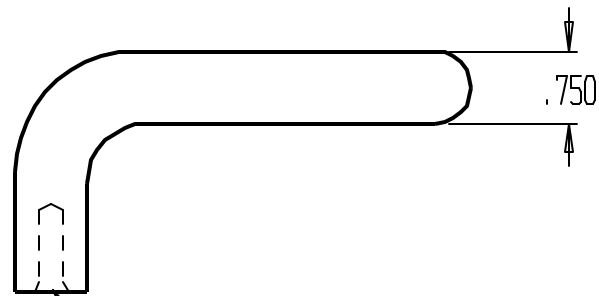
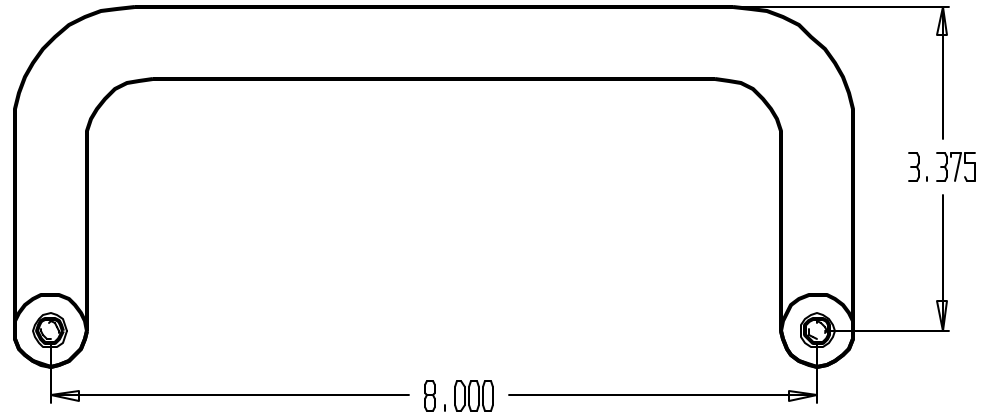

1/4-20 TAP
2 PLCS.

DON-JO MFG. INC.

| | | | | |
|----------|-----------|-----------------|-------------------|-------|
| DESIGNER | SIZE A | DATE 2/10/04 | PART NO. #1150 | REV |
| APPROVED | SCALE | RELEASE DATE | WEIGHT | SHEET |

| REVISIONS | | | |
|-----------|-----|------------------------------|------|
| ZONE | REV | FINISHES: | DATE |
| | | 605, 606, 613, 628, 629, 630 | |
| | | APPROVED | |

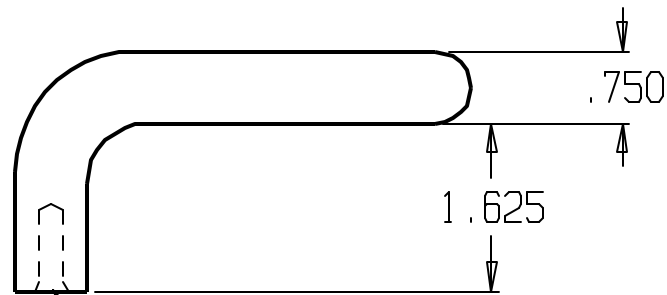
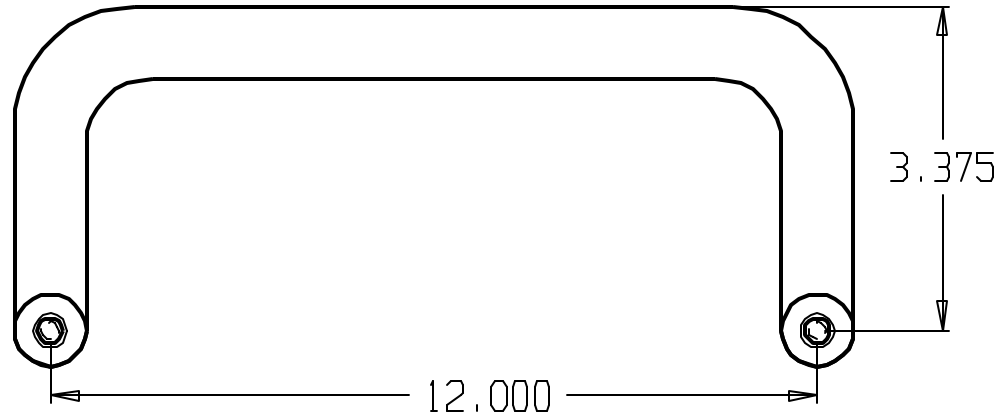

1/4-20 TAP
2 PLCS.

DON-JO MFG. INC.

| | | | | |
|----------|-----------|-----------------|-------------------|-------|
| DESIGNER | SIZE A | DATE 2/10/04 | PART NO. #1152 | REV |
| APPROVED | SCALE | RELEASE DATE | WEIGHT | SHEET |

| REVISIONS | | | |
|-----------|-----|------------------------------|------|
| ZONE | REV | FINISHES: | DATE |
| | | 605, 606, 613, 628, 629, 630 | |
| | | APPROVED | |

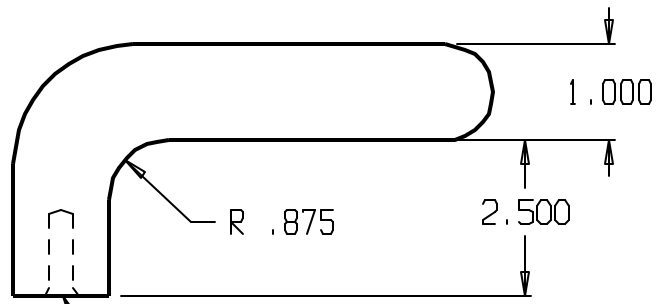
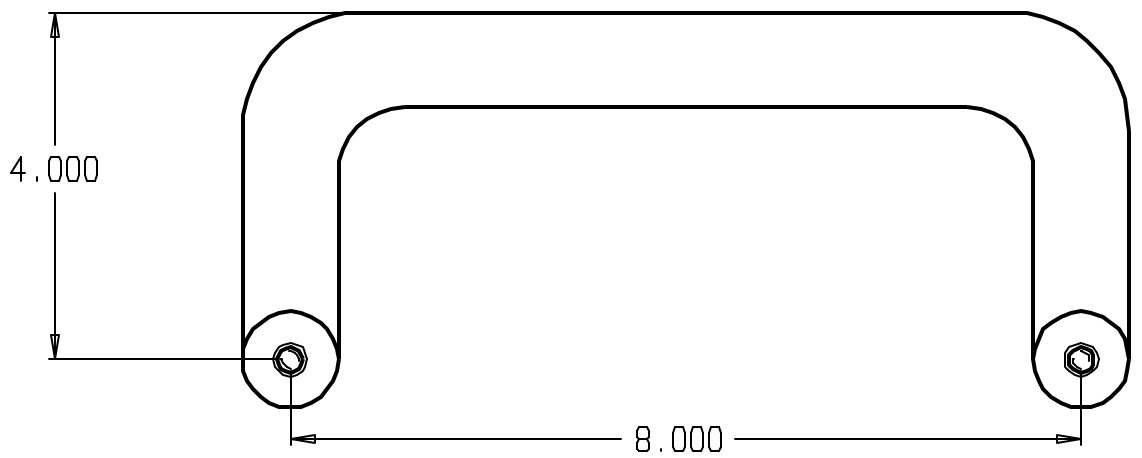

3/8-24 Tap
2 Plcs.

DON-JO MFG. INC.

| | | | | |
|----------|-------|--------------|----------|-------|
| DESIGNER | SIZE | DATE | PART NO. | REV |
| | A | 2/10/04 | #1156 | |
| APPROVED | SCALE | RELEASE DATE | WEIGHT | SHEET |

| REVISIONS | | | | |
|-----------|-----|------------------------------|------|----------|
| ZONE | REV | FINISHES: | DATE | APPROVED |
| | | 605, 606, 613, 628, 629, 630 | | |

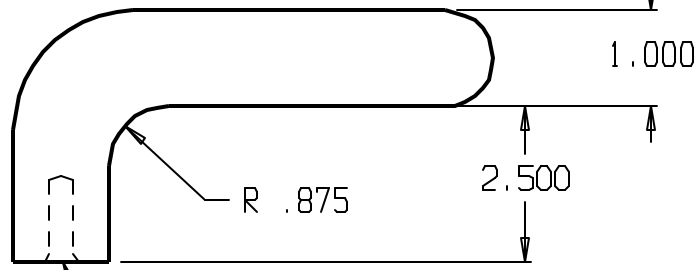
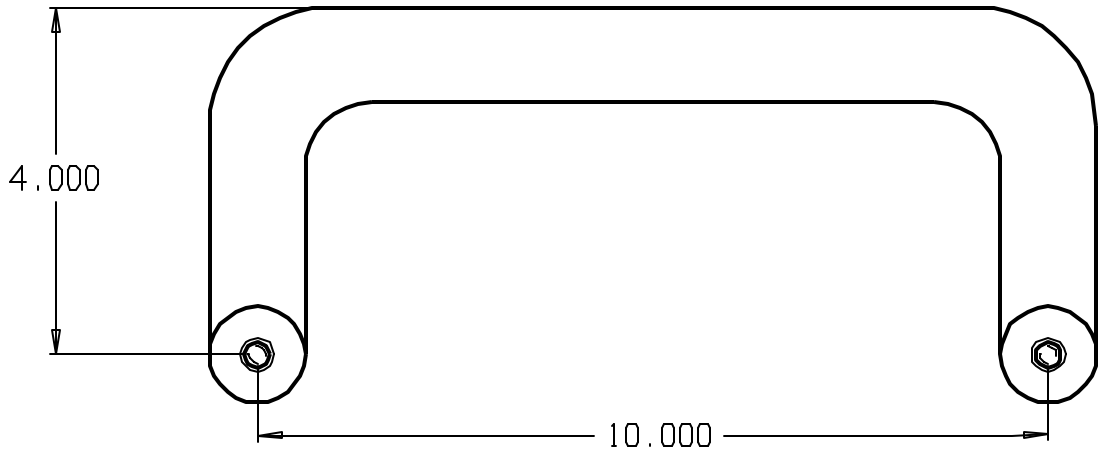

3/8-24 TAP
2 PLCS.

DON-JO MFG. INC.

| | | | | |
|----------|-----------|-----------------|-------------------|-------|
| DESIGNER | SIZE A | DATE 2/10/04 | PART NO. #1157 | REV |
| APPROVED | SCALE | RELEASE DATE | WEIGHT | SHEET |

| REVISIONS | | | | |
|-----------|-----|------------------------------|------|----------|
| ZONE | REV | FINISHES: | DATE | APPROVED |
| | | 605, 606, 613, 628, 629, 630 | | |

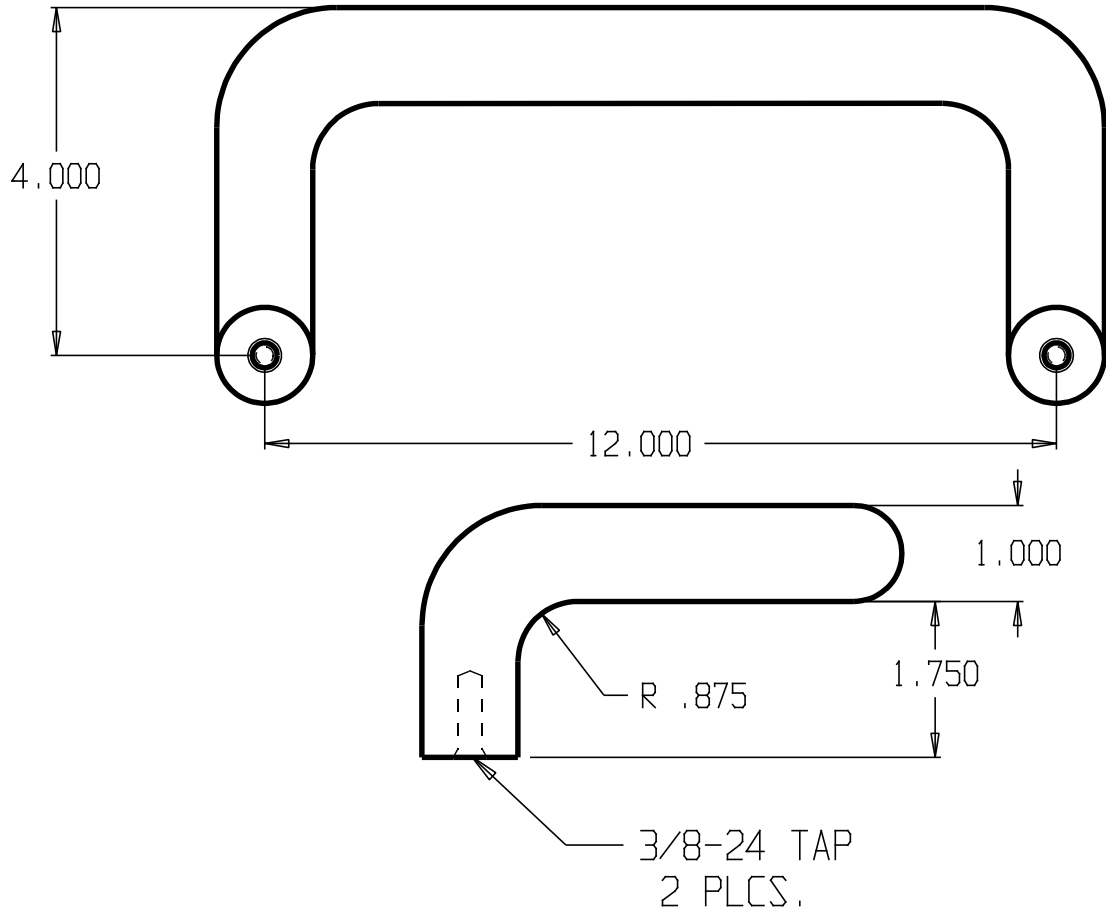

DON-JO MFG. INC.

| | | | | |
|----------|-----------|------------------|-------------------|-------|
| DESIGNER | SIZE A | DATE: 2/10/04 | PART NO. #1158 | REV |
| APPROVED | SCALE | RELEASE DATE | WEIGHT | SHEET |

| REVISIONS | | | | |
|-----------|-----|------------------------------|------|----------|
| ZONE | REV | FINISHES: | DATE | APPROVED |
| | | 605, 606, 613, 628, 629, 630 | | |

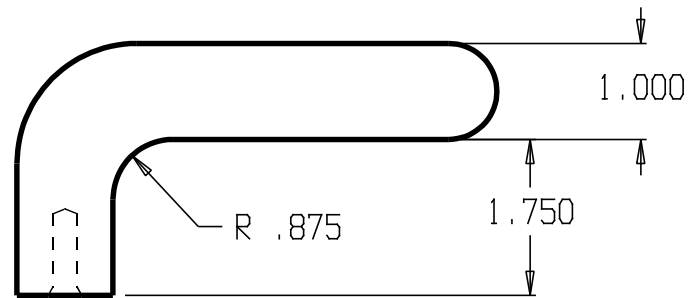
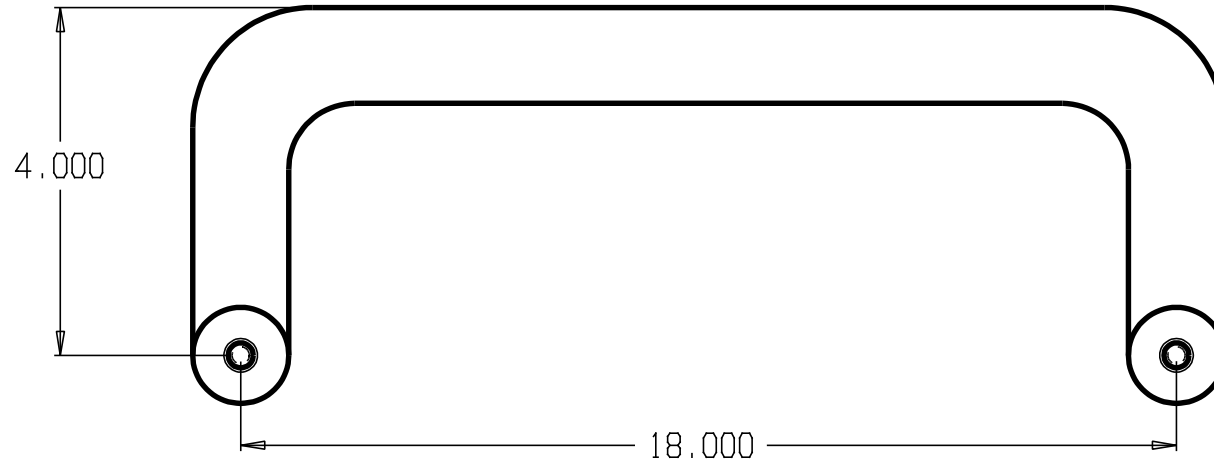

3/8-24 TAP
2 PLCS.

DON-JO MFG. INC.

| | | | | |
|----------|-------|--------------|----------|-------|
| DESIGNER | SIZE | DATE: | PART NO. | REV |
| | A | 2/10/04 | #1159 | |
| APPROVED | SCALE | RELEASE DATE | WEIGHT | SHEET |
| | | | | |

| REVISIONS | | | | |
|-----------|-----|------------------------------|------|----------|
| ZONE | REV | FINISHES : | DATE | APPROVED |
| | | 605, 606, 613, 628, 629, 630 | | |

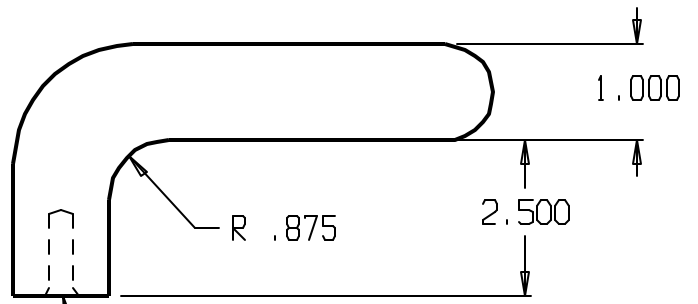
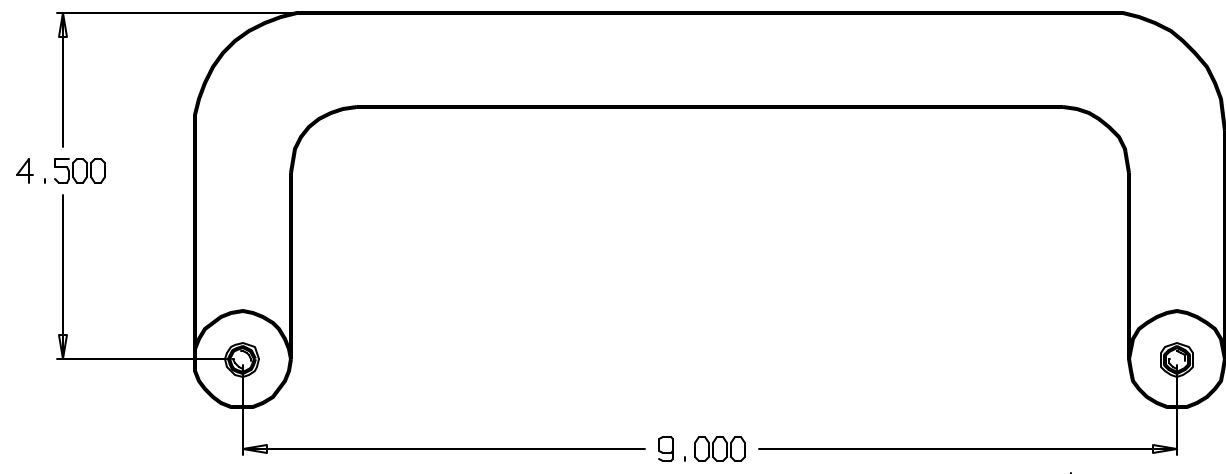

3/8-24 TAP
2 PLCS.

DON-JO MFG. INC.

| | | | | |
|----------|-----------|-----------------|-------------------|-------|
| DESIGNER | SIZE A | DATE 8/22/11 | PART NO. #1160 | REV |
| APPROVED | SCALE | RELEASE DATE | WEIGHT | SHEET |

| REVISIONS | | |
|-----------|-----|-------------------------|
| ZONE | REV | FINISHES: |
| | | 605, 613, 619, 620, 626 |
| | | GUAGE: |

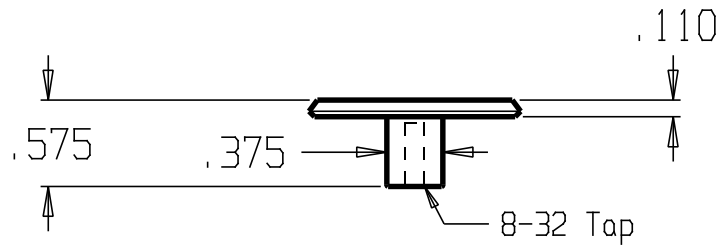
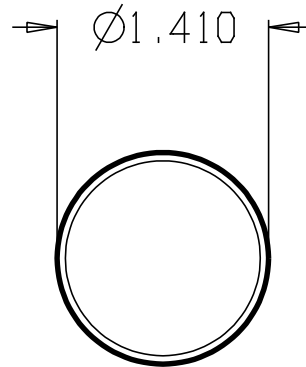

DON-JO MFG. INC.

| | | | | |
|----------|-------|--------------|----------|-------|
| DESIGNER | SIZE | DATE: | PART NO. | REV |
| | A | 12/15/04 | #120 | |
| APPROVED | SCALE | RELEASE DATE | WEIGHT | SHEET |

| REVISIONS | | |
|-----------|-----|-------------------------|
| ZONE | REV | FINISHES: |
| | | 605, 613, 619, 620, 626 |
| | | GUAGE: |

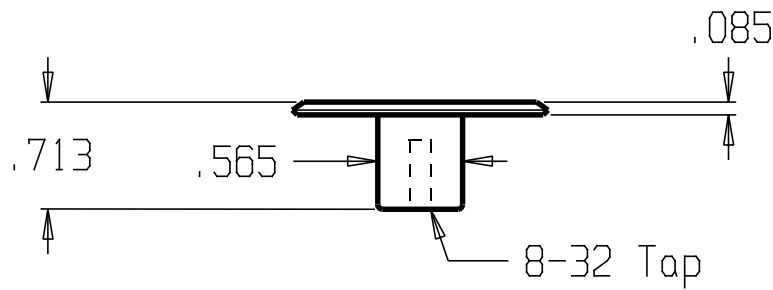
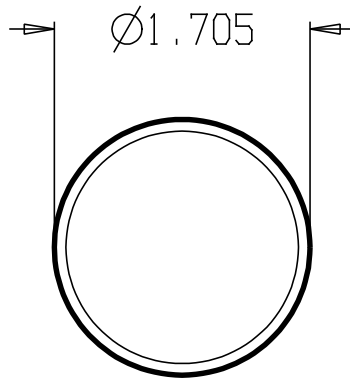

DON-JO MFG. INC.

| | | | | |
|----------|-------|--------------|----------|-------|
| DESIGNER | SIZE | DATE: | PART NO. | REV |
| | A | 12/15/04 | #121 | |
| APPROVED | SCALE | RELEASE DATE | WEIGHT | SHEET |

| REVISIONS | | | | |
|-----------|-----|-----------------------------------|------|----------|
| ZONE | REV | FINISHES: | DATE | APPROVED |
| | | 605, 606, 612, 613, 628, 629, 630 | | |

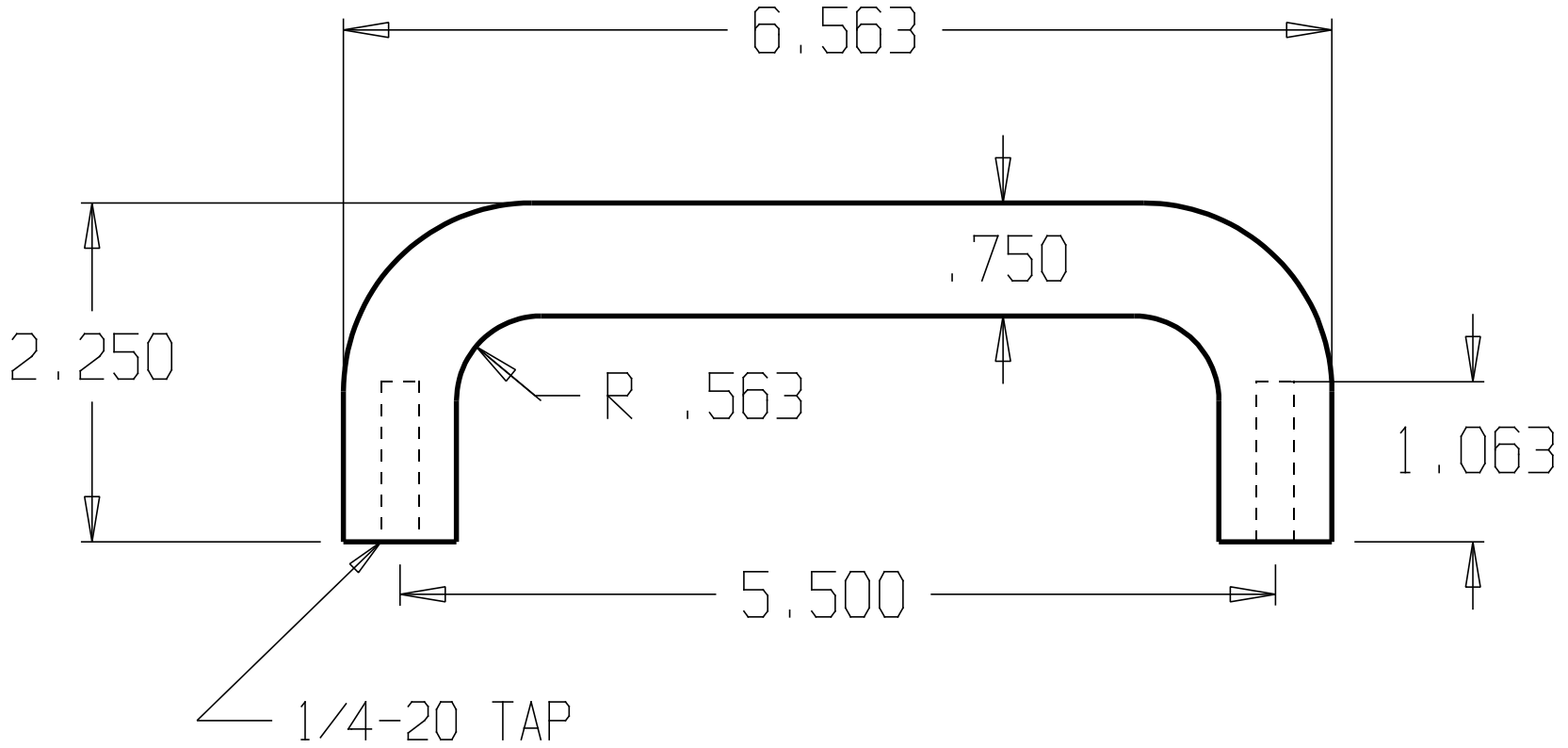

| | | | | |
|------------------|-----------|------------------|-----------------|-------|
| DON-JO MFG. INC. | | | | |
| DESIGNER | SIZE A | DATE: 2/10/04 | PART NO. #14 | REV |
| APPROVED | SCALE | RELEASE DATE | WEIGHT | SHEET |

| REVISIONS | | | | |
|-----------|-----|-----------------------------|------|----------|
| ZONE | REV | FINISHES: | DATE | APPROVED |
| | | 605,626,612,613,628,629,630 | | |

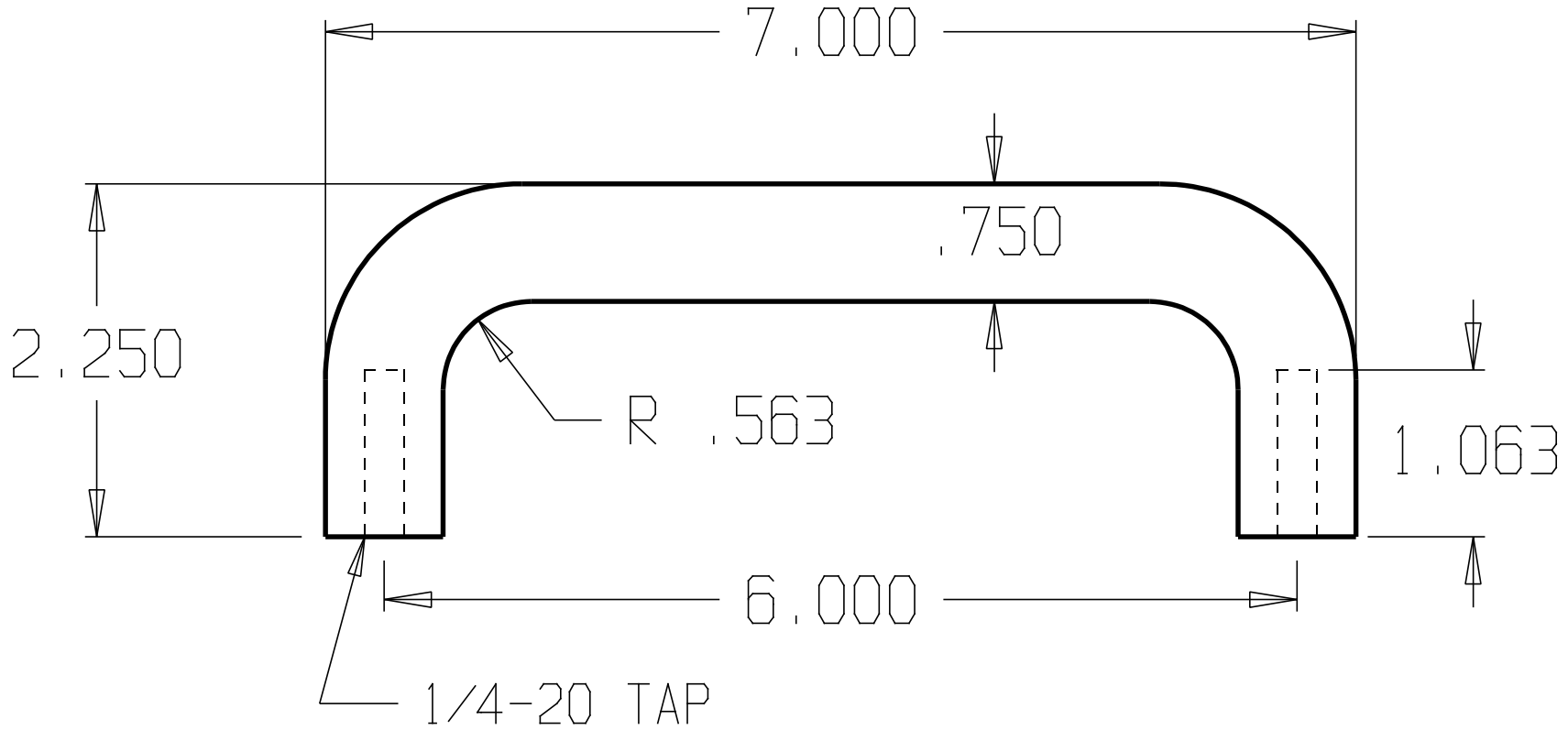

| | | | | |
|------------------|---------|---------------|--------------|-------|
| DON-JO MFG. INC. | | | | |
| DESIGNER | SIZE: A | DATE: 3/23/04 | PART NO. #15 | REV |
| APPROVED | SCALE | RELEASE DATE | WEIGHT | SHEET |

| REVISIONS | | | | |
|-----------|-----|-----------------------------------|------|----------|
| ZONE | REV | FINISHES : | DATE | APPROVED |
| | | 605, 606, 612, 613, 628, 629, 630 | | |

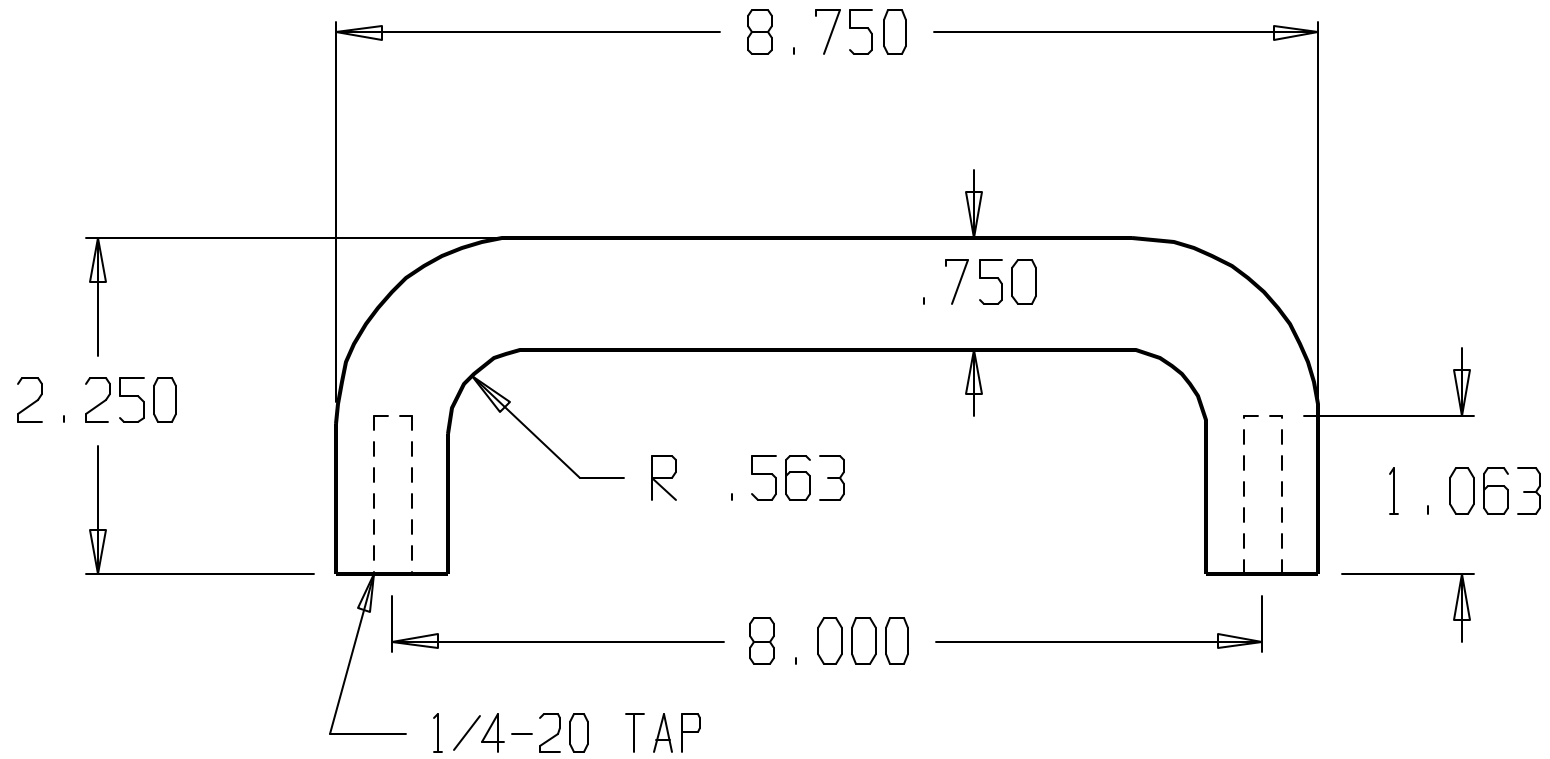

DON-JO MFG. INC.

| | |
|----------|--|
| DESIGNER | |
| APPROVED | |

| | | | |
|-----------|------------------|-----------------|-------|
| SIZE A | DATE: 3/25/04 | PART NO. #16 | REV |
| SCALE | RELEASE DATE | WEIGHT | SHEET |

| REVISIONS | | | | |
|-----------|-----|-----------------------------------|------|----------|
| ZONE | REV | FINISHES: | DATE | APPROVED |
| | | 605, 606, 612, 613, 628, 629, 630 | | |

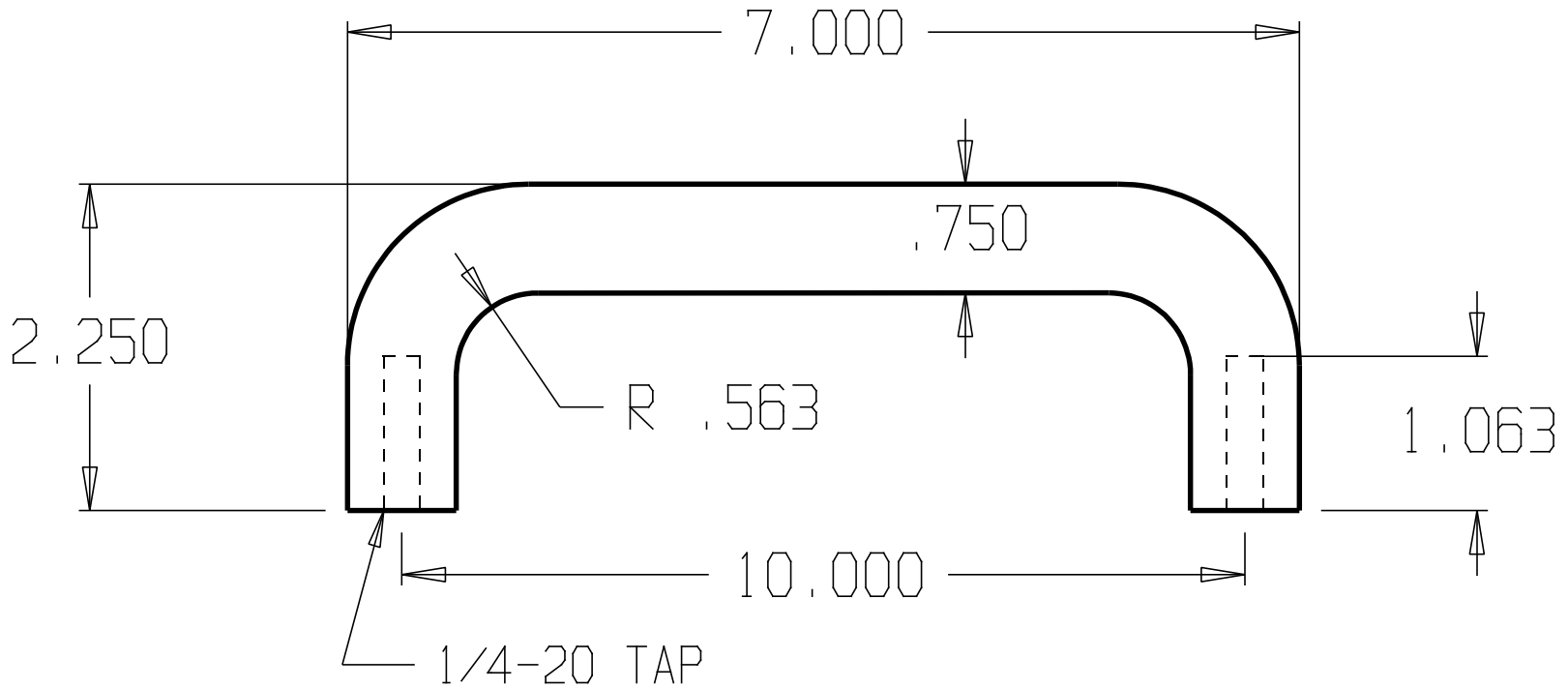

DON-JO MFG. INC.

DESIGNER
APPROVED

| | | | |
|-----------|------------------|-----------------|-------|
| SIZE A | DATE: 3/29/04 | PART NO. #17 | REV |
| SCALE | RELEASE DATE | WEIGHT | SHEET |

| REVISIONS | | |
|-----------|-----|-------------|
| ZONE | REV | FINISHES: |
| | | 630 |
| | | GAUGE: |
| | | 11ga. .125" |

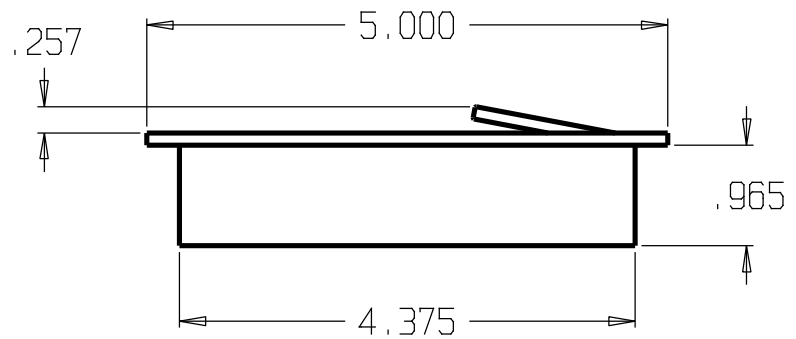
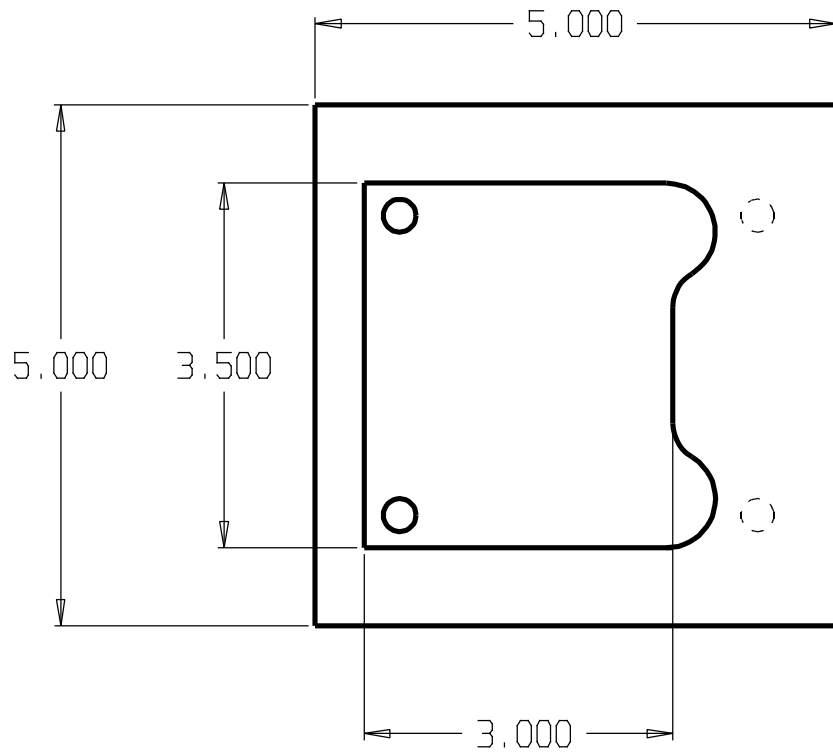

CUT OUT NEEDED
3.875" X 4.375"

DON-JO MFG. INC.

DESIGNER
D.R.

| | | | |
|-----------|-------------------|-------------------|-------|
| SIZE A | DATE: 11/11/10 | PART NO. #1846 | REV |
| SCALE | RELEASE DATE | WEIGHT | SHEET |

REVISIONS

| ZONE | REV | FINISHES: | DATE | APPROVED |
|------|-----|-----------|------|----------|
| | | 630 | | |

CUT OUT NEEDED
2 3/4" X 3 3/4"

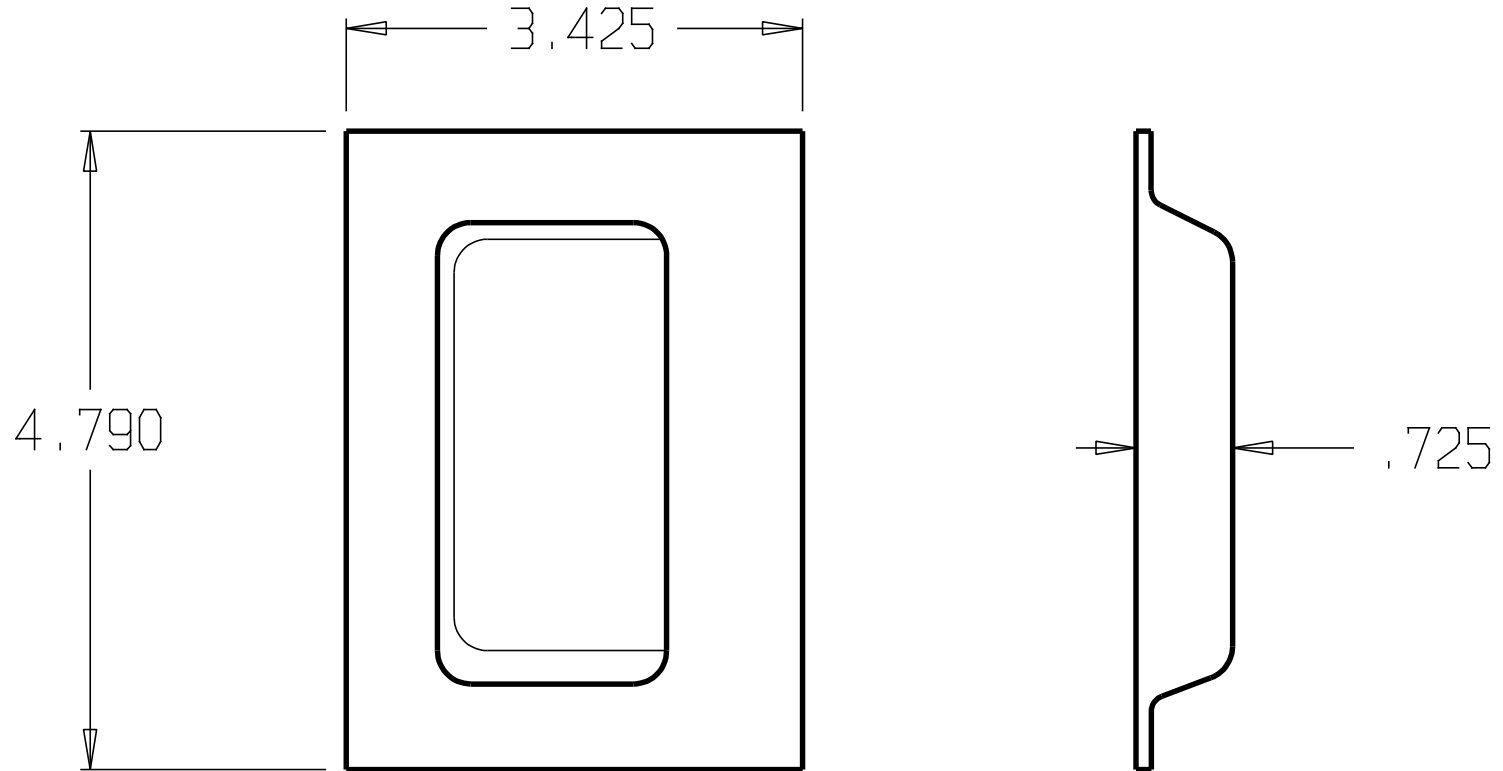

DON-JO MFG. INC.

| | | | | |
|----------|-------|--------------|----------|-------|
| DESIGNER | SIZE | DATE: | PART NO. | REV |
| | A | 4/1/04 | #1848 | |
| APPROVED | SCALE | RELEASE DATE | WEIGHT | SHEET |

| REVISIONS | | | |
|-----------|-----|------------|----------|
| ZONE | REV | FINISHES : | DATE |
| | | 630 | |
| | | | APPROVED |

CUT OUT NEEDED
2 3/4" X 3 3/4"

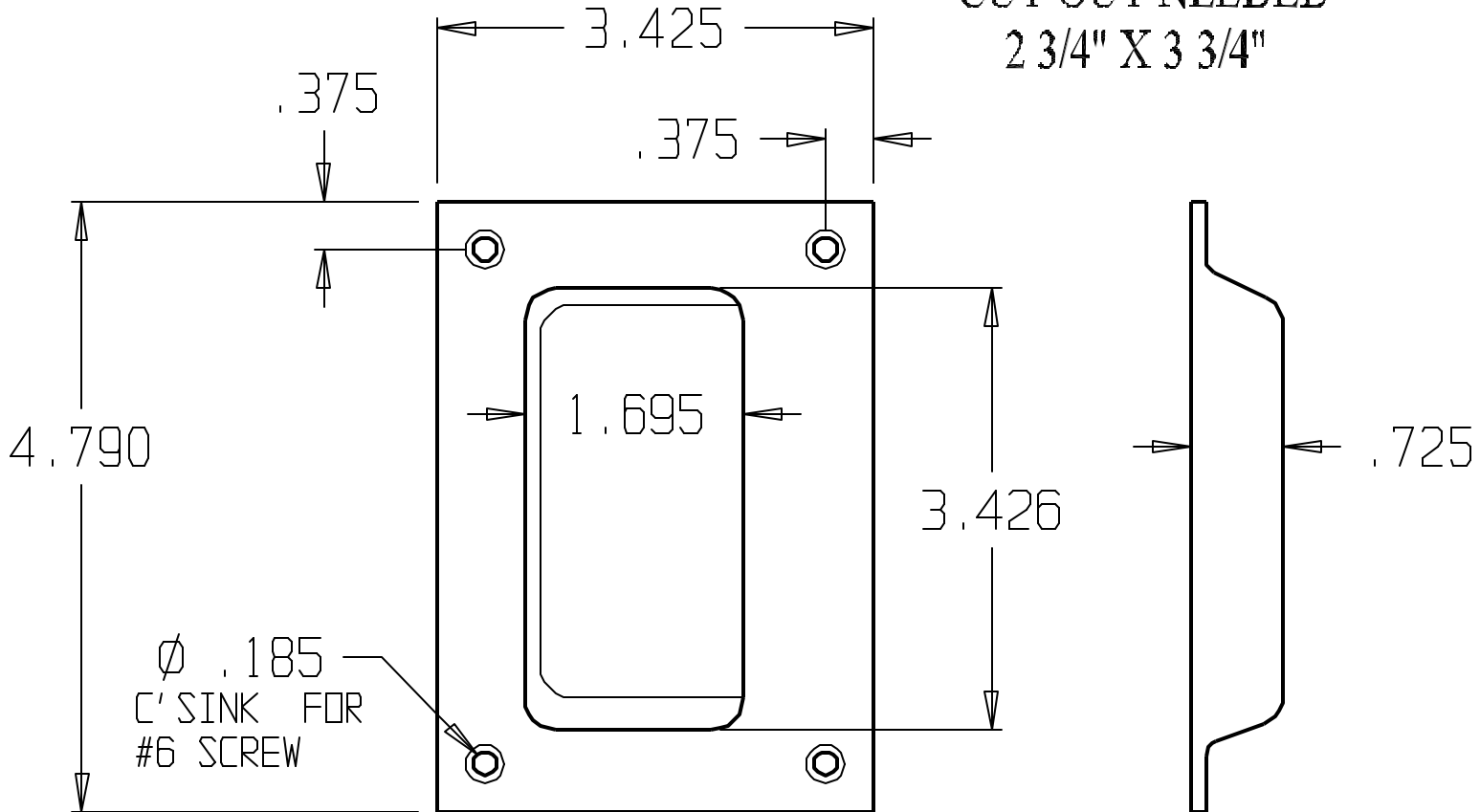

DON-JO MFG. INC.

| | | | | |
|----------|-----------|-----------------|-------------------|-------|
| DESIGNER | SIZE A | DATE: 4/1/04 | PART NO. #1850 | REV |
| APPROVED | SCALE | RELEASE DATE | WEIGHT | SHEET |

| REVISIONS | | | | |
|-----------|-----|-----------|------|----------|
| ZONE | REV | FINISHES: | DATE | APPROVED |
| | | 630 | | |

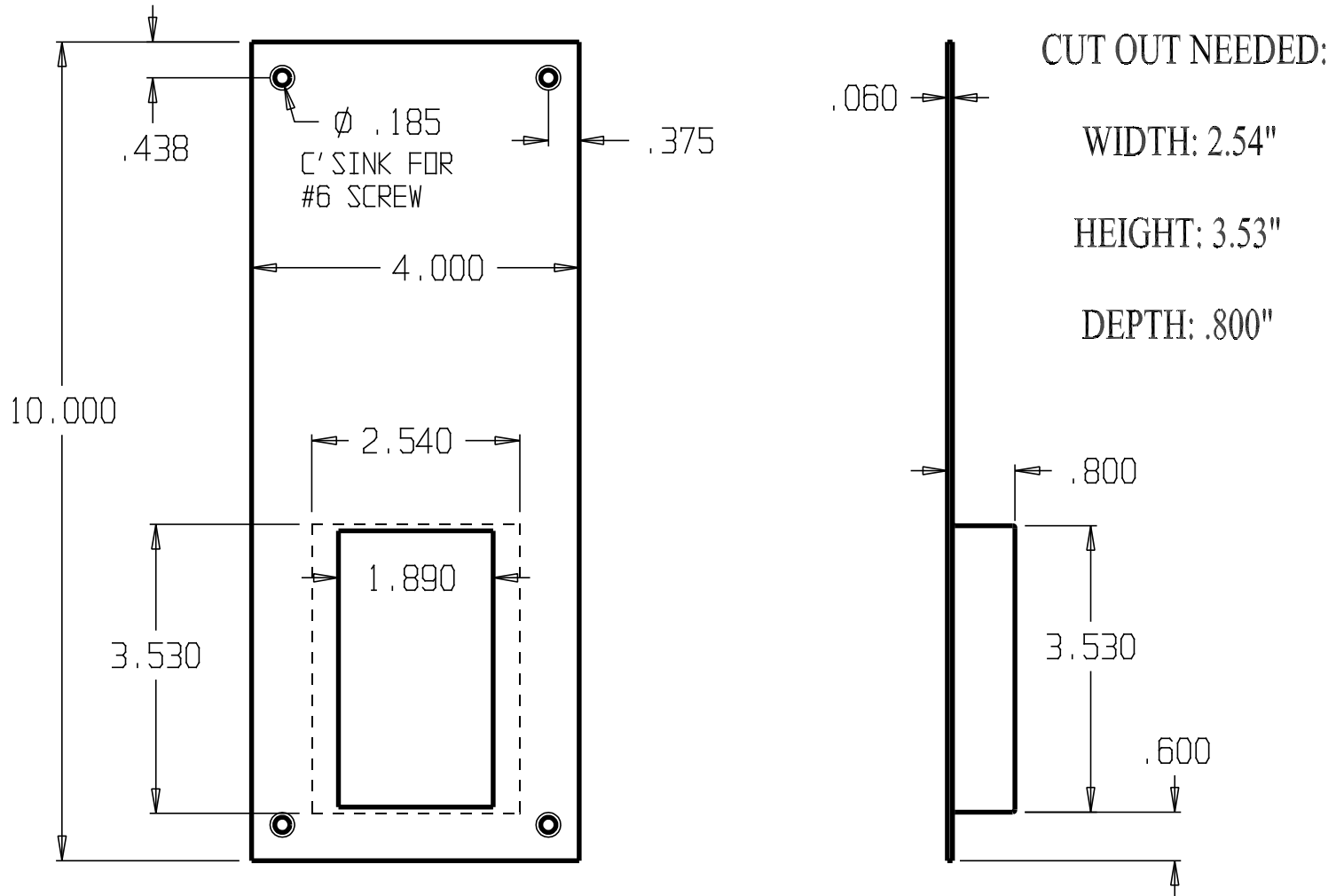

DON-JO MFG. INC.

| | | | | |
|----------|-------|--------------|----------|-------|
| DESIGNER | SIZE | DATE: | PART NO. | REV |
| | A | 4/1/04 | #1858 | |
| APPROVED | SCALE | RELEASE DATE | WEIGHT | SHEET |

| REVISIONS | | | | |
|-----------|-----|-----------|------|----------|
| ZONE | REV | FINISHES: | DATE | APPROVED |
| | | 630 | | |

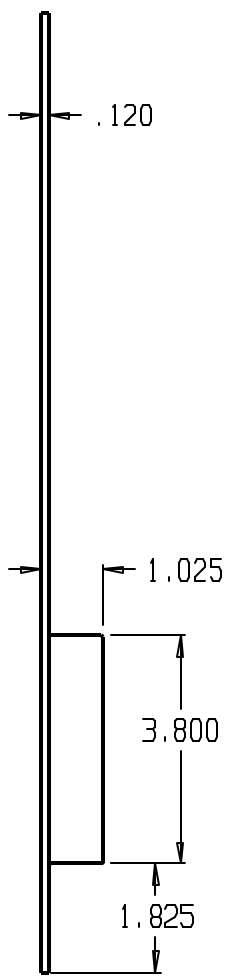
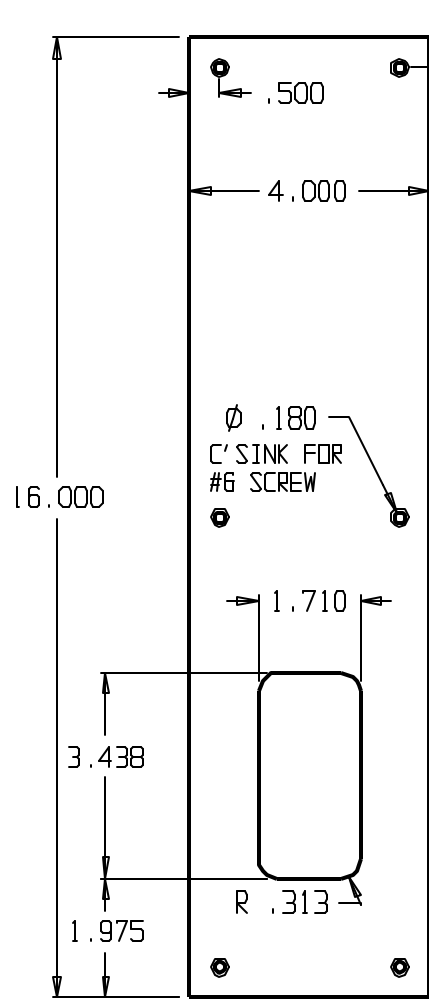

CUT OUT NEEDED
 WIDTH: 3.1"
 HEIGHT: 3.850"
 DEPTH: .875"

DON-JO MFG. INC.

DESIGNER
 APPROVED

| | | | |
|-----------|----------------|-------------------|-------|
| SIZE A | DATE 4/1/04 | PART NO. #1860 | REV |
| SCALE | RELEASE DATE | WEIGHT | SHEET |

| REVISIONS | | | | |
|-----------|-----|-----------|------|----------|
| ZONE | REV | FINISHES: | DATE | APPROVED |
| | | 630 | | |

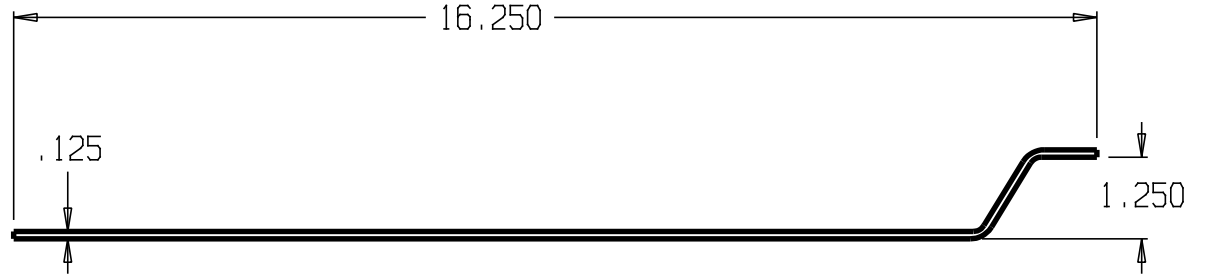
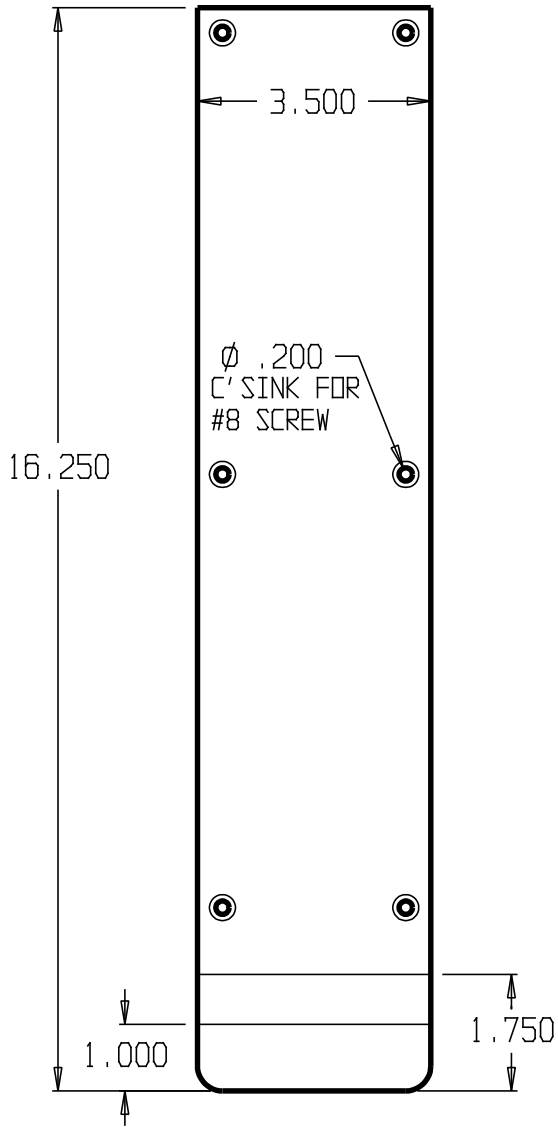

DON-JO MFG. INC.

| | | | | |
|----------|-------|--------------|----------|-------|
| DESIGNER | SIZE | DATE: | PART NO. | REV |
| | A | 4/1/04 | #1866 | |
| APPROVED | SCALE | RELEASE DATE | WEIGHT | SHEET |
| | | | | |

| REVISIONS | | | | |
|-----------|-----|-----------|------|----------|
| ZONE | REV | FINISHES: | DATE | APPROVED |
| | | 630 | | |

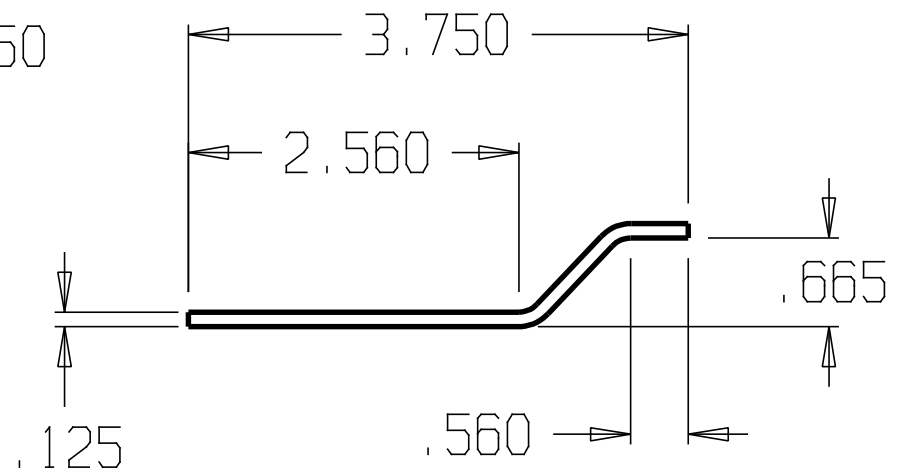
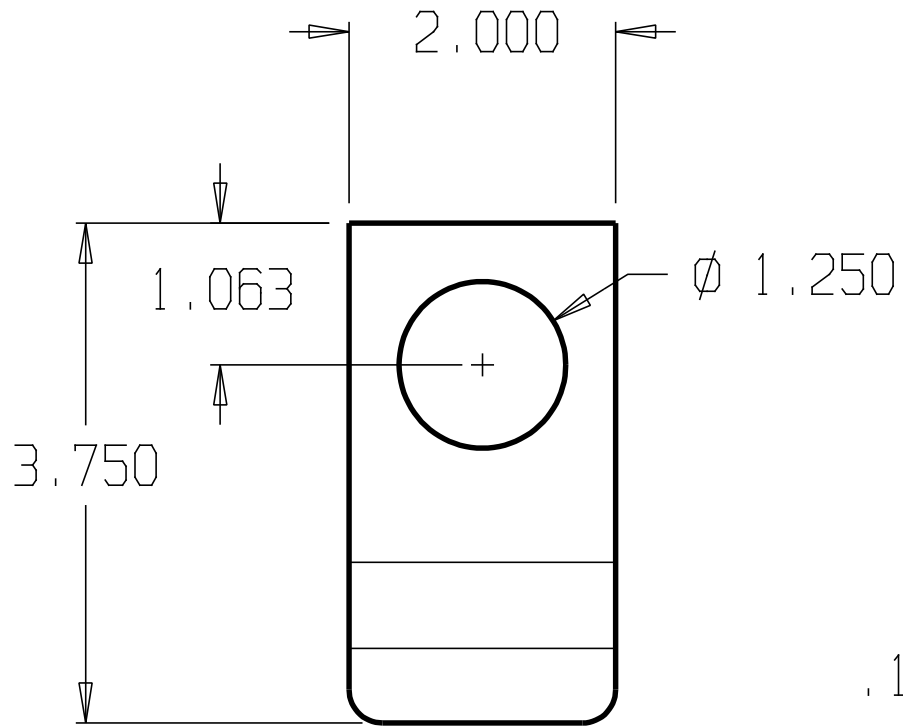

| | | | | |
|------------------|-------|--------------|----------|-------|
| DON-JO MFG. INC. | | | | |
| DESIGNER | SIZE | DATE: | PART NO. | REV |
| | A | 4/1/04 | #1874 | |
| APPROVED | SCALE | RELEASE DATE | WEIGHT | SHEET |

| REVISIONS | | | |
|-----------|-----|-----------|------------|
| ZONE | REV | FINISHES: | GAUGE: |
| | | 630 | 11ga .125" |

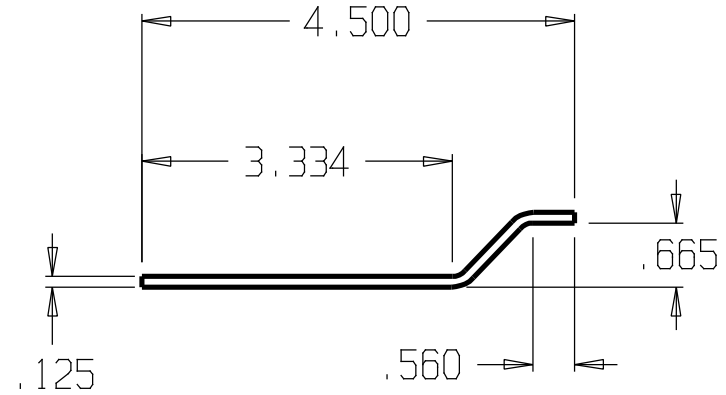
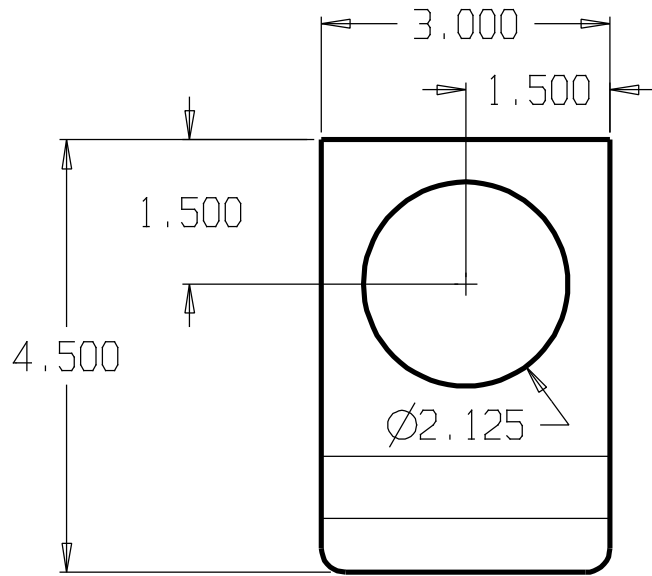

DON-JO MFG. INC.

DESIGNER D.R.

| | | | |
|-----------|-----------------|-------------------|-------|
| SIZE A | DATE: 2/8/12 | PART NO. #1875 | REV |
| SCALE | RELEASE DATE | WEIGHT | SHEET |

| REVISIONS | | | | |
|-----------|-----|------------|------|----------|
| ZONE | REV | FINISHES : | DATE | APPROVED |
| | | | | |

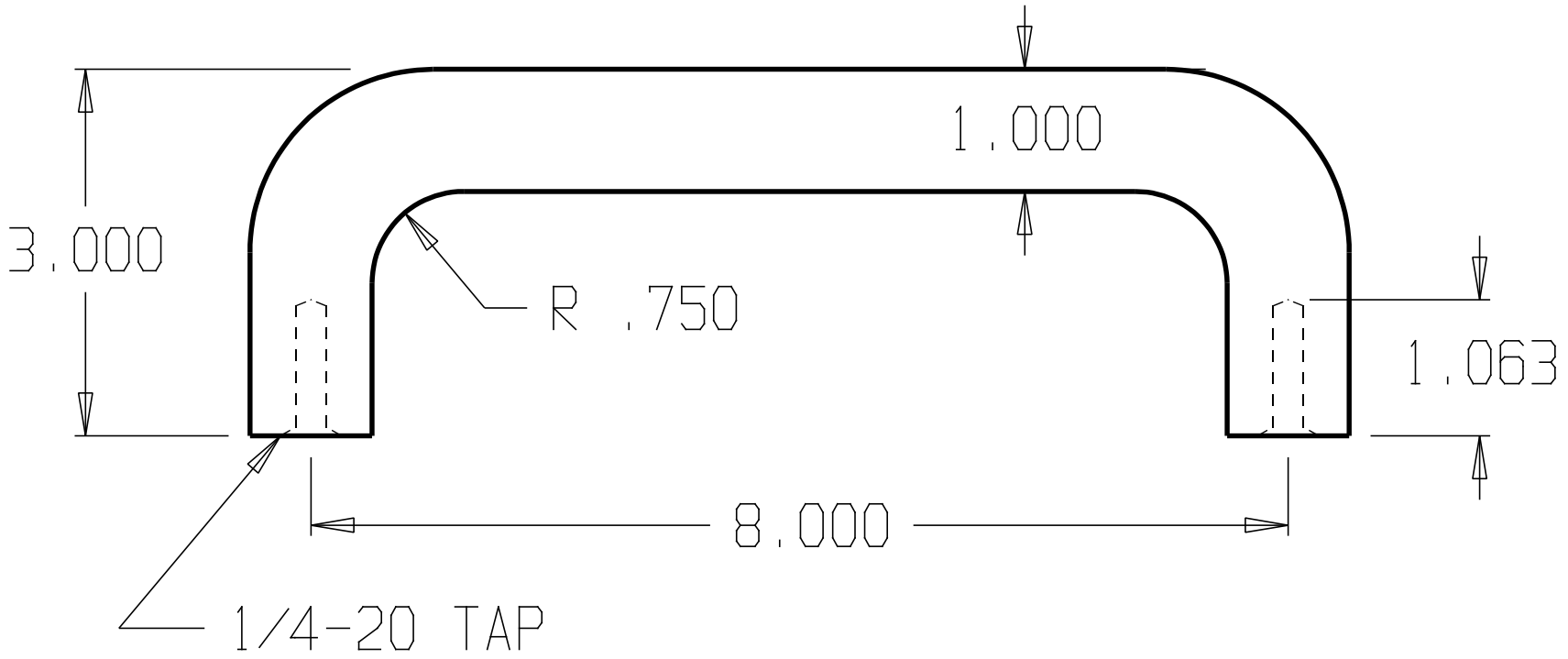

| | | | | |
|------------------|-------|--------------|----------|-------|
| DON-JO MFG. INC. | | | | |
| DESIGNER | SIZE | DATE: | PART NO. | REV |
| | A | | | |
| APPROVED | SCALE | RELEASE DATE | WEIGHT | SHEET |
| | | | | |

| REVISIONS | | | | |
|-----------|-----|-----------------------------------|------|----------|
| ZONE | REV | FINISHES: | DATE | APPROVED |
| | | 605, 606, 612, 613, 628, 629, 630 | | |

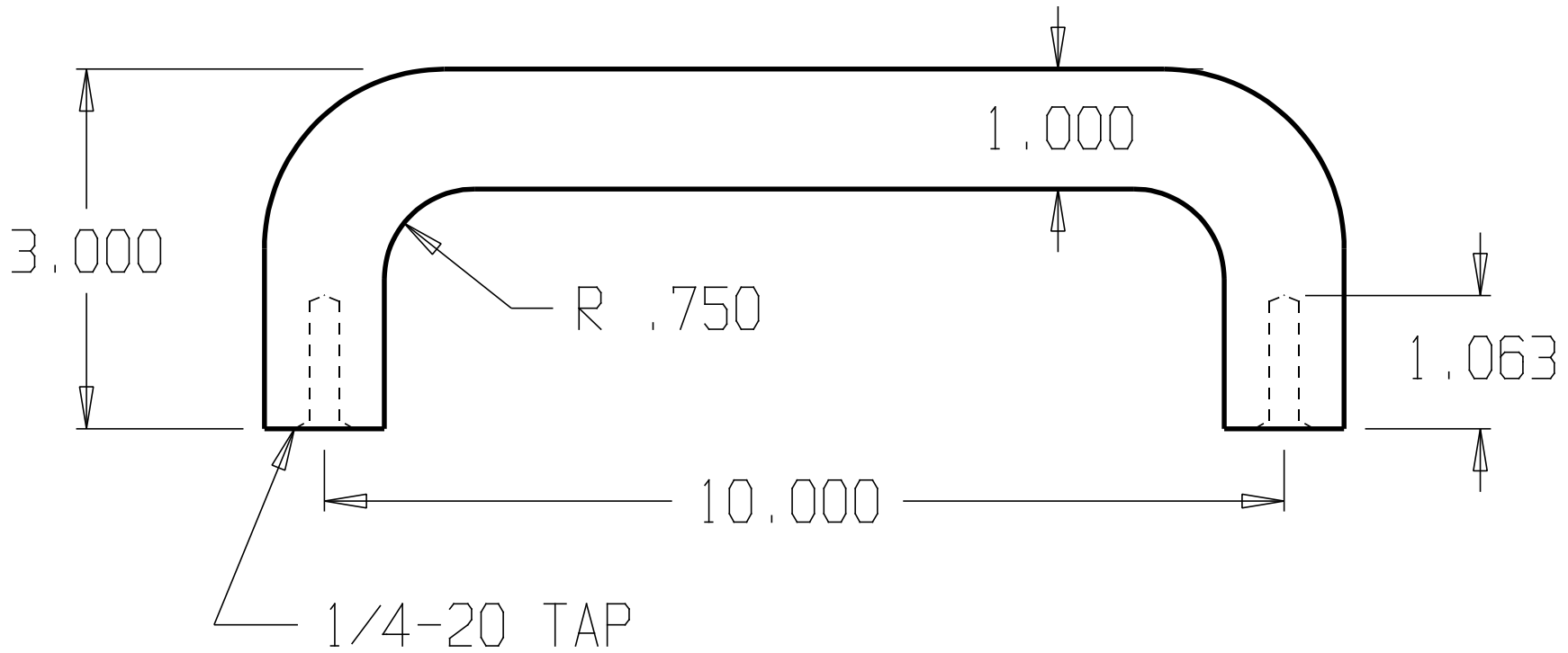

DON-JO MFG. INC.

| | | | | |
|----------|-------|--------------|----------|-------|
| DESIGNER | SIZE | DATE: | PART NO. | REV |
| | A | 4/1/04 | #20 | |
| APPROVED | SCALE | RELEASE DATE | WEIGHT | SHEET |
| | | | | |

| REVISIONS | | | | |
|-----------|-----|-----------------------------------|------|----------|
| ZONE | REV | FINISHES: | DATE | APPROVED |
| | | 605, 606, 612, 613, 628, 629, 630 | | |

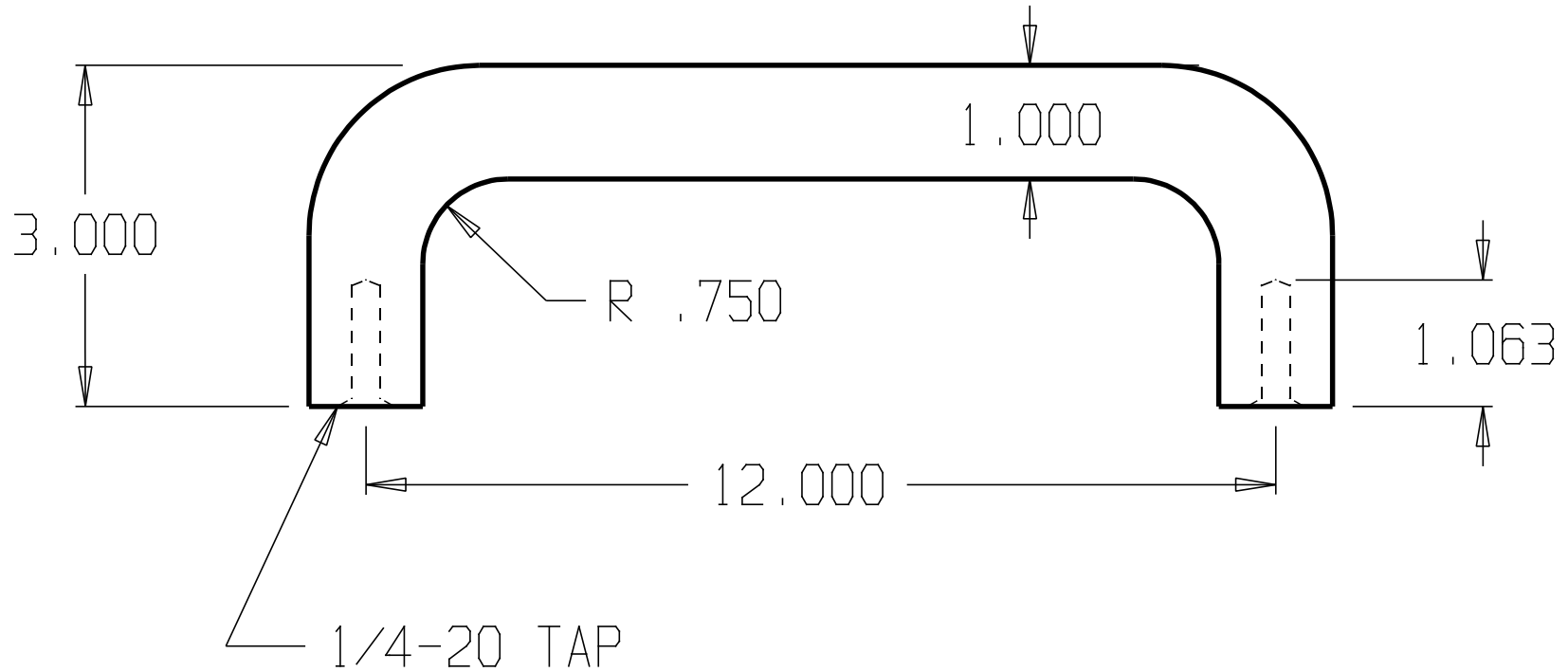

DON-JO MFG. INC.

| | |
|----------|--|
| DESIGNER | |
| APPROVED | |

| | | | |
|-----------|-----------------|-----------------|-------|
| SIZE A | DATE: 4/5/04 | PART NO. #21 | REV |
| SCALE | RELEASE DATE | WEIGHT | SHEET |

| REVISIONS | | | | |
|-----------|-----|-----------------------------------|------|----------|
| ZONE | REV | FINISHES: | DATE | APPROVED |
| | | 605, 606, 612, 613, 628, 629, 630 | | |

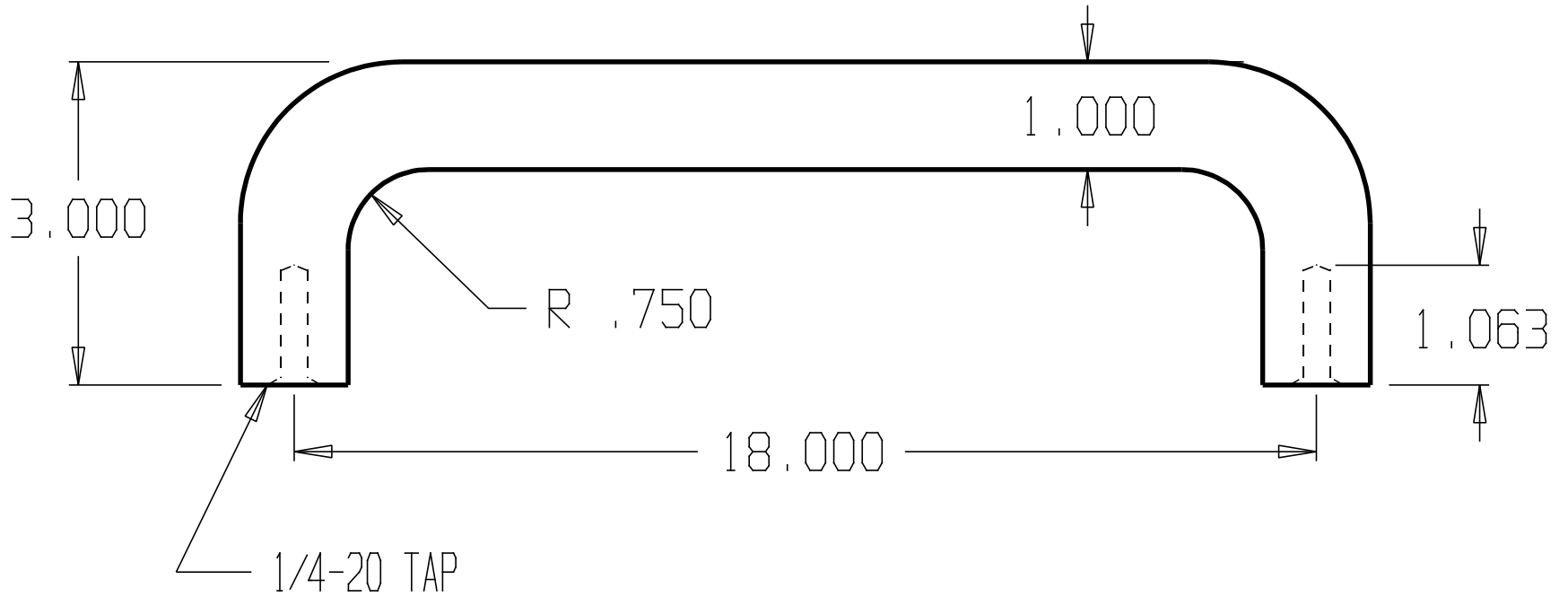

| | | | | |
|------------------|-------|--------------|----------|-------|
| DON-JO MFG. INC. | | | | |
| DESIGNER | SIZE | DATE: | PART NO. | REV |
| | A | 4/5/04 | #22 | |
| APPROVED | SCALE | RELEASE DATE | WEIGHT | SHEET |

| REVISIONS | | | | |
|-----------|-----|-----------------|------|----------|
| ZONE | REV | FINISHES: | DATE | APPROVED |
| | | 605,613,628,630 | | |

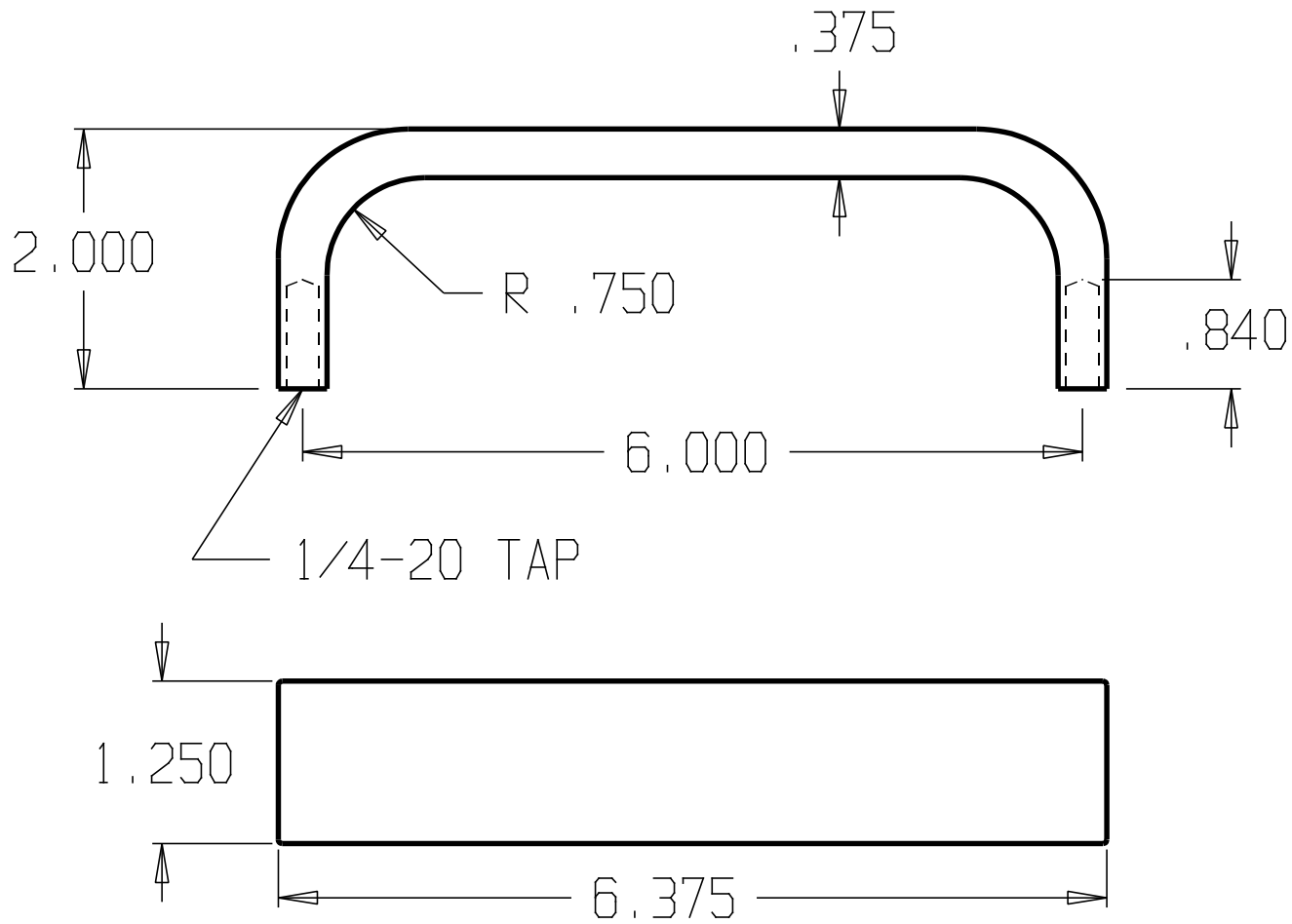

DON-JO MFG. INC.

| | |
|----------|--|
| DESIGNER | |
| APPROVED | |

| | | | |
|-------|--------------|----------|-------|
| SIZE | DATE: | PART NO. | REV |
| A | 4/19/04 | #30 | |
| SCALE | RELEASE DATE | WEIGHT | SHEET |

| REVISIONS | | | | |
|-----------|-----|-----------------|------|----------|
| ZONE | REV | FINISHES: | DATE | APPROVED |
| | | 605,613,628,630 | | |

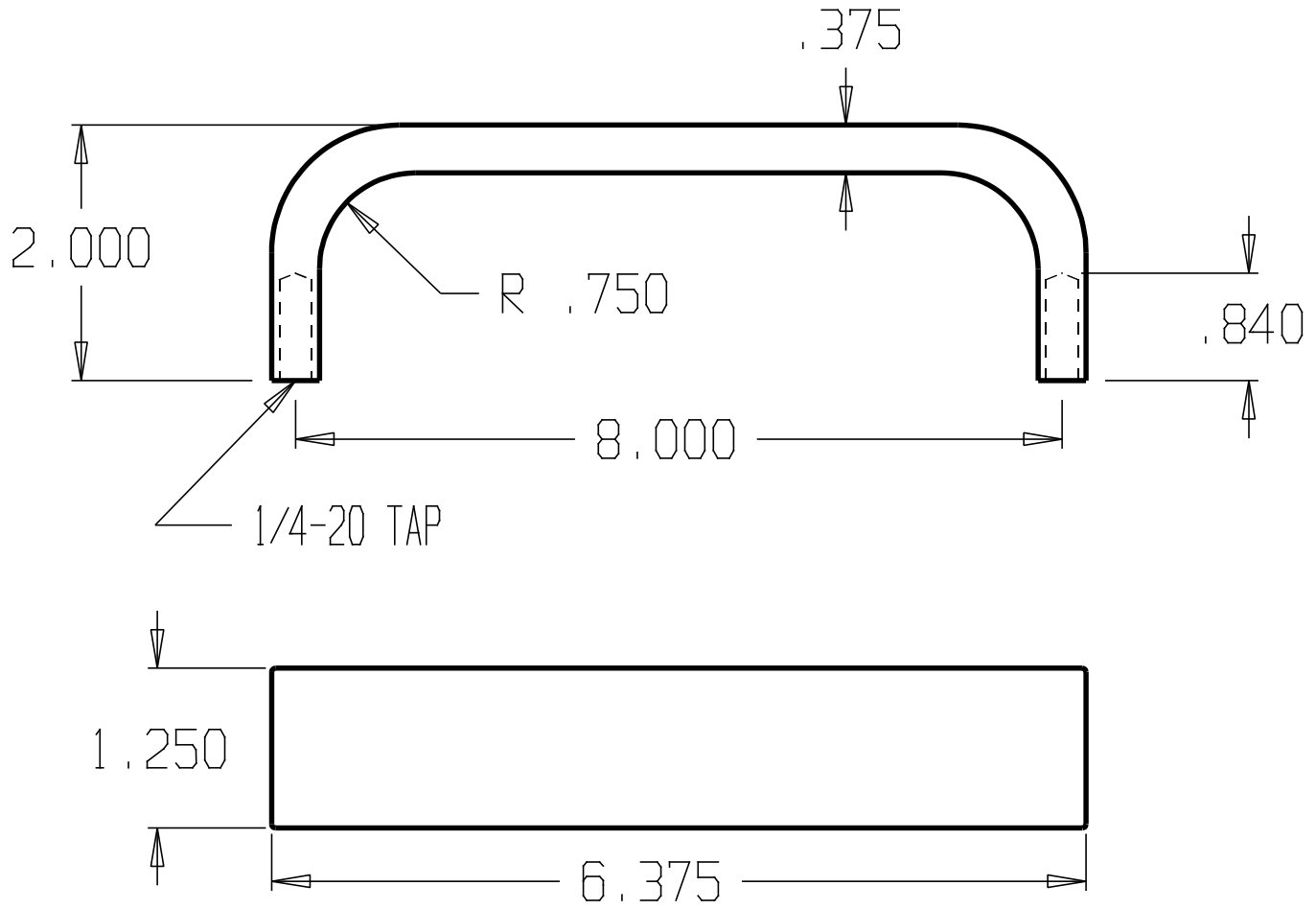

DON-JO MFG. INC.

| | | | | |
|----------|-------|--------------|----------|-------|
| DESIGNER | SIZE | DATE: | PART NO. | REV |
| | A | 4/19/04 | #31 | |
| APPROVED | SCALE | RELEASE DATE | WEIGHT | SHEET |

| REVISIONS | | | | |
|-----------|-----|-----------------|------|----------|
| ZONE | REV | FINISHES: | DATE | APPROVED |
| | | 605,613,628,630 | | |

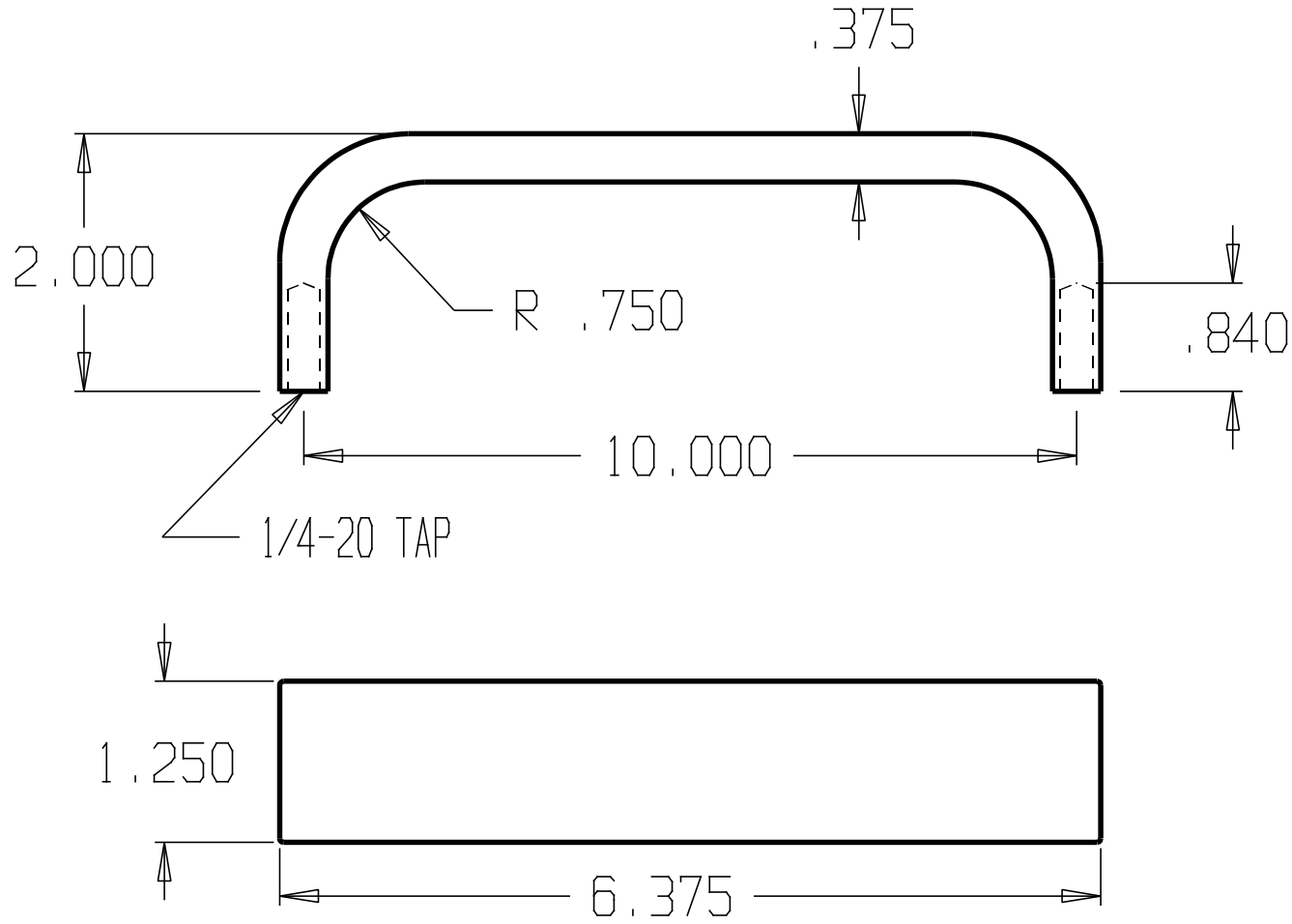

DON-JO MFG. INC.

| | | | | |
|----------|-------|--------------|----------|-------|
| DESIGNER | SIZE | DATE: | PART NO. | REV |
| | A | 4/19/04 | #32 | |
| APPROVED | SCALE | RELEASE DATE | WEIGHT | SHEET |

| REVISIONS | | | | |
|-----------|-----|--------------------|------|----------|
| ZONE | REV | FINISHES: | DATE | APPROVED |
| | | 605, 613, 625, 626 | | |

Ø 2.000

Ø .195
C' SINK FOR
10 SCREW

1.000

1.000

1.875

5.500

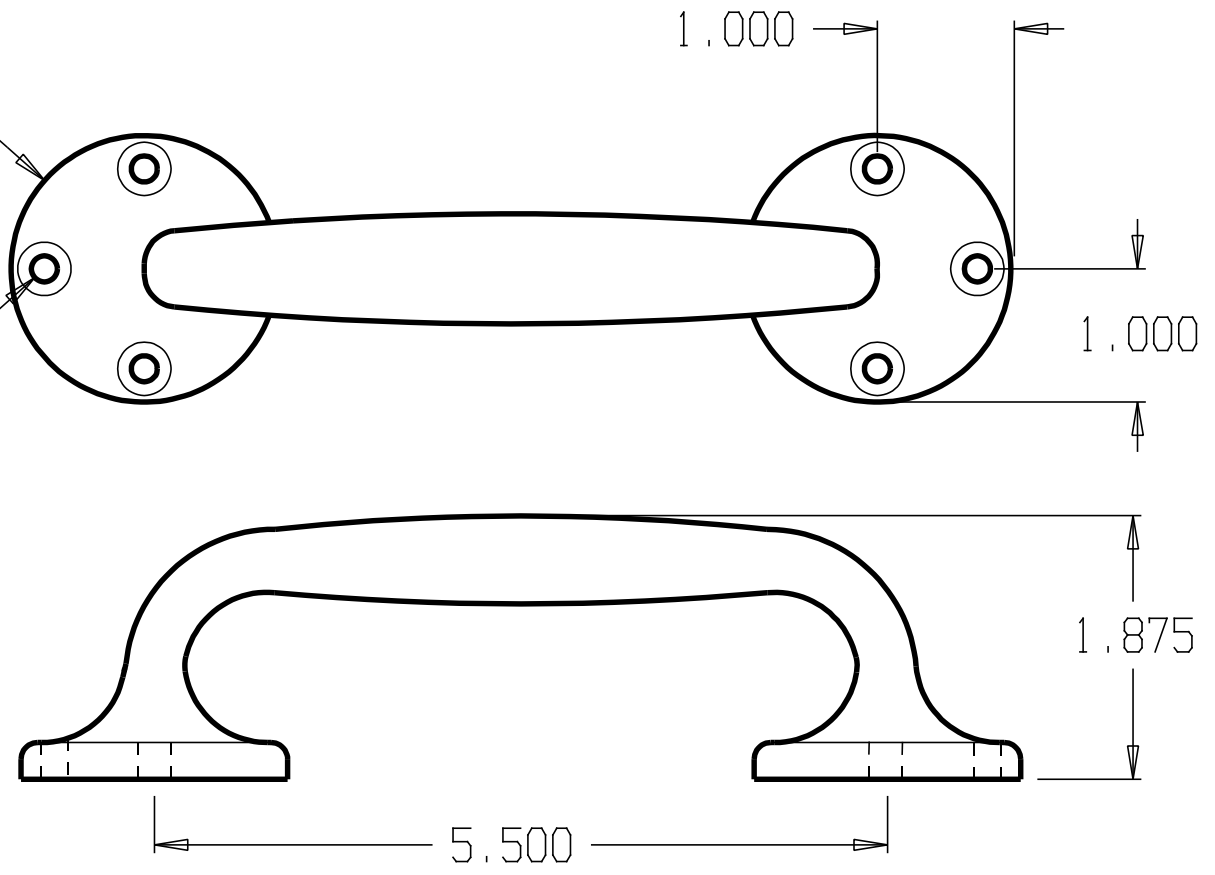

DON-JO MFG. INC.

| | | | | |
|----------|-----------|------------------|-----------------|-------|
| DESIGNER | SIZE A | DATE: 4/27/04 | PART NO. #35 | REV |
| APPROVED | SCALE | RELEASE DATE | WEIGHT | SHEET |

| REVISIONS | | | | |
|-----------|-----|--------------------|------|----------|
| ZONE | REV | FINISHES: | DATE | APPROVED |
| | | 605, 613, 625, 626 | | |

Ø 2.000

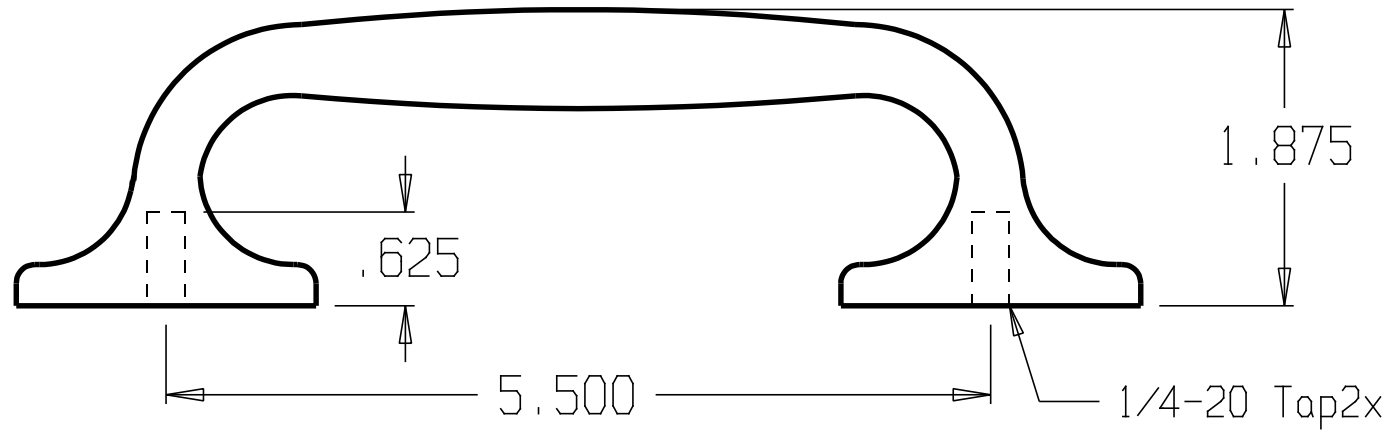
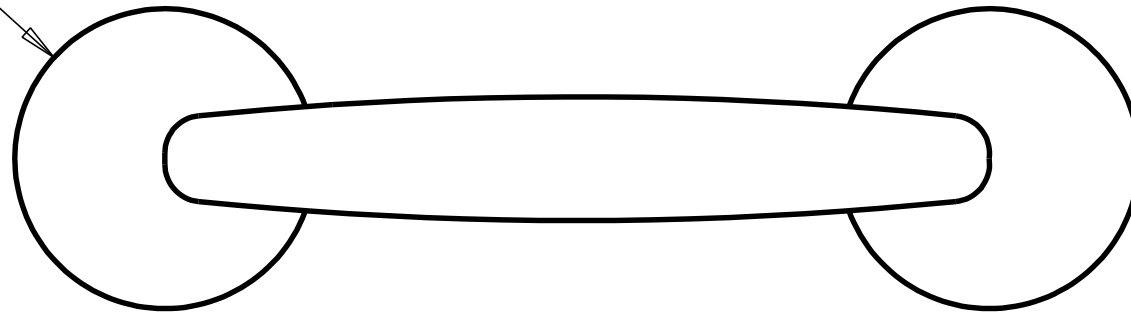

DON-JO MFG. INC.

| | | | | |
|----------|-------|--------------|----------|-------|
| DESIGNER | SIZE | DATE: | PART NO. | REV |
| | A | 4/27/04 | #36 | |
| APPROVED | SCALE | RELEASE DATE | WEIGHT | SHEET |

| REVISIONS | | | |
|-----------|-----|--------------------|------|
| ZONE | REV | FINISHES : | DATE |
| | | 605, 613, 628, 630 | |
| | | APPROVED | |

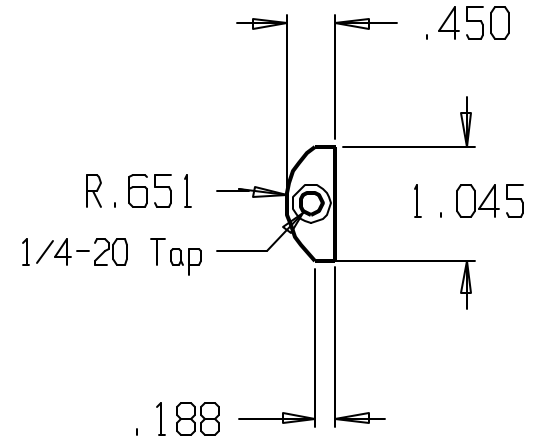
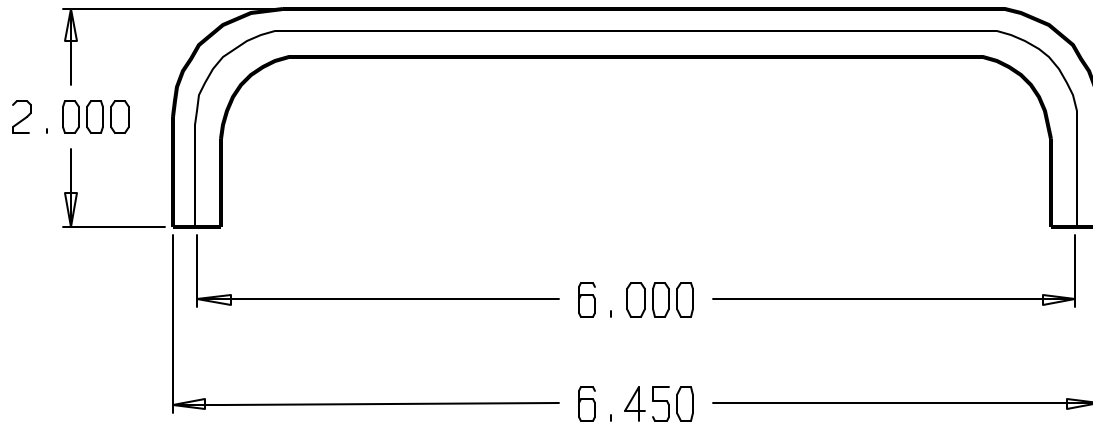

DON-JO MFG. INC.

| | | | | |
|----------|-------|--------------|----------|-------|
| DESIGNER | SIZE | DATE | PART NO. | REV |
| | A | 4/27/04 | #37 | |
| APPROVED | SCALE | RELEASE DATE | WEIGHT | SHEET |

| REVISIONS | | | |
|-----------|-----|--------------------|------|
| ZONE | REV | FINISHES: | DATE |
| | | 605, 613, 626, 630 | |
| | | APPROVED | |

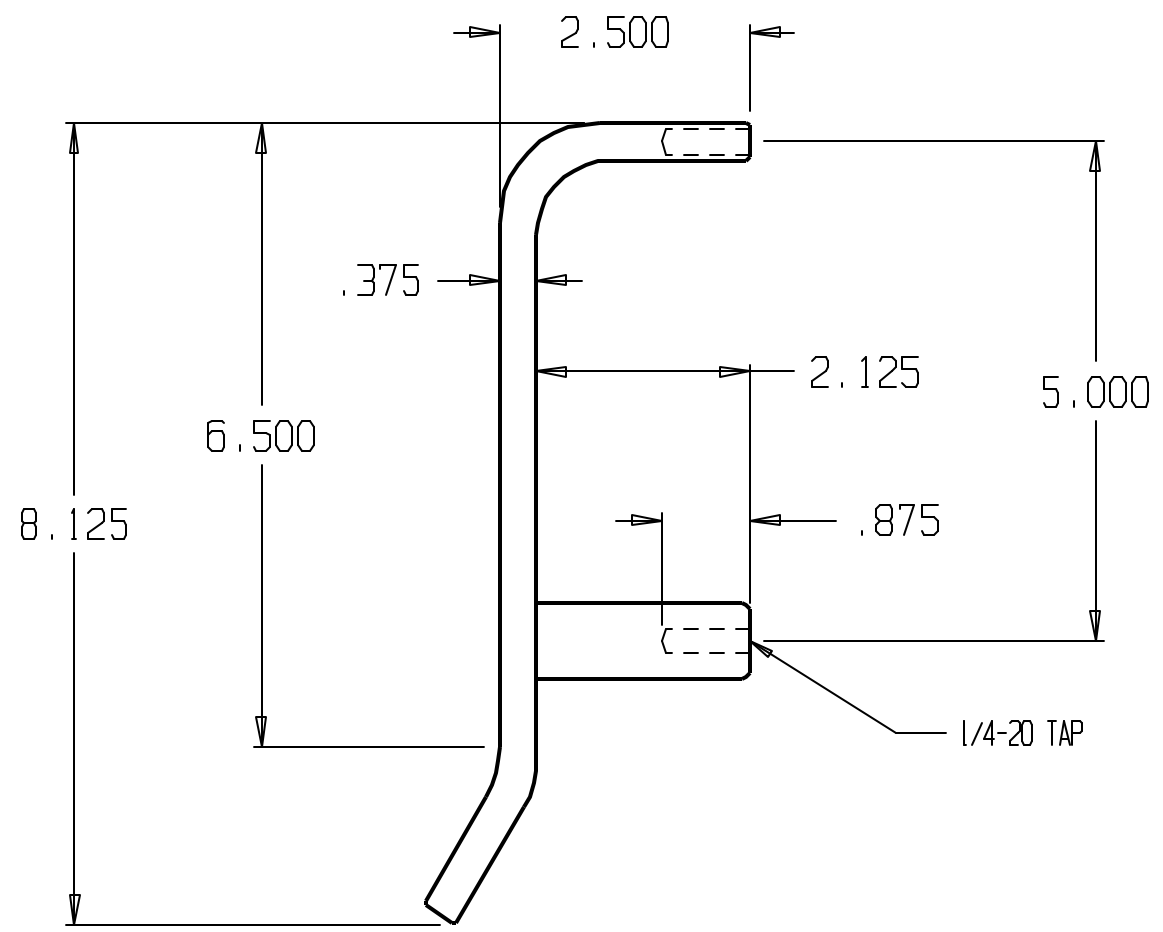

DON-JO MFG. INC.

| | | | | |
|----------|-------|--------------|----------|-------|
| DESIGNER | SIZE | DATE | PART NO. | REV |
| | A | 4/28/04 | #42 | |
| APPROVED | SCALE | RELEASE DATE | WEIGHT | SHEET |

| REVISIONS | | |
|-----------|-----|---------------|
| ZONE | REV | FINISHES : |
| | | 605, 613, 630 |
| | | GALUGE : |

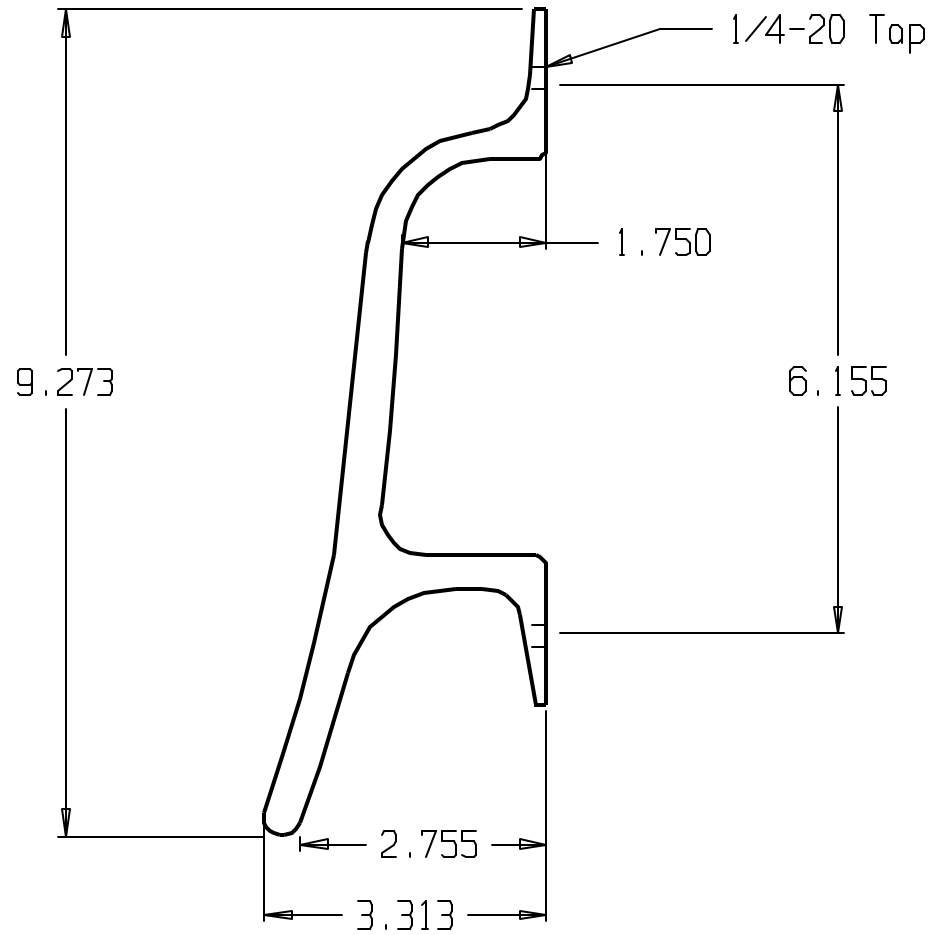

DON-JO MFG. INC.

| | | | | |
|----------|-------|--------------|----------|-------|
| DESIGNER | SIZE | DATE | PART NO. | REV |
| D. R. | A | 4/28/04 | #44 | |
| | SCALE | RELEASE DATE | WEIGHT | SHEET |

| REVISIONS | | | |
|-----------|-----|------------|------------|
| ZONE | REV | FINISHES : | GUAGE : |
| | | 630 | 13ga. .090 |

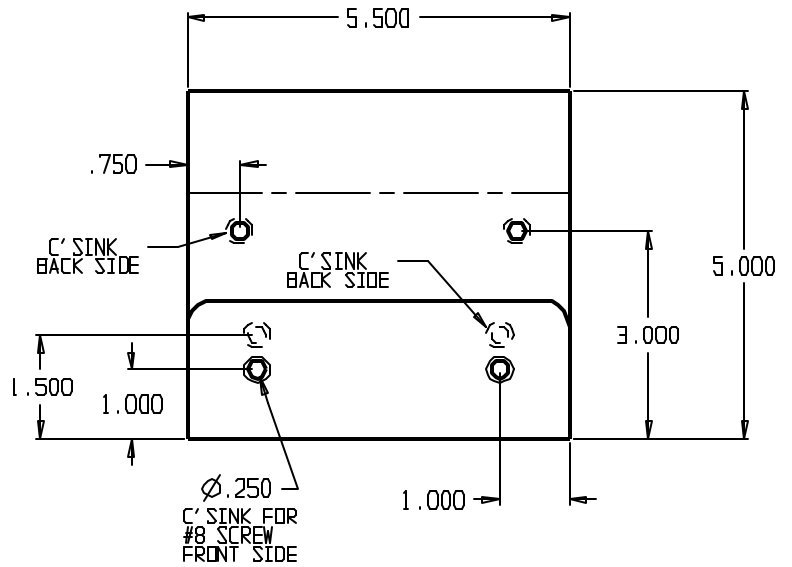
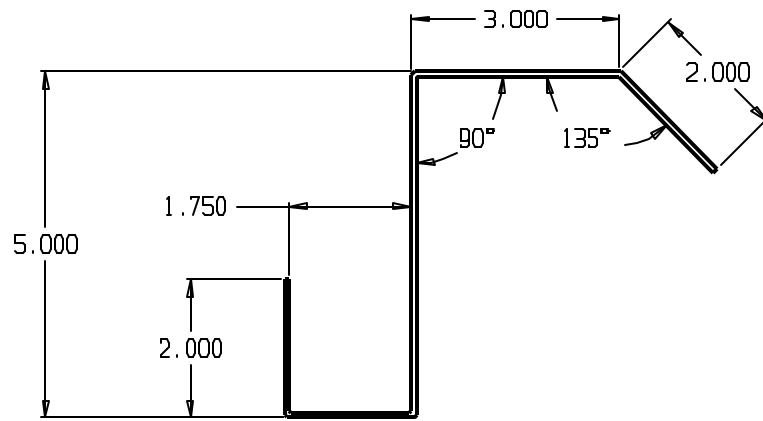

DON-JO MFG. INC.

| | | | | |
|----------|-------|--------------|----------|-------|
| DESIGNER | SIZE | DATE | PART NO. | REV |
| D.R. | A | 11/15/07 | #46 | |
| | SCALE | RELEASE DATE | WEIGHT | SHEET |

| REVISIONS | | | |
|-----------|-----|---------------------|------|
| ZONE | REV | FINISHES: | DATE |
| | | 605,613,619,620,626 | |
| | | APPROVED | |

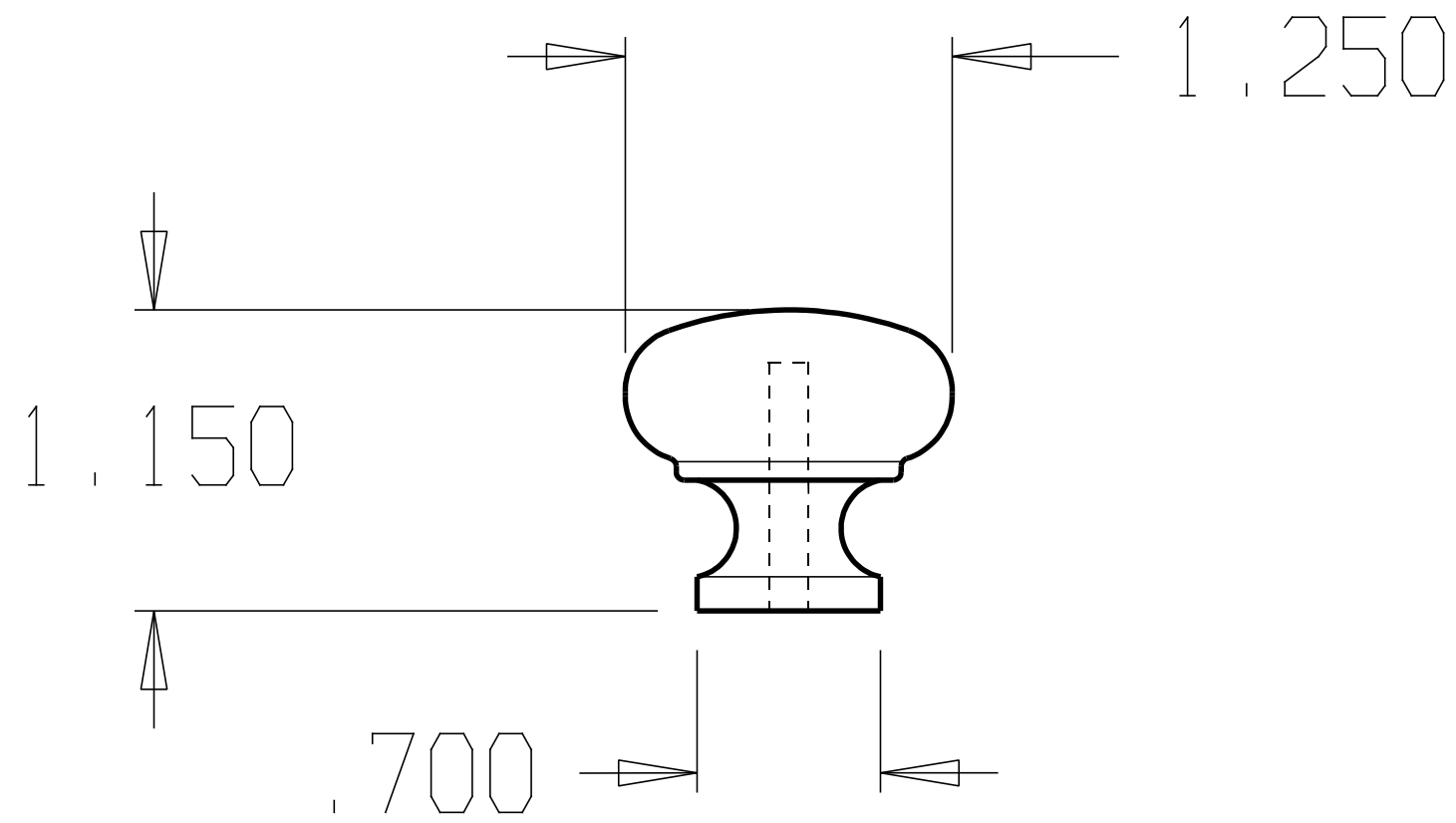

DON-JO MFG. INC.

| | | | | |
|----------|-------|--------------|----------|-------|
| DESIGNER | SIZE | DATE: | PART NO. | REV |
| | A | 4/28/04 | #54 | |
| APPROVED | SCALE | RELEASE DATE | WEIGHT | SHEET |

| REVISIONS | | | |
|-----------|-----|-------------------------|------|
| ZONE | REV | FINISHES: | DATE |
| | | 605, 613, 619, 620, 626 | |
| | | APPROVED | |

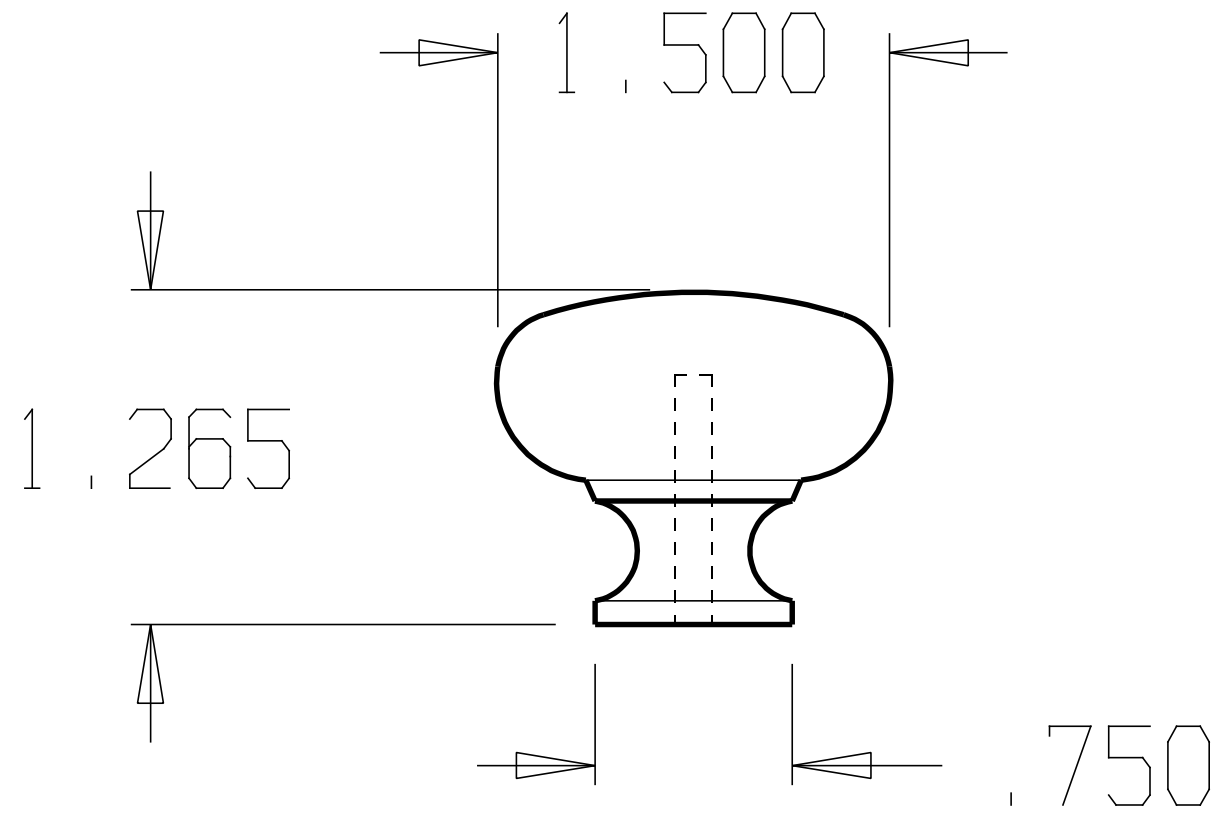

DON-JO MFG. INC.

| | |
|----------|--|
| DESIGNER | |
| APPROVED | |

| | | | |
|-------|--------------|----------|-------|
| SIZE | DATE: | PART NO. | REV |
| A | 4/28/04 | #56 | |
| SCALE | RELEASE DATE | WEIGHT | SHEET |

DWG NO _____ SH _____ REV _____

| REVISIONS | | | |
|-----------|-----|--------------------|----------|
| ZONE | REV | FINISHES: | DATE |
| | | 605, 620, 625, 626 | |
| | | | APPROVED |

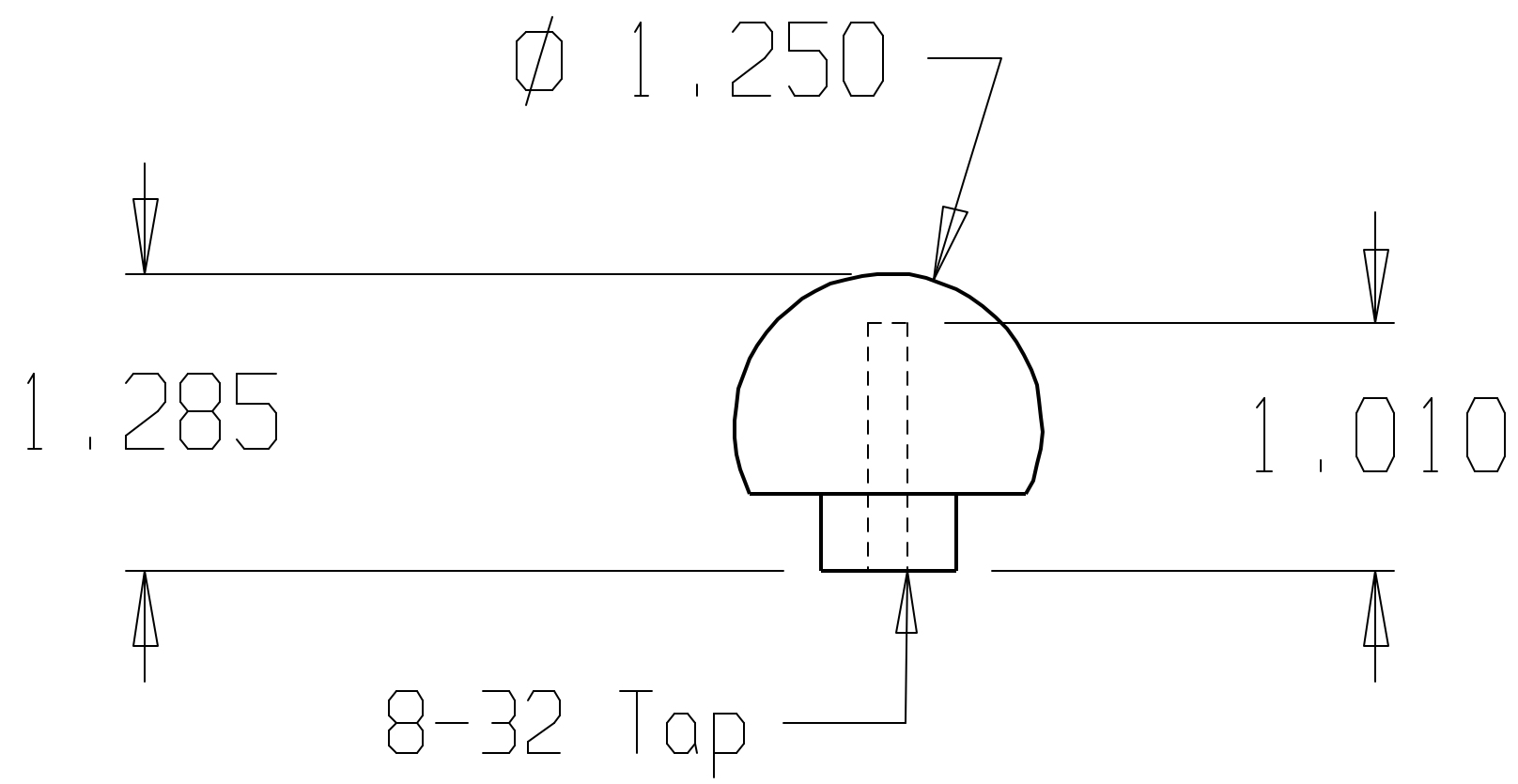

DON-JO MFG. INC.

DESIGNER _____
APPROVED _____

| | | | |
|-----------|------------------|-----------------|--------------|
| SIZE A | DATE: 4/28/04 | PART NO. #58 | REV _____ |
| SCALE | RELEASE DATE | WEIGHT | SHEET |

DWG NO. SH REV

REVISIONS

| ZONE | REV | FINISHES: | DATE | APPROVED |
|------|-----|--------------------|------|----------|
| | | 605, 620, 625, 626 | | |

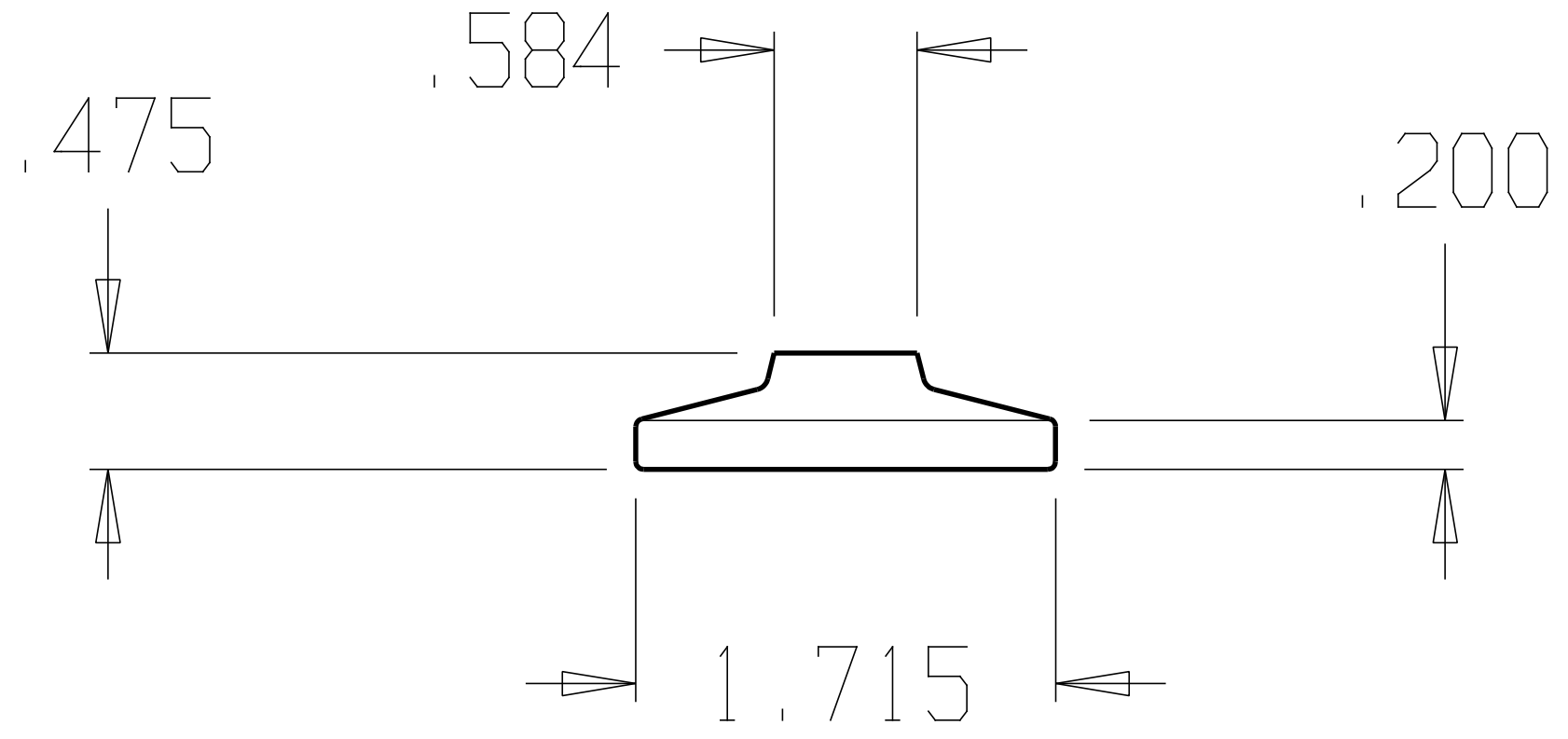

DON-JO MFG. INC.

| | | | | |
|----------|-----------|--------------|-----------------|-------|
| DESIGNER | SIZE A | DATE: | PART NO. #59 | REV |
| APPROVED | SCALE | RELEASE DATE | WEIGHT | SHEET |

| REVISIONS | | | | |
|-----------|-----|---------------|------|----------|
| ZONE | REV | FINISHES: | DATE | APPROVED |
| | | 605, 625, 626 | | |

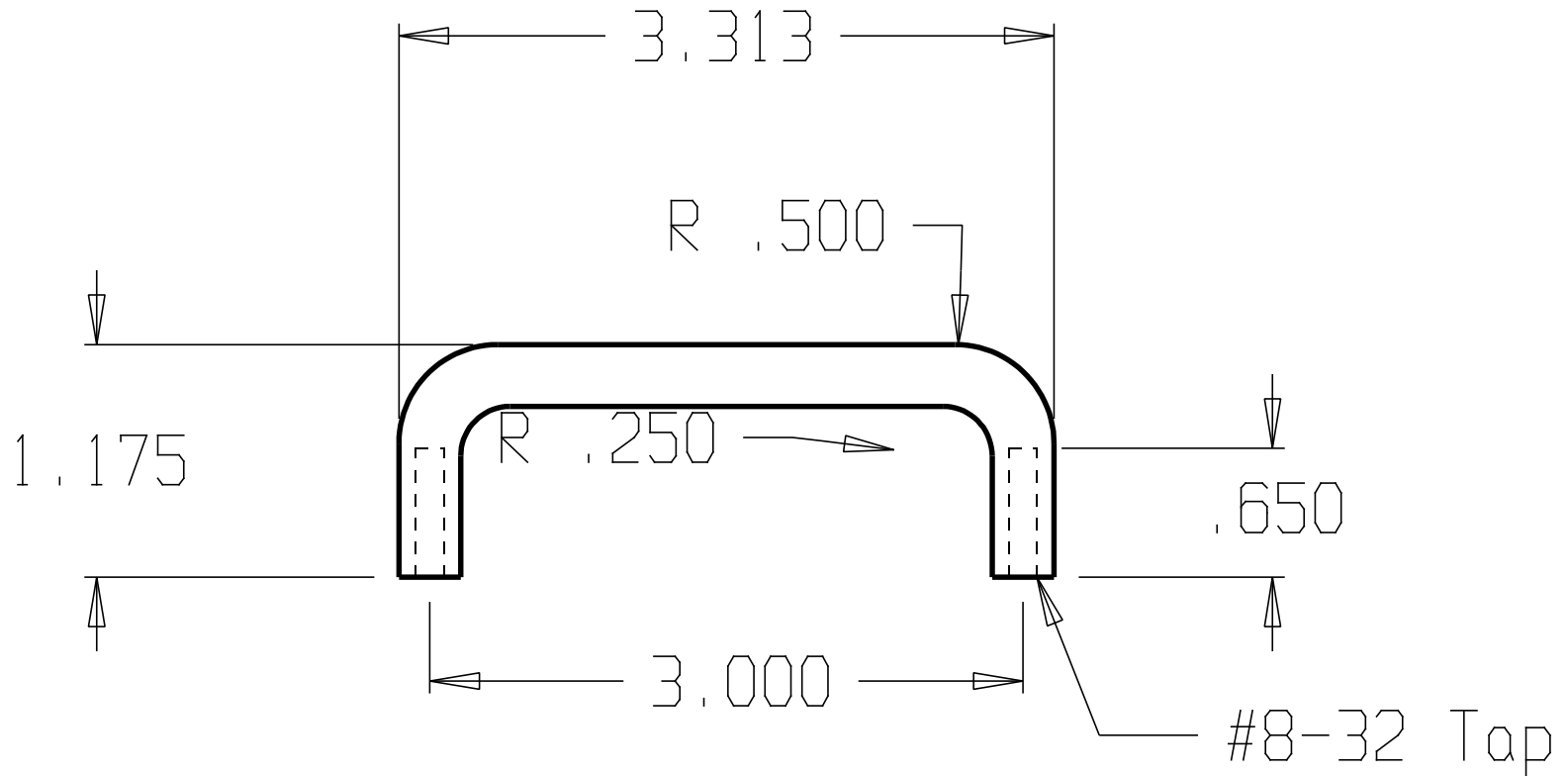

DON-JO MFG. INC.

| | |
|----------|--|
| DESIGNER | |
| APPROVED | |

| | | | |
|-------|--------------|----------|-------|
| SIZE | DATE: | PART NO. | REV |
| A | 4/29/04 | #62 | |
| SCALE | RELEASE DATE | WEIGHT | SHEET |

| REVISIONS | | | | |
|-----------|-----|---------------|------|----------|
| ZONE | REV | FINISHES: | DATE | APPROVED |
| | | 605, 625, 626 | | |

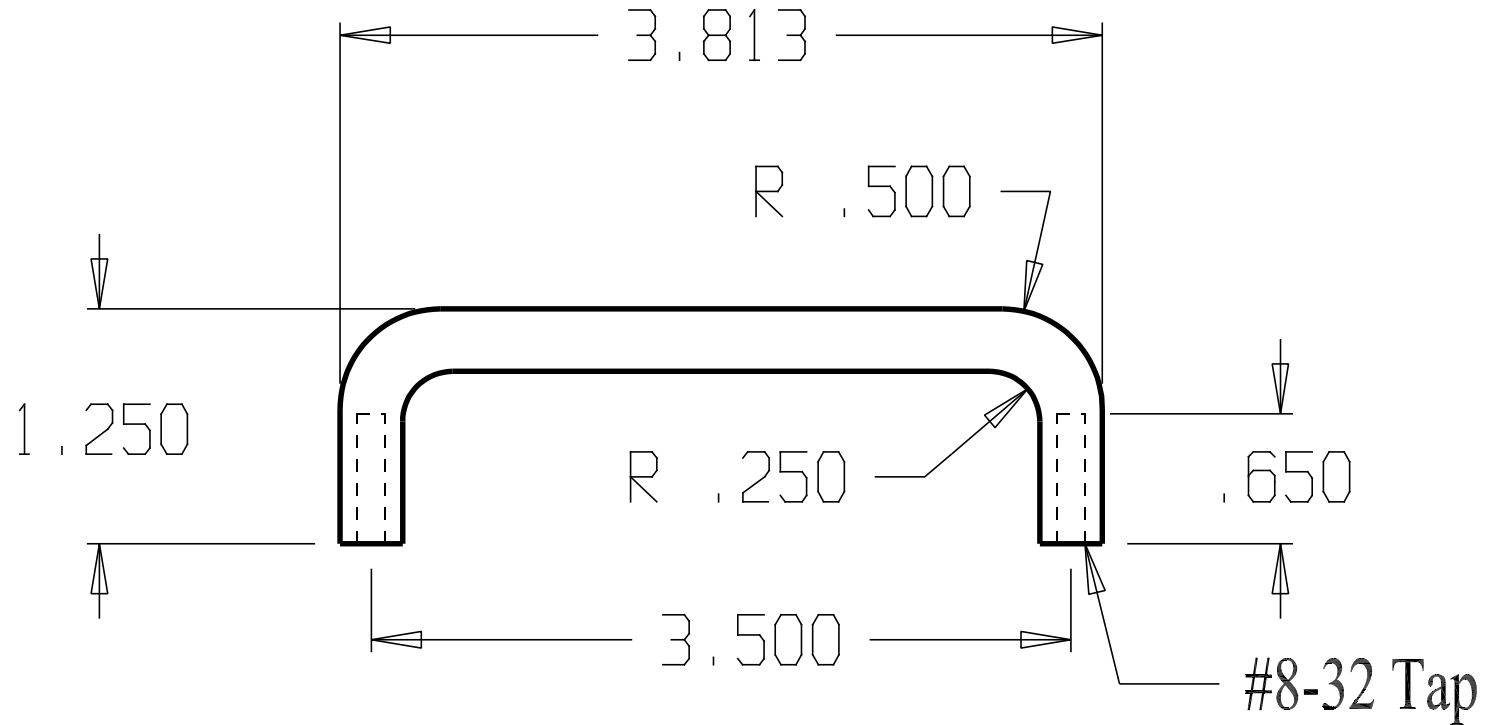

DON-JO MFG. INC.

| | |
|----------|--|
| DESIGNER | |
| APPROVED | |

| | | | |
|-------|--------------|----------|-------|
| SIZE | DATE: | PART NO. | REV |
| A | 4/28/04 | #64 | |
| SCALE | RELEASE DATE | WEIGHT | SHEET |

| REVISIONS | | | |
|-----------|-----|---------------|------|
| ZONE | REV | FINISHES: | DATE |
| | | 605, 625, 626 | |
| | | APPROVED | |

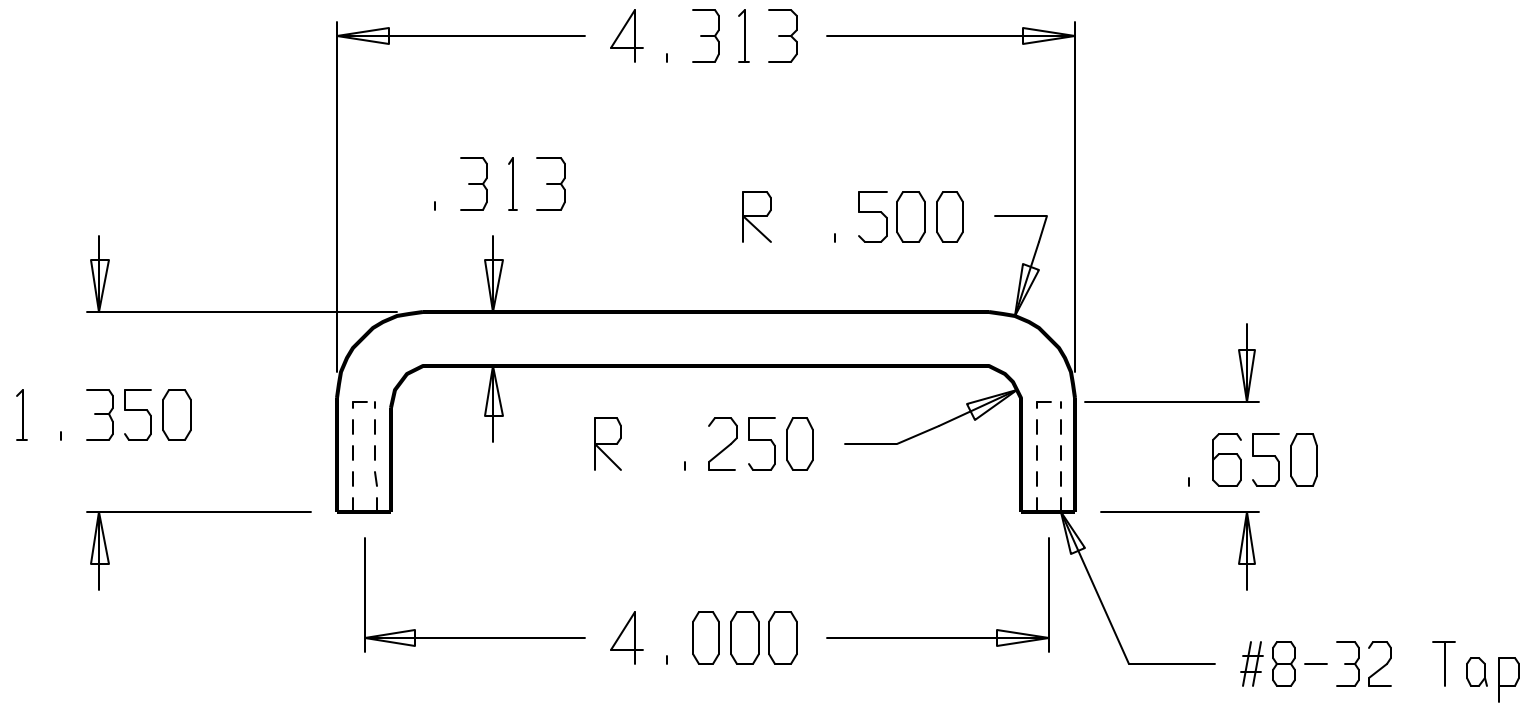

DON-JO MFG. INC.

| | |
|----------|--|
| DESIGNER | |
| APPROVED | |

| | | | |
|-----------|------------------|-----------------|-------|
| SIZE A | DATE: 4/28/04 | PART NO. #66 | REV |
| SCALE | RELEASE DATE | WEIGHT | SHEET |

| REVISIONS | | | | |
|-----------|-----|---|------|----------|
| ZONE | REV | FINISHES: | DATE | APPROVED |
| | | 605,606,609,612,613,619, 620,626,628,629,630 | | |

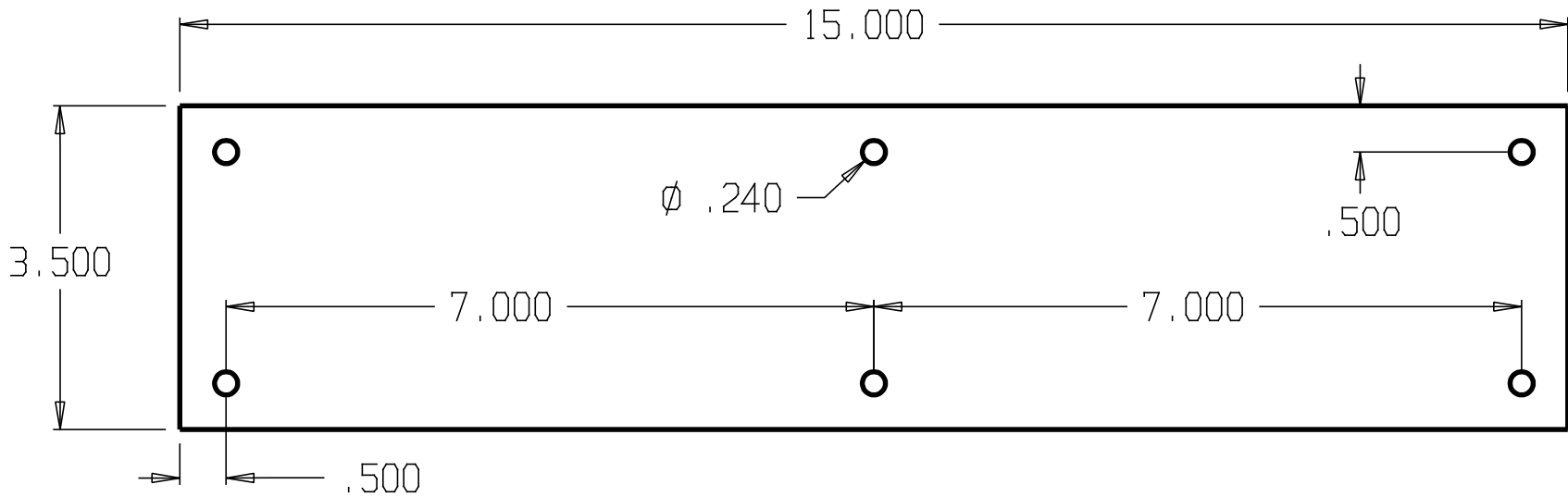

| | | | | |
|------------------|-------|--------------|----------|-------|
| DON-JO MFG. INC. | | | | |
| DESIGNER | SIZE | DATE: | PART NO. | REV |
| | A | 4/28/04 | #70 | |
| APPROVED | SCALE | RELEASE DATE | WEIGHT | SHEET |

| REVISIONS | | | | |
|-----------|-----|-----------------------------------|------|----------|
| ZONE | REV | FINISHES: | DATE | APPROVED |
| | | 605, 606, 612, 613, 628, 629, 630 | | |

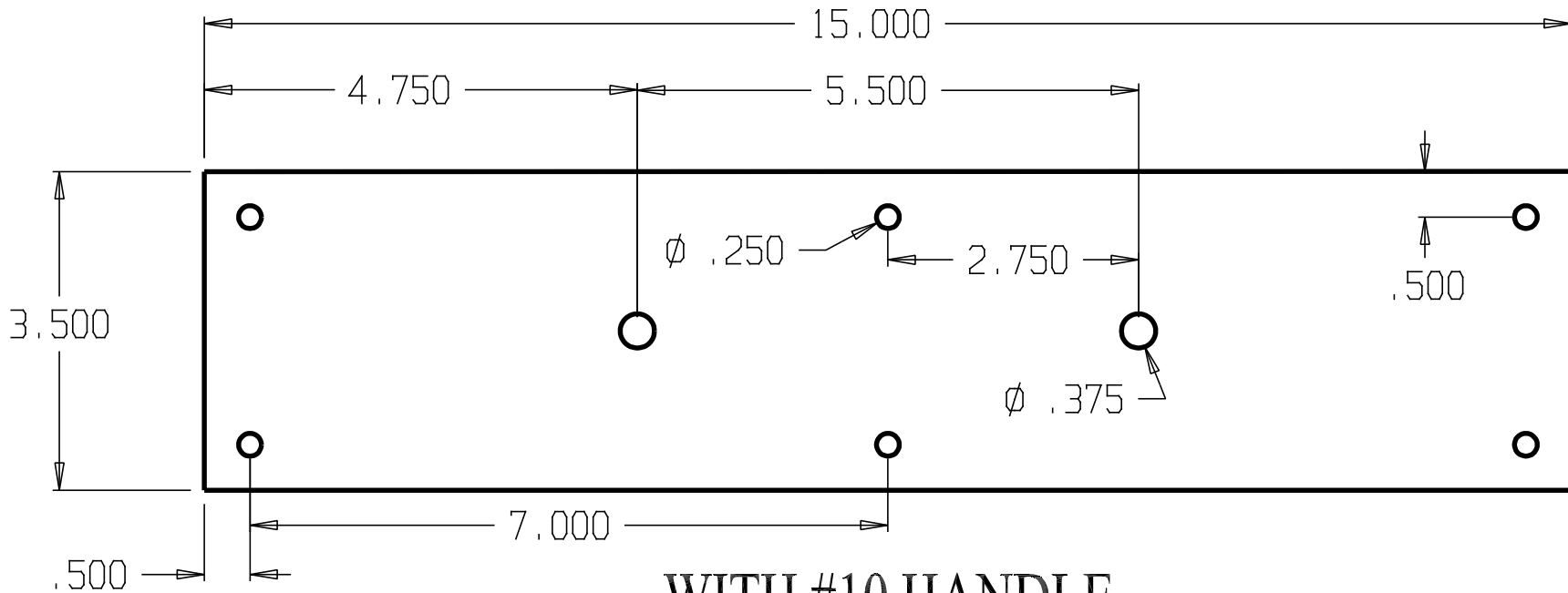

WITH #10 HANDLE

| | | | | |
|------------------|-----------|------------------|-------------------|-------|
| DON-JO MFG. INC. | | | | |
| DESIGNER | SIZE A | DATE: 4/29/04 | PART NO. #7010 | REV |
| APPROVED | SCALE | RELEASE DATE | WEIGHT | SHEET |

| REVISIONS | | | | |
|-----------|-----|-----------------------------------|------|----------|
| ZONE | REV | FINISHES: | DATE | APPROVED |
| | | 605, 606, 612, 613, 628, 629, 630 | | |

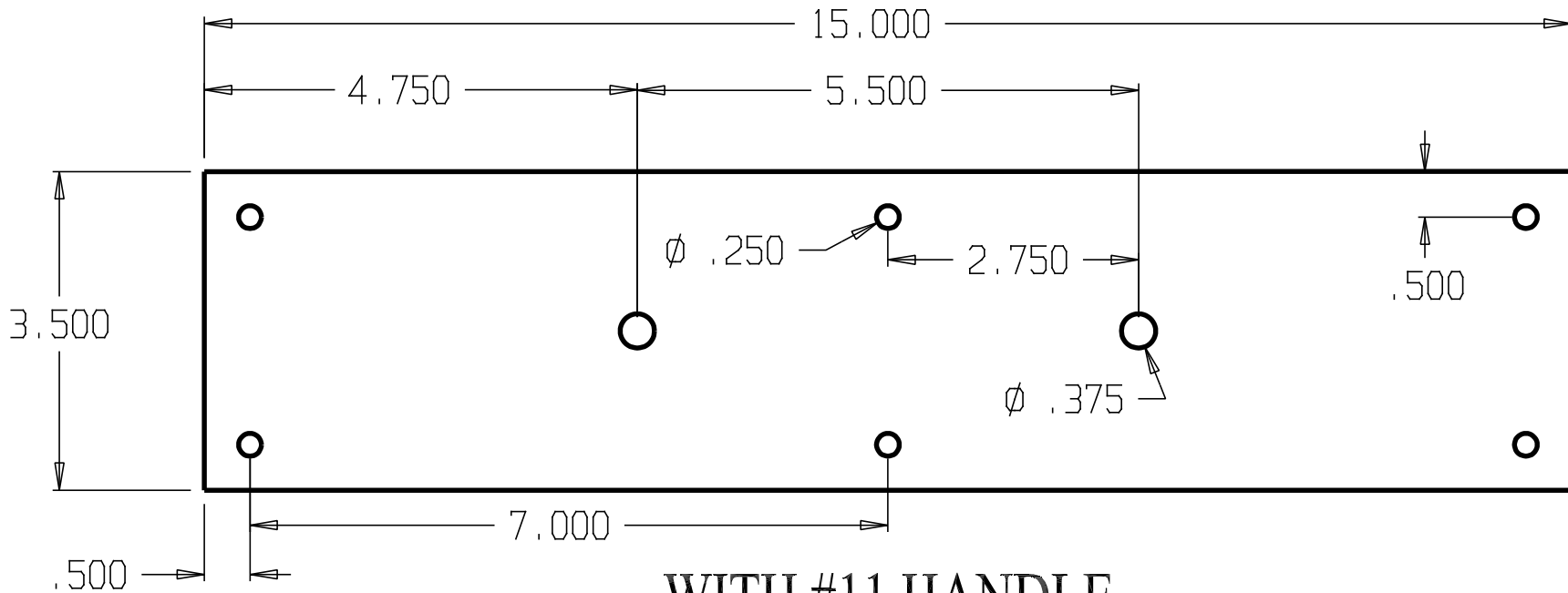

WITH #11 HANDLE

| | | | | |
|------------------|-----------|------------------|-------------------|-------|
| DON-JO MFG. INC. | | | | |
| DESIGNER | SIZE A | DATE: 4/29/04 | PART NO. #7011 | REV |
| APPROVED | SCALE | RELEASE DATE | WEIGHT | SHEET |

| REVISIONS | | | | |
|-----------|-----|-----------------------------------|------|----------|
| ZONE | REV | FINISHES: | DATE | APPROVED |
| | | 605, 606, 612, 613, 628, 629, 630 | | |

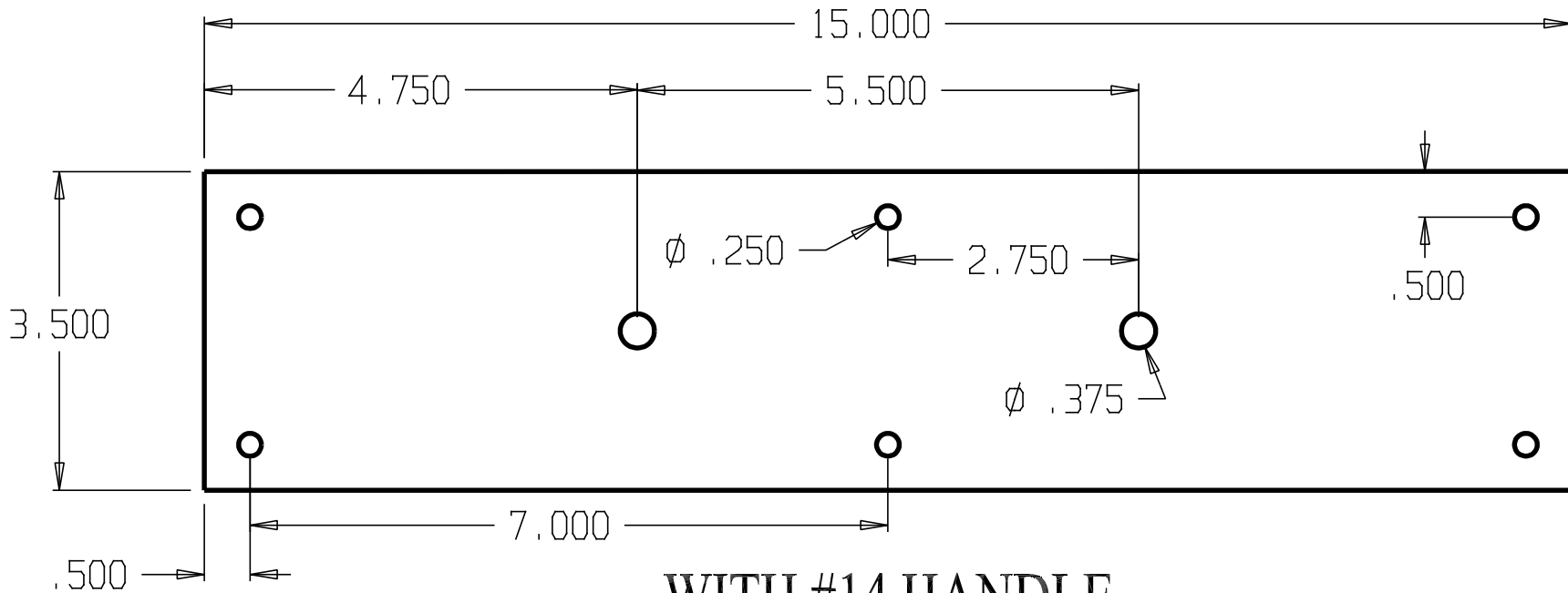

WITH #14 HANDLE

| | | | | | |
|------------------|--|-------|--------------|----------|-------|
| DON-JO MFG. INC. | | SIZE | DATE: | PART NO. | REV |
| DESIGNER | | A | 4/29/04 | #7014 | |
| APPROVED | | SCALE | RELEASE DATE | WEIGHT | SHEET |

| REVISIONS | | | | |
|-----------|-----|-----------------------------------|------|----------|
| ZONE | REV | FINISHES: | DATE | APPROVED |
| | | 605, 606, 612, 613, 628, 629, 630 | | |

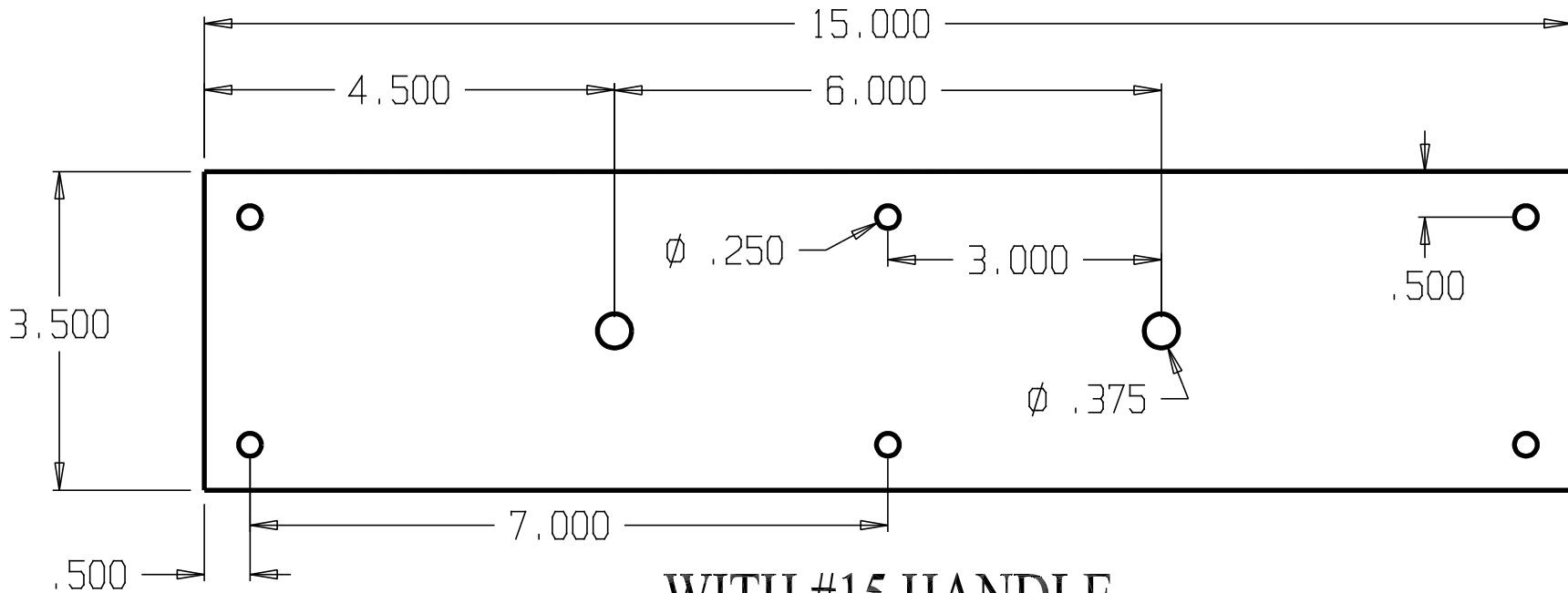

WITH #15 HANDLE

| | | | | | |
|------------------|--|-------|--------------|----------|-------|
| DON-JO MFG. INC. | | SIZE | DATE: | PART NO. | REV |
| DESIGNER | | A | 4/29/04 | #7015 | |
| APPROVED | | SCALE | RELEASE DATE | WEIGHT | SHEET |

| REVISIONS | | | | |
|-----------|-----|-----------------------------------|------|----------|
| ZONE | REV | FINISHES: | DATE | APPROVED |
| | | 605, 606, 612, 613, 628, 629, 630 | | |

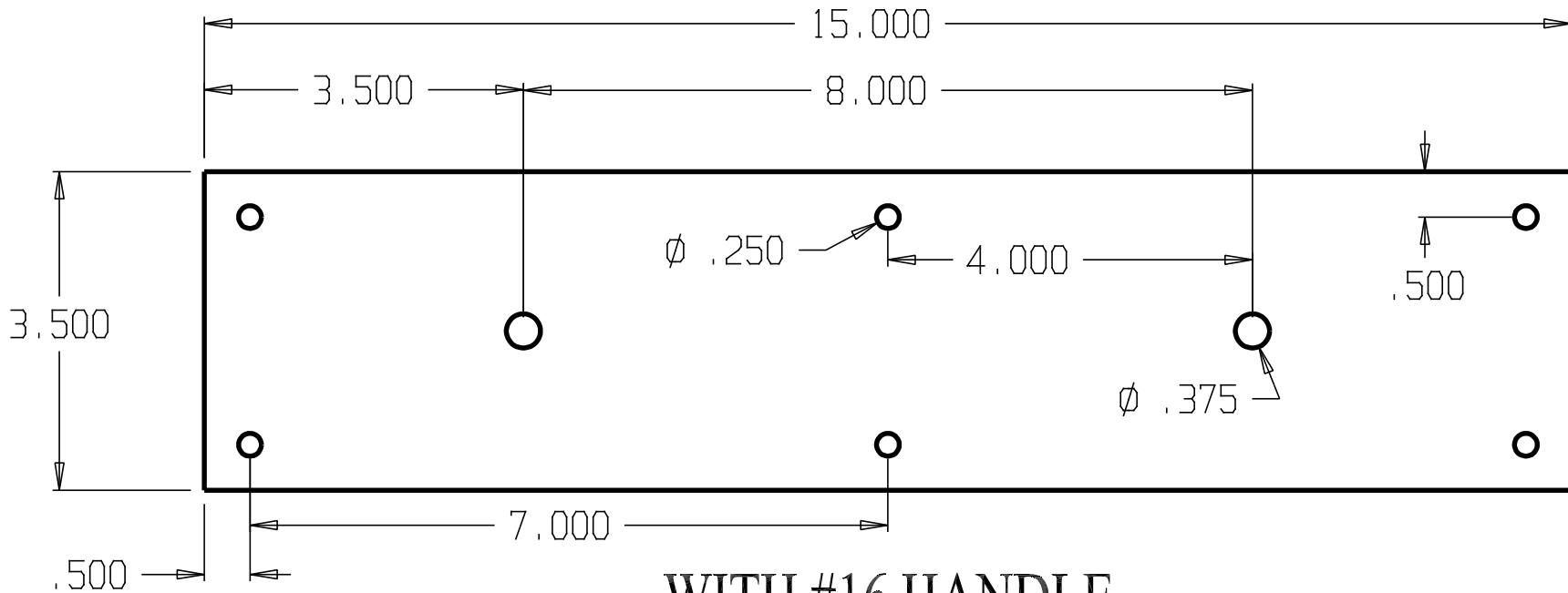

WITH #16 HANDLE

| | | | | |
|------------------|-------|--------------|----------|-------|
| DON-JO MFG. INC. | | | | |
| DESIGNER | SIZE | DATE: | PART NO. | REV |
| | A | 4/29/04 | #7016 | |
| APPROVED | SCALE | RELEASE DATE | WEIGHT | SHEET |

| REVISIONS | | | | |
|-----------|-----|-----------------------------------|------|----------|
| ZONE | REV | FINISHES: | DATE | APPROVED |
| | | 605, 606, 612, 613, 628, 629, 630 | | |

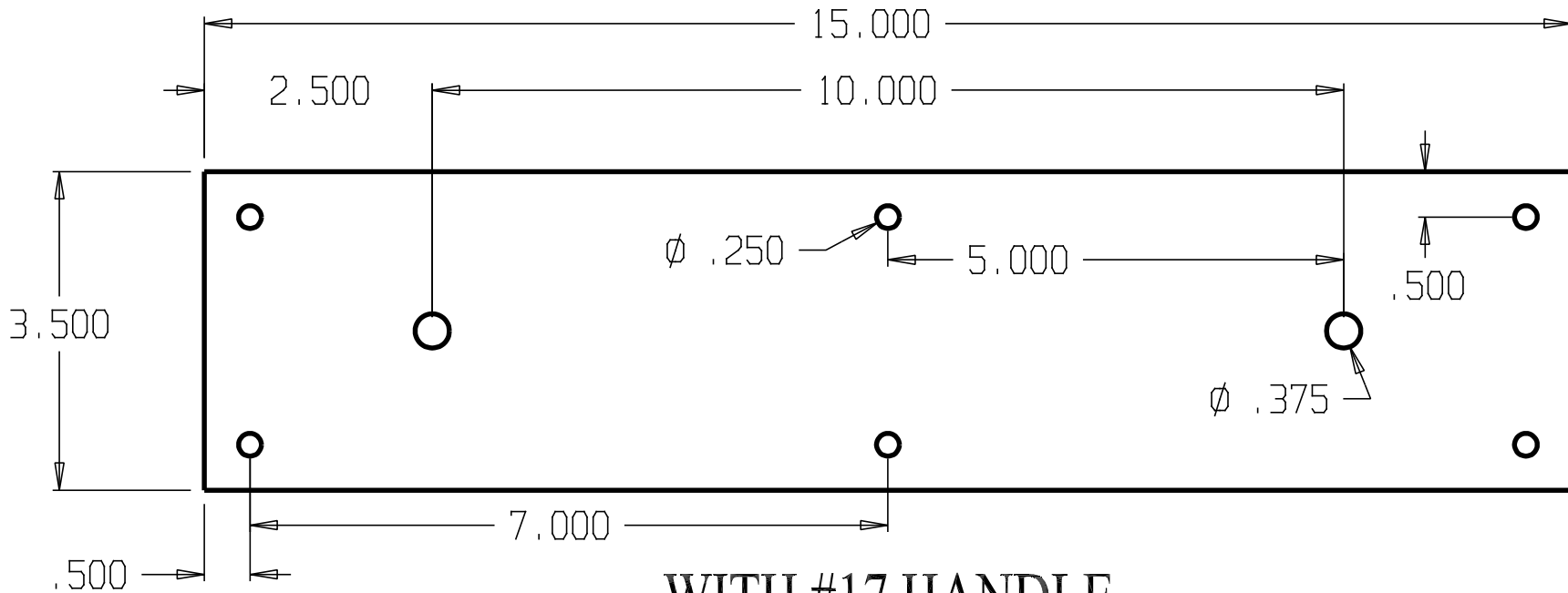

WITH #17 HANDLE

| | | | | |
|------------------|-------|--------------|----------|-------|
| DON-JO MFG. INC. | | | | |
| DESIGNER | SIZE | DATE: | PART NO. | REV |
| | A | 4/29/04 | #7017 | |
| APPROVED | SCALE | RELEASE DATE | WEIGHT | SHEET |
| | | | | |

| REVISIONS | | | | |
|-----------|-----|-----------------------------------|------|----------|
| ZONE | REV | FINISHES: | DATE | APPROVED |
| | | 605, 606, 612, 613, 628, 629, 630 | | |

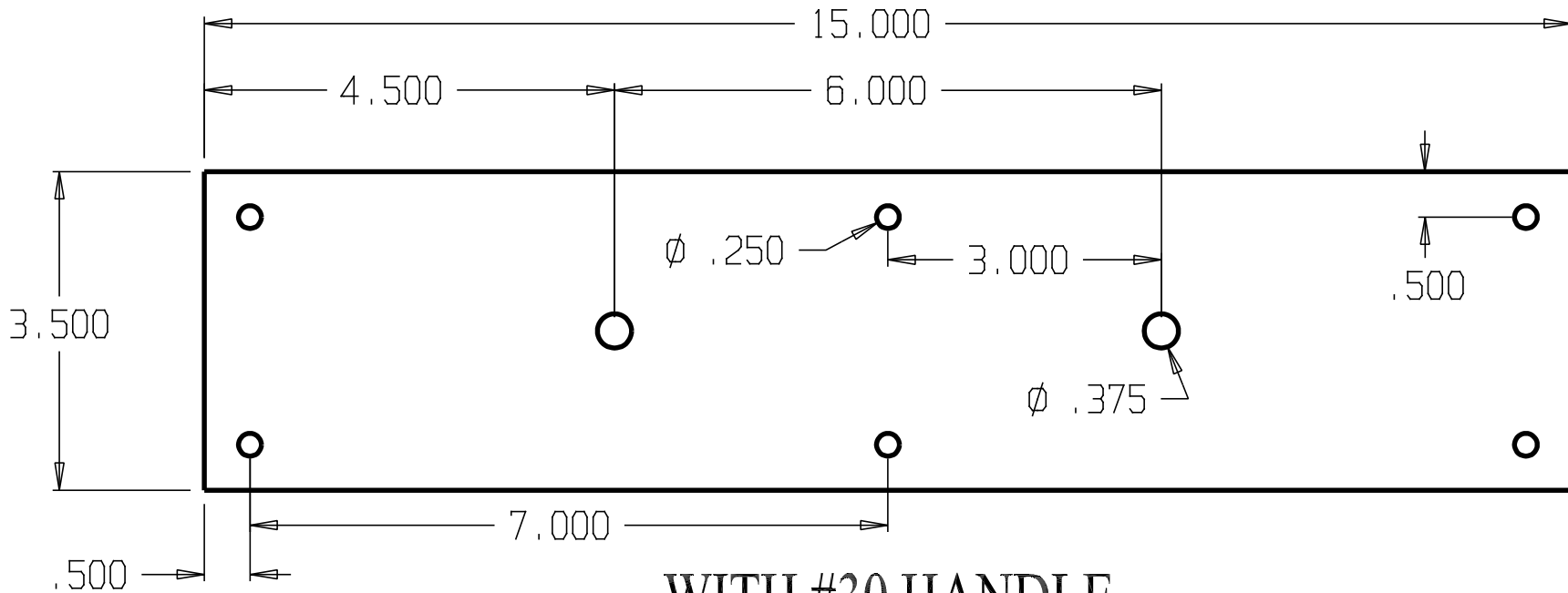

WITH #30 HANDLE

| | | | | |
|------------------|-------|--------------|----------|-------|
| DON-JO MFG. INC. | | | | |
| DESIGNER | SIZE | DATE: | PART NO. | REV |
| | A | 4/29/04 | #7030 | |
| APPROVED | SCALE | RELEASE DATE | WEIGHT | SHEET |

| REVISIONS | | | | |
|-----------|-----|-----------------------------------|------|----------|
| ZONE | REV | FINISHES: | DATE | APPROVED |
| | | 605, 606, 612, 613, 628, 629, 630 | | |

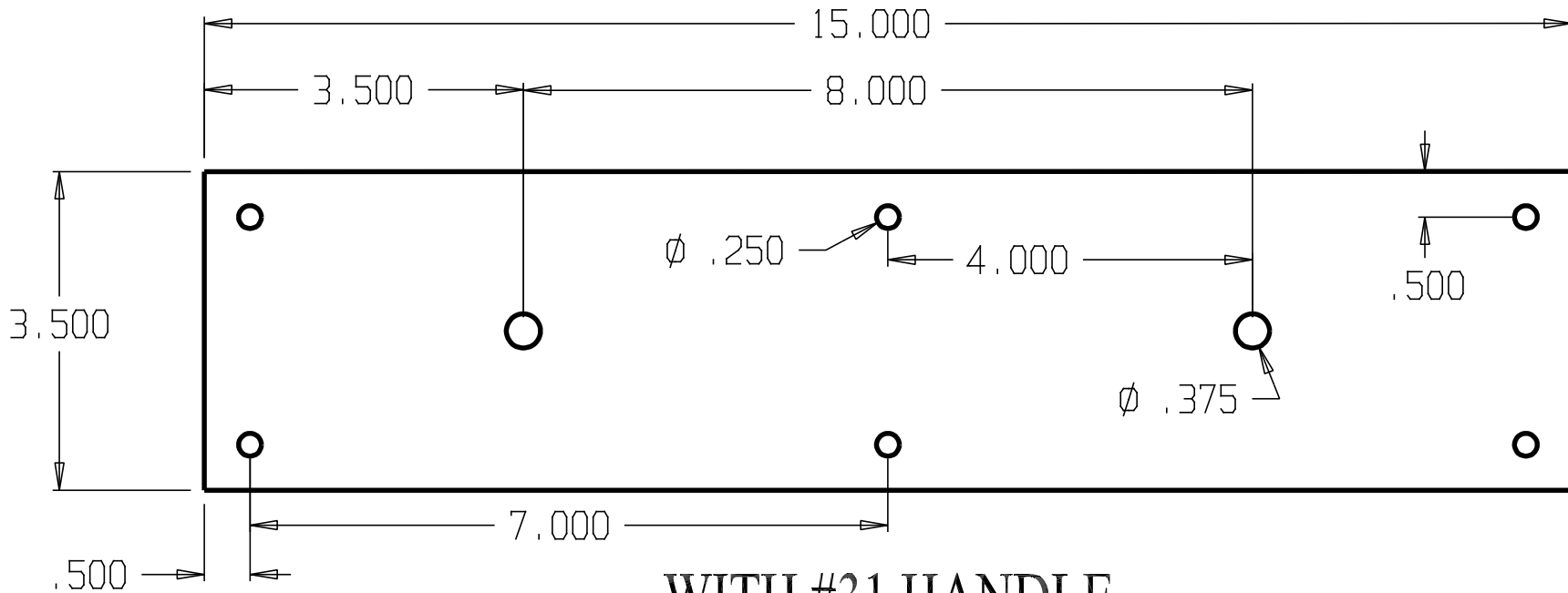

WITH #31 HANDLE

| | | | | |
|------------------|-------|--------------|----------|-------|
| DON-JO MFG. INC. | | | | |
| DESIGNER | SIZE | DATE: | PART NO. | REV |
| | A | 4/29/04 | #7031 | |
| APPROVED | SCALE | RELEASE DATE | WEIGHT | SHEET |

| REVISIONS | | | | |
|-----------|-----|---|------|----------|
| ZONE | REV | FINISHES: | DATE | APPROVED |
| | | 605,606,609,612,613,619, 620,626,628,629,630 | | |

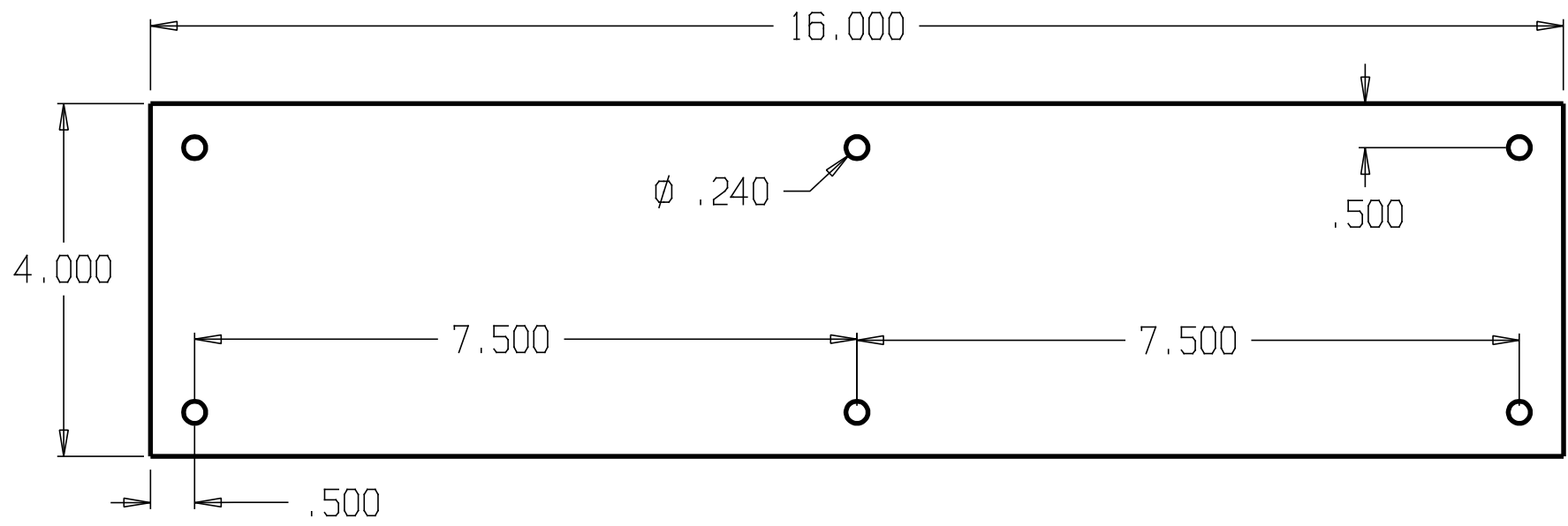

DON-JO MFG. INC.

| | |
|----------|--|
| DESIGNER | |
| APPROVED | |

| | | | |
|-------|--------------|----------|-------|
| SIZE | DATE: | PART NO. | REV |
| A | 4/28/04 | #71 | |
| SCALE | RELEASE DATE | WEIGHT | SHEET |

| REVISIONS | | | | |
|-----------|-----|-----------------------------------|------|----------|
| ZONE | REV | FINISHES: | DATE | APPROVED |
| | | 605, 606, 612, 613, 628, 629, 630 | | |

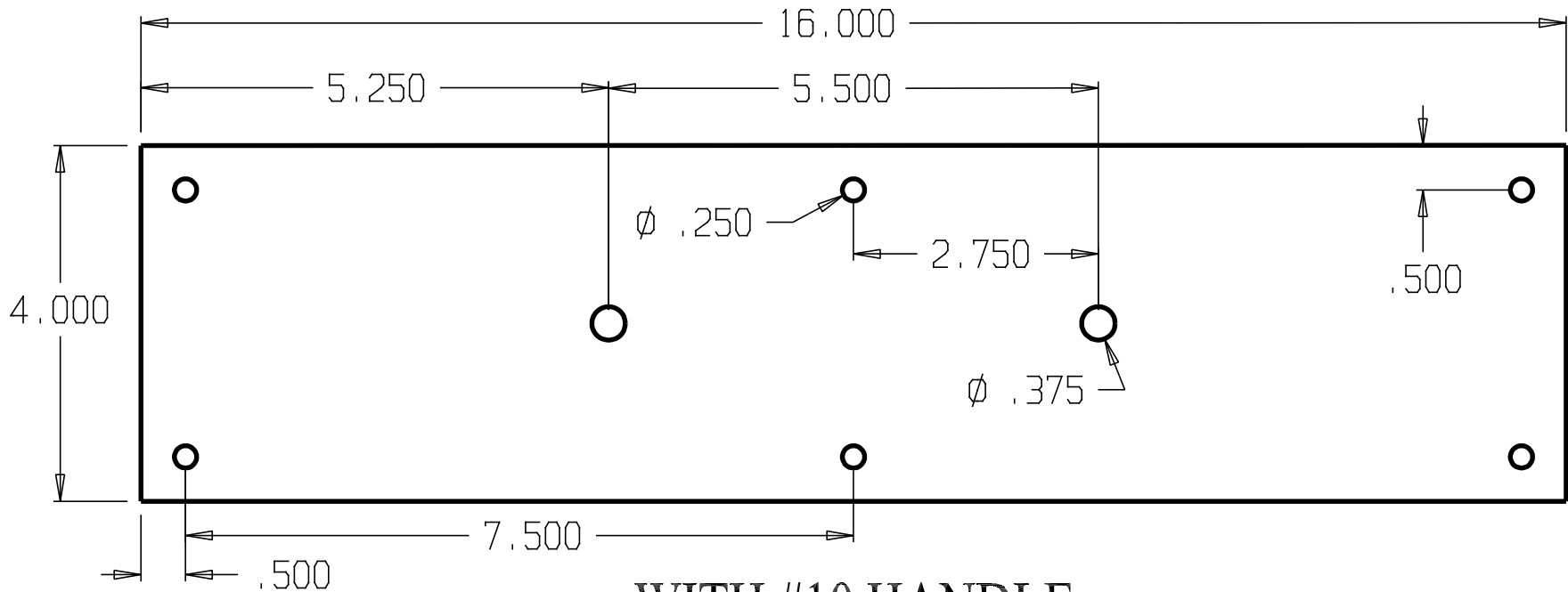

WITH #10 HANDLE

| | | | | |
|------------------|-------|--------------|----------|-------|
| DON-JO MFG. INC. | | | | |
| DESIGNER | SIZE | DATE: | PART NO. | REV |
| | A | 4/29/04 | #7110 | |
| APPROVED | SCALE | RELEASE DATE | WEIGHT | SHEET |

| REVISIONS | | | | |
|-----------|-----|-----------------------------------|------|----------|
| ZONE | REV | FINISHES: | DATE | APPROVED |
| | | 605, 606, 612, 613, 628, 629, 630 | | |

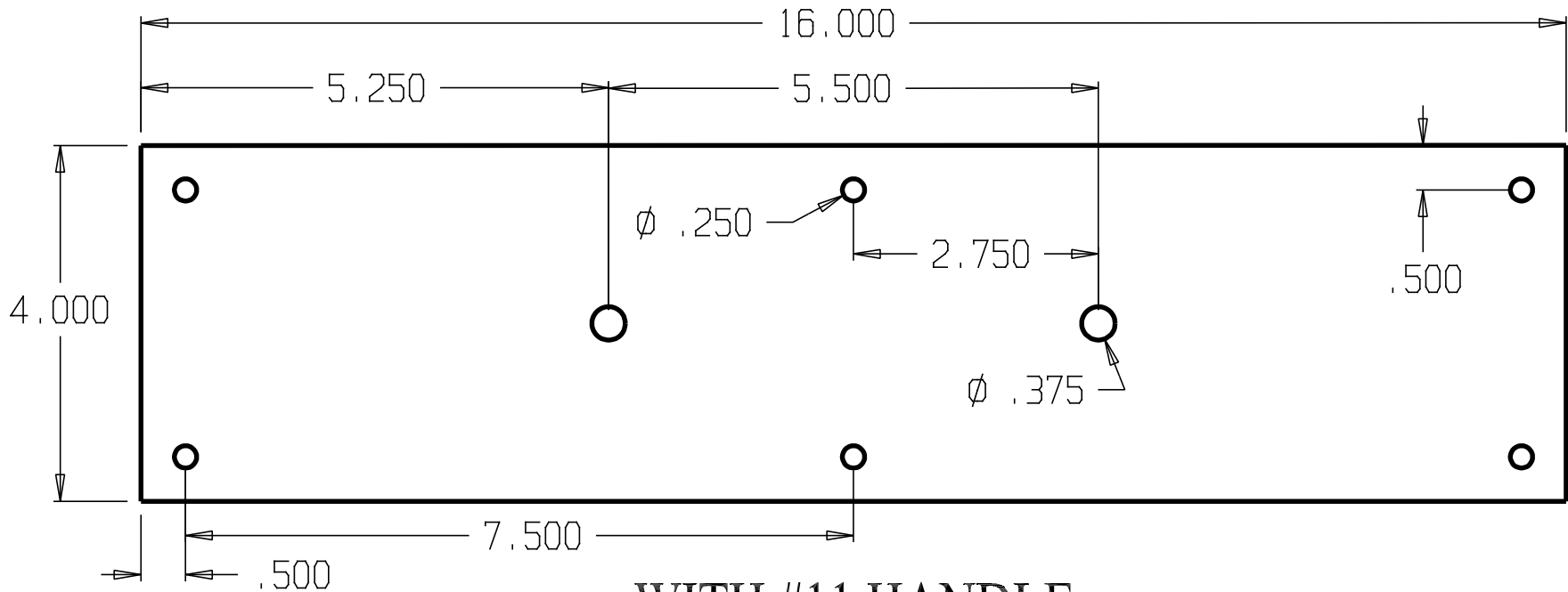

WITH #11 HANDLE

| | | | | |
|------------------|---------|---------------|----------------|-------|
| DON-JO MFG. INC. | | | | |
| DESIGNER | SIZE: A | DATE: 4/29/04 | PART NO. #7111 | REV |
| APPROVED | SCALE | RELEASE DATE | WEIGHT | SHEET |

| REVISIONS | | | | |
|-----------|-----|-----------------------------------|------|----------|
| ZONE | REV | FINISHES: | DATE | APPROVED |
| | | 605, 606, 612, 613, 628, 629, 630 | | |

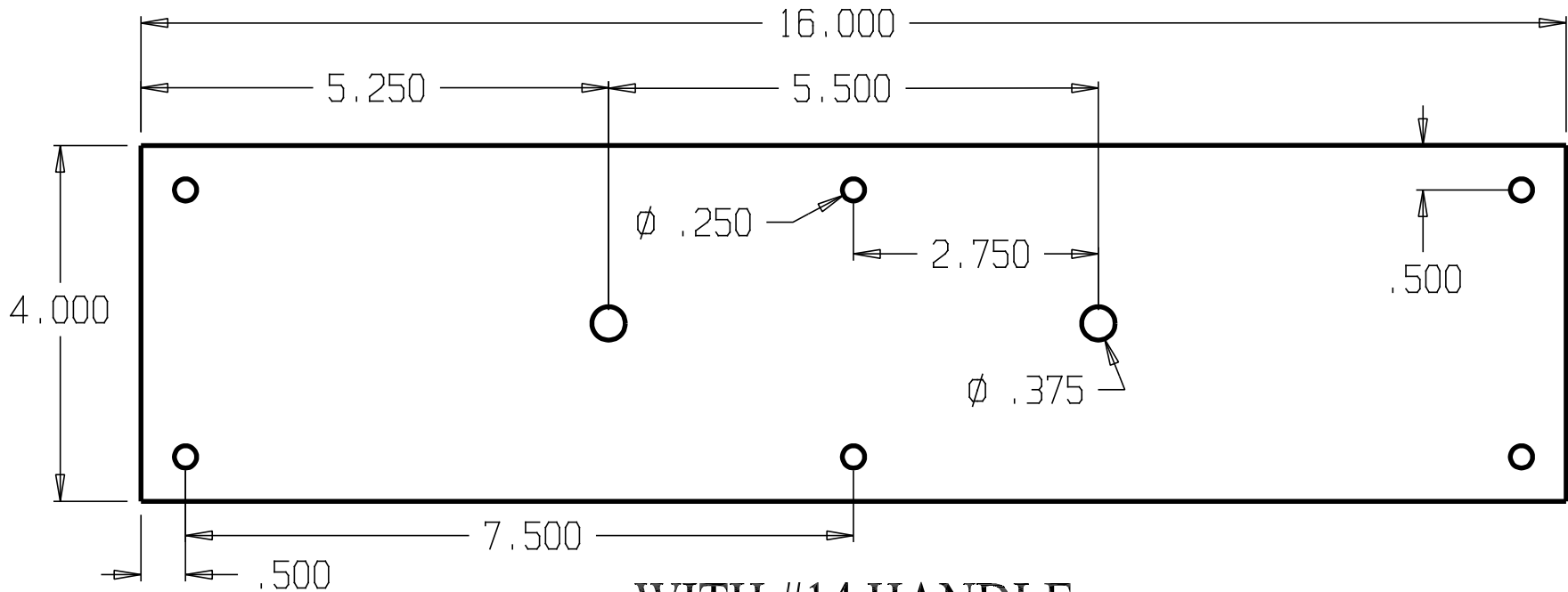

WITH #14 HANDLE

| | | | | |
|------------------|-------|--------------|----------|-------|
| DON-JO MFG. INC. | | | | |
| DESIGNER | SIZE | DATE: | PART NO. | REV |
| | A | 4/29/04 | #7114 | |
| APPROVED | SCALE | RELEASE DATE | WEIGHT | SHEET |

| REVISIONS | | | | |
|-----------|-----|-----------------------------------|------|----------|
| ZONE | REV | FINISHES: | DATE | APPROVED |
| | | 605, 606, 612, 613, 628, 629, 630 | | |

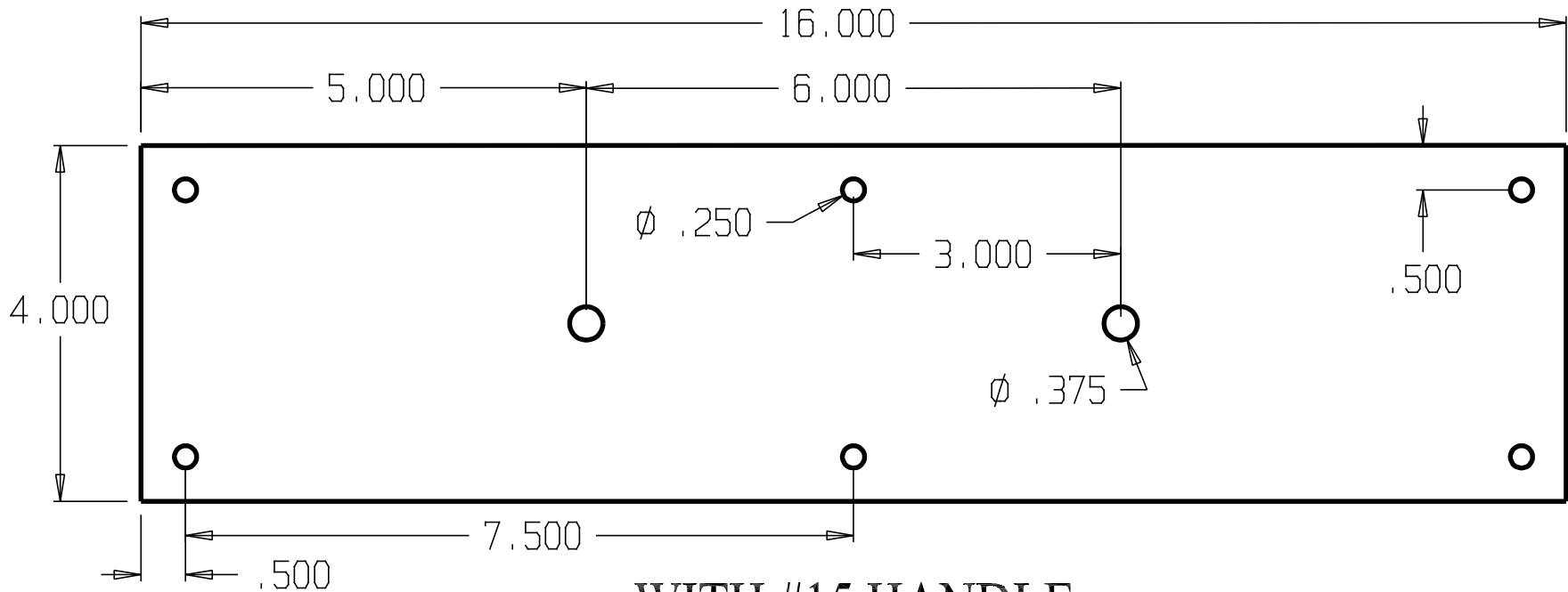

WITH #15 HANDLE

| | | | | | |
|------------------|--|-------|--------------|----------|-------|
| DON-JO MFG. INC. | | SIZE | DATE: | PART NO. | REV |
| DESIGNER | | A | 4/29/04 | #7115 | |
| APPROVED | | SCALE | RELEASE DATE | WEIGHT | SHEET |

| REVISIONS | | | | |
|-----------|-----|-----------------------------------|------|----------|
| ZONE | REV | FINISHES: | DATE | APPROVED |
| | | 605, 606, 612, 613, 628, 629, 630 | | |

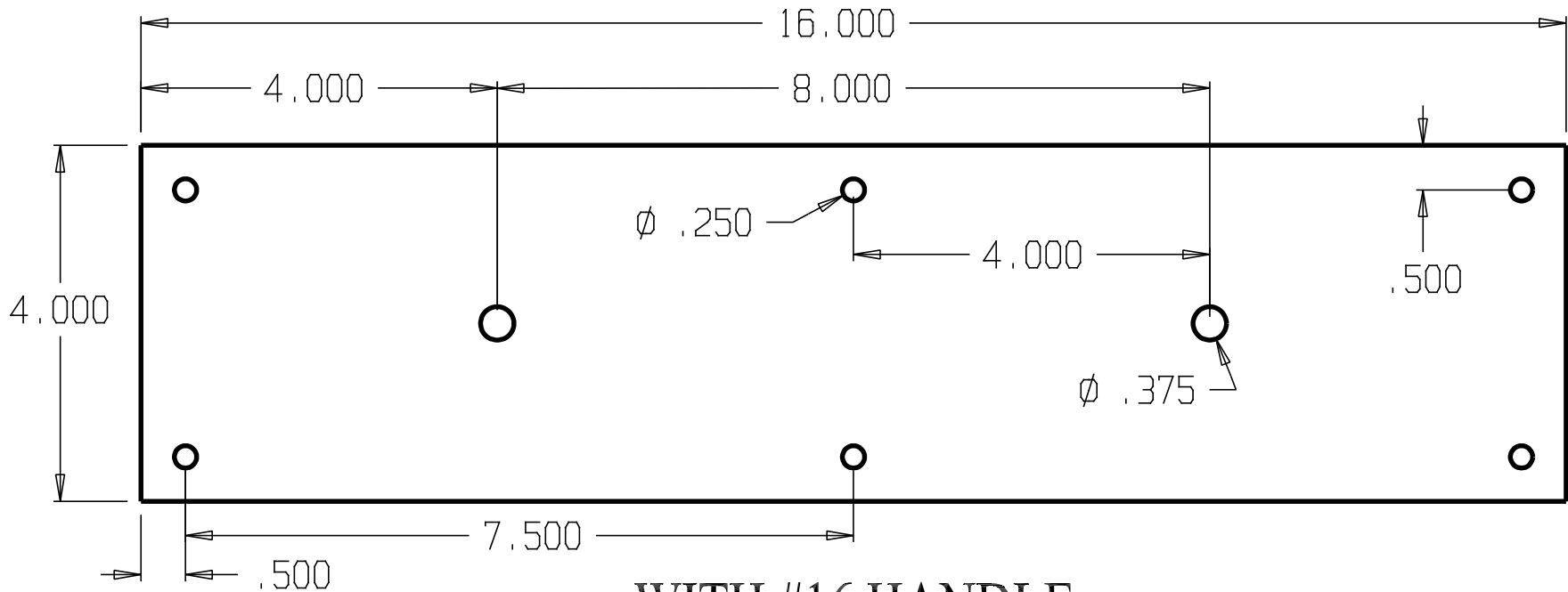

WITH #16 HANDLE

| | | | | | |
|------------------|--|-------|--------------|----------|-------|
| DON-JO MFG. INC. | | SIZE | DATE: | PART NO. | REV |
| DESIGNER | | A | 4/29/04 | #7116 | |
| APPROVED | | SCALE | RELEASE DATE | WEIGHT | SHEET |

| REVISIONS | | | | |
|-----------|-----|-----------------------------------|------|----------|
| ZONE | REV | FINISHES: | DATE | APPROVED |
| | | 605, 606, 612, 613, 628, 629, 630 | | |

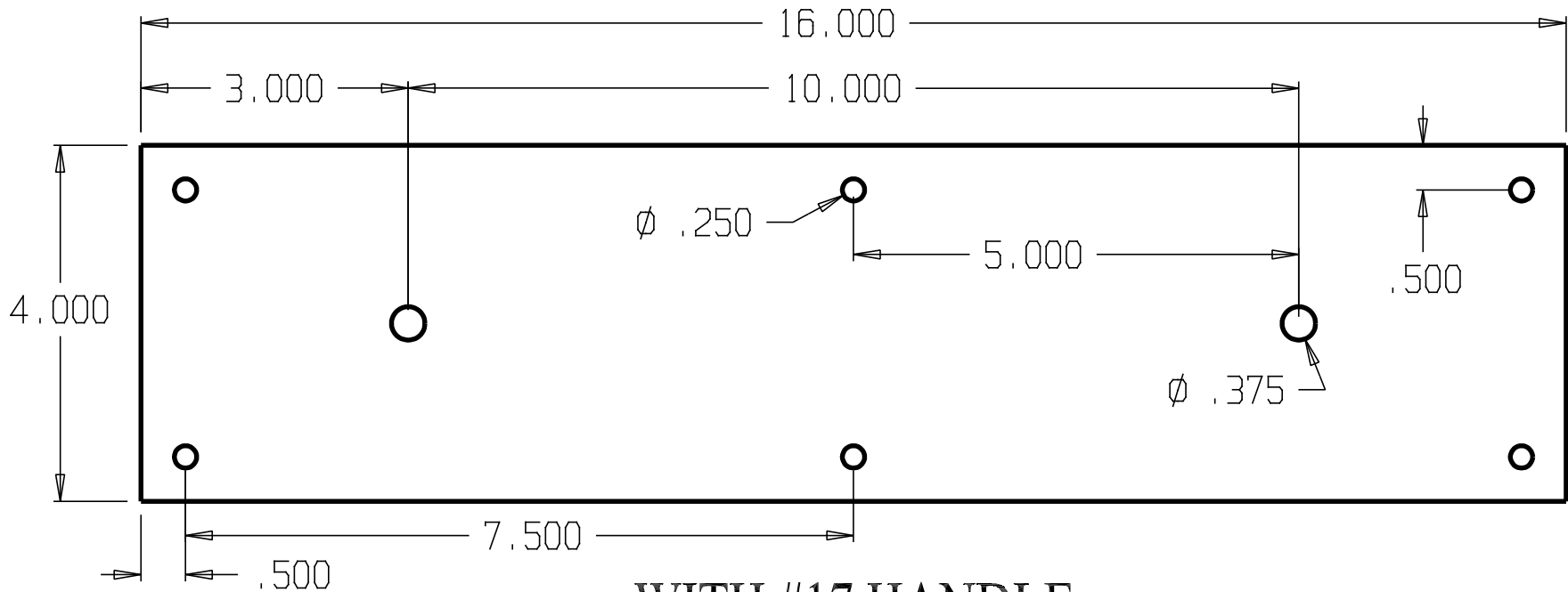

WITH #17 HANDLE

| | | | | |
|------------------|-------|--------------|----------|-------|
| DON-JO MFG. INC. | | | | |
| DESIGNER | SIZE | DATE: | PART NO. | REV |
| | A | 4/29/04 | #7117 | |
| APPROVED | SCALE | RELEASE DATE | WEIGHT | SHEET |

| REVISIONS | | | | |
|-----------|-----|-----------------------------------|------|----------|
| ZONE | REV | FINISHES: | DATE | APPROVED |
| | | 605, 606, 612, 613, 628, 629, 630 | | |

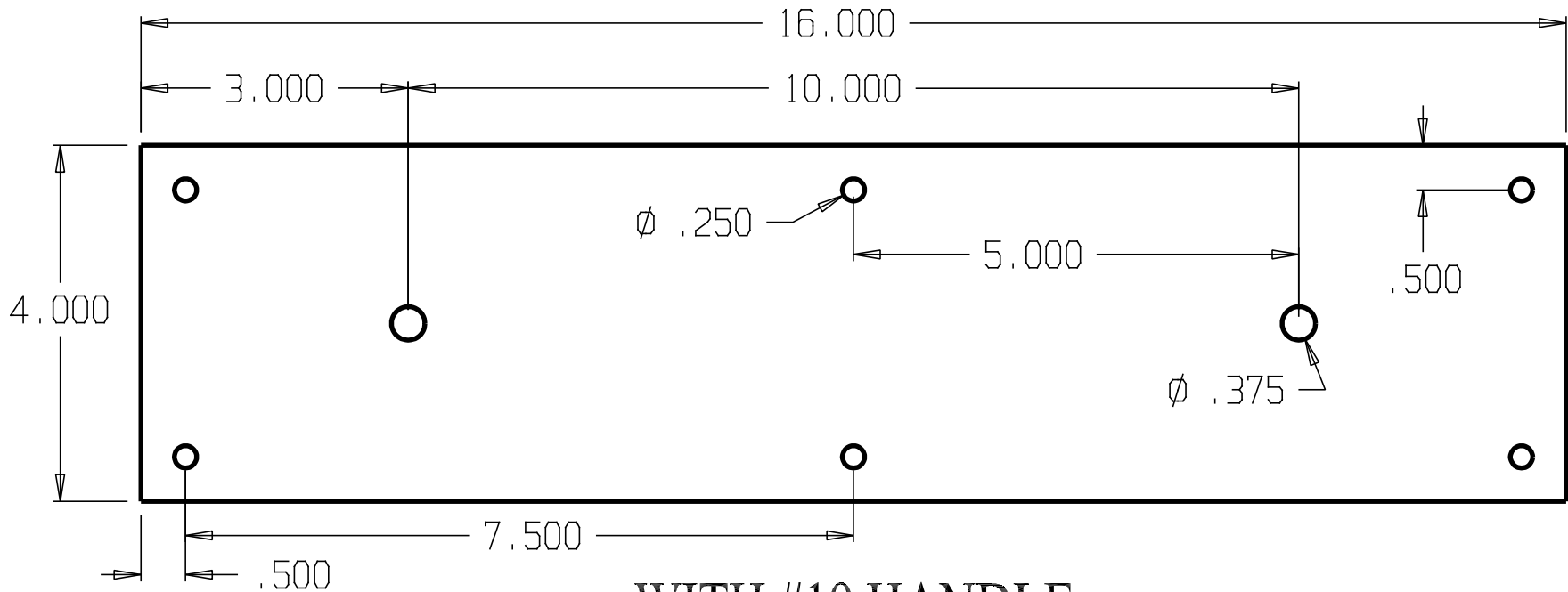

WITH #19 HANDLE

| | | | | | |
|------------------|--|-------|--------------|----------|-------|
| DON-JO MFG. INC. | | SIZE | DATE: | PART NO. | REV |
| DESIGNER | | A | 4/29/04 | #7119 | |
| APPROVED | | SCALE | RELEASE DATE | WEIGHT | SHEET |

| REVISIONS | | | | |
|-----------|-----|-----------------------------|------|----------|
| ZONE | REV | FINISHES : | DATE | APPROVED |
| | | 605,606,612,613,628,629,630 | | |

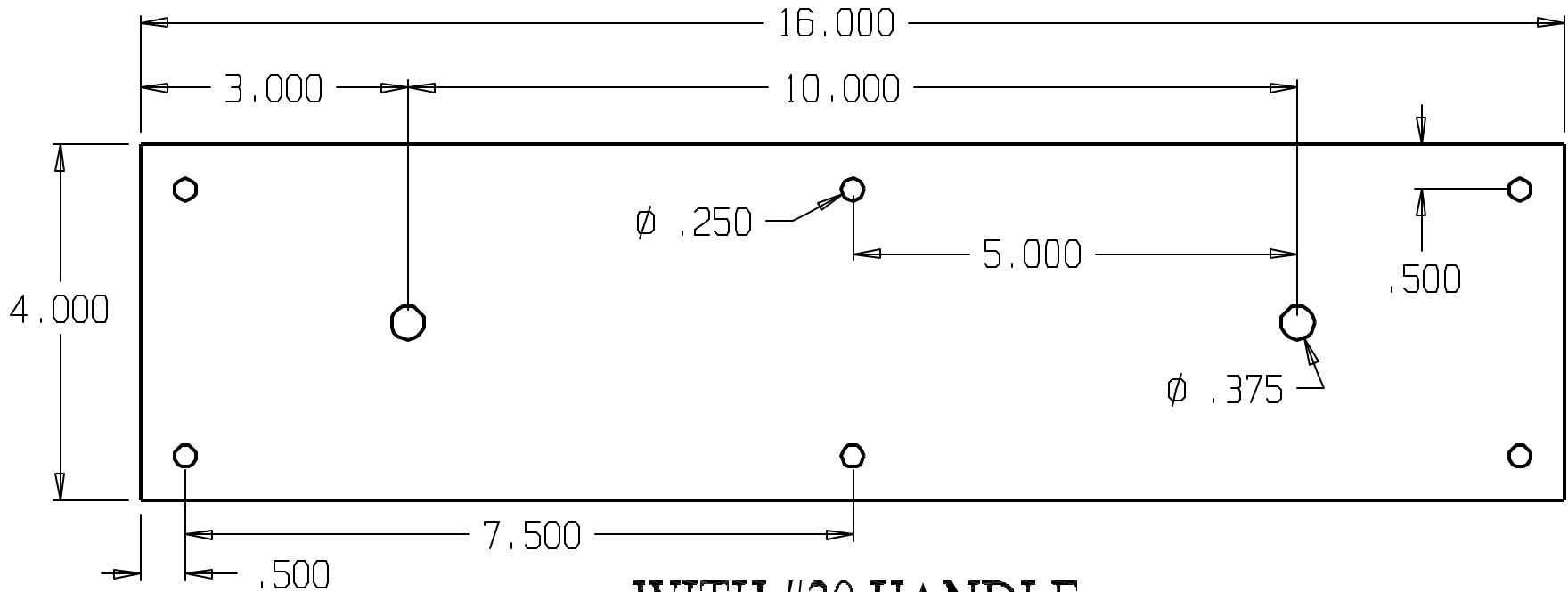

WITH #20 HANDLE

| | | | | | |
|------------------|--|-------|--------------|----------|-------|
| DON-JO MFG. INC. | | SIZE | DATE | PART NO. | REV |
| DESIGNER | | A | 4/29/04 | #7120 | |
| APPROVED | | SCALE | RELEASE DATE | WEIGHT | SHEET |

| REVISIONS | | | | |
|-----------|-----|-----------------------------------|------|----------|
| ZONE | REV | FINISHES: | DATE | APPROVED |
| | | 605, 606, 612, 613, 628, 629, 630 | | |

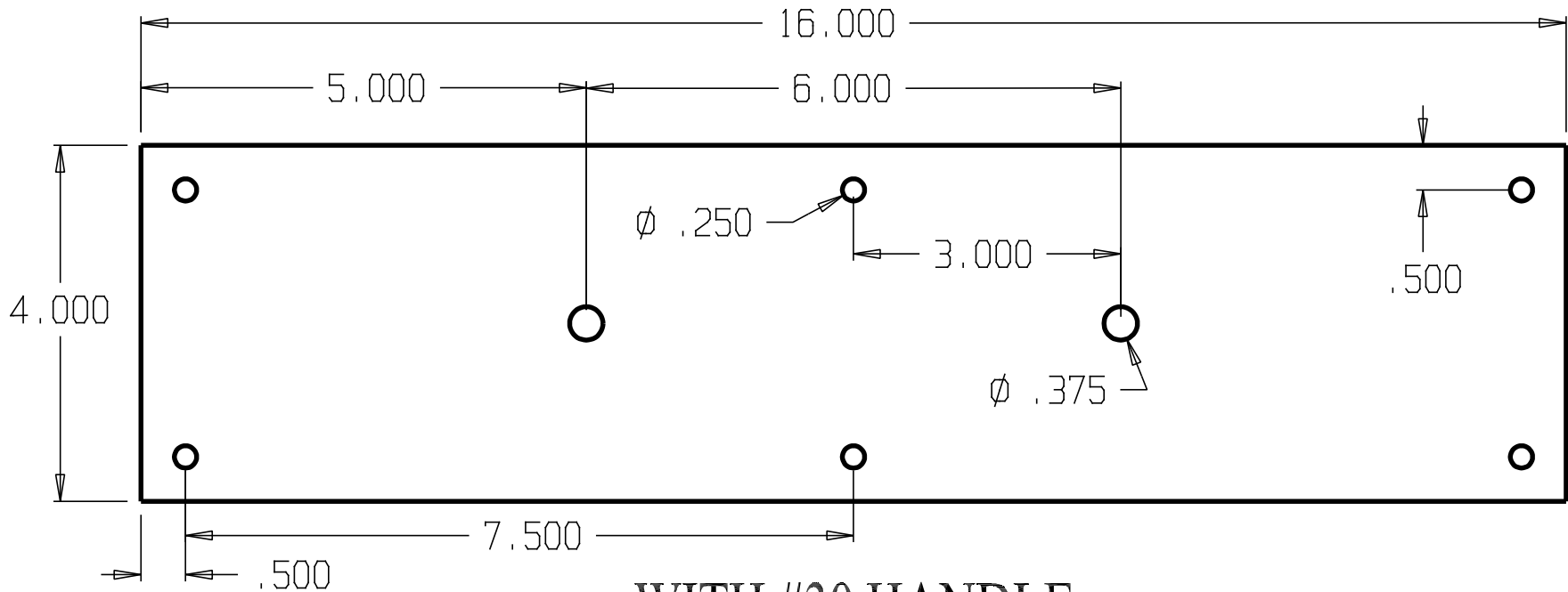

WITH #30 HANDLE

| | | | | | |
|------------------|--|-------|--------------|----------|-------|
| DON-JO MFG. INC. | | SIZE | DATE: | PART NO. | REV |
| DESIGNER | | A | 4/29/04 | #7130 | |
| APPROVED | | SCALE | RELEASE DATE | WEIGHT | SHEET |

| REVISIONS | | | | |
|-----------|-----|------------|------|----------|
| ZONE | REV | FINISHES : | DATE | APPROVED |
| | | 630 | | |

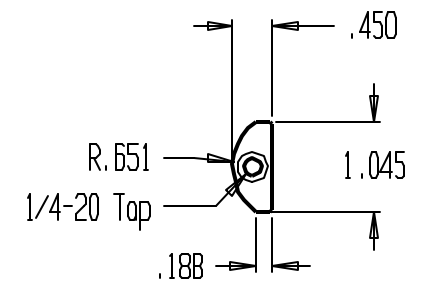
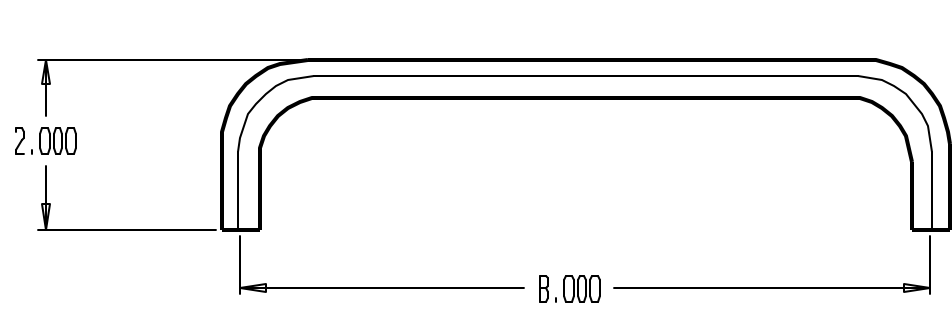
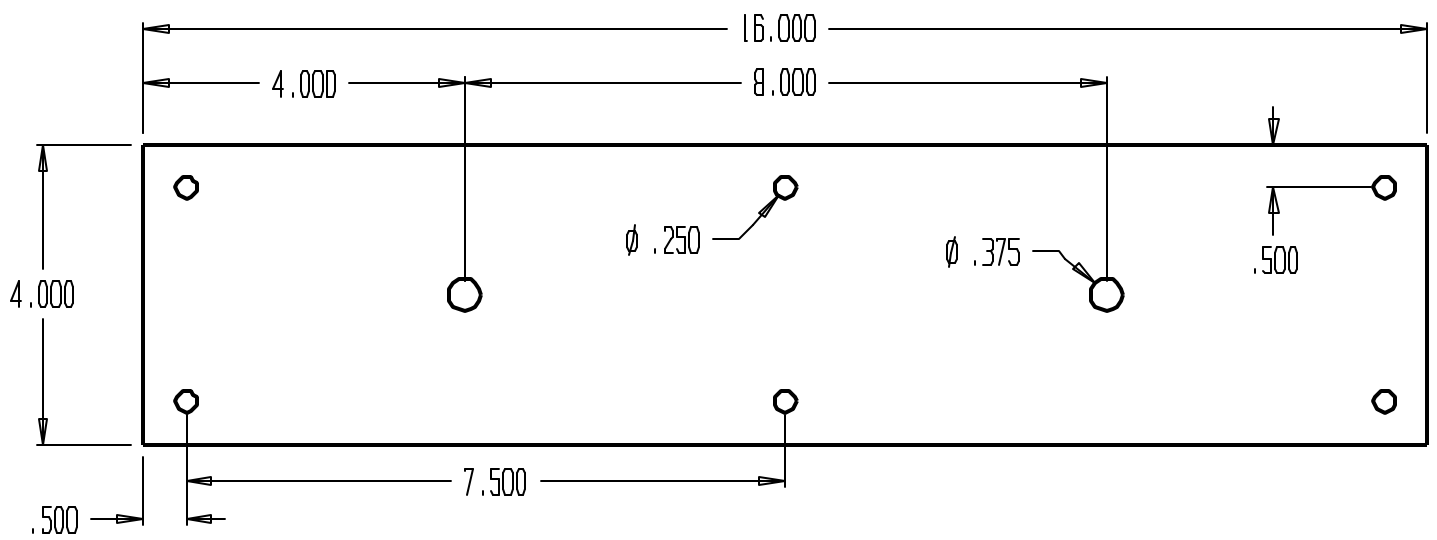

DON-JO MFG. INC.

| | | | | |
|----------|-----------|-----------------|-------------------|-------|
| DESIGNER | SIZE A | DATE 4/16/04 | PART NO. #7138 | REV |
| APPROVED | SCALE | RELEASE DATE | WEIGHT | SHEET |

| REVISIONS | | | | |
|-----------|-----|---|------|----------|
| ZONE | REV | FINISHES: | DATE | APPROVED |
| | | 605,606,609,612,613,619, 620,626,628,629,630 | | |

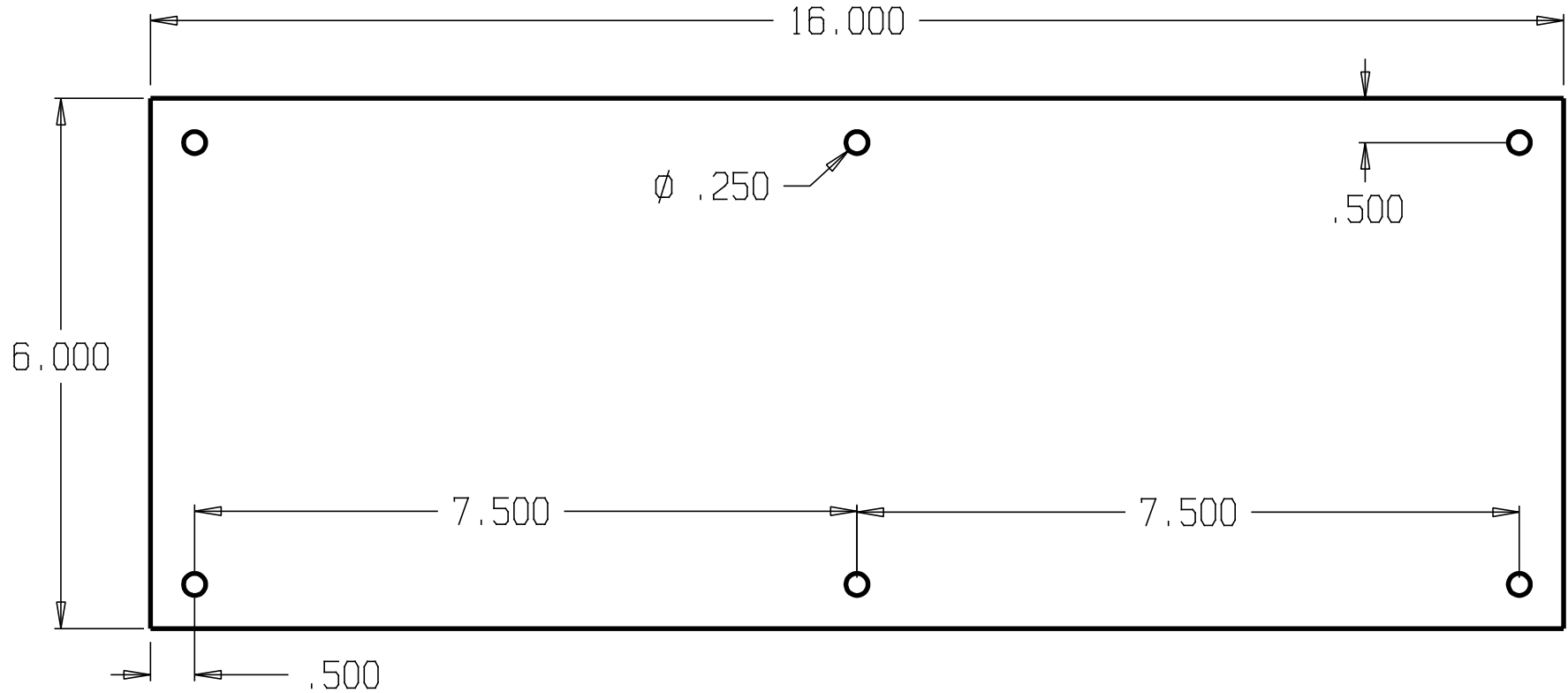

DON-JO MFG. INC.

| | | | | |
|----------|-------|--------------|----------|-------|
| DESIGNER | SIZE | DATE: | PART NO. | REV |
| | A | 4/28/04 | #72 | |
| APPROVED | SCALE | RELEASE DATE | WEIGHT | SHEET |
| | | | | |

| REVISIONS | | | | |
|-----------|-----|--|------|----------|
| ZONE | REV | FINISHES: | DATE | APPROVED |
| | | 605, 606, 609, 612, 613, 619, 620, 626, 628, 629, 630 | | |

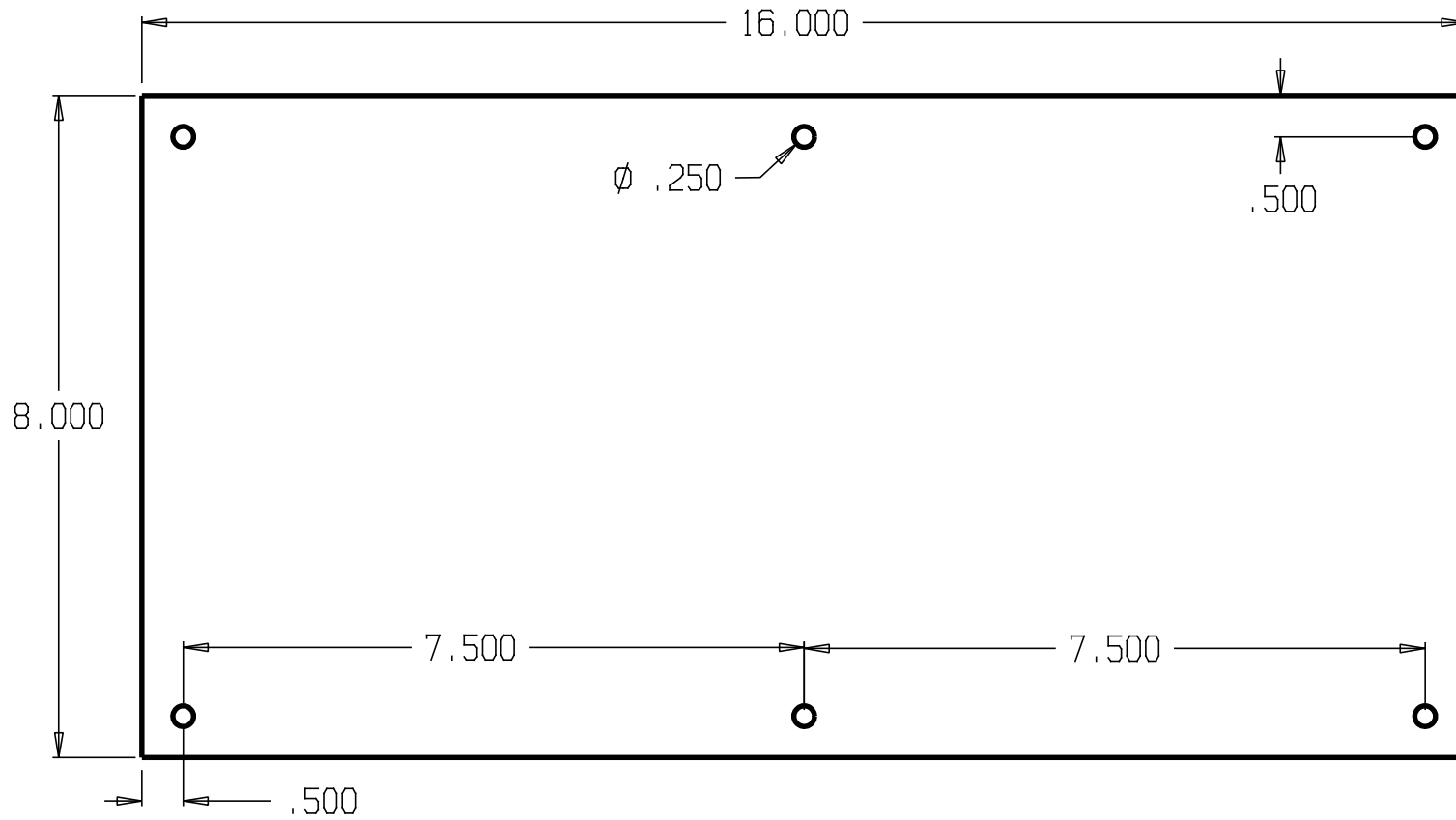

DON-JO MFG. INC.

| | |
|----------|--|
| DESIGNER | |
| APPROVED | |

| | | | |
|-------|--------------|----------|-------|
| SIZE | DATE: | PART NO. | REV |
| A | 4/28/04 | #73 | |
| SCALE | RELEASE DATE | WEIGHT | SHEET |

| REVISIONS | | | | |
|-----------|-----|---|------|----------|
| ZONE | REV | FINISHES : | DATE | APPROVED |
| | | 605,606,609,612,613,619, 620,626,628,629,630 | | |

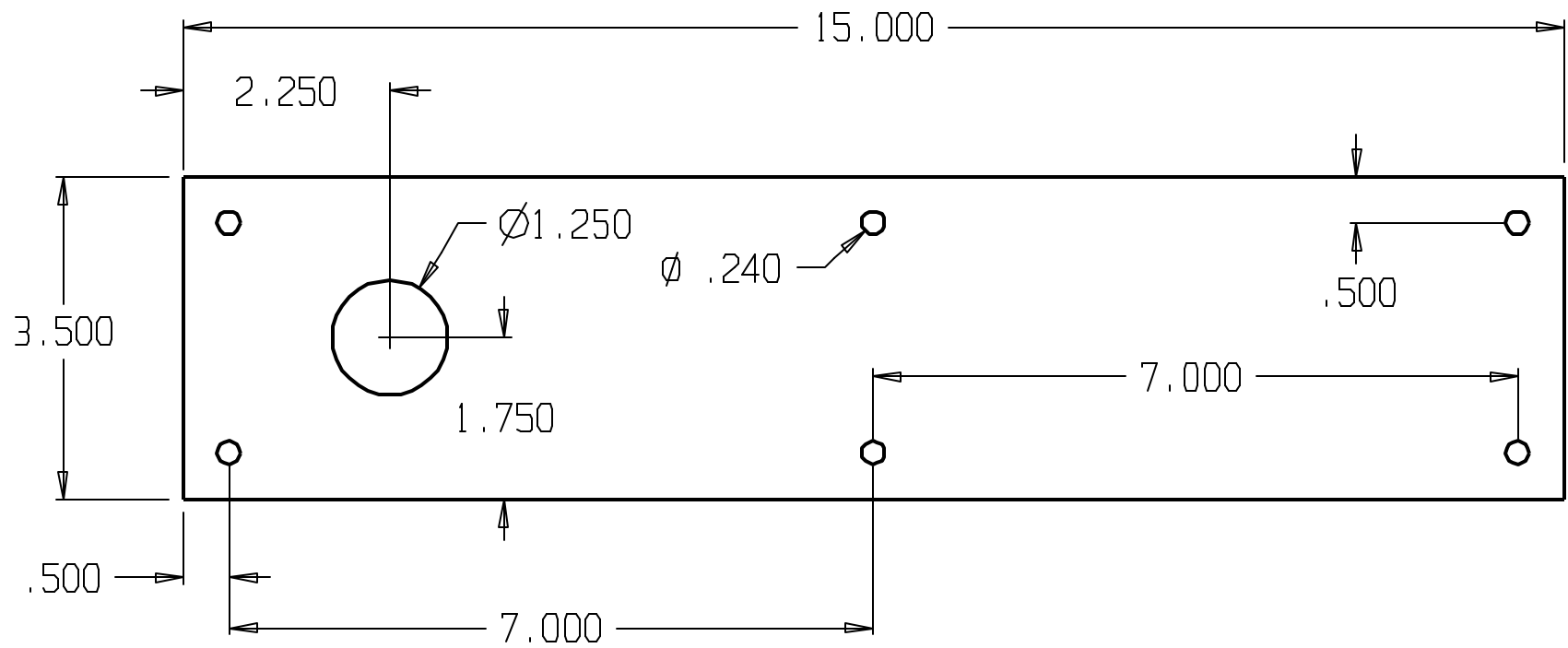

DON-JO MFG. INC.

| | | | | |
|----------|-------|--------------|----------|-------|
| DESIGNER | SIZE | DATE | PART NO. | REV |
| | A | 4/28/04 | #70 CFC | |
| APPROVED | SCALE | RELEASE DATE | WEIGHT | SHEET |

| REVISIONS | | | | |
|-----------|-----|-----------------------------|------|----------|
| ZONE | REV | FINISHES: | DATE | APPROVED |
| | | 605,606,612,613,628,629,630 | | |

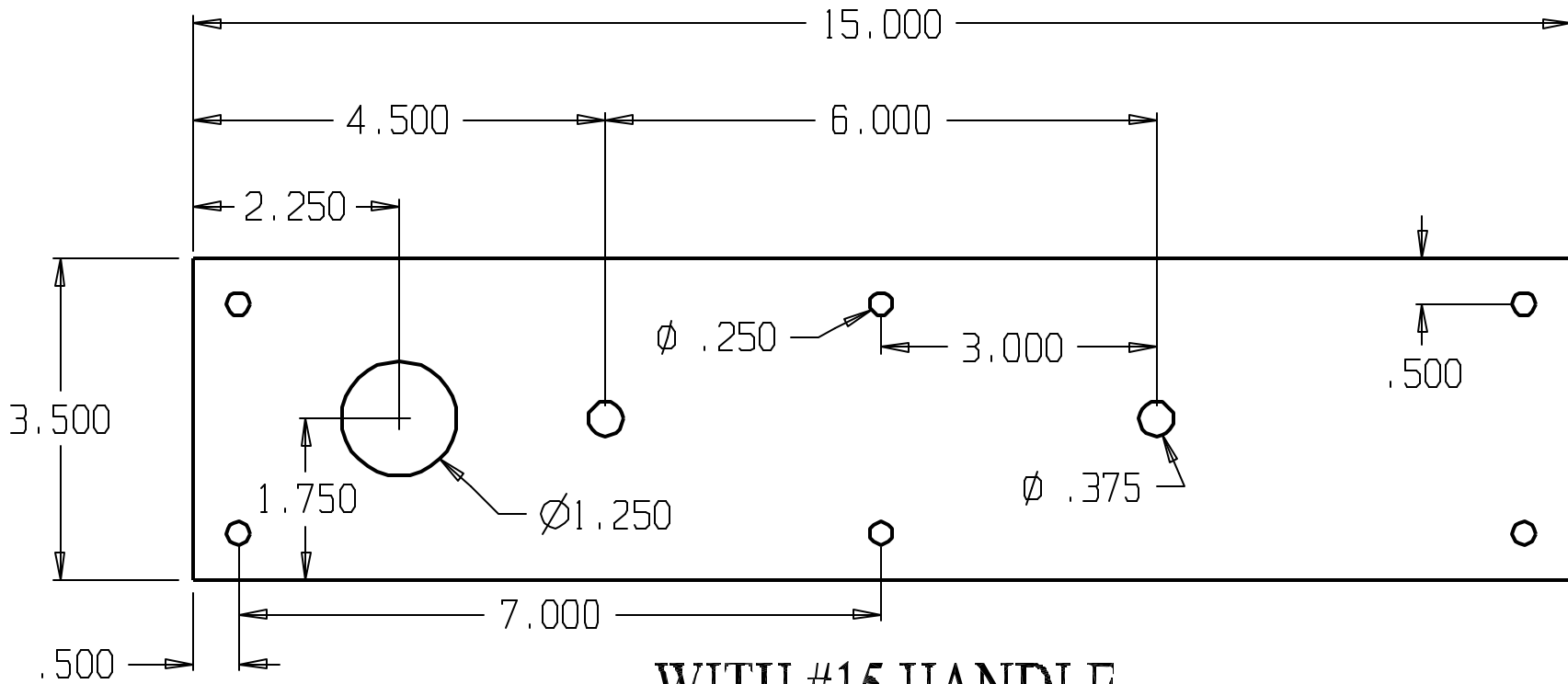

WITH #15 HANDLE

| | | | | | |
|------------------|--|-------|--------------|-----------|-------|
| DON-JO MFG. INC. | | SIZE | DATE | PART NO. | REV |
| DESIGNER | | A | 4/29/04 | #7015 CFC | |
| APPROVED | | SCALE | RELEASE DATE | WEIGHT | SHEET |

| REVISIONS | | | | |
|-----------|-----|-----------------------------------|------|----------|
| ZONE | REV | FINISHES: | DATE | APPROVED |
| | | 605, 606, 612, 613, 628, 629, 630 | | |

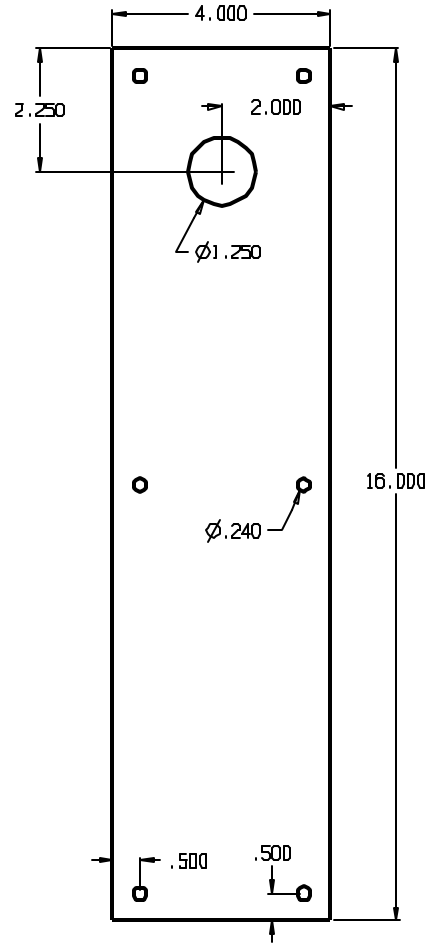

DON-JO MFG. INC.

| | | | | |
|----------|-------|--------------|----------|-------|
| DESIGNER | SIZE | DATE | PART NO. | REV |
| | A | 3/22/04 | #71 CFC | |
| APPROVED | SCALE | RELEASE DATE | WEIGHT | SHEET |

| REVISIONS | | | |
|-----------|-----|-----------------------------|----------|
| ZONE | REV | FINISHES : | DATE |
| | | 605,606,612,613,628,629,630 | |
| | | | APPROVED |

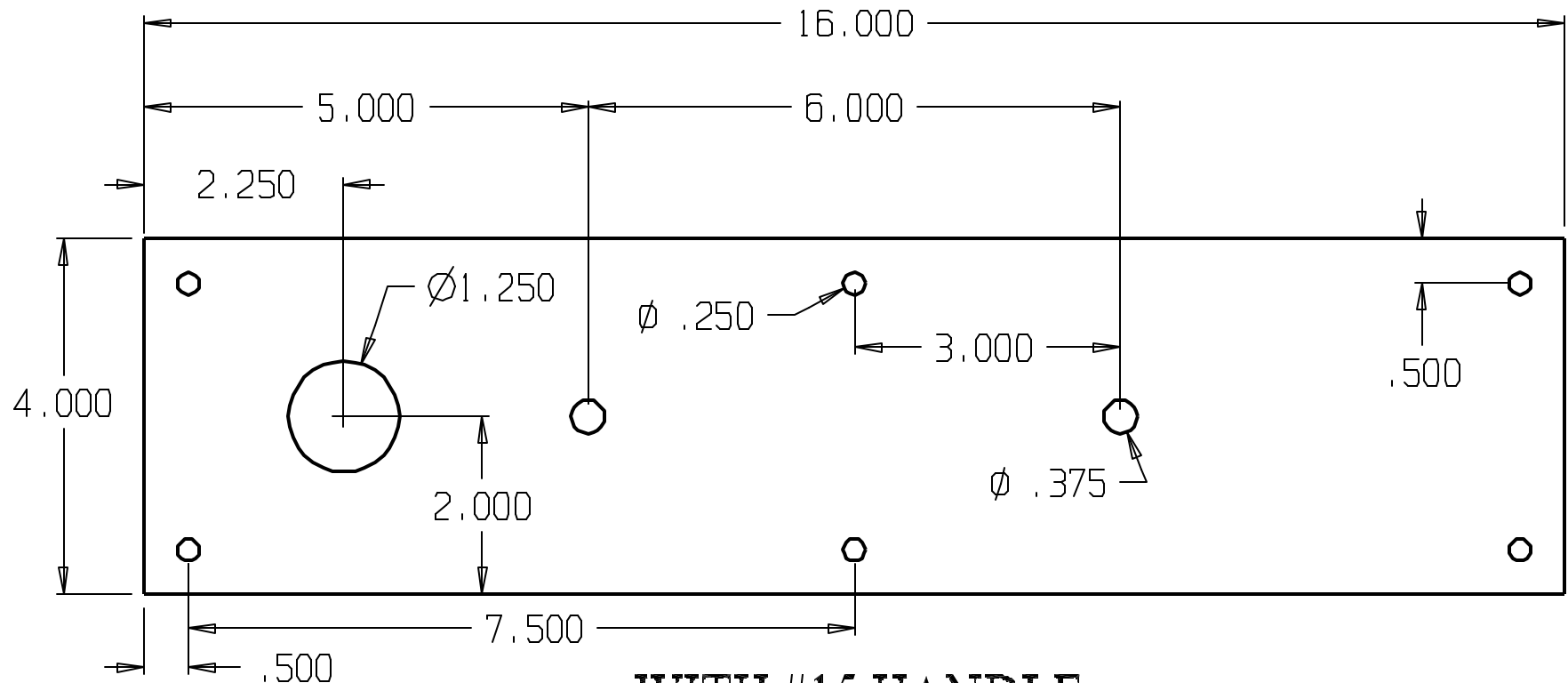

WITH #15 HANDLE

| | | | | | |
|------------------|--|-------|--------------|-----------|-------|
| DON-JO MFG. INC. | | SIZE | DATE | PART NO. | REV |
| DESIGNER | | A | 4/29/04 | #7115 CFC | |
| APPROVED | | SCALE | RELEASE DATE | WEIGHT | SHEET |

| REVISIONS | | | | |
|-----------|-----|---|------|----------|
| ZONE | REV | FINISHES : | DATE | APPROVED |
| | | 605,606,609,612,613,619, 620,626,628,629,630 | | |

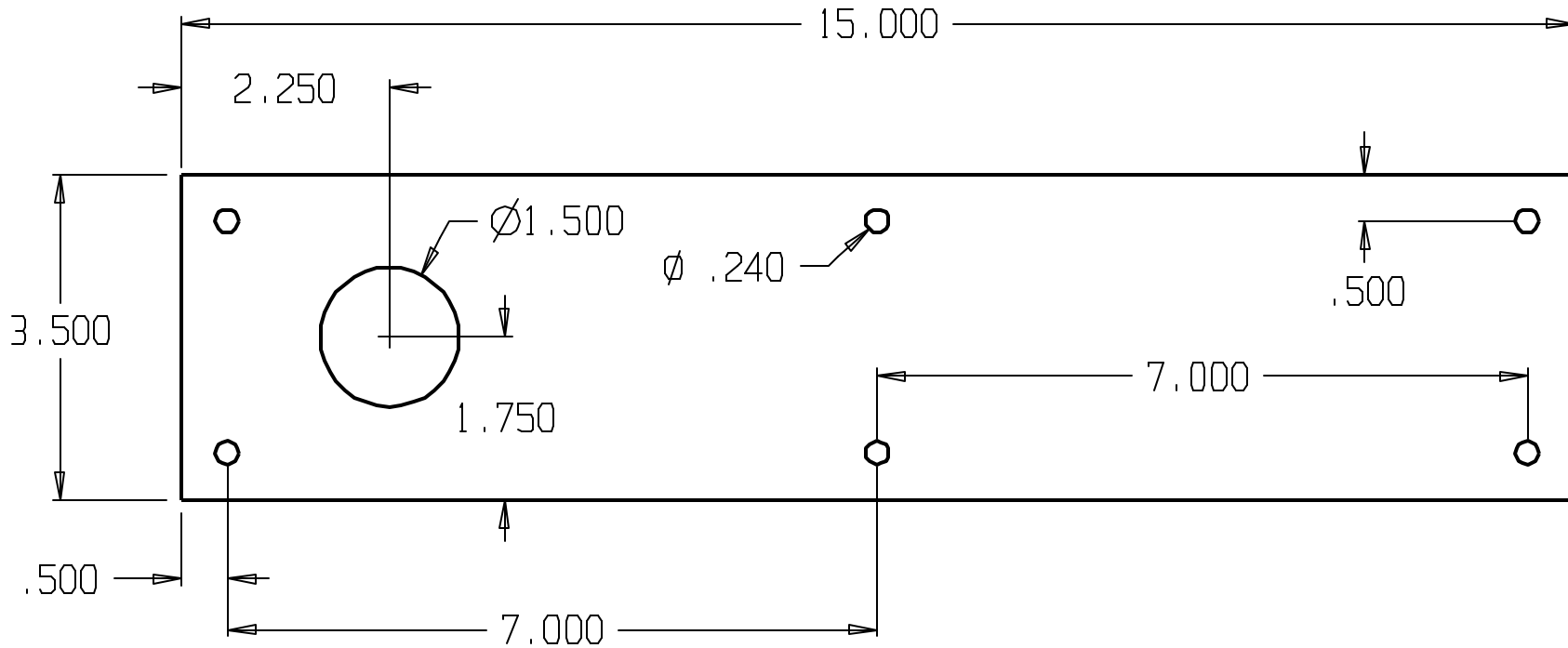

DON-JO MFG. INC.

| | |
|----------|--|
| DESIGNER | |
| APPROVED | |

| | | | |
|-------|--------------|----------|-------|
| SIZE | DATE | PART NO. | REV |
| A | 4/28/04 | #70 CFD | |
| SCALE | RELEASE DATE | WEIGHT | SHEET |

| REVISIONS | | | |
|-----------|-----|-----------------------------------|------|
| ZONE | REV | FINISHES: | DATE |
| | | 605, 606, 612, 613, 628, 629, 630 | |
| | | APPROVED | |

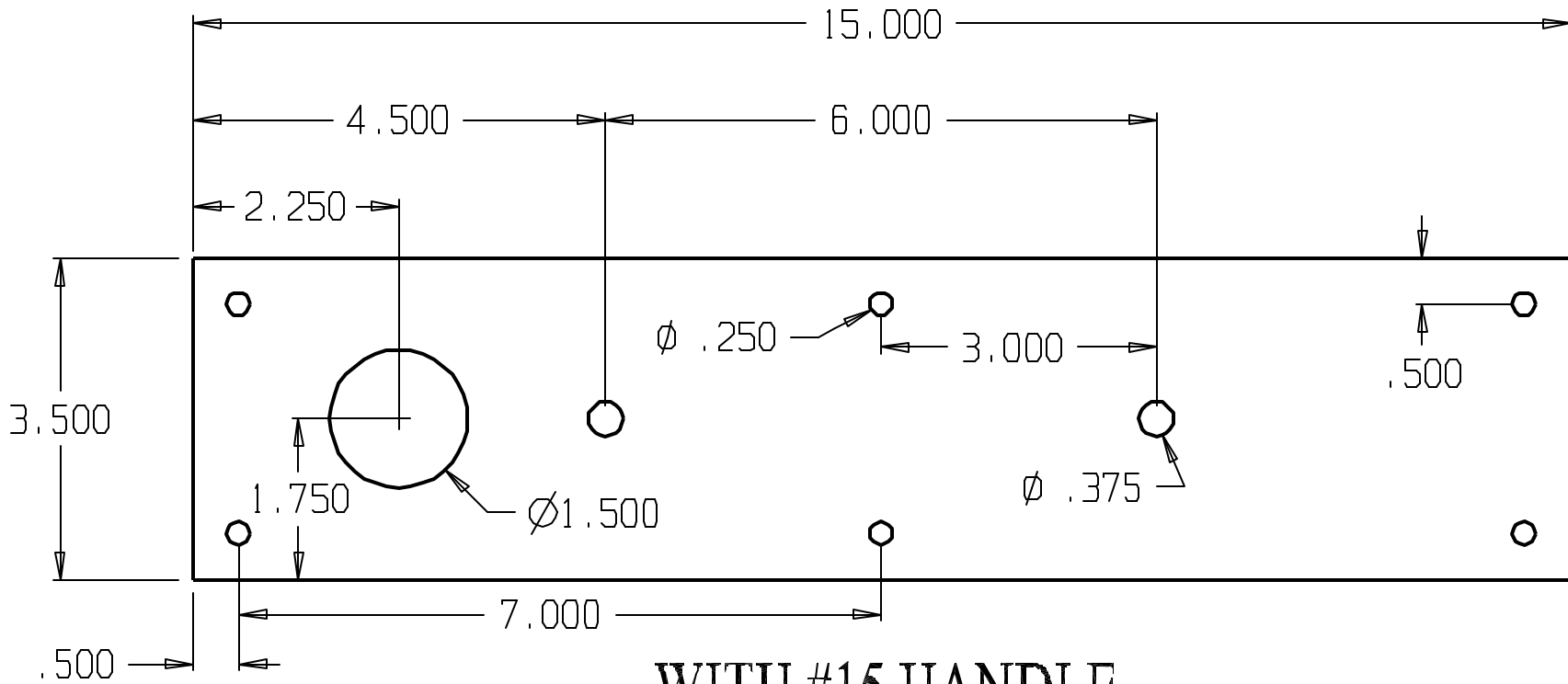

WITH #15 HANDLE

| | | | | | |
|------------------|--|-------|--------------|-----------|-------|
| DON-JO MFG. INC. | | SIZE | DATE | PART NO. | REV |
| DESIGNER | | A | 4/29/04 | #7015 CFD | |
| APPROVED | | SCALE | RELEASE DATE | WEIGHT | SHEET |

| REVISIONS | | | |
|-----------|-----|-----------------------------------|------|
| ZONE | REV | FINISHES: | DATE |
| | | 605, 606, 612, 613, 628, 629, 630 | |
| | | APPROVED | |

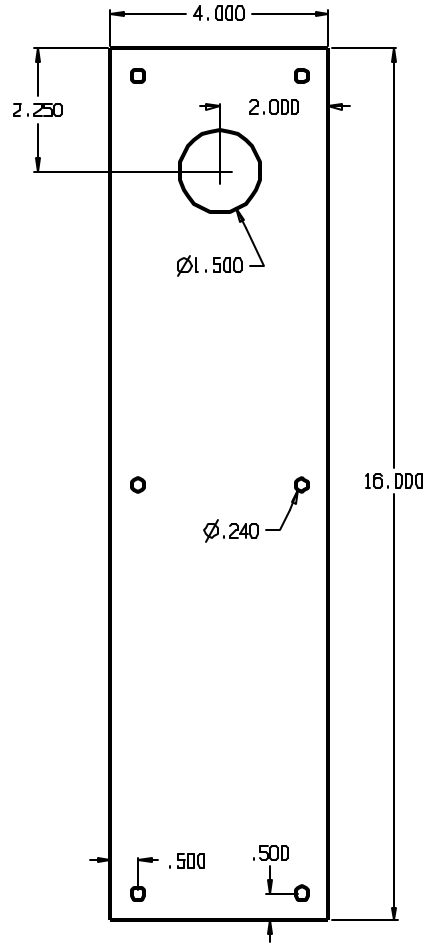

DON-JO MFG. INC.

| | | | | |
|----------|-----------|-----------------|---------------------|-------|
| DESIGNER | SIZE A | DATE 3/22/04 | PART NO. #71 CFD | REV |
| APPROVED | SCALE | RELEASE DATE | WEIGHT | SHEET |

| REVISIONS | | | | |
|-----------|-----|---|------|----------|
| ZONE | REV | FINISHES : | DATE | APPROVED |
| | | 605,606,609,612,613,619, 620,626,628,629,630 | | |

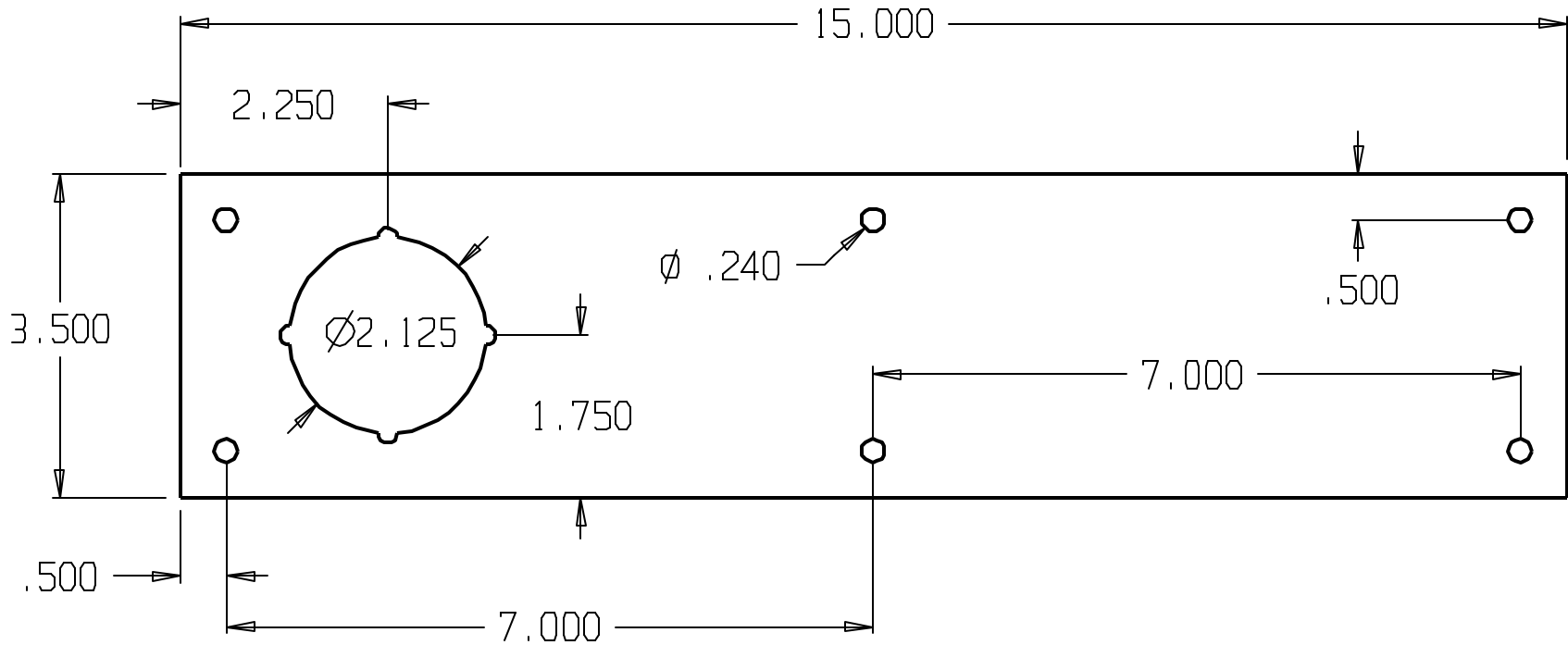

| | | | | | |
|------------------|--|-------|--------------|----------|-------|
| DON-JO MFG. INC. | | SIZE | DATE | PART NO. | REV |
| DESIGNER | | A | 4/28/04 | #70 CFK | |
| APPROVED | | SCALE | RELEASE DATE | WEIGHT | SHEET |

| REVISIONS | | | |
|-----------|-----|-----------------------------------|----------|
| ZONE | REV | FINISHES: | DATE |
| | | 605, 606, 612, 613, 628, 629, 630 | |
| | | | APPROVED |

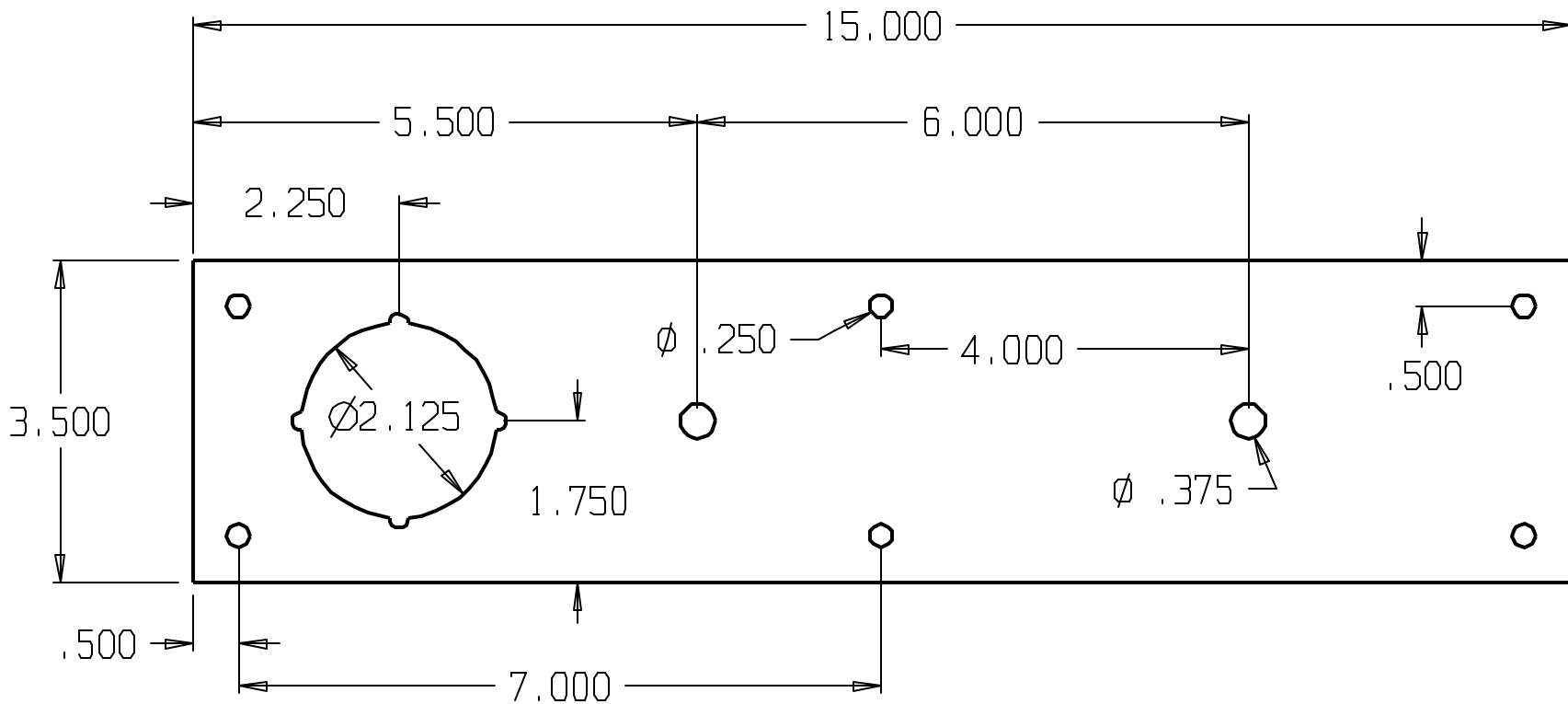

WITH #15 HANDLE

| | | | | | |
|------------------|--|-------|--------------|-----------|-------|
| DON-JO MFG. INC. | | SIZE | DATE | PART NO. | REV |
| DESIGNER | | A | 4/29/04 | #7015 CFK | |
| APPROVED | | SCALE | RELEASE DATE | WEIGHT | SHEET |

| REVISIONS | | | |
|-----------|-----|-----------------------------------|------|
| ZONE | REV | FINISHES: | DATE |
| | | 605, 606, 612, 613, 628, 629, 630 | |
| | | APPROVED | |

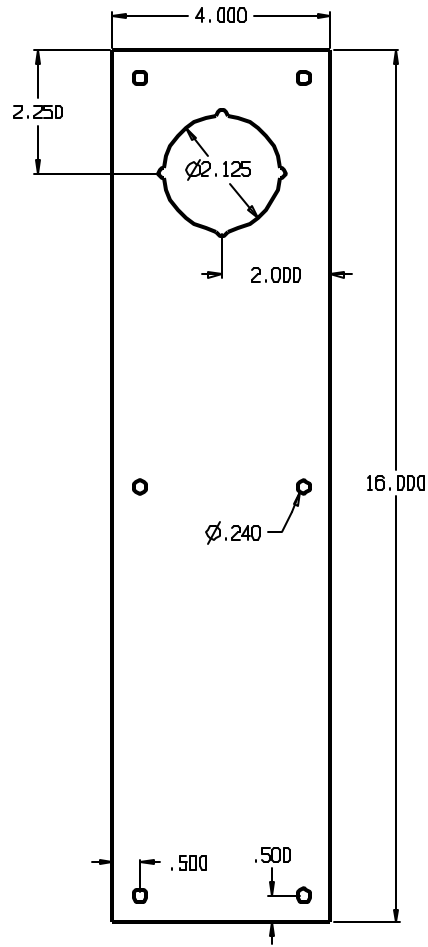

DON-JO MFG. INC.

| | | | | |
|----------|---------|---------------|-------------------|-------|
| DESIGNER | SIZE: A | DATE: 3/22/04 | PART NO.: #71 CFK | REV |
| APPROVED | SCALE | RELEASE DATE | WEIGHT | SHEET |

| REVISIONS | | | | |
|-----------|-----|-----------------------------|------|----------|
| ZONE | REV | FINISHES : | DATE | APPROVED |
| | | 605,606,612,613,628,629,630 | | |

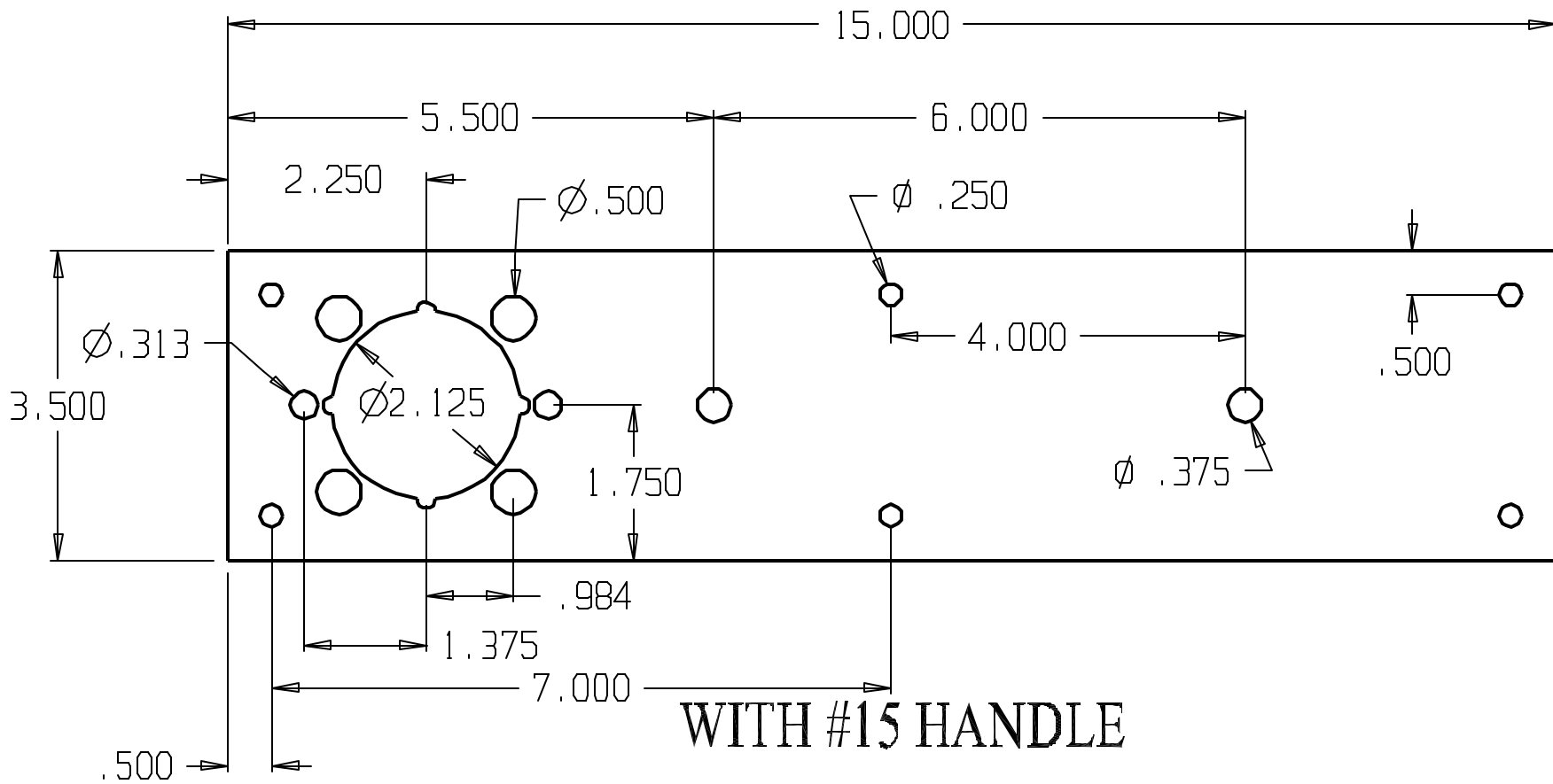

DON-JO MFG. INC.

| | |
|----------|--|
| DESIGNER | |
| APPROVED | |

| | | | |
|-----------|-----------------|-----------------------|-------|
| SIZE A | DATE 4/29/04 | PART NO. #7015 CFL | REV |
| SCALE | RELEASE DATE | WEIGHT | SHEET |

| REVISIONS | | | |
|-----------|-----|-----------------------------|----------|
| ZONE | REV | FINISHES : | DATE |
| | | 605,606,612,613,628,629,630 | |
| | | | APPROVED |

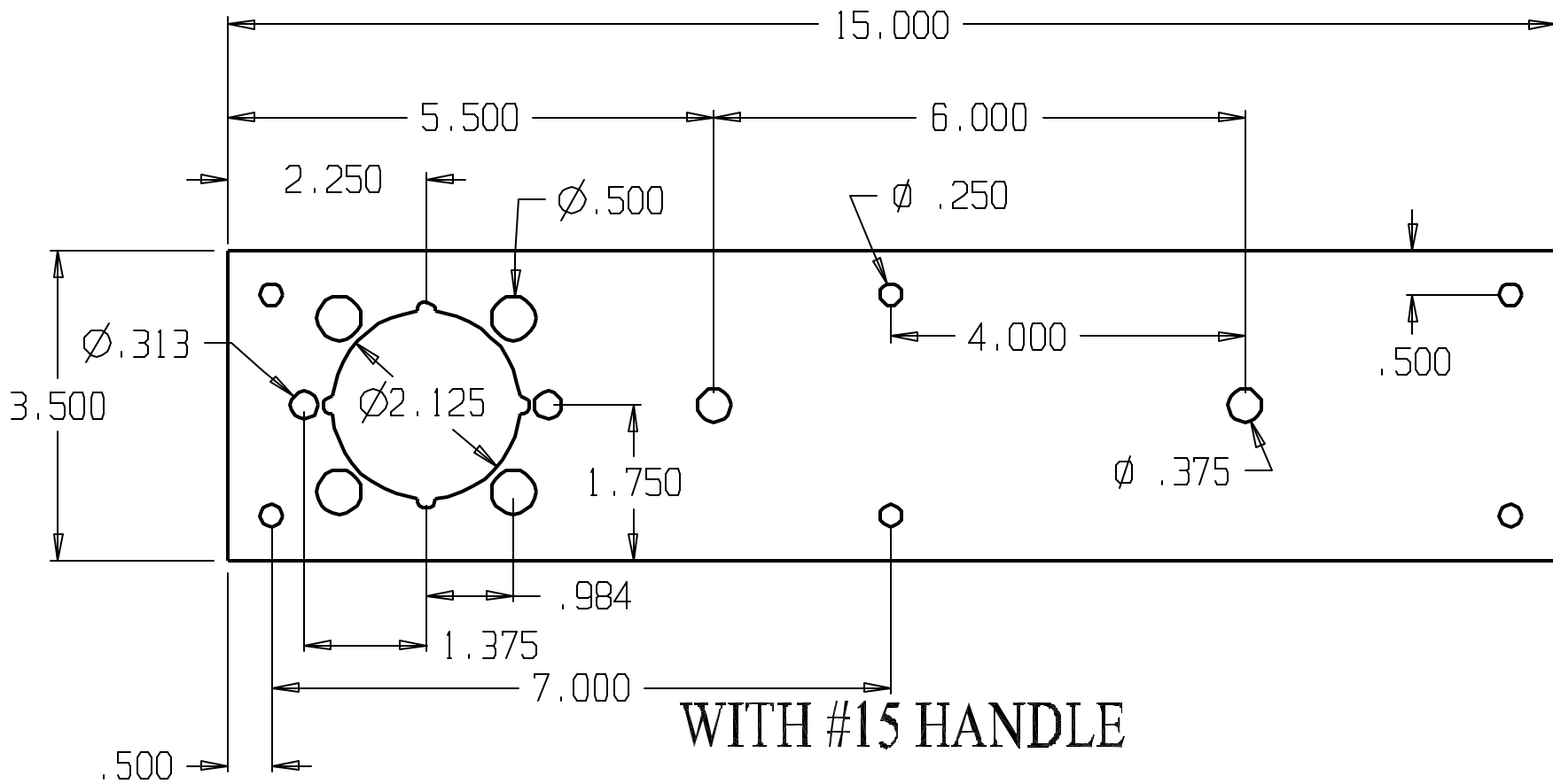

| | | | | | |
|------------------|--|-------|--------------|-----------|-------|
| DON-JO MFG. INC. | | SIZE | DATE | PART NO. | REV |
| DESIGNER | | A | 4/29/04 | #7015 CFL | |
| APPROVED | | SCALE | RELEASE DATE | WEIGHT | SHEET |

| REVISIONS | | | |
|-----------|-----|-----------------------------------|------|
| ZONE | REV | FINISHES: | DATE |
| | | 605, 606, 612, 613, 628, 629, 630 | |
| | | APPROVED | |

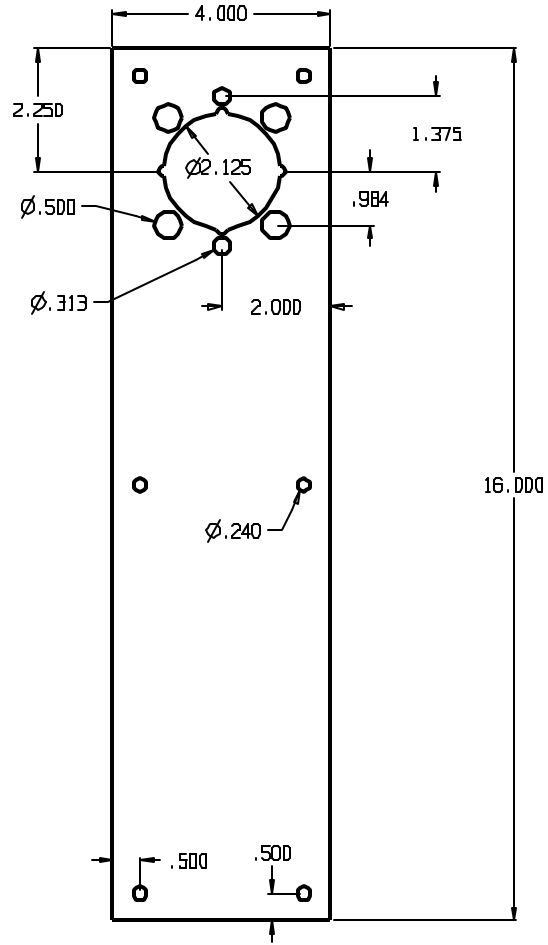

| | | | | | |
|------------------|--|-------|--------------|----------|-------|
| DON-JO MFG. INC. | | SIZE | DATE | PART NO. | REV |
| DESIGNER | | A | 3/22/04 | #71 CFL | |
| APPROVED | | SCALE | RELEASE DATE | WEIGHT | SHEET |

DWG NO:

SH:

REV:

REVISIONS

| ZONE | REV | FINISHES: | DATE | APPROVED |
|------|-----|-------------------------|------|----------|
| | | 605, 606, 613, 625, 626 | | |

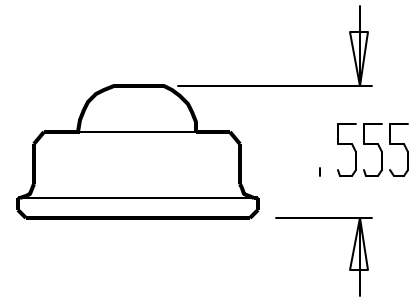
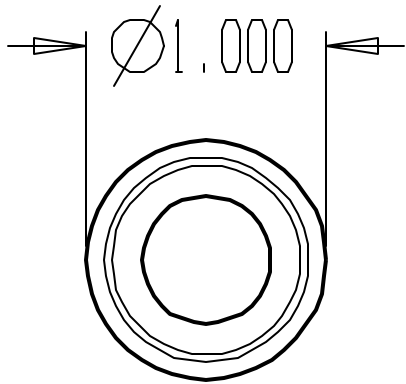

DON-JO MFG. INC.

DESIGNER

APPROVED

SIZE
A

DATE:
2/10/04

PART NO.
#1400

REV

SCALE

RELEASE DATE

WEIGHT

SHEET

| REVISIONS | | | | |
|-----------|-----|---------------------|------|----------|
| ZONE | REV | FINISHES: | DATE | APPROVED |
| | | GRAY & WHITE RUBBER | | |

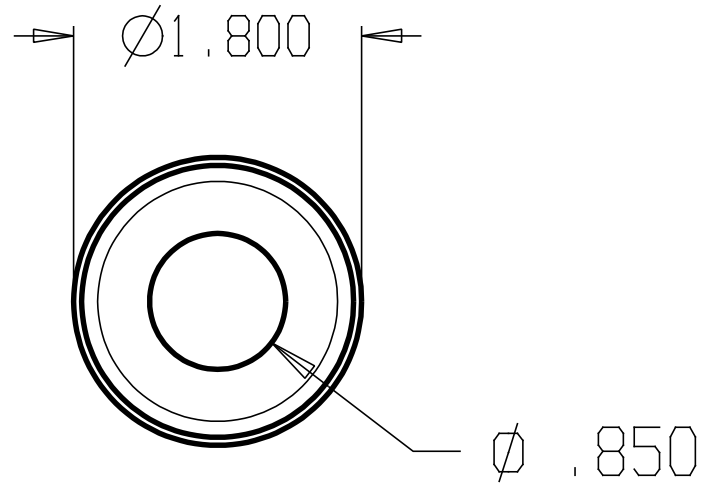
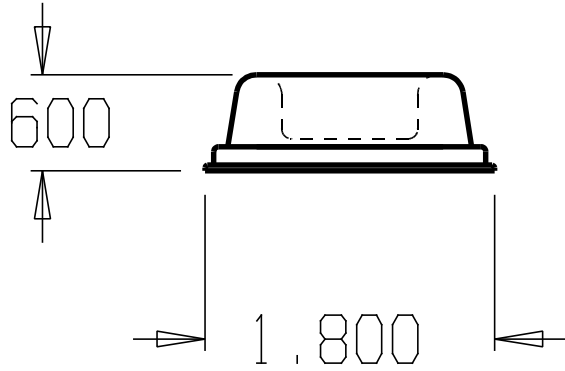

DON-JO MFG. INC.

DESIGNER

APPROVED

| | | | |
|-----------|------------------|-------------------|-------|
| SIZE A | DATE: 2/10/04 | PART NO. #1401 | REV |
| SCALE | RELEASE DATE | WEIGHT | SHEET |

| REVISIONS | | | | |
|-----------|-----|-----------|------|----------|
| ZONE | REV | FINISHES: | DATE | APPROVED |
| | | 626 | | |

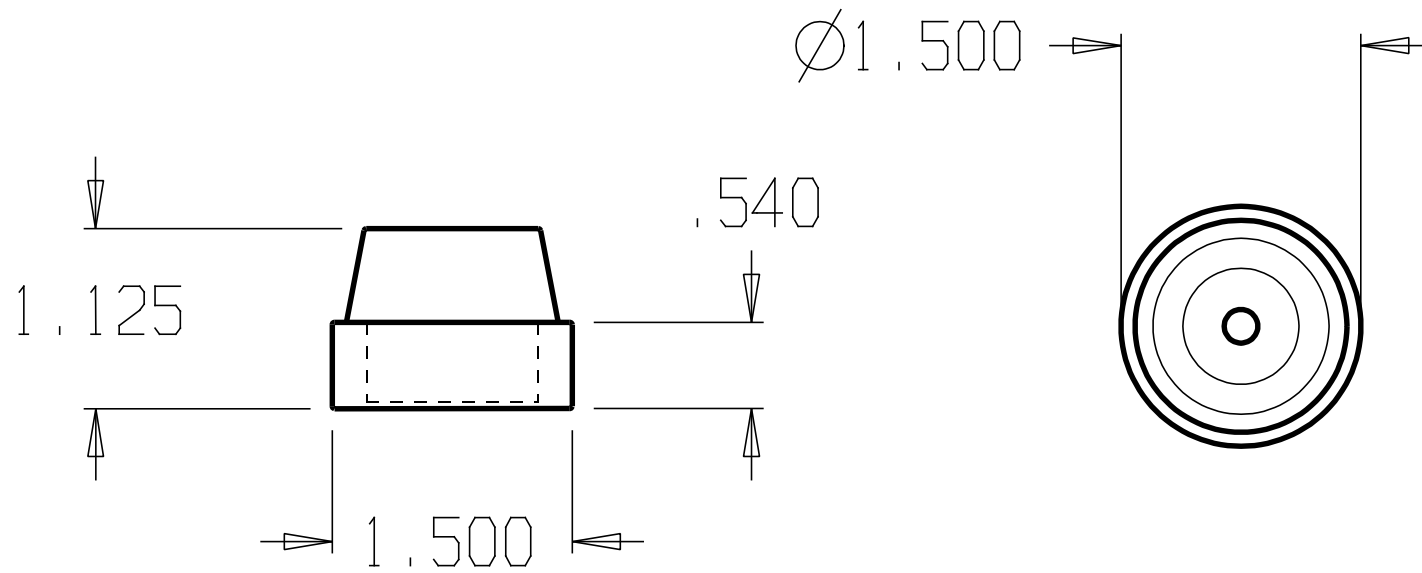

DON-JO MFG. INC.

| | |
|----------|--|
| DESIGNER | |
| APPROVED | |

| | | | |
|-----------|------------------|-------------------|-------|
| SIZE A | DATE: 2/10/04 | PART NO. #1402 | REV |
| SCALE | RELEASE DATE | WEIGHT | SHEET |

DWG NO

SH

REV

REVISIONS

| ZONE | REV | FINISHES : | DATE | APPROVED |
|------|-----|-----------------------------------|------|----------|
| | | 605, 606, 612, 613, 625, 626, 630 | | |

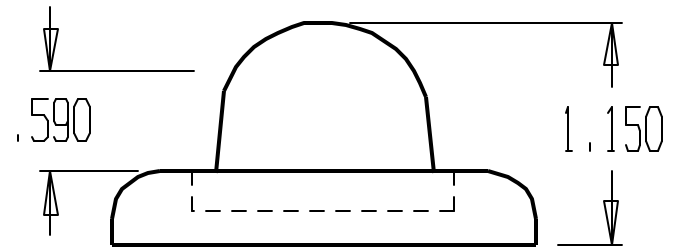
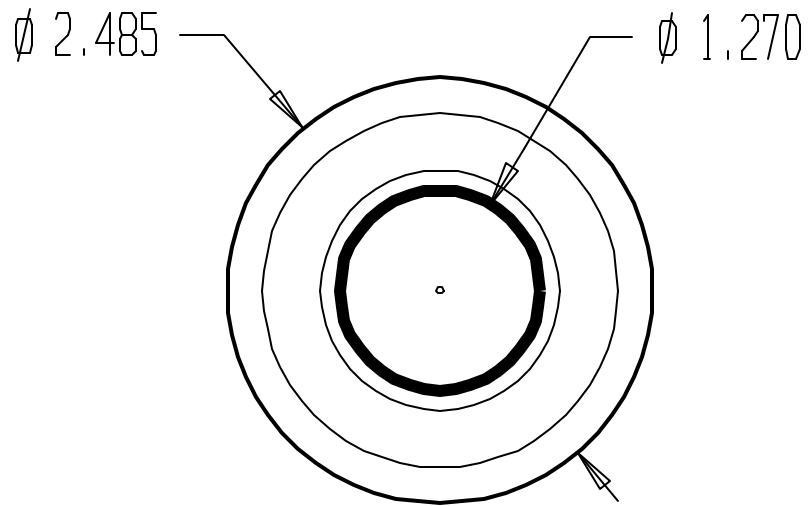

DON-JO MFG. INC.

DESIGNER

APPROVED

SIZE
A

DATE: 2/19/04

PART NO.

#1406

REV

SCALE

RELEASE DATE

WEIGHT

SHEET

| REVISIONS | | | | |
|-----------|-----|---|------|----------|
| ZONE | REV | FINISHES: 605, 606, 612, 613, 619, 620, 625, 626, 630 | DATE | APPROVED |
| | | | | |

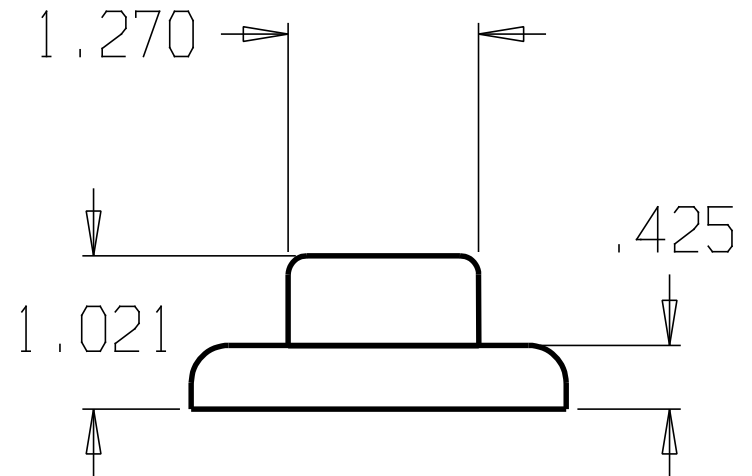
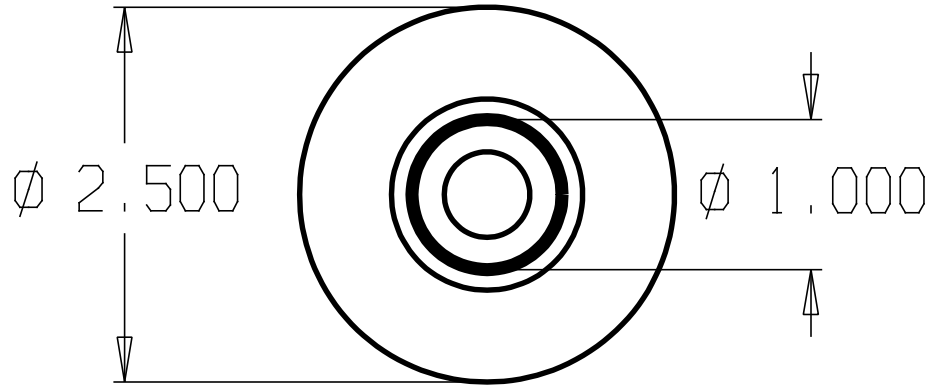

DON-JO MFG. INC.

DESIGNER
APPROVED

| | | | |
|-----------|------------------|-------------------|-------|
| SIZE A | DATE: 2/19/04 | PART NO. #1407 | REV |
| SCALE | RELEASE DATE | WEIGHT | SHEET |

| REVISIONS | | | |
|-----------|-----|------------|----------|
| ZONE | REV | FINISHES : | DATE |
| | | 626 | |
| | | | APPROVED |

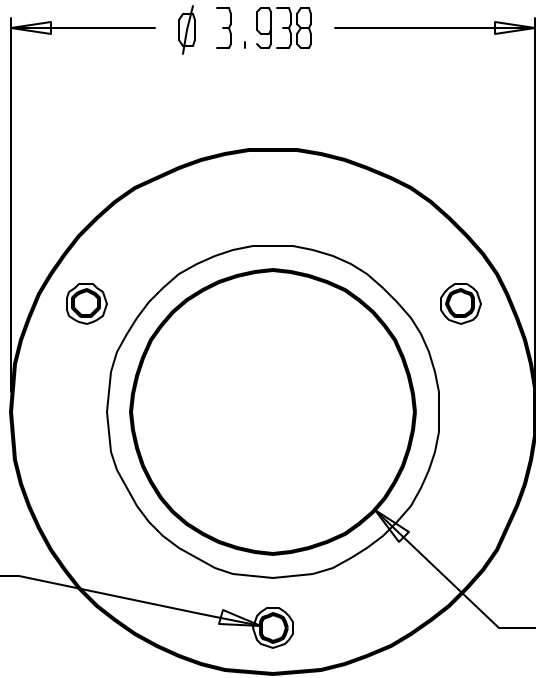

Ø .200
C' INK FOR
#6 SCREW

Ø 2.125

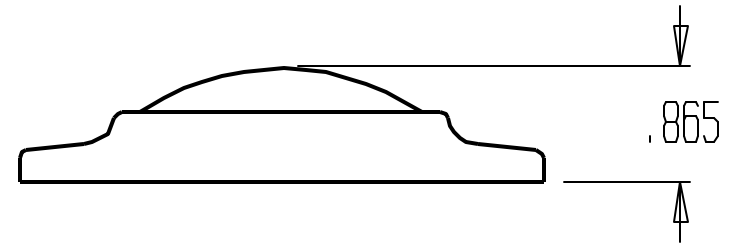

.865

DON-JO MFG. INC.

DESIGNER
APPROVED

| | | | |
|-----------|------------------|-------------------|-------|
| SIZE A | DATE: 2/19/04 | PART NO. #1410 | REV |
| SCALE | RELEASE DATE | WEIGHT | SHEET |

DWG NO

SH

REV

REVISIONS

ZONE

REV

FINISHES:

626

DATE

APPROVED

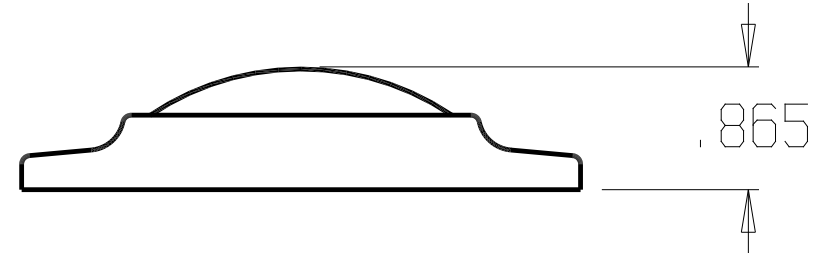
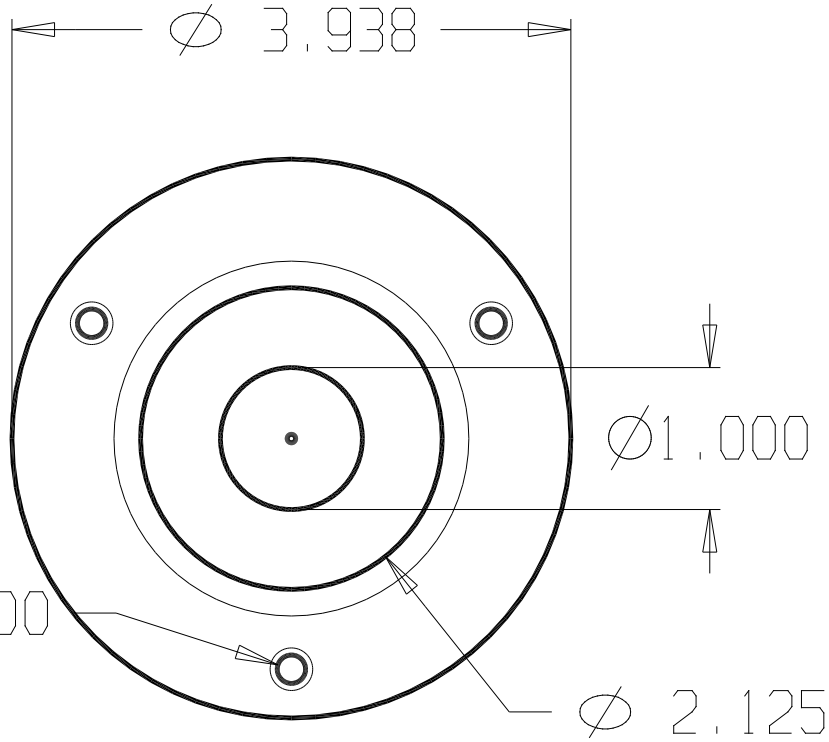

DON-JO MFG. INC.

DESIGNER

APPROVED

| | | | |
|-------|--------------|----------|-------|
| SIZE | DATE: | PART NO. | REV |
| A | 1/18/15 | #1411 | |
| SCALE | RELEASE DATE | WEIGHT | SHEET |

| REVISIONS | | | |
|-----------|-----|-------------|----------|
| ZONE | REV | FINISHES: | DATE |
| | | 605,613,626 | APPROVED |

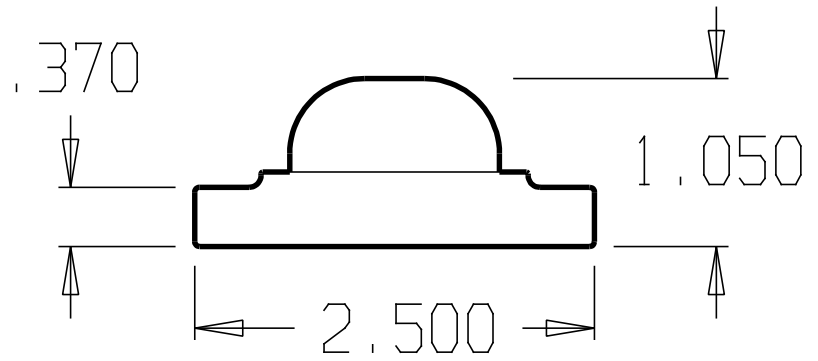
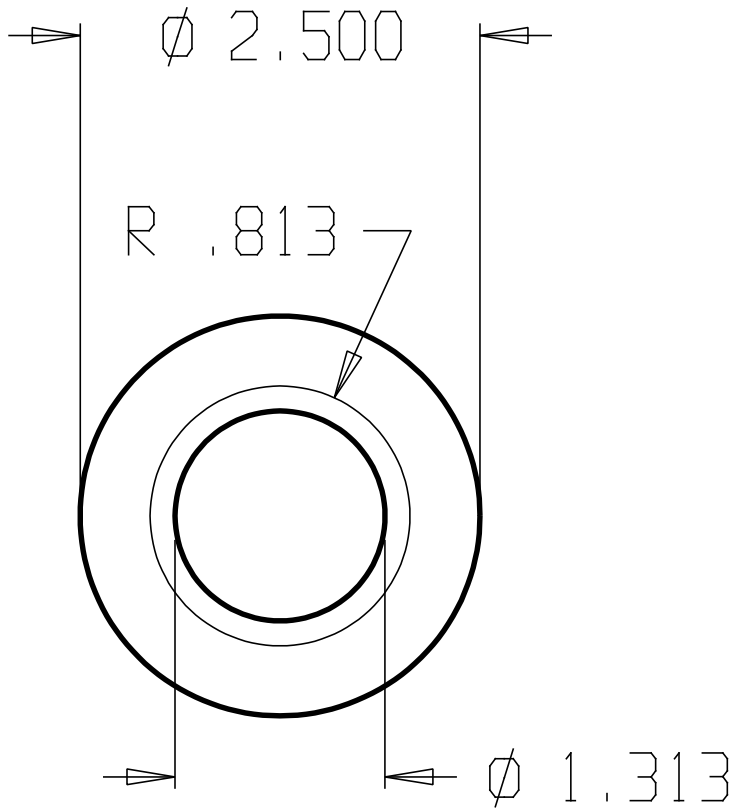

DON-JO MFG. INC.

| | | | | |
|----------|-------|--------------|----------|-------|
| DESIGNER | SIZE | DATE: | PART NO. | REV |
| | A | 2/10/04 | #1412 | |
| APPROVED | SCALE | RELEASE DATE | WEIGHT | SHEET |

| REVISIONS | | | | |
|-----------|-----|-------------|------|----------|
| ZONE | REV | FINISHES: | DATE | APPROVED |
| | | 605,613,626 | | |

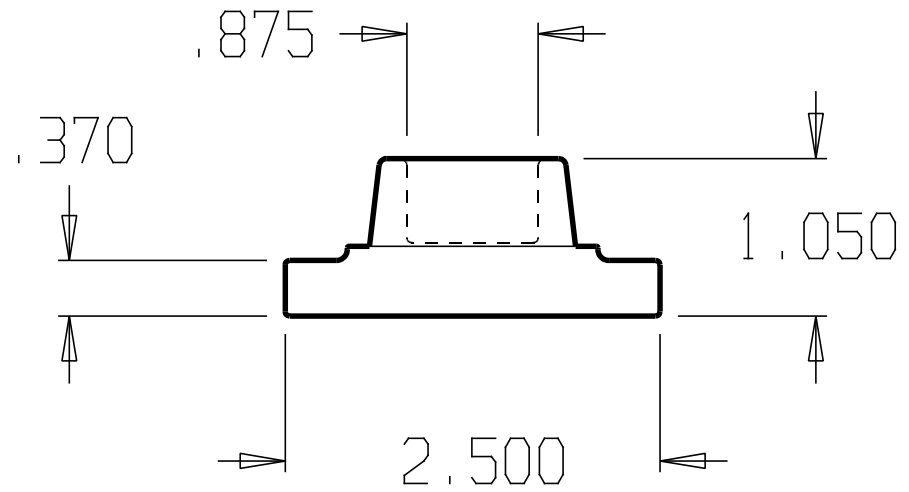
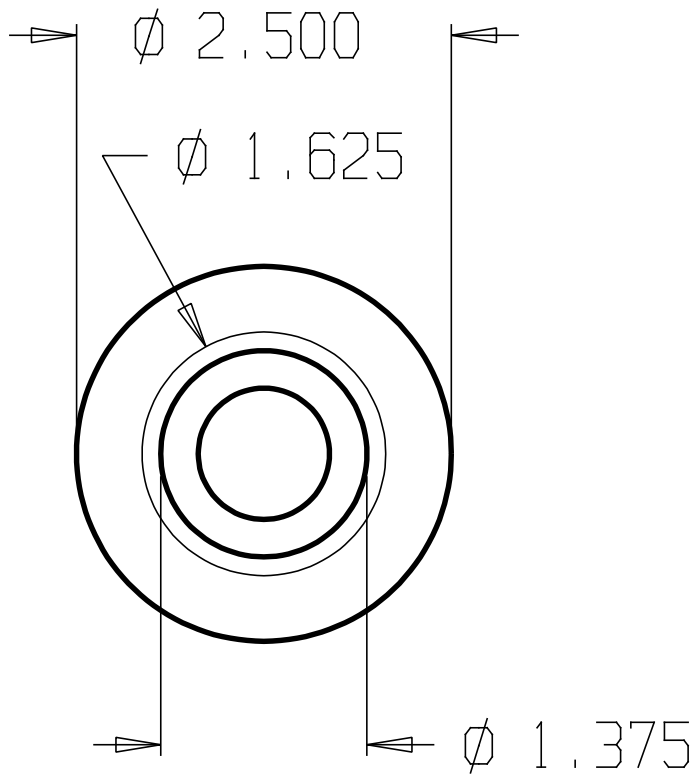

| | | | | |
|-------------------------|-----------|------------------|-------------------|-------|
| DON-JO MFG. INC. | | | | |
| DESIGNER | SIZE A | DATE: 2/10/04 | PART NO. #1413 | REV |
| APPROVED | SCALE | RELEASE DATE | WEIGHT | SHEET |

| REVISIONS | | | |
|-----------|-----|-------------|------|
| ZONE | REV | FINISHES: | DATE |
| | | 605,613,626 | |
| | | APPROVED | |

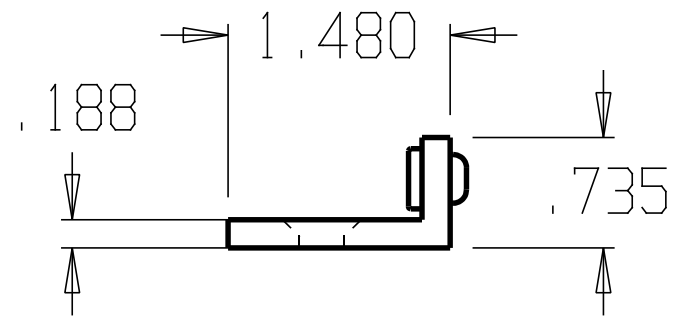
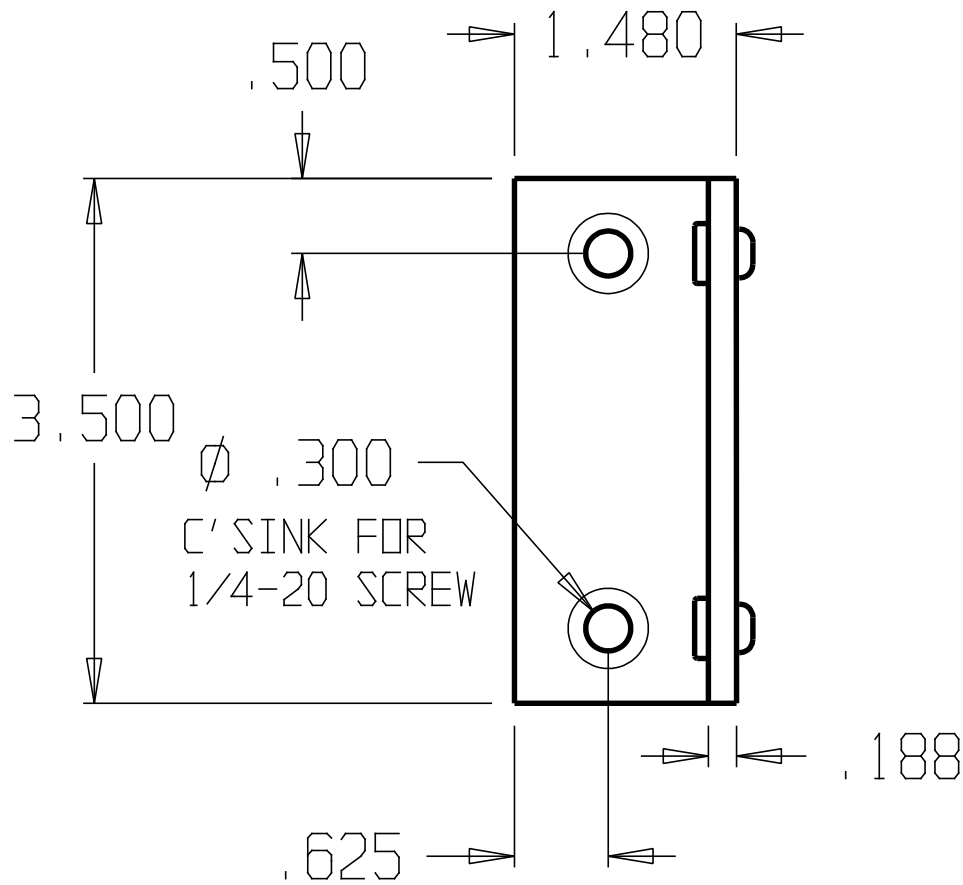

DON-JO MFG. INC.

DESIGNER
APPROVED

SIZE: A
SCALE

DATE: 2/10/04

PART NO. #1420

REV

RELEASE DATE WEIGHT SHEET

| REVISIONS | | | | |
|-----------|-----|-------------|------|----------|
| ZONE | REV | FINISHES: | DATE | APPROVED |
| | | 605,613,626 | | |

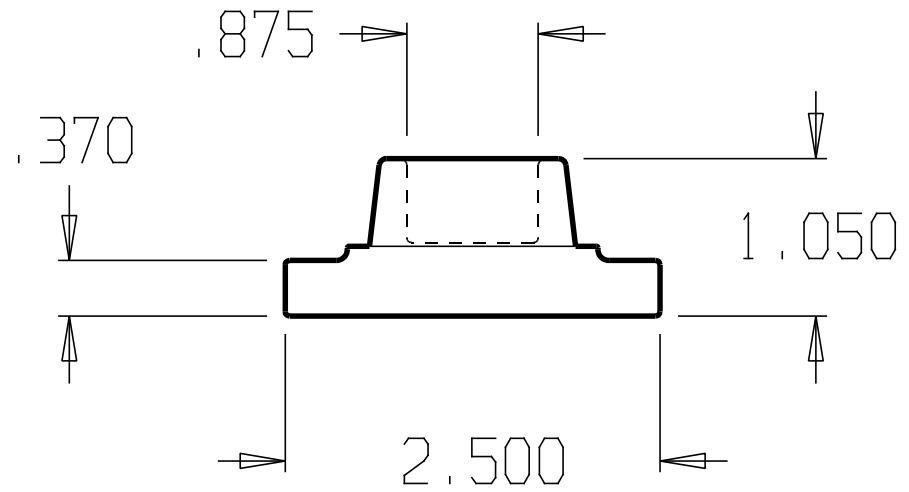
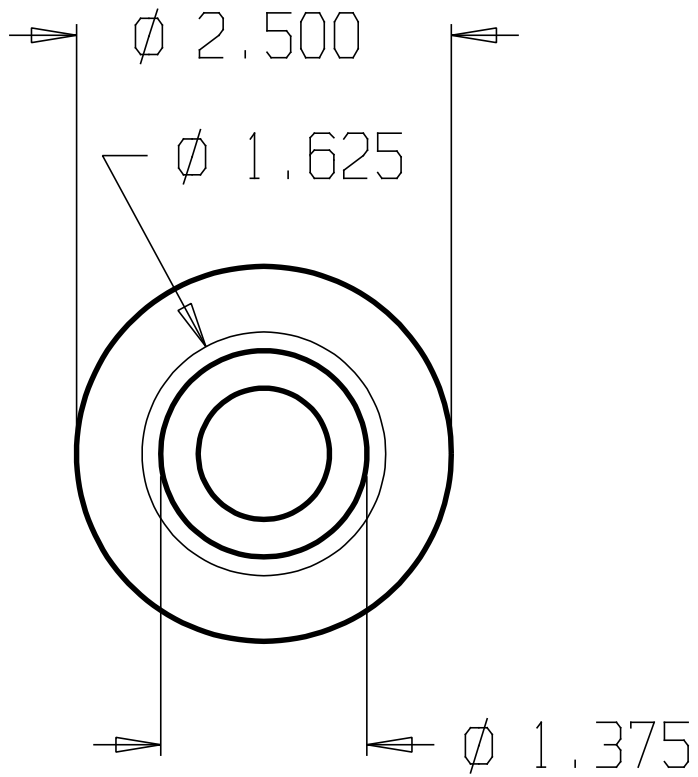

| | | | | | |
|------------------|--|-------|--------------|----------|-------|
| DON-JO MFG. INC. | | SIZE | DATE: | PART NO. | REV |
| DESIGNER | | A | 2/10/04 | #1413 | |
| APPROVED | | SCALE | RELEASE DATE | WEIGHT | SHEET |

| REVISIONS | | | | |
|-----------|-----|---------------------|------|----------|
| ZONE | REV | FINISHES: | DATE | APPROVED |
| | | 605,613,619,620,626 | | |

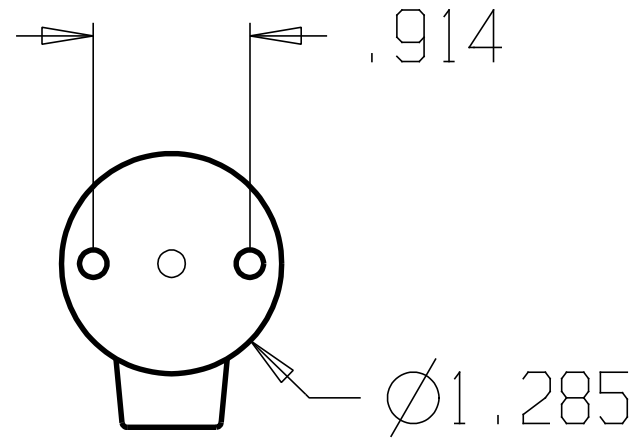
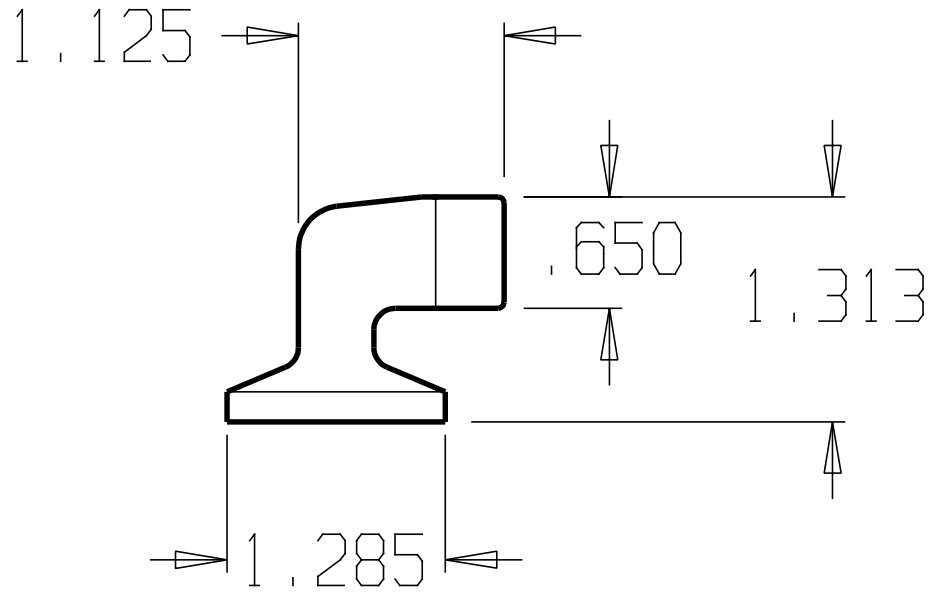

DON-JO MFG. INC.

DESIGNER
APPROVED

SIZE: A
SCALE

DATE: 2/10/04

PART NO. #1432

REV

RELEASE DATE WEIGHT SHEET

| REVISIONS | | | |
|-----------|-----|---|------|
| ZONE | REV | FINISHES: 605,606,612,613, 619,620,625,626 | DATE |
| | | APPROVED | |
| | | | |

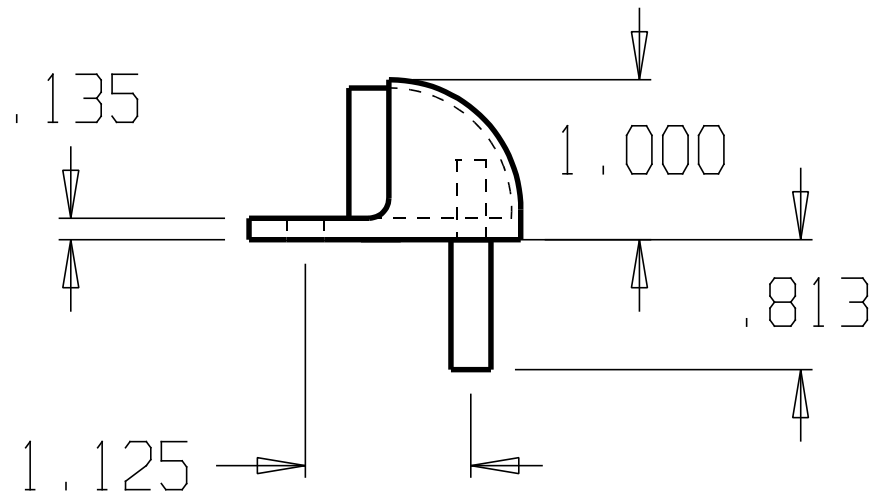
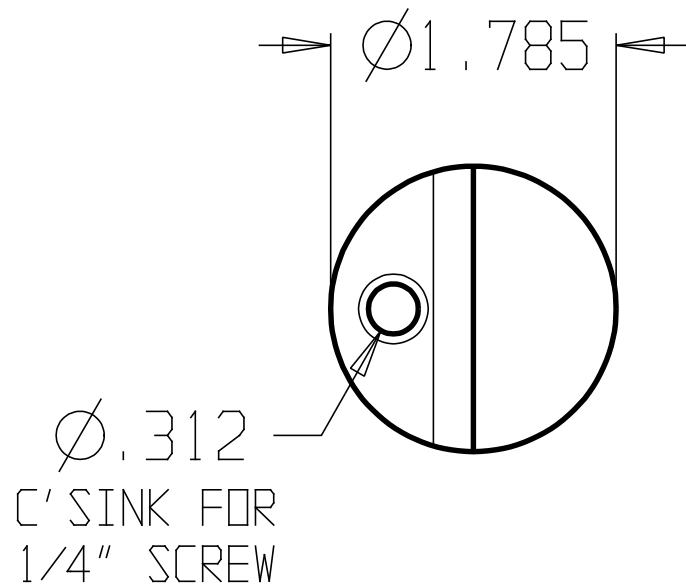

DON-JO MFG. INC.

| | | | | |
|----------|-----------|------------------|-------------------|-------|
| DESIGNER | SIZE A | DATE: 2/19/04 | PART NO. #1440 | REV |
| APPROVED | SCALE | RELEASE DATE | WEIGHT | SHEET |

| REVISIONS | | | |
|-----------|-----|---|------|
| ZONE | REV | FINISHES: 605,606,612,613, 619,620,625,626 | DATE |
| | | APPROVED | |
| | | | |

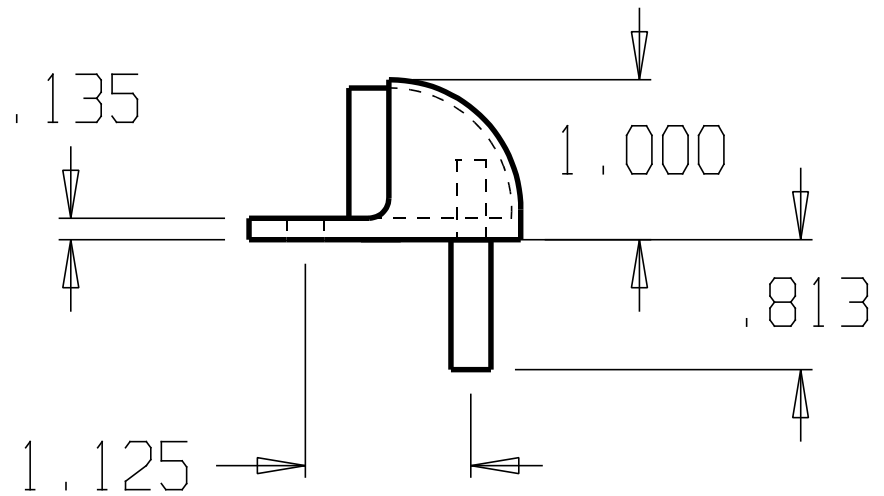
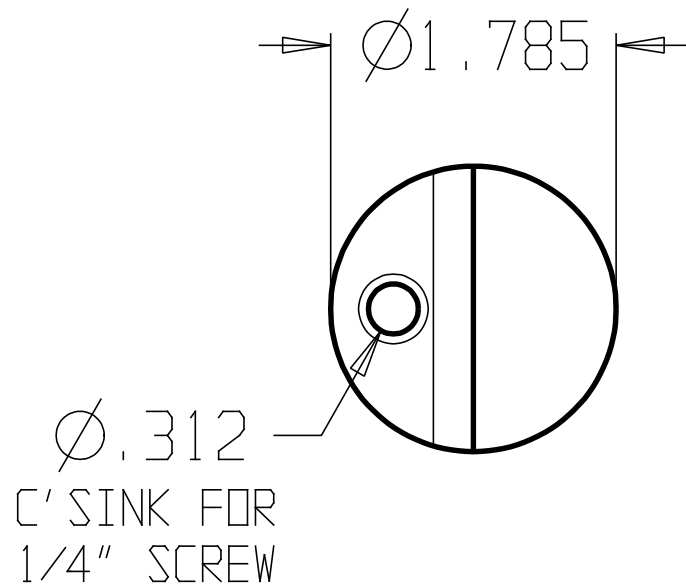

DON-JO MFG. INC.

| | | | | |
|----------|-----------|------------------|-------------------|-------|
| DESIGNER | SIZE A | DATE: 2/19/04 | PART NO. #1440 | REV |
| APPROVED | SCALE | RELEASE DATE | WEIGHT | SHEET |

| REVISIONS | | | | |
|-----------|-----|-------------|------|----------|
| ZONE | REV | FINISHES: | DATE | APPROVED |
| | | 605,613,626 | | |

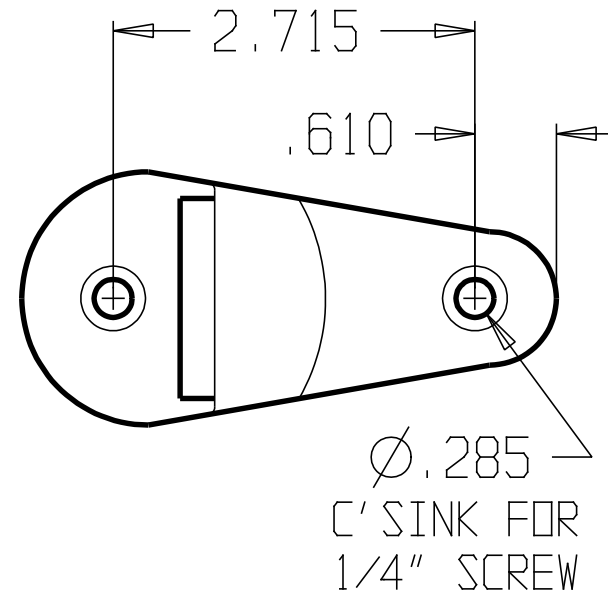
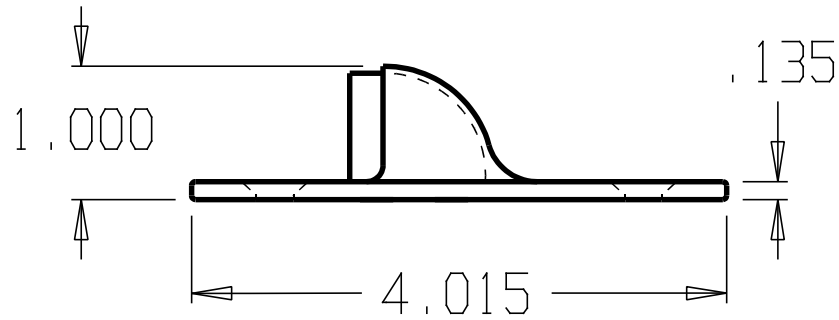

DON-JO MFG. INC.

| | | | | |
|----------|-----------|------------------|-------------------|-------|
| DESIGNER | SIZE A | DATE: 2/19/04 | PART NO. #1443 | REV |
| APPROVED | SCALE | RELEASE DATE | WEIGHT | SHEET |

| REVISIONS | | | | |
|-----------|-----|---------------|------|----------|
| ZONE | REV | FINISHES: | DATE | APPROVED |
| | | 605, 613, 626 | | |

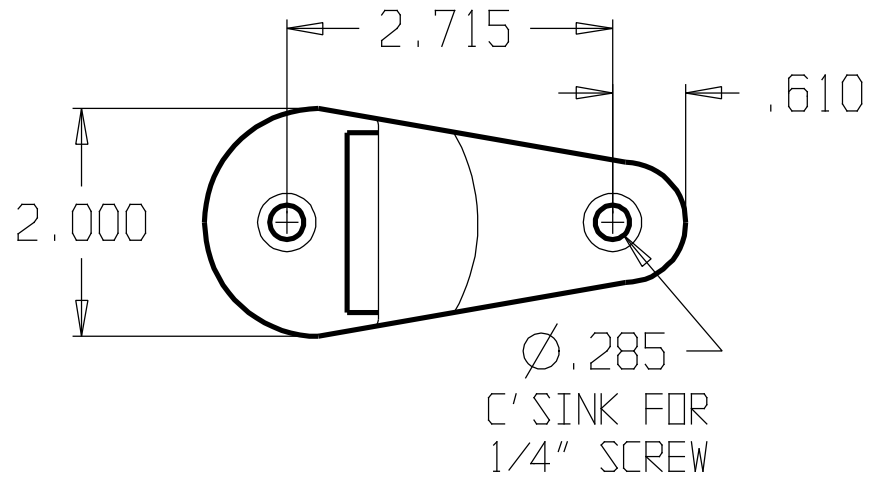
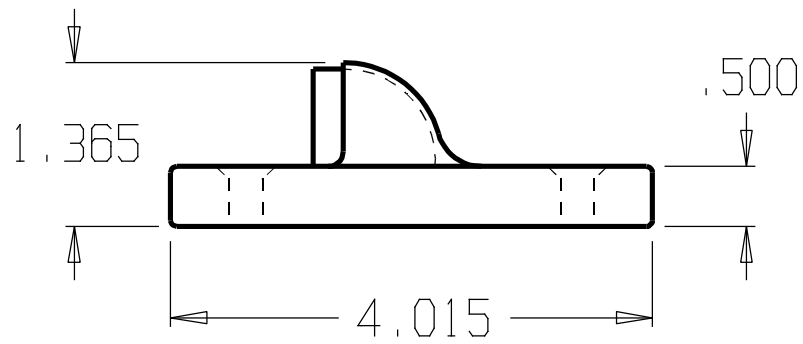

DON-JO MFG. INC.

| | | | | |
|----------|-----------|------------------|-------------------|-------|
| DESIGNER | SIZE A | DATE: 2/19/04 | PART NO. #1444 | REV |
| APPROVED | SCALE | RELEASE DATE | WEIGHT | SHEET |

| REVISIONS | | | | |
|-----------|-----|-----------------|------|----------|
| ZONE | REV | FINISHES: | DATE | APPROVED |
| | | 605,613,625,626 | | |

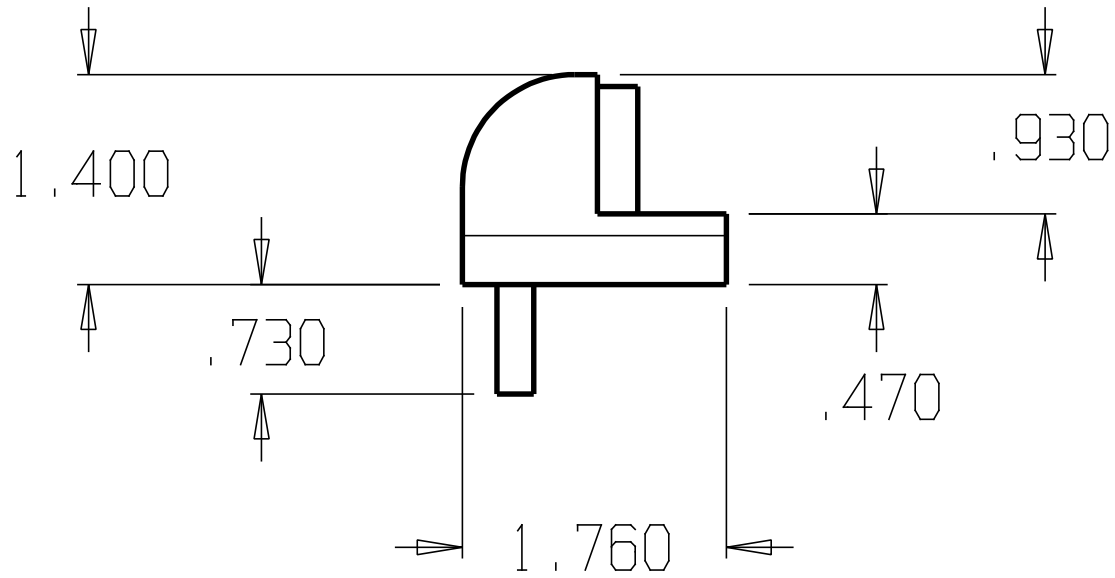

DON-JO MFG. INC.

| | | | | |
|----------|-----------|------------------|-------------------|-------|
| DESIGNER | SIZE A | DATE: 2/19/04 | PART NO. #1445 | REV |
| APPROVED | SCALE | RELEASE DATE | WEIGHT | SHEET |

| REVISIONS | | | | |
|-----------|-----|-----------------|------|----------|
| ZONE | REV | FINISHES: | DATE | APPROVED |
| | | 605,613,625,626 | | |

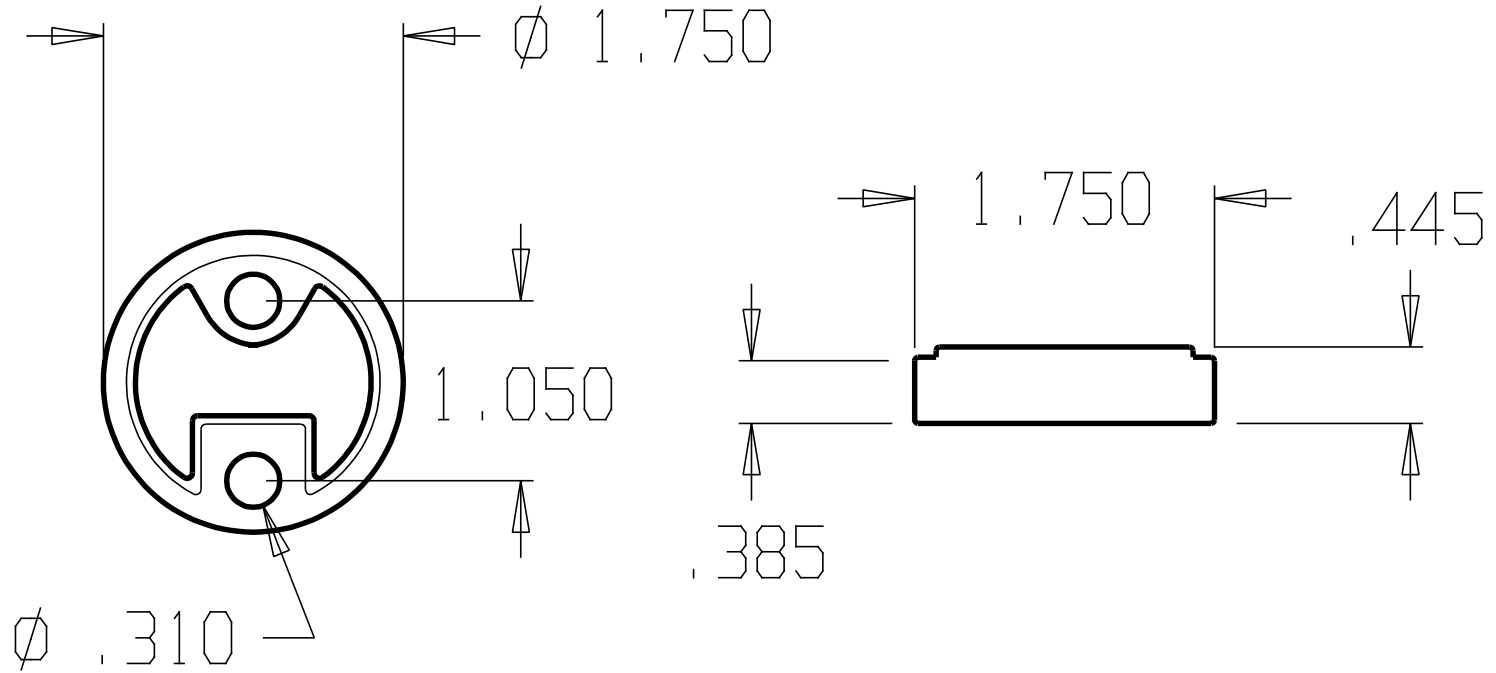

DON-JO MFG. INC.

| | | | | | |
|----------|--|-----------|------------------|-------------------|-------|
| DESIGNER | | SIZE A | DATE: 3/11/04 | PART NO. #1446 | REV |
| APPROVED | | SCALE | RELEASE DATE | WEIGHT | SHEET |

| REVISIONS | | | | |
|-----------|-----|------------|------|----------|
| ZONE | REV | FINISHES : | DATE | APPROVED |
| | | | | |

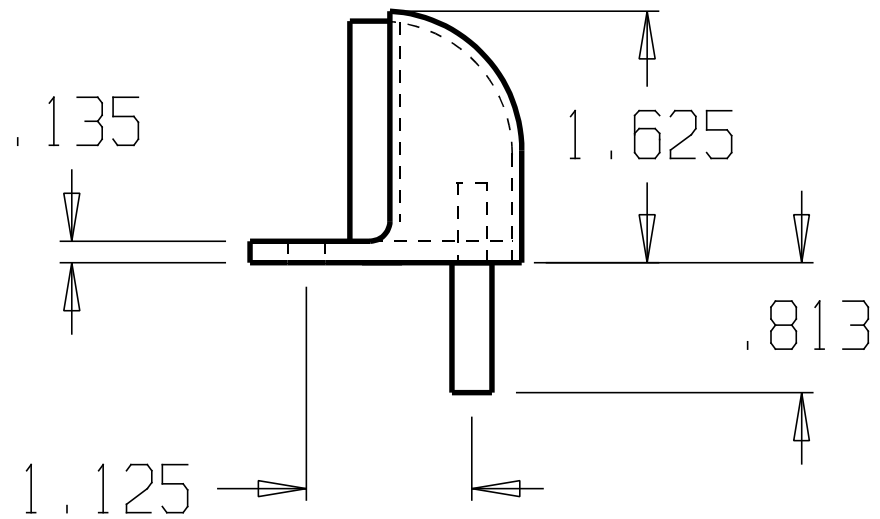
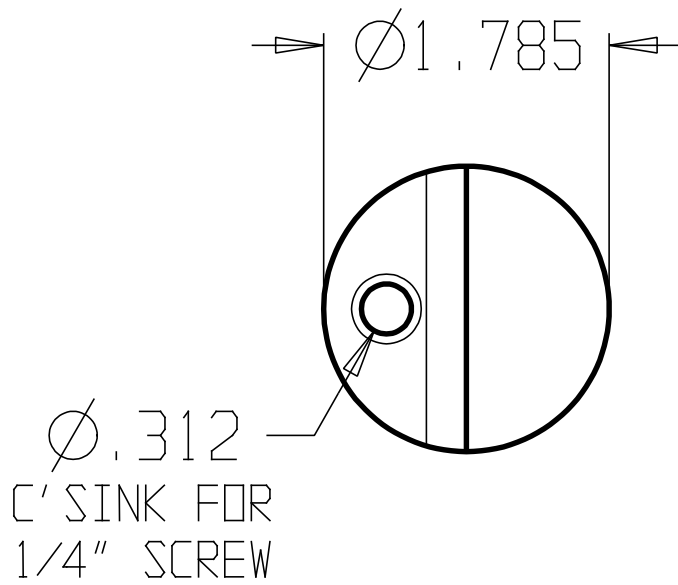

| | | | | | | | | |
|------------------|--|-------|--------------|--------|-------|-------|----------|-----|
| DON-JO MFG. INC. | | | | | SIZE | DATE: | PART NO. | REV |
| DESIGNER | | A | 10/7/05 | #1447 | | | | |
| APPROVED | | SCALE | RELEASE DATE | WEIGHT | SHEET | | | |

| REVISIONS | | | | |
|-----------|-----|-------------|------|----------|
| ZONE | REV | FINISHES: | DATE | APPROVED |
| | | 605,613,626 | | |

Ø .195
C' SINK FOR
#8 SCREW

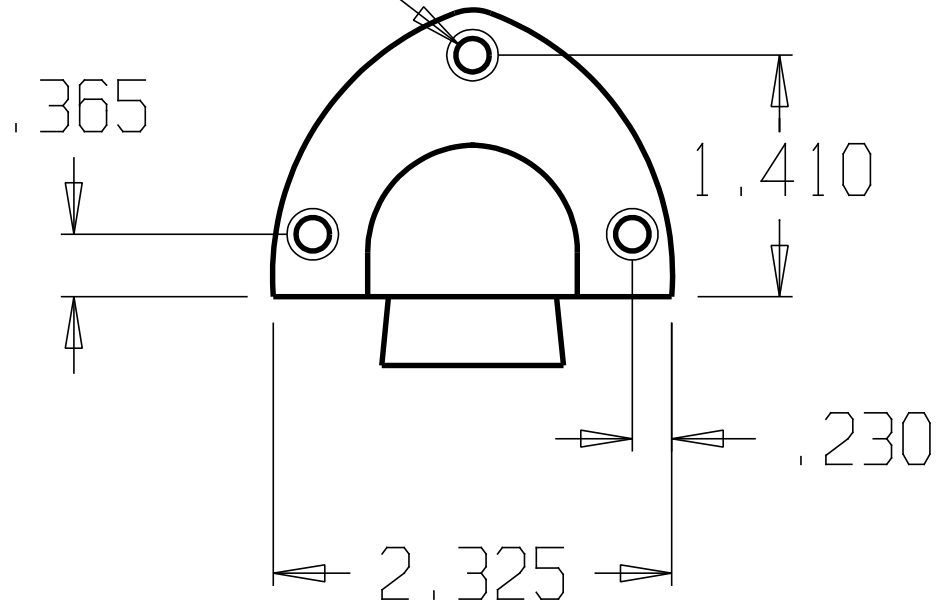
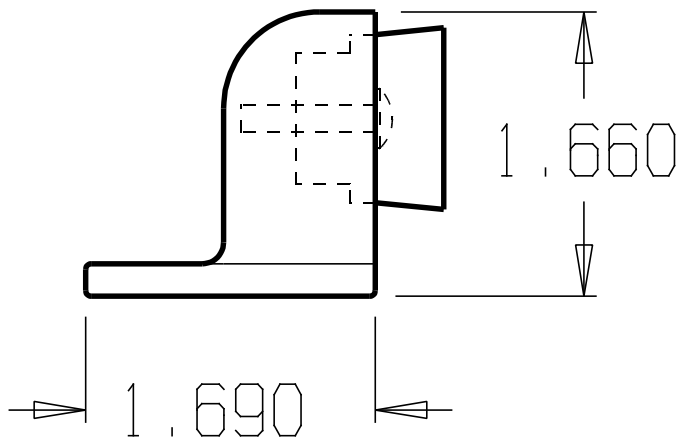

DON-JO MFG. INC.

| | | | | |
|----------|-----------|------------------|-------------------|-------|
| DESIGNER | SIZE A | DATE: 3/11/04 | PART NO. #1448 | REV |
| APPROVED | SCALE | RELEASE DATE | WEIGHT | SHEET |

| REVISIONS | | | |
|-----------|-----|---------------|----------|
| ZONE | REV | FINISHES: | DATE |
| | | 605, 613, 626 | |
| | | | APPROVED |

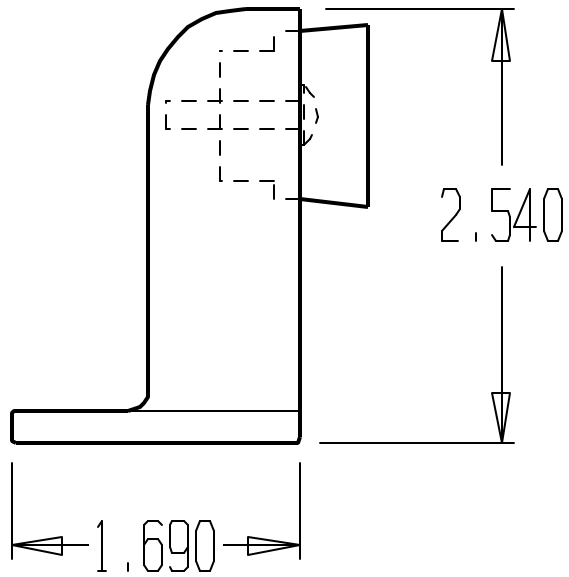

Ø .195
C'SINK FOR
#8 SCREW

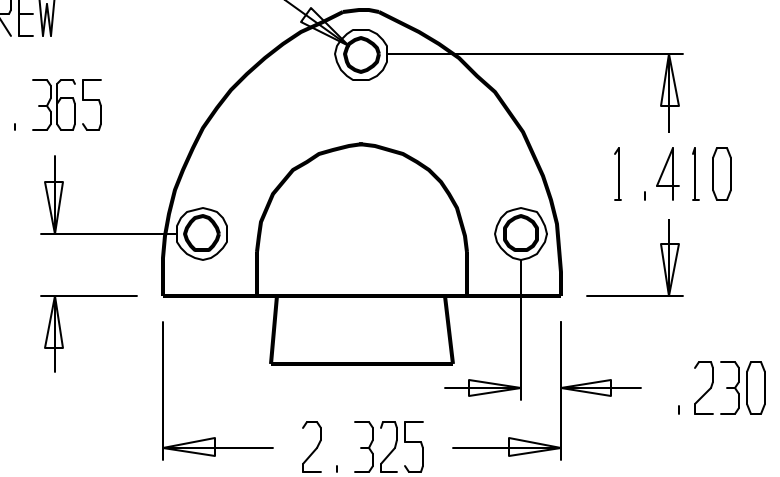

DON-JO MFG. INC.

| | | | | |
|----------|-------|--------------|----------|-------|
| DESIGNER | SIZE | DATE: | PART NO. | REV |
| | A | 3/11/04 | #1449 | |
| APPROVED | SCALE | RELEASE DATE | WEIGHT | SHEET |
| | | | | |

| REVISIONS | | | | |
|-----------|-----|-------------------------|------|----------|
| ZONE | REV | FINISHES: | DATE | APPROVED |
| | | 605, 613, 619, 620, 626 | | |

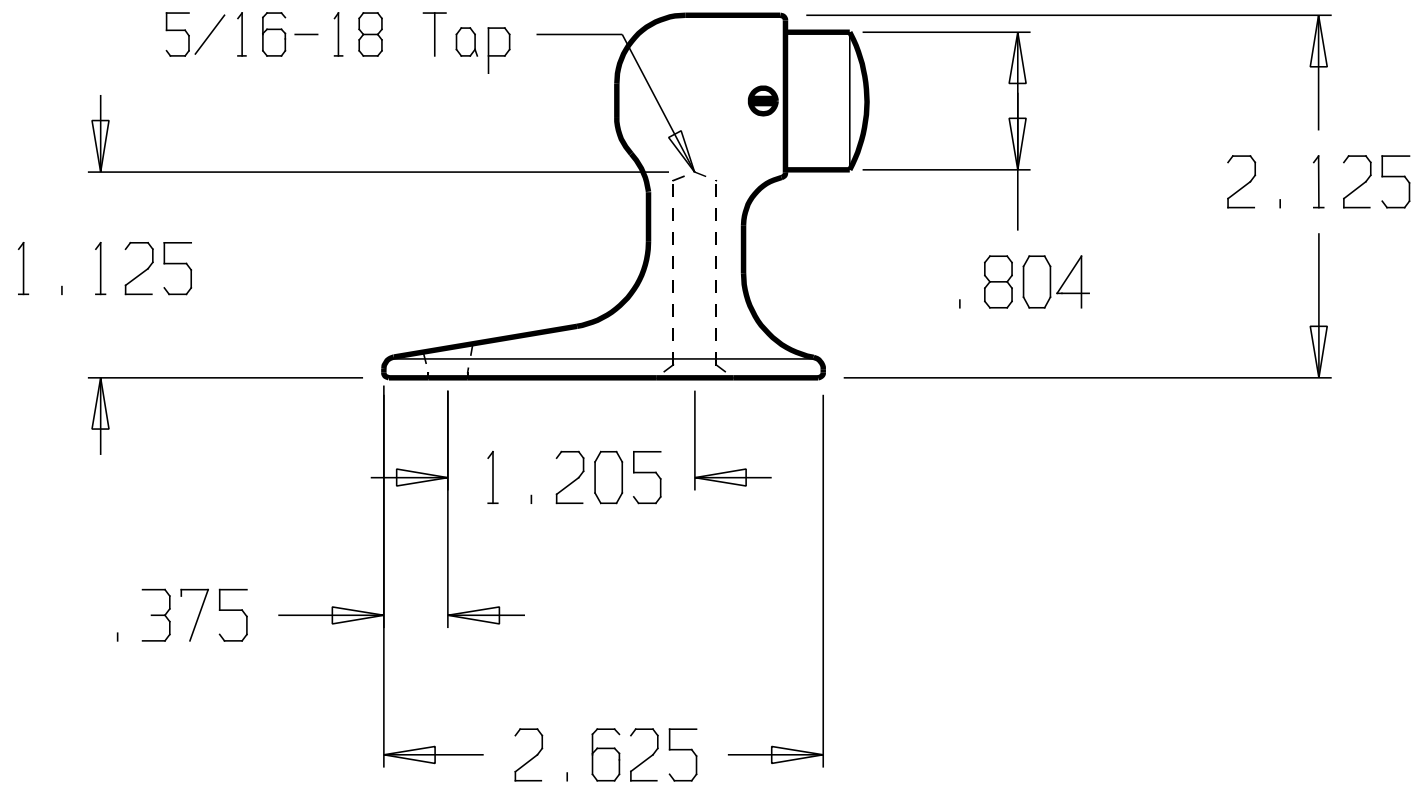

| | | | | | |
|------------------|--|-------|--------------|----------|-------|
| DON-JO MFG. INC. | | SIZE | DATE: | PART NO. | REV |
| DESIGNER | | A | 3/11/04 | #1450 | |
| APPROVED | | SCALE | RELEASE DATE | WEIGHT | SHEET |

| REVISIONS | | | |
|-----------|-----|---------------------|----------|
| ZONE | REV | FINISHES : | DATE |
| | | 605,613,619,620,626 | |
| | | | APPROVED |

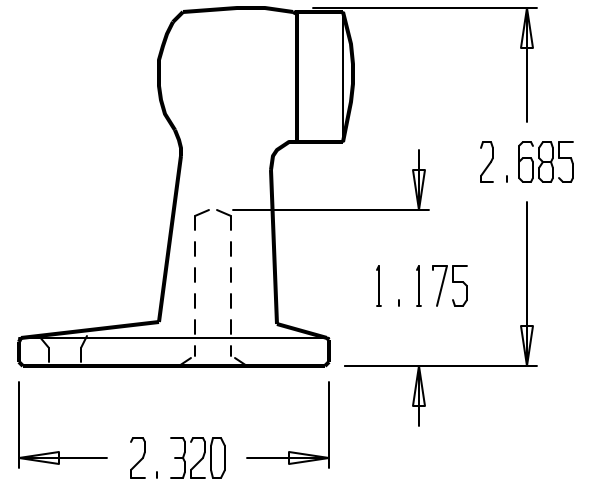
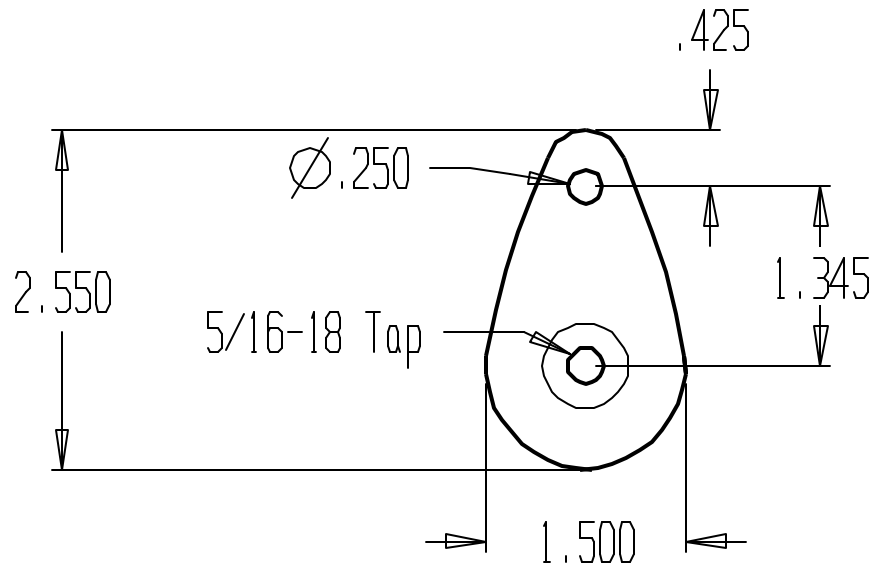

DON-JO MFG. INC.

DESIGNER
APPROVED

| | | | |
|-----------|------------------|-------------------|-------|
| SIZE A | DATE: 3/15/04 | PART NO. #1452 | REV |
| SCALE | RELEASE DATE | WEIGHT | SHEET |

| REVISIONS | | | |
|-----------|-----|-------------|----------|
| ZONE | REV | FINISHES : | DATE |
| | | 605,613,626 | |
| | | | APPROVED |

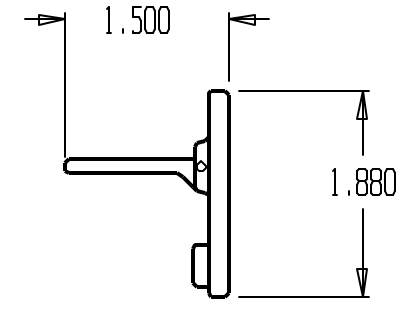
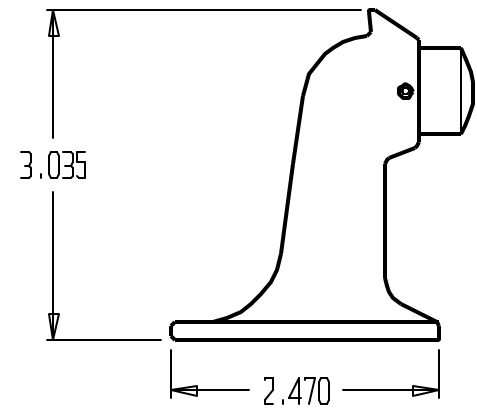
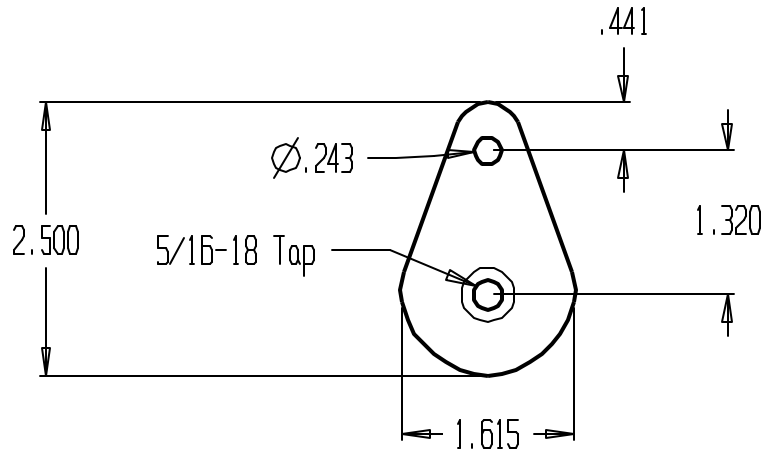

DON-JO MFG. INC.

| | | | | |
|----------|-------|--------------|----------|-------|
| DESIGNER | SIZE | DATE | PART NO. | REV |
| | A | 3/15/04 | #1453 | |
| APPROVED | SCALE | RELEASE DATE | WEIGHT | SHEET |

| REVISIONS | | | |
|-----------|-----|---------------------|----------|
| ZONE | REV | FINISHES: | DATE |
| | | 626, BP, BZ, CP, DU | |
| | | | APPROVED |

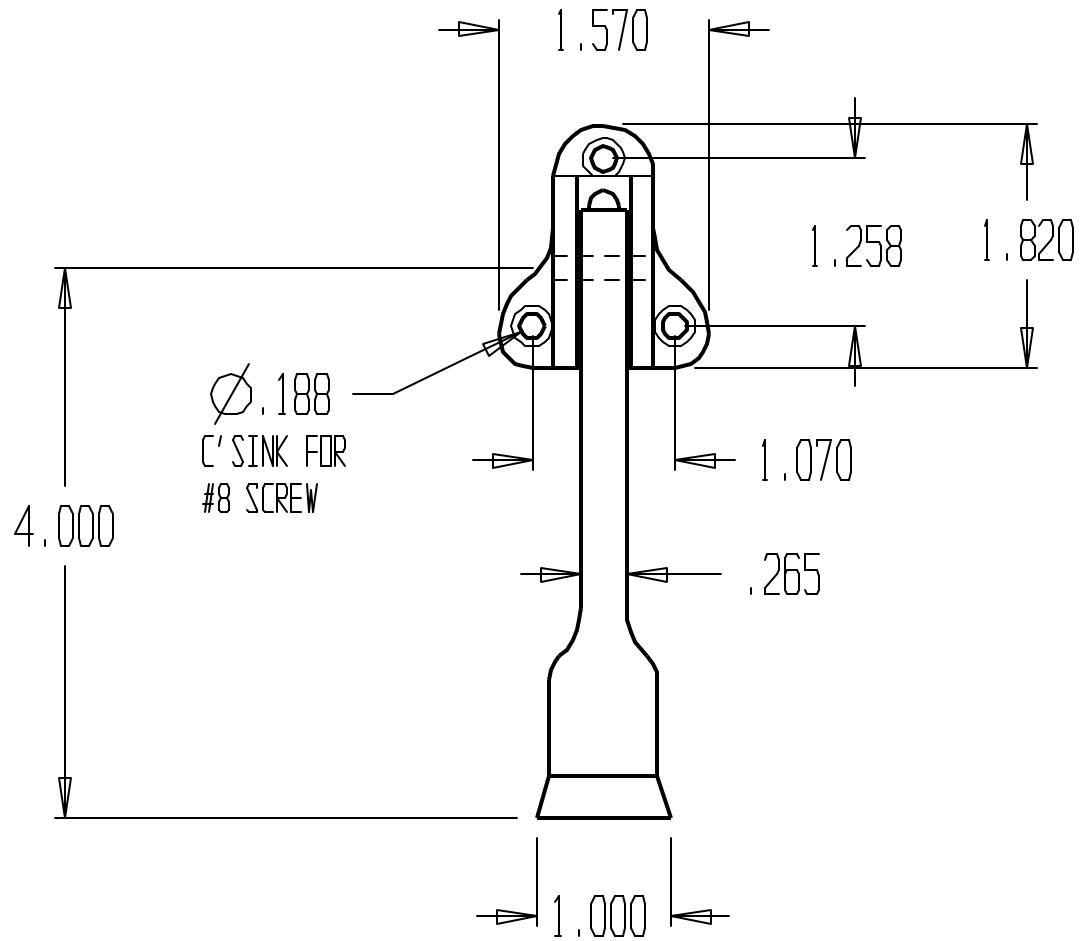

DON-JO MFG. INC.

| | |
|----------|--|
| DESIGNER | |
| APPROVED | |

| | | | |
|-----------|------------------|-------------------|-------|
| SIZE A | DATE: 3/15/04 | PART NO. #1455 | REV |
| SCALE | RELEASE DATE | WEIGHT | SHEET |

| REVISIONS | | | | |
|-----------|-----|------------|------|----------|
| ZONE | REV | MATERIAL : | DATE | APPROVED |
| | | 628 | | |

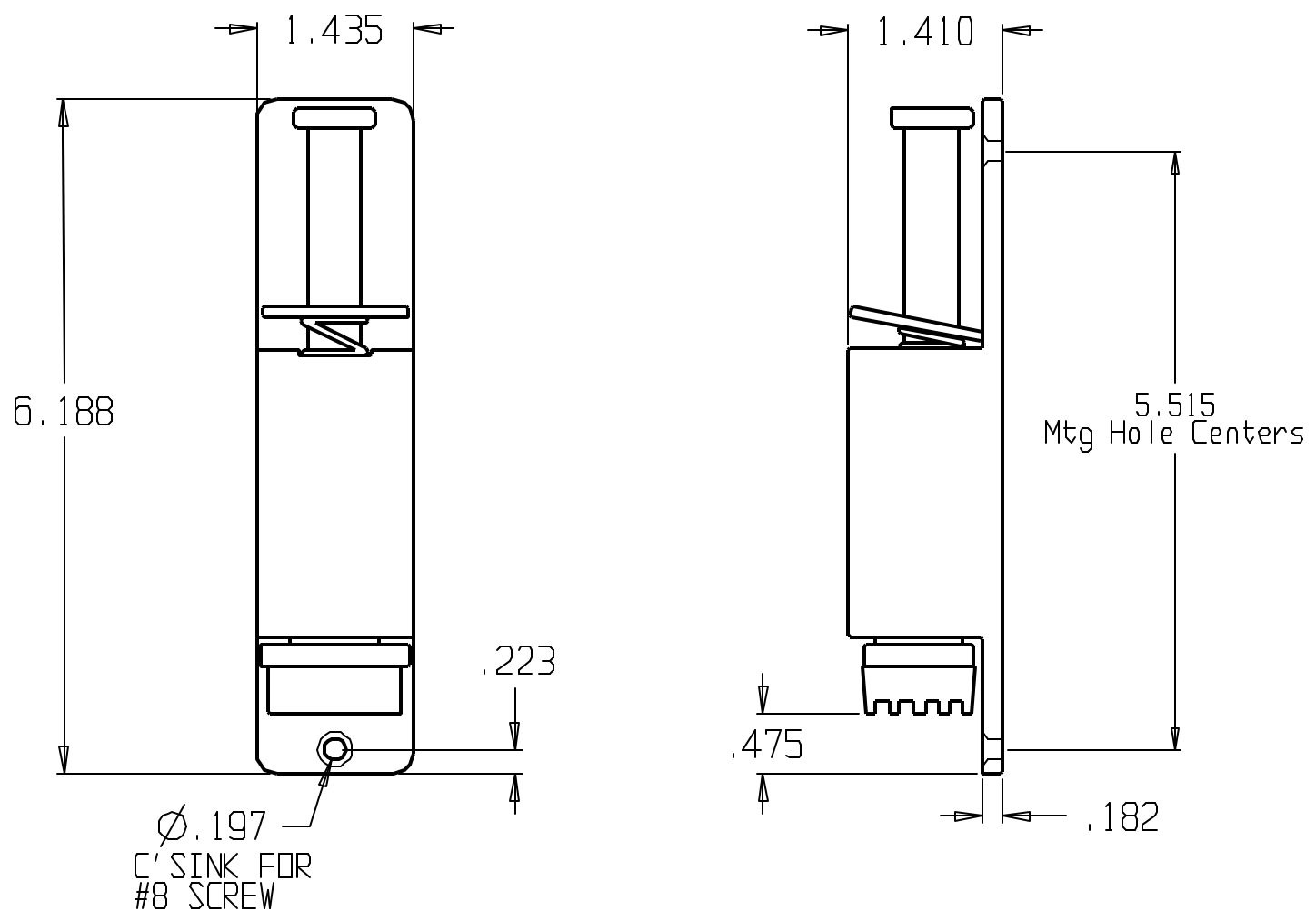

DON-JO MFG. INC.

| | | | | |
|----------|-----------|------------------|-------------------|-------|
| DESIGNER | SIZE A | DATE: 3/15/04 | PART NO. #1457 | REV |
| APPROVED | SCALE | RELEASE DATE | WEIGHT | SHEET |

| REVISIONS | | | | |
|-----------|-----|------------|------|----------|
| ZONE | REV | FINISHES : | DATE | APPROVED |
| | | BLACK | | |

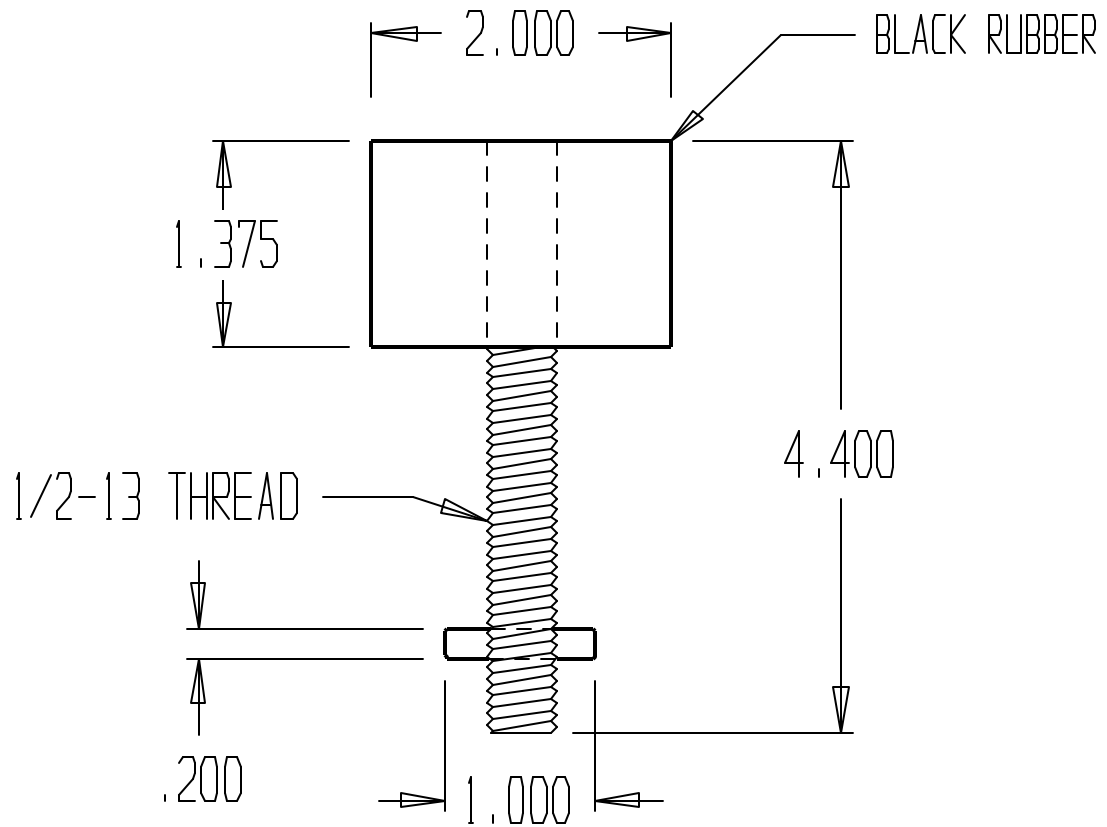

DON-JO MFG. INC.

| | | | | |
|----------|-----------|------------------|-------------------|-------|
| DESIGNER | SIZE A | DATE: 3/16/04 | PART NO. #1462 | REV |
| APPROVED | SCALE | RELEASE DATE | WEIGHT | SHEET |

| REVISIONS | | | |
|-----------|-----|------------|----------|
| ZONE | REV | FINISHES : | DATE |
| | | BLACK | |
| | | | APPROVED |

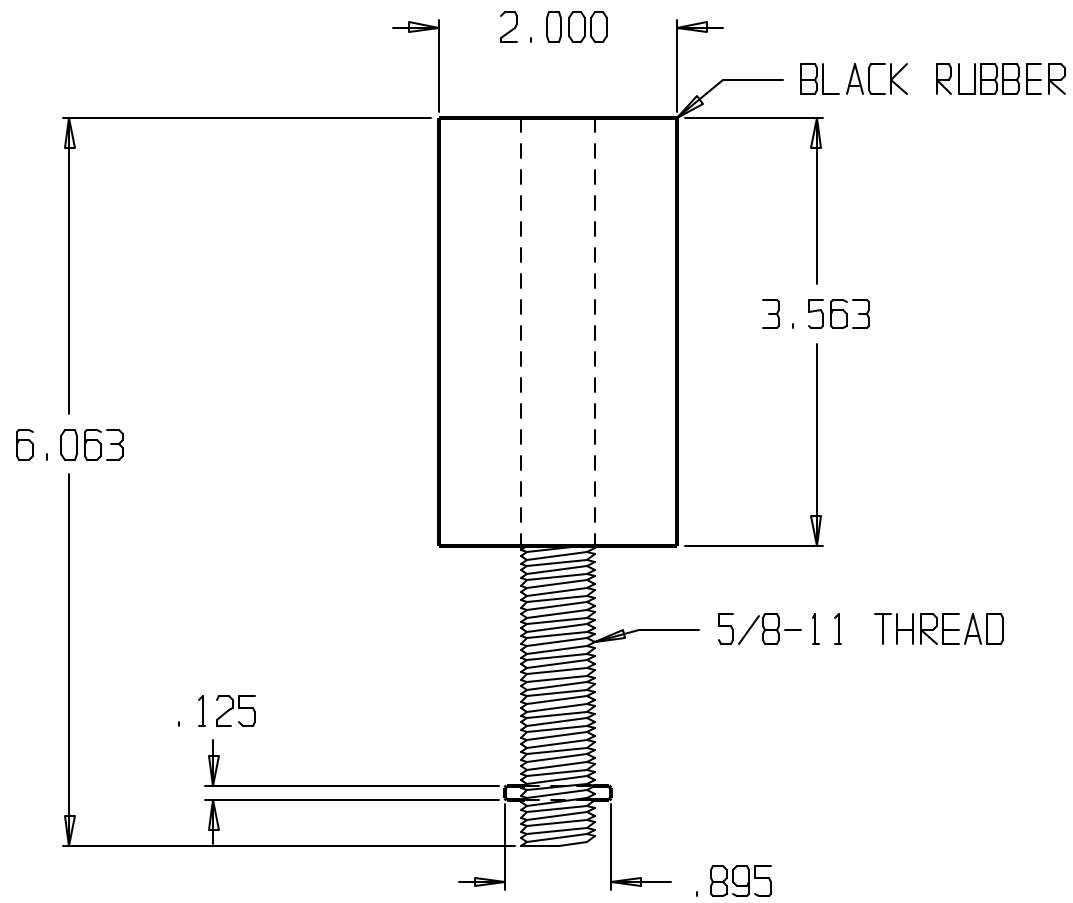

DON-JO MFG. INC.

| | |
|----------|--|
| DESIGNER | |
| APPROVED | |

| | | | |
|-------|--------------|----------|-------|
| SIZE | DATE | PART NO. | REV |
| A | 3/15/04 | #1463 | |
| SCALE | RELEASE DATE | WEIGHT | SHEET |

| REVISIONS | | | |
|-----------|-----|--------------------|----------|
| ZONE | REV | FINISHES: | DATE |
| | | 605, 613, 625, 626 | |
| | | | APPROVED |

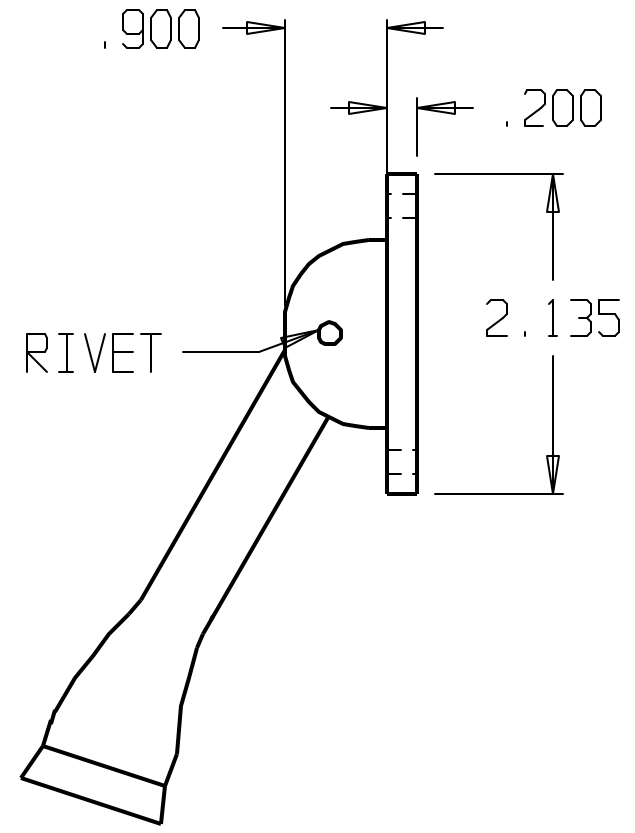
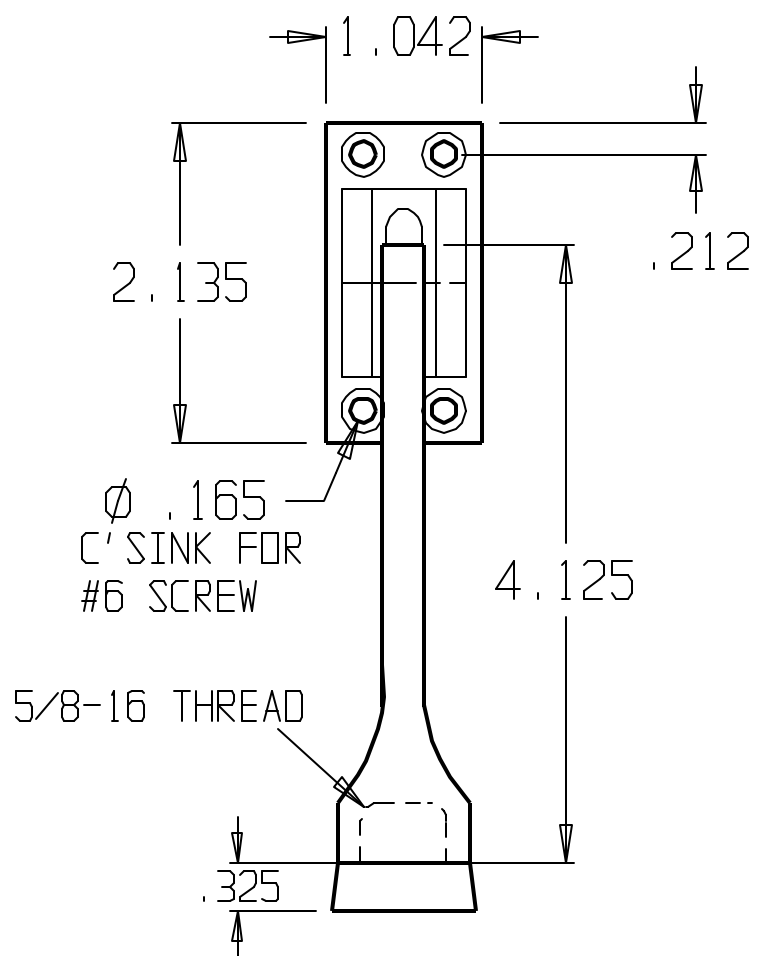

DON-JO MFG. INC.

| | | | | |
|----------|-------|--------------|----------|-------|
| DESIGNER | SIZE | DATE: | PART NO. | REV |
| | A | 3/16/04 | #1465 | |
| APPROVED | SCALE | RELEASE DATE | WEIGHT | SHEET |

| REVISIONS | | | APPROVED |
|-----------|-----|---|----------|
| ZONE | REV | FINISHES : | |
| | | SPRAYED BRASS, SPRAYED BRONZE, SPRAYED ALUMINUM | |

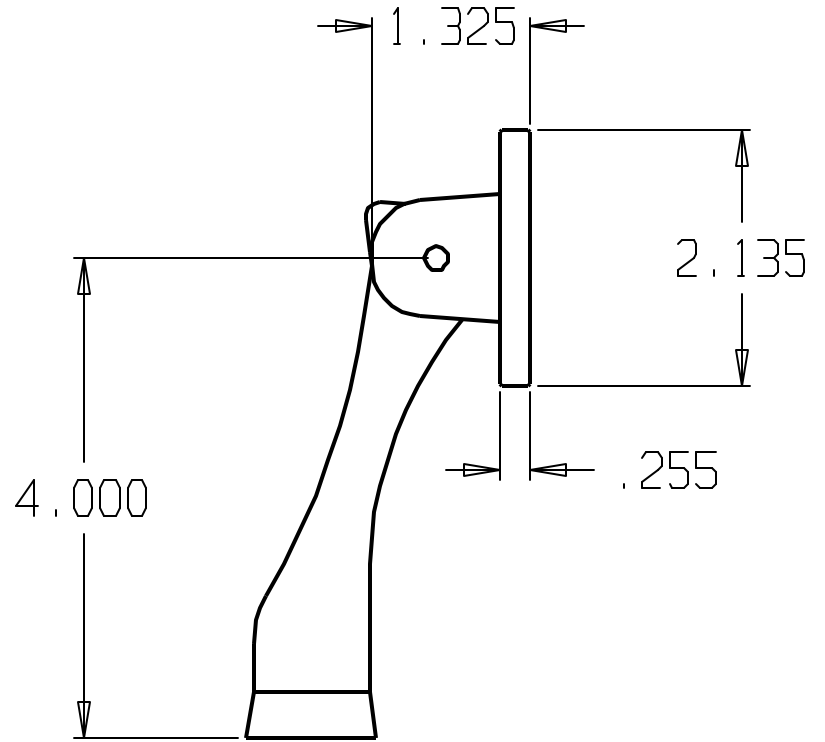
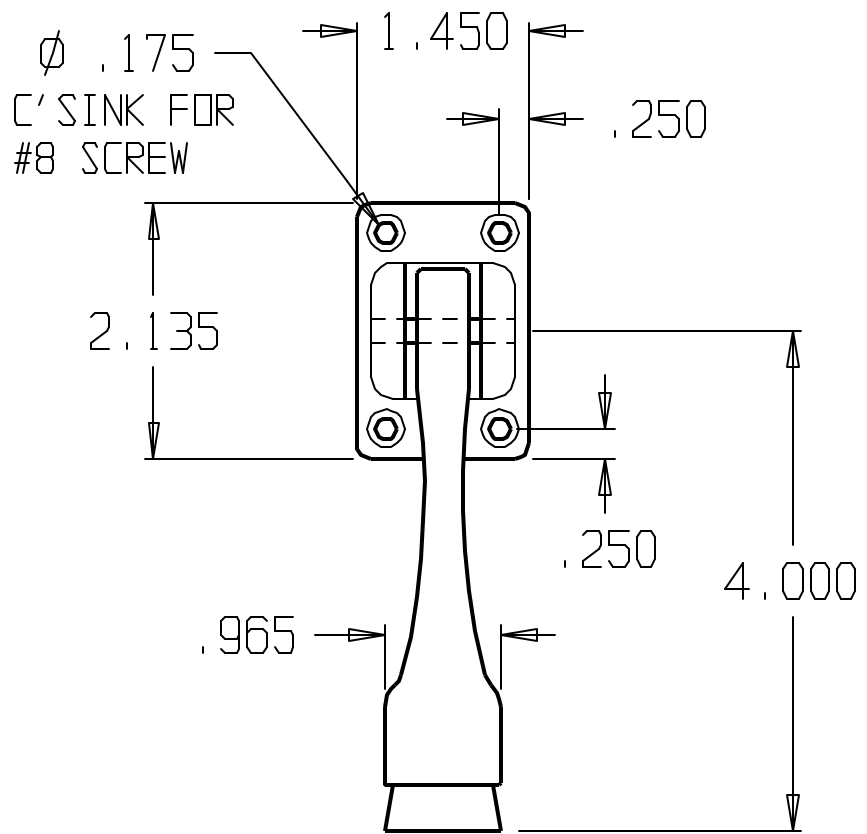

DON-JO MFG. INC.

DESIGNER
APPROVED

| | | | |
|-----------|------------------|-------------------|-------|
| SIZE A | DATE: 3/16/04 | PART NO. #1466 | REV |
| SCALE | RELEASE DATE | WEIGHT | SHEET |

| REVISIONS | | | |
|-----------|-----|-------------|----------|
| ZONE | REV | FINISHES : | DATE |
| | | 605,613,626 | |
| | | | APPROVED |

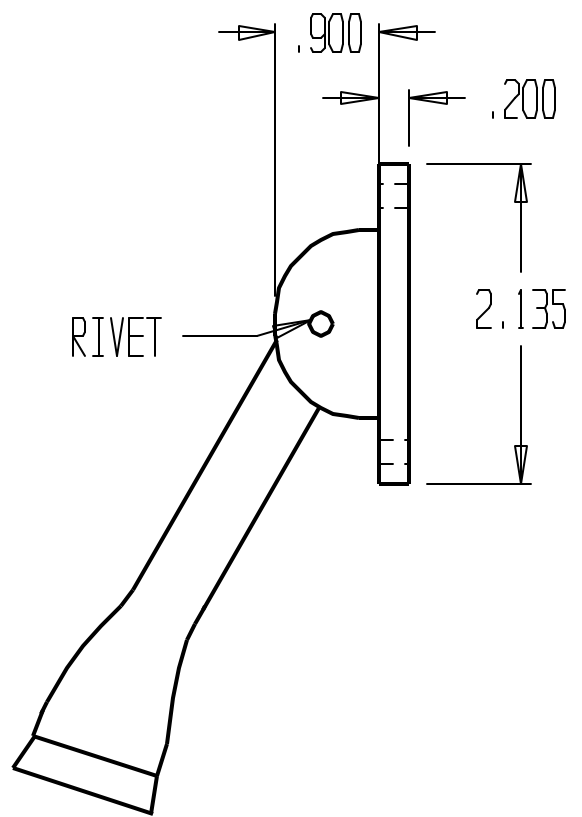
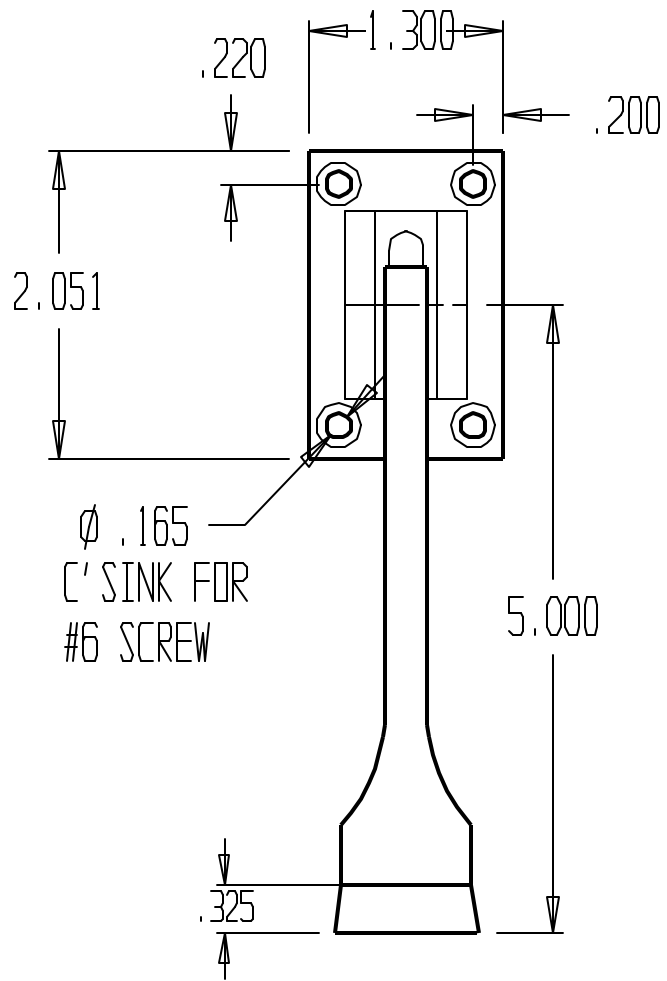

DON-JO MFG. INC.

| | | | | |
|----------|-----------|------------------|-------------------|-------|
| DESIGNER | SIZE A | DATE: 3/16/04 | PART NO. #1467 | REV |
| APPROVED | SCALE | RELEASE DATE | WEIGHT | SHEET |

| REVISIONS | | | | |
|-----------|-----|-------------|------|----------|
| ZONE | REV | FINISHES: | DATE | APPROVED |
| | | GRAY RUBBER | | |

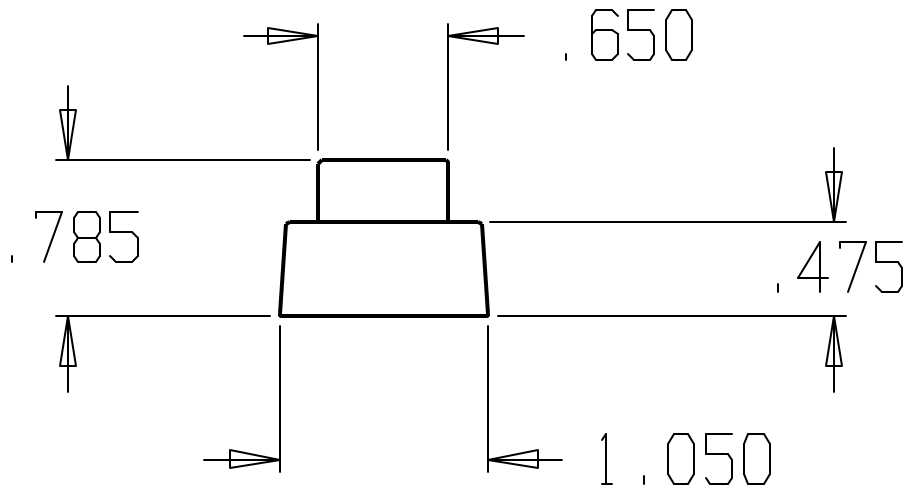

DON-JO MFG. INC.

| | | | | |
|----------|-------|--------------|----------|-------|
| DESIGNER | SIZE | DATE | PART NO. | REV |
| | A | 3/16/04 | #1469 | |
| APPROVED | SCALE | RELEASE DATE | WEIGHT | SHEET |
| | | | | |

| REVISIONS | | | | |
|-----------|-----|-------------|------|----------|
| ZONE | REV | FINISHES: | DATE | APPROVED |
| | | GRAY RUBBER | | |

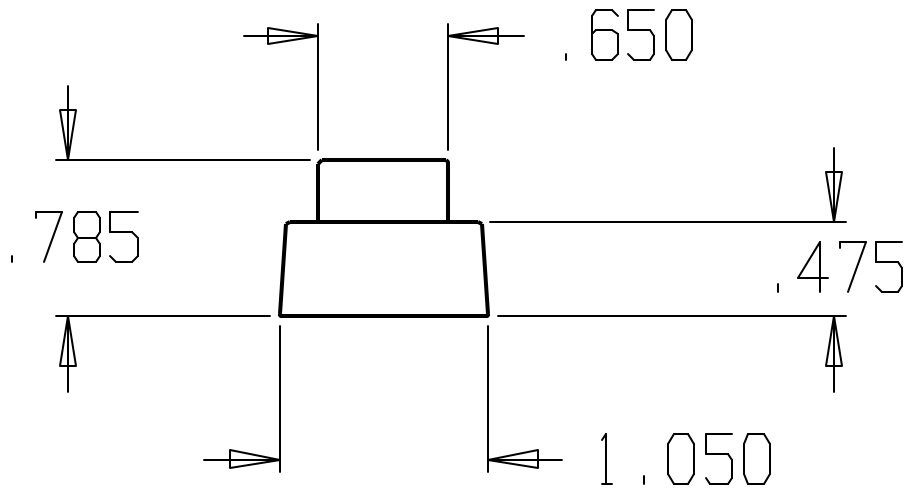

DON-JO MFG. INC.

| | | | | |
|----------|-------|--------------|----------|-------|
| DESIGNER | SIZE | DATE | PART NO. | REV |
| | A | 3/16/04 | #1469 | |
| APPROVED | SCALE | RELEASE DATE | WEIGHT | SHEET |
| | | | | |

| REVISIONS | | | | |
|-----------|-----|------------|------|----------|
| ZONE | REV | FINISHES : | DATE | APPROVED |
| | | | | |

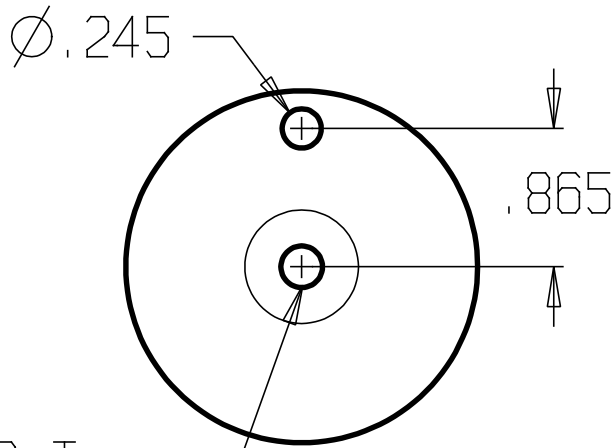

5/16-18 Tap

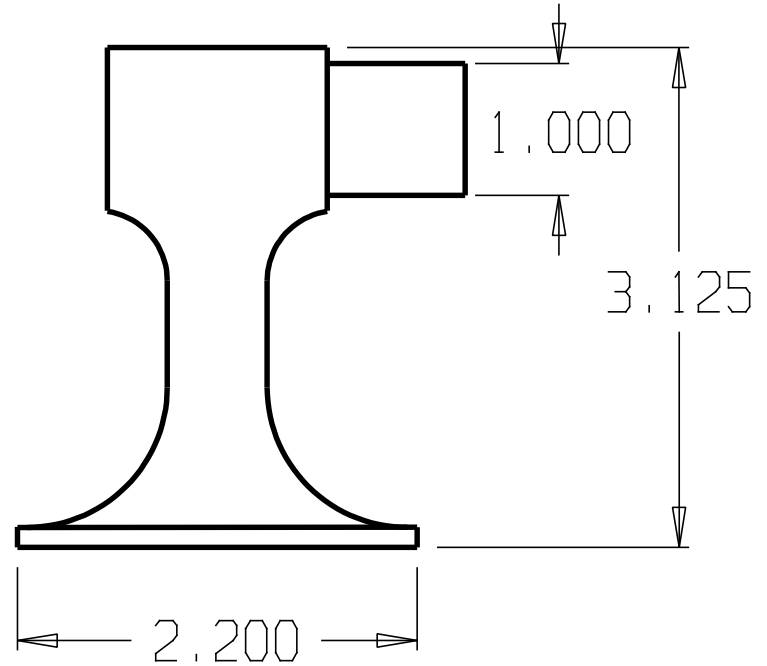

DON-JO MFG. INC.

DESIGNER
APPROVED

| | | | |
|-----------|-----------------|-------------------|-------|
| SIZE A | DATE 2/10/04 | PART NO. #1471 | REV |
| SCALE | RELEASE DATE | WEIGHT | SHEET |

| REVISIONS | | | |
|-----------|-----|-------------|----------|
| ZONE | REV | FINISHES: | DATE |
| | | 605,613,626 | |
| | | | APPROVED |

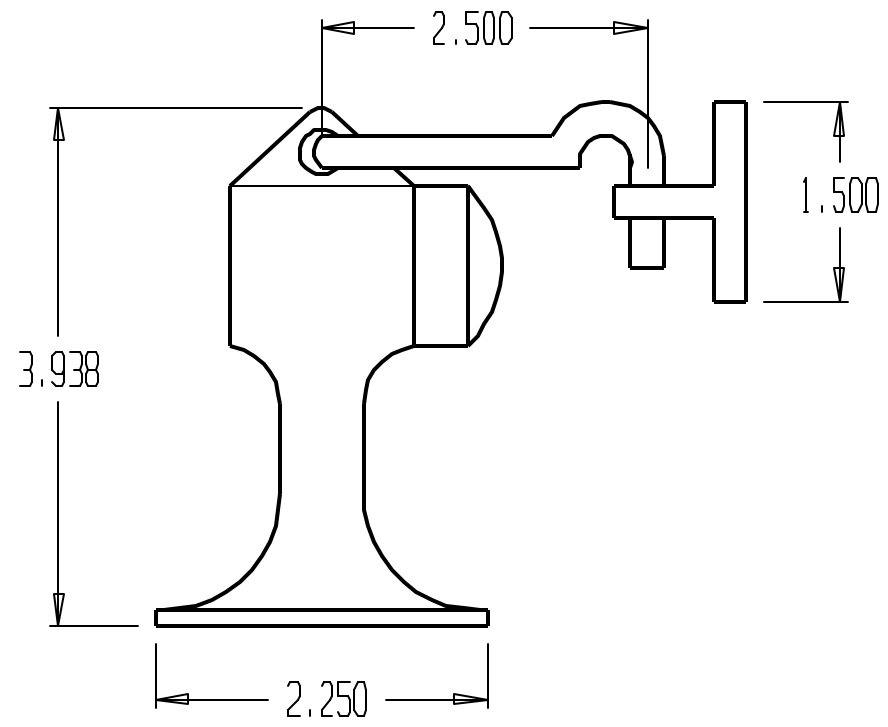
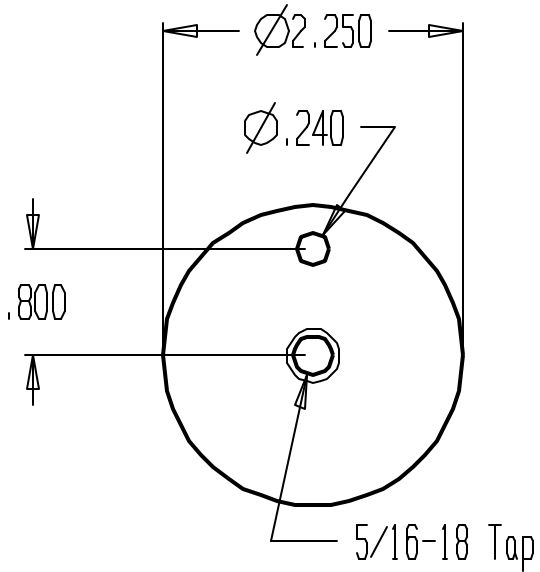

DON-JO MFG. INC.

| | | | | |
|----------|-----------|------------------|-------------------|-------|
| DESIGNER | SIZE A | DATE: 3/18/04 | PART NO. #1473 | REV |
| APPROVED | SCALE | RELEASE DATE | WEIGHT | SHEET |

| REVISIONS | | | | |
|-----------|-----|-------------|------|----------|
| ZONE | REV | FINISHES: | DATE | APPROVED |
| | | 605,613,626 | | |

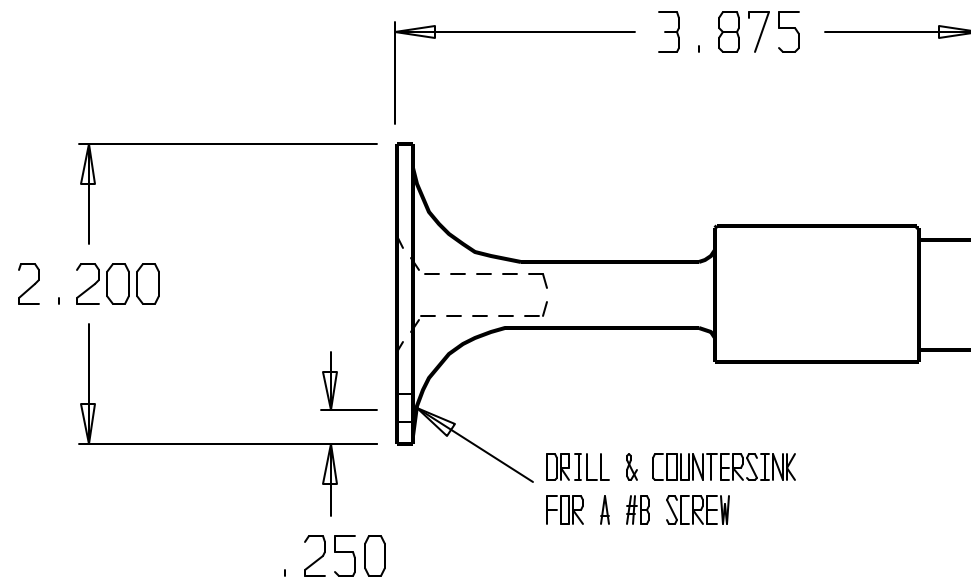
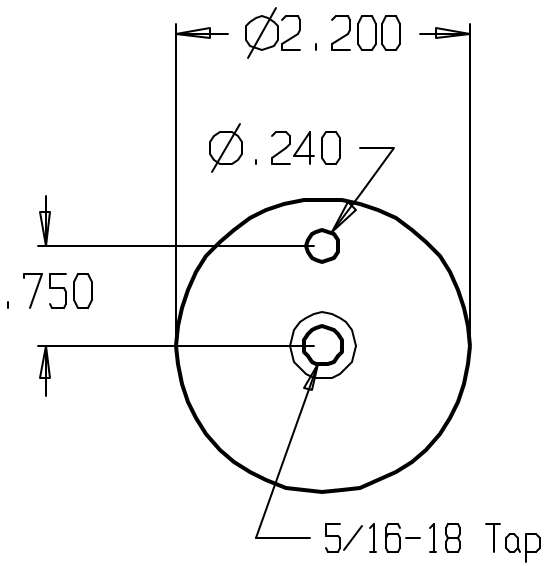

DON-JO MFG. INC.

| | | | | |
|----------|-----------|------------------|-------------------|-------|
| DESIGNER | SIZE A | DATE: 3/19/04 | PART NO. #1475 | REV |
| APPROVED | SCALE | RELEASE DATE | WEIGHT | SHEET |

| REVISIONS | | | |
|-----------|-----|---------------|----------|
| ZONE | REV | FINISHES : | DATE |
| | | 605, 613, 626 | |
| | | | APPROVED |

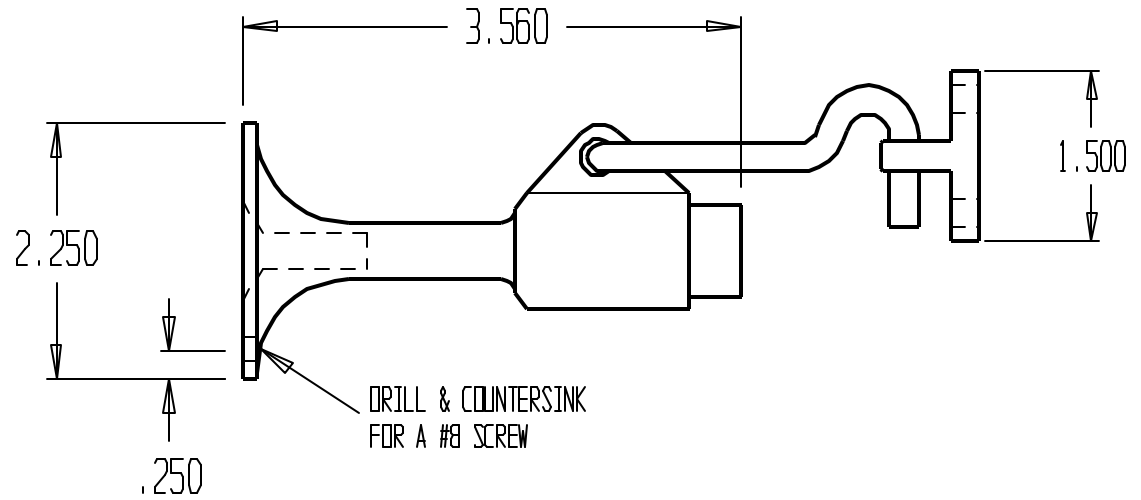
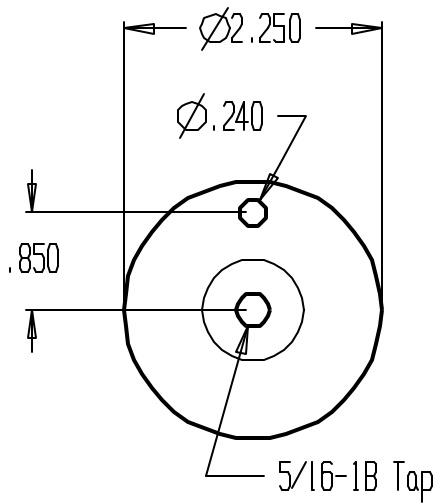

DON-JO MFG. INC.

| | | | | |
|----------|-----------|-----------------|-------------------|-------|
| DESIGNER | SIZE A | DATE 3/19/04 | PART NO. #1477 | REV |
| APPROVED | SCALE | RELEASE DATE | WEIGHT | SHEET |

| REVISIONS | | | |
|-----------|-----|------------|----------|
| ZONE | REV | FINISHES : | DATE |
| | | 626 | |
| | | | APPROVED |

C' SINK FOR
1/4" SCREWS

.205

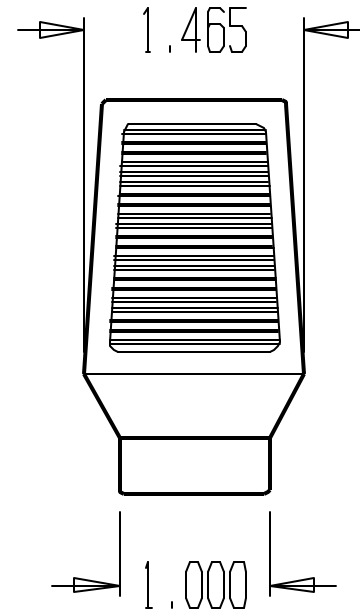
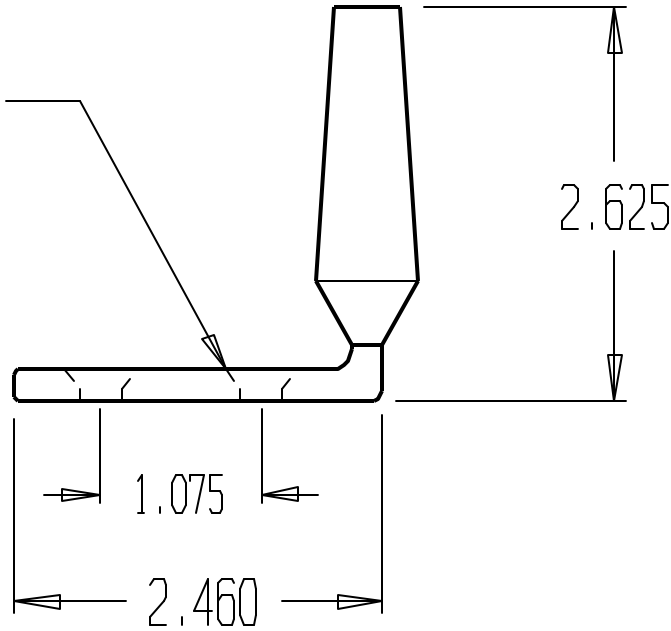

DON-JO MFG. INC.

DESIGNER
APPROVED

SIZE
A

DATE:
3/19/04

PART NO.
#1480

REV

SCALE RELEASE DATE WEIGHT SHEET

| REVISIONS | | | |
|-----------|-----|-------------|----------|
| ZONE | REV | FINISHES : | DATE |
| | | 605,613,626 | |
| | | | APPROVED |

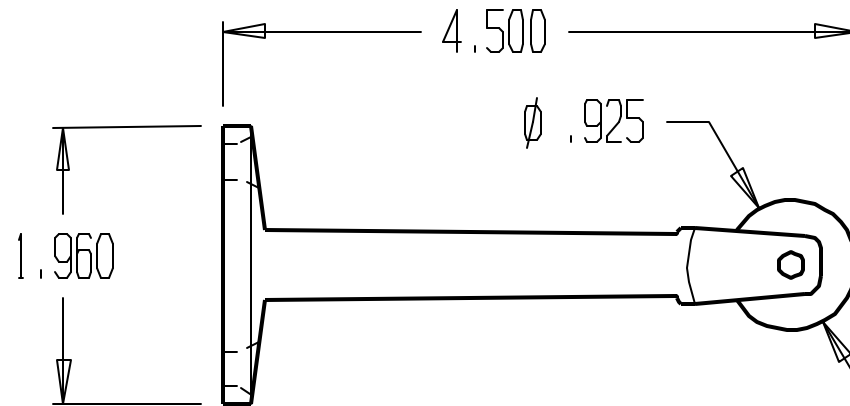
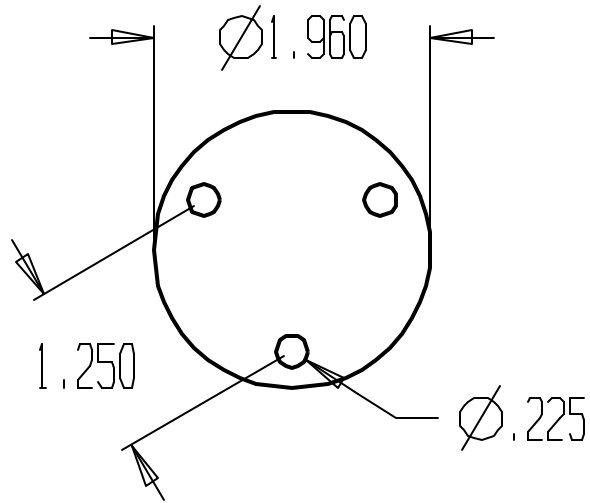

DON-JO MFG. INC.

| | | | | |
|----------|-------|--------------|----------|-------|
| DESIGNER | SIZE | DATE: | PART NO. | REV |
| | A | 3/12/04 | #1486 | |
| APPROVED | SCALE | RELEASE DATE | WEIGHT | SHEET |
| | | | | |

| REVISIONS | | | |
|-----------|-----|-------------|------|
| ZONE | REV | FINISHES : | DATE |
| | | 605,613,626 | |
| | | APPROVED | |

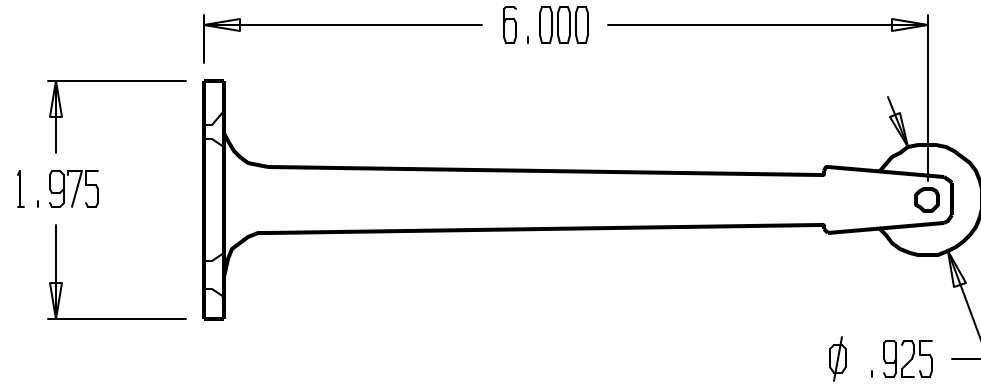
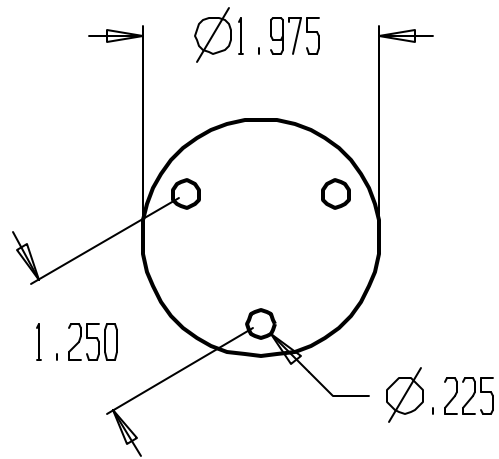

DON-JO MFG. INC.

| | | | | |
|----------|-------|--------------|----------|-------|
| DESIGNER | SIZE | DATE: | PART NO. | REV |
| | A | 3/11/04 | #1487 | |
| APPROVED | SCALE | RELEASE DATE | WEIGHT | SHEET |

| REVISIONS | | | |
|-----------|-----|-------------|----------|
| ZONE | REV | FINISHES: | DATE |
| | | 605,613,626 | APPROVED |

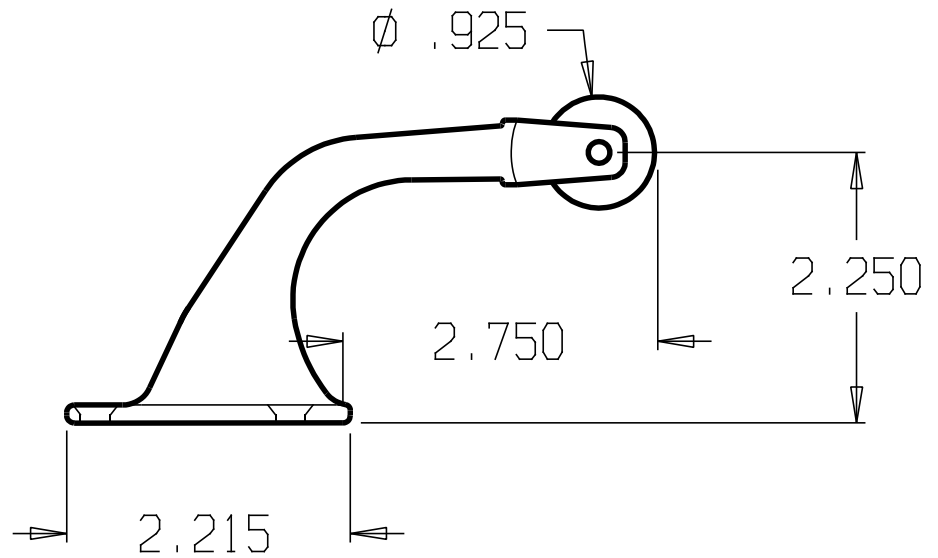
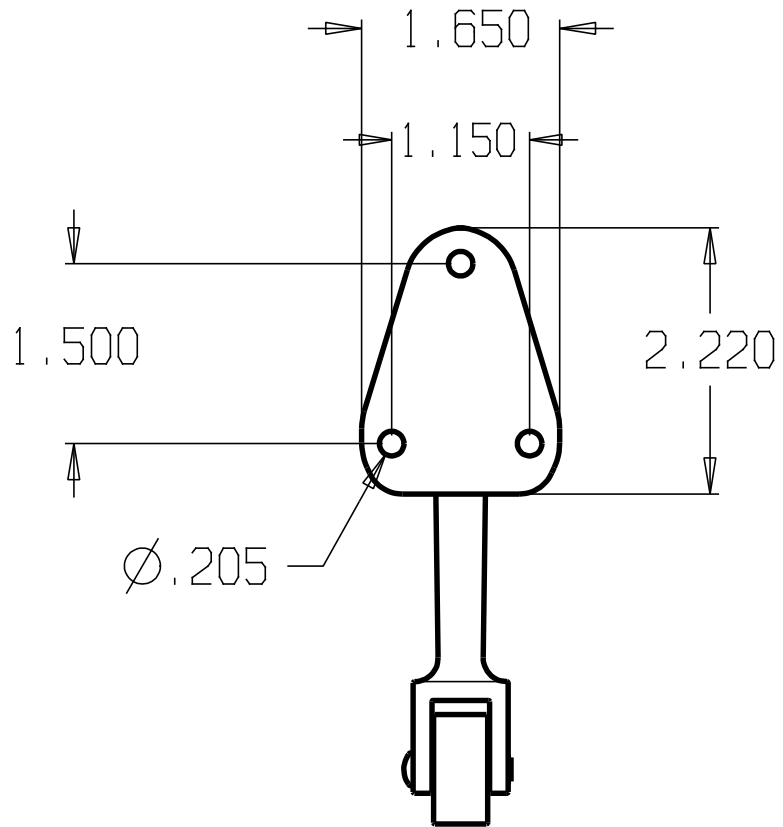

DON-JO MFG. INC.

| | | | | |
|----------|-------|--------------|----------|-------|
| DESIGNER | SIZE | DATE: | PART NO. | REV |
| | A | 3/11/04 | #1488 | |
| APPROVED | SCALE | RELEASE DATE | WEIGHT | SHEET |

| REVISIONS | | | | |
|-----------|-----|-------------|------|----------|
| ZONE | REV | FINISHES: | DATE | APPROVED |
| | | 605,613,626 | | |

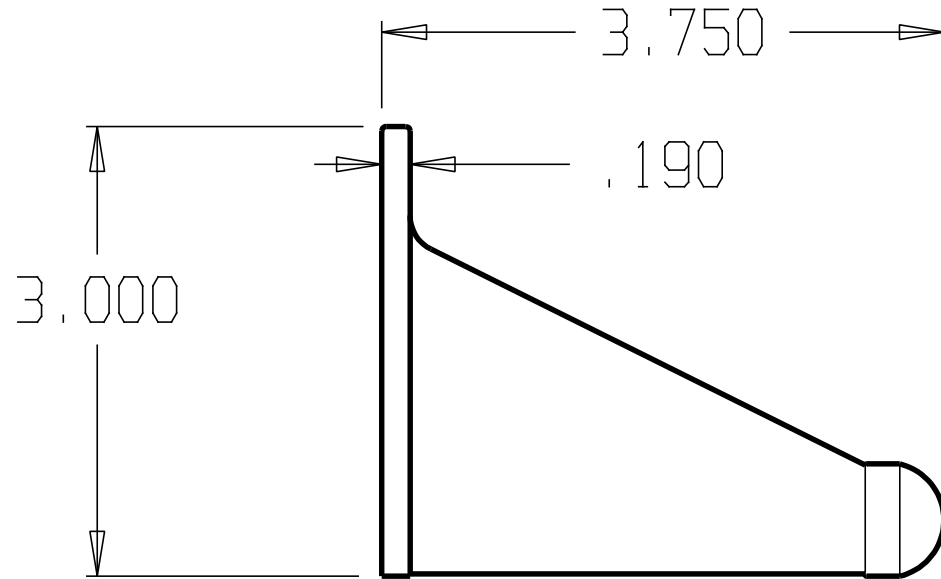
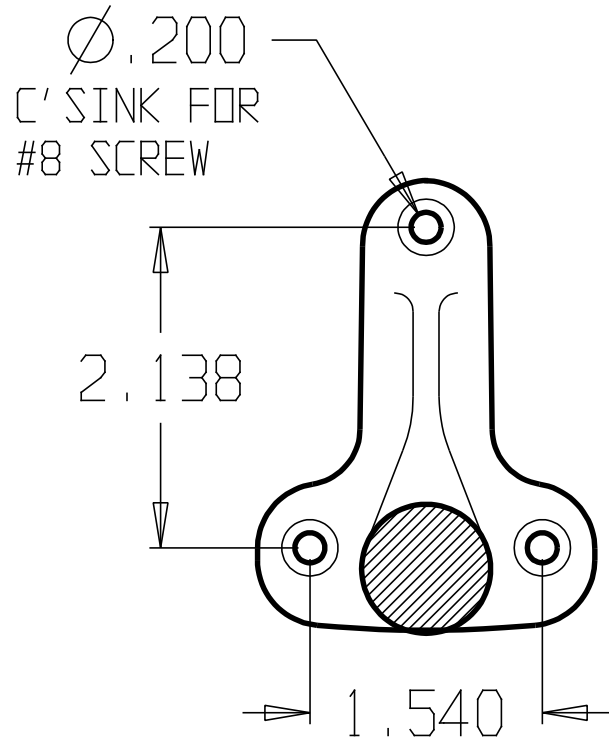

DON-JO MFG. INC.

| | | | | |
|----------|-----------|------------------|-------------------|-------|
| DESIGNER | SIZE A | DATE: 3/23/04 | PART NO. #1492 | REV |
| APPROVED | SCALE | RELEASE DATE | WEIGHT | SHEET |

| REVISIONS | | | |
|-----------|-----|-----------|----------|
| ZONE | REV | FINISHES: | DATE |
| | | 626 | |
| | | | APPROVED |

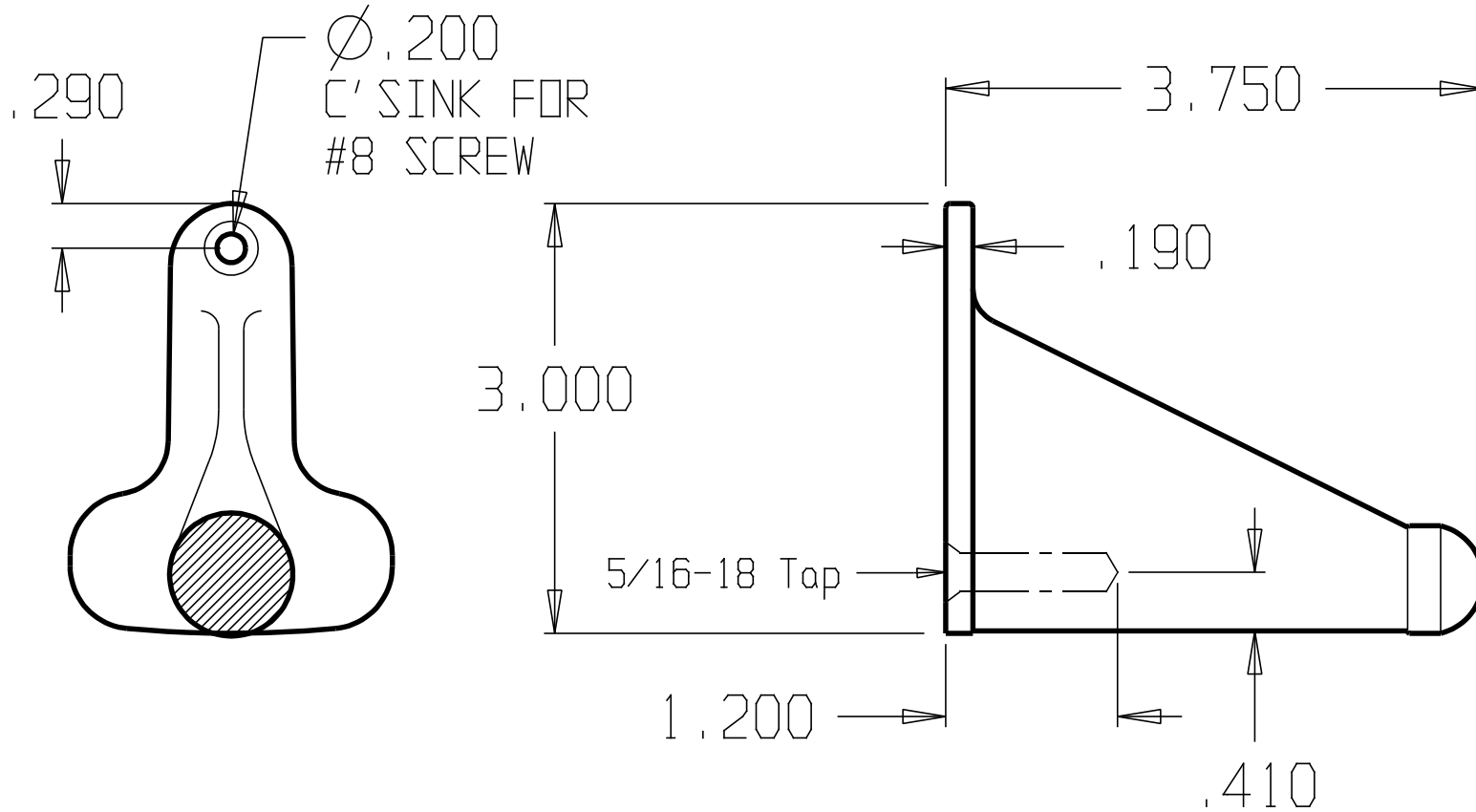

| | | | | | | | |
|------------------|--|-------|--------------|--------|-------|----------|-----|
| DON-JO MFG. INC. | | | | SIZE | DATE: | PART NO. | REV |
| DESIGNER | | A | 3/23/04 | #1492 | | | |
| APPROVED | | SCALE | RELEASE DATE | WEIGHT | SHEET | | |

| REVISIONS | | | | |
|-----------|-----|-----------------|------|----------|
| ZONE | REV | FINISHES: | DATE | APPROVED |
| | | 605,619,620,625 | | |

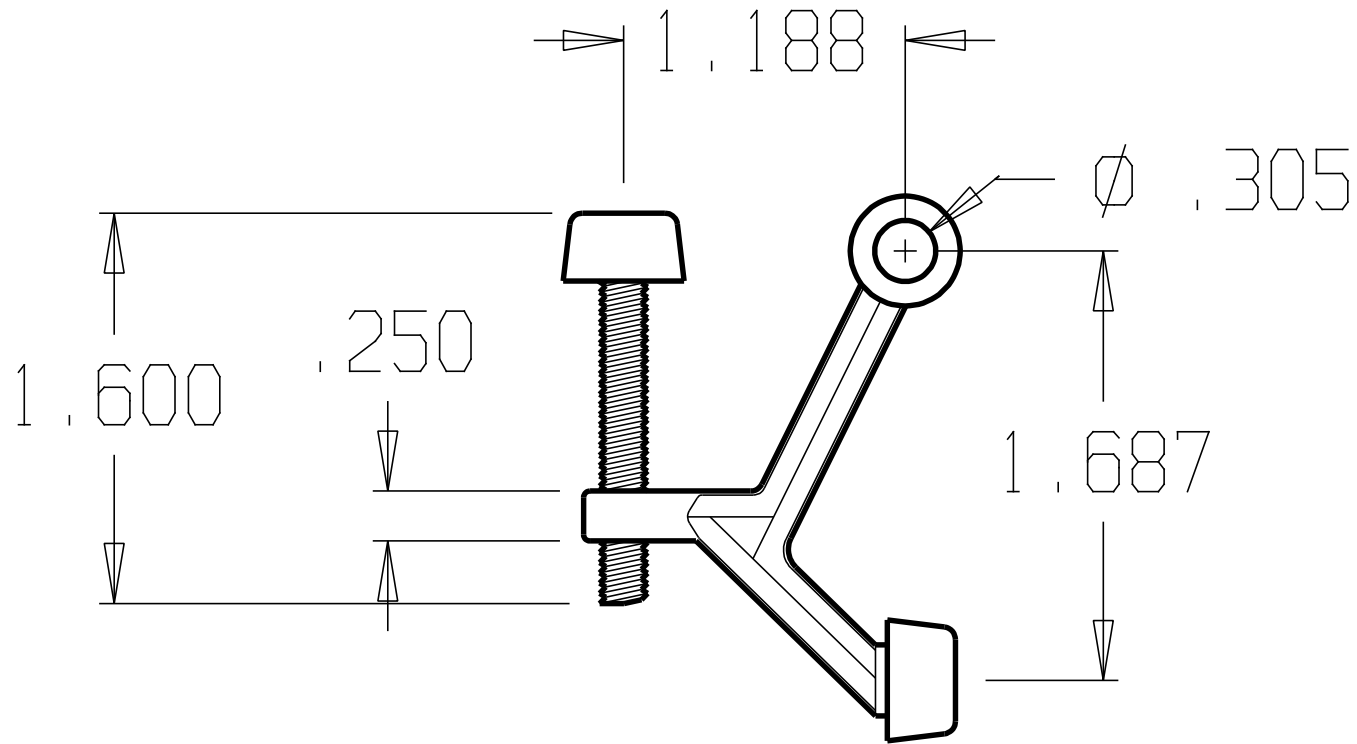

DON-JO MFG. INC.

| | | | | |
|----------|-----------|------------------|-------------------|-------|
| DESIGNER | SIZE A | DATE: 3/23/04 | PART NO. #1500 | REV |
| APPROVED | SCALE | RELEASE DATE | WEIGHT | SHEET |

| REVISIONS | | | | |
|-----------|-----|---------------|------|----------|
| ZONE | REV | FINISHES: | DATE | APPROVED |
| | | 605, 609, 625 | | |

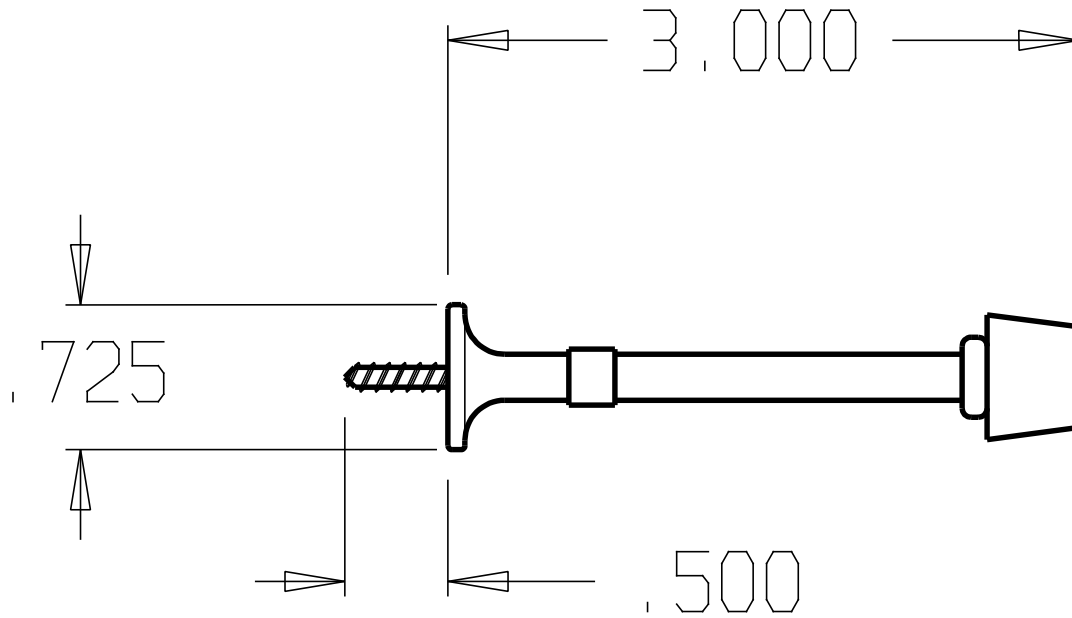

DON-JO MFG. INC.

| | |
|----------|--|
| DESIGNER | |
| APPROVED | |

| | | | |
|-------|--------------|----------|-------|
| SIZE | DATE: | PART NO. | REV |
| A | 3/23/04 | #1501 | |
| SCALE | RELEASE DATE | WEIGHT | SHEET |

| REVISIONS | | | | |
|-----------|-----|-------------------------|------|----------|
| ZONE | REV | FINISHES: | DATE | APPROVED |
| | | 605, 613, 619, 620, 626 | | |

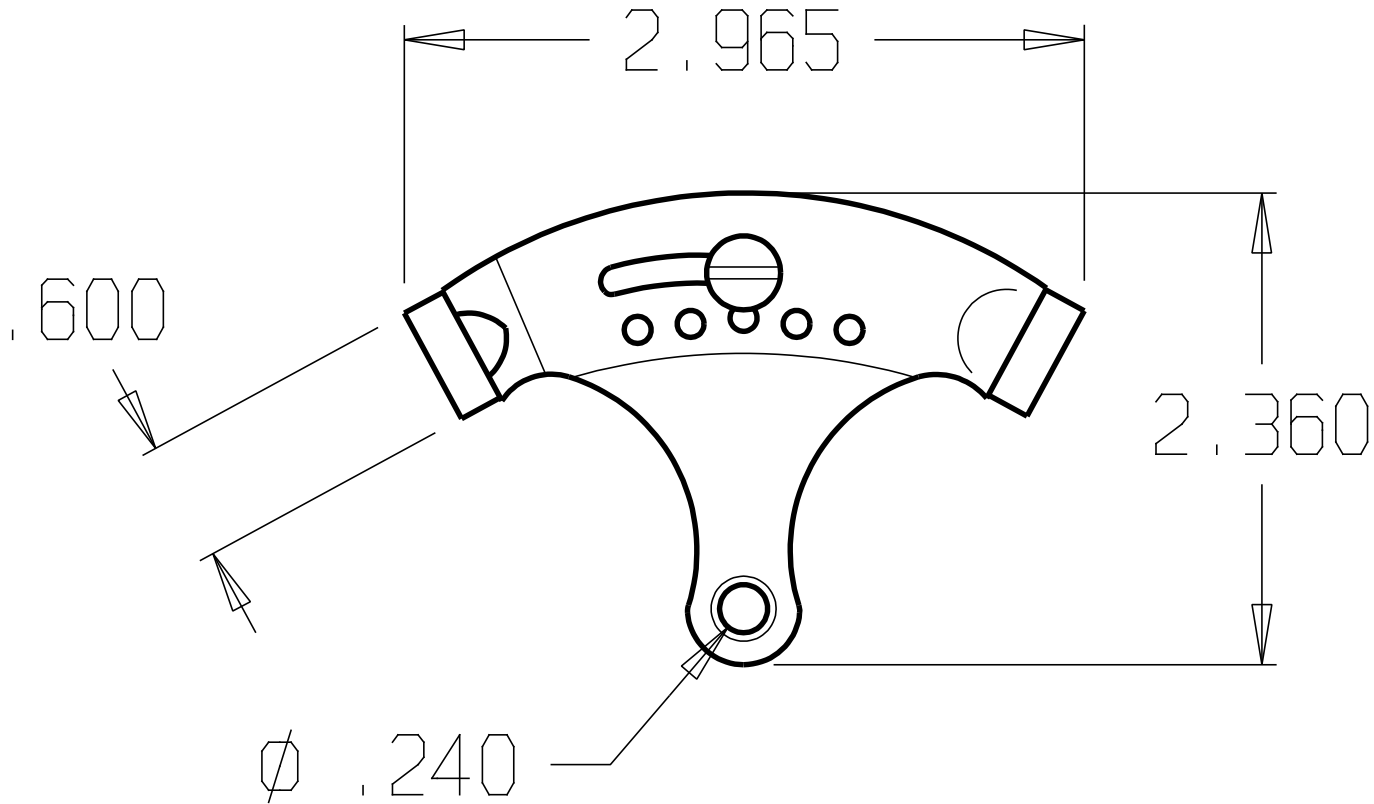

DON-JO MFG. INC.

| | |
|----------|--|
| DESIGNER | |
| APPROVED | |

| | | | |
|-------|--------------|----------|-------|
| SIZE | DATE: | PART NO. | REV |
| A | 3/23/04 | #1502 | |
| SCALE | RELEASE DATE | WEIGHT | SHEET |

DWG NO

SH

REV

REVISIONS

ZONE

REV

FINISHES:

605, 609, 619, 620, 625

DATE

APPROVED

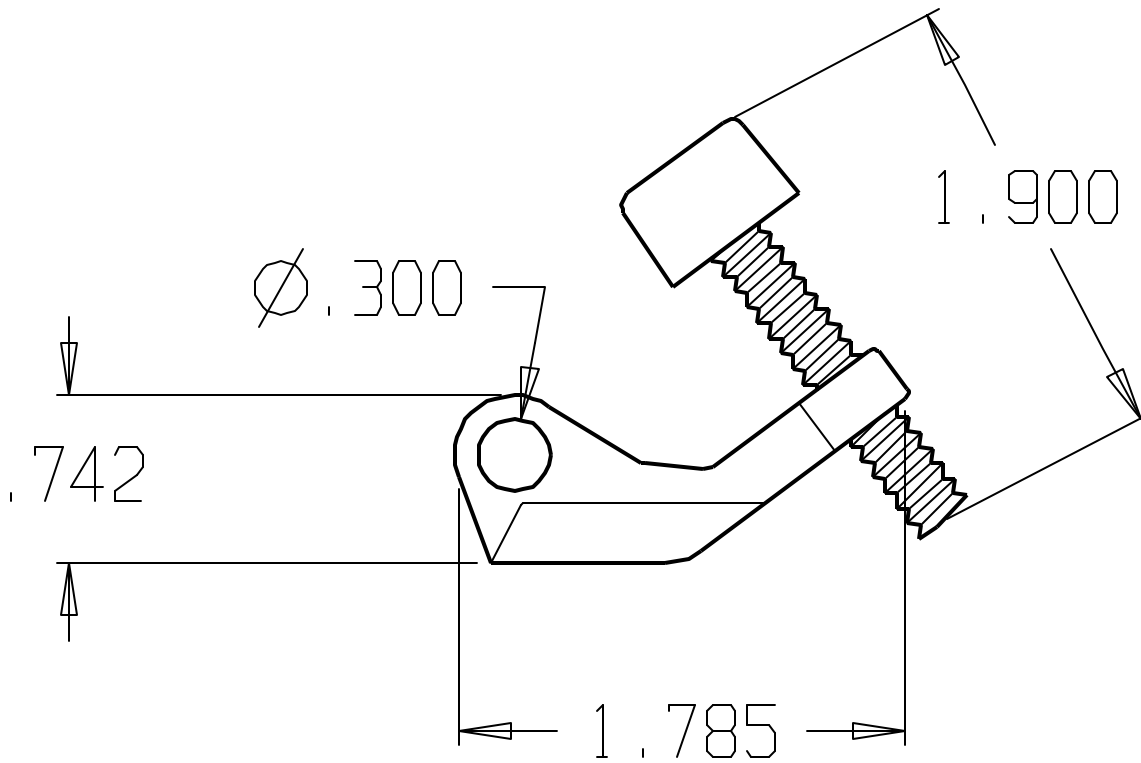

DON-JO MFG. INC.

DESIGNER

APPROVED

SIZE

A

DATE:

3/23/04

PART NO.

#1503

REV

SCALE

RELEASE DATE

WEIGHT

SHEET

| REVISIONS | | | | |
|-----------|-----|-------------------------|------|----------|
| ZONE | REV | FINISHES: | DATE | APPROVED |
| | | 605,613,619,620,625,626 | | |

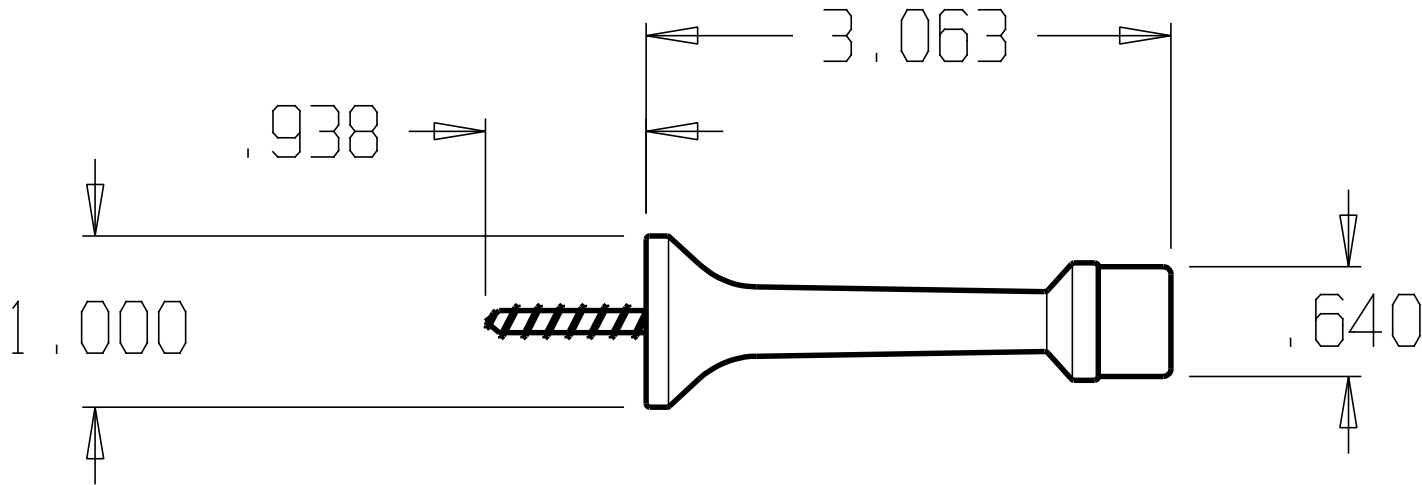

| | | | | |
|-------------------------|-----------|------------------|-------------------|-------|
| DON-JO MFG. INC. | | | | |
| DESIGNER | SIZE A | DATE: 3/23/04 | PART NO. #1504 | REV |
| APPROVED | SCALE | RELEASE DATE | WEIGHT | SHEET |

| | | |
|--------|----|-----|
| DWG NO | SH | REV |
|--------|----|-----|

| REVISIONS | | |
|-----------|-----|---|
| ZONE | REV | FINISHES: 605, 609, 613, 619, 620, 622, 626 |
| | | GAUGE: |

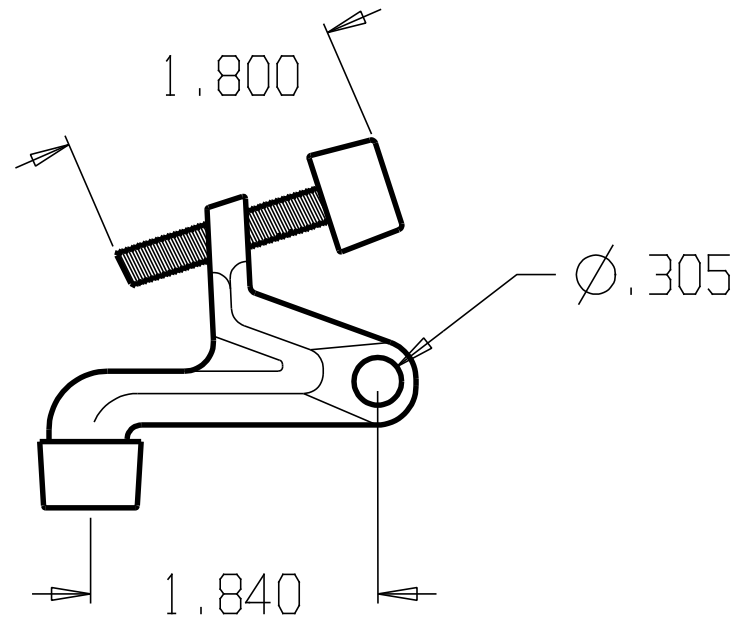

| | | | | | |
|------------------|------|-------|--------------|----------|-------|
| DON-JO MFG. INC. | | SIZE | DATE: | PART NO. | REV |
| DESIGNER | D.R. | A | 10/25/05 | #1505 | |
| | | SCALE | RELEASE DATE | WEIGHT | SHEET |

| REVISIONS | | | | |
|-----------|-----|-------------------------|------|----------|
| ZONE | REV | FINISHES : | DATE | APPROVED |
| | | 605,613,619,620,625,626 | | |

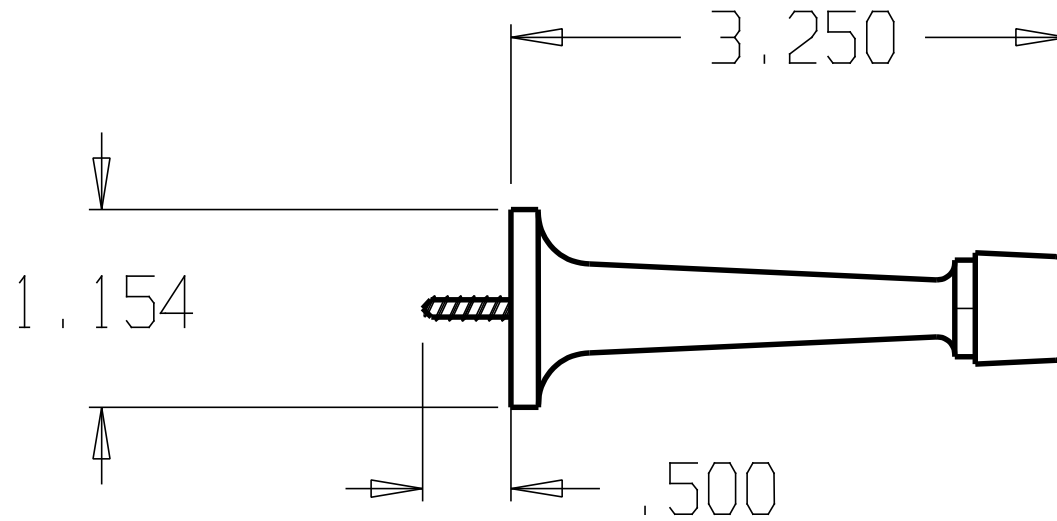

DON-JO MFG. INC.

| | | | | |
|----------|-------|--------------|----------|-------|
| DESIGNER | SIZE | DATE: | PART NO. | REV |
| | A | 3/23/04 | #1506 | |
| APPROVED | SCALE | RELEASE DATE | WEIGHT | SHEET |
| | | | | |

| | | |
|--------|----|-----|
| DWG NO | SH | REV |
|--------|----|-----|

| REVISIONS | | | | |
|-----------|-----|-------------------------|------|----------|
| ZONE | REV | FINISHES: | DATE | APPROVED |
| | | 605, 609, 619, 620, 625 | | |

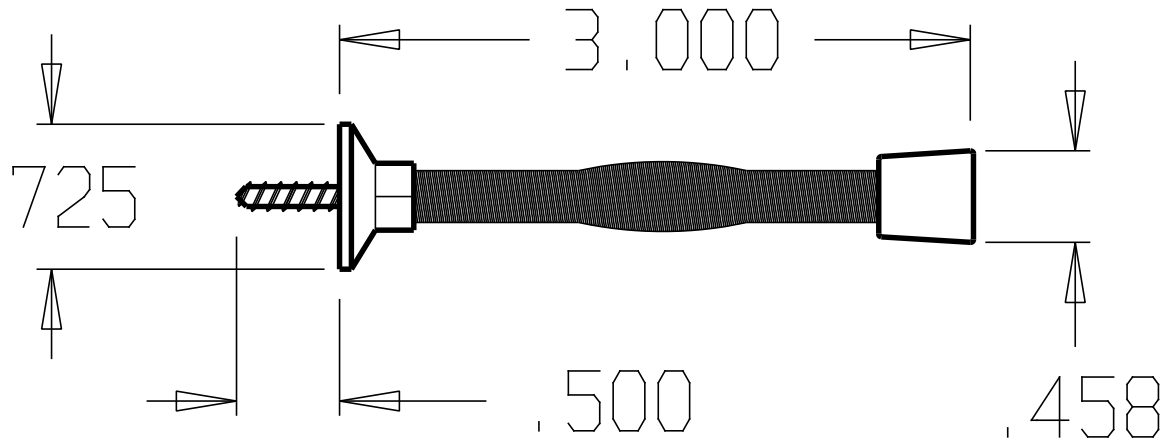

| | | | | | |
|------------------|--|-------|--------------|----------|-------|
| DON-JO MFG. INC. | | SIZE | DATE: | PART NO. | REV |
| DESIGNER | | A | 3/23/04 | #1508 | |
| APPROVED | | SCALE | RELEASE DATE | WEIGHT | SHEET |

| REVISIONS | | | | |
|-----------|-----|---------------------|------|----------|
| ZONE | REV | FINISHES: | DATE | APPROVED |
| | | 605,609,619,620,625 | | |

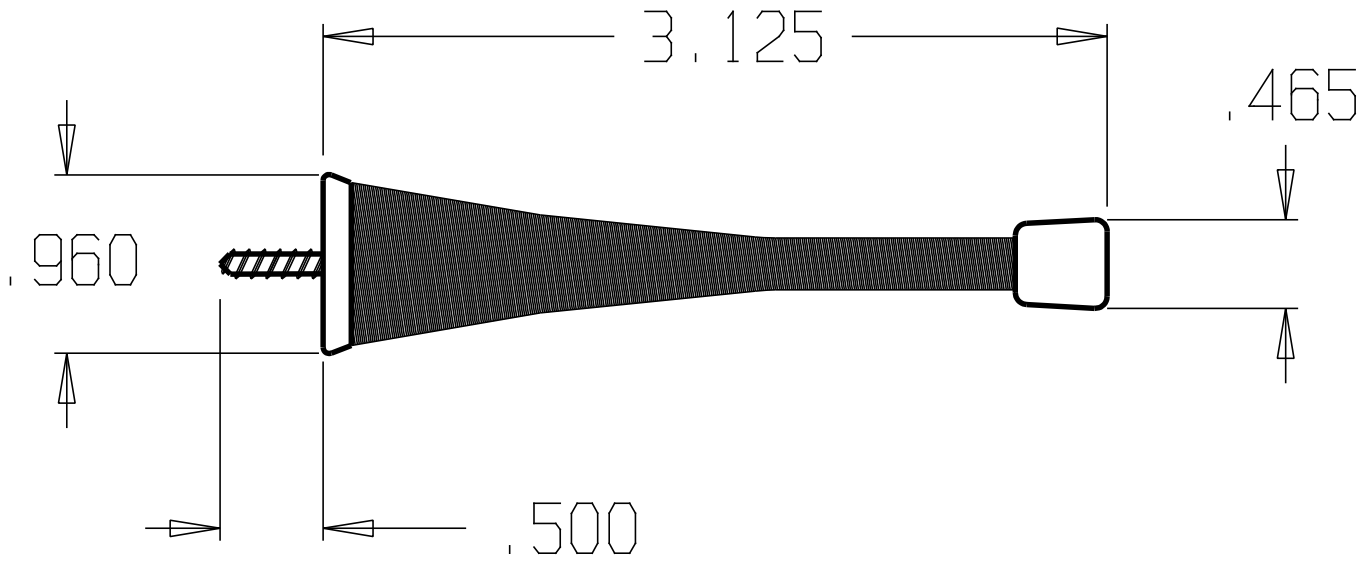

DON-JO MFG. INC.

| | | | | |
|----------|-------|--------------|----------|-------|
| DESIGNER | SIZE | DATE: | PART NO. | REV |
| | A | 3/23/04 | #1509 | |
| APPROVED | SCALE | RELEASE DATE | WEIGHT | SHEET |
| | | | | |

| REVISIONS | | | | |
|-----------|-----|-------------------------|------|----------|
| ZONE | REV | FINISHES: | DATE | APPROVED |
| | | 605, 609, 619, 620, 625 | | |

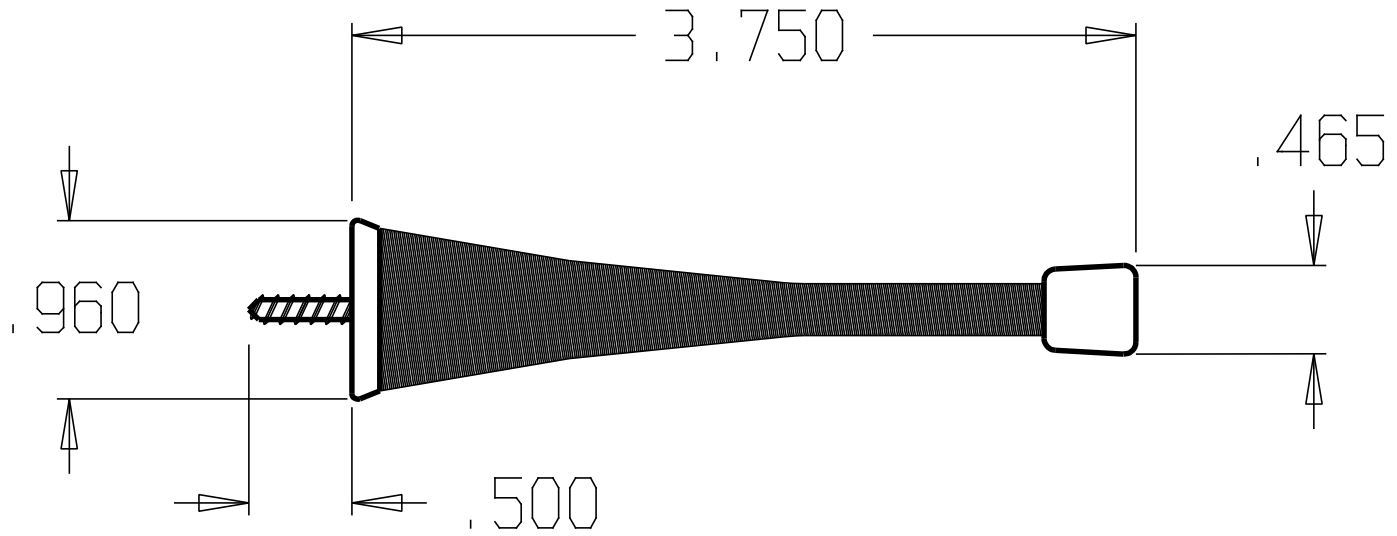

DON-JO MFG. INC.

| | | | | |
|----------|-----------|------------------|-------------------|-------|
| DESIGNER | SIZE A | DATE: 3/23/04 | PART NO. #1510 | REV |
| APPROVED | SCALE | RELEASE DATE | WEIGHT | SHEET |

| | | |
|--------|----|-----|
| DWG NO | SH | REV |
|--------|----|-----|

REVISIONS

| ZONE | REV | FINISHES: | GALUGE: |
|------|-----|-------------|---------|
| | | 613, BP, CP | |

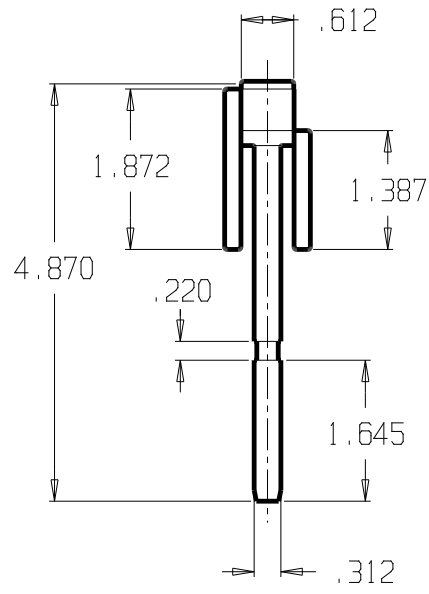

DON-JO MFG. INC.

| | | | | | | | | | |
|----------|------|-------|--------------|-------|---------|----------|-------|-----|--|
| DESIGNER | D.R. | SIZE | A | DATE: | 6/26/14 | PART NO. | #1512 | REV | |
| | | SCALE | RELEASE DATE | | WEIGHT | SHEET | | | |

| REVISIONS | | | | |
|-----------|-----|-----------|------|----------|
| ZONE | REV | FINISHES: | DATE | APPROVED |
| | | 626 | | |

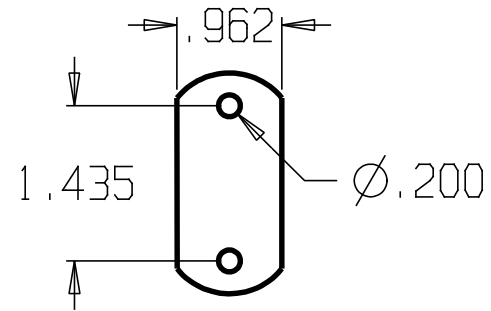
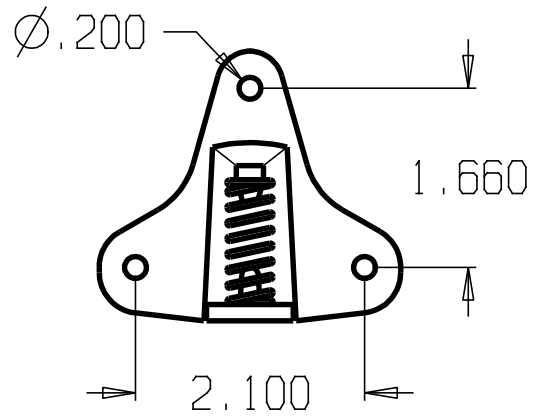
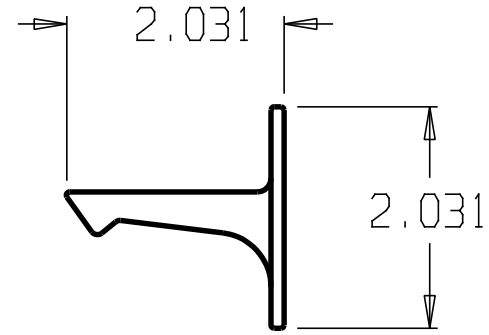
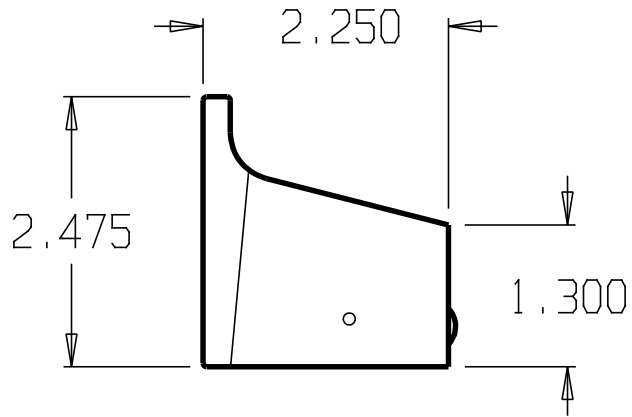

DON-JO MFG. INC.

| | | | | |
|----------|-----------|------------------|-------------------|-------|
| DESIGNER | SIZE A | DATE: 3/24/04 | PART NO. #1514 | REV |
| APPROVED | SCALE | RELEASE DATE | WEIGHT | SHEET |

| REVISIONS | | | | |
|-----------|-----|-----------|------|----------|
| ZONE | REV | FINISHES: | DATE | APPROVED |
| | | 626 | | |

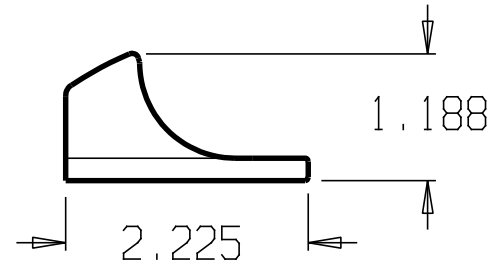
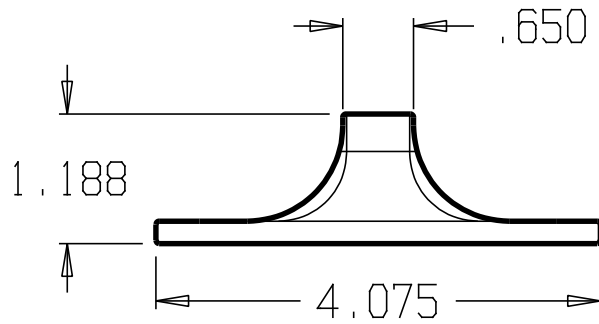
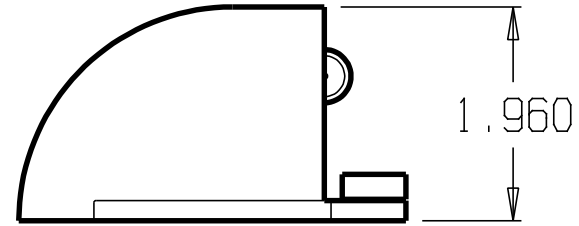
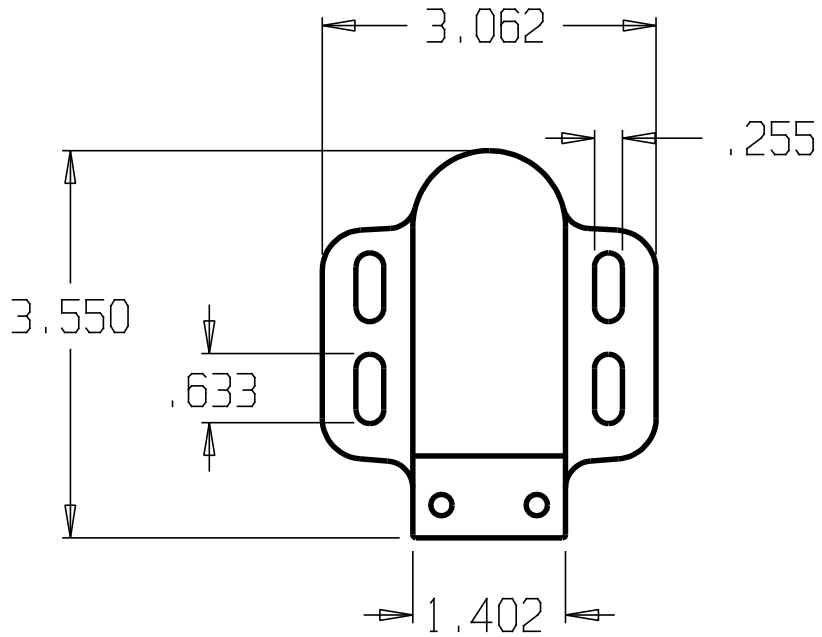

DON-JO MFG. INC.

| | | | | |
|----------|-----------|------------------|-------------------|-------|
| DESIGNER | SIZE A | DATE: 3/24/04 | PART NO. #1520 | REV |
| APPROVED | SCALE | RELEASE DATE | WEIGHT | SHEET |

| REVISIONS | | | | |
|-----------|-----|------------|------|----------|
| ZONE | REV | FINISHES : | DATE | APPROVED |
| | | 626 | | |

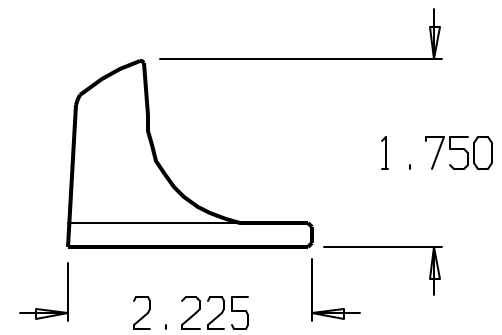
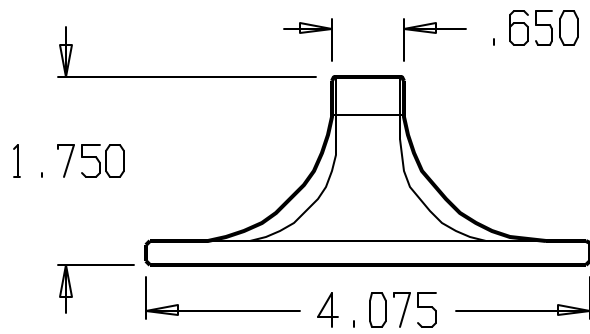
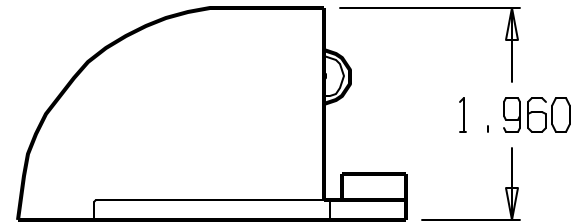
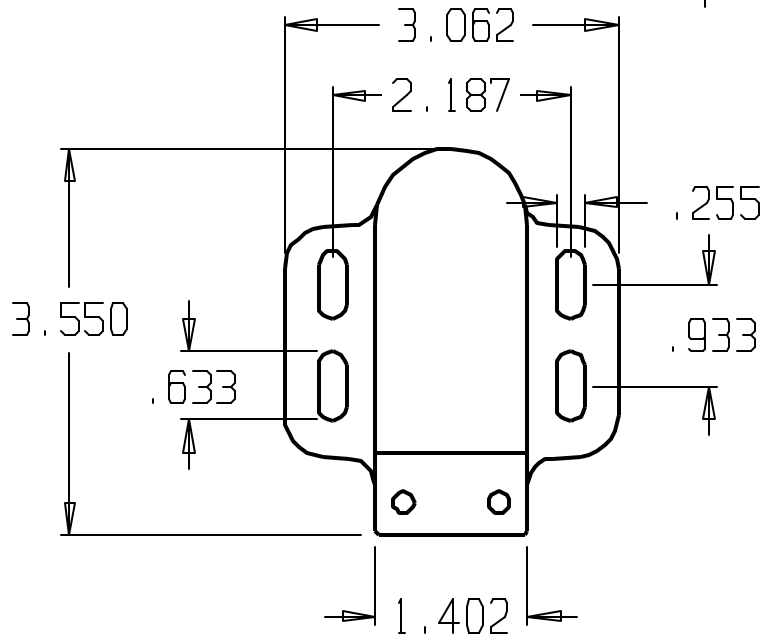

DON-JO MFG. INC.

DESIGNER
APPROVED

| | | | |
|-----------|-----------------|-------------------|-------|
| SIZE A | DATE 3/24/04 | PART NO. #1521 | REV |
| SCALE | RELEASE DATE | WEIGHT | SHEET |

| REVISIONS | | | | |
|-----------|-----|-----------|------|----------|
| ZONE | REV | FINISHES: | DATE | APPROVED |
| | | 626 | | |

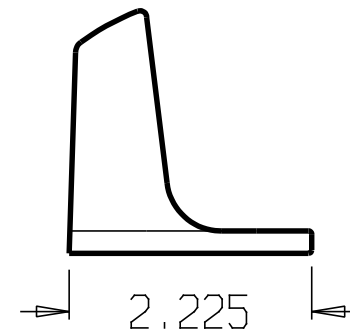
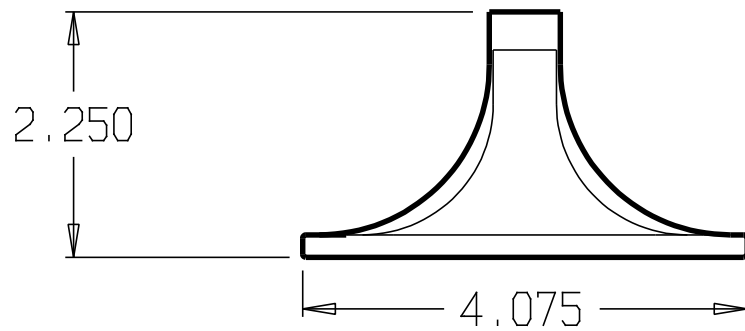
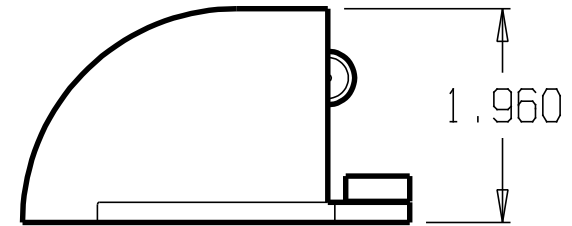
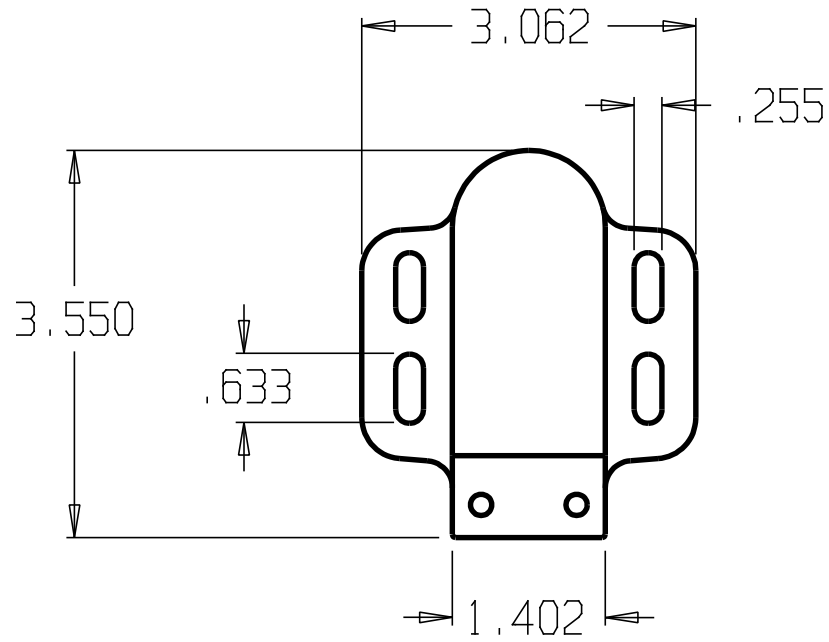

DON-JO MFG. INC.

| | | | | |
|----------|-------|--------------|----------|-------|
| DESIGNER | SIZE | DATE: | PART NO. | REV |
| | A | 3/24/04 | #1522 | |
| APPROVED | SCALE | RELEASE DATE | WEIGHT | SHEET |
| | | | | |

| REVISIONS | | | | |
|-----------|-----|------------|------|----------|
| ZONE | REV | FINISHES : | DATE | APPROVED |
| | | 626 | | |

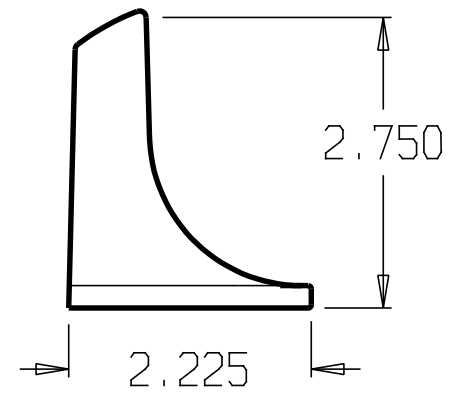
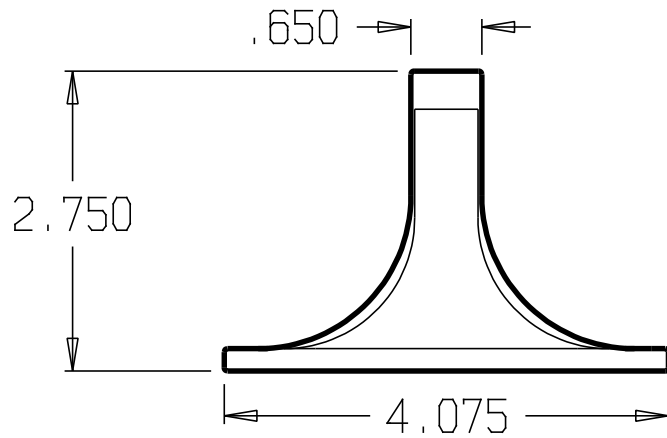
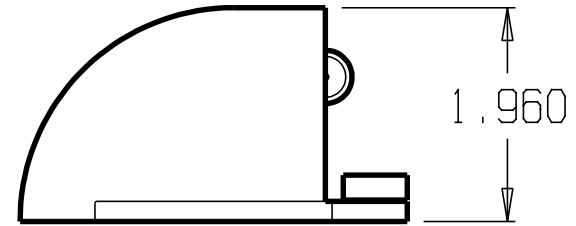
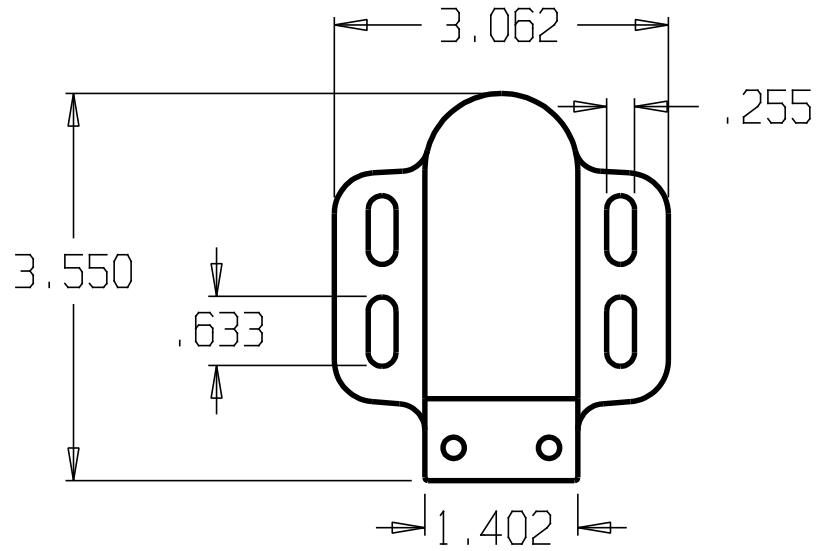

DON-JO MFG. INC.

| | | | | |
|----------|-------|--------------|----------|-------|
| DESIGNER | SIZE | DATE: | PART NO. | REV |
| | A | 3/24/04 | #1523 | |
| APPROVED | SCALE | RELEASE DATE | WEIGHT | SHEET |
| | | | | |

| REVISIONS | | | | |
|-----------|-----|-------------|------|----------|
| ZONE | REV | FINISHES: | DATE | APPROVED |
| | | GRAY RUBBER | | |

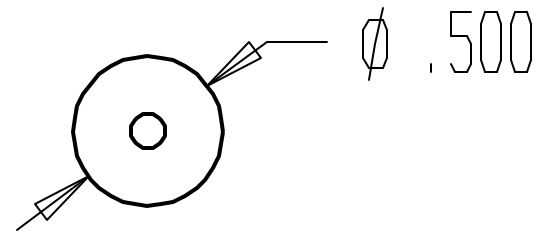
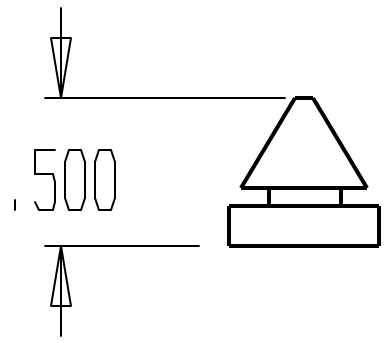

DON-JO MFG. INC.

| | | | | | | |
|----------|-------|---------|--------------|----------|--------|-----|
| DESIGNER | SCALE | DATE | RELEASE DATE | PART NO. | WEIGHT | REV |
| | A | 3/29/04 | | #1608 | | |
| APPROVED | | | | SHEET | | |

| REVISIONS | | | | |
|-----------|-----|-------------|------|----------|
| ZONE | REV | FINISHES: | DATE | APPROVED |
| | | GRAY RUBBER | | |

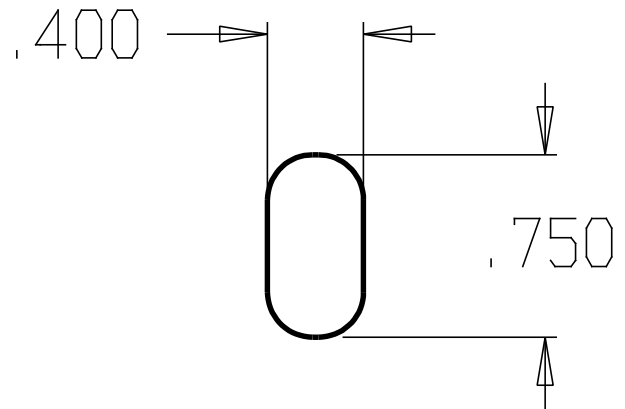
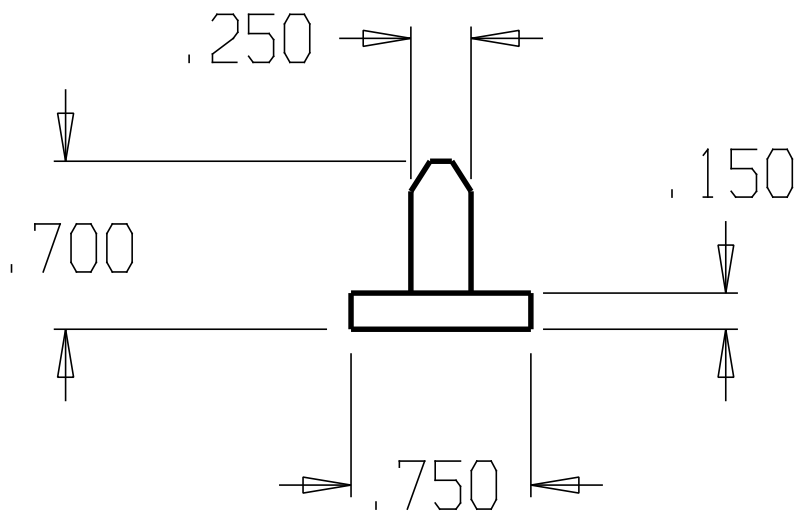

DON-JO MFG. INC.

| | | | | |
|----------|-------|--------------|----------|-------|
| DESIGNER | SIZE | DATE: | PART NO. | REV |
| | A | 3/29/04 | #1609 | |
| APPROVED | SCALE | RELEASE DATE | WEIGHT | SHEET |
| | | | | |

| REVISIONS | | | | |
|-----------|-----|---------------------|------|----------|
| ZONE | REV | FINISHES: | DATE | APPROVED |
| | | CLEAR & GRAY RUBBER | | |

135

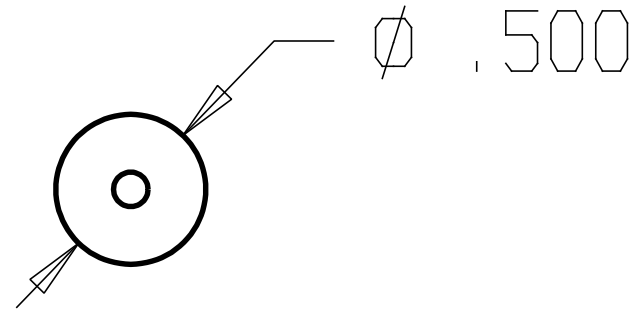
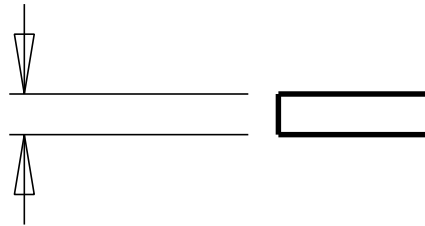

DON-JO MFG. INC.

| | | | | |
|----------|-----------|------------------|-------------------|-------|
| DESIGNER | SIZE A | DATE: 3/29/04 | PART NO. #1610 | REV |
| APPROVED | SCALE | RELEASE DATE | WEIGHT | SHEET |

| REVISIONS | | | | |
|-----------|-----|-----------|------|----------|
| ZONE | REV | FINISHES: | DATE | APPROVED |
| | | BP & SL | | |

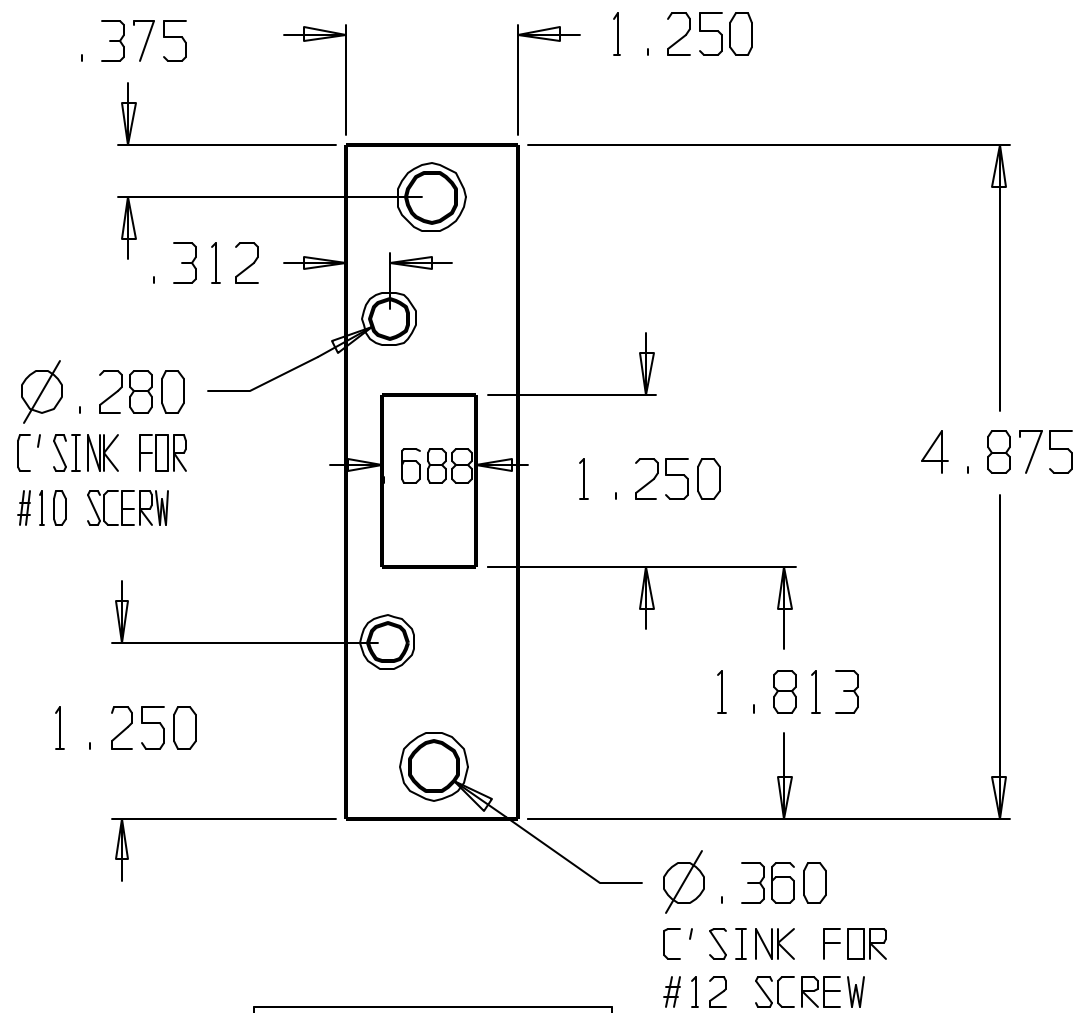

DON-JO MFG. INC.

DESIGNER
APPROVED

SIZE: A
DATE: 1/1/94
SCALE

PART NO.: 2 SDS
RELEASE DATE
WEIGHT

REV

| REVISIONS | | | | |
|-----------|-----|-----------|------|----------|
| ZONE | REV | FINISHES: | DATE | APPROVED |
| | | BP & SL | | |

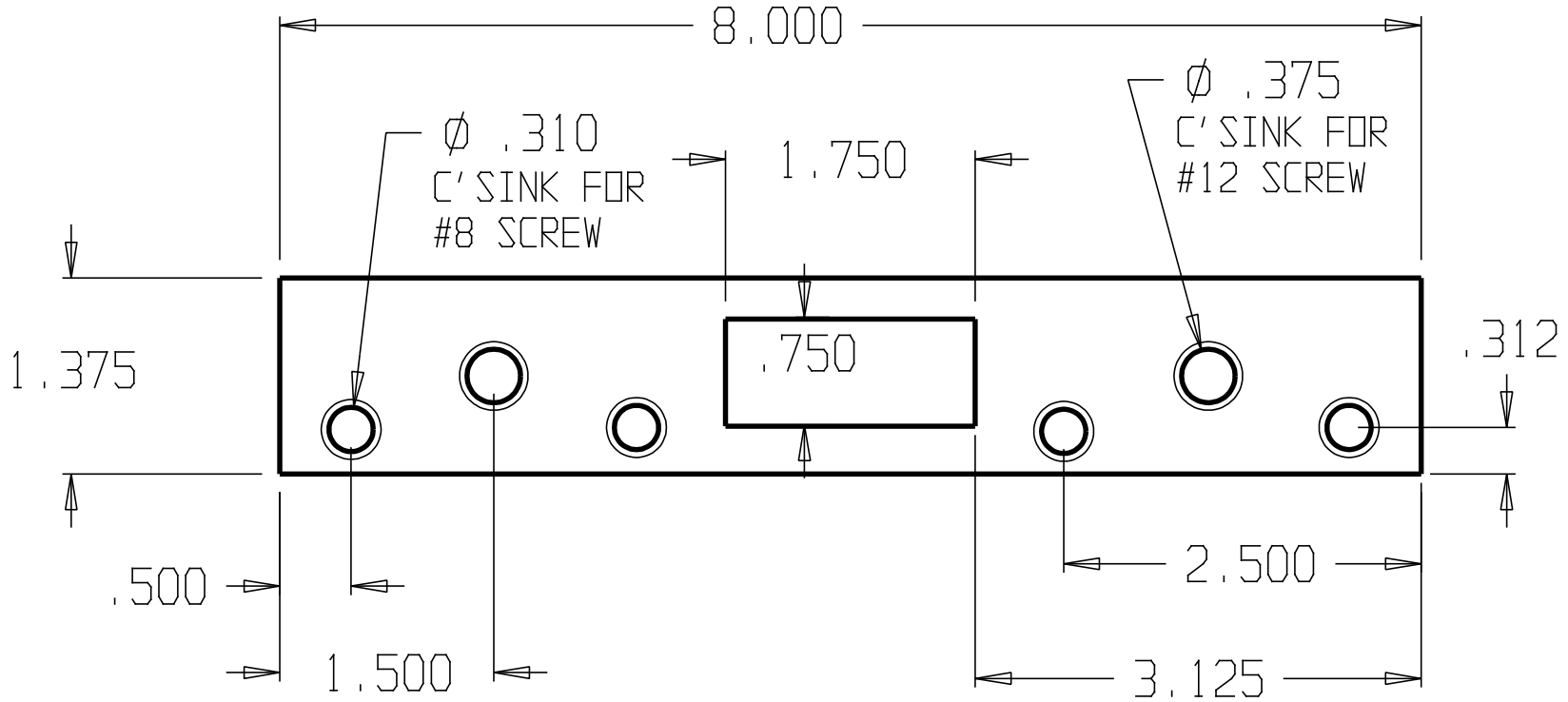

| | | | | |
|-------------------------|-----------|-----------------|---------------------|-------|
| DON-JO MFG. INC. | | | | |
| DESIGNER | SIZE A | DATE: 4/1/04 | PART NO. 2 SDS 8 | REV |
| APPROVED | SCALE | RELEASE DATE | WEIGHT | SHEET |

| REVISIONS | | | |
|-----------|-----|-----------|----------|
| ZONE | REV | FINISHES: | DATE |
| | | BP & SL | |
| | | | APPROVED |

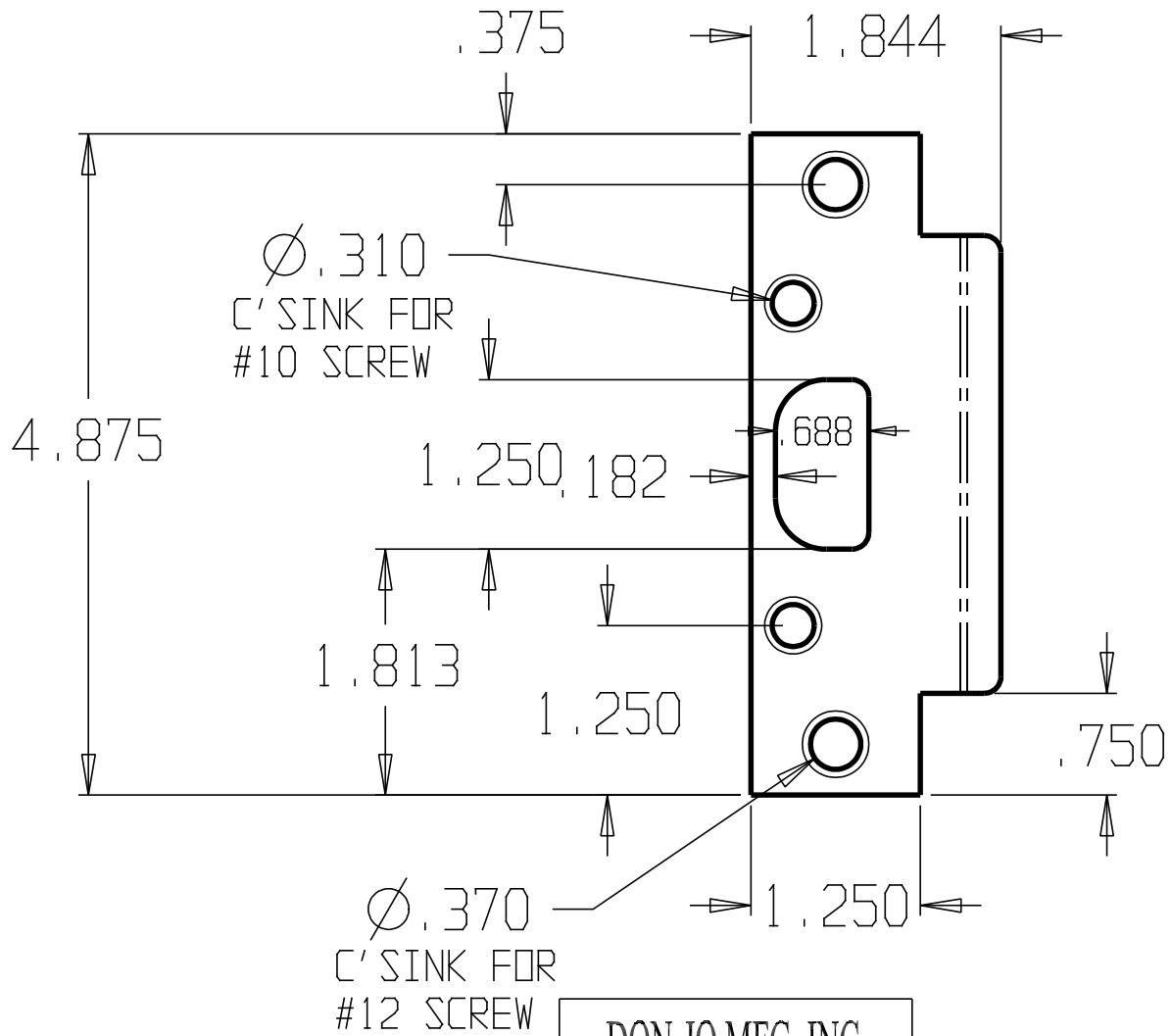

DON-JO MFG. INC.

DESIGNER
APPROVED

| | | | |
|-----------|-----------------|------------------|-------|
| SIZE A | DATE: 1/1/94 | PART NO. 2-SS | REV |
| SCALE | RELEASE DATE | WEIGHT | SHEET |

| REVISIONS | | | |
|-----------|-----|-----------|------------|
| ZONE | REV | FINISHES: | GALUGE: |
| | | BP & CP | 18ga. .045 |

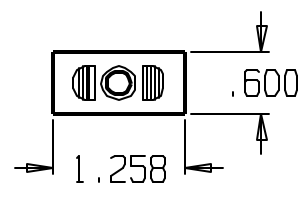
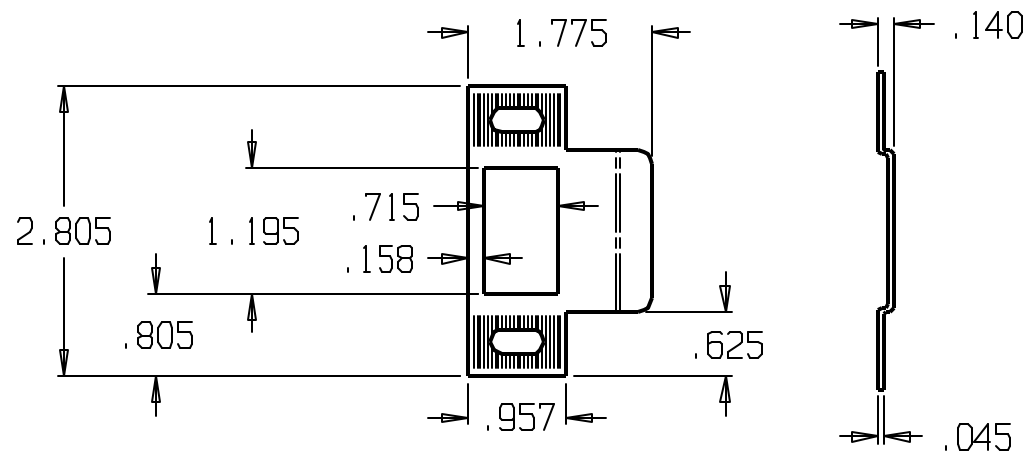

DON-JO MFG. INC.

DESIGNER: D.R.

| | | | |
|---------|---------------|----------------|--------|
| SIZE: A | DATE: 4/29/09 | PART NO.: 9450 | REV: |
| SCALE: | RELEASE DATE: | WEIGHT: | SHEET: |

| REVISIONS | | | |
|-----------|-----|-----------|------------|
| ZONE | REV | FINISHES: | GUAGE: |
| | | BP & SL | 13ga. .095 |

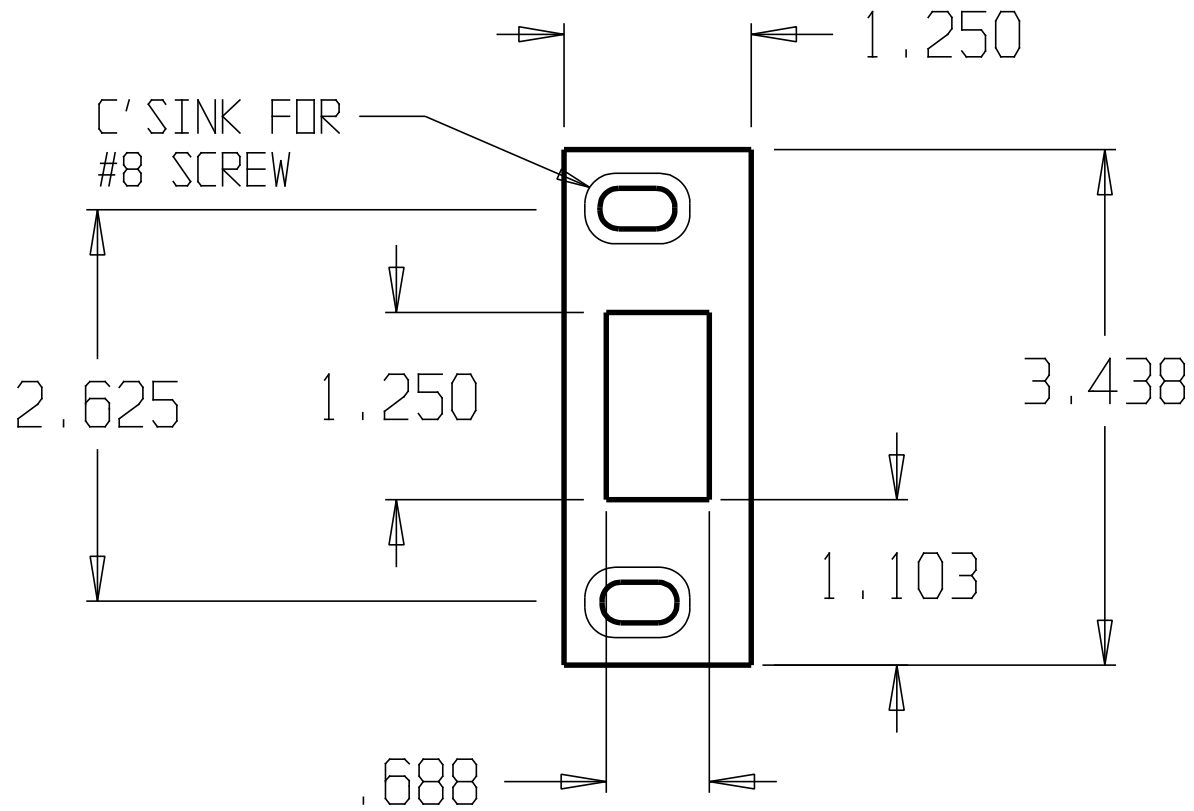

DON-JO MFG. INC.

| | | | | |
|----------|-------|--------------|----------|-------|
| DESIGNER | SIZE | DATE: | PART NO. | REV |
| | A | 4/20/04 | A-2-SDS | |
| APPROVED | SCALE | RELEASE DATE | WEIGHT | SHEET |
| | | | | |

| REVISIONS | | | | |
|-----------|-----|-----------|------|----------|
| ZONE | REV | FINISHES: | DATE | APPROVED |
| | | BP & SL | | |

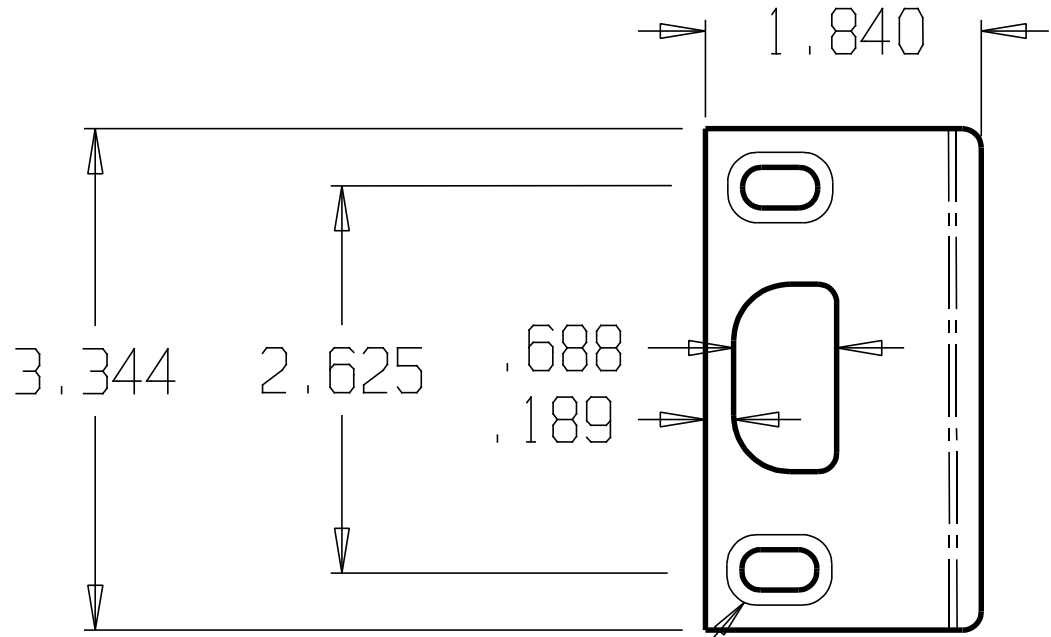

C' SINK FOR
#8 SCREW

| | | | | |
|------------------|-------|--------------|----------|-------|
| DON-JO MFG. INC. | | | | |
| DESIGNER | SIZE | DATE: | PART NO. | REV |
| | A | 4/30/04 | A-2-SS | |
| APPROVED | SCALE | RELEASE DATE | WEIGHT | SHEET |
| | | | | |

| REVISIONS | | |
|-----------|-----|----------------|
| ZONE | REV | FINISHES: |
| | | BP, SL & WHITE |
| | | GAUGE: |
| | | 13ga. .095 |

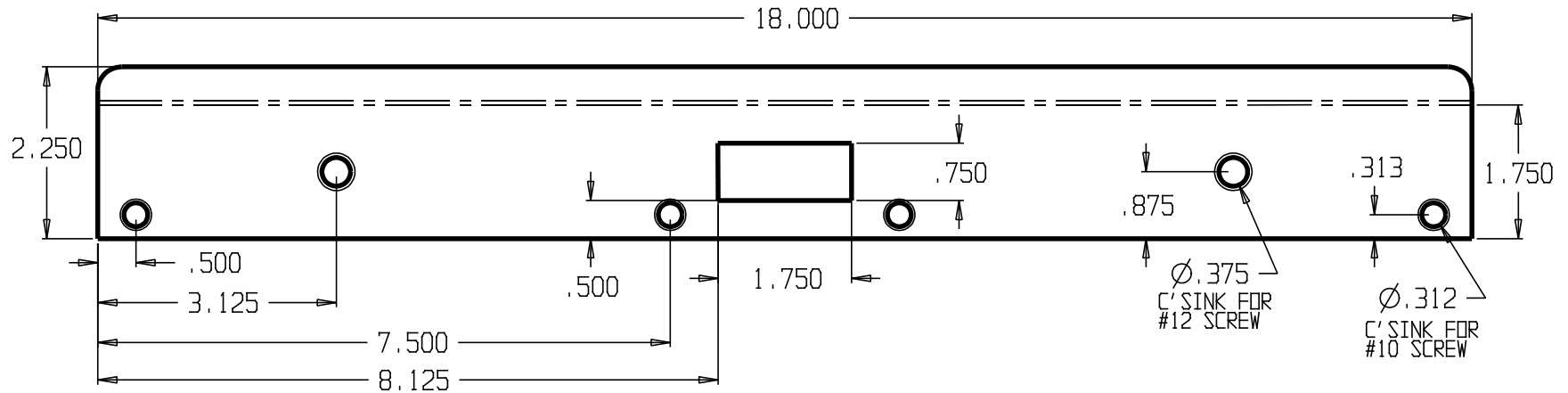

DON-JO MFG. INC.

| | | | | |
|----------|-------|--------------|-----------|-------|
| DESIGNER | SIZE | DATE: | PART NO. | REV |
| | A | 5/3/04 | AST-21341 | |
| APPROVED | SCALE | RELEASE DATE | WEIGHT | SHEET |
| | | | | |

| REVISIONS | | | |
|-----------|-----|-----------|------------|
| ZONE | REV | FINISHES: | GAUGE: |
| | | BP & SL | 13ga. .095 |

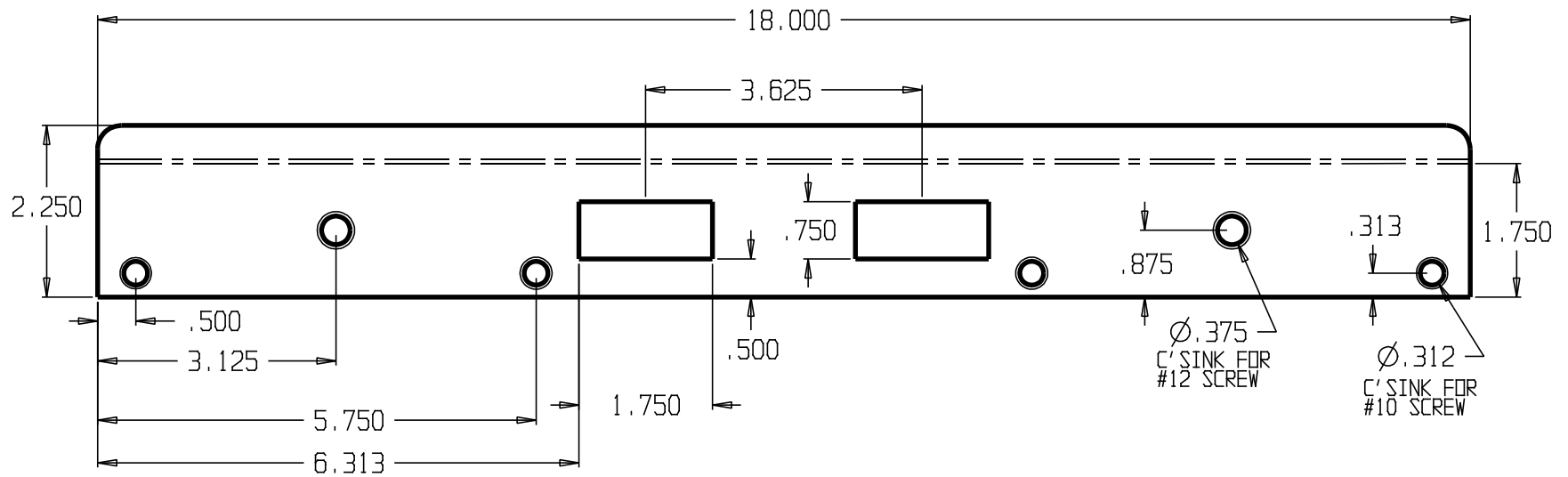

DON-JO MFG. INC.

| | |
|----------|--|
| DESIGNER | |
| APPROVED | |

| | | | |
|-------|--------------|-----------|-------|
| SIZE | DATE: | PART NO. | REV |
| A | 5/3/04 | AST-21342 | |
| SCALE | RELEASE DATE | WEIGHT | SHEET |

| REVISIONS | | |
|-----------|-----|----------------|
| ZONE | REV | FINISHES: |
| | | BP, SL & WHITE |
| | | GUAGE: |
| | | 13ga. .095 |

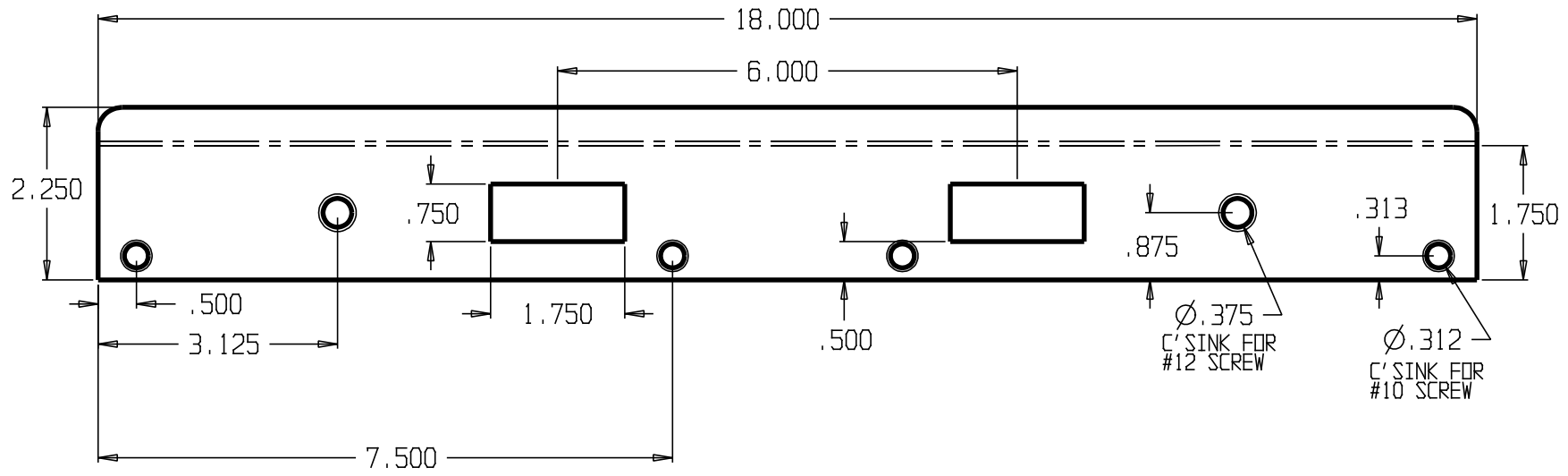

DON-JO MFG. INC.

| | |
|----------|--|
| DESIGNER | |
| APPROVED | |

| | | | |
|-------|--------------|-----------|-------|
| SIZE | DATE: | PART NO. | REV |
| A | 5/3/04 | AST-21346 | |
| SCALE | RELEASE DATE | WEIGHT | SHEET |

| REVISIONS | | |
|-----------|-----|----------------|
| ZONE | REV | FINISHES: |
| | | BP, SL & WHITE |
| | | GAUGE: |
| | | 13ga. .095 |

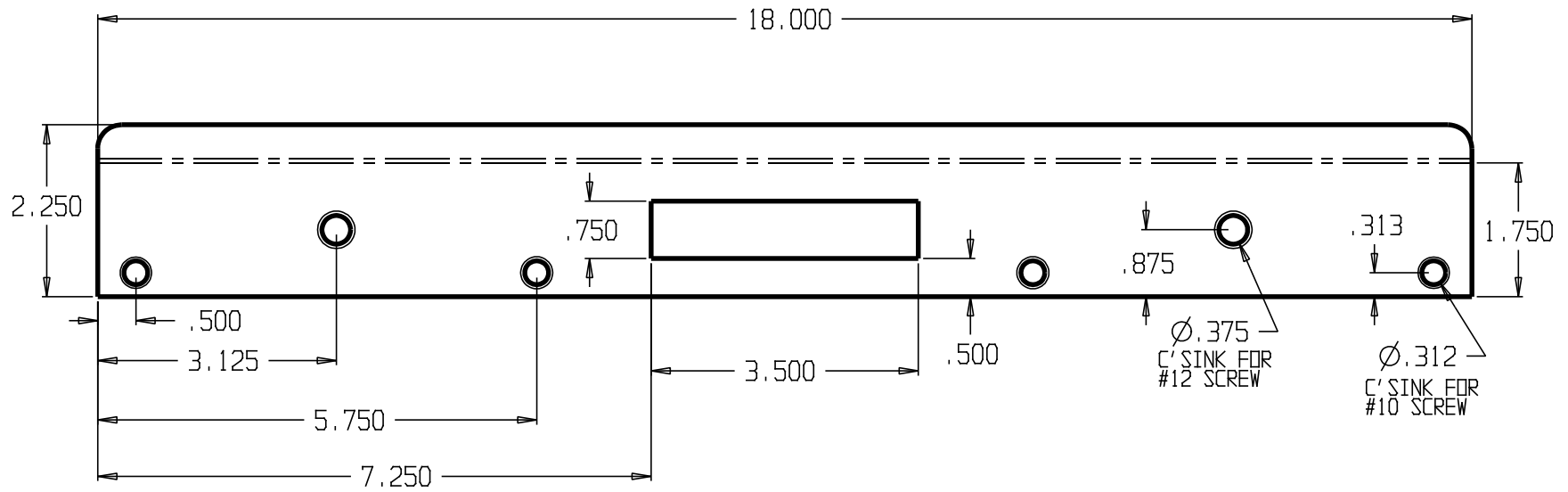

DON-JO MFG. INC.

| | | | | |
|----------|---------|--------------|--------------------|-------|
| DESIGNER | SIZE: A | DATE: 5/3/04 | PART NO. AST-2134M | REV |
| APPROVED | SCALE | RELEASE DATE | WEIGHT | SHEET |

| REVISIONS | | | |
|-----------|-----|-----------|-----------|
| ZONE | REV | FINISHES: | GAUGE: |
| | | BP | 13ga .095 |

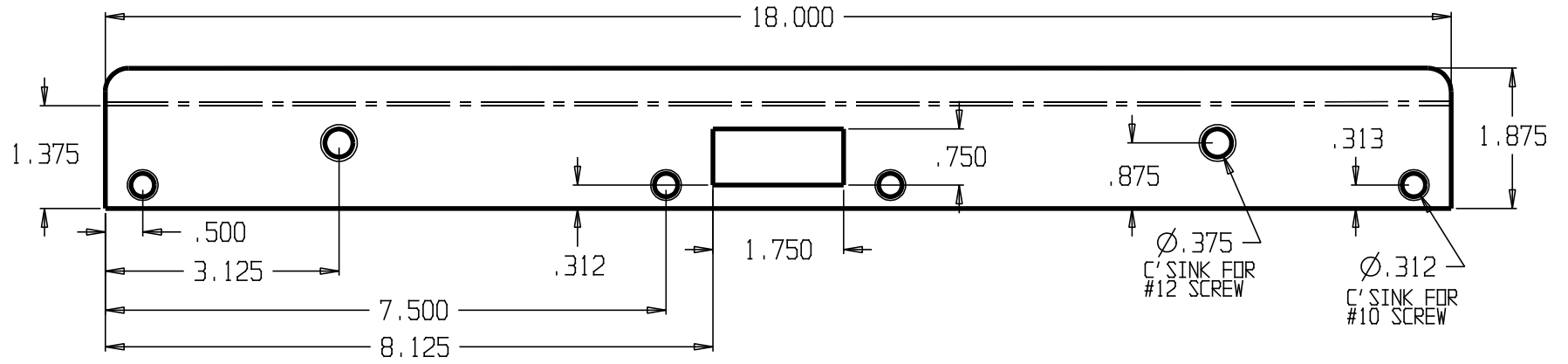

| | | | |
|------------------|---------|--------------|--------------------|
| DON-JO MFG. INC. | | | |
| DESIGNER | SIZE: A | DATE: 5/3/04 | PART NO. AST-21381 |
| APPROVED | SCALE | RELEASE DATE | WEIGHT |
| | | | SHEET |

| REVISIONS | | | |
|-----------|-----|-----------|------------|
| ZONE | REV | FINISHES: | GALUGE: |
| | | BP | 13ga. .095 |

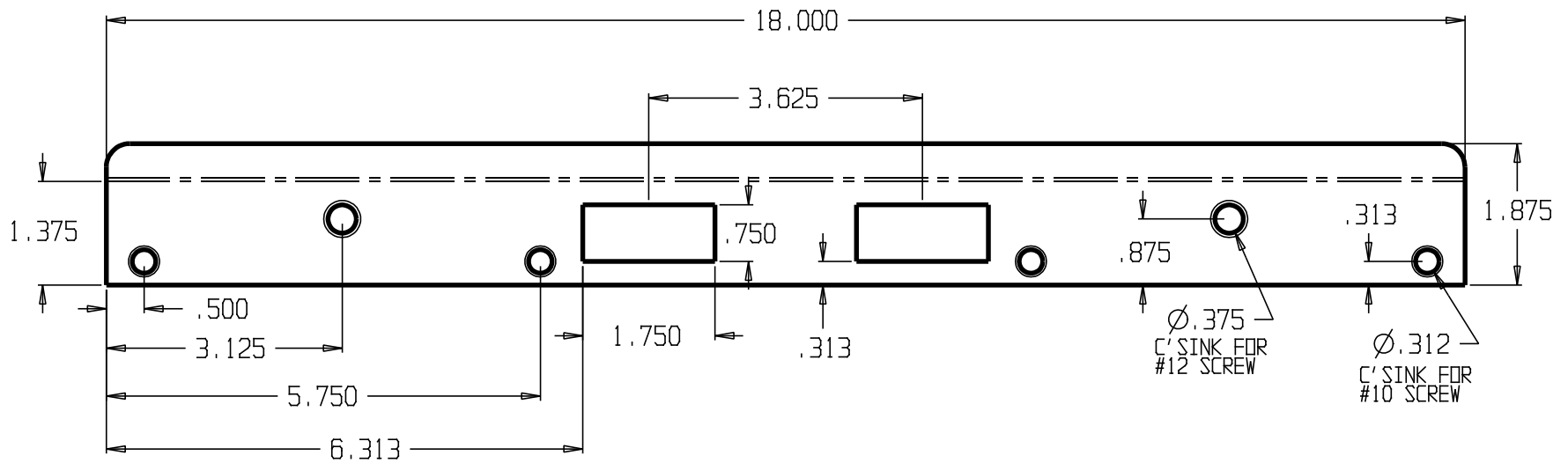

DON-JO MFG. INC.

DESIGNER
APPROVED

SIZE: A
DATE: 5/3/04
SCALE

PART NO.: AST-21382
WEIGHT
SHEET
REV

| REVISIONS | | |
|-----------|-----|------------|
| ZONE | REV | FINISHES: |
| | | BP |
| | | GALUGE: |
| | | 13ga. .095 |

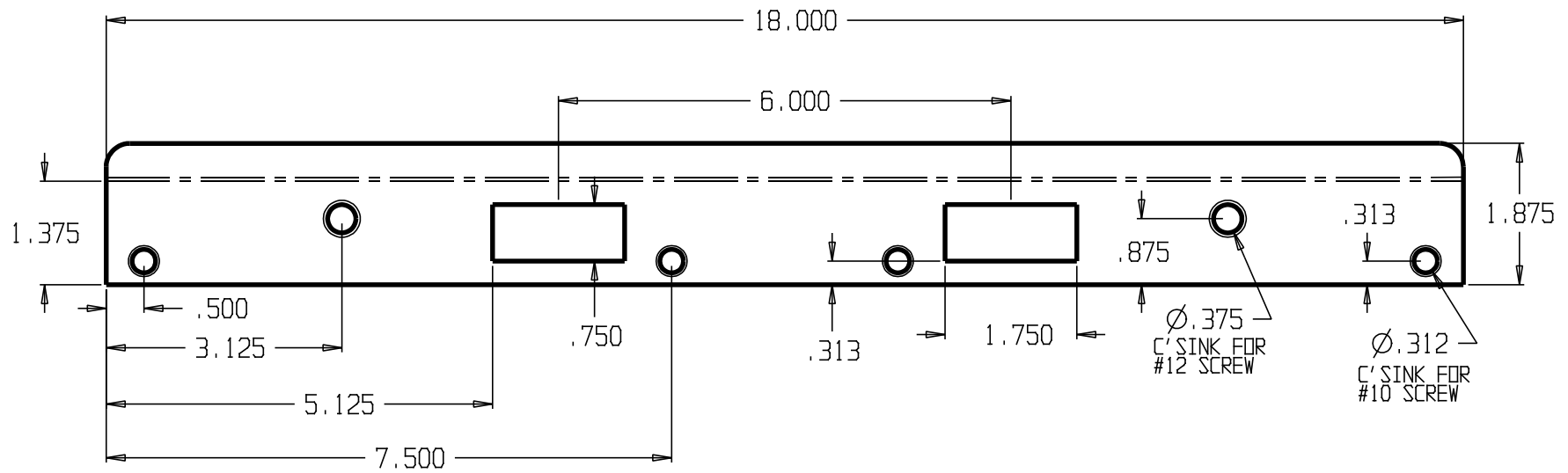

DON-JO MFG. INC.

DESIGNER
APPROVED

SIZE: A
DATE: 5/3/04

PART NO.: AST-21386
REV

SCALE
RELEASE DATE
WEIGHT
SHEET

| REVISIONS | | | |
|-----------|-----|-----------|------------|
| ZONE | REV | FINISHES: | GALUGE: |
| | | BP | 13ga. .095 |

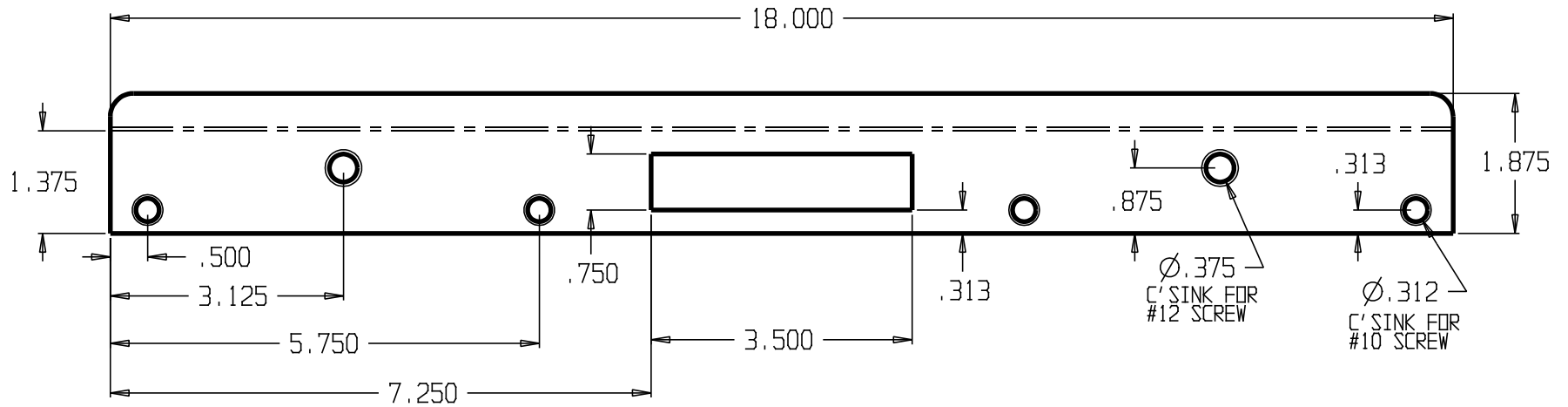

DON-JO MFG. INC.

| | |
|----------|--|
| DESIGNER | |
| APPROVED | |

| | | | |
|-------|--------------|-----------|-------|
| SIZE | DATE: | PART NO. | REV |
| A | 5/3/04 | AST-2138M | |
| SCALE | RELEASE DATE | WEIGHT | SHEET |
| | | | |

| REVISIONS | | | |
|-----------|-----|-----------|------------|
| ZONE | REV | FINISHES: | GALIGE: |
| | | BP & SL | 13ga. .095 |

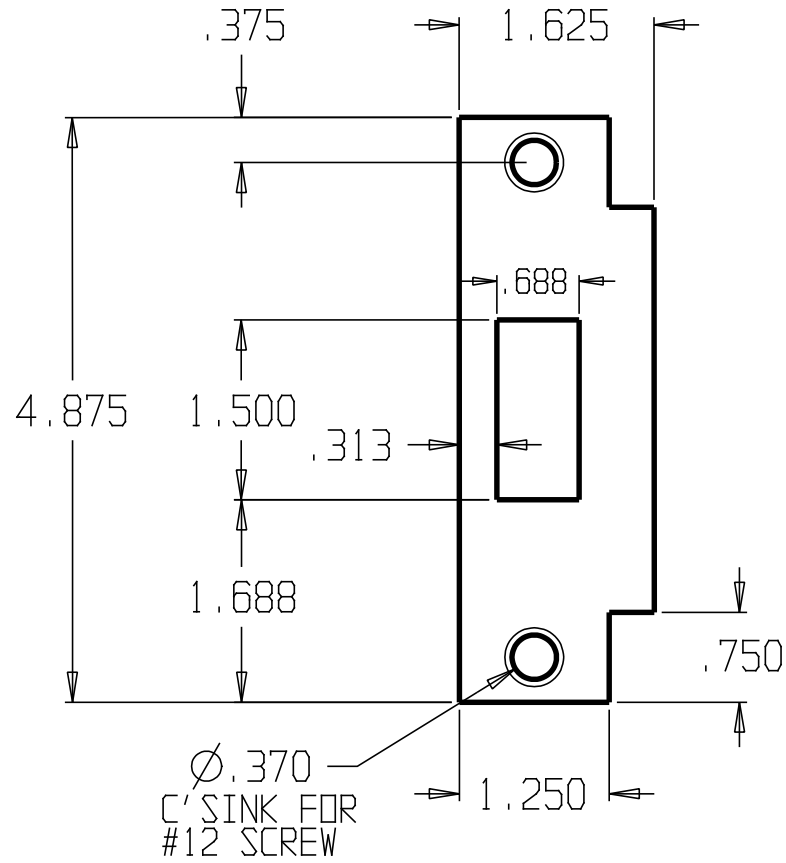

| | |
|------------------|--|
| DON-JO MFG. INC. | |
| DESIGNER | |
| APPROVED | |

| | | | |
|-------|--------------|----------|-------|
| SIZE | DATE: | PART NO. | REV |
| A | 5/4/04 | BFD-2 | |
| SCALE | RELEASE DATE | WEIGHT | SHEET |

| REVISIONS | | | |
|-----------|-----|-----------------|------------|
| ZONE | REV | FINISHES: | GUAGE: |
| | | 605,612,626,630 | 13ga. .095 |

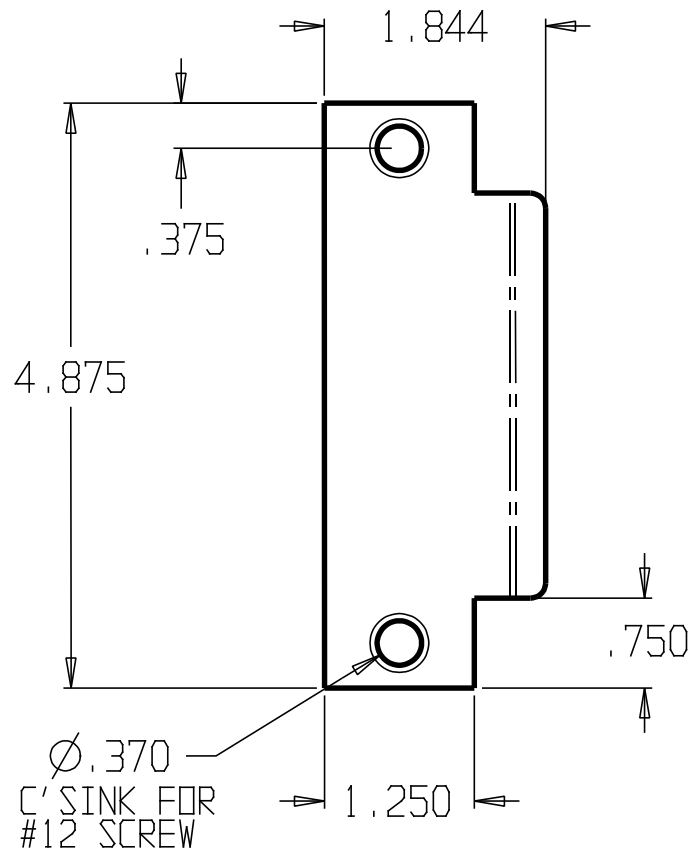

DON-JO MFG. INC.

| | | | | |
|----------|-------|--------------|----------|-------|
| DESIGNER | SIZE | DATE: | PART NO. | REV |
| | A | 5/4/04 | BS-161 | |
| APPROVED | SCALE | RELEASE DATE | WEIGHT | SHEET |

| REVISIONS | | | |
|-----------|-----|-----------|------------|
| ZONE | REV | FINISHES: | GUAGE: |
| | | BP & SL | 16ga. .060 |

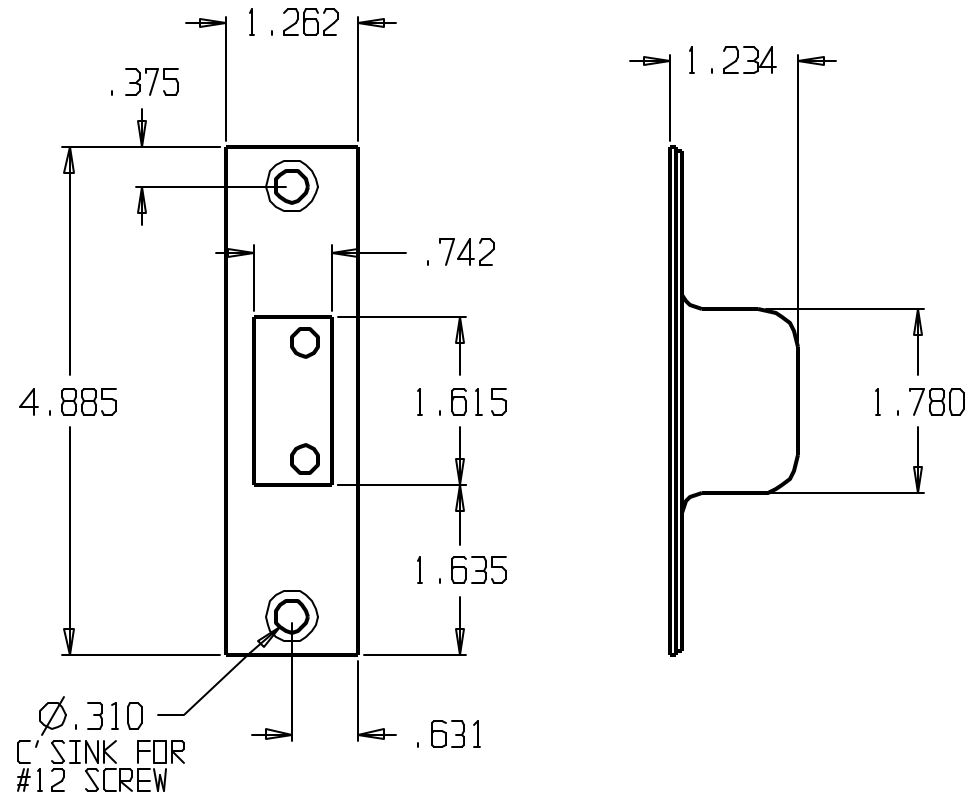

DON-JO MFG. INC.

| | | | | |
|------------------|-----------|----------------|----------------------|-------|
| DESIGNER D.R. | SIZE A | DATE 3/5/11 | PART NO. BX-2-SDS | REV |
| | SCALE | RELEASE DATE | WEIGHT | SHEET |

| | | |
|---------|----|-----|
| DWG NO. | SH | REV |
|---------|----|-----|

| REVISIONS | | FINISHES: | GUAGE: |
|-----------|-----|----------------|------------|
| ZONE | REV | 605, 609 & 630 | 18ga. .050 |

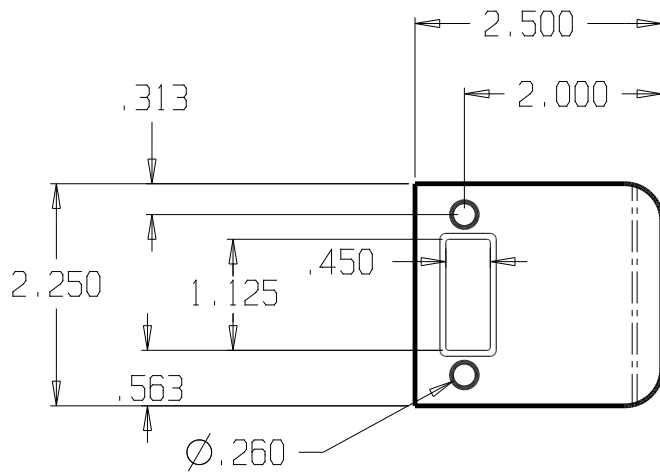

DON-JO MFG. INC.

| | | | | |
|----------|-------|--------------|----------|-------|
| DESIGNER | SIZE | DATE: | PART NO. | REV |
| | A | 8/11/11 | D9102 | |
| APPROVED | SCALE | RELEASE DATE | WEIGHT | SHEET |

| | | |
|--------|----|-----|
| DWG NO | SH | REV |
|--------|----|-----|

| REVISIONS | | FINISHES: | GUAGE: |
|-----------|-----|----------------|------------|
| ZONE | REV | 605, 609 & 630 | 18ga. .050 |

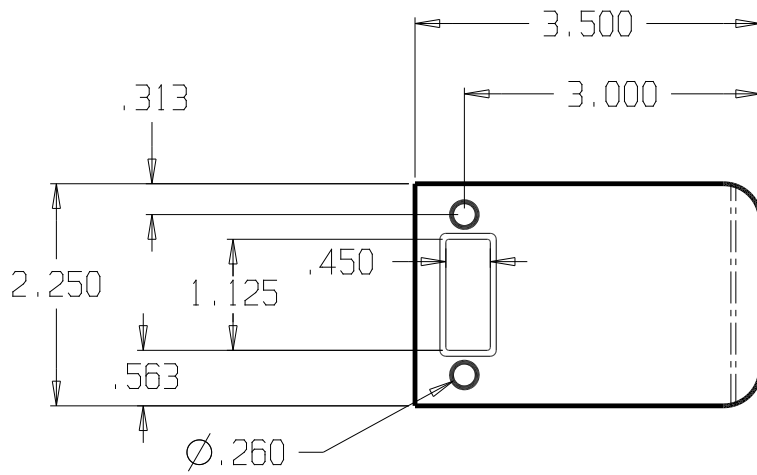

DON-JO MFG. INC.

| | | | | |
|----------|-------|--------------|----------|-------|
| DESIGNER | SIZE | DATE: | PART NO. | REV |
| | A | 8/11/11 | D9103 | |
| APPROVED | SCALE | RELEASE DATE | WEIGHT | SHEET |

| | | |
|---------|----|-----|
| DWG NO. | SH | REV |
|---------|----|-----|

| REVISIONS | | FINISHES: | GUAGE: |
|-----------|-----|----------------|------------|
| ZONE | REV | 605, 609 & 630 | 18ga. .050 |

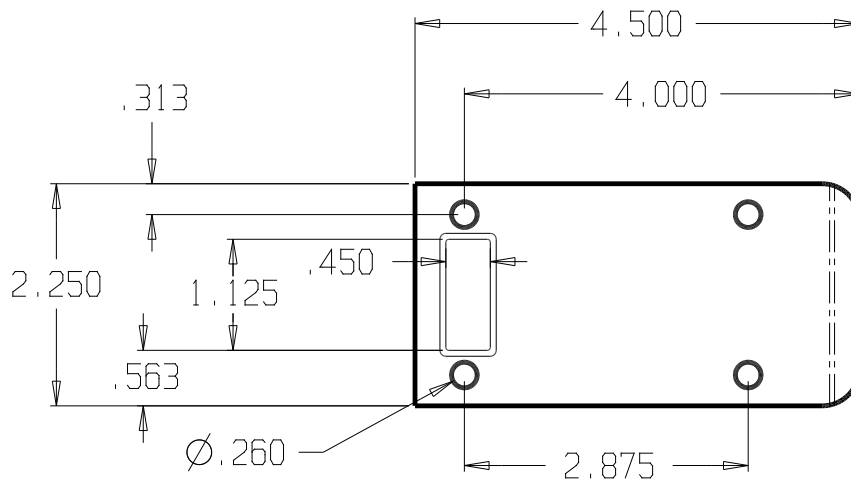

DON-JO MFG. INC.

| | | | | |
|----------|-------|--------------|----------|-------|
| DESIGNER | SIZE | DATE: | PART NO. | REV |
| | A | 8/11/11 | D9104 | |
| APPROVED | SCALE | RELEASE DATE | WEIGHT | SHEET |

| | | |
|---------|----|-----|
| DWG NO. | SH | REV |
|---------|----|-----|

| REVISIONS | | |
|-----------|-----|----------------|
| ZONE | REV | FINISHES: |
| | | 605, 609 & 630 |
| | | Gauge: |
| | | 18ga. .050 |

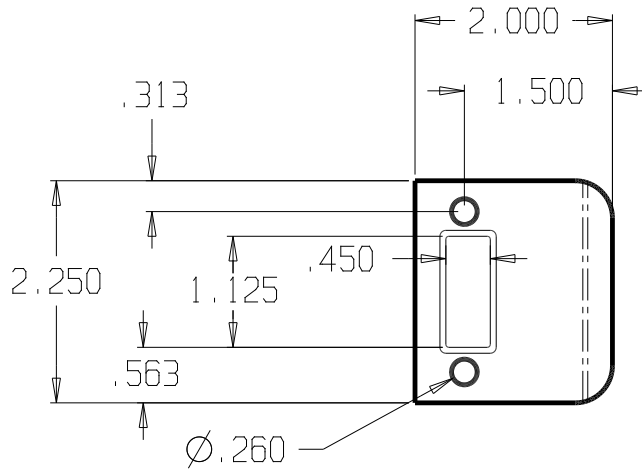

DON-JO MFG. INC.

| | | | | |
|----------|---------|---------------|-----------------|-------|
| DESIGNER | SIZE: A | DATE: 8/11/11 | PART NO.: D9115 | REV |
| APPROVED | SCALE | RELEASE DATE | WEIGHT | SHEET |

| | | |
|---------|----|-----|
| DWG NO. | SH | REV |
|---------|----|-----|

| REVISIONS | | FINISHES: | GUAGE: |
|-----------|-----|----------------|------------|
| ZONE | REV | 605, 609 & 630 | 18ga. .050 |

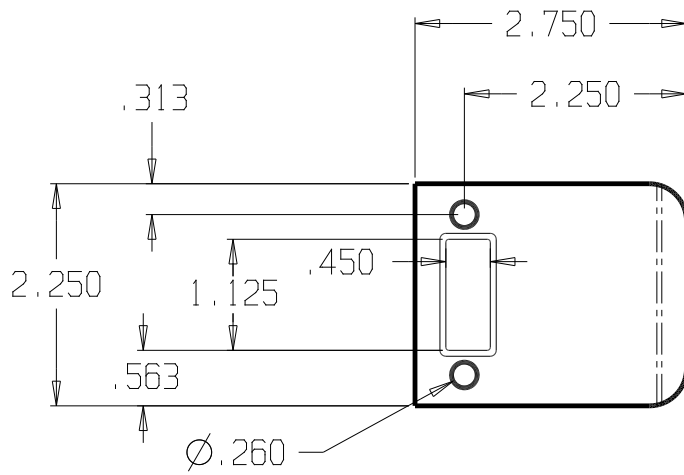

DON-JO MFG. INC.

| | | | | |
|----------|-------|--------------|----------|-------|
| DESIGNER | SIZE | DATE: | PART NO. | REV |
| | A | 8/11/11 | D9125 | |
| APPROVED | SCALE | RELEASE DATE | WEIGHT | SHEET |

| | | |
|---------|----|-----|
| DWG NO. | SH | REV |
|---------|----|-----|

| REVISIONS | | FINISHES: | GUAGE: |
|-----------|-----|----------------|------------|
| ZONE | REV | 605, 609 & 630 | 18ga. .050 |

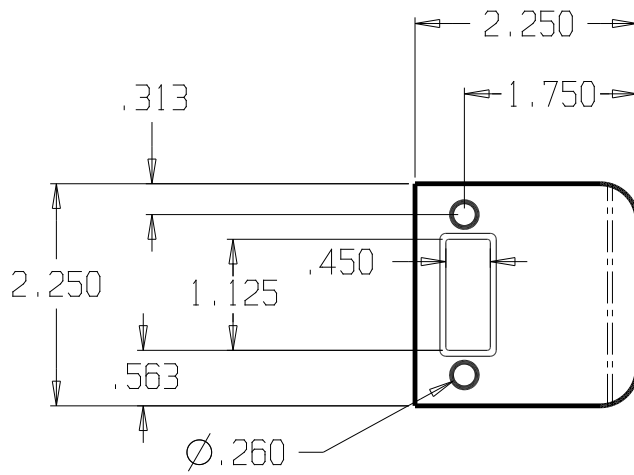

DON-JO MFG. INC.

| | | | | |
|----------|-------|--------------|----------|-------|
| DESIGNER | SIZE | DATE: | PART NO. | REV |
| | A | 8/11/11 | D9175 | |
| APPROVED | SCALE | RELEASE DATE | WEIGHT | SHEET |

| REVISIONS | | | |
|-----------|-----|-----------|------------|
| ZONE | REV | FINISHES: | GAUGE: |
| | | 605,626 | 13ga. .095 |

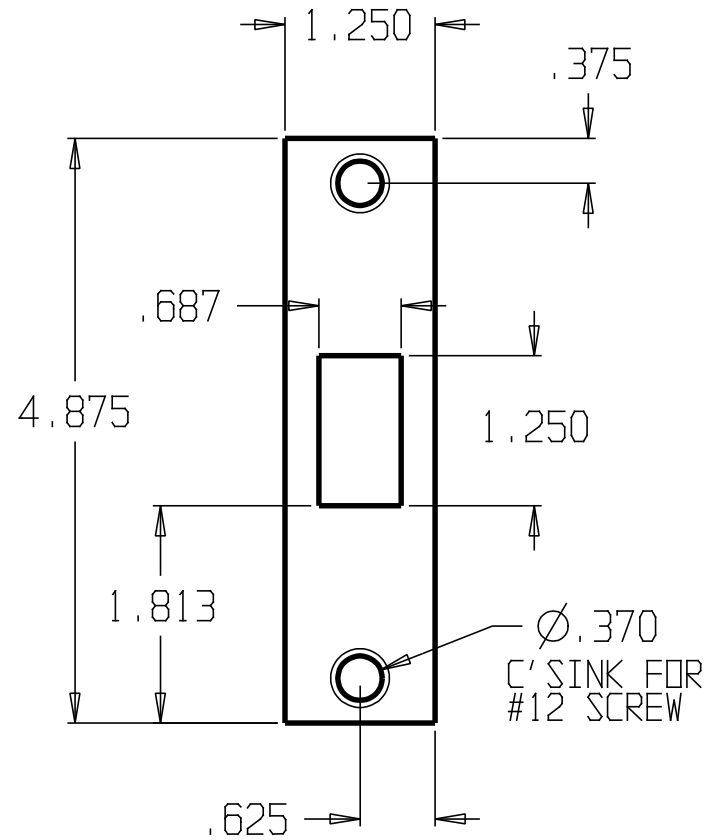

DON-JO MFG. INC.

| | | | | |
|----------|-------|--------------|----------|-------|
| DESIGNER | SIZE | DATE: | PART NO. | REV |
| | A | 5/7/04 | DBS-1478 | |
| APPROVED | SCALE | RELEASE DATE | WEIGHT | SHEET |
| | | | | |

| REVISIONS | | | |
|-----------|-----|-------------|------------|
| ZONE | REV | FINISHES: | GAUGE: |
| | | BP, DU & SL | 13ga. .095 |

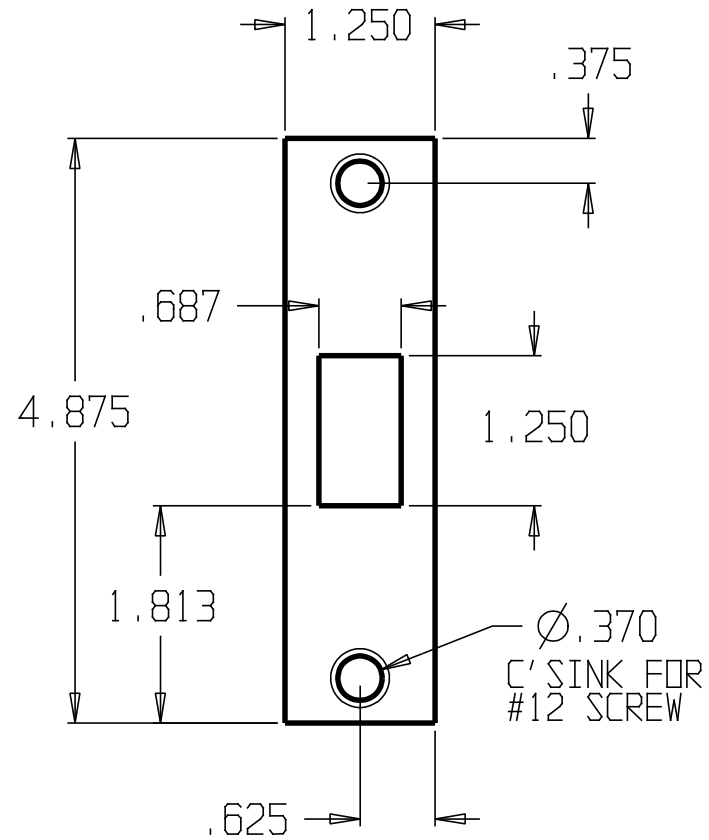

DON-JO MFG. INC.

| | | | | |
|----------|-------|--------------|----------|-------|
| DESIGNER | SIZE | DATE: | PART NO. | REV |
| | A | 5/7/04 | DBS-2478 | |
| APPROVED | SCALE | RELEASE DATE | WEIGHT | SHEET |
| | | | | |

| REVISIONS | | | |
|-----------|-----|------------|------------|
| ZONE | REV | FINISHES : | GALUGE : |
| | | 630 | 13ga. .090 |

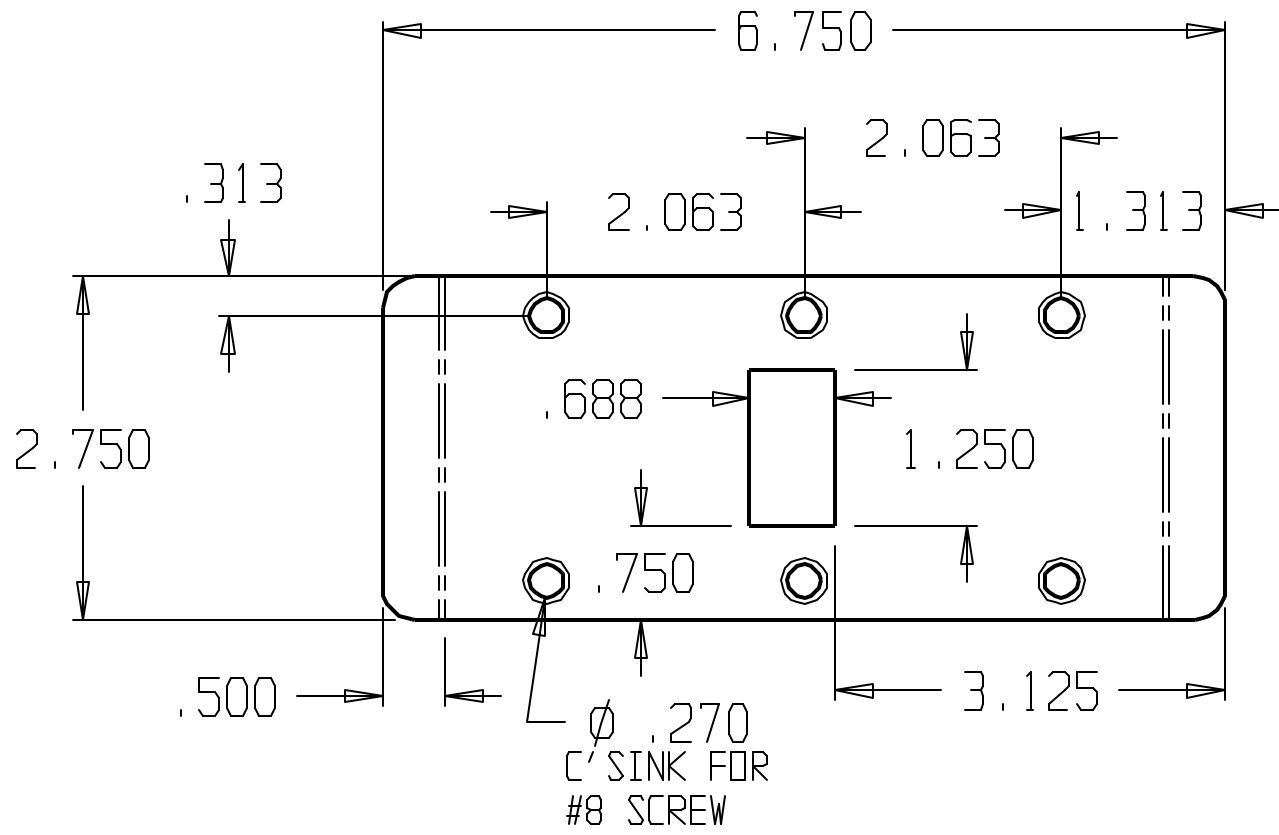

DON-JO MFG. INC.

| | | | | |
|----------|-------|--------------|----------|-------|
| DESIGNER | SIZE | DATE: | PART NO. | REV |
| | A | 3/16/11 | DL-11 | |
| APPROVED | SCALE | RELEASE DATE | WEIGHT | SHEET |

| REVISIONS | | | |
|-----------|-----|------------|-----------|
| ZONE | REV | FINISHES : | GALUGE : |
| | | 630 | 13ga .090 |

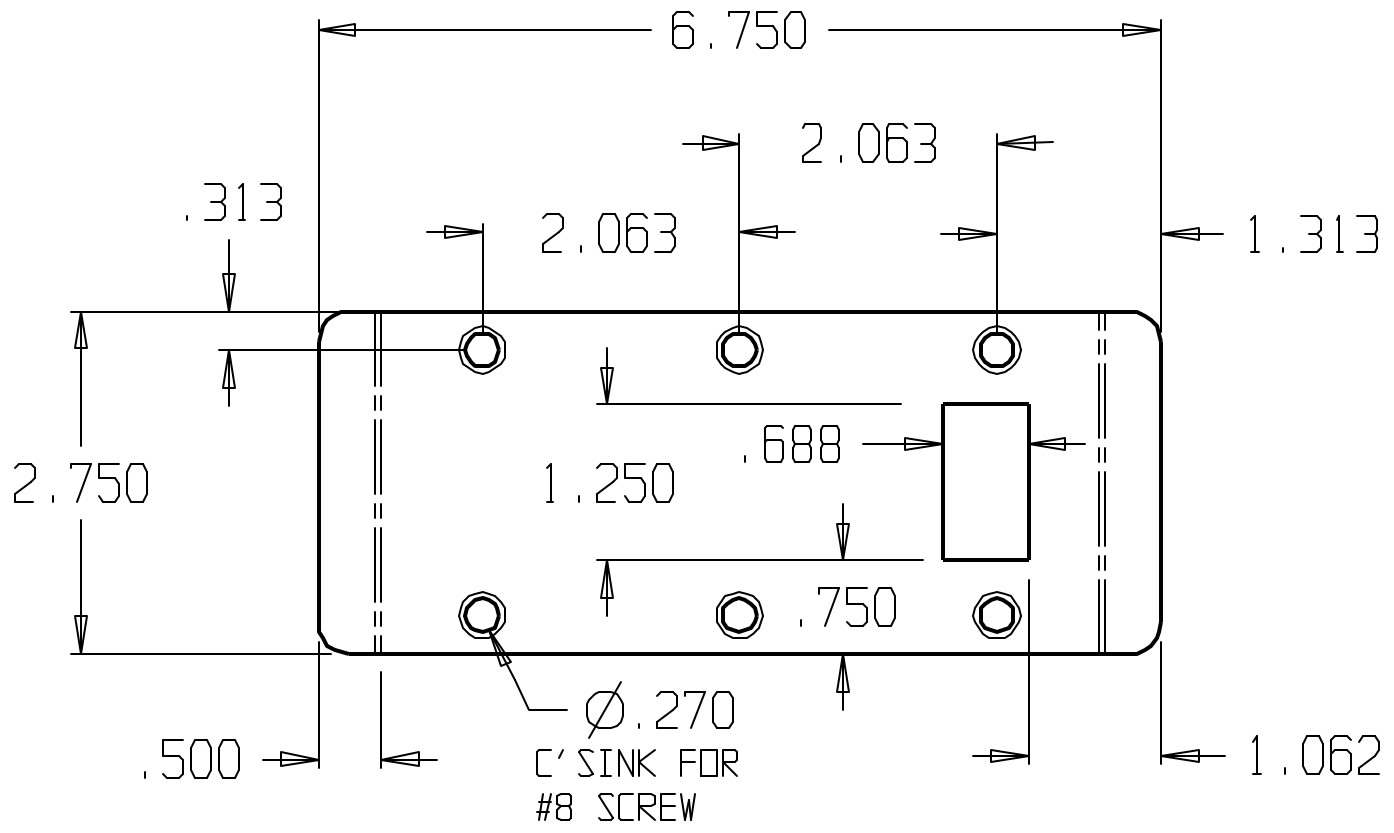

DON-JO MFG. INC.

| | |
|----------|--|
| DESIGNER | |
| APPROVED | |

| | | | |
|-------|--------------|----------|-------|
| SIZE | DATE: | PART NO. | REV |
| A | 3/16/11 | DL-12 | |
| SCALE | RELEASE DATE | WEIGHT | SHEET |

| REVISIONS | | | |
|-----------|-----|-----------|------------|
| ZONE | REV | FINISHES: | GAUGE: |
| | | 605 & 630 | 18ga. .050 |

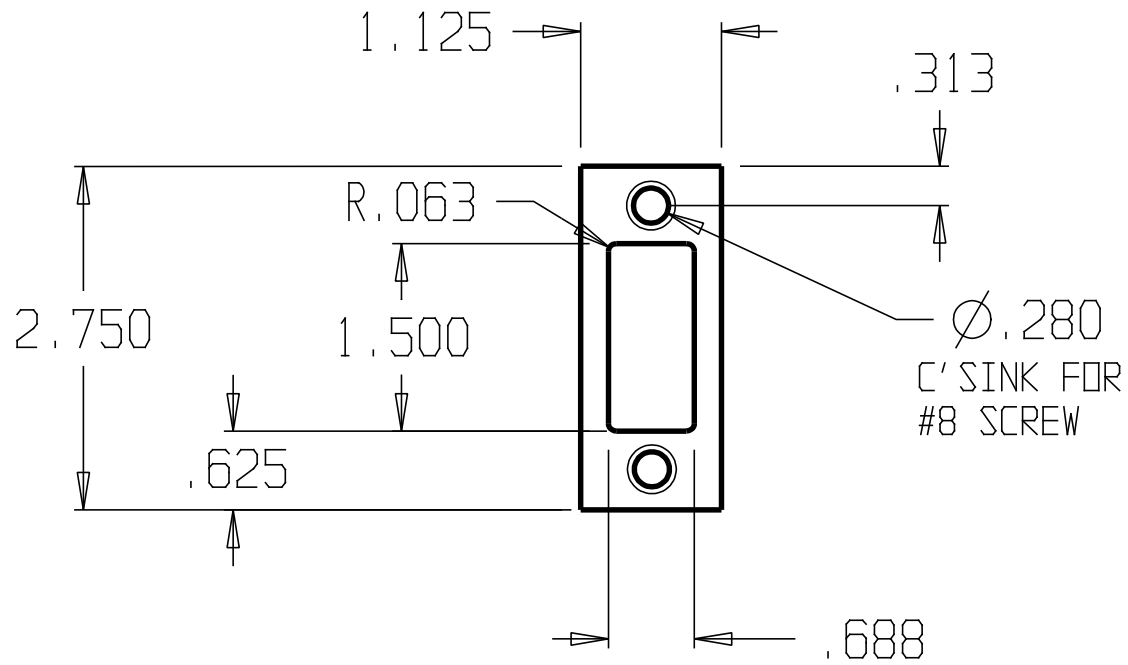

DON-JO MFG. INC.

| | |
|----------|--|
| DESIGNER | |
| APPROVED | |

| | | | |
|-------|--------------|----------|-------|
| SIZE | DATE: | PART NO. | REV |
| A | 5/12/04 | DS-234 | |
| SCALE | RELEASE DATE | WEIGHT | SHEET |
| | | | |

| REVISIONS | | | |
|-----------|-----|-----------|------------|
| ZONE | REV | FINISHES: | GUAGE: |
| | | 605 | 13ga. .090 |

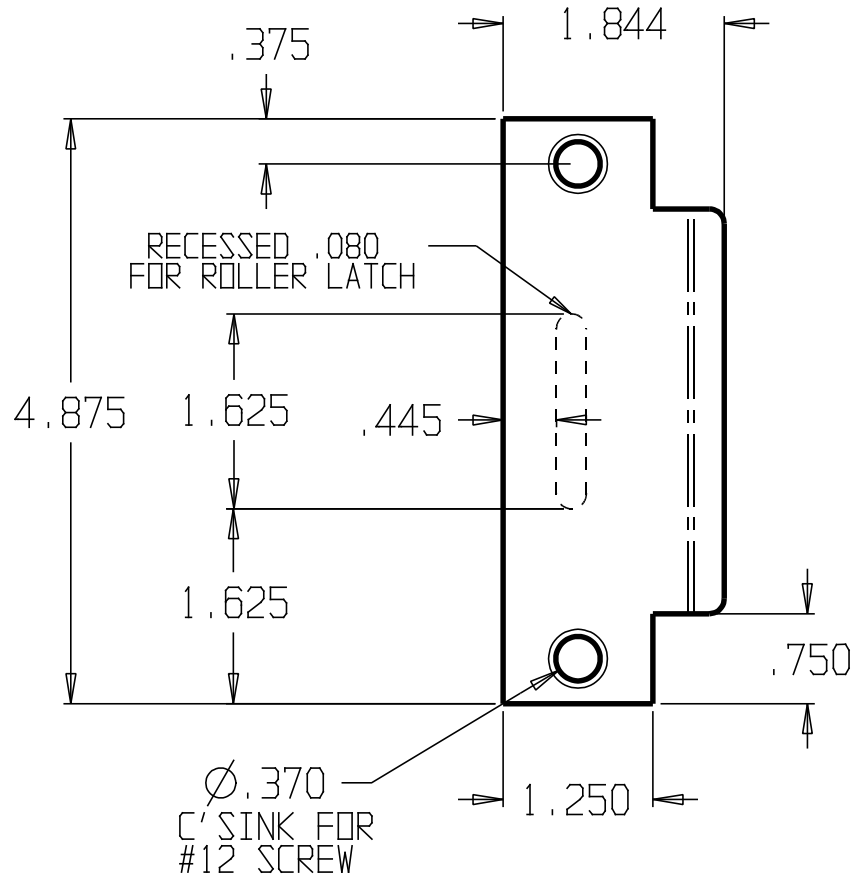

DON-JO MFG. INC.

| | | | | |
|----------|-----------|------------------|---------------------|-------|
| DESIGNER | SIZE A | DATE: 5/12/04 | PART NO. DST-161 | REV |
| APPROVED | SCALE | RELEASE DATE | WEIGHT | SHEET |

| | | |
|---------|----|-----|
| DWG NO. | SH | REV |
|---------|----|-----|

| REVISIONS | | FINISHES: | GUAGE: |
|-----------|-----|----------------|------------|
| ZONE | REV | 605, 609 & 630 | 18ga. .050 |

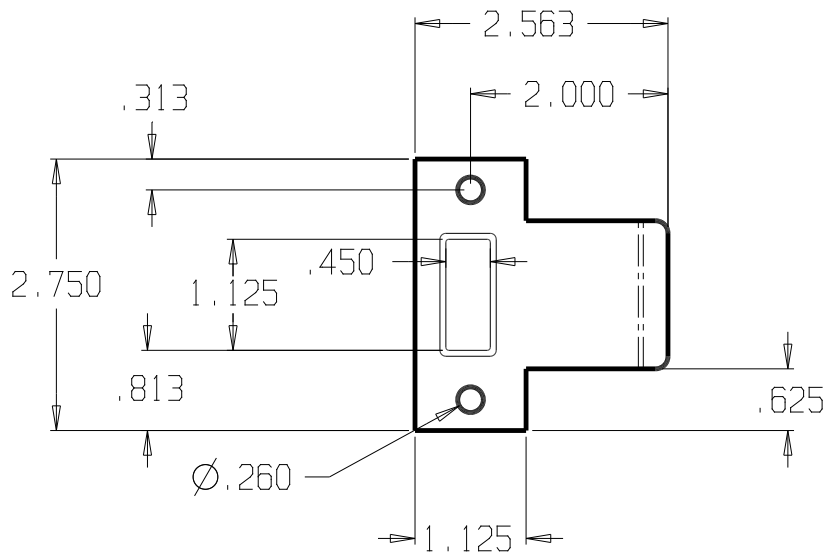

DON-JO MFG. INC.

| | | | | |
|----------|-------|--------------|----------|-------|
| DESIGNER | SIZE | DATE: | PART NO. | REV |
| | A | 8/11/11 | DT-102 | |
| APPROVED | SCALE | RELEASE DATE | WEIGHT | SHEET |

| | | |
|---------|----|-----|
| DWG NO. | SH | REV |
|---------|----|-----|

| REVISIONS | | FINISHES: | GUAGE: |
|-----------|-----|---------------|------------|
| ZONE | REV | 605,609 & 630 | 18ga. .050 |

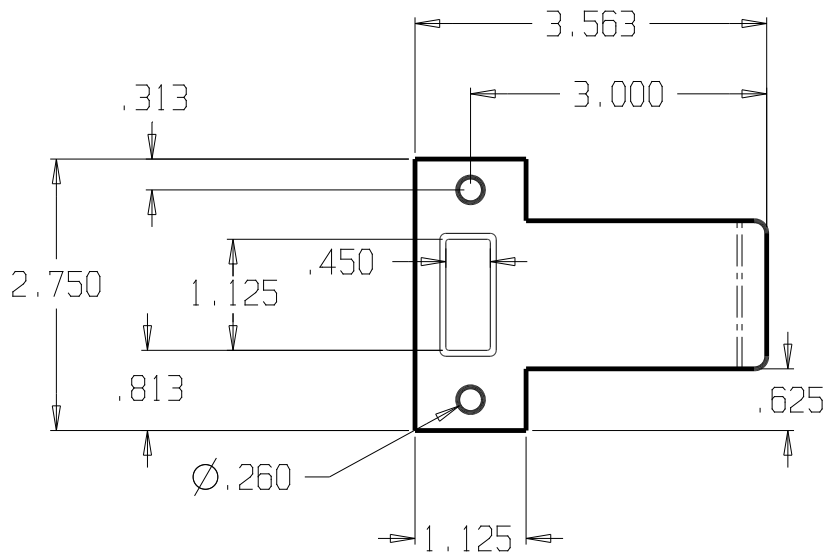

DON-JO MFG. INC.

| | |
|----------|----------|
| DESIGNER | APPROVED |
|----------|----------|

| | | | |
|-----------|------------------|--------------------|-------|
| SIZE A | DATE: 8/11/11 | PART NO. DT-103 | REV |
| SCALE | RELEASE DATE | WEIGHT | SHEET |

| | | |
|---------|----|-----|
| DWG NO. | SH | REV |
|---------|----|-----|

| REVISIONS | | FINISHES: | GUAGE: |
|-----------|-----|----------------|------------|
| ZONE | REV | 605, 609 & 630 | 18ga. .050 |

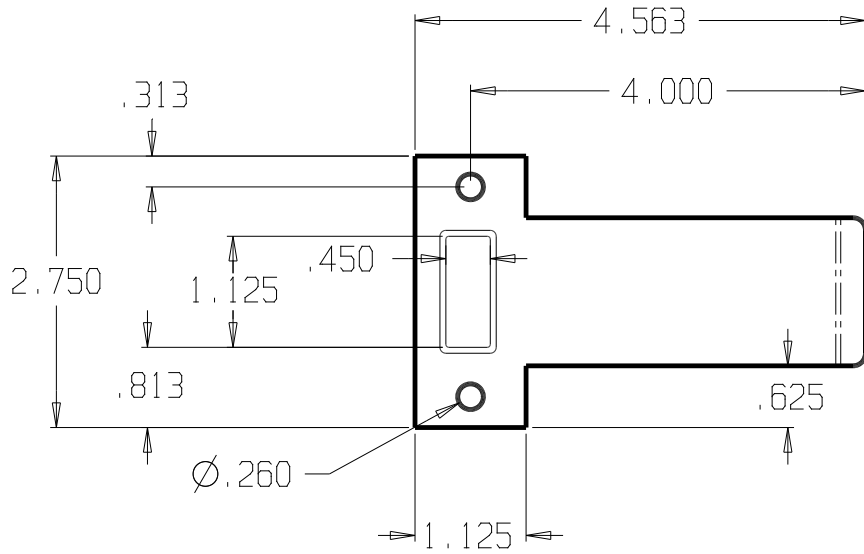

DON-JO MFG. INC.

DESIGNER
APPROVED

| | | | |
|-----------|------------------|--------------------|-------|
| SIZE A | DATE: 8/11/11 | PART NO. DT-104 | REV |
| SCALE | RELEASE DATE | WEIGHT | SHEET |

| | | |
|---------|----|-----|
| DWG NO. | SH | REV |
|---------|----|-----|

| REVISIONS | | FINISHES: | GUAGE: |
|-----------|-----|----------------|------------|
| ZONE | REV | 605, 609 & 630 | 18ga. .050 |

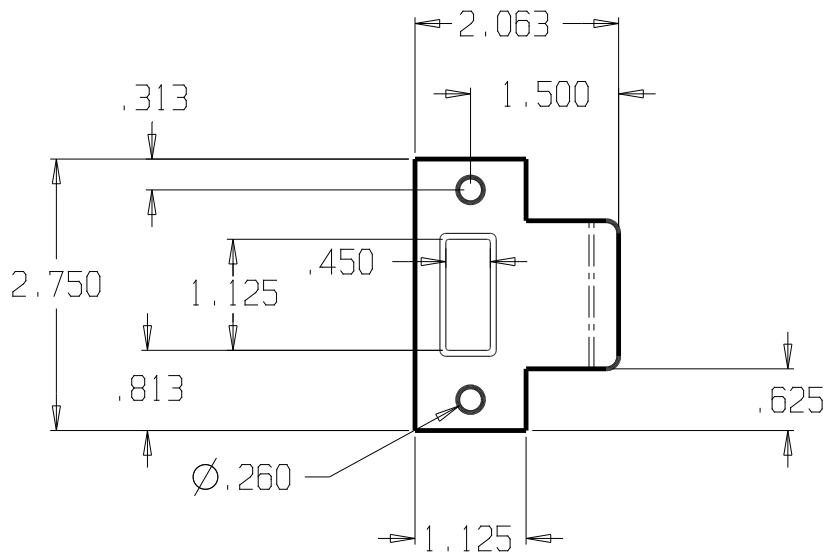

DON-JO MFG. INC.

| | | | | |
|----------|-------|--------------|----------|-------|
| DESIGNER | SIZE | DATE: | PART NO. | REV |
| | A | 8/11/11 | DT-115 | |
| APPROVED | SCALE | RELEASE DATE | WEIGHT | SHEET |

| | | |
|---------|----|-----|
| DWG NO. | SH | REV |
|---------|----|-----|

| REVISIONS | | FINISHES: | GUAGE: |
|-----------|-----|----------------|------------|
| ZONE | REV | 605, 609 & 630 | 18ga. .050 |

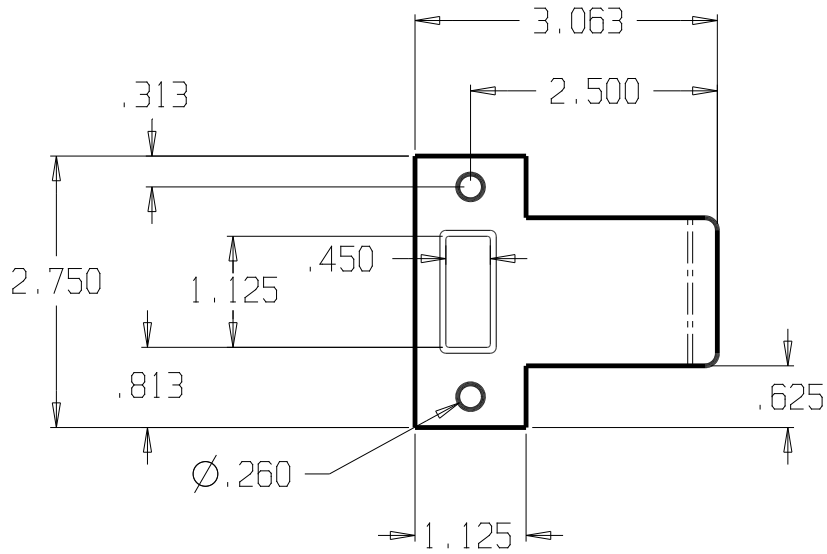

DON-JO MFG. INC.

| | |
|----------|--|
| DESIGNER | |
| APPROVED | |

| | | | |
|-------|--------------|----------|-------|
| SIZE | DATE: | PART NO. | REV |
| A | 8/11/11 | DT-125 | |
| SCALE | RELEASE DATE | WEIGHT | SHEET |

| | | |
|---------|----|-----|
| DWG NO. | SH | REV |
|---------|----|-----|

| REVISIONS | | FINISHES: | GUAGE: |
|-----------|-----|----------------|------------|
| ZONE | REV | 605, 609 & 630 | 18ga. .050 |

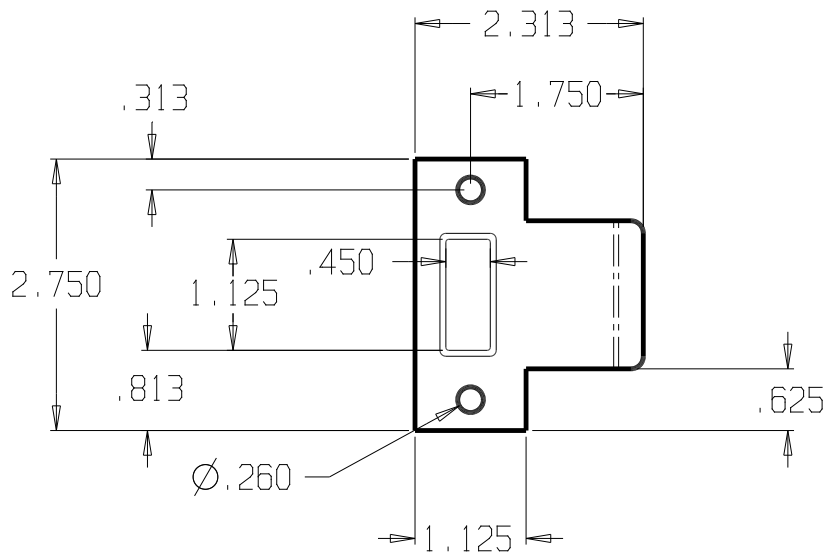

DON-JO MFG. INC.

| | | | | |
|----------|-------|--------------|----------|-------|
| DESIGNER | SIZE | DATE: | PART NO. | REV |
| | A | 8/11/11 | DT-175 | |
| APPROVED | SCALE | RELEASE DATE | WEIGHT | SHEET |

| REVISIONS | | |
|-----------|-----|--|
| ZONE | REV | FINISHES: 605, 609, 619, 620, 630 & DU |
| | | GAUGE: 18ga. .050 |

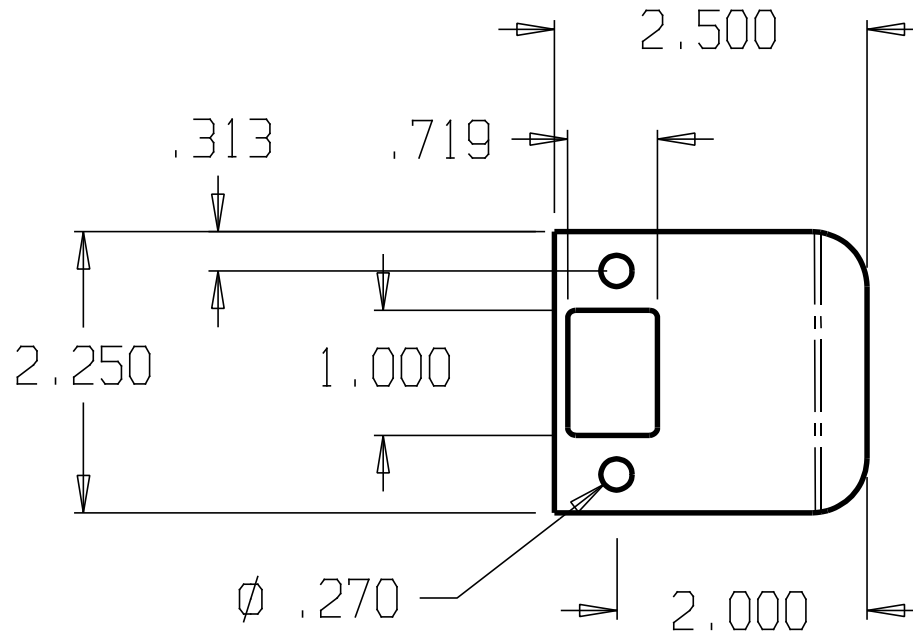

DON-JO MFG. INC.

| | |
|----------|--|
| DESIGNER | |
| APPROVED | |

| | | | |
|---------|---------------|-----------------|-------|
| SIZE: A | DATE: 5/13/04 | PART NO. EL-102 | REV |
| SCALE | RELEASE DATE | WEIGHT | SHEET |

| REVISIONS | | |
|-----------|-----|--|
| ZONE | REV | FINISHES: 605, 609, 619, 620, 630 & DU |
| | | GAUGE: 18ga. .050 |

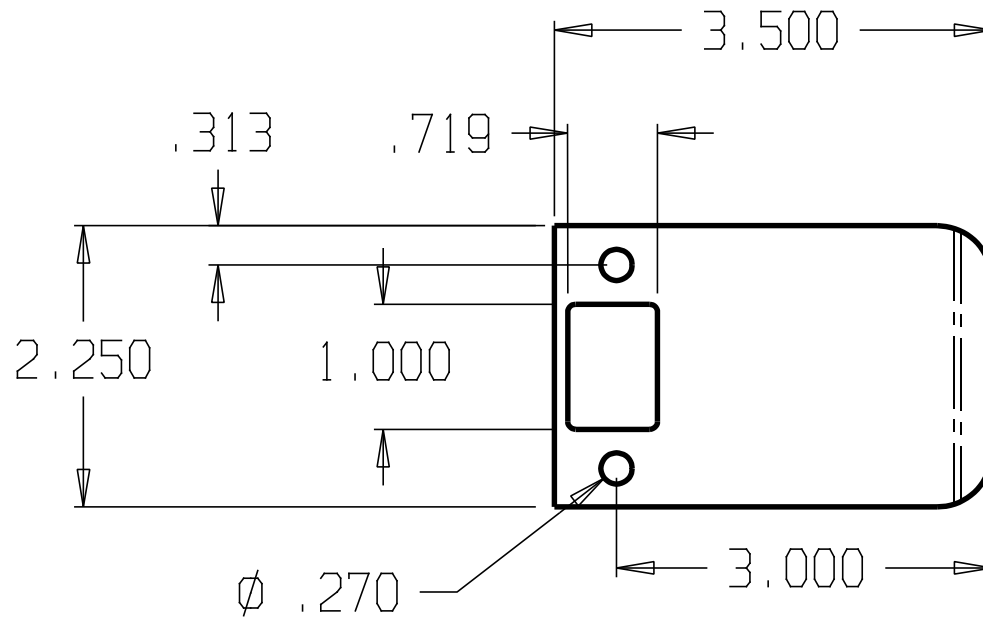

DON-JO MFG. INC.

| | | | | |
|----------|---------|---------------|-----------------|-------|
| DESIGNER | SIZE: A | DATE: 5/13/04 | PART NO. EL-103 | REV |
| APPROVED | SCALE | RELEASE DATE | WEIGHT | SHEET |

| REVISIONS | | |
|-----------|-----|--|
| ZONE | REV | FINISHES: 605, 609, 619, 620, 630 & DU |
| | | GAUGE: 18ga. .050 |

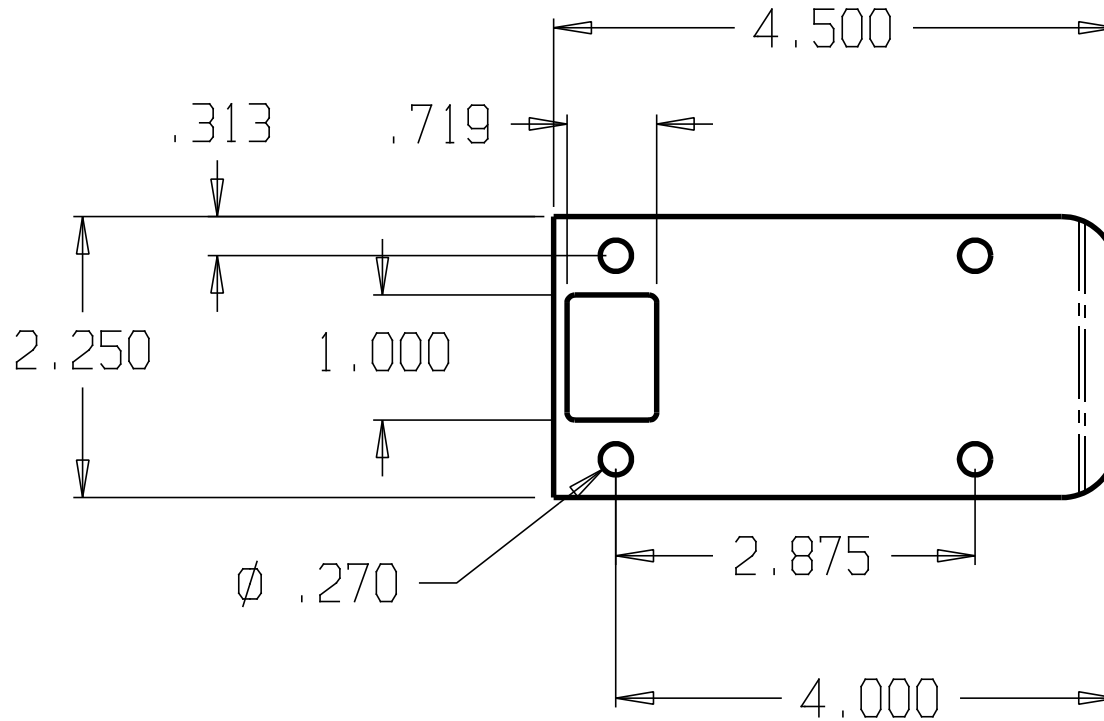

| | | | | | |
|------------------|--|-------|--------------|----------|-------|
| DON-JO MFG. INC. | | SIZE | DATE: | PART NO. | REV |
| DESIGNER | | A | 5/13/04 | EL-104 | |
| APPROVED | | SCALE | RELEASE DATE | WEIGHT | SHEET |

| REVISIONS | | |
|-----------|-----|---------------------------------|
| ZONE | REV | FINISHES: |
| | | 605, 609, 619, 620, 630 & DU |
| | | GAUGE: 18ga. .050 |

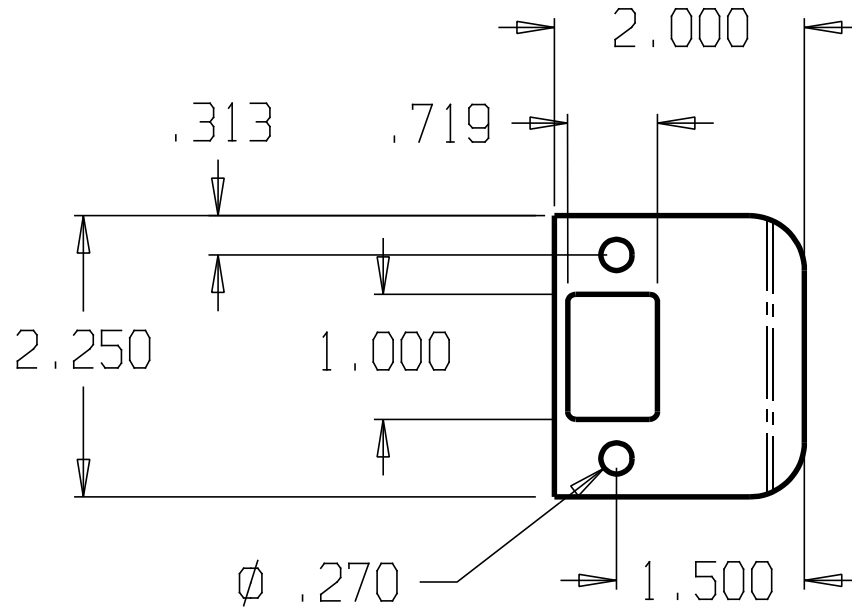

DON-JO MFG. INC.

| | | | | |
|----------|---------|---------------|-----------------|-------|
| DESIGNER | SIZE: A | DATE: 5/13/04 | PART NO. EL-115 | REV |
| APPROVED | SCALE | RELEASE DATE | WEIGHT | SHEET |

| REVISIONS | | |
|-----------|-----|--|
| ZONE | REV | FINISHES: 605, 609, 619, 620, 630 & DU |
| | | GAUGE: 18ga. .050 |

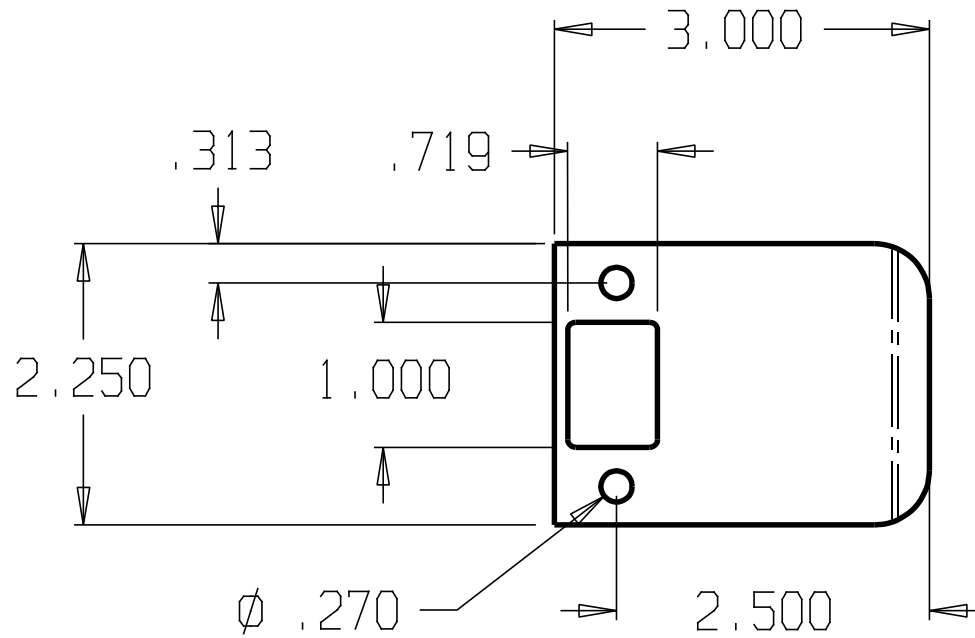

DON-JO MFG. INC.

| | |
|----------|--|
| DESIGNER | |
| APPROVED | |

| | | | |
|---------|---------------|-----------------|-------|
| SIZE: A | DATE: 5/13/04 | PART NO. EL-125 | REV |
| SCALE | RELEASE DATE | WEIGHT | SHEET |

| REVISIONS | | |
|-----------|-----|--|
| ZONE | REV | FINISHES: 605, 609, 619, 620, 630 & DU |
| | | GAUGE: 18ga. .050 |

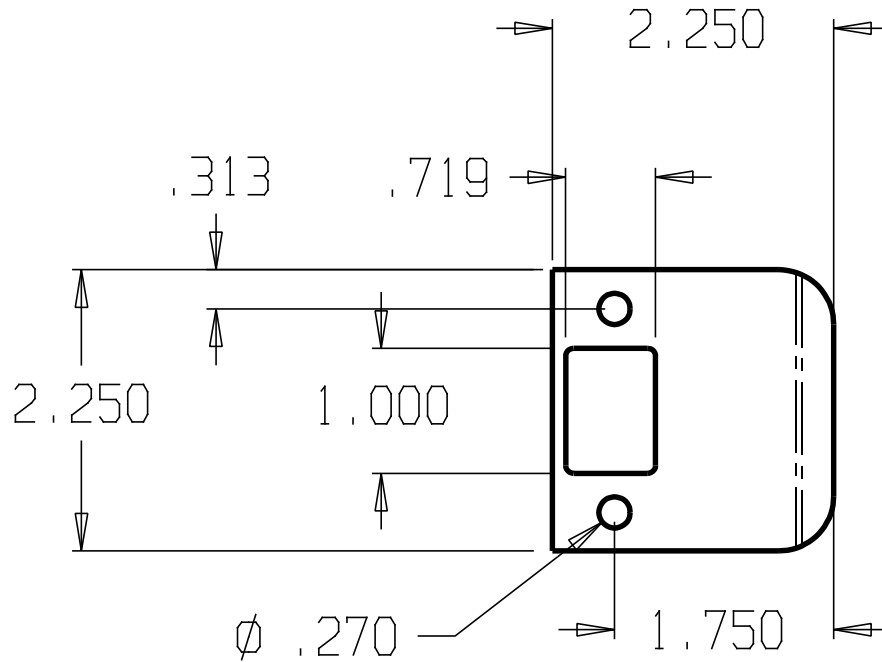

DON-JO MFG. INC.

| | | | | |
|----------|--------|---------------|-----------------|-------|
| DESIGNER | SIZE A | DATE: 5/13/04 | PART NO. EL-175 | REV |
| APPROVED | SCALE | RELEASE DATE | WEIGHT | SHEET |

| REVISIONS | | |
|-----------|-----|------------|
| ZONE | REV | FINISHES: |
| | | BP |
| | | GAUGE: |
| | | 13ga. .090 |

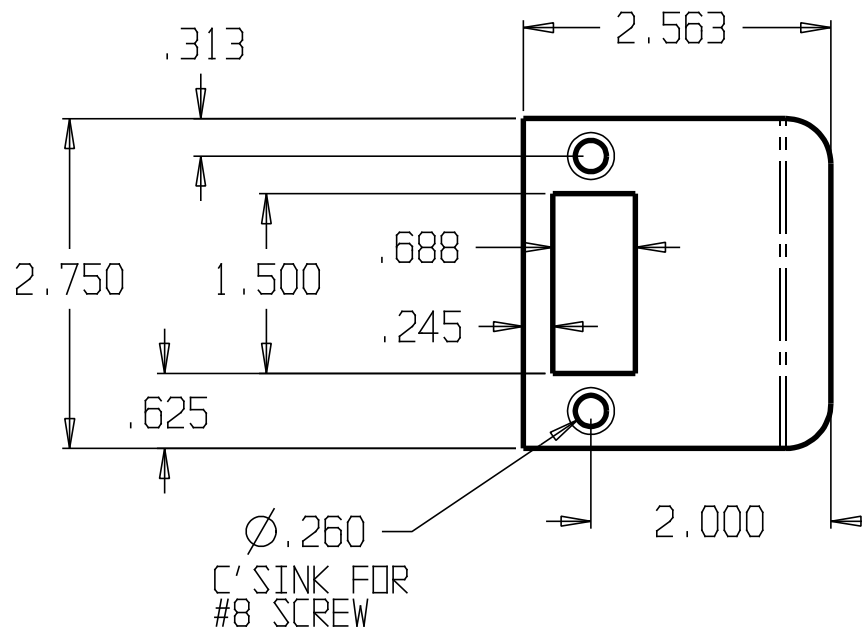

| | | | | | | | |
|------------------|--|-------|--------------|--------|-------|----------|-----|
| DON-JO MFG. INC. | | | | SIZE | DATE: | PART NO. | REV |
| DESIGNER | | A | 5/13/04 | EL-202 | | | |
| APPROVED | | SCALE | RELEASE DATE | WEIGHT | SHEET | | |

| REVISIONS | | | |
|-----------|-----|-----------|------------|
| ZONE | REV | FINISHES: | GAUGE: |
| | | BP | 13ga. .090 |

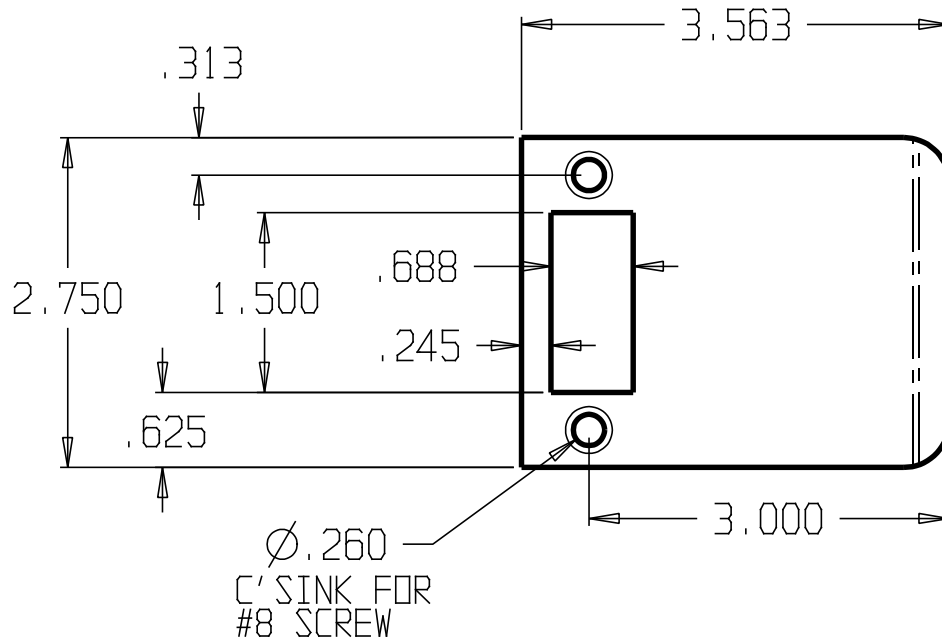

| | | | | | | | |
|------------------|--|-------|--------------|--------|-------|----------|-----|
| DON-JO MFG. INC. | | | | SIZE | DATE: | PART NO. | REV |
| DESIGNER | | A | 5/13/04 | EL-203 | | | |
| APPROVED | | SCALE | RELEASE DATE | WEIGHT | SHEET | | |

| REVISIONS | | | |
|-----------|-----|-----------|------------|
| ZONE | REV | FINISHES: | GAUGE: |
| | | BP | 13ga. .090 |

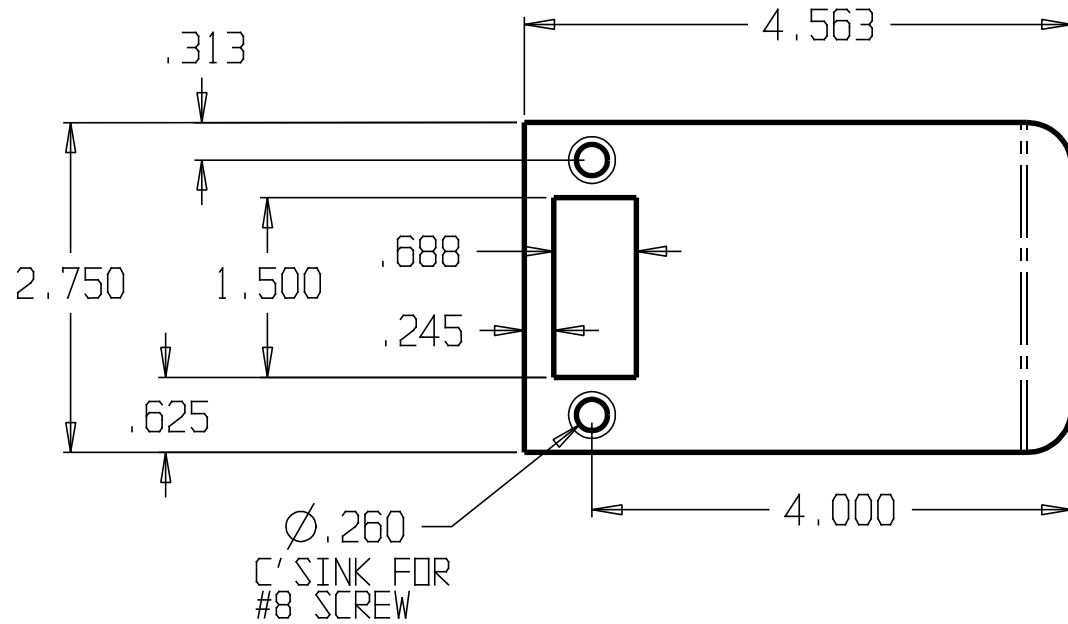

| | | | | | | | |
|------------------|--|-------|--------------|--------|-------|----------|-----|
| DON-JO MFG. INC. | | | | SIZE | DATE: | PART NO. | REV |
| DESIGNER | | A | 5/13/04 | EL-204 | | | |
| APPROVED | | SCALE | RELEASE DATE | WEIGHT | SHEET | | |

| REVISIONS | | | |
|-----------|-----|-----------|------------|
| ZONE | REV | FINISHES: | GAUGE: |
| | | BP | 13ga. .090 |

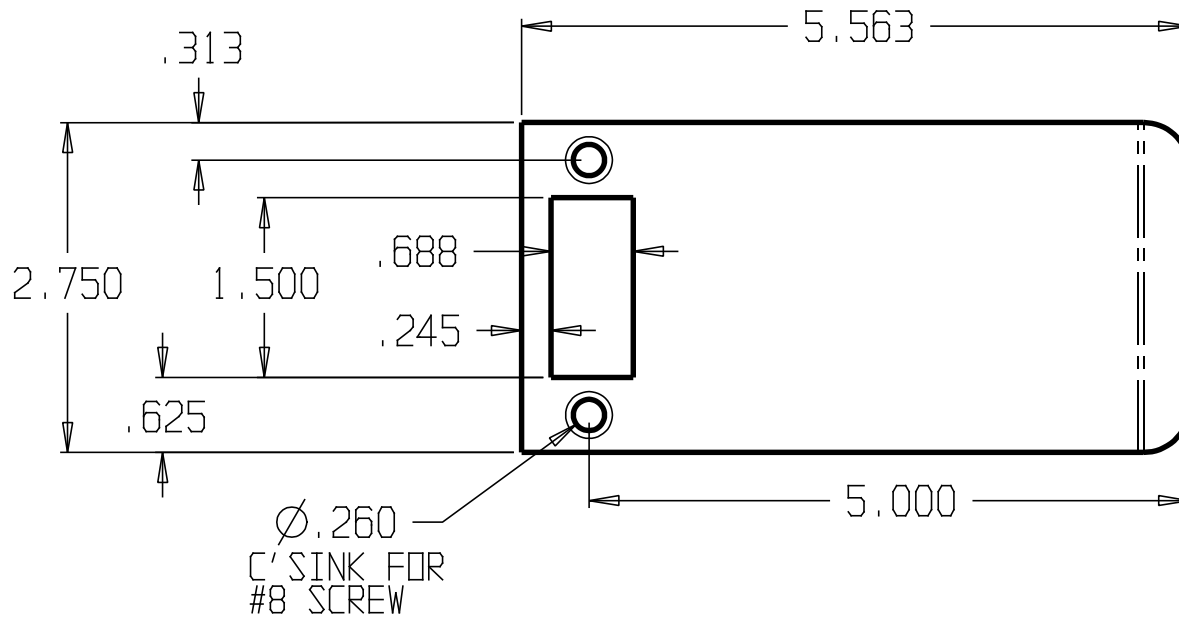

| | | | | | | | |
|------------------|--|-------|--------------|--------|-------|----------|-----|
| DON-JO MFG. INC. | | | | SIZE | DATE: | PART NO. | REV |
| DESIGNER | | A | 5/13/04 | EL-205 | | | |
| APPROVED | | SCALE | RELEASE DATE | WEIGHT | SHEET | | |

| REVISIONS | | | |
|-----------|-----|-----------|------------|
| ZONE | REV | FINISHES: | GAUGE: |
| | | BP | 13ga. .090 |

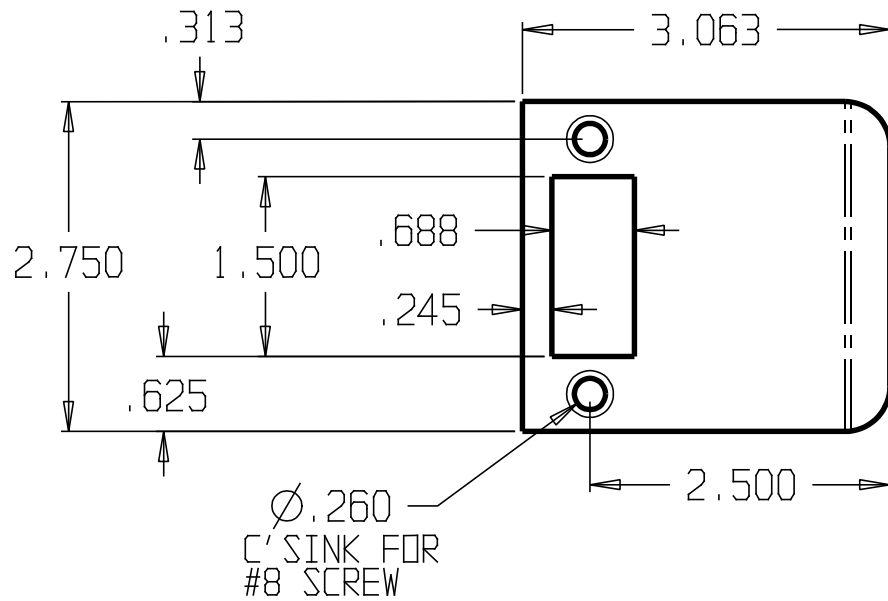

| | |
|------------------|--|
| DON-JO MFG. INC. | |
| DESIGNER | |
| APPROVED | |

| | | | |
|-------|--------------|----------|-------|
| SIZE | DATE: | PART NO. | REV |
| A | 5/13/04 | EL-225 | |
| SCALE | RELEASE DATE | WEIGHT | SHEET |

| REVISIONS | | | |
|-----------|-----|---------------|------------|
| ZONE | REV | FINISHES: | GALUGE: |
| | | 605,612 & 630 | 13ga. .090 |

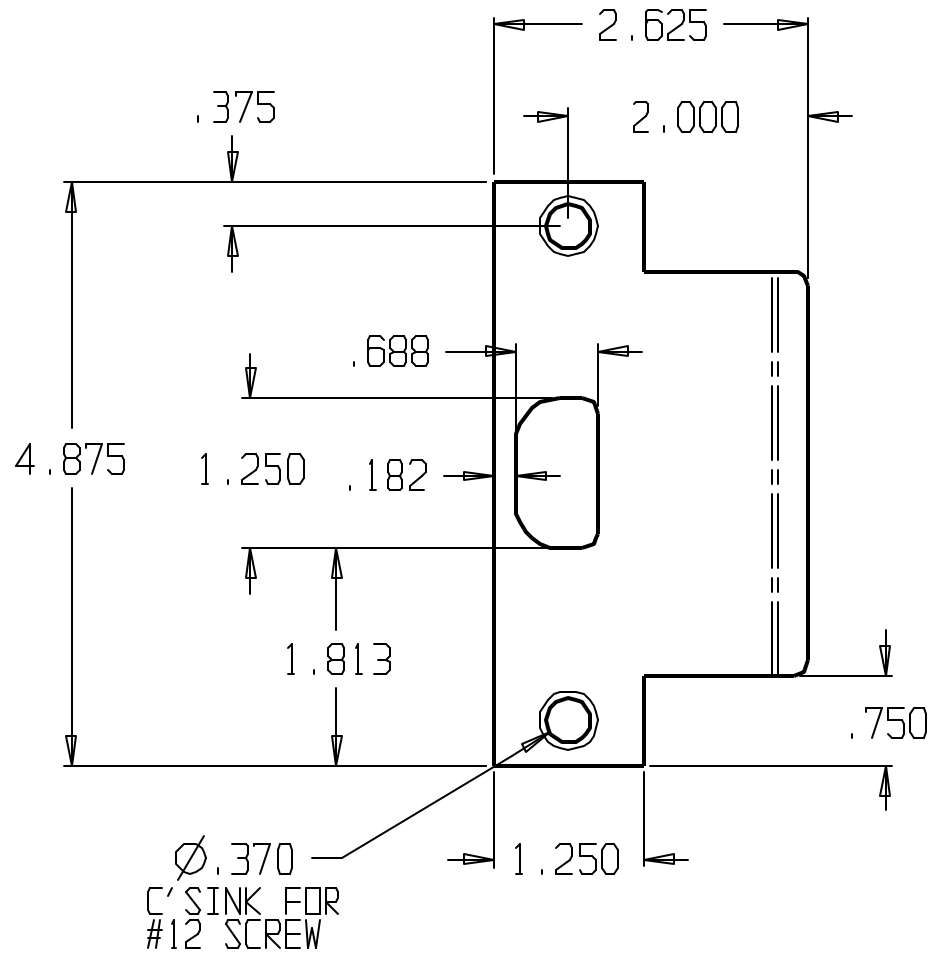

| | | | | | |
|------------------|--|-------|--------------|----------|-------|
| DON-JO MFG. INC. | | SIZE | DATE: | PART NO. | REV |
| DESIGNER | | A | 5/17/04 | EST-102 | |
| APPROVED | | SCALE | RELEASE DATE | WEIGHT | SHEET |

| REVISIONS | | | |
|-----------|-----|----------------|------------|
| ZONE | REV | FINISHES: | GUAGE: |
| | | 605, 612 & 630 | 13ga. .090 |

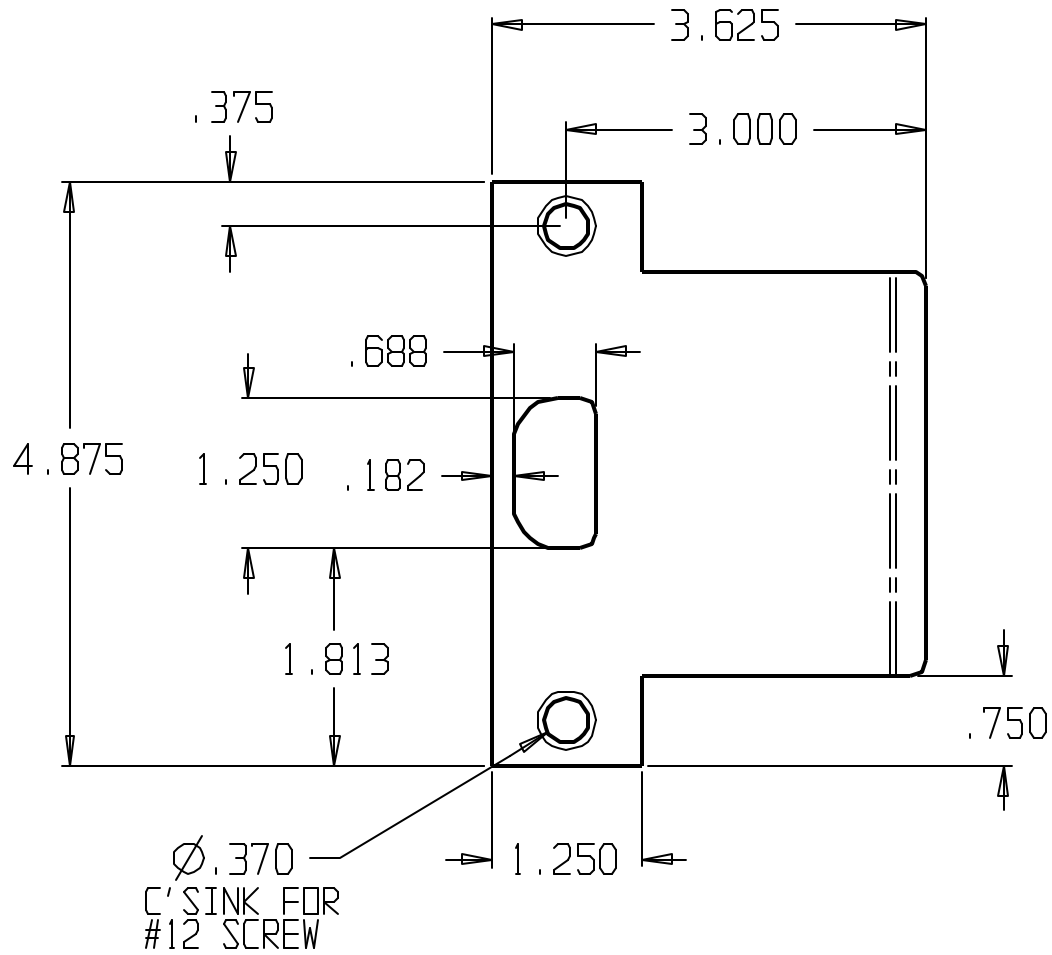

| | | | | | |
|------------------|--|-------|--------------|----------|-------|
| DON-JO MFG. INC. | | SIZE | DATE: | PART NO. | REV |
| DESIGNER | | A | 5/17/04 | EST-103 | |
| APPROVED | | SCALE | RELEASE DATE | WEIGHT | SHEET |

| REVISIONS | | | |
|-----------|-----|----------------|------------|
| ZONE | REV | FINISHES: | GALUGE: |
| | | 605, 612 & 630 | 13ga. .090 |

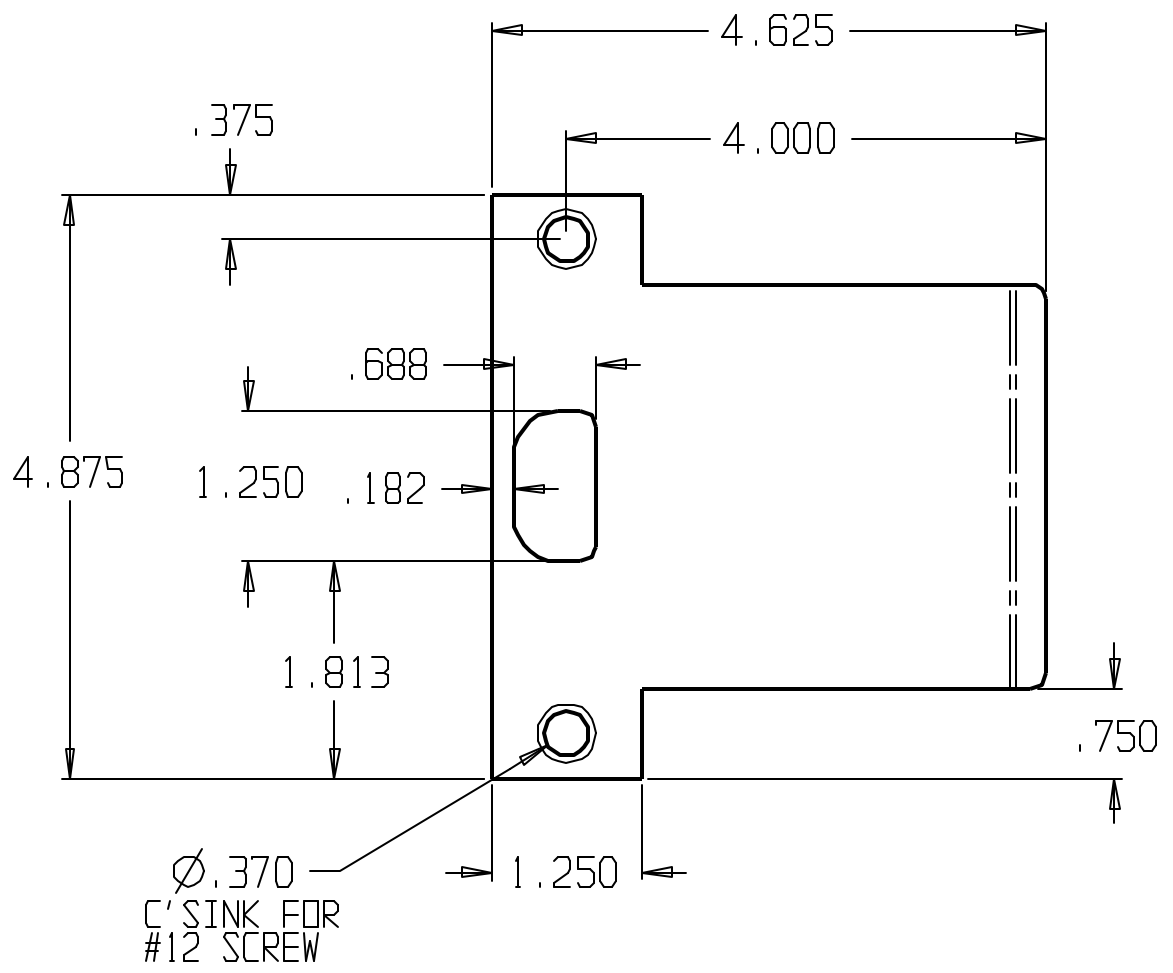

DON-JO MFG. INC.

| | | | | |
|----------|-------|--------------|----------|-------|
| DESIGNER | SIZE | DATE: | PART NO. | REV |
| | A | 5/17/04 | EST-104 | |
| APPROVED | SCALE | RELEASE DATE | WEIGHT | SHEET |

| REVISIONS | | | |
|-----------|-----|----------------|------------|
| ZONE | REV | FINISHES: | GALUGE: |
| | | 605, 612 & 630 | 13ga. .090 |

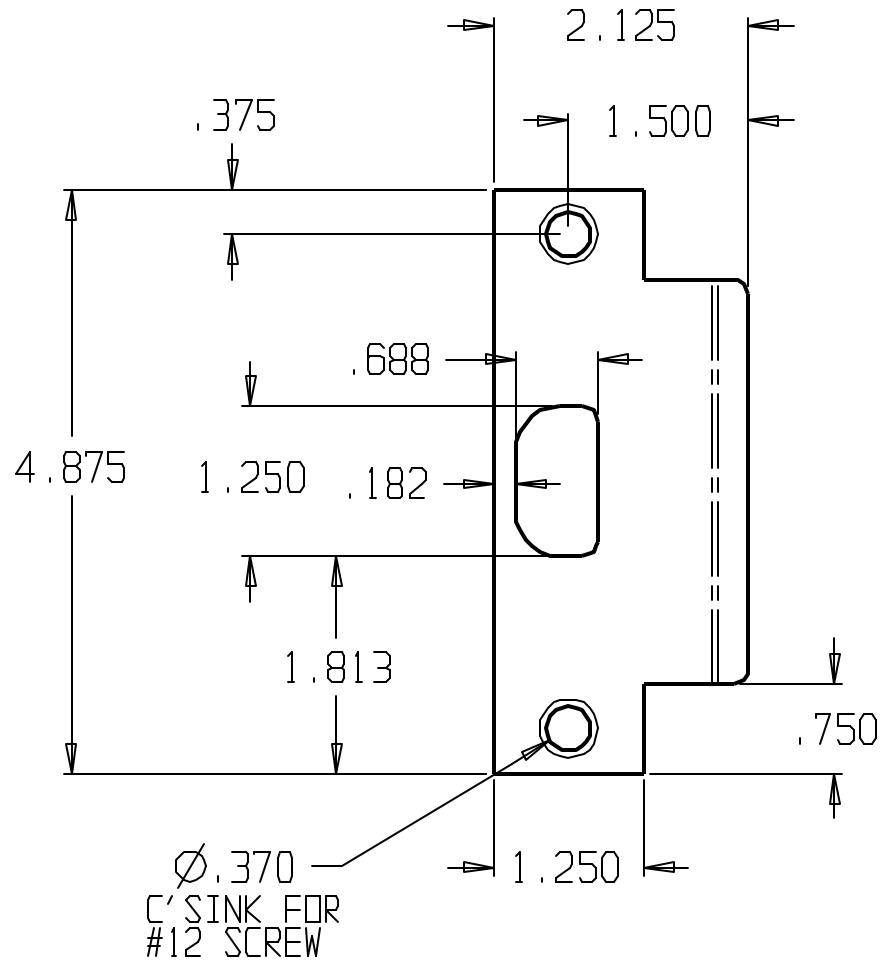

DON-JO MFG. INC.

| | | | | |
|----------|-----------|------------------|---------------------|-------|
| DESIGNER | SIZE A | DATE: 5/17/04 | PART NO. EST-115 | REV |
| APPROVED | SCALE | RELEASE DATE | WEIGHT | SHEET |

| REVISIONS | | | |
|-----------|-----|---------------|------------|
| ZONE | REV | FINISHES: | GALUGE: |
| | | 605,612 & 630 | 13ga. .090 |

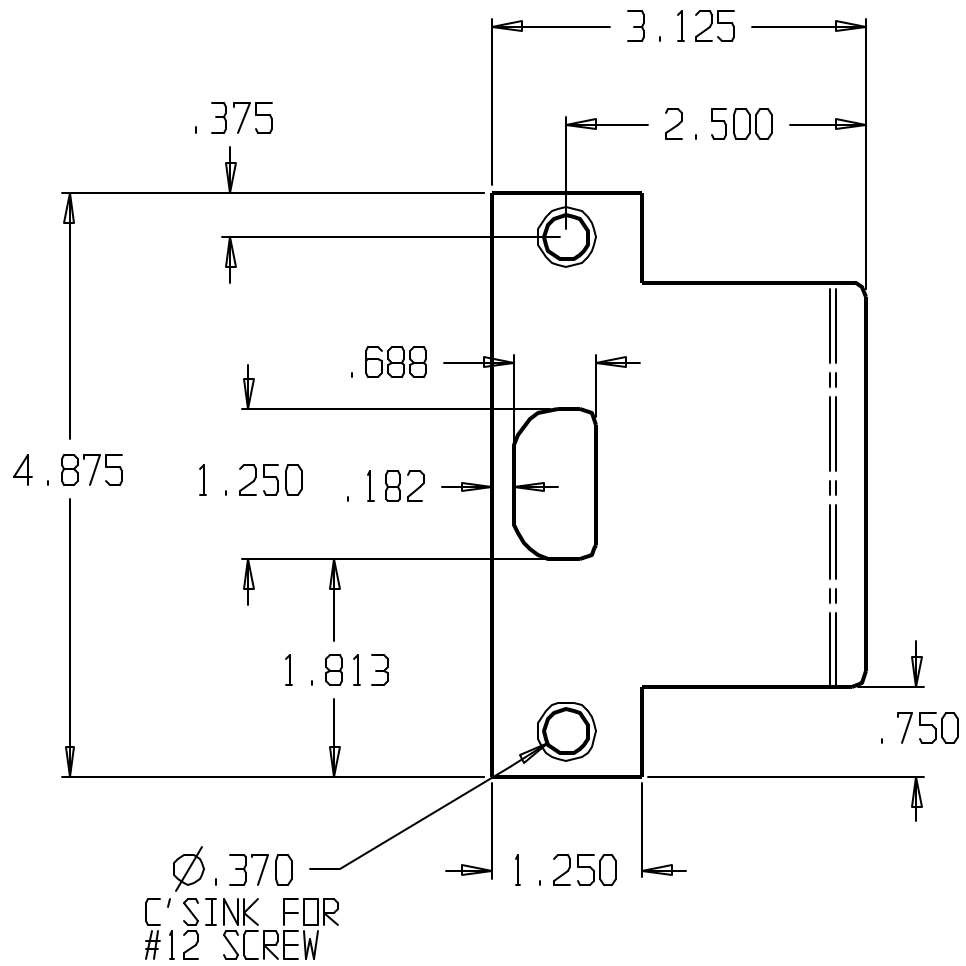

| | | | | | |
|------------------|--|-------|--------------|----------|-------|
| DON-JO MFG. INC. | | SIZE | DATE: | PART NO. | REV |
| DESIGNER | | A | 5/17/04 | EST-125 | |
| APPROVED | | SCALE | RELEASE DATE | WEIGHT | SHEET |

| REVISIONS | | | |
|-----------|-----|----------------|------------|
| ZONE | REV | FINISHES: | GALUGE: |
| | | 605, 612 & 630 | 13ga. .090 |

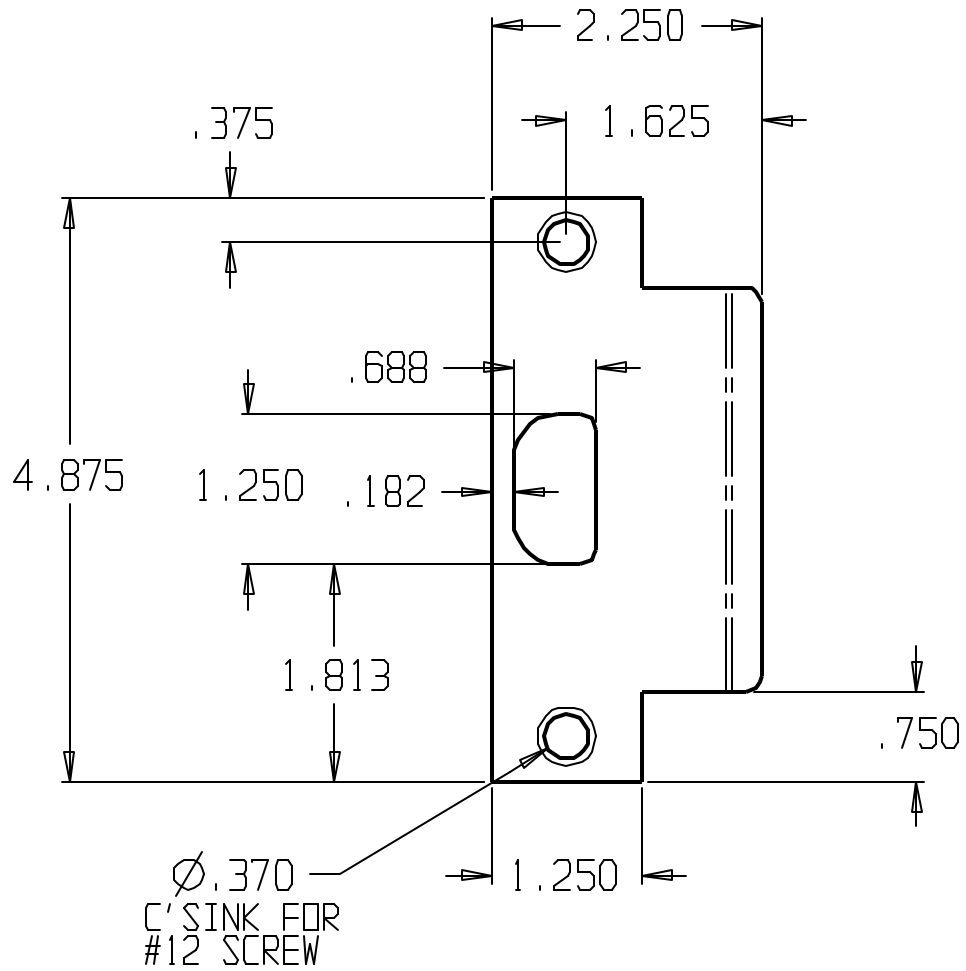

DON-JO MFG. INC.

DESIGNER
APPROVED

SIZE: A
DATE: 5/17/04

PART NO. EST-158
REV

SCALE
RELEASE DATE
WEIGHT
SHEET

| REVISIONS | | | |
|-----------|-----|---------------|------------|
| ZONE | REV | FINISHES: | GALUGE: |
| | | 605,612 & 630 | 13ga. .090 |

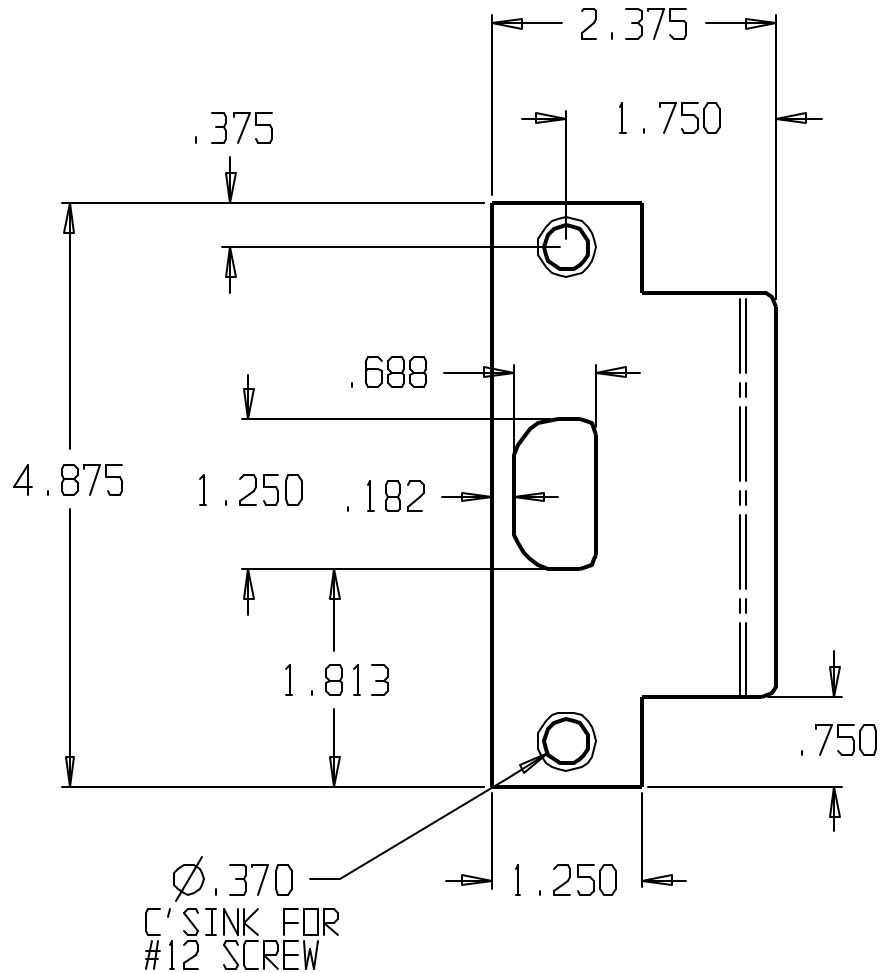

DON-JO MFG. INC.

DESIGNER
APPROVED

SIZE: A
DATE: 5/17/04

PART NO. EST-175
REV

SCALE
RELEASE DATE
WEIGHT
SHEET

| REVISIONS | | | |
|-----------|-----|----------------|-----------|
| ZONE | REV | FINISHES: | GUAGE: |
| | | 605, 609 & 630 | 18ga .050 |

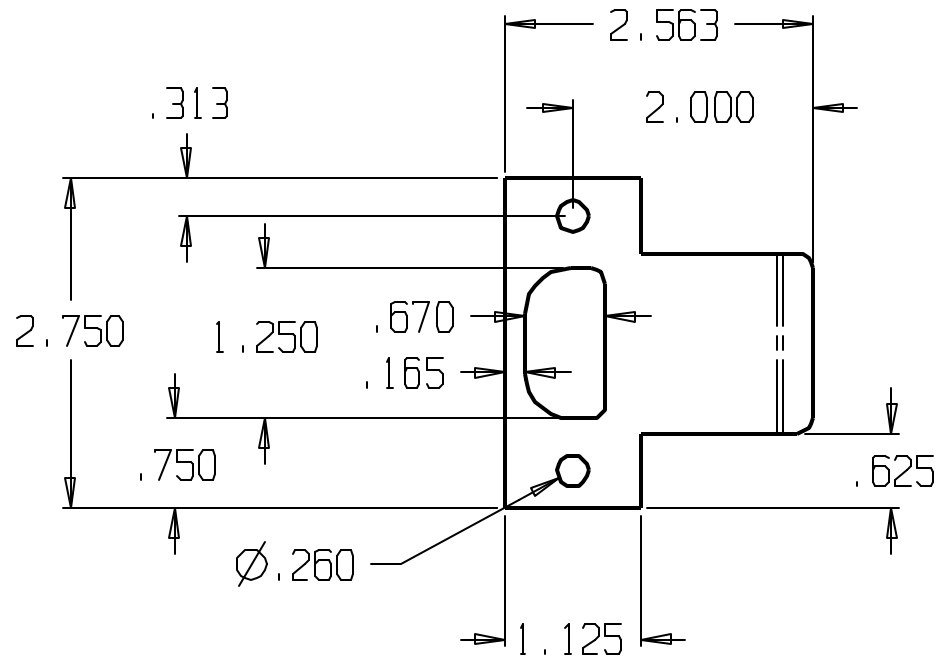

DON-JO MFG. INC.

DESIGNER
APPROVED

SIZE
A

DATE:
8/11/11

PART NO.
ETS-102

REV

SCALE

RELEASE DATE

WEIGHT

SHEET

| REVISIONS | | |
|-----------|-----|----------------|
| ZONE | REV | FINISHES: |
| | | 605, 609 & 630 |
| | | GALUGE: |
| | | 18ga .050 |

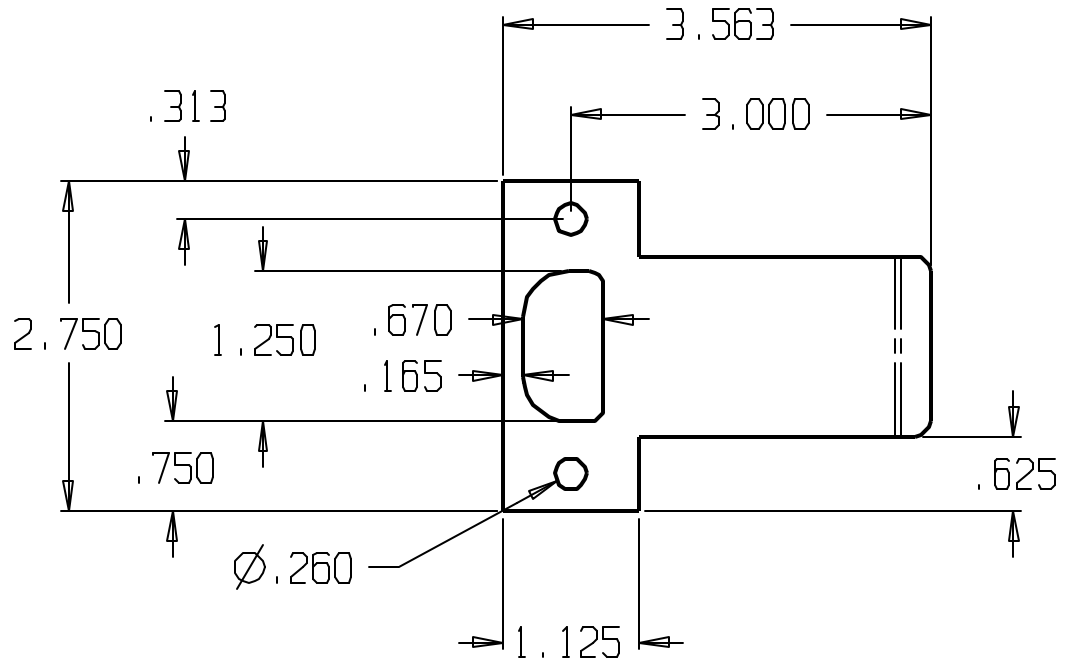

DON-JO MFG. INC.

| | | | | |
|----------|-------|--------------|----------|-------|
| DESIGNER | SIZE | DATE: | PART NO. | REV |
| | A | 5/17/04 | ETS-103 | |
| APPROVED | SCALE | RELEASE DATE | WEIGHT | SHEET |
| | | | | |

| REVISIONS | | | |
|-----------|-----|----------------|------------|
| ZONE | REV | FINISHES: | GALUGE: |
| | | 605, 609 & 630 | 18ga. .050 |

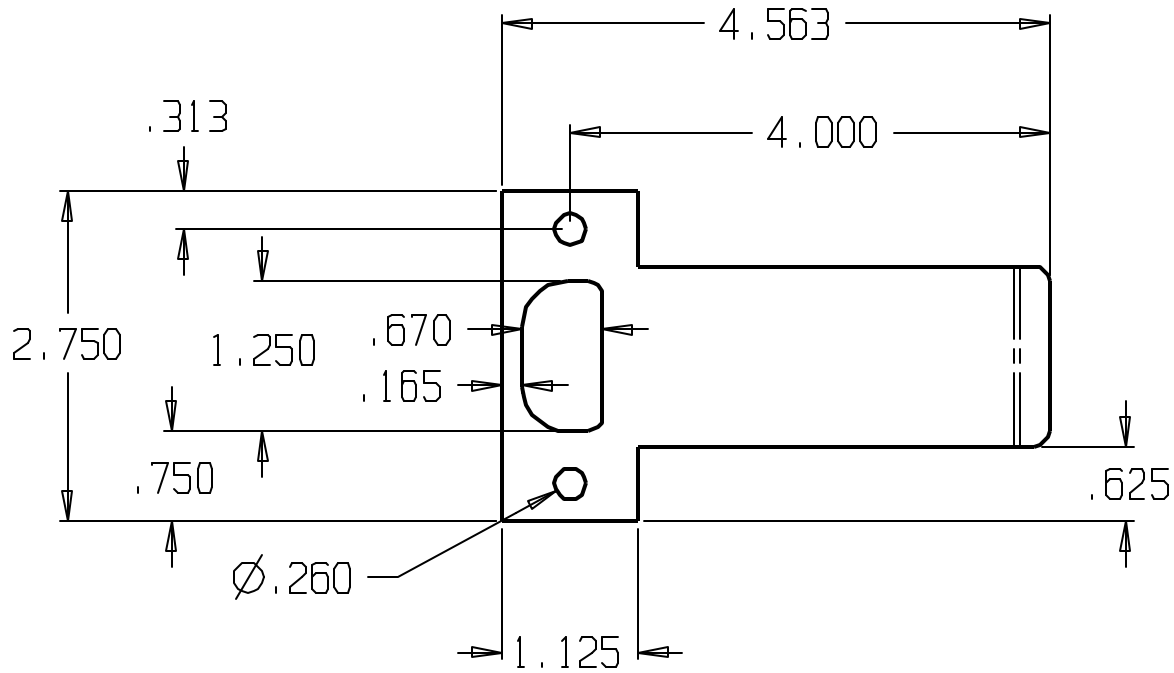

DON-JO MFG. INC.

| | |
|----------|--|
| DESIGNER | |
| APPROVED | |

| | | | |
|-----------|------------------|---------------------|-------|
| SIZE A | DATE: 8/11/11 | PART NO. ETS-104 | REV |
| SCALE | RELEASE DATE | WEIGHT | SHEET |

| REVISIONS | | | |
|-----------|-----|----------------|------------|
| ZONE | REV | FINISHES: | GALUGE: |
| | | 605, 609 & 630 | 18ga. .050 |

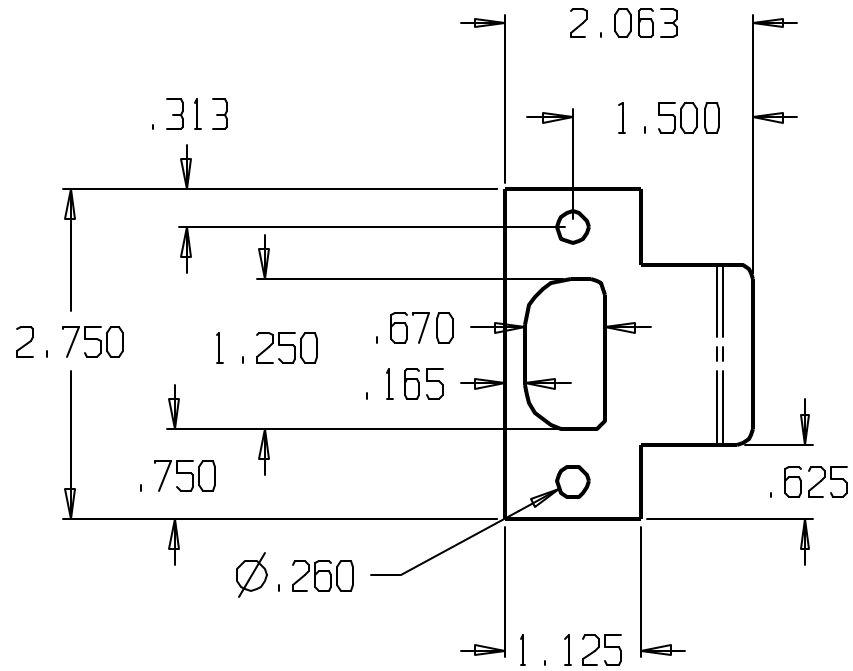

DON-JO MFG. INC.

| | | | | |
|----------|-------|--------------|----------|-------|
| DESIGNER | SIZE | DATE: | PART NO. | REV |
| | A | 8/11/11 | ETS-115 | |
| APPROVED | SCALE | RELEASE DATE | WEIGHT | SHEET |
| | | | | |

| REVISIONS | | | |
|-----------|-----|----------------|------------|
| ZONE | REV | FINISHES: | GALUGE: |
| | | 605, 609 & 630 | 18ga. .050 |

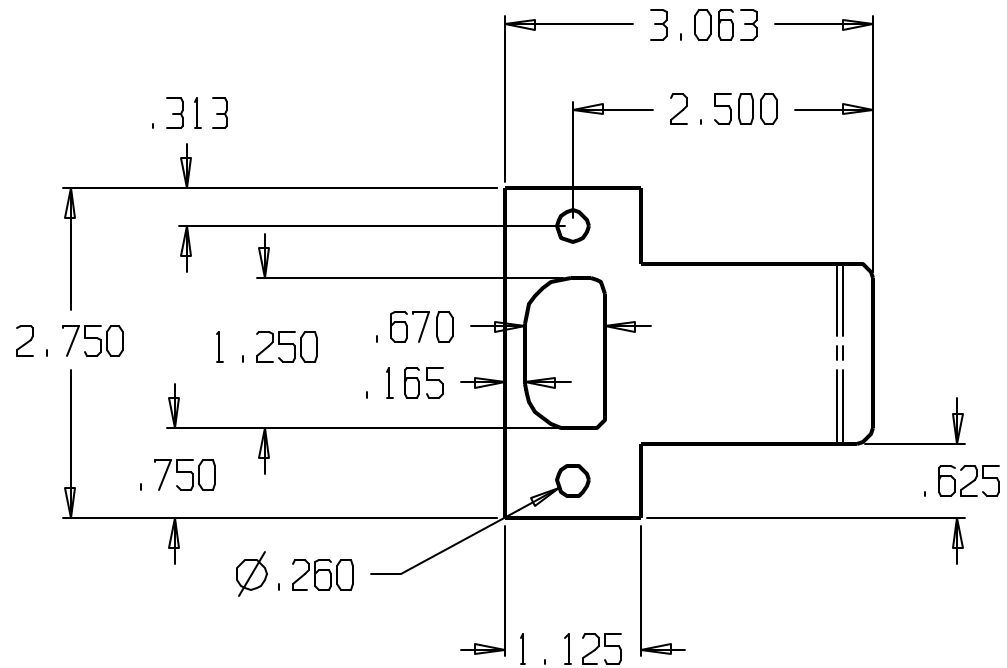

DON-JO MFG. INC.

| | | | | |
|----------|-------|--------------|----------|-------|
| DESIGNER | SIZE | DATE: | PART NO. | REV |
| | A | 8/11/11 | ETS-125 | |
| APPROVED | SCALE | RELEASE DATE | WEIGHT | SHEET |
| | | | | |

| REVISIONS | | | |
|-----------|-----|----------------|-----------|
| ZONE | REV | FINISHES: | GALUGE: |
| | | 605, 609 & 630 | 18ga .050 |

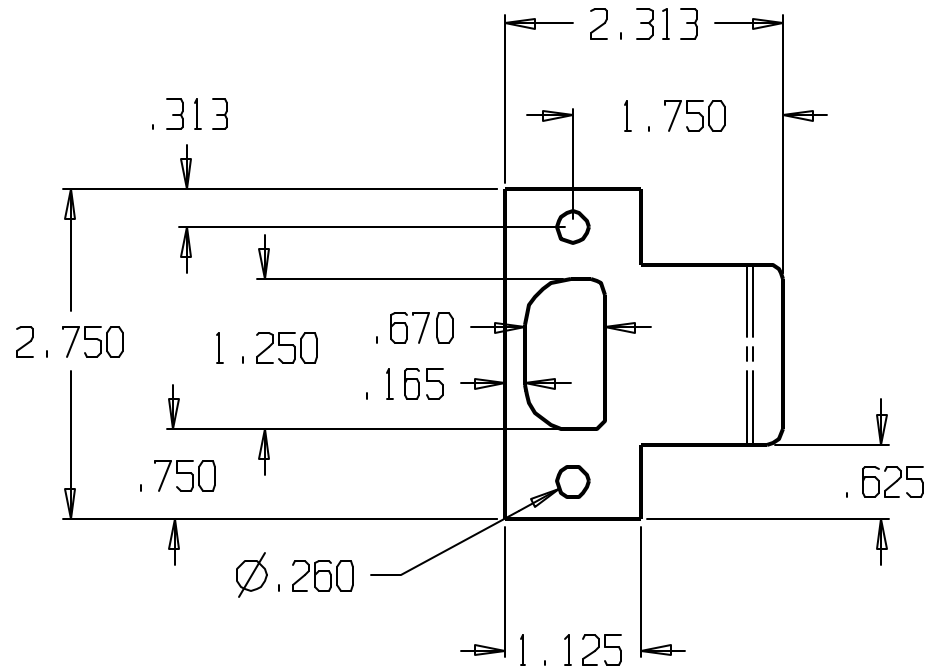

DON-JO MFG. INC.

| | | | | |
|----------|-------|--------------|----------|-------|
| DESIGNER | SIZE | DATE: | PART NO. | REV |
| | A | 8/11/11 | ETS-175 | |
| APPROVED | SCALE | RELEASE DATE | WEIGHT | SHEET |

| REVISIONS | | |
|-----------|-----|------------|
| ZONE | REV | FINISHES: |
| | | BP |
| | | GUAGE: |
| | | 13ga. .090 |

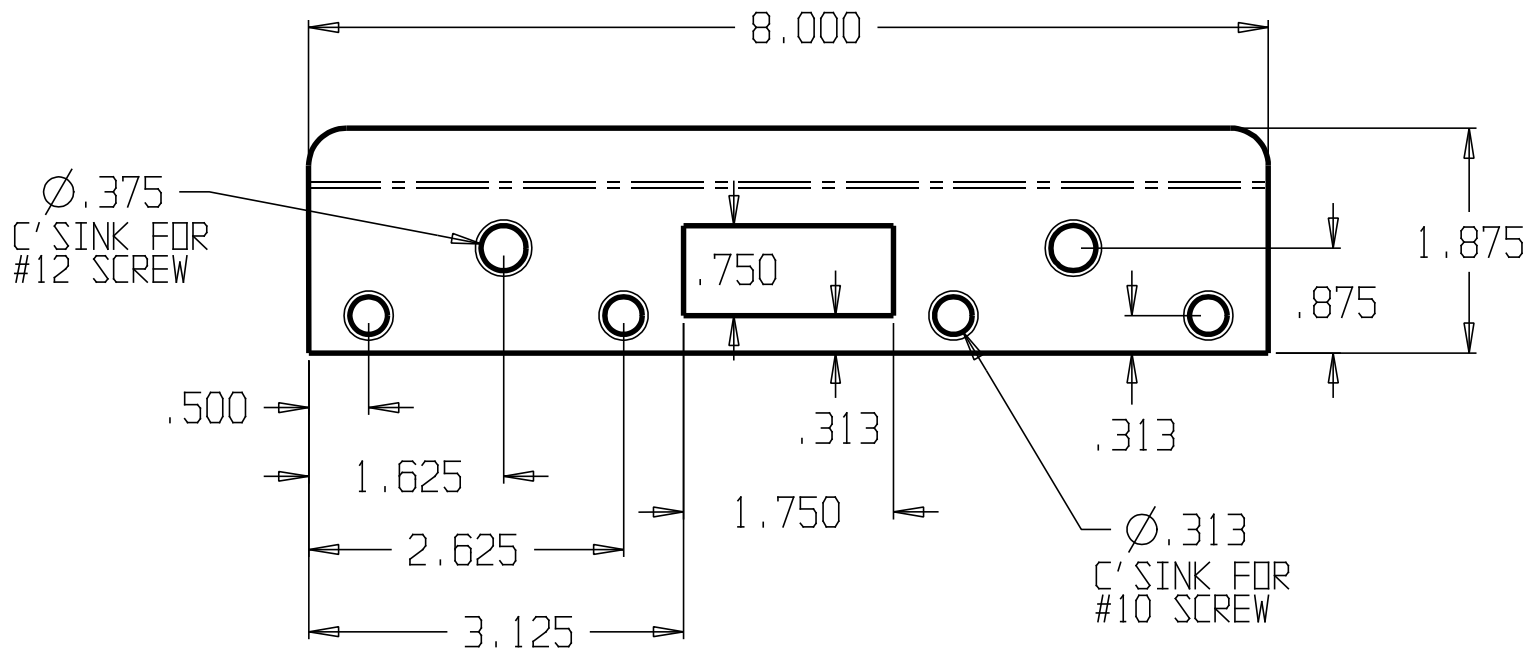

DON-JO MFG. INC.

| | |
|----------|--|
| DESIGNER | |
| APPROVED | |

| | | | |
|-------|--------------|----------|-------|
| SIZE | DATE: | PART NO. | REV |
| A | 5/19/04 | FL-208N | |
| SCALE | RELEASE DATE | WEIGHT | SHEET |
| | | | |

| REVISIONS | | |
|-----------|-----|------------|
| ZONE | REV | FINISHES: |
| | | BP |
| | | GAUGE: |
| | | 13ga. .090 |

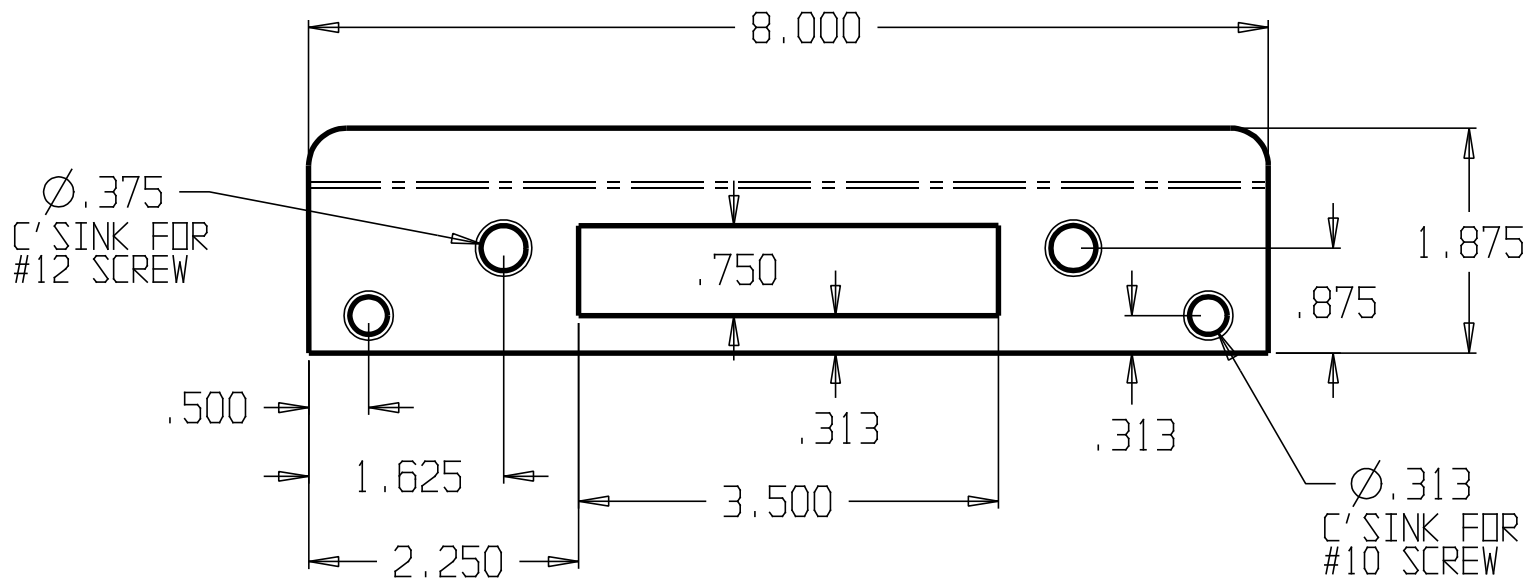

DON-JO MFG. INC.

DESIGNER
APPROVED

| | | |
|-------|--------------|----------|
| SIZE | DATE: | PART NO. |
| A | 5/19/04 | FL-208NM |
| SCALE | RELEASE DATE | WEIGHT |
| | | SHEET |

| |
|-----|
| REV |
| |

| REVISIONS | | |
|-----------|-----|-------------|
| ZONE | REV | FINISHES: |
| | | BP, SL & WH |
| | | GAUGE: |
| | | 13ga. .090 |

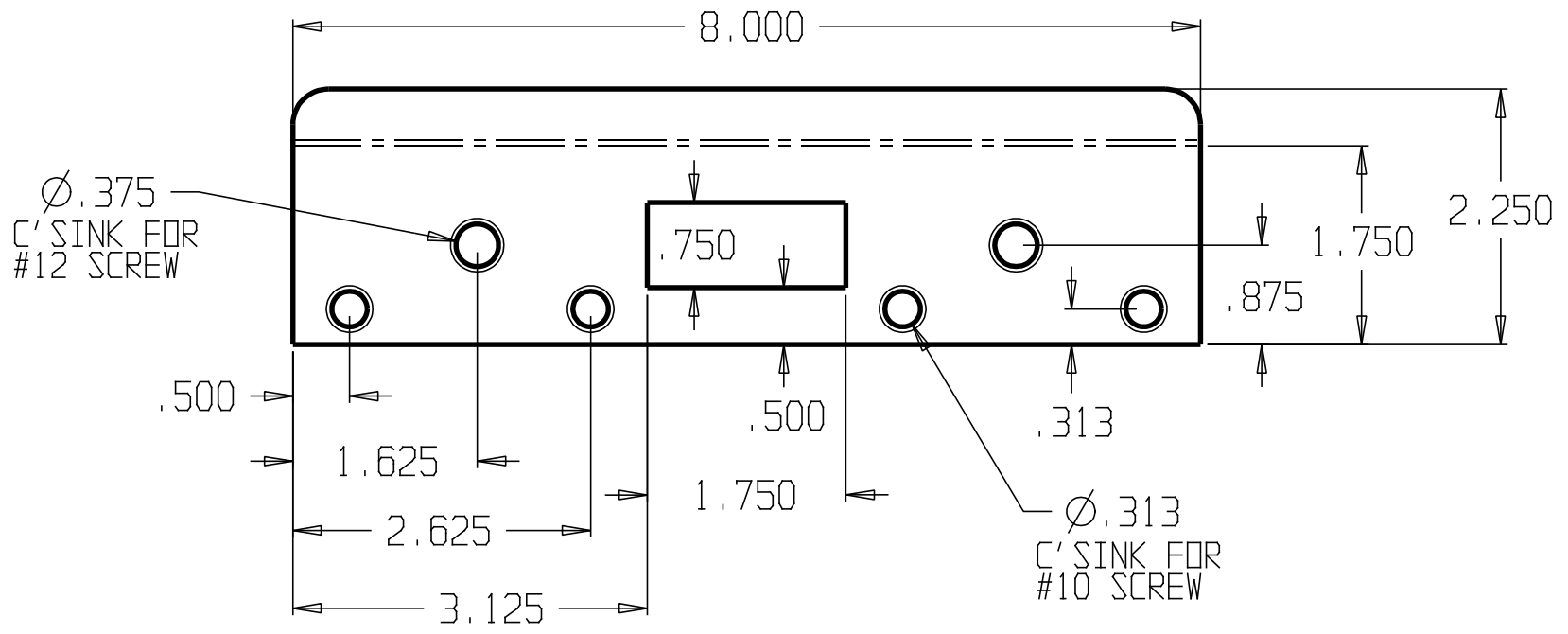

DON-JO MFG. INC.

| | | | | |
|----------|-------|--------------|----------|-------|
| DESIGNER | SIZE | DATE: | PART NO. | REV |
| | A | 5/19/04 | FL-208W | |
| APPROVED | SCALE | RELEASE DATE | WEIGHT | SHEET |
| | | | | |

| REVISIONS | | | |
|-----------|-----|-----------|------------|
| ZONE | REV | FINISHES: | GAUGE: |
| | | BP | 13ga. .090 |

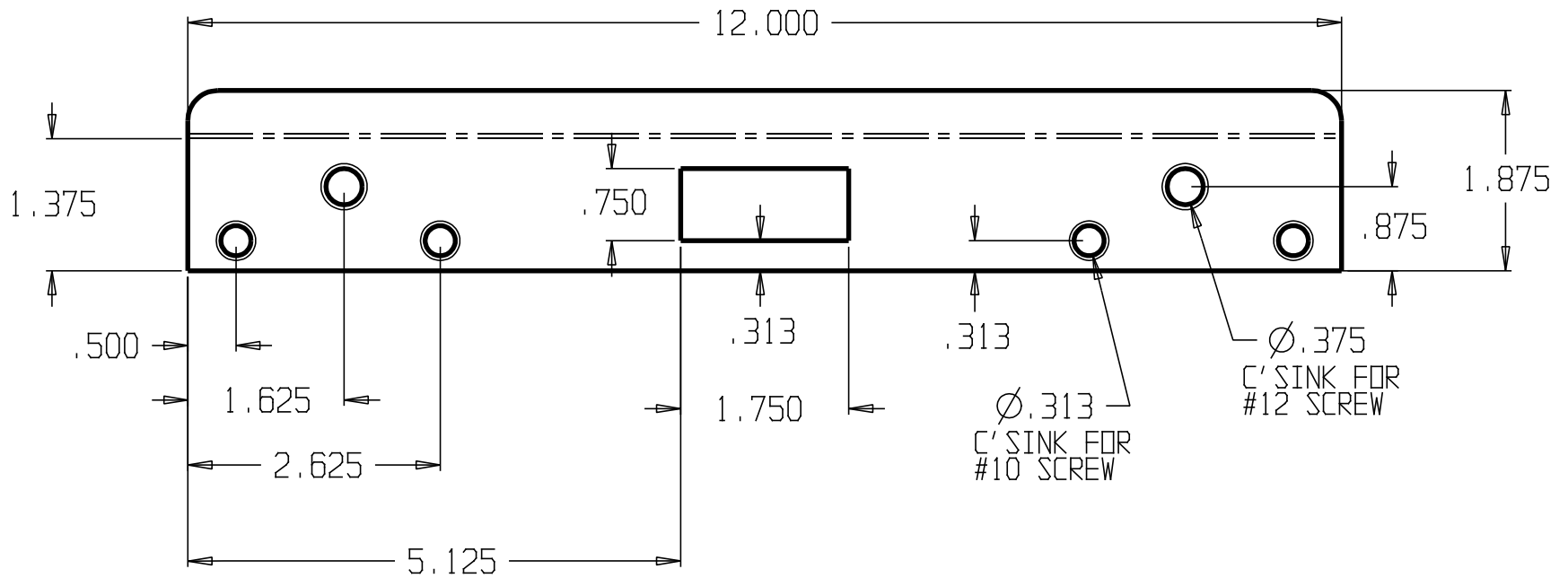

DON-JO MFG. INC.

| | | | | |
|----------|-------|--------------|----------|-------|
| DESIGNER | SIZE | DATE: | PART NO. | REV |
| | A | 5/19/04 | FL-212N | |
| APPROVED | SCALE | RELEASE DATE | WEIGHT | SHEET |
| | | | | |

| REVISIONS | | | |
|-----------|-----|-----------|------------|
| ZONE | REV | FINISHES: | GAUGE: |
| | | BP | 13ga. .090 |

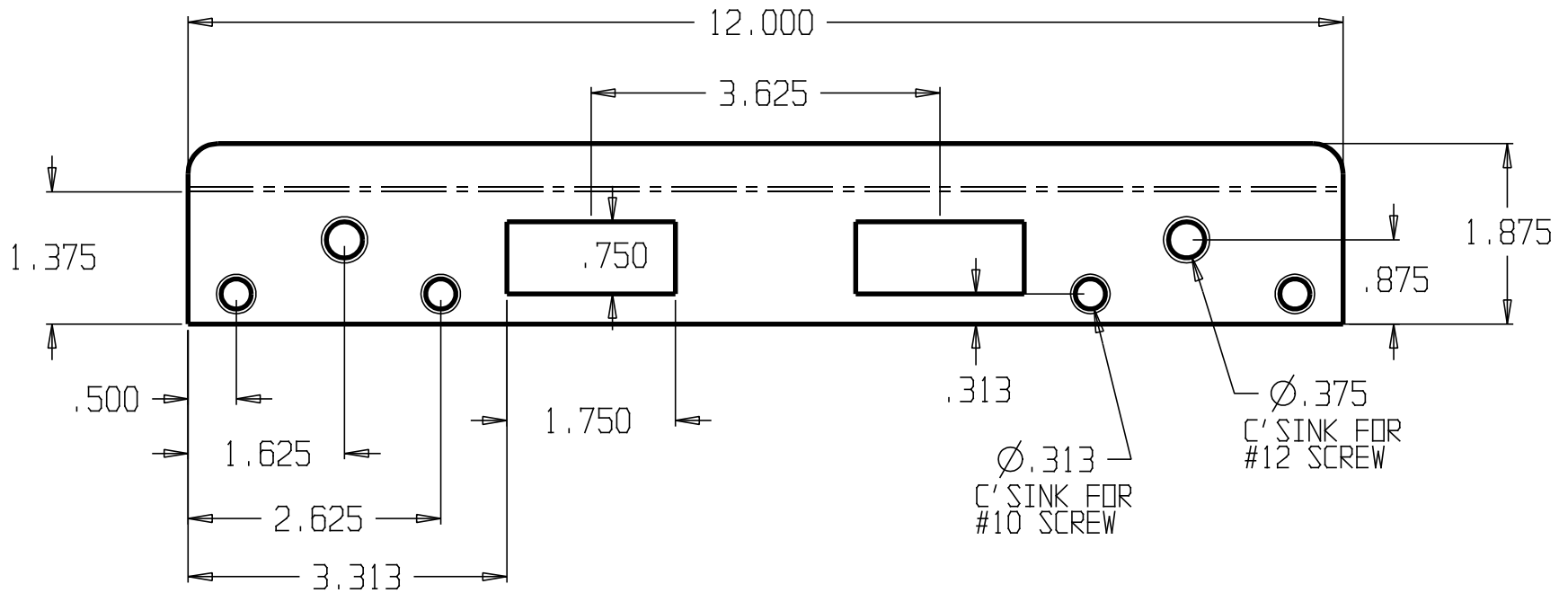

DON-JO MFG. INC.

| | | | | |
|----------|-------|--------------|----------|-------|
| DESIGNER | SIZE | DATE: | PART NO. | REV |
| | A | 5/19/04 | FL-212N4 | |
| APPROVED | SCALE | RELEASE DATE | WEIGHT | SHEET |

| REVISIONS | | | |
|-----------|-----|-----------|------------|
| ZONE | REV | FINISHES: | GAUGE: |
| | | BP | 13ga. .090 |

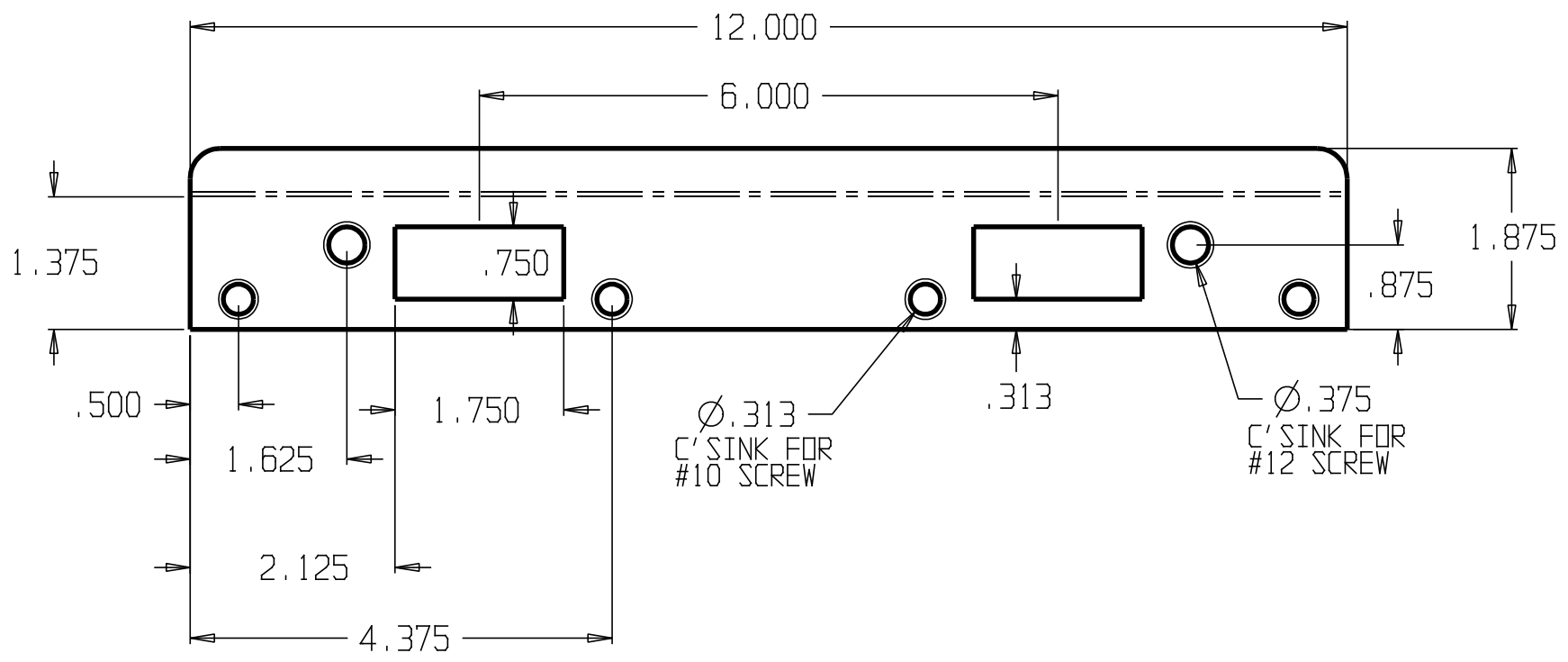

| | | | | | | | |
|------------------|--|-------|--------------|----------|-------|----------|-----|
| DON-JO MFG. INC. | | | | SIZE | DATE: | PART NO. | REV |
| DESIGNER | | A | 5/19/04 | FL-212N6 | | | |
| APPROVED | | SCALE | RELEASE DATE | WEIGHT | SHEET | | |

| REVISIONS | | | |
|-----------|-----|-----------|------------|
| ZONE | REV | FINISHES: | GAUGE: |
| | | BP | 13ga. .090 |

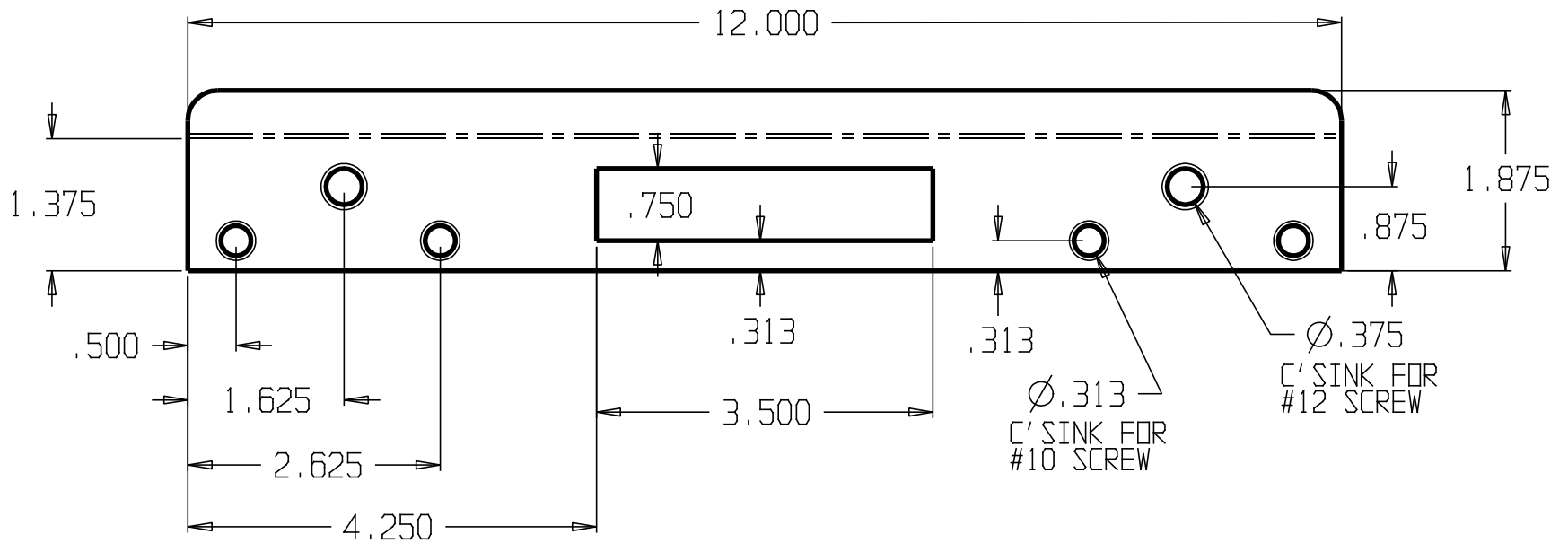

DON-JO MFG. INC.

| | | | | |
|----------|-------|--------------|----------|-------|
| DESIGNER | SIZE | DATE: | PART NO. | REV |
| | A | 5/19/04 | FL-212NM | |
| APPROVED | SCALE | RELEASE DATE | WEIGHT | SHEET |
| | | | | |

| REVISIONS | | |
|-----------|-----|-------------|
| ZONE | REV | FINISHES: |
| | | BP, SL & WH |
| | | GAUGE: |
| | | 13ga. .090 |

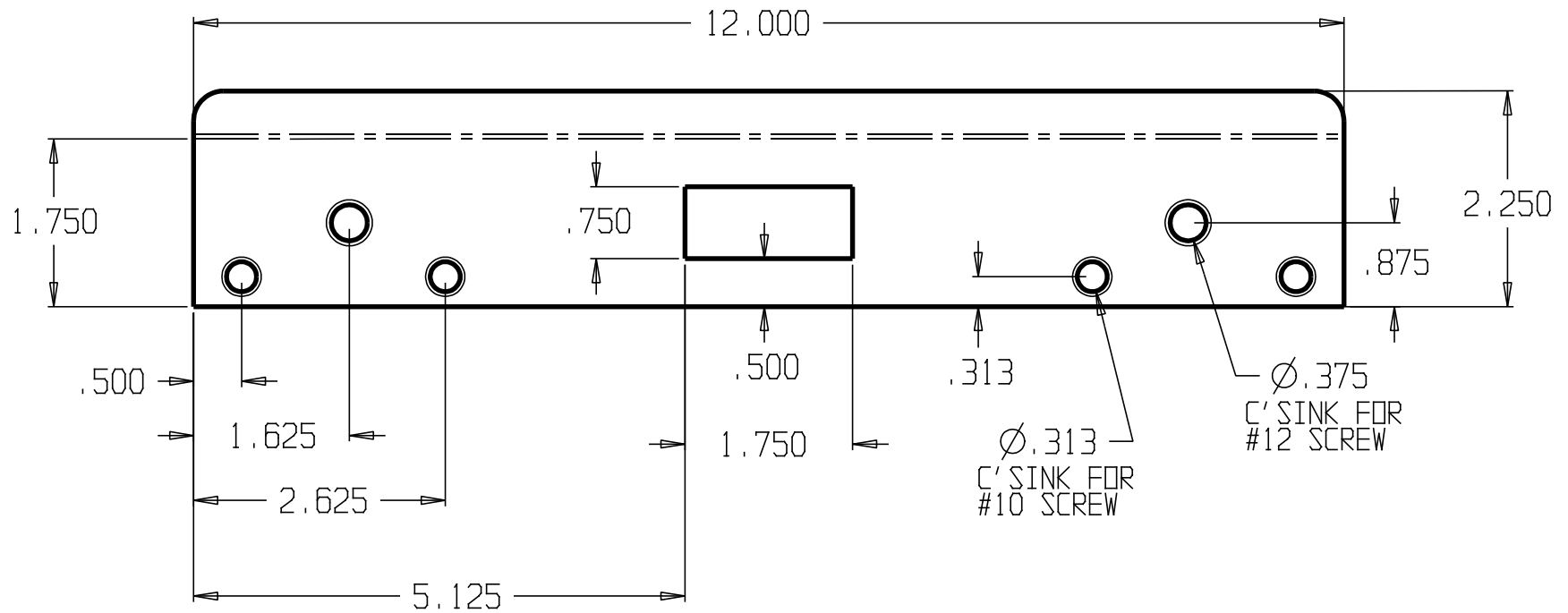

DON-JO MFG. INC.

| | | | | |
|----------|-------|--------------|----------|-------|
| DESIGNER | SIZE | DATE: | PART NO. | REV |
| | A | 5/19/04 | FL-212W | |
| APPROVED | SCALE | RELEASE DATE | WEIGHT | SHEET |
| | | | | |

| REVISIONS | | | |
|-----------|-----|-------------|------------|
| ZONE | REV | FINISHES: | GAUGE: |
| | | BP, SL & WH | 13ga. .090 |

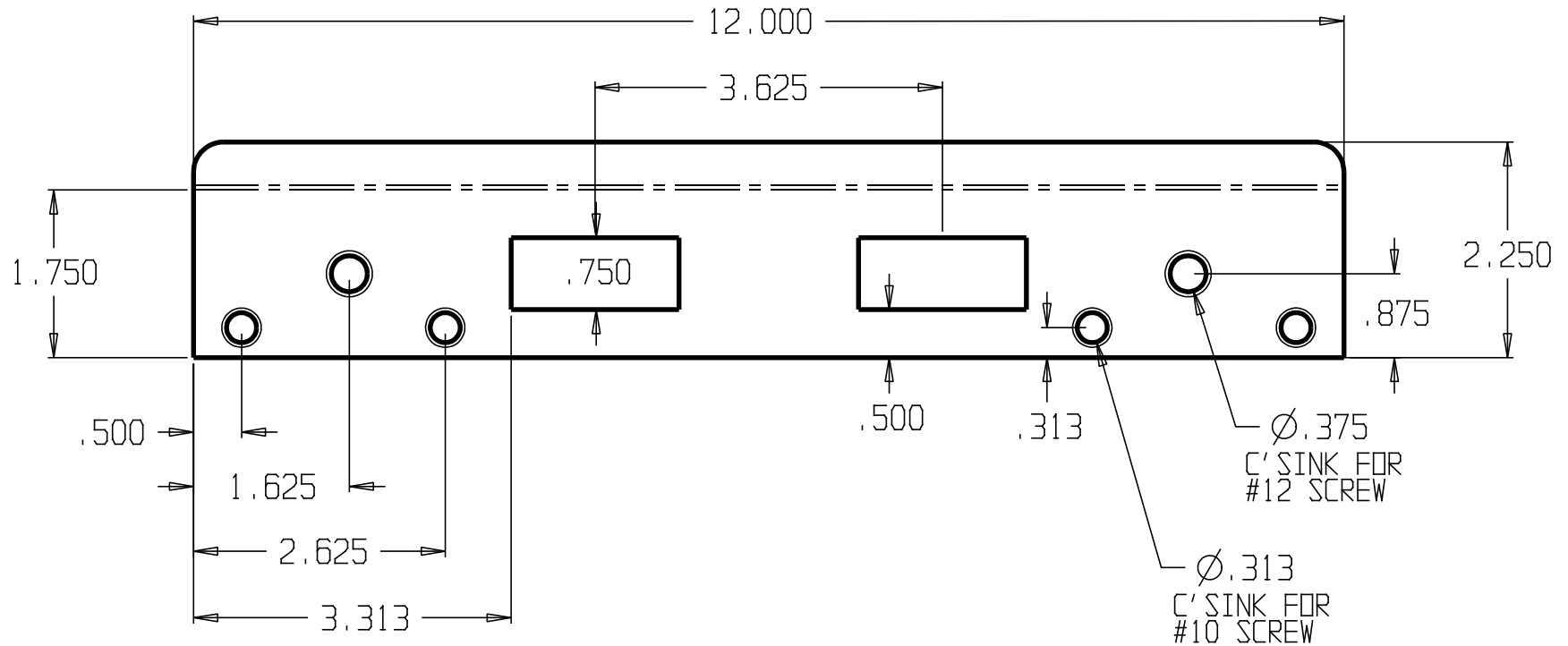

DON-JO MFG. INC.

| | | | | |
|----------|-------|--------------|----------|-------|
| DESIGNER | SIZE | DATE: | PART NO. | REV |
| | A | 5/19/04 | FL-212W4 | |
| APPROVED | SCALE | RELEASE DATE | WEIGHT | SHEET |

| REVISIONS | | | |
|-----------|-----|-----------|------------|
| ZONE | REV | FINISHES: | GAUGE: |
| | | BP | 13ga. .090 |

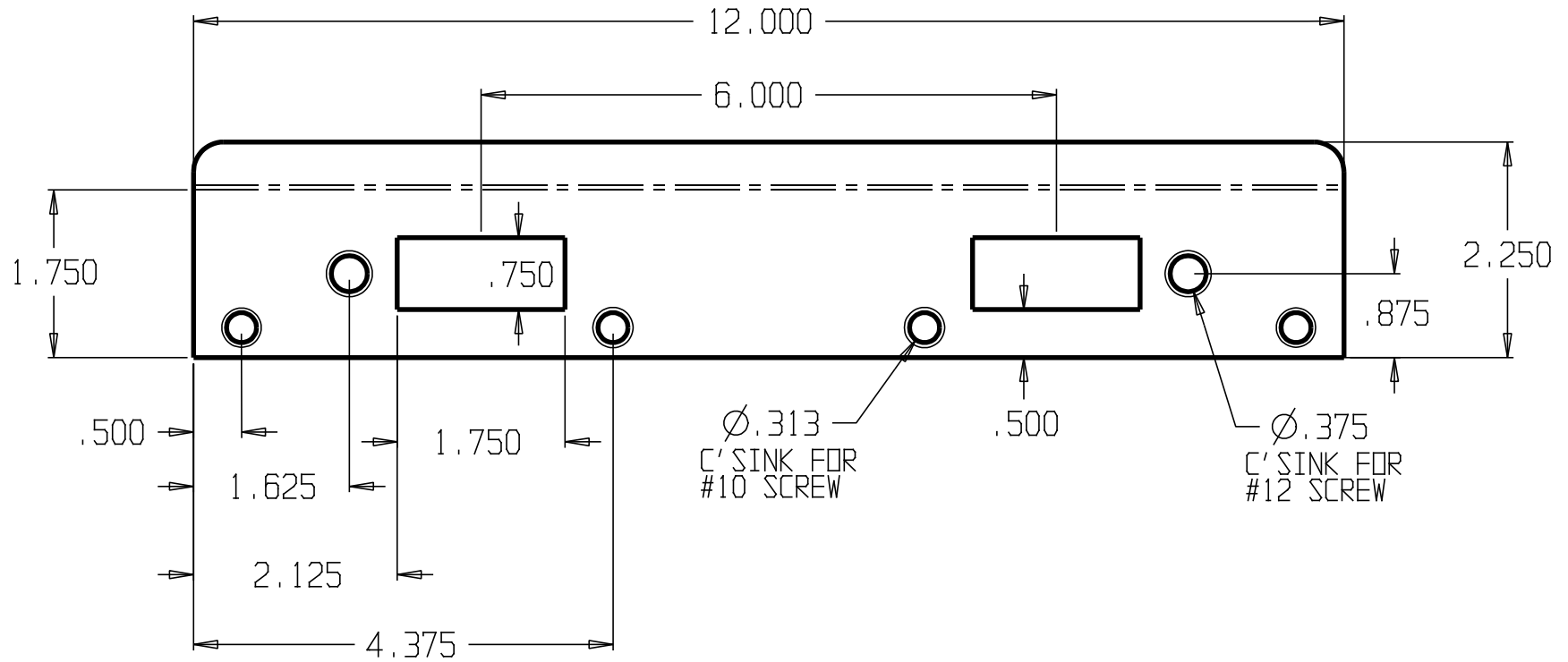

DON-JO MFG. INC.

| | | | | |
|----------|-------|--------------|----------|-------|
| DESIGNER | SIZE | DATE: | PART NO. | REV |
| | A | 5/19/04 | FL-212W6 | |
| APPROVED | SCALE | RELEASE DATE | WEIGHT | SHEET |
| | | | | |

| REVISIONS | | | |
|-----------|-----|-----------|------------|
| ZONE | REV | FINISHES: | GALUGE: |
| | | 630 | 13ga. .090 |

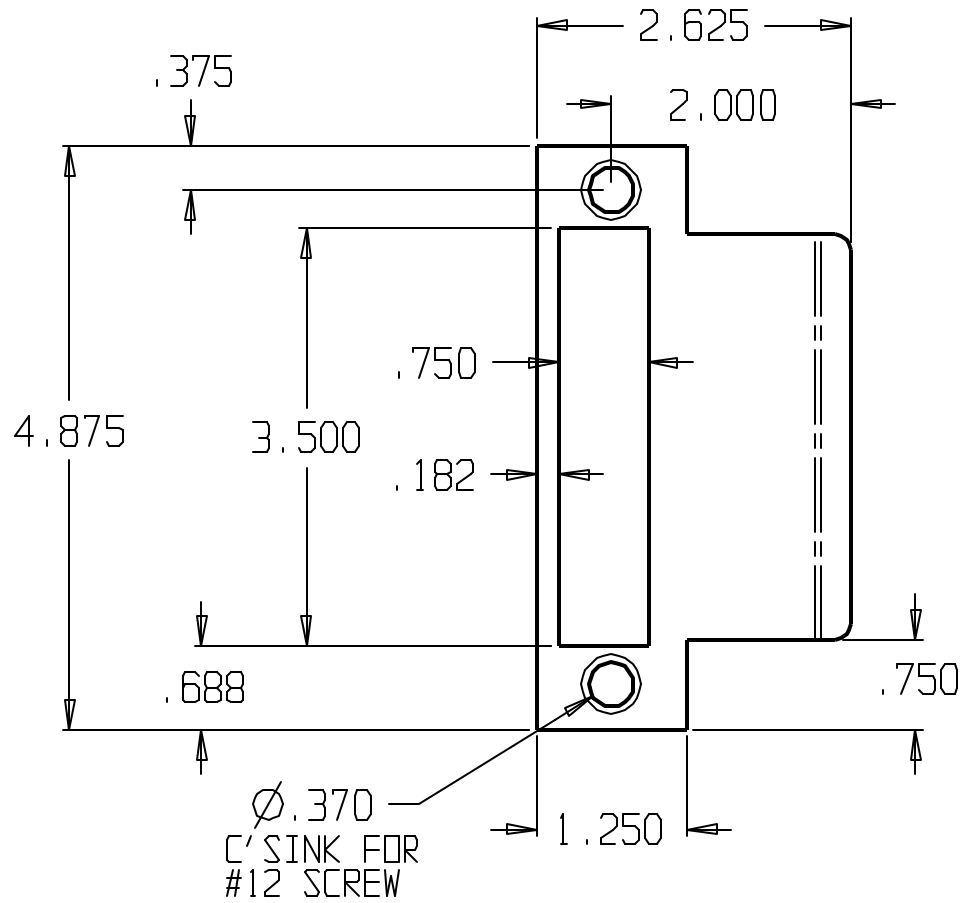

| | | | | | |
|------------------|--|-------|--------------|----------|-------|
| DON-JO MFG. INC. | | SIZE | DATE: | PART NO. | REV |
| DESIGNER | | A | 6/3/04 | MEST-102 | |
| APPROVED | | SCALE | RELEASE DATE | WEIGHT | SHEET |

| REVISIONS | | | |
|-----------|-----|-----------|------------|
| ZONE | REV | FINISHES: | GALUGE: |
| | | 630 | 13ga. .090 |

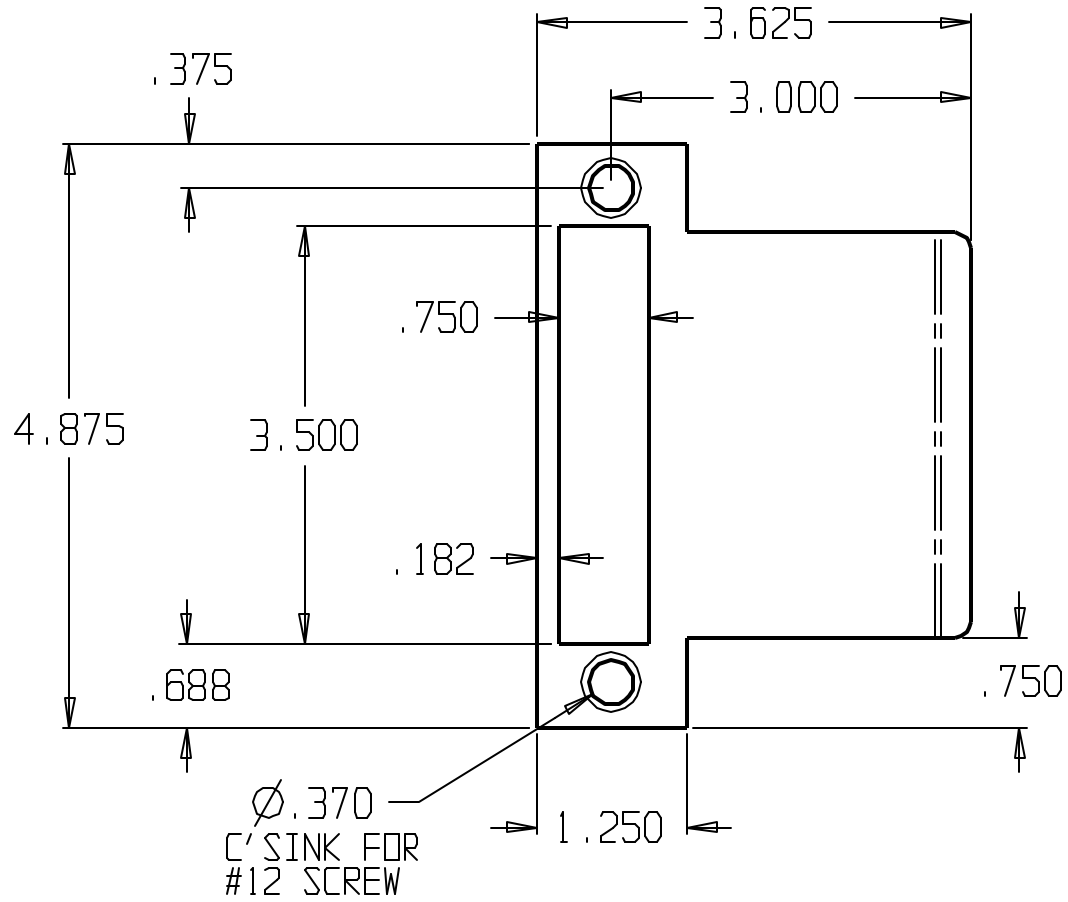

DON-JO MFG. INC.

| | |
|----------|--|
| DESIGNER | |
| APPROVED | |

| | | | |
|-----------|-----------------|----------------------|-------|
| SIZE A | DATE: 6/3/04 | PART NO. MEST-103 | REV |
| SCALE | RELEASE DATE | WEIGHT | SHEET |

| REVISIONS | | | |
|-----------|-----|-----------|------------|
| ZONE | REV | FINISHES: | GALUGE: |
| | | 630, DU | 13ga. .090 |

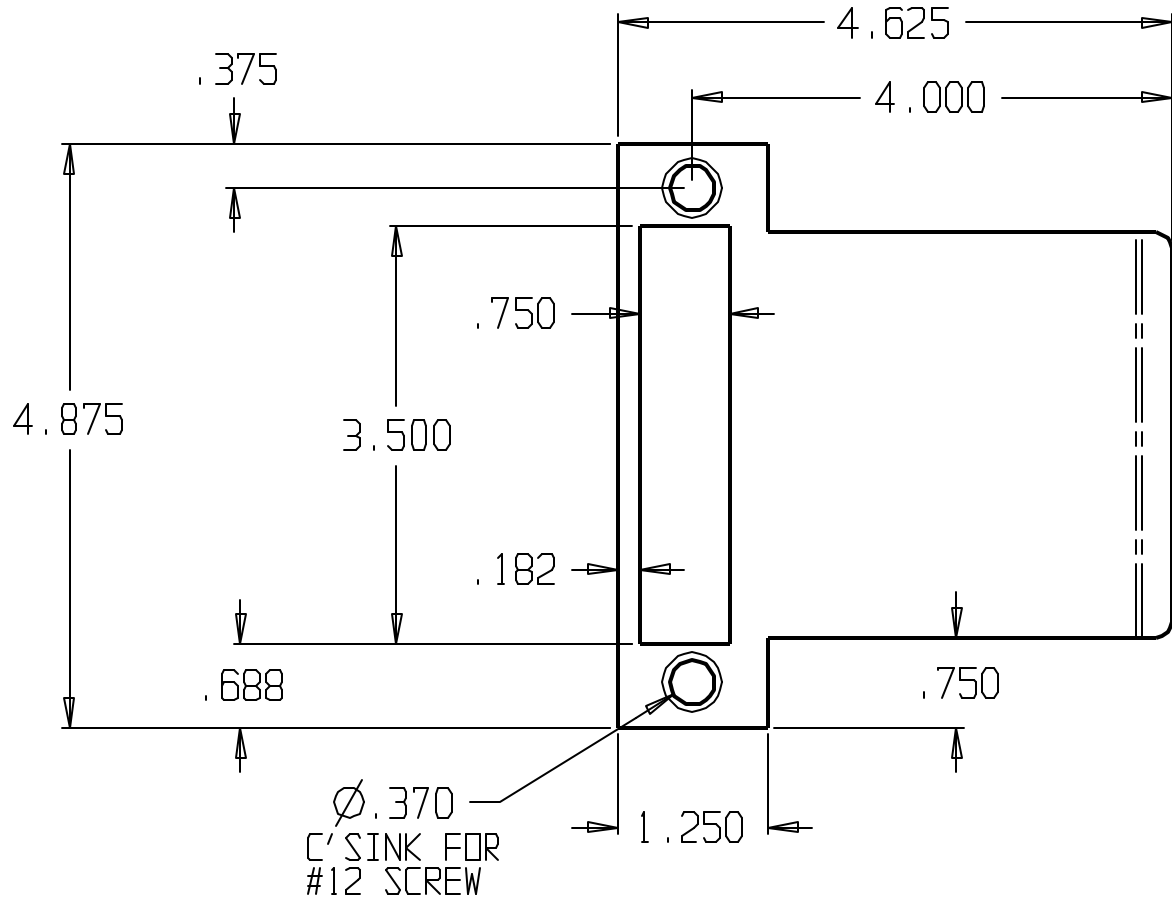

DON-JO MFG. INC.

| | | | | |
|----------|-----------|-----------------|----------------------|-------|
| DESIGNER | SIZE A | DATE: 6/3/04 | PART NO. MEST-104 | REV |
| APPROVED | SCALE | RELEASE DATE | WEIGHT | SHEET |

| REVISIONS | | | |
|-----------|-----|-----------|------------|
| ZONE | REV | FINISHES: | GALUGE: |
| | | 630 | 13ga. .090 |

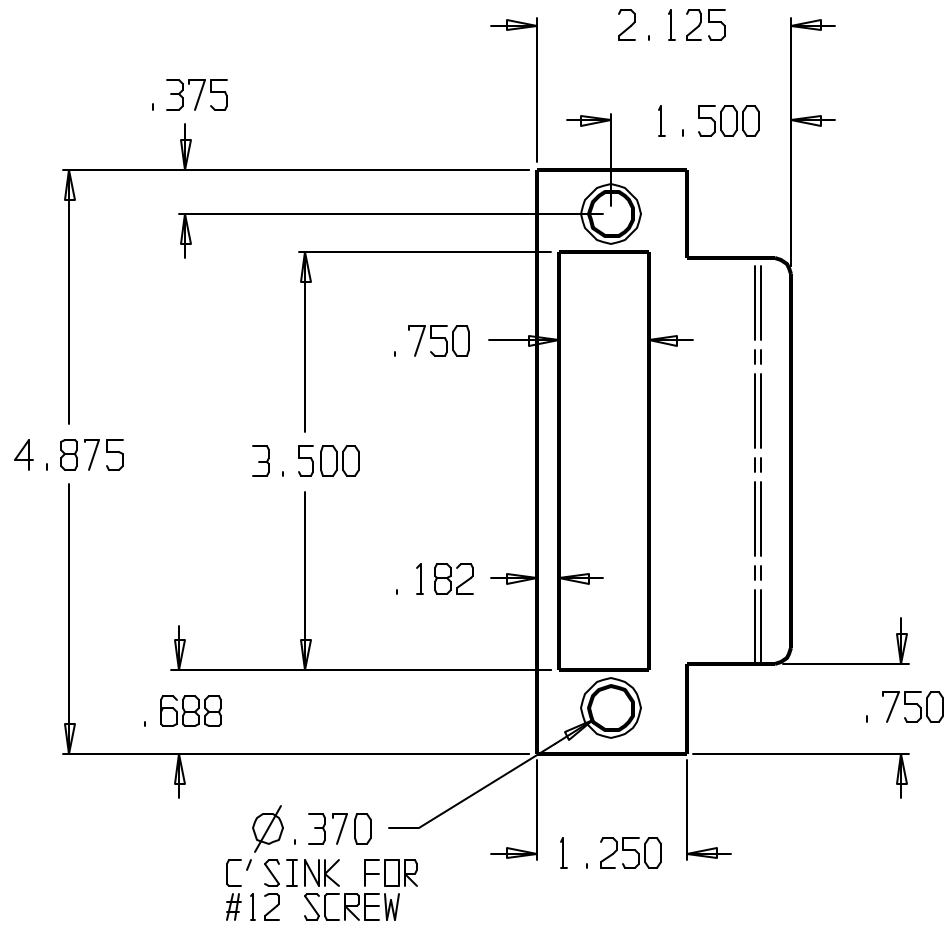

DON-JO MFG. INC.

| | | | | |
|----------|-----------|-----------------|----------------------|-------|
| DESIGNER | SIZE A | DATE: 6/3/04 | PART NO. MEST-115 | REV |
| APPROVED | SCALE | RELEASE DATE | WEIGHT | SHEET |

| REVISIONS | | | |
|-----------|-----|-----------|------------|
| ZONE | REV | FINISHES: | GALUGE: |
| | | 630 | 13ga. .090 |

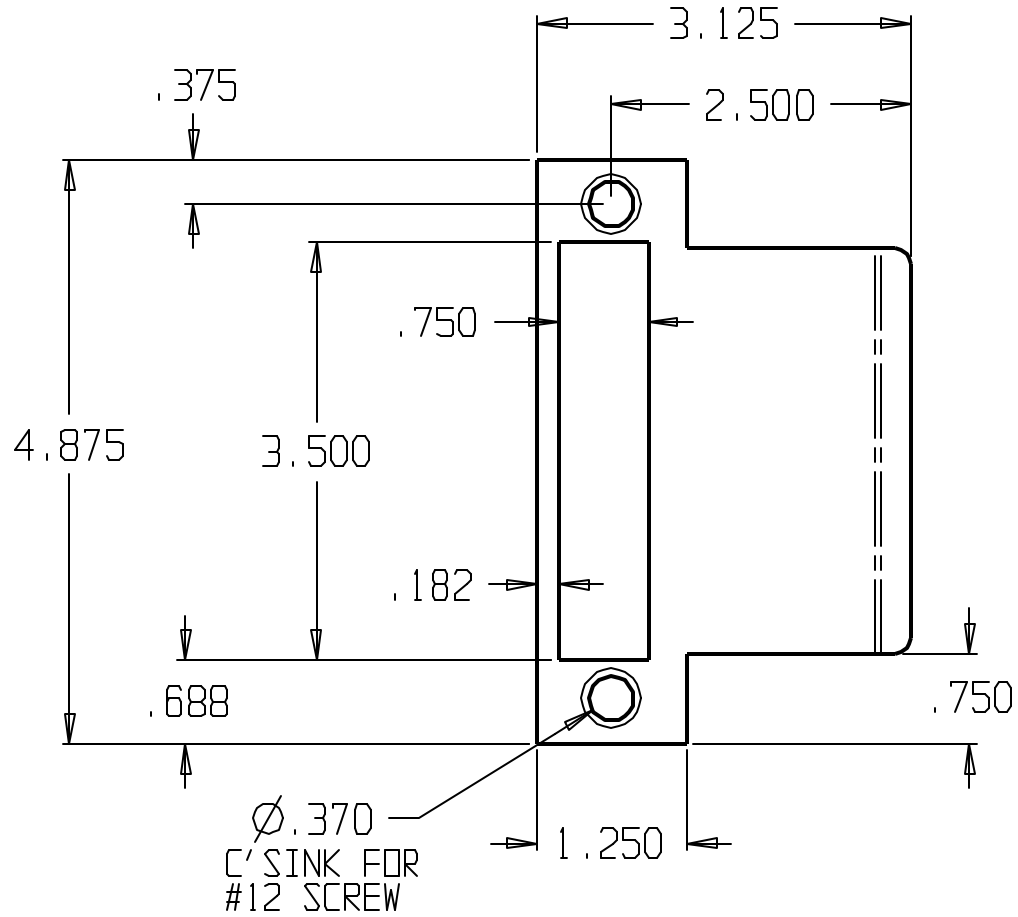

DON-JO MFG. INC.

| | | | | |
|----------|--------|--------------|-------------------|-------|
| DESIGNER | SIZE A | DATE: 6/3/04 | PART NO. MEST-125 | REV |
| APPROVED | SCALE | RELEASE DATE | WEIGHT | SHEET |

| REVISIONS | | | |
|-----------|-----|-----------|------------|
| ZONE | REV | FINISHES: | GALUGE: |
| | | 630 | 13ga. .090 |

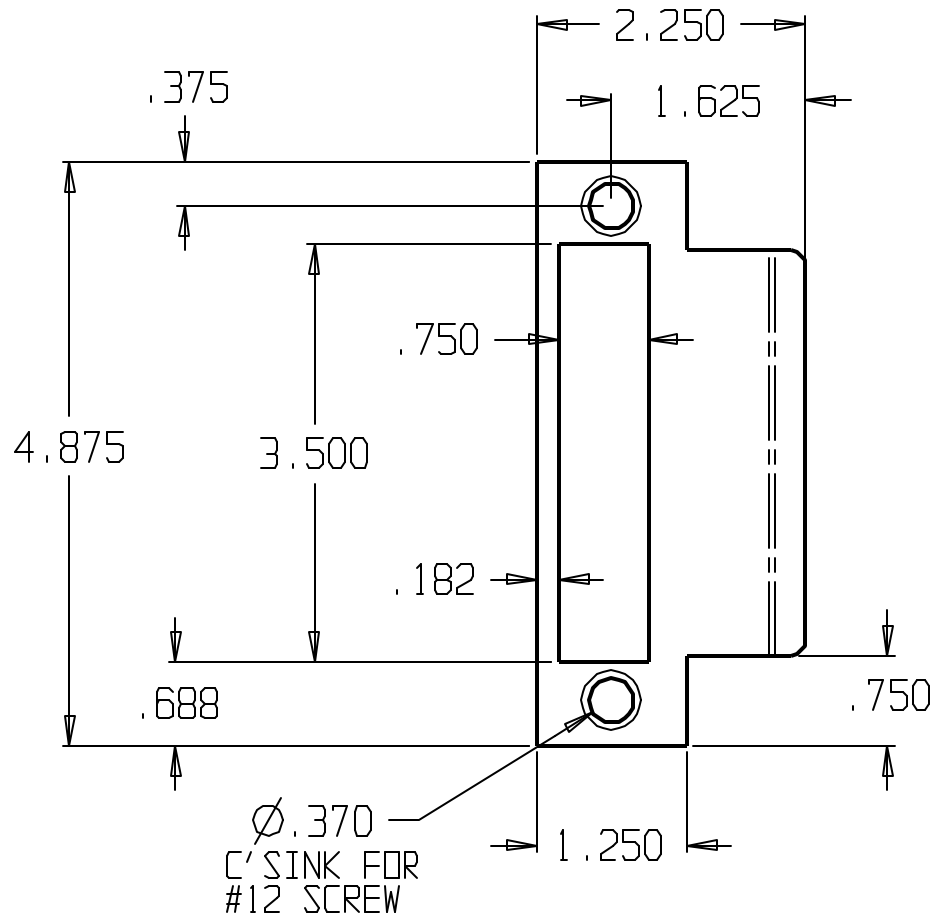

| | | | | | |
|------------------|--|-------|--------------|----------|-------|
| DON-JO MFG. INC. | | SIZE | DATE: | PART NO. | REV |
| DESIGNER | | A | 6/3/04 | MEST-158 | |
| APPROVED | | SCALE | RELEASE DATE | WEIGHT | SHEET |

| REVISIONS | | | |
|-----------|-----|-----------|------------|
| ZONE | REV | FINISHES: | GALUGE: |
| | | 630 | 13ga. .090 |

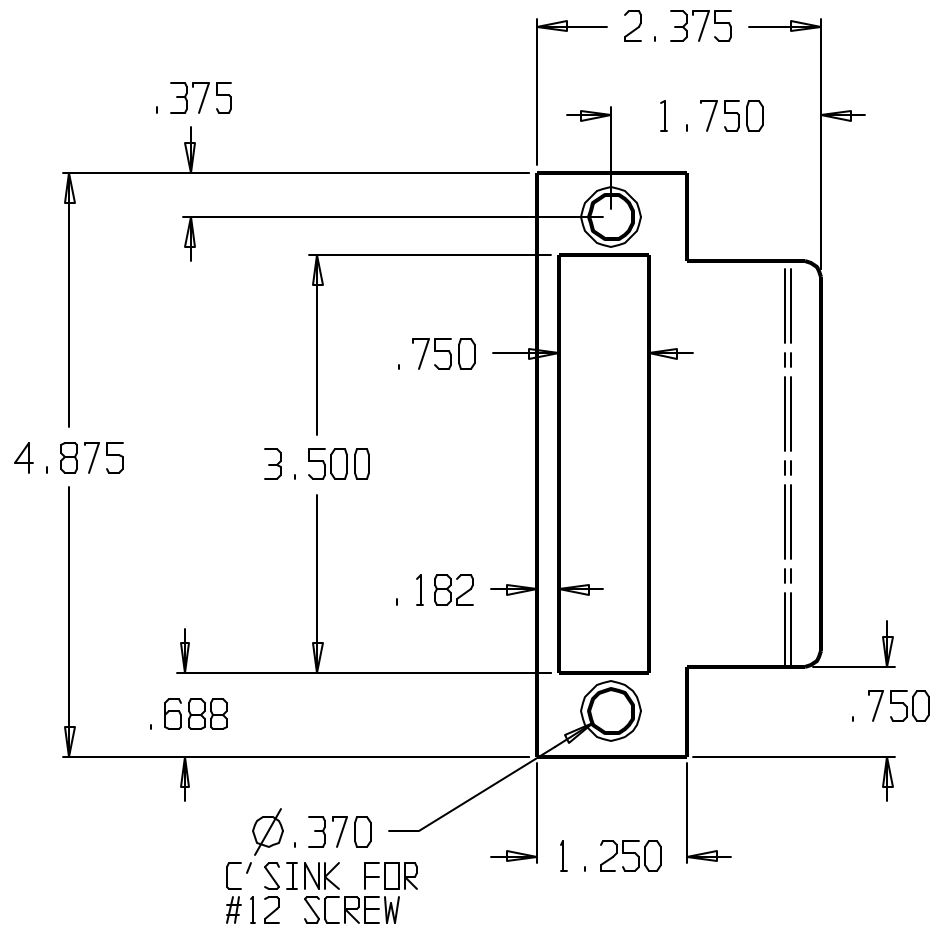

DON-JO MFG. INC.

| | |
|----------|--|
| DESIGNER | |
| APPROVED | |

| | | | |
|-------|--------------|----------|-------|
| SIZE | DATE: | PART NO. | REV |
| A | 6/3/04 | MEST-175 | |
| SCALE | RELEASE DATE | WEIGHT | SHEET |

REVISIONS

| | | | |
|------|-----|-----------|------------|
| ZONE | REV | FINISHES: | GUAGE: |
| | | 630 | 13ga. .090 |

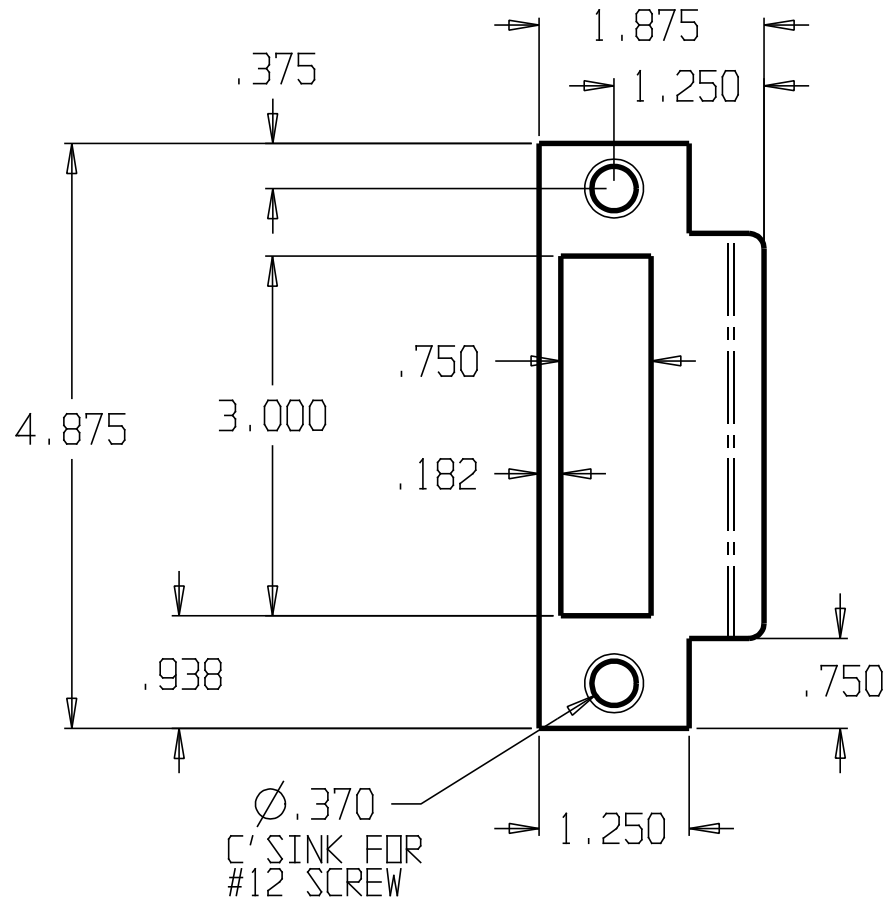

DON-JO MFG. INC.

| | | | | |
|----------|-----------|-----------------|---------------------|-------|
| DESIGNER | SIZE A | DATE: 6/3/04 | PART NO. MST-161 | REV |
| APPROVED | SCALE | RELEASE DATE | WEIGHT | SHEET |

REVISIONS

| | | | |
|------|-----|-----------------------|-------------------|
| ZONE | REV | FINISHES: BP, DU & SL | GUAGE: 13ga. .090 |
|------|-----|-----------------------|-------------------|

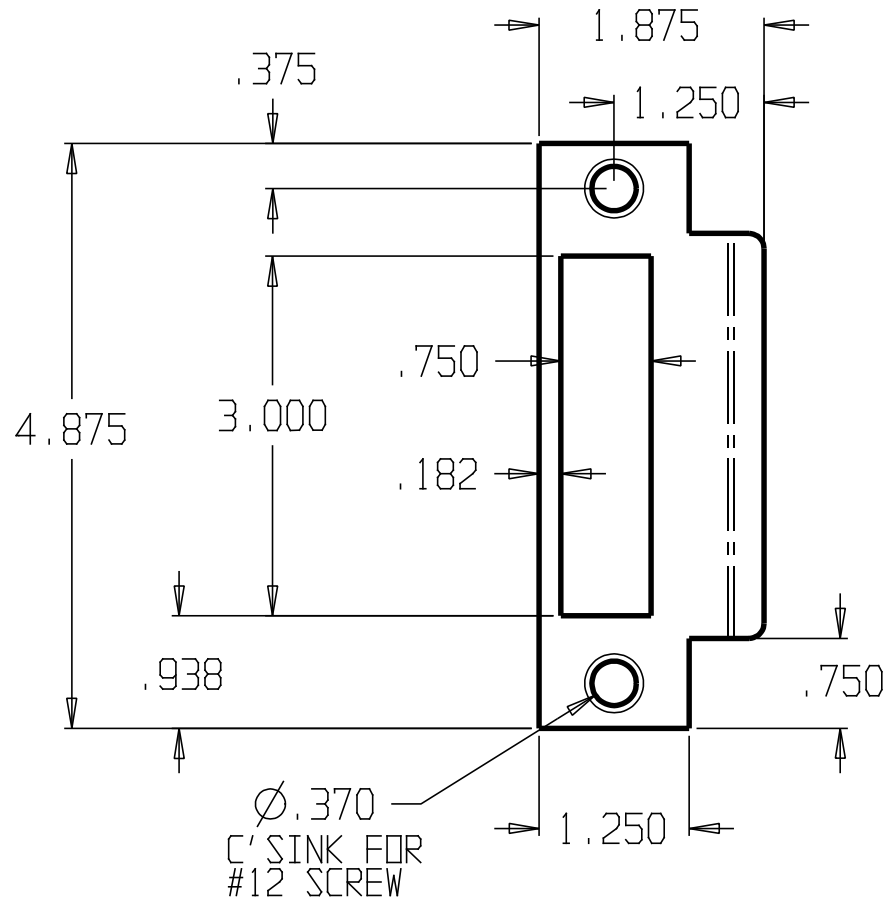

DON-JO MFG. INC.

| | | | | |
|----------|--------|--------------|------------------|-------|
| DESIGNER | SIZE A | DATE: 6/3/04 | PART NO. MST-261 | REV |
| APPROVED | SCALE | RELEASE DATE | WEIGHT | SHEET |

| REVISIONS | | | |
|-----------|-----|-----------|-----------|
| ZONE | REV | FINISHES: | GALIGE: |
| | | 630 | 13ga .090 |

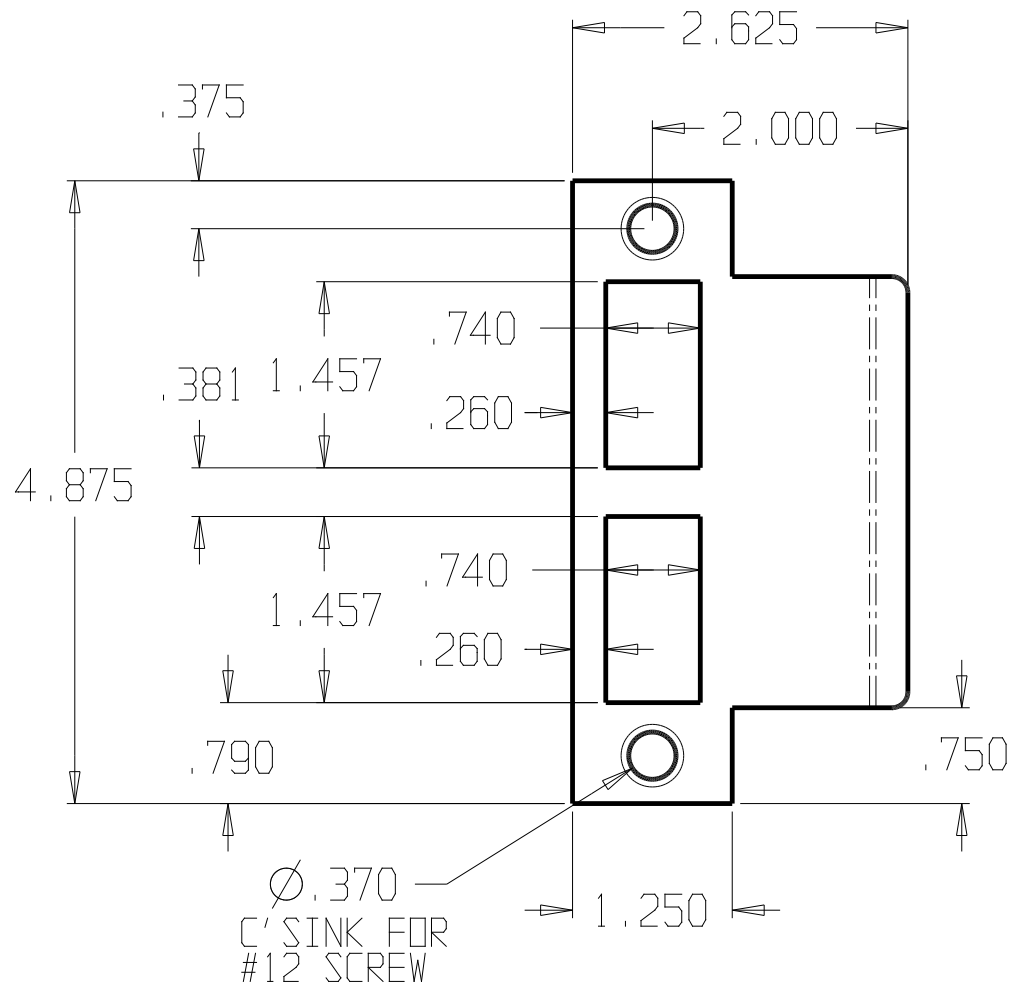

| | | | | | |
|-------------------------|--|-------|--------------|------------------|-------|
| DON-JO MFG. INC. | | SIZE | DATE: | PART NO. | REV |
| | | A | 2/11/15 | SMEST-102 | |
| DESIGNER | | SCALE | RELEASE DATE | WEIGHT | SHEET |
| APPROVED | | | | | |

DWG NO

SH

REV

REVISIONS

ZONE

REV

FINISHES:

630

GALIGE:

13ga .090

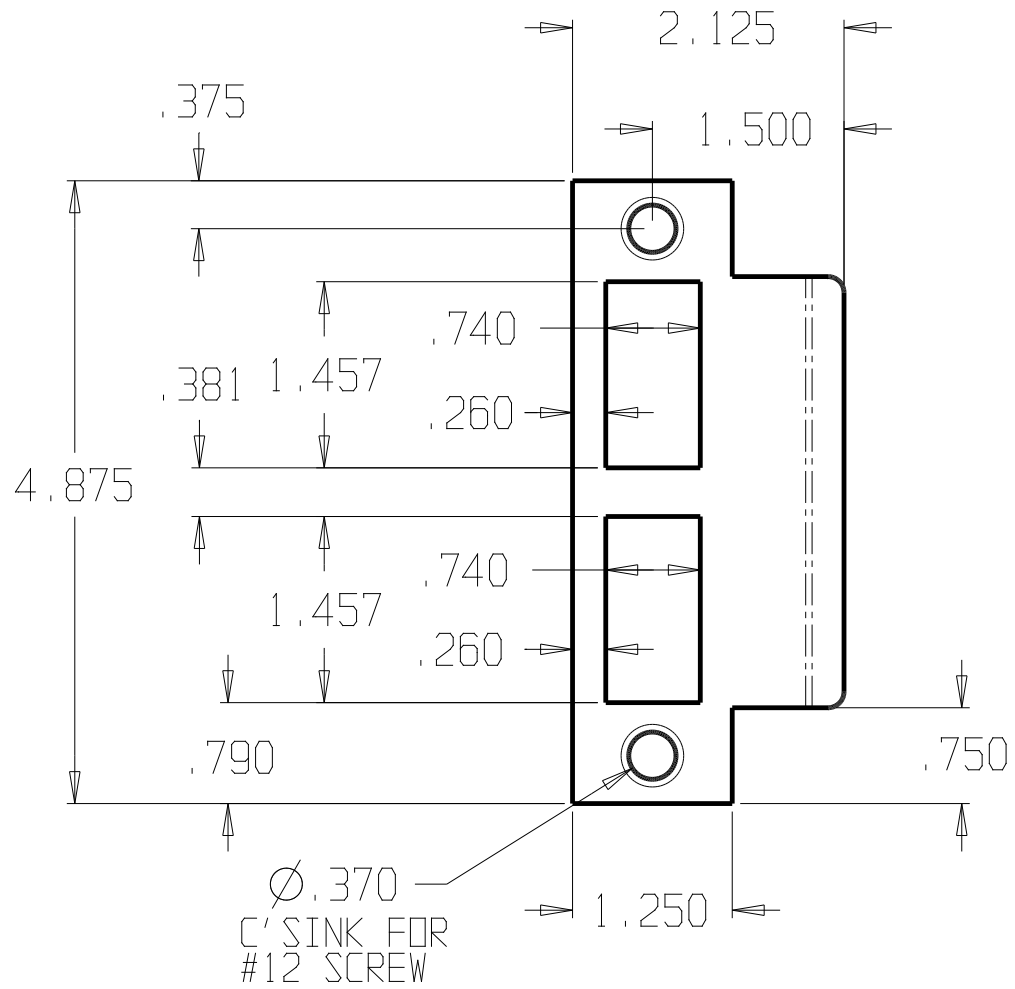

DON-JO MFG. INC.

DESIGNER

APPROVED

SIZE
A

DATE:
2/11/15

PART NO.
SMEST-115

REV

SCALE

RELEASE DATE

WEIGHT

SHEET

| REVISIONS | | | |
|-----------|-----|-----------|-----------|
| ZONE | REV | FINISHES: | GALIGE: |
| | | 630 | 13ga .090 |

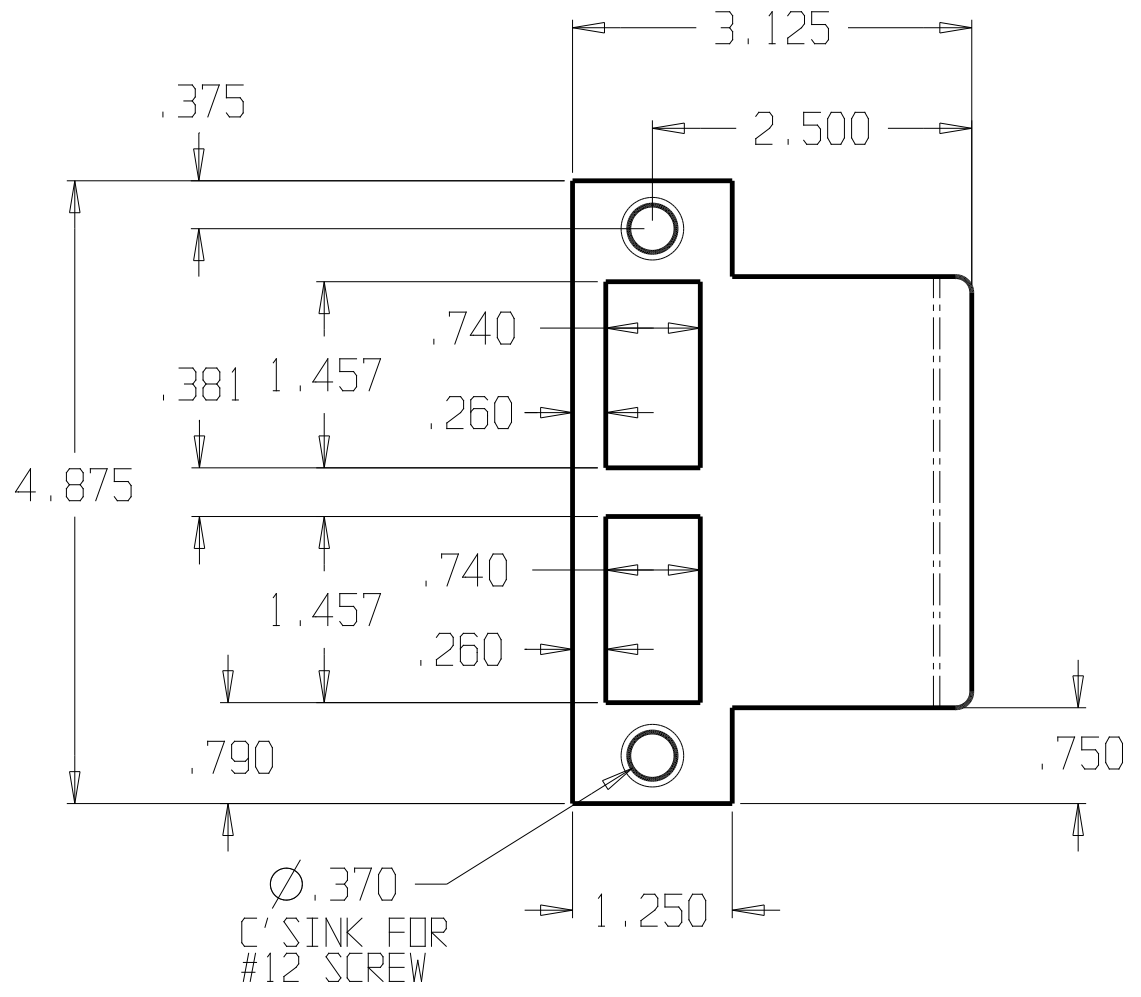

| | | | | | |
|-------------------------|--|-------|--------------|------------------|-------|
| DON-JO MFG. INC. | | SIZE | DATE: | PART NO. | REV |
| | | A | 2/11/15 | SMEST-125 | |
| DESIGNER | | SCALE | RELEASE DATE | WEIGHT | SHEET |
| APPROVED | | | | | |

| REVISIONS | | | |
|-----------|-----|-----------|-----------|
| ZONE | REV | FINISHES: | GALIGE: |
| | | 630 | 13ga .090 |

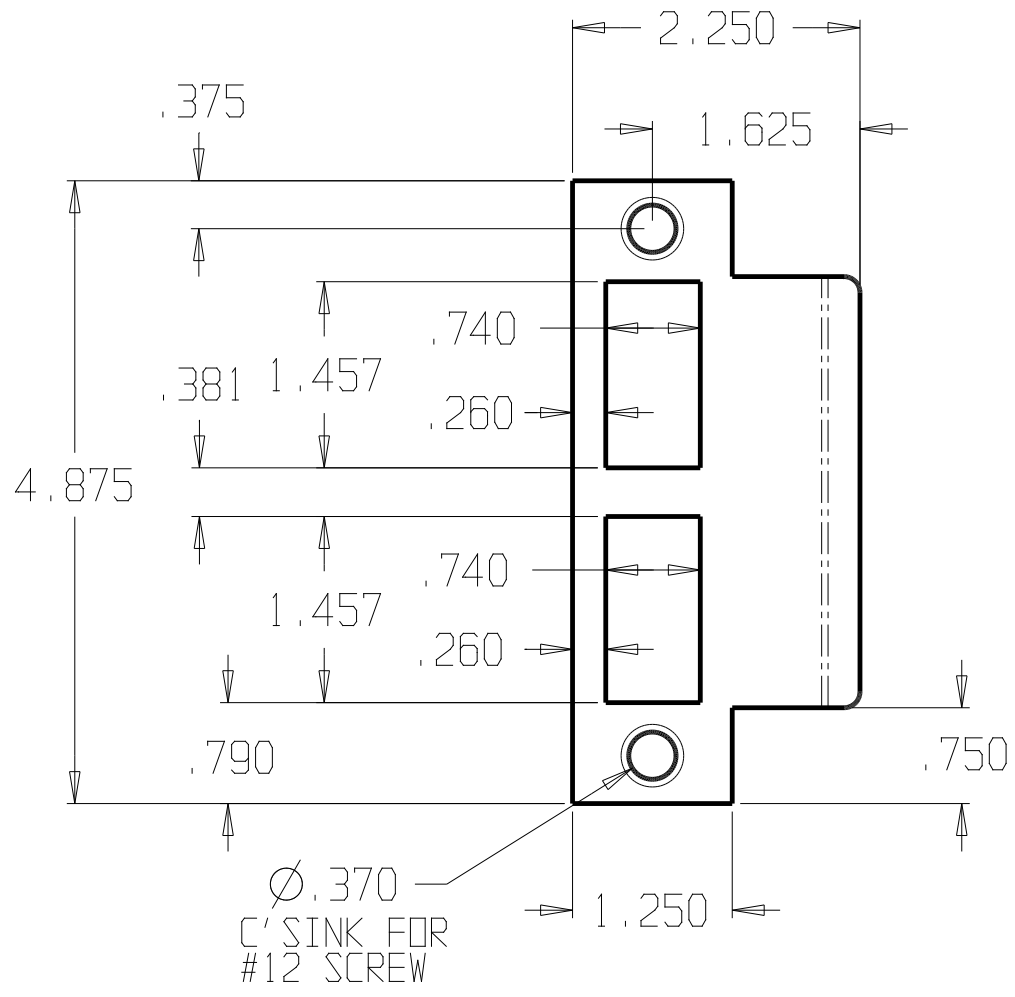

| | | | | | |
|-------------------------|--|-------|--------------|------------------|-------|
| DON-JO MFG. INC. | | SIZE | DATE: | PART NO. | REV |
| | | A | 2/11/15 | SMEST-158 | |
| DESIGNER | | SCALE | RELEASE DATE | WEIGHT | SHEET |
| APPROVED | | | | | |

| REVISIONS | | | |
|-----------|-----|-----------|------------|
| ZONE | REV | FINISHES: | GALUGE: |
| | | 630 | 13ga. .090 |

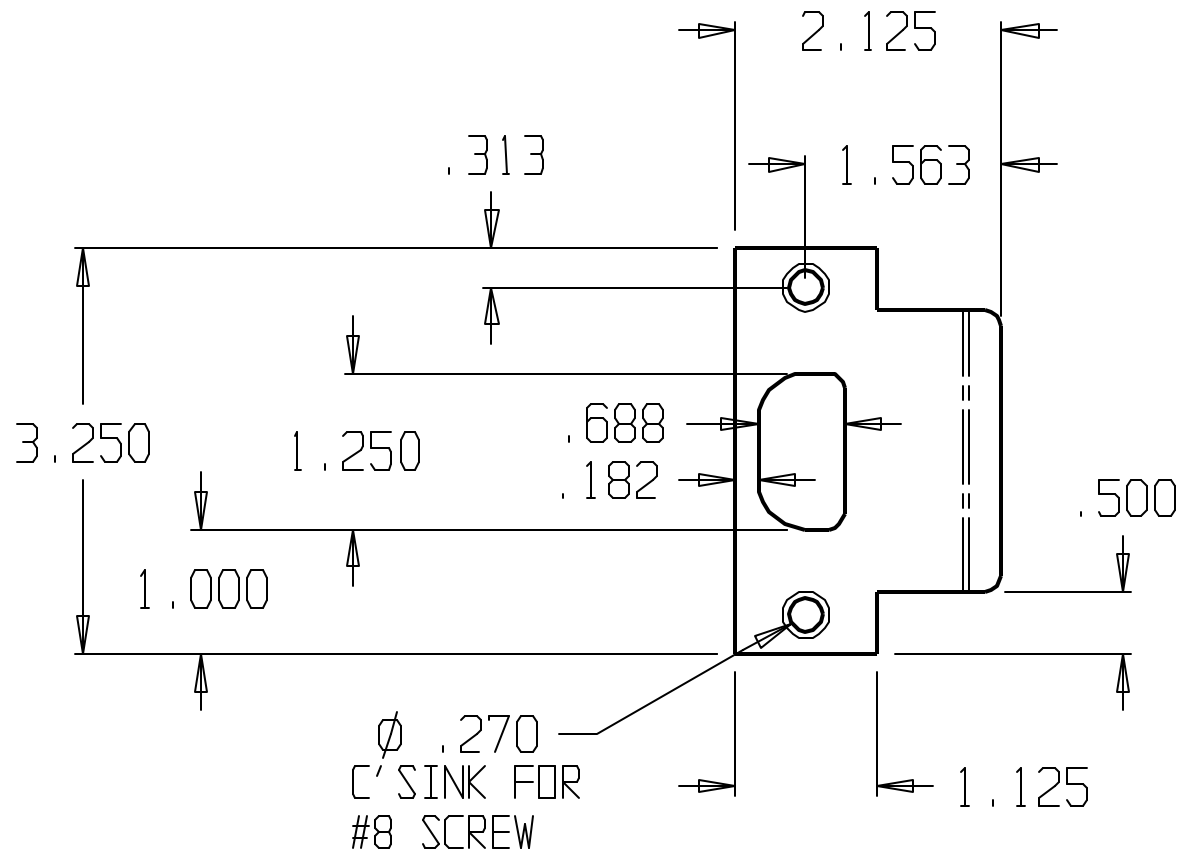

DON-JO MFG. INC.

DESIGNER

APPROVED

| | | | |
|-----------|-----------------|--------------------|-------|
| SIZE A | DATE: 6/3/04 | PART NO. ST-134 | REV |
| SCALE | RELEASE DATE | WEIGHT | SHEET |

| REVISIONS | | | |
|-----------|-----|-----------|------------|
| ZONE | REV | FINISHES: | GAUGE: |
| | | 630 | 14ga. .075 |

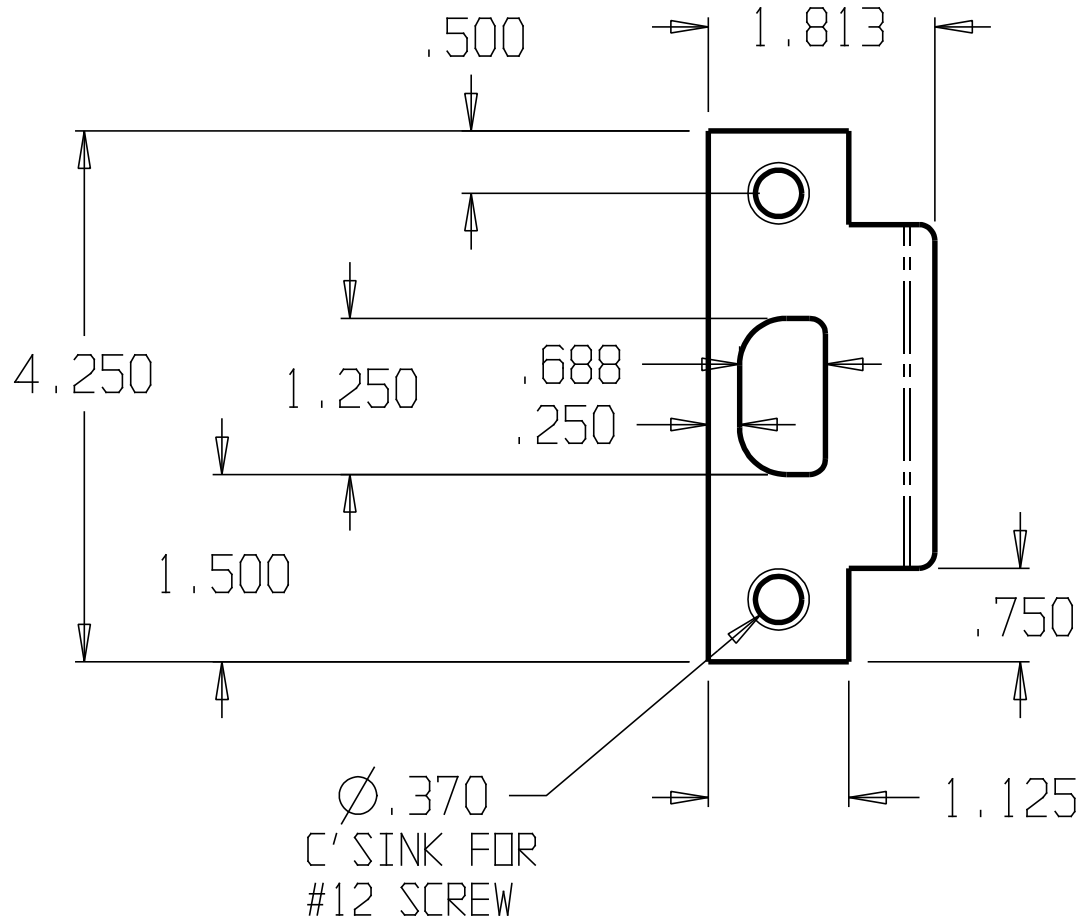

DON-JO MFG. INC.

DESIGNER
APPROVED

SIZE: A
DATE: 6/3/04
SCALE

PART NO. ST-144
REVISIONS
RELEASE DATE
WEIGHT
SHEET

| REVISIONS | | | |
|-----------|-----|---------------------------------|------------|
| ZONE | REV | FINISHES: | GUAGE: |
| | | 605,606,612,613, 625,626,630 | 13ga. .090 |

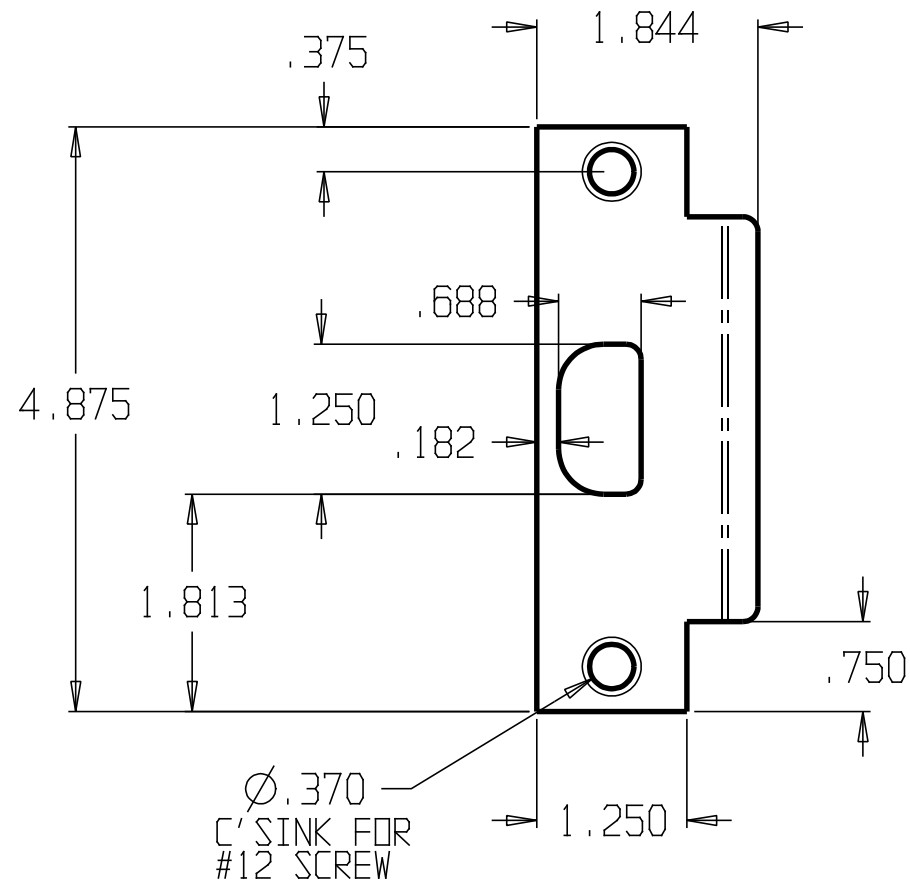

DON-JO MFG. INC.

| | | | | |
|----------|-----------|-----------------|--------------------|-------|
| DESIGNER | SIZE A | DATE: 6/3/04 | PART NO. ST-161 | REV |
| APPROVED | SCALE | RELEASE DATE | WEIGHT | SHEET |

| REVISIONS | | | | |
|-----------|-----|------------------------|------|----------|
| ZONE | REV | MATERIAL : | DATE | APPROVED |
| | | 605, 619, 620, 630, DU | | |

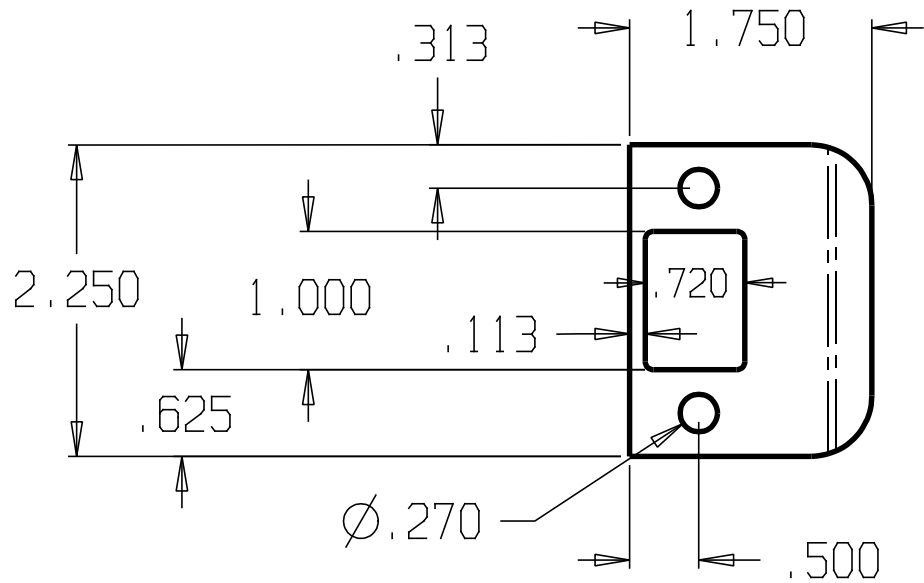

DON-JO MFG. INC.

| | |
|----------|--|
| DESIGNER | |
| APPROVED | |

| | | | |
|-----------|------------------|--------------------|-------|
| SIZE A | DATE: 3/25/04 | PART NO. ST-214 | REV |
| SCALE | RELEASE DATE | WEIGHT | SHEET |

| | | |
|--------|----|-----|
| DWG NO | SH | REV |
|--------|----|-----|

| REVISIONS | | | | |
|-----------|-----|--------------------|------|----------|
| ZONE | REV | MATERIAL : | DATE | APPROVED |
| | | 605,619,620,630,DU | | |

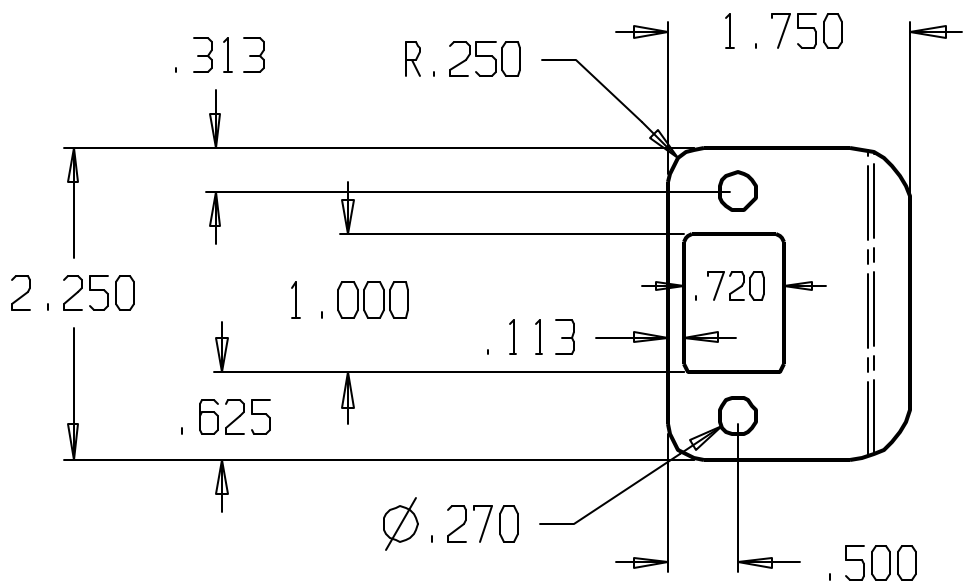

DON-JO MFG. INC.

| | | | | |
|----------|---------|---------------|--------------------|-------|
| DESIGNER | SIZE: A | DATE: 3/25/04 | PART NO. ST-214-RC | REV |
| APPROVED | SCALE | RELEASE DATE | WEIGHT | SHEET |

| REVISIONS | | | |
|-----------|-----|-------------|------------|
| ZONE | REV | FINISHES: | GUAGE: |
| | | BP, DU & SL | 13ga. .090 |

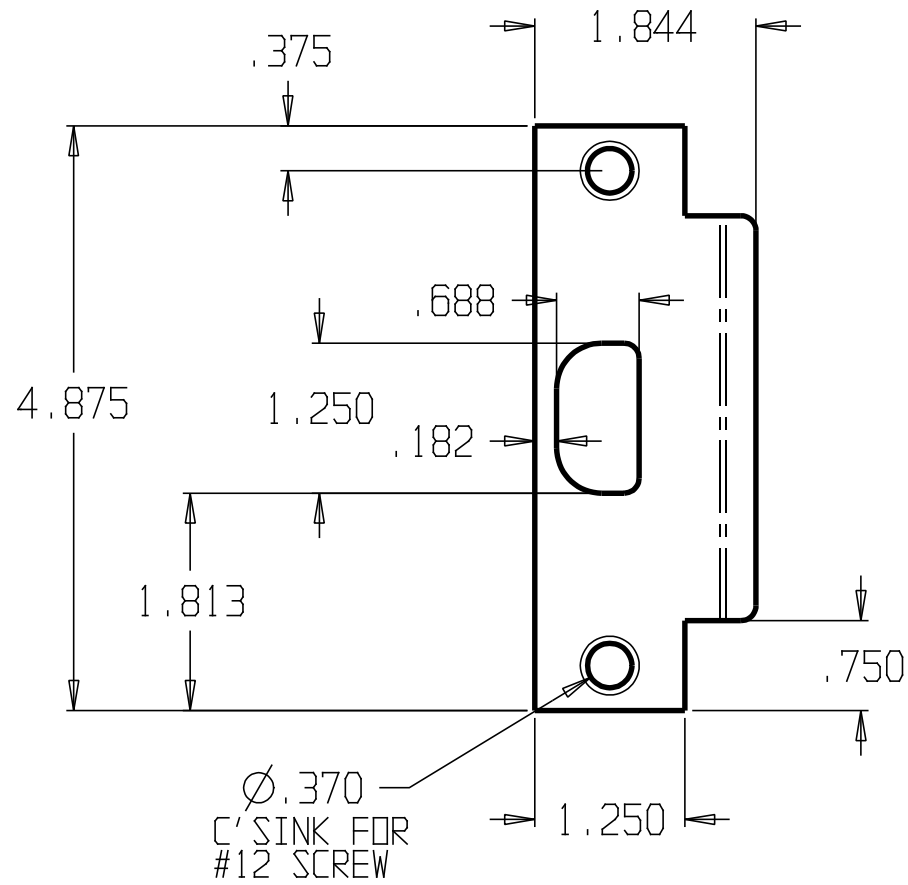

DON-JO MFG. INC.

| | | | | |
|----------|-------|--------------|----------|-------|
| DESIGNER | SIZE | DATE: | PART NO. | REV |
| | A | 6/3/04 | ST-261 | |
| APPROVED | SCALE | RELEASE DATE | WEIGHT | SHEET |
| | | | | |

| | | |
|---------|----|-----|
| DWG NO. | SH | REV |
|---------|----|-----|

| REVISIONS | | | |
|-----------|-----|------------|----------|
| ZONE | REV | FINISHES : | GALUGE : |
| | | | |

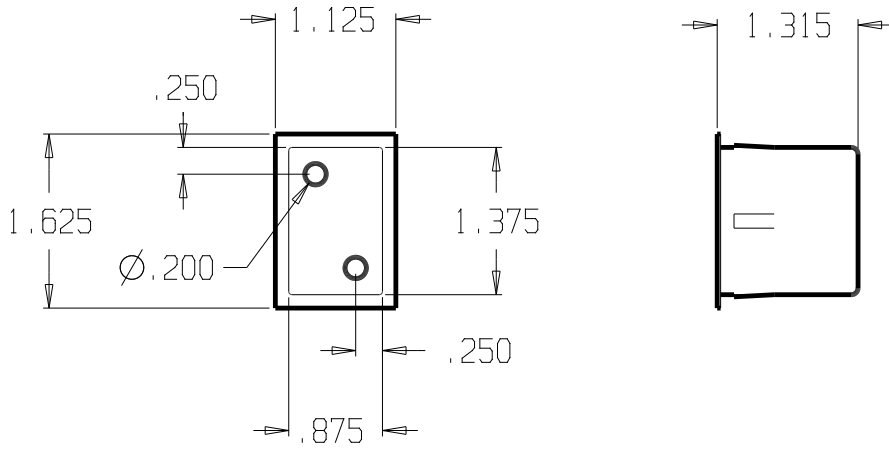

| | |
|-------------------------|------|
| DON-JO MFG. INC. | |
| DESIGNER | D.R. |

| | | | |
|-------|--------------|----------|-------|
| SIZE | DATE: | PART NO. | REV |
| A | 12/3/15 | TS-200 | |
| SCALE | RELEASE DATE | WEIGHT | SHEET |
| | | | |

| | | |
|---------|----|-----|
| DWG NO. | SH | REV |
|---------|----|-----|

| REVISIONS | | FINISHES: | GALUGE: |
|-----------|-----|-----------|------------|
| ZONE | REV | 605 & 630 | 18ga. .050 |

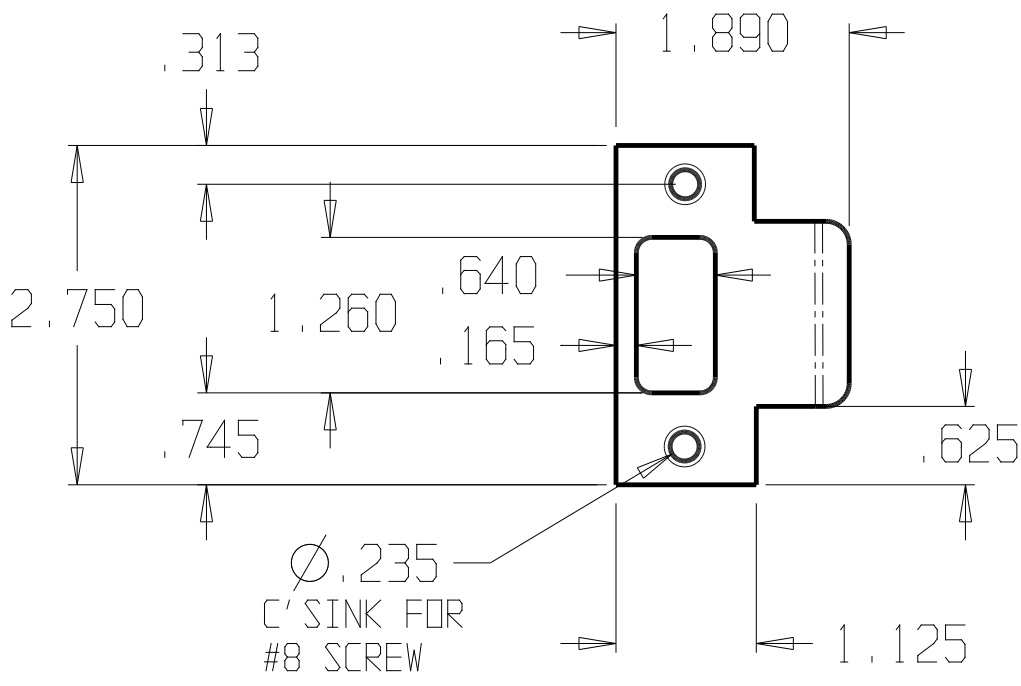

$\varnothing .235$
 C' SINK FOR
 #8 SCREW

DON-JO MFG. INC.

| | | | | |
|----------|-------|--------------|----------|-------|
| DESIGNER | SIZE | DATE: | PART NO. | REV |
| | A | 8/14/15 | TS-234 | |
| APPROVED | SCALE | RELEASE DATE | WEIGHT | SHEET |

| REVISIONS | | |
|-----------|-----|---------------------|
| ZONE | REV | FINISHES: |
| | | PB, AB, BZ, 10B & S |
| | | GALUGE: |
| | | 22ga. .032 |

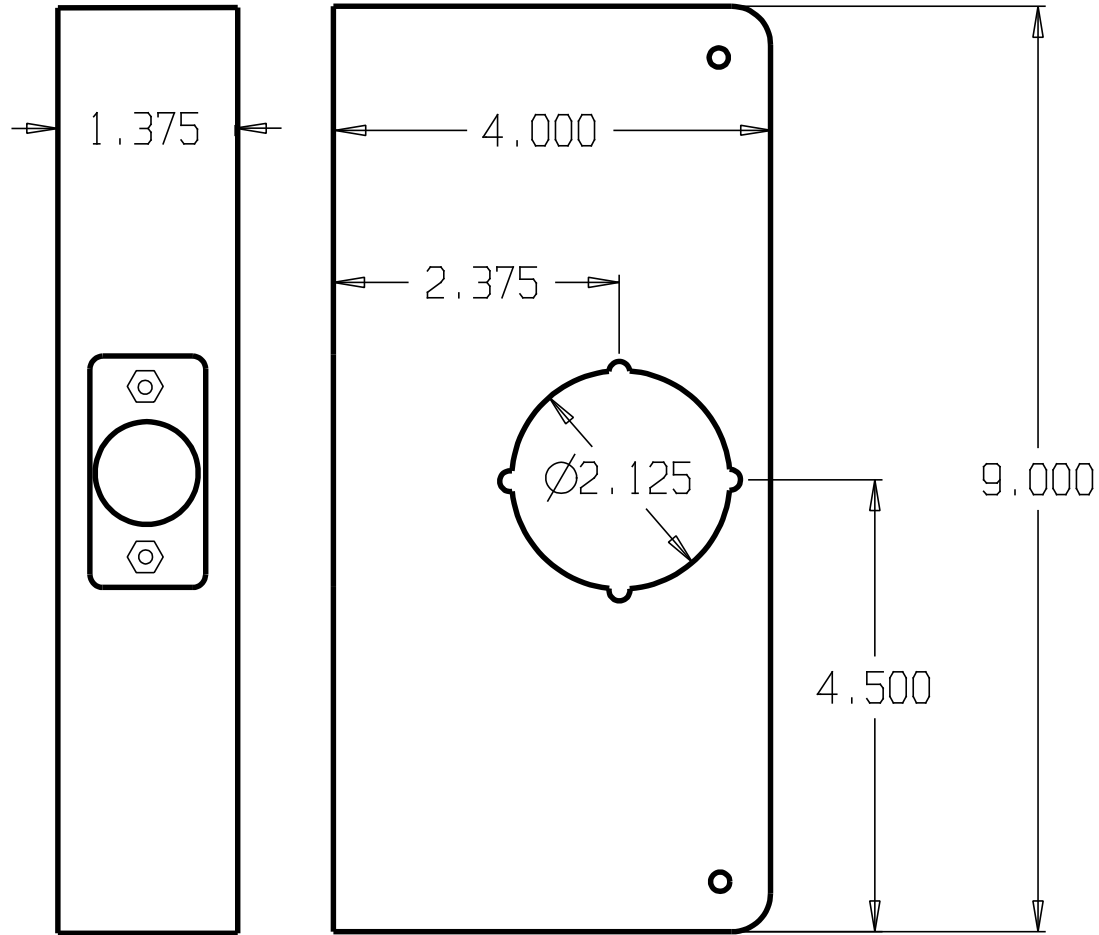

DON-JO MFG. INC.

DESIGNER
APPROVED

| | | | |
|-----------|-----------------|------------------|-------|
| SIZE A | DATE: 1/1/94 | PART NO. 1-CW | REV |
| SCALE | RELEASE DATE | WEIGHT | SHEET |

| REVISIONS | | | |
|-----------|-----|-------------|------|
| ZONE | REV | FINISHES: | DATE |
| | | 605-609-630 | |
| | | APPROVED | |

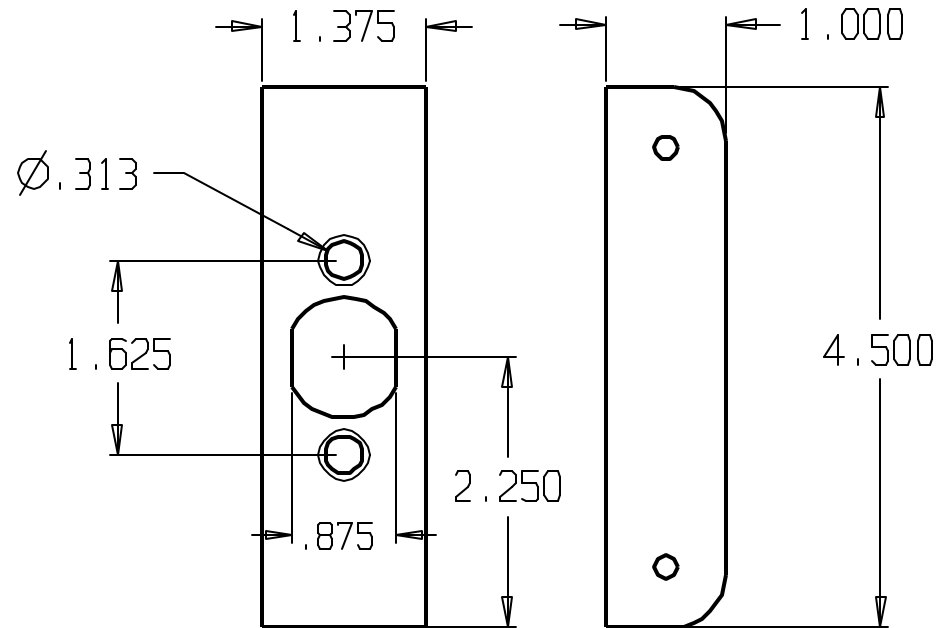

DON-JO MFG. INC.

| | | | | |
|----------|-------|--------------|----------|-------|
| DESIGNER | SIZE | DATE: | PART NO. | REV |
| | A | 2/10/04 | 10 FE | |
| APPROVED | SCALE | RELEASE DATE | WEIGHT | SHEET |

| REVISIONS | | | | |
|-----------|-----|-----------|------|----------|
| ZONE | REV | FINISHES: | DATE | APPROVED |
| | | PB & S | | |

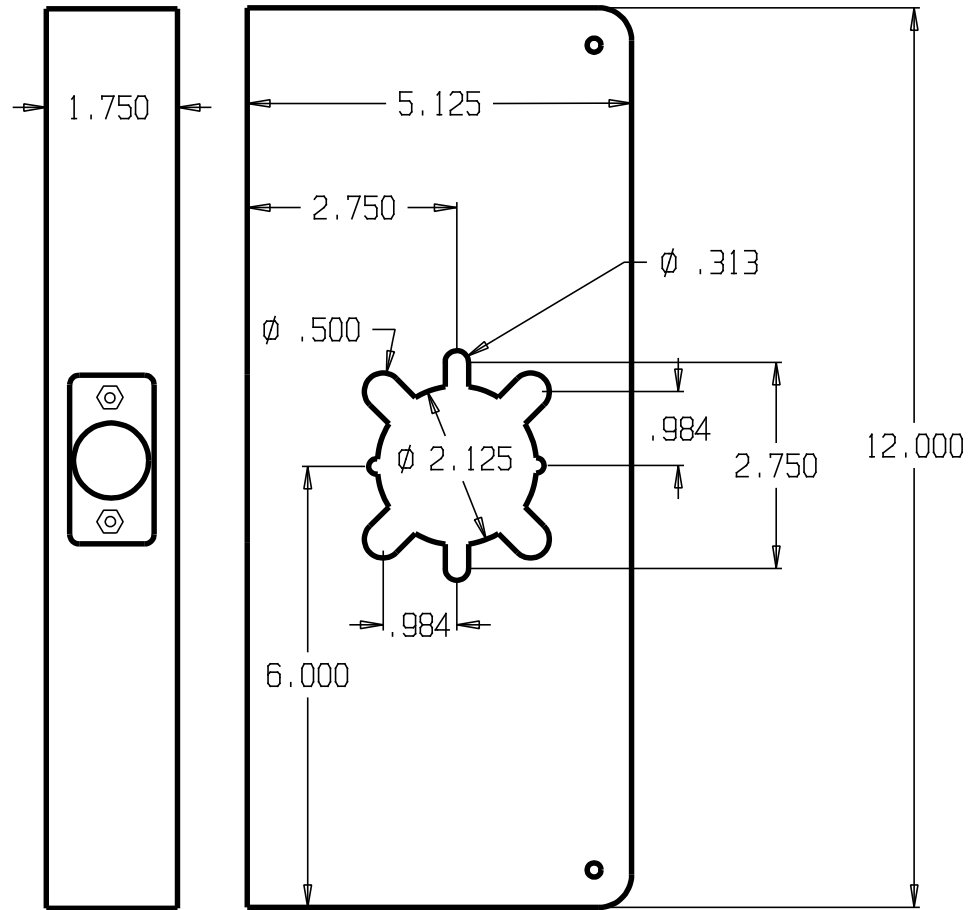

DON-JO MFG. INC.

| | | | | |
|----------|-----------|------------------|---------------------|-------|
| DESIGNER | SIZE A | DATE: 6/11/13 | PART NO. 12-2-CW | REV |
| APPROVED | SCALE | RELEASE DATE | WEIGHT | SHEET |

| REVISIONS | | | |
|-----------|-----|-----------|----------|
| ZONE | REV | FINISHES: | DATE |
| | | PB & S | |
| | | | APPROVED |

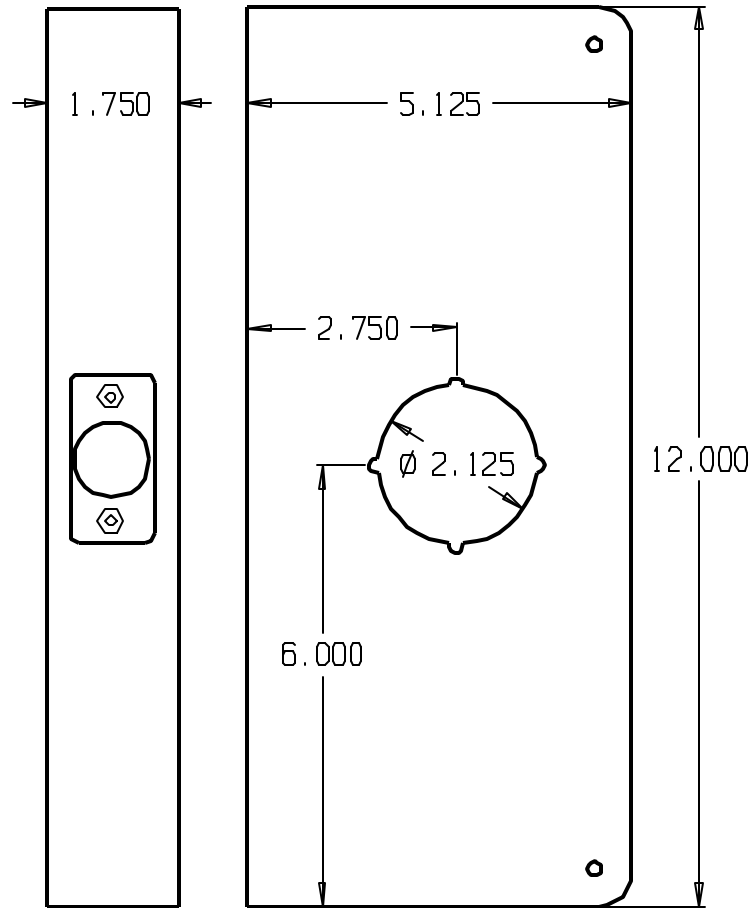

DON-JO MFG. INC.

| | | | | |
|----------|-------|--------------|----------|-------|
| DESIGNER | SIZE | DATE | PART NO. | REV |
| | A | 2/10/04 | 12-CW | |
| APPROVED | SCALE | RELEASE DATE | WEIGHT | SHEET |

| REVISIONS | | | | |
|-----------|-----|------------|------|----------|
| ZONE | REV | FINISHES: | DATE | APPROVED |
| | | PB, AB & S | | |

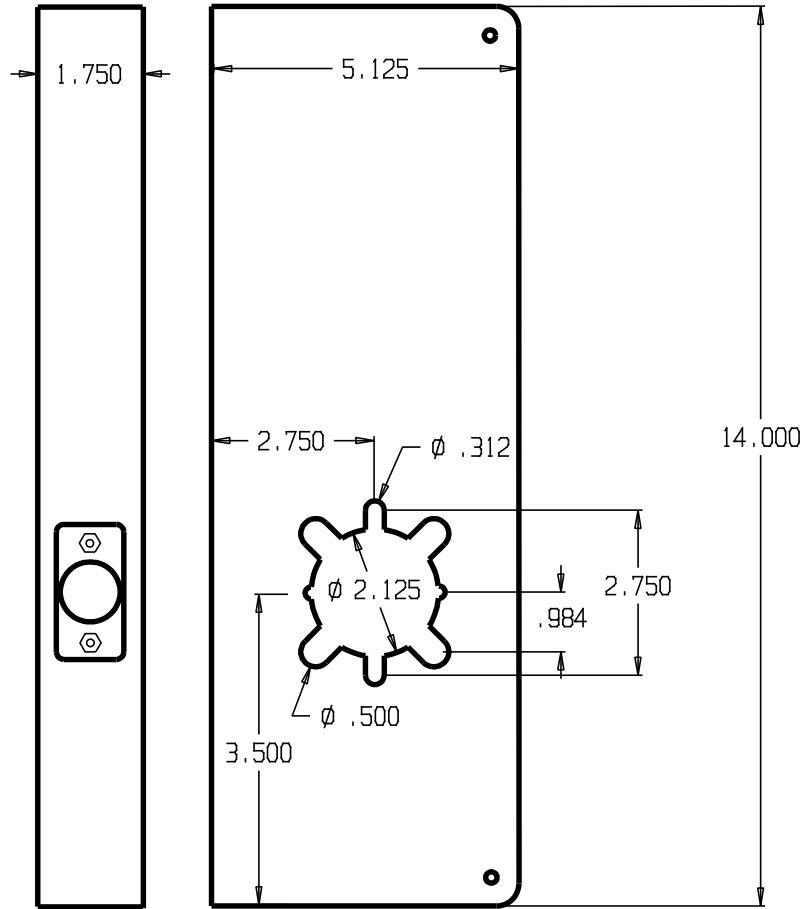

DON-JO MFG. INC.

| | | | | |
|----------|-------|--------------|----------|-------|
| DESIGNER | SIZE | DATE: | PART NO. | REV |
| | A | 2/10/04 | 14-2-CW | |
| APPROVED | SCALE | RELEASE DATE | WEIGHT | SHEET |

| REVISIONS | | | | |
|-----------|-----|------------|------|----------|
| ZONE | REV | FINISHES: | DATE | APPROVED |
| | | PB, AB & S | | |

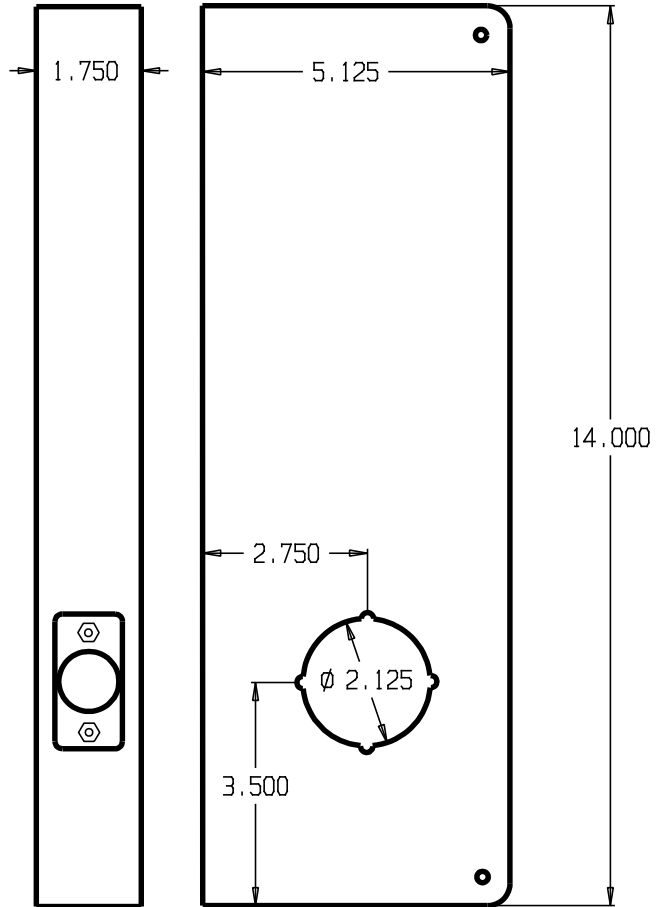

DON-JO MFG. INC.

| | | | | |
|----------|-----------|------------------|-------------------|-------|
| DESIGNER | SIZE A | DATE: 2/10/04 | PART NO. 14-CW | REV |
| APPROVED | SCALE | RELEASE DATE | WEIGHT | SHEET |

| REVISIONS | | | |
|-----------|-----|------------|------------|
| ZONE | REV | FINISHES: | GALUGE: |
| | | PB, AB & S | 22ga. .032 |

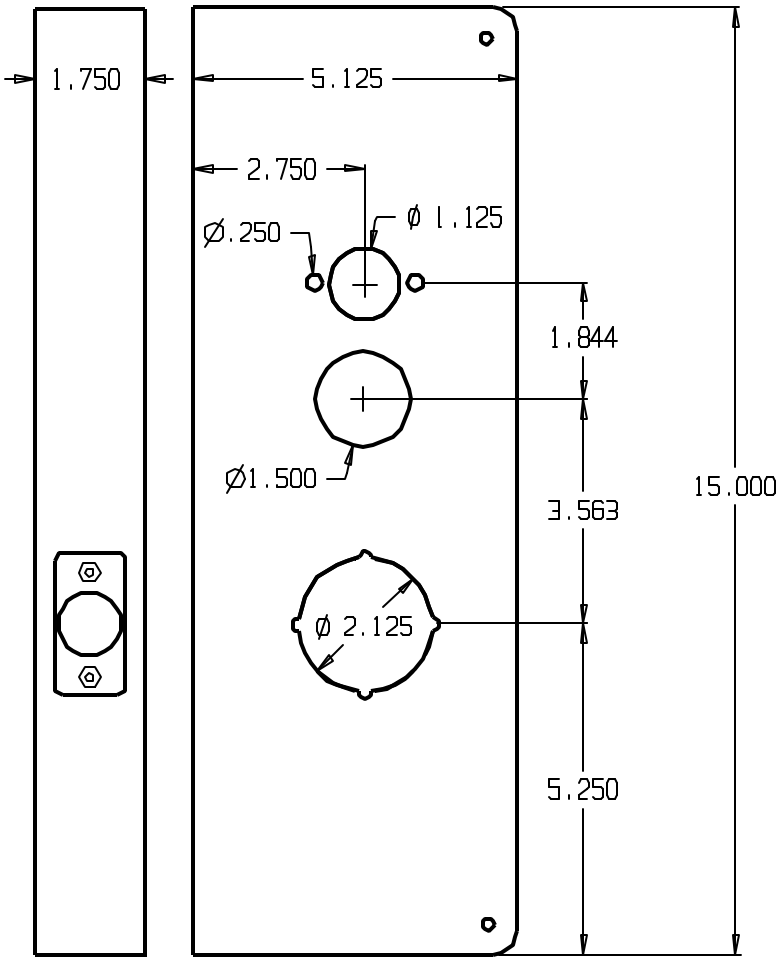

DON-JO MFG. INC.

| | | | | | |
|----------|--------------|--------|---------|----------|-----|
| DESIGNER | SCALE | SIZE | DATE | PART NO. | REV |
| | | A | 5/31/11 | 15-CW | |
| APPROVED | RELEASE DATE | WEIGHT | SHEET | | |

| REVISIONS | | | |
|-----------|-----|---------------------|------|
| ZONE | REV | FINISHES: | DATE |
| | | PB, AB, BZ, 10B & S | |
| | | APPROVED | |

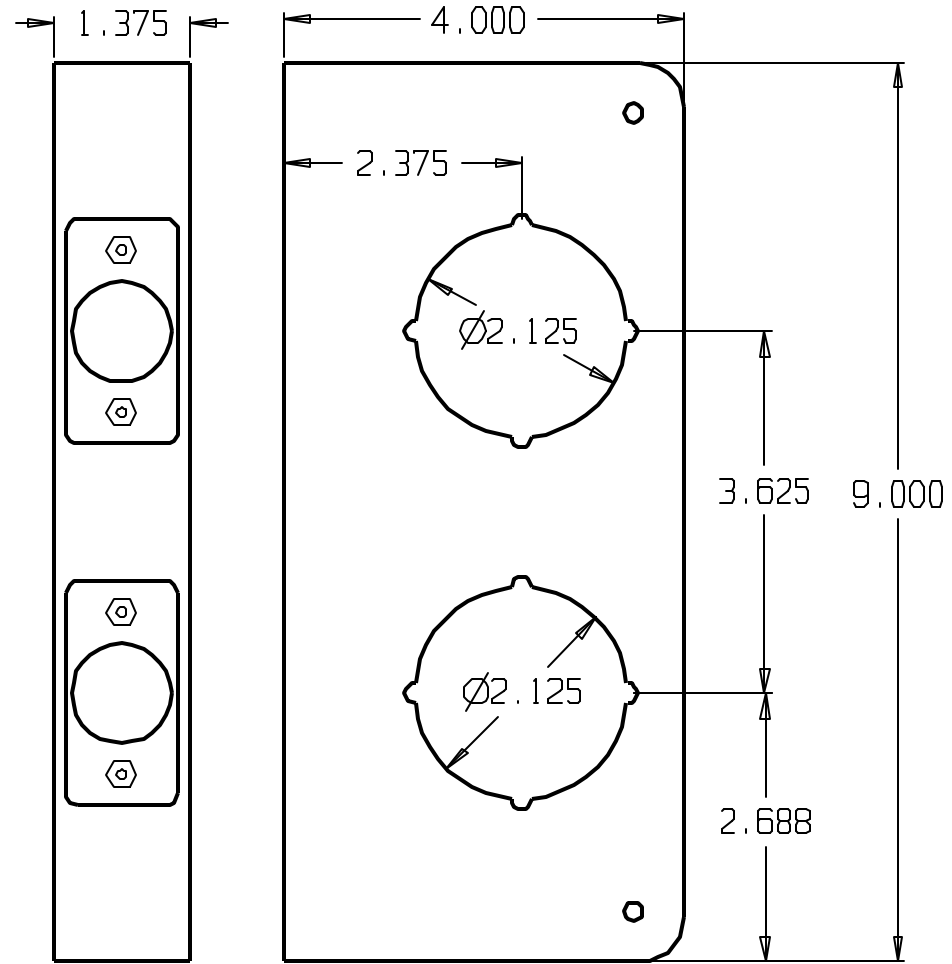

DON-JO MFG. INC.

| | | | | |
|----------|-------|--------------|----------|-------|
| DESIGNER | SIZE | DATE | PART NO. | REV |
| | A | 3/23/04 | 151-CW | |
| APPROVED | SCALE | RELEASE DATE | WEIGHT | SHEET |

| REVISIONS | | | |
|-----------|-----|---------------------|----------|
| ZONE | REV | FINISHES: | DATE |
| | | PB, AB, BZ, 10B & S | |
| | | | APPROVED |

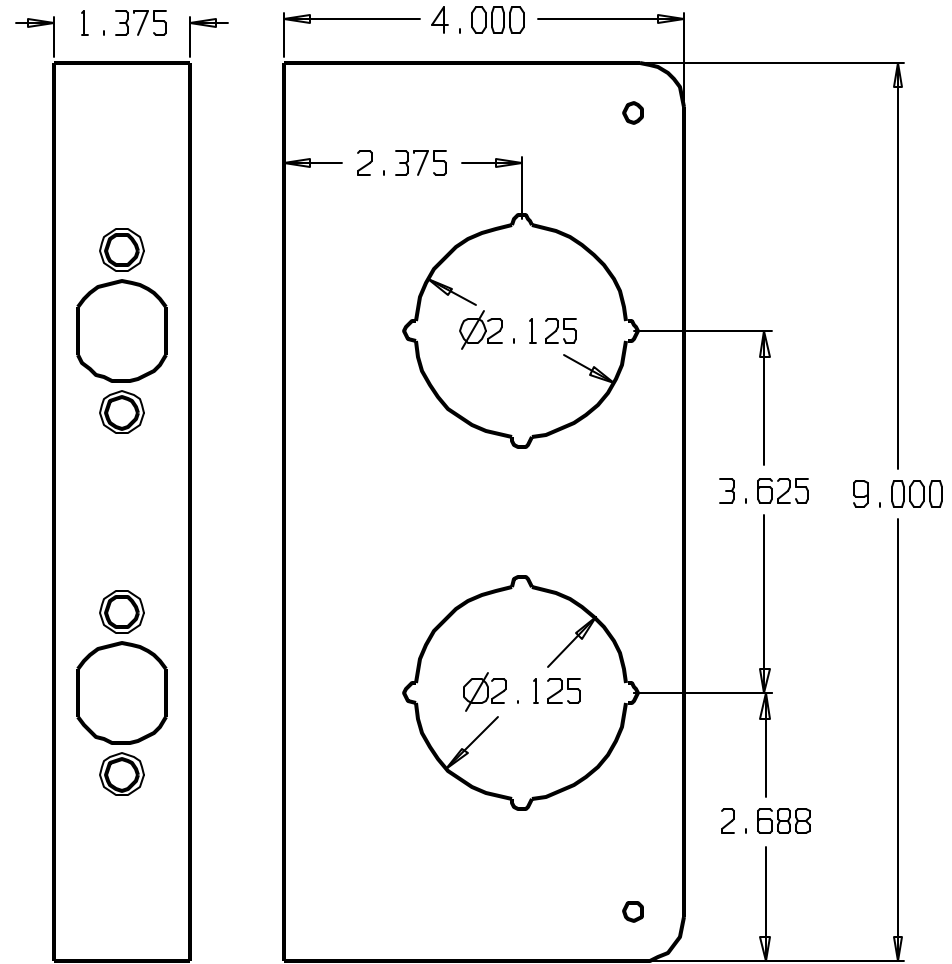

DON-JO MFG. INC.

| | | | | |
|----------|-------|--------------|----------|-------|
| DESIGNER | SIZE | DATE | PART NO. | REV |
| | A | 3/23/04 | 151-VF | |
| APPROVED | SCALE | RELEASE DATE | WEIGHT | SHEET |

| REVISIONS | | | |
|-----------|-----|---------------------|------|
| ZONE | REV | FINISHES: | DATE |
| | | PB, AB, BZ, 10B & S | |
| | | APPROVED | |

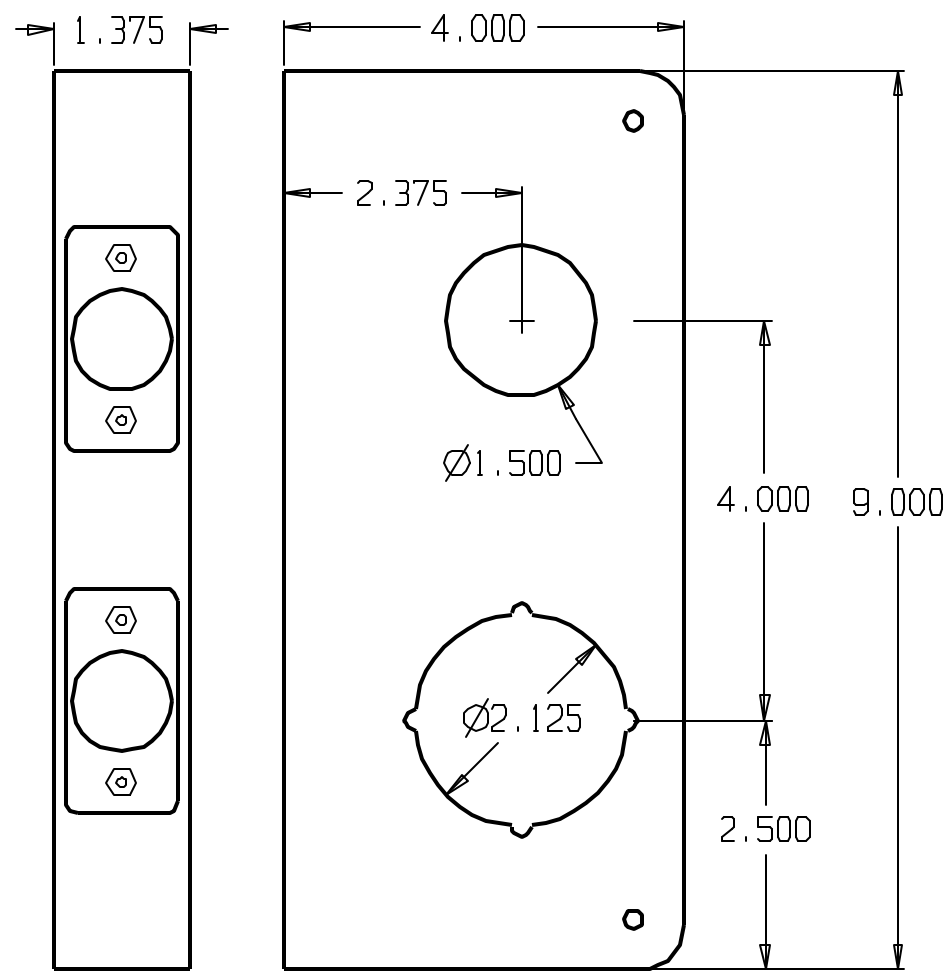

DON-JO MFG. INC.

| | | | | |
|----------|-------|--------------|----------|-------|
| DESIGNER | SIZE | DATE | PART NO. | REV |
| | A | 3/23/04 | 154-CW | |
| APPROVED | SCALE | RELEASE DATE | WEIGHT | SHEET |

| REVISIONS | | |
|-----------|-----|------------|
| ZONE | REV | FINISHES: |
| | | PB, AB & S |
| | | GALUGE: |
| | | 22ga. .032 |

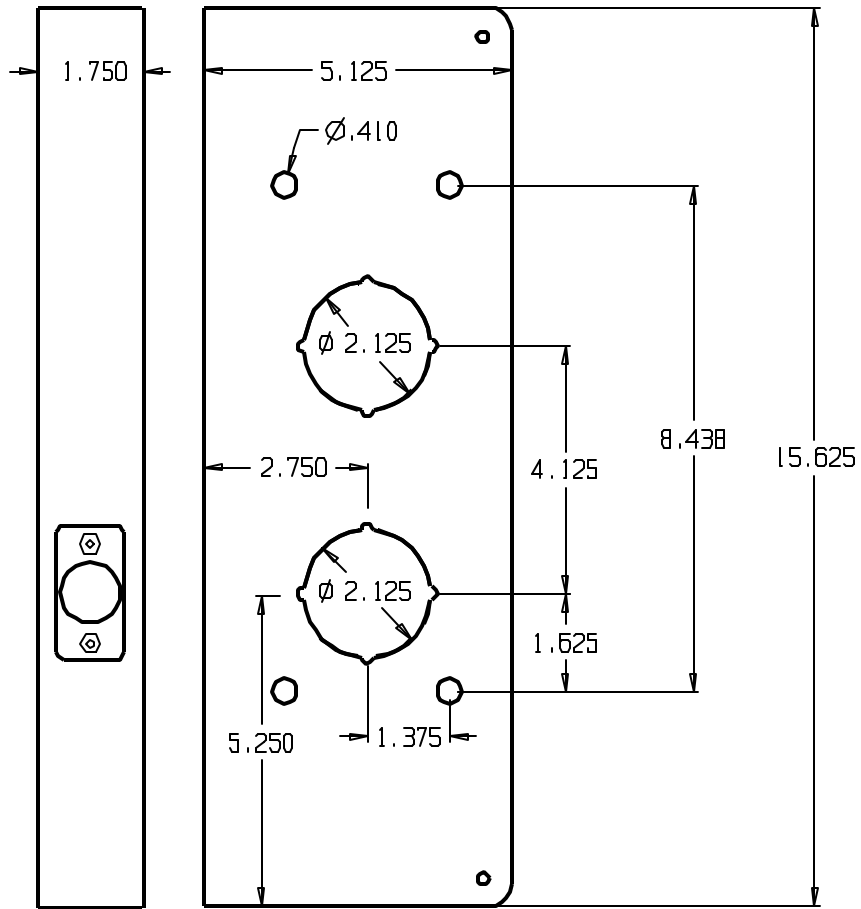

DON-JO MFG. INC.

DESIGNER
APPROVED

SIZE: A
DATE: 2/25/09
SCALE

PART NO.: 16-CW
RELEASE DATE
WEIGHT
SHEET

| REVISIONS | | | |
|-----------|-----|-----------|------------|
| ZONE | REV | FINISHES: | GUAGE: |
| | | PB & S | 22ga. .032 |

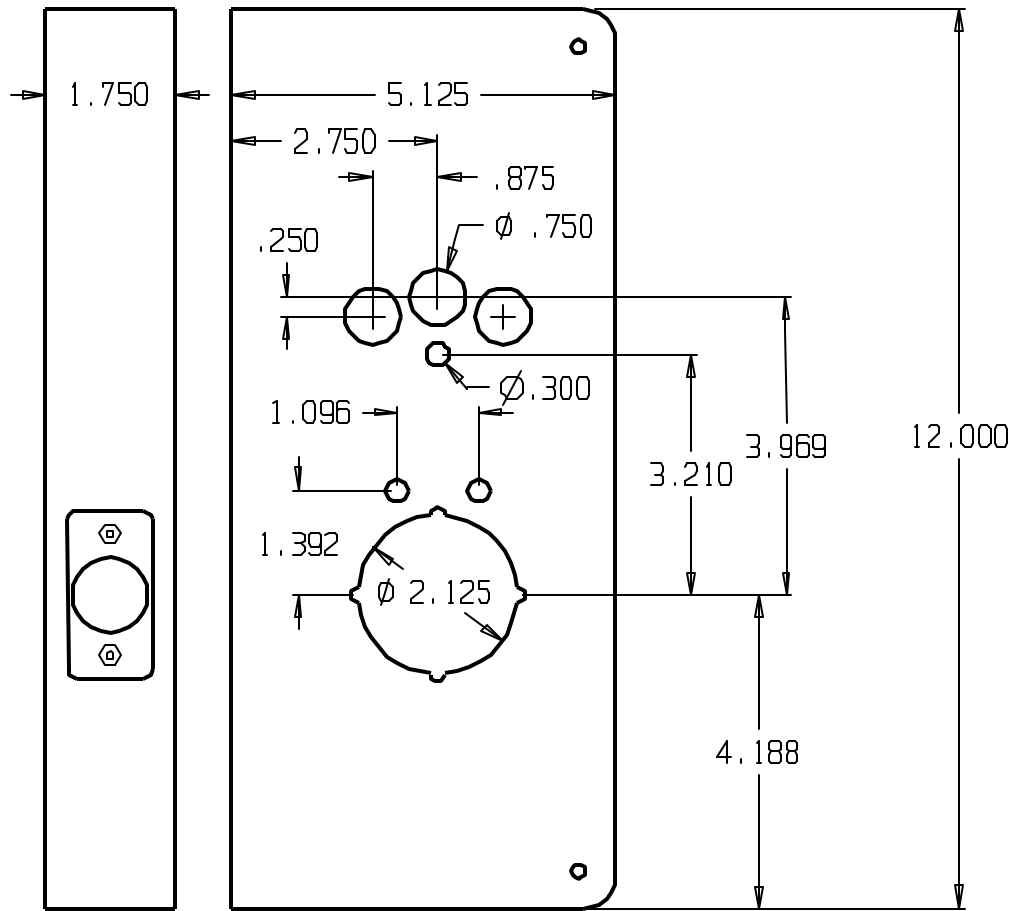

DON-JO MFG. INC.

| | | | | |
|----------|-------|--------------|----------|-------|
| DESIGNER | SIZE | DATE | PART NO. | REV |
| | A | 3/29/04 | 17-CW | |
| APPROVED | SCALE | RELEASE DATE | WEIGHT | SHEET |

| REVISIONS | | | |
|-----------|-----|-----------------|------------|
| ZONE | REV | FINISHES: | GAUGE: |
| | | PB, BZ, 10B & S | 22ga. .032 |

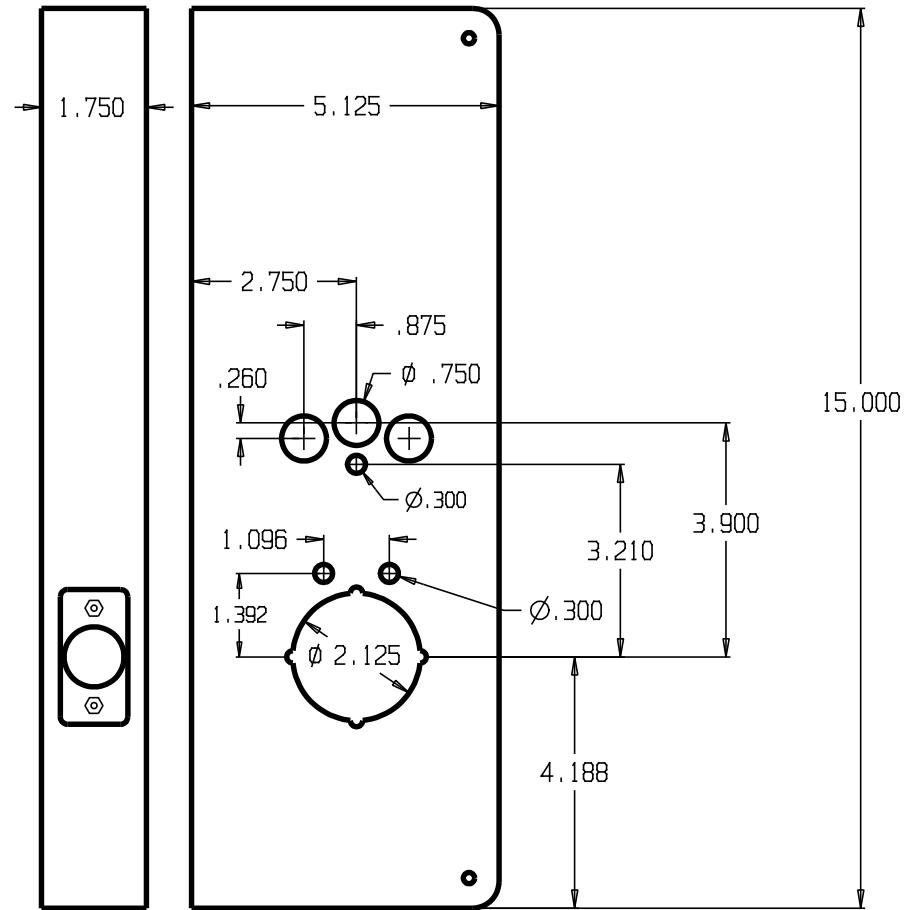

DON-JO MFG. INC.

| | | | | |
|----------|-----------|------------------|-------------------|-------|
| DESIGNER | SIZE A | DATE: 2/16/04 | PART NO. 18-CW | REV |
| APPROVED | SCALE | RELEASE DATE | WEIGHT | SHEET |

| REVISIONS | | | |
|-----------|-----|-----------|------------|
| ZONE | REV | FINISHES: | GALUGE: |
| | | PB & S | 22ga. .032 |

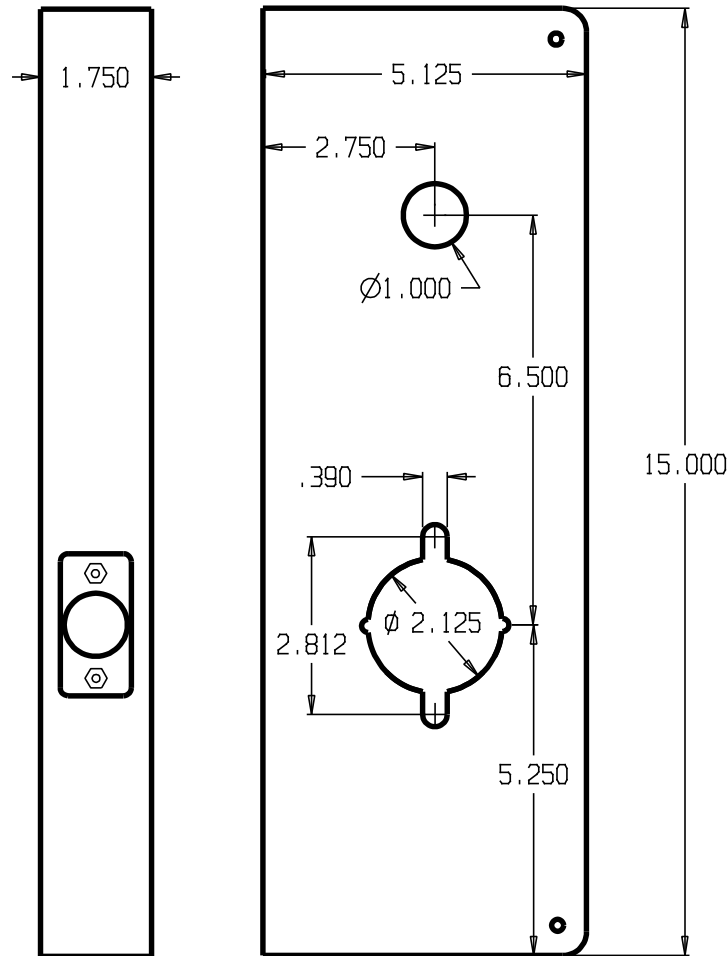

DON-JO MFG. INC.

| | | | | |
|----------|-------|--------------|----------|-------|
| DESIGNER | SIZE | DATE: | PART NO. | REV |
| | A | 4/1/04 | 19-CW | |
| APPROVED | SCALE | RELEASE DATE | WEIGHT | SHEET |
| | | | | |

| REVISIONS | | |
|-----------|-----|--------------------|
| ZONE | REV | FINISHES: |
| | | 10B, AB, BZ, PB, S |
| | | GALUGE: |
| | | 22ga. .032 |

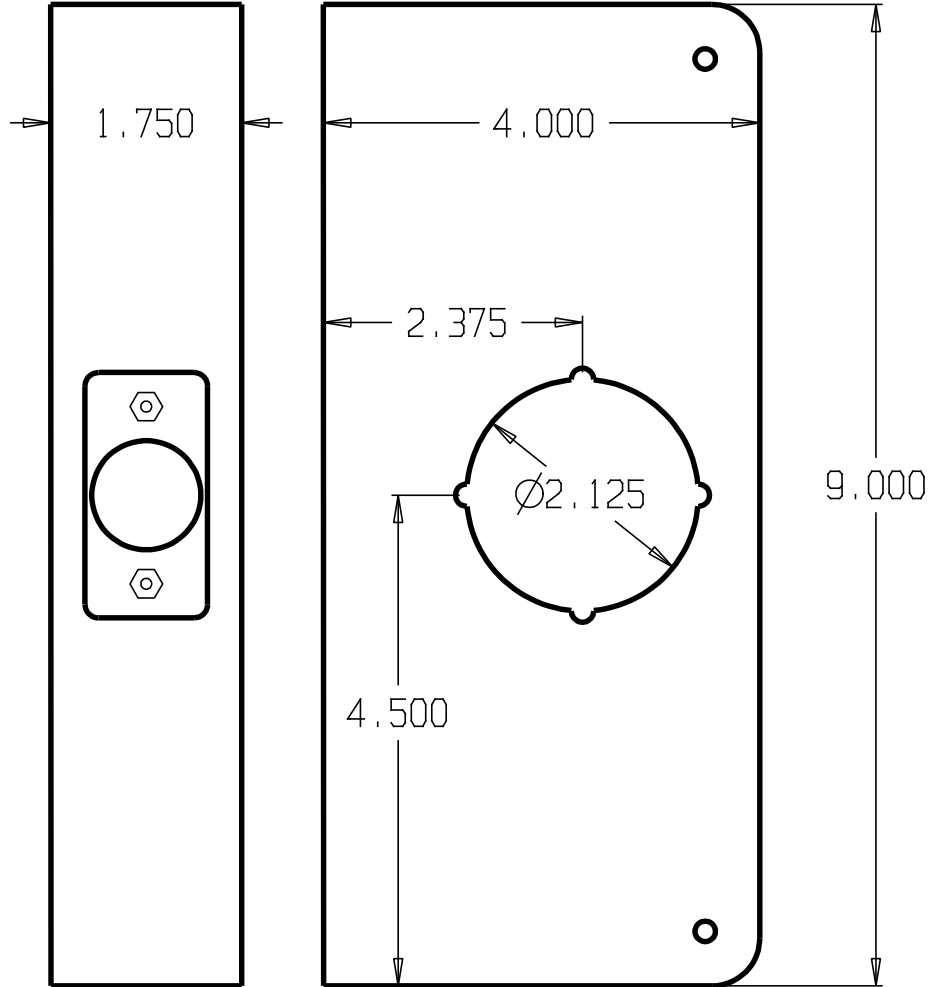

DON-JO MFG. INC.

| | | | | |
|----------|-----------|-----------------|------------------|-------|
| DESIGNER | SIZE A | DATE: 4/1/04 | PART NO. 2-CW | REV |
| APPROVED | SCALE | RELEASE DATE | WEIGHT | SHEET |

| REVISIONS | | | |
|-----------|-----|-----------|------------|
| ZONE | REV | FINISHES: | GALUGE: |
| | | PB & S | 22ga. .032 |

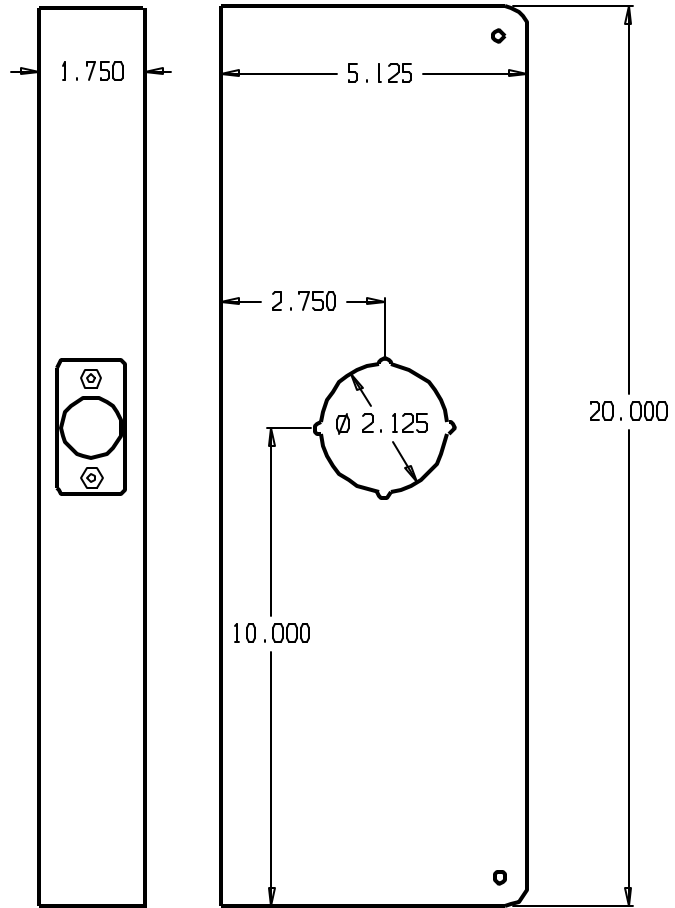

DON-JO MFG. INC.

DESIGNER
APPROVED

| | | | |
|-----------|----------------|-------------------|-------|
| SIZE A | DATE 4/1/04 | PART NO. 20-CW | REV |
| SCALE | RELEASE DATE | WEIGHT | SHEET |

| REVISIONS | | | | |
|-----------|-----|------------|------|----------|
| ZONE | REV | FINISHES: | DATE | APPROVED |
| | | PB, AB & S | | |

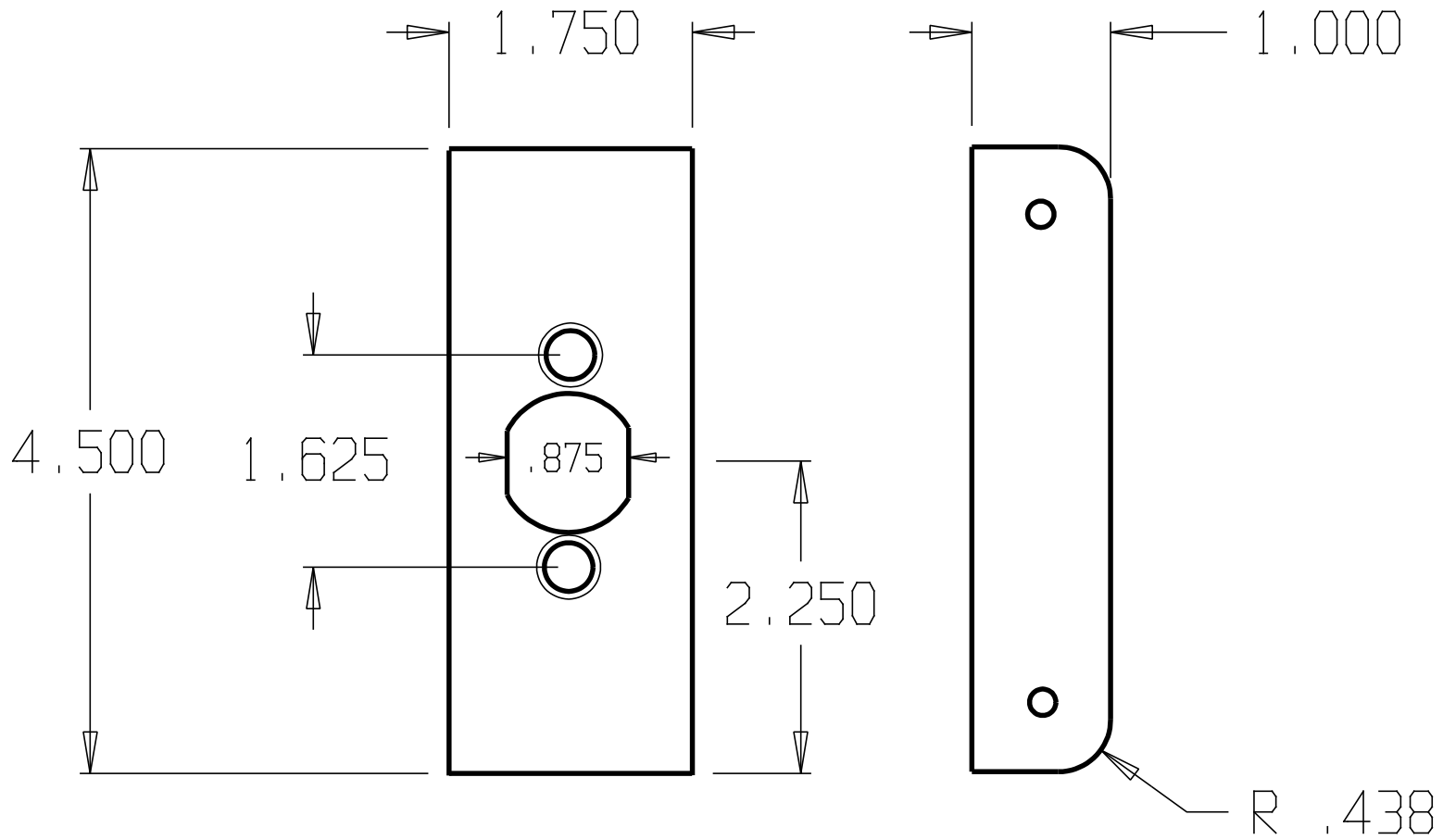

DON-JO MFG. INC.

| | |
|----------|--|
| DESIGNER | |
| APPROVED | |

| | | | |
|-----------|-----------------|-------------------|-------|
| SIZE A | DATE: 4/5/04 | PART NO. 20-FE | REV |
| SCALE | RELEASE DATE | WEIGHT | SHEET |

| REVISIONS | | | |
|-----------|-----|-----------|------|
| ZONE | REV | FINISHES: | DATE |
| | | PB & S | |
| | | APPROVED | |

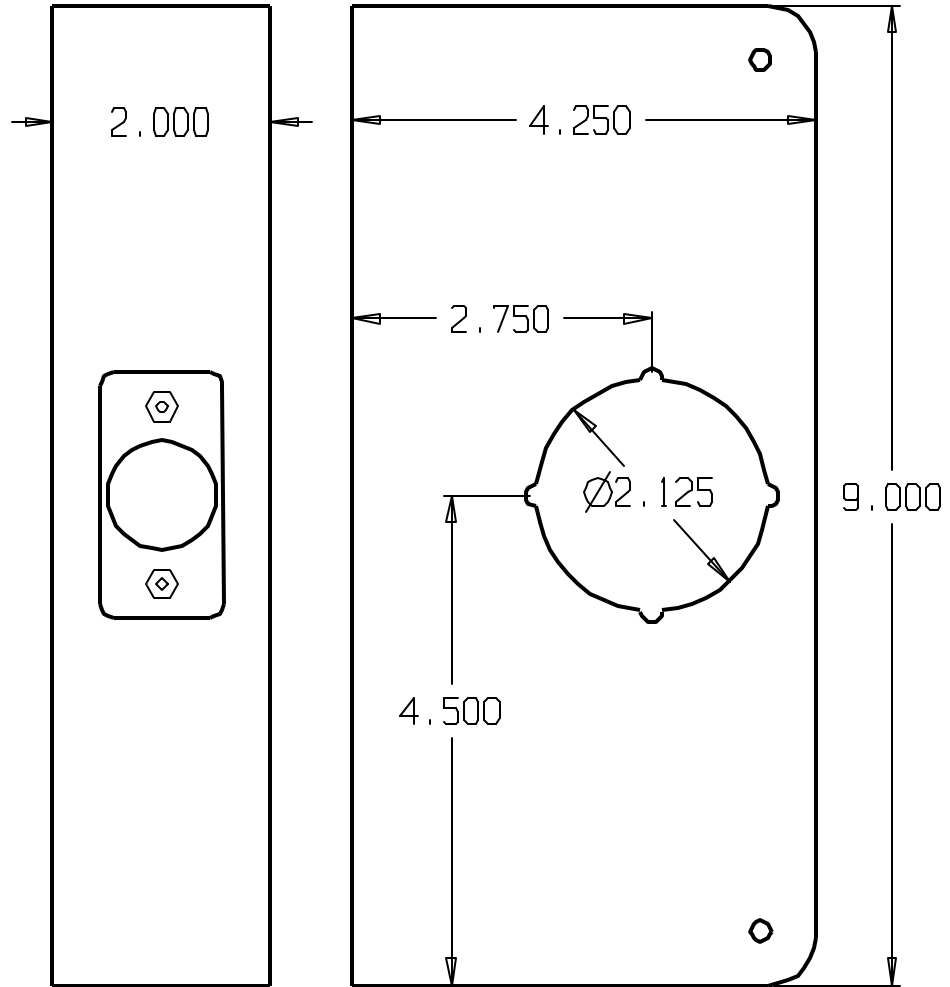

DON-JO MFG. INC.

| | | | | |
|----------|-------|--------------|----------|-------|
| DESIGNER | SIZE | DATE | PART NO. | REV |
| | A | 4/5/04 | 200-CW | |
| APPROVED | SCALE | RELEASE DATE | WEIGHT | SHEET |
| | | | | |

| REVISIONS | | | |
|-----------|-----|-----------|----------|
| ZONE | REV | FINISHES: | DATE |
| | | PB & S | |
| | | | APPROVED |

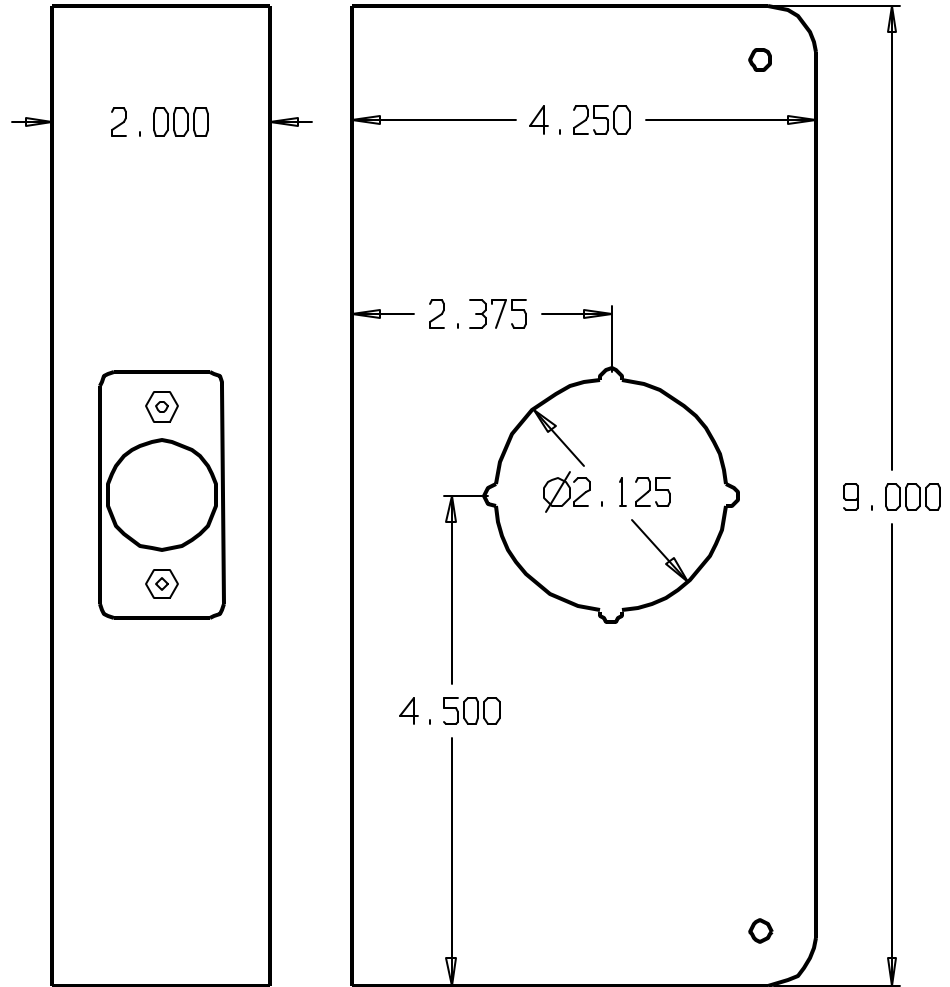

DON-JO MFG. INC.

| | | | | |
|----------|-------|--------------|----------|-------|
| DESIGNER | SIZE | DATE | PART NO. | REV |
| | A | 4/5/04 | 200C-CW | |
| APPROVED | SCALE | RELEASE DATE | WEIGHT | SHEET |

REVISIONS

| | | | |
|------|-----|------------------|--------------------|
| ZONE | REV | FINISHES: PB & S | GALUGE: 22ga. .032 |
|------|-----|------------------|--------------------|

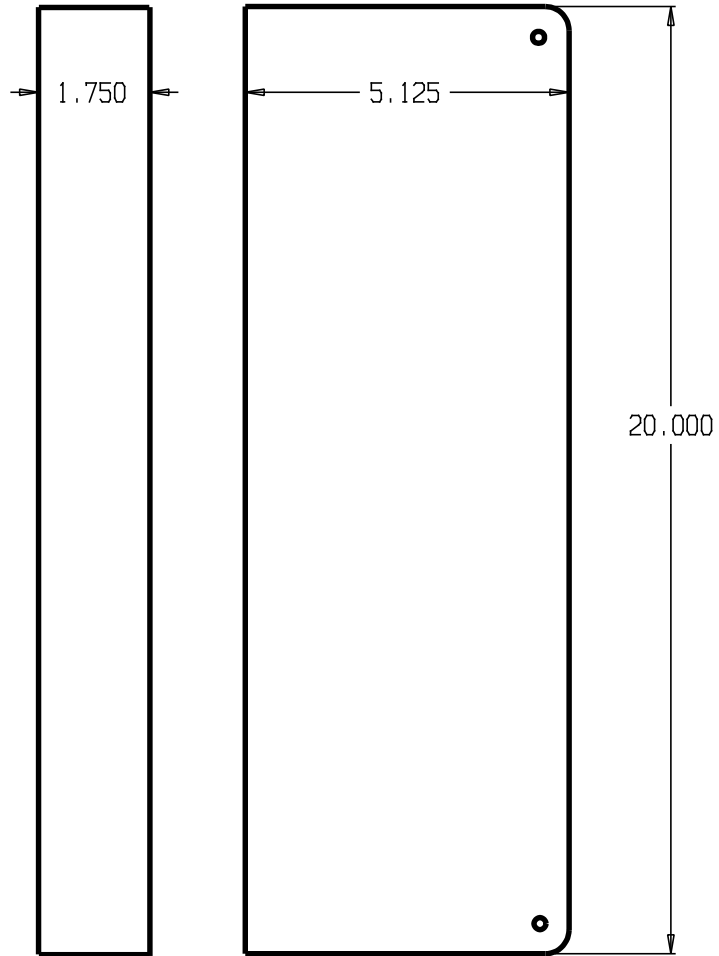

DON-JO MFG. INC.

| | | | | |
|----------|---------|--------------|-----------------|-------|
| DESIGNER | SIZE: A | DATE: 4/5/04 | PART NO. 20B-CW | REV |
| APPROVED | SCALE | RELEASE DATE | WEIGHT | SHEET |

| REVISIONS | | | |
|-----------|-----|-----------|------------|
| ZONE | REV | FINISHES: | GUAGE: |
| | | PB & S | 22ga. .032 |

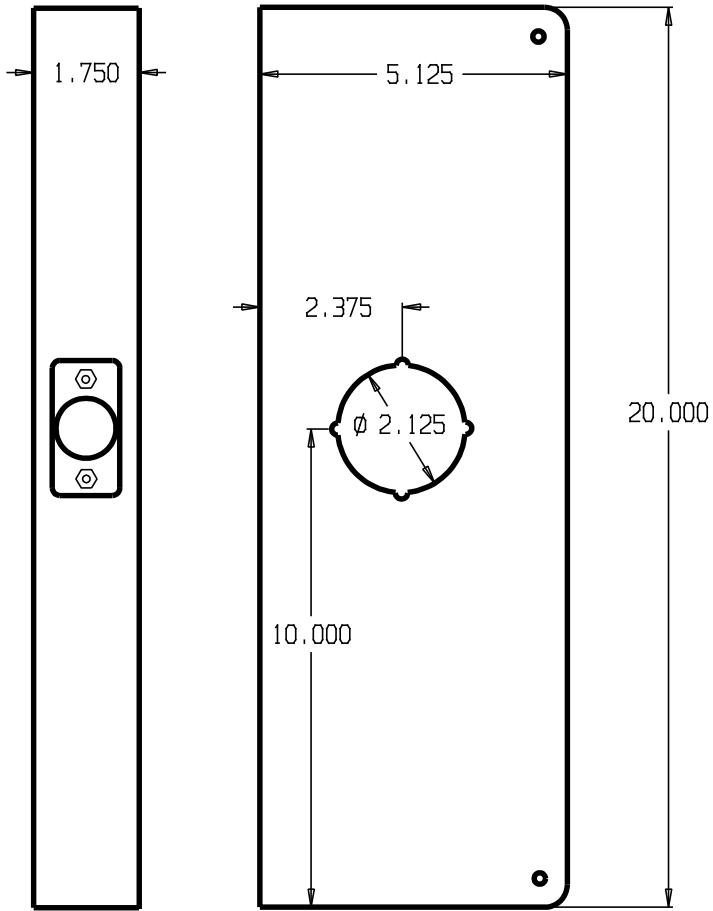

DON-JO MFG. INC.

| | |
|----------|----------|
| DESIGNER | APPROVED |
|----------|----------|

| | | | |
|-----------|-----------------|--------------------|-------|
| SIZE A | DATE: 4/1/04 | PART NO. 20C-CW | REV |
| SCALE | RELEASE DATE | WEIGHT | SHEET |

| REVISIONS | | | | |
|-----------|-----|-----------|------|----------|
| ZONE | REV | FINISHES: | DATE | APPROVED |
| | | 605,630 | | |

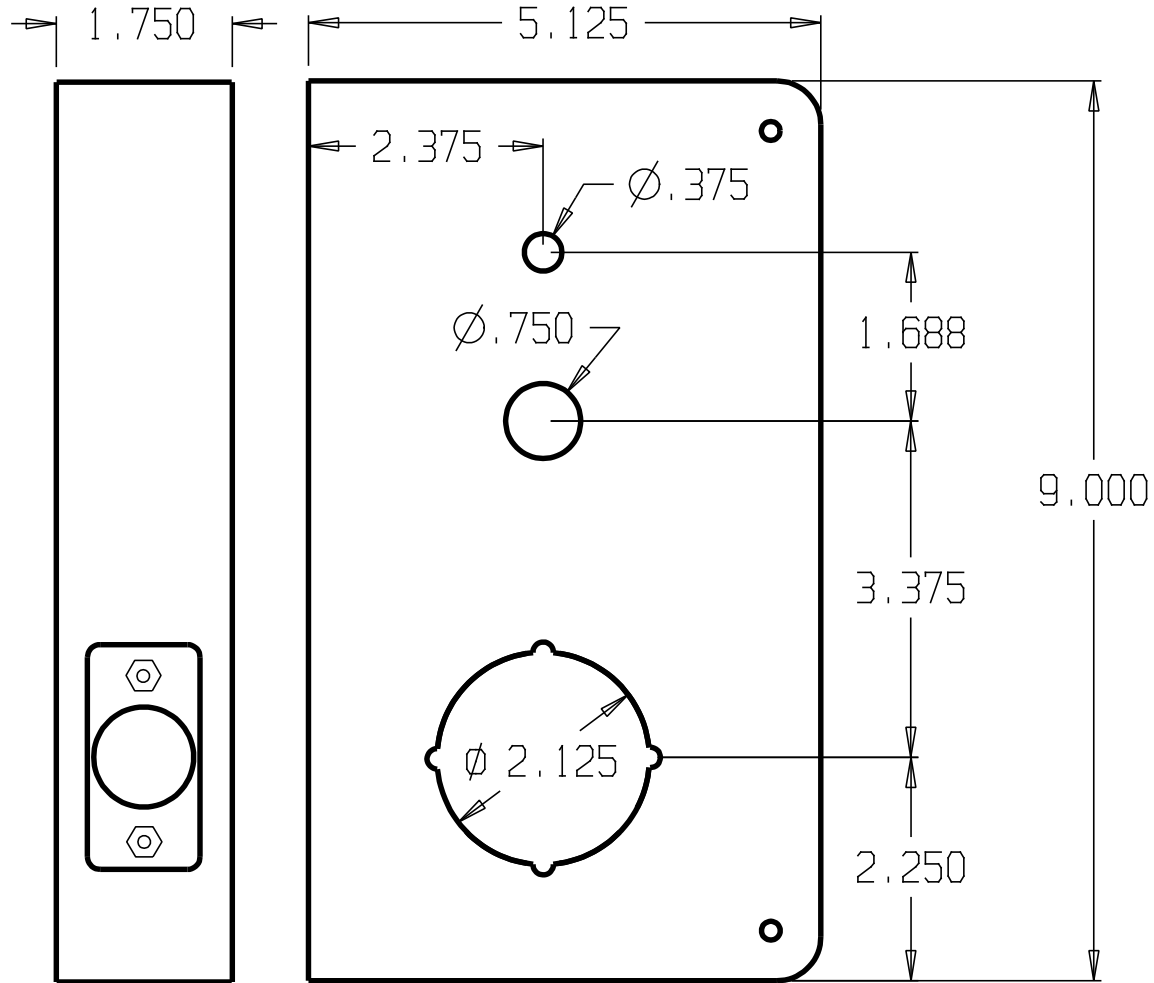

DON-JO MFG. INC.

| | | | | |
|----------|-----------|-------------------|-------------------|-------|
| DESIGNER | SIZE A | DATE: 12/20/05 | PART NO. 21-CW | REV |
| APPROVED | SCALE | RELEASE DATE | WEIGHT | SHEET |

| REVISIONS | | | |
|-----------|-----|-----------|----------|
| ZONE | REV | FINISHES: | DATE |
| | | PB & S | |
| | | | APPROVED |

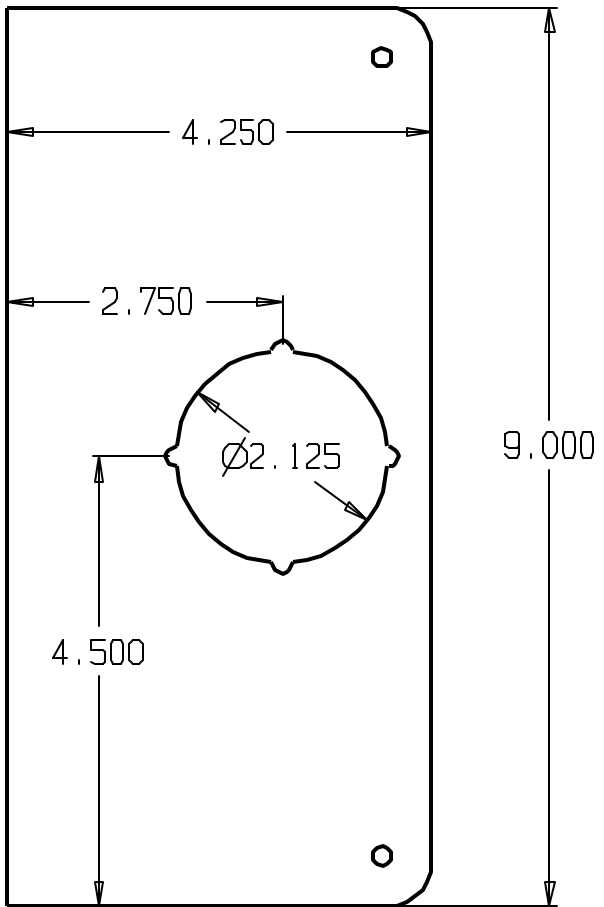
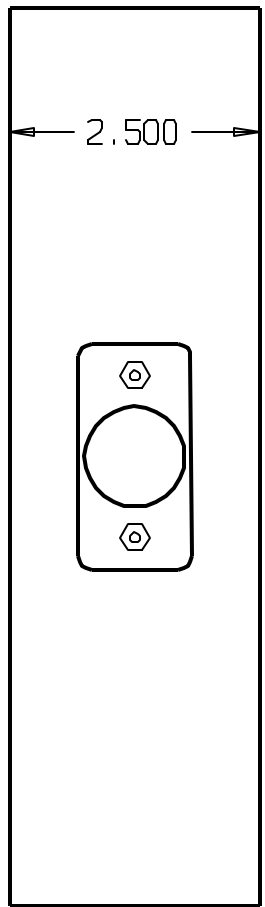

DON-JO MFG. INC.

| | | | | |
|----------|-------|--------------|----------|-------|
| DESIGNER | SIZE | DATE | PART NO. | REV |
| | A | 4/5/04 | 212-CW | |
| APPROVED | SCALE | RELEASE DATE | WEIGHT | SHEET |

| REVISIONS | | | |
|-----------|-----|-----------|----------|
| ZONE | REV | FINISHES: | DATE |
| | | PB & S | |
| | | | APPROVED |

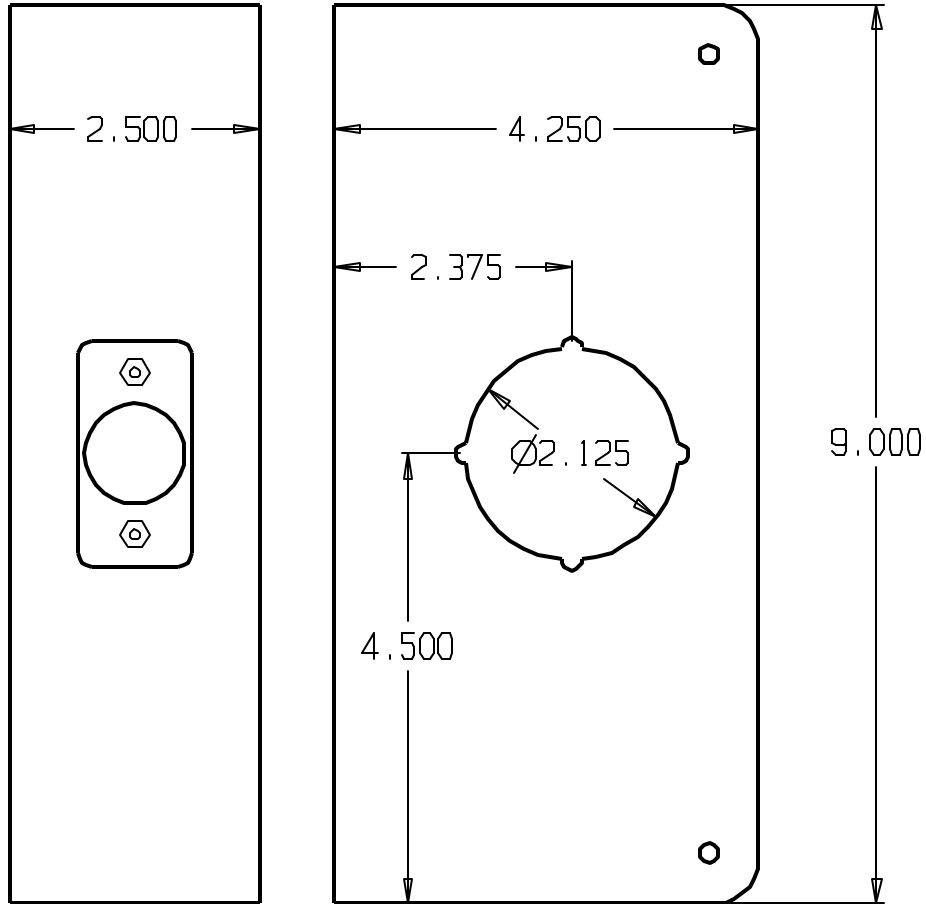

DON-JO MFG. INC.

| | | | | |
|----------|-------|--------------|----------|-------|
| DESIGNER | SIZE | DATE | PART NO. | REV |
| | A | 4/5/04 | 212C-CW | |
| APPROVED | SCALE | RELEASE DATE | WEIGHT | SHEET |

| REVISIONS | | | |
|-----------|-----|-----------|----------|
| ZONE | REV | FINISHES: | DATE |
| | | PB & S | |
| | | | APPROVED |

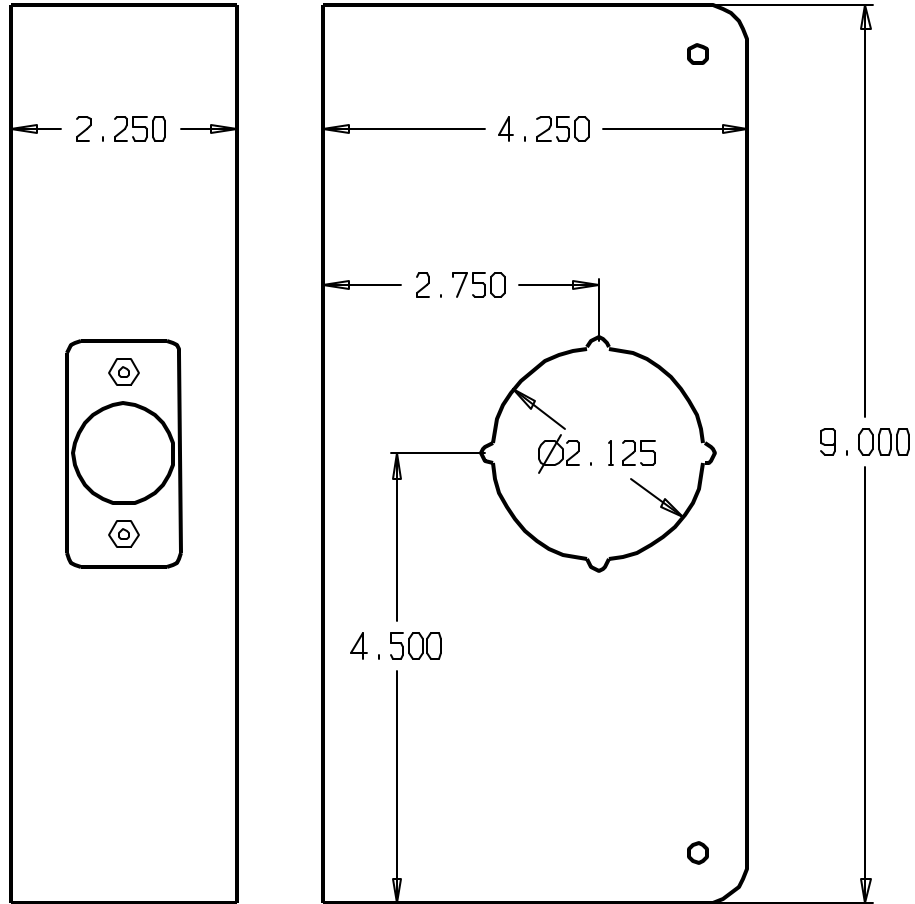

DON-JO MFG. INC.

| | | | | |
|----------|-------|--------------|----------|-------|
| DESIGNER | SIZE | DATE | PART NO. | REV |
| | A | 4/5/04 | 214-CW | |
| APPROVED | SCALE | RELEASE DATE | WEIGHT | SHEET |

| REVISIONS | | | |
|-----------|-----|-----------|----------|
| ZONE | REV | FINISHES: | DATE |
| | | PB & S | |
| | | | APPROVED |

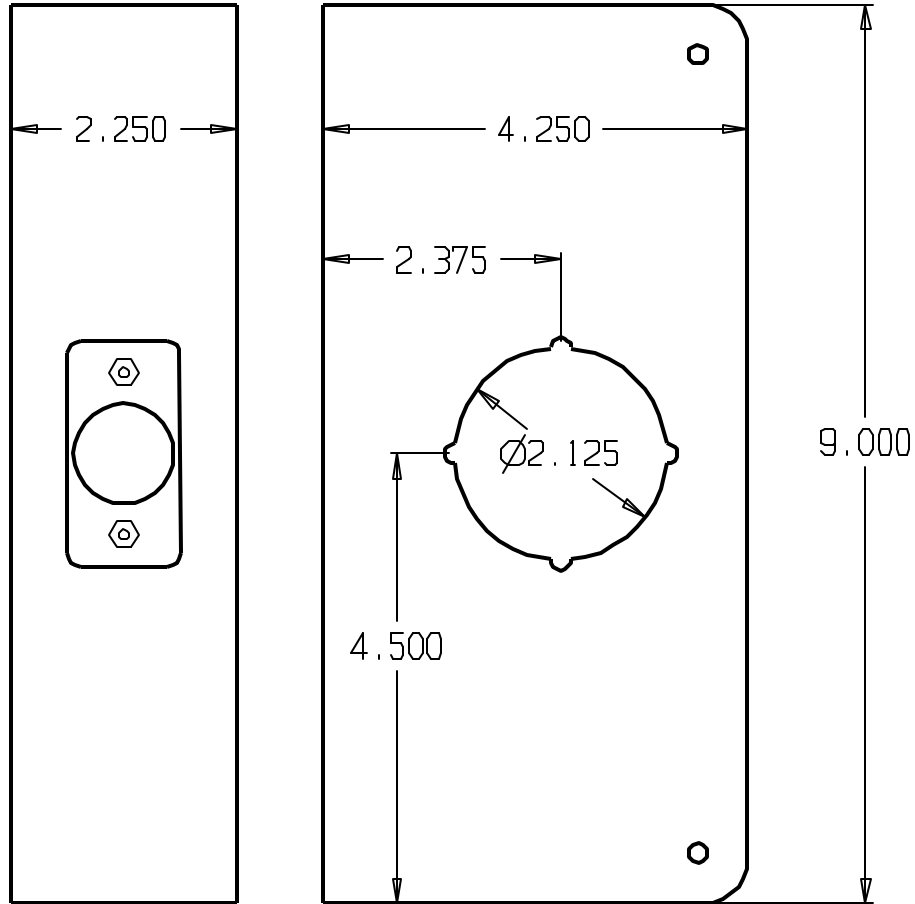

DON-JO MFG. INC.

| | | | | |
|----------|-------|--------------|----------|-------|
| DESIGNER | SIZE | DATE | PART NO. | REV |
| | A | 4/5/04 | 214C-CW | |
| APPROVED | SCALE | RELEASE DATE | WEIGHT | SHEET |

| REVISIONS | | |
|-----------|-----|-----------|
| ZONE | REV | FINISHES: |
| | | 605,630 |
| | | GAUGE: |

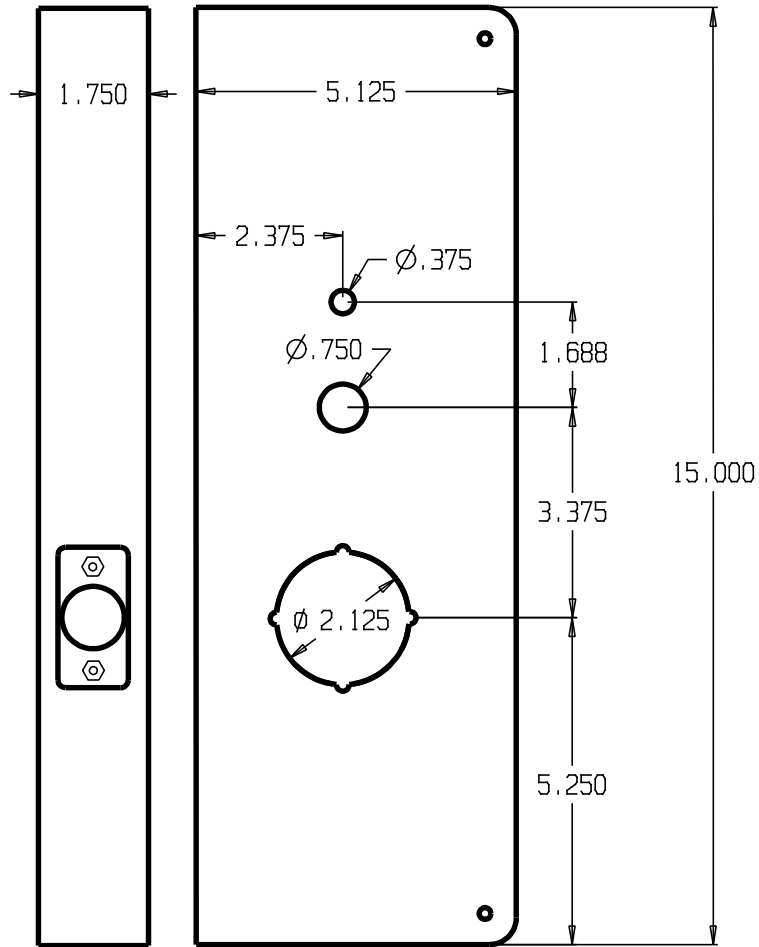

| | | | | | |
|------------------|------|-------|--------------|----------|-------|
| DON-JO MFG. INC. | | SIZE | DATE: | PART NO. | REV |
| DESIGNER | D.R. | A | 12/20/05 | 22-CW | |
| | | SCALE | RELEASE DATE | WEIGHT | SHEET |

| REVISIONS | | | | |
|-----------|-----|-----------|------|----------|
| ZONE | REV | FINISHES: | DATE | APPROVED |
| | | 605,630 | | |

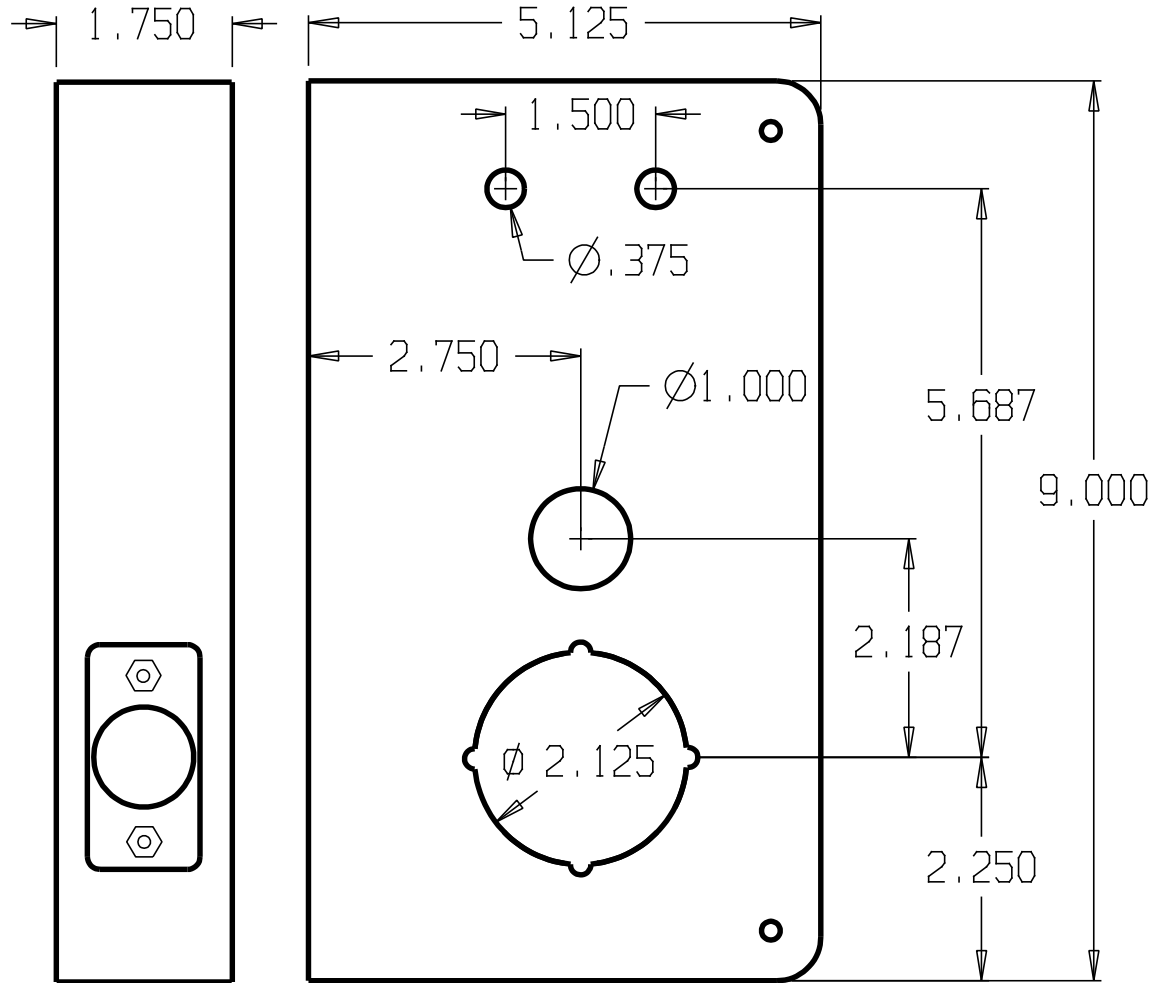

| | | | | | |
|------------------|--|-------|--------------|----------|-------|
| DON-JO MFG. INC. | | SIZE | DATE: | PART NO. | REV |
| DESIGNER | | A | 12/20/05 | 23-CW | |
| APPROVED | | SCALE | RELEASE DATE | WEIGHT | SHEET |

| REVISIONS | | |
|-----------|-----|-----------|
| ZONE | REV | FINISHES: |
| | | 605,630 |
| | | GAUGE: |

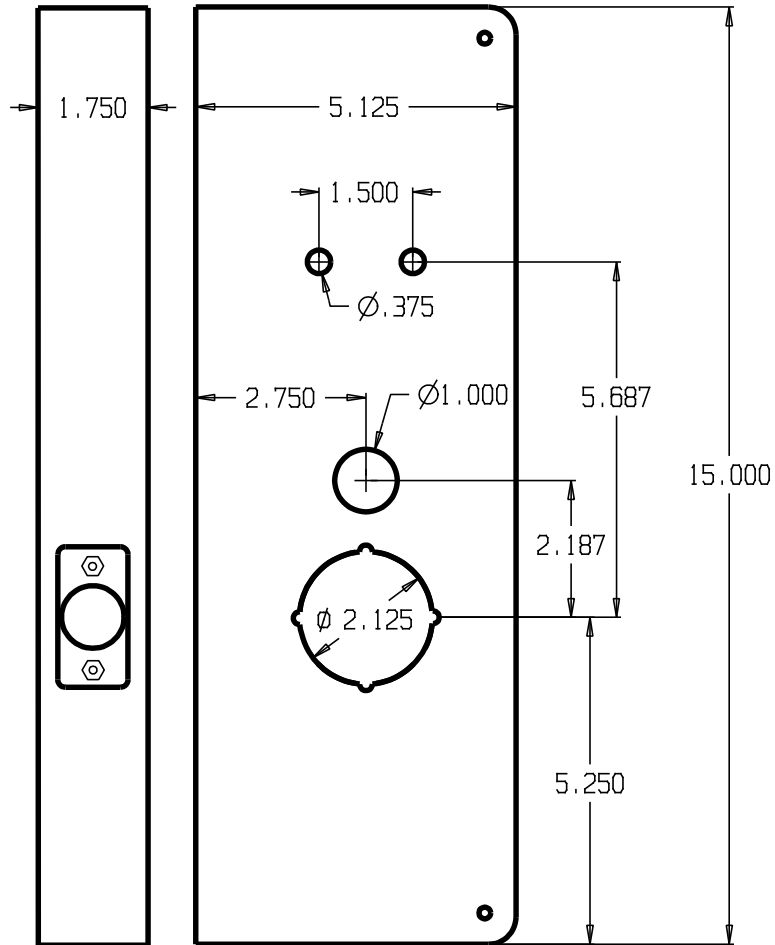

| | | | | | | | |
|------------------|------|-------|--------------|--------|-------|----------|-----|
| DON-JO MFG. INC. | | | | SIZE | DATE: | PART NO. | REV |
| DESIGNER | D.R. | A | 12/20/05 | 24-CW | | | |
| | | SCALE | RELEASE DATE | WEIGHT | SHEET | | |

| REVISIONS | | | |
|-----------|-----|-------------------------|------|
| ZONE | REV | FINISHES: | DATE |
| | | 605, 609, 612, 613, 630 | |
| | | APPROVED | |

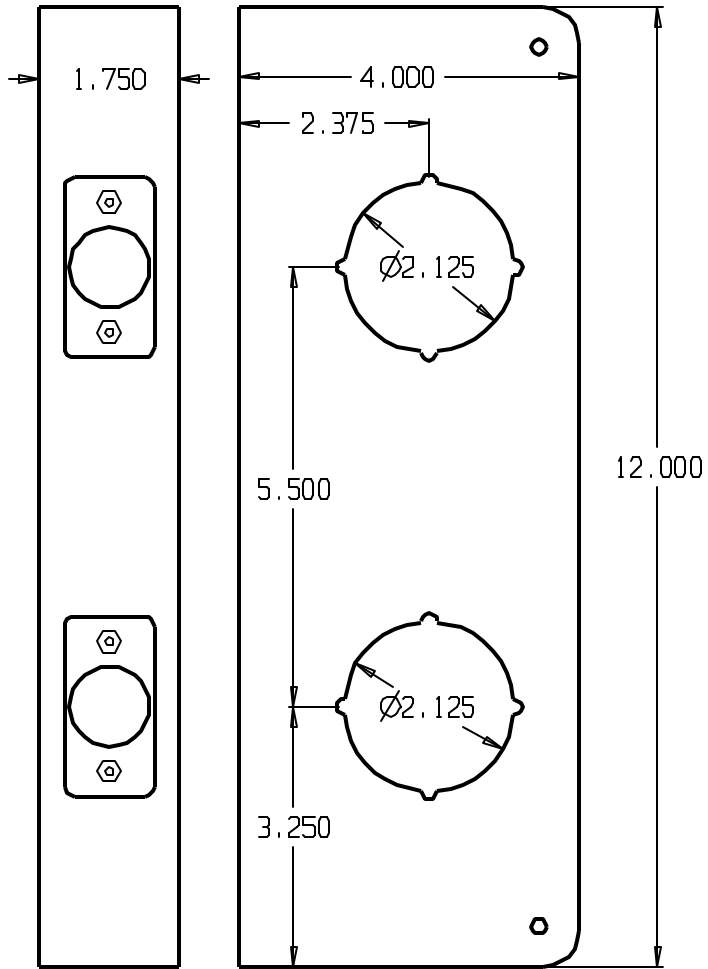

DON-JO MFG. INC.

| | | | | |
|----------|-----------|----------------|--------------------|-------|
| DESIGNER | SIZE A | DATE 4/5/04 | PART NO. 256-CW | REV |
| APPROVED | SCALE | RELEASE DATE | WEIGHT | SHEET |

| REVISIONS | | | |
|-----------|-----|-------------------------|------|
| ZONE | REV | FINISHES: | DATE |
| | | 605, 609, 612, 613, 630 | |
| | | APPROVED | |

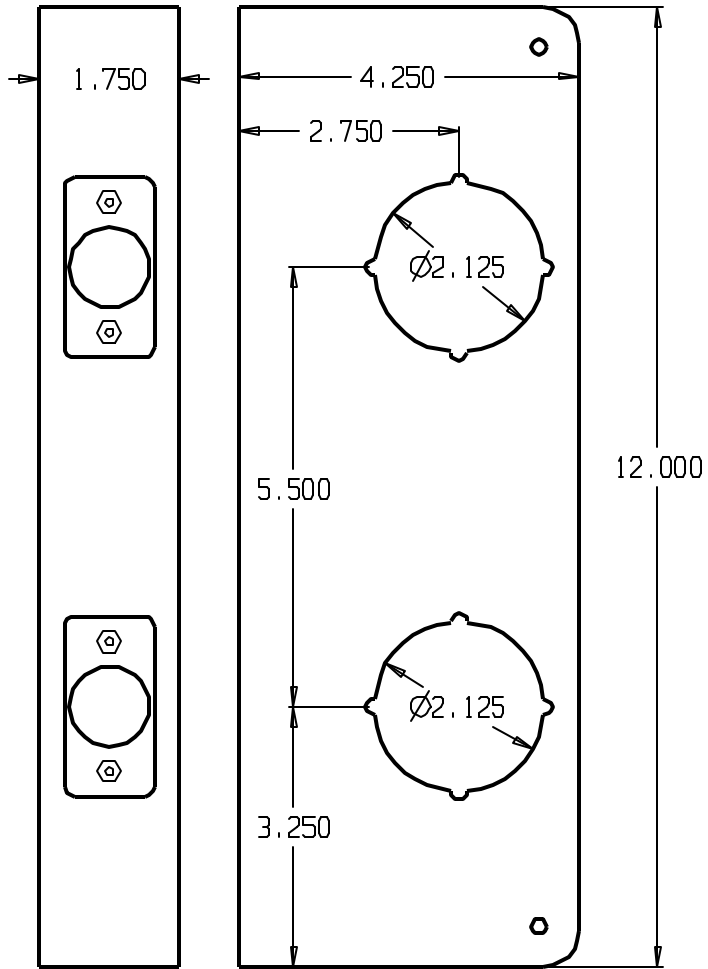

DON-JO MFG. INC.

| | | | | |
|----------|-----------|----------------|--------------------|-------|
| DESIGNER | SIZE A | DATE 4/5/04 | PART NO. 258-CW | REV |
| APPROVED | SCALE | RELEASE DATE | WEIGHT | SHEET |

| REVISIONS | | | |
|-----------|-----|---------------------|----------|
| ZONE | REV | FINISHES: | DATE |
| | | PB, AB, BZ, 10B & S | |
| | | | APPROVED |

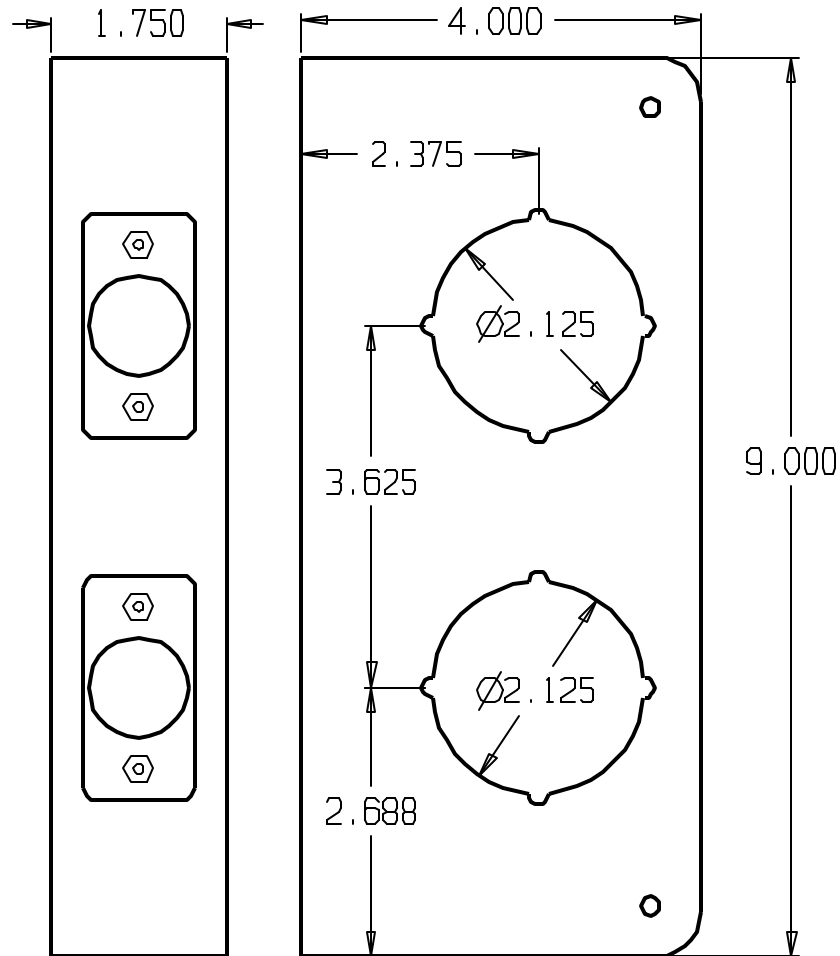

DON-JO MFG. INC.

| | |
|----------|--|
| DESIGNER | |
| APPROVED | |

| | | | |
|-------|--------------|----------|-------|
| SIZE | DATE | PART NO. | REV |
| A | 4/5/04 | 261-CW | |
| SCALE | RELEASE DATE | WEIGHT | SHEET |

| REVISIONS | | | |
|-----------|-----|---------------------|----------|
| ZONE | REV | FINISHES: | DATE |
| | | PB, AB, BZ, 10B & S | |
| | | | APPROVED |

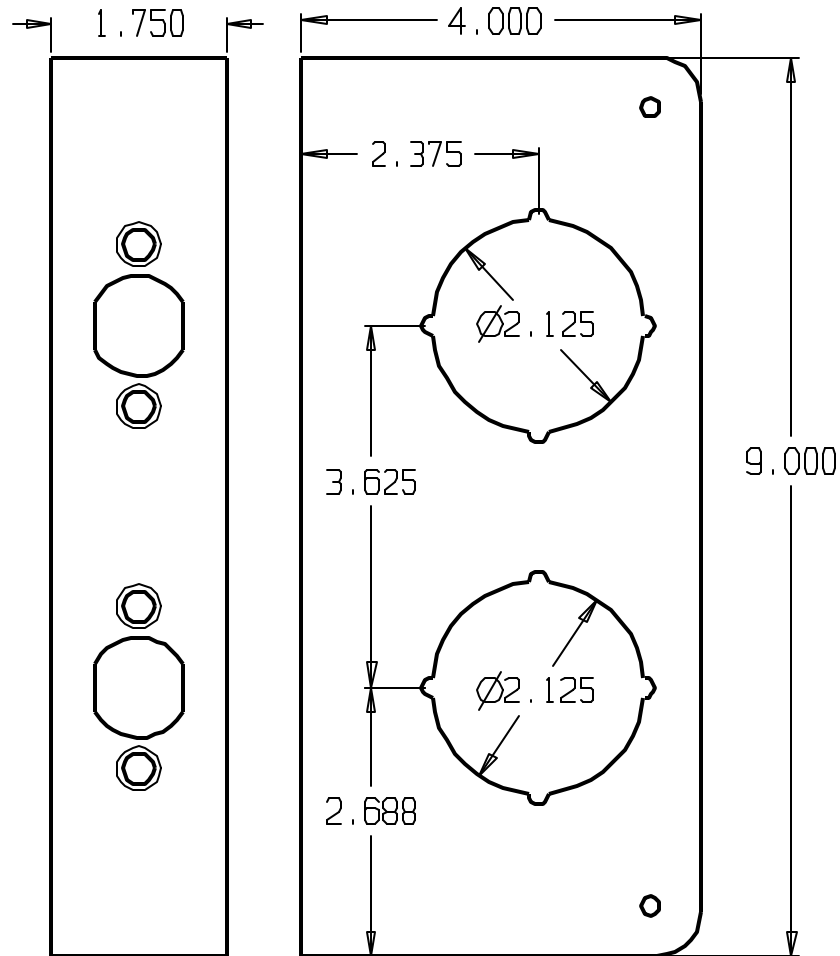

DON-JO MFG. INC.

| | | | | |
|----------|-------|--------------|----------|-------|
| DESIGNER | SIZE | DATE | PART NO. | REV |
| | A | 4/5/04 | 261-VF | |
| APPROVED | SCALE | RELEASE DATE | WEIGHT | SHEET |

| REVISIONS | | | | |
|-----------|-----|---------------------|------|----------|
| ZONE | REV | FINISHES: | DATE | APPROVED |
| | | PB, AB, BZ, 10B & S | | |

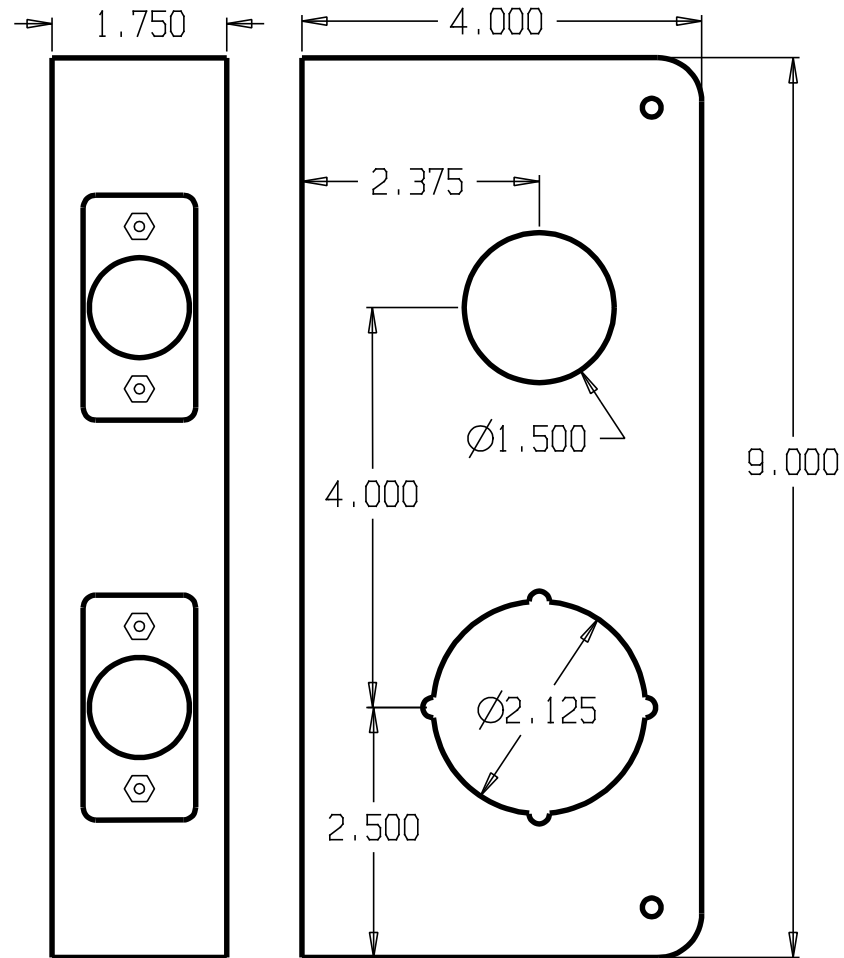

DON-JO MFG. INC.

| | | | | |
|----------|-----------|-----------------|--------------------|-------|
| DESIGNER | SIZE A | DATE: 4/5/04 | PART NO. 264-CW | REV |
| APPROVED | SCALE | RELEASE DATE | WEIGHT | SHEET |

| REVISIONS | | |
|-----------|-----|---------------|
| ZONE | REV | FINISHES: |
| | | 605, 630 & DU |
| | | GUAGE: |
| | | 22ga. .032 |

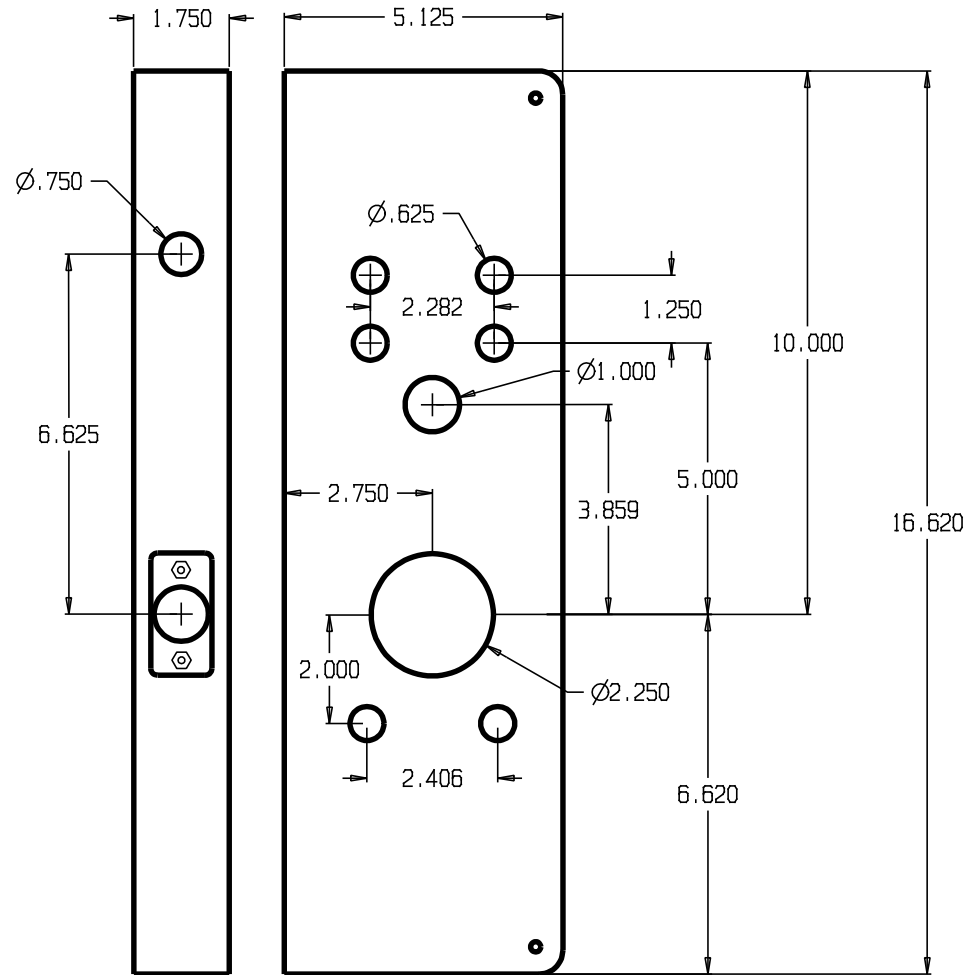

DON-JO MFG. INC.

PER SCHLAGE REV. 06/11-A

| | | | |
|----------|--------------|----------|-------|
| DESIGNER | DATE: | PART NO. | REV |
| D.R. | A 5/16/13 | 26-AD-CW | |
| SCALE | RELEASE DATE | WEIGHT | SHEET |

| REVISIONS | | |
|-----------|-----|---------------|
| ZONE | REV | FINISHES: |
| | | 605, 630 & DU |
| | | GUAGE: |
| | | 22ga. .032 |

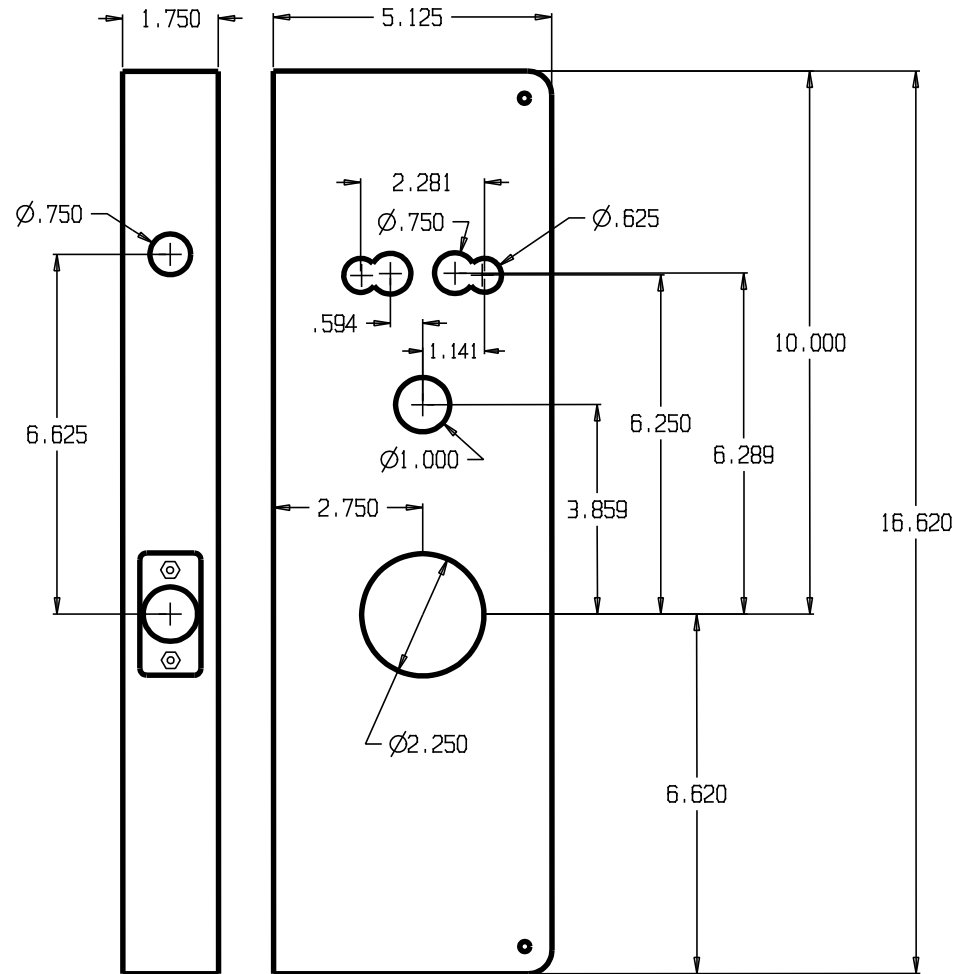

DON-JO MFG. INC.

2011 PER SCHLAGE REV. 06/11-A

| | | | |
|----------|--------------|----------|-------|
| DESIGNER | DATE: | PART NO. | REV |
| D.R. | 5/16/13 | 26-CO-CW | |
| SCALE | RELEASE DATE | WEIGHT | SHEET |

| REVISIONS | | | |
|-----------|-----|------------|------------|
| ZONE | REV | FINISHES: | GALUGE: |
| | | PB, AB & S | 22ga. .032 |

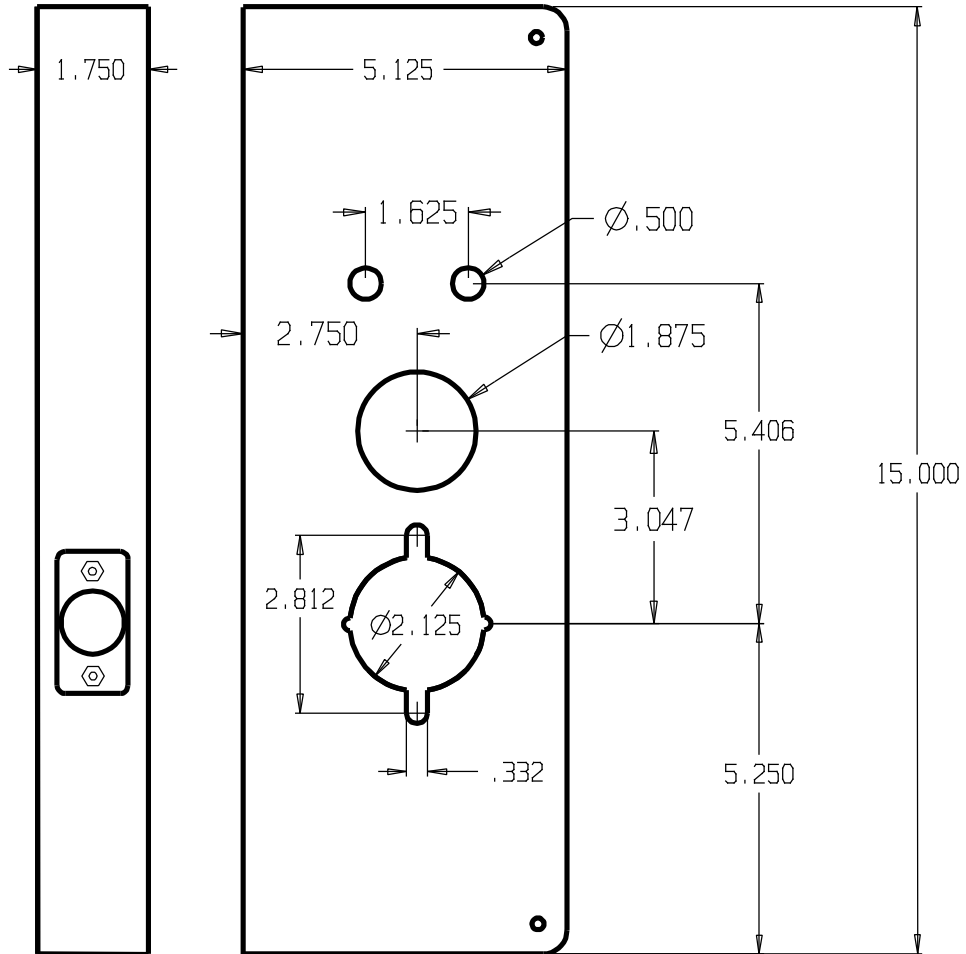

DON-JO MFG. INC.

| | | | | |
|----------|-----------|------------------|-------------------|-------|
| DESIGNER | SIZE A | DATE: 1/12/12 | PART NO. 27-CW | REV |
| APPROVED | SCALE | RELEASE DATE | WEIGHT | SHEET |

| REVISIONS | | | |
|-----------|-----|---------------|------------|
| ZONE | REV | FINISHES: | GALUGE: |
| | | 605, 609, 630 | 22ga. .032 |

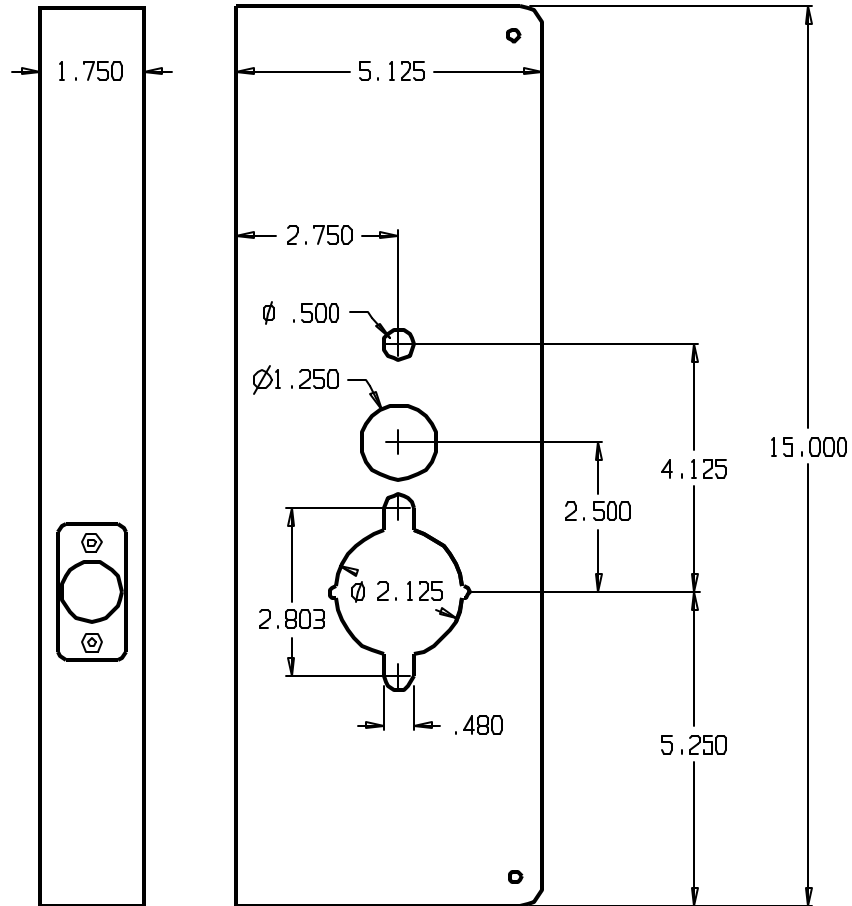

DON-JO MFG. INC.

| | | | | |
|----------|-----------|----------------|-------------------|-------|
| DESIGNER | SIZE A | DATE 2/5/10 | PART NO. 28-CW | REV |
| APPROVED | SCALE | RELEASE DATE | WEIGHT | SHEET |

| REVISIONS | | |
|-----------|-----|---------------------|
| ZONE | REV | FINISHES: |
| | | PB, AB, BZ, 10B & S |
| | | GALUGE: |
| | | 22ga. .032 |

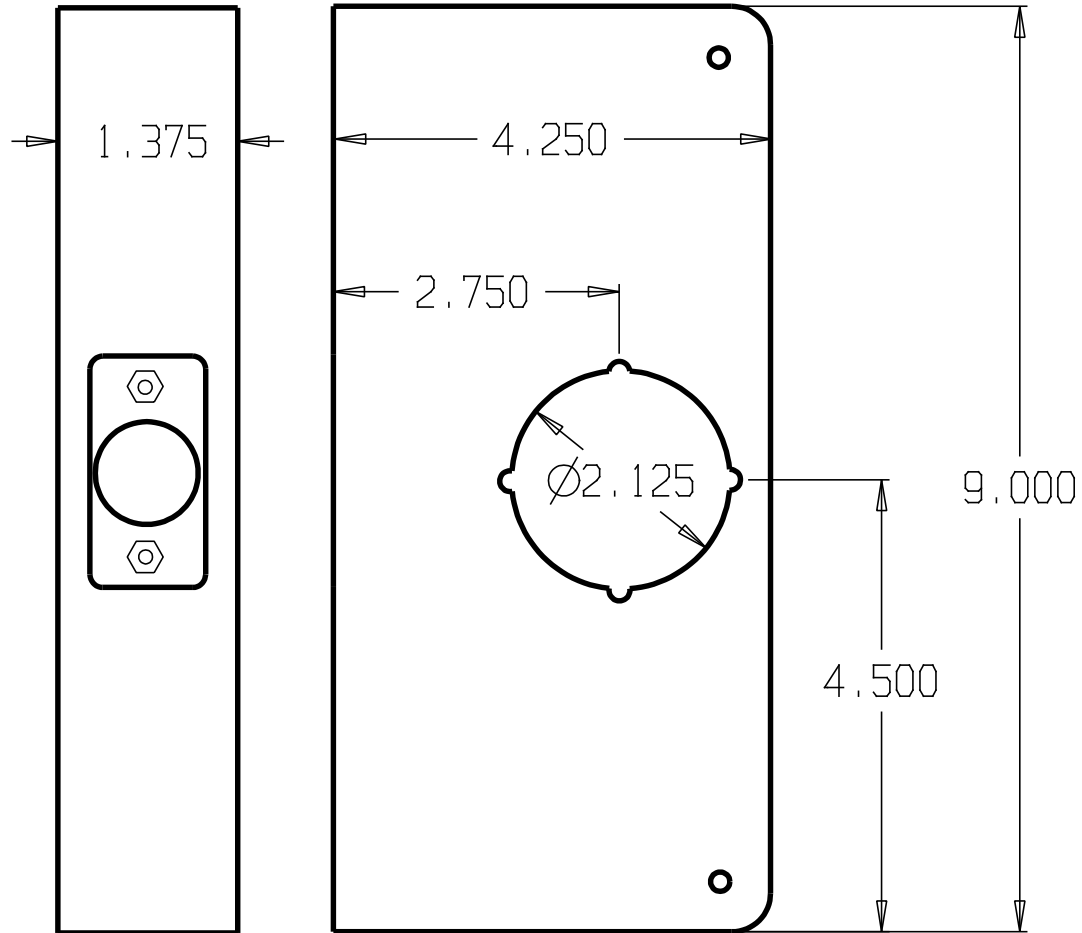

DON-JO MFG. INC.

| | |
|----------|--|
| DESIGNER | |
| APPROVED | |

| | | | |
|-------|--------------|----------|-------|
| SIZE | DATE: | PART NO. | REV |
| A | 1/1/94 | 3-CW | |
| SCALE | RELEASE DATE | WEIGHT | SHEET |

DWG NO. SH REV

REVISIONS

| ZONE | REV | FINISHES: | DATE | APPROVED |
|------|-----|---------------------|------|----------|
| | | PB, AB, BZ, 10B & S | | |

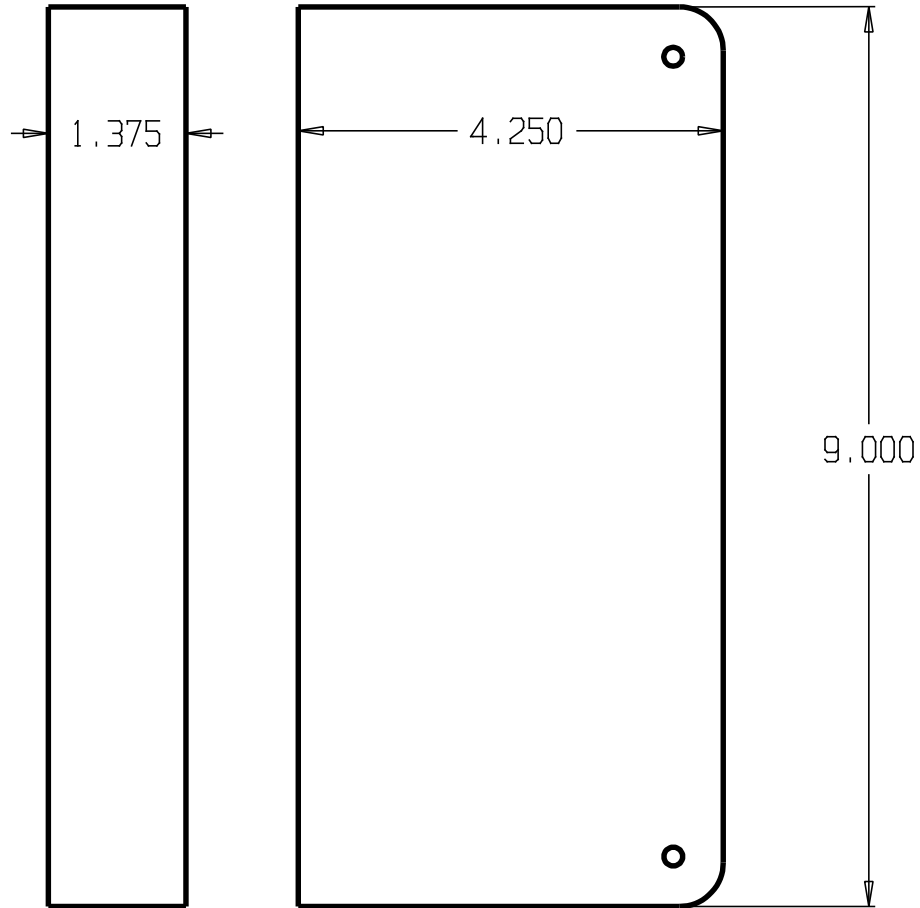

DON-JO MFG. INC.

| | | | | | | | | | |
|----------|--|-------|---|--------------|---------|----------|-------|-------|--|
| DESIGNER | | SIZE | A | DATE: | 4/19/04 | PART NO. | 30-CW | REV | |
| APPROVED | | SCALE | | RELEASE DATE | | WEIGHT | | SHEET | |

| REVISIONS | | | |
|-----------|-----|----------------|------------|
| ZONE | REV | FINISHES: | GALUGE: |
| | | PB, AB, BZ & S | 22ga. .032 |

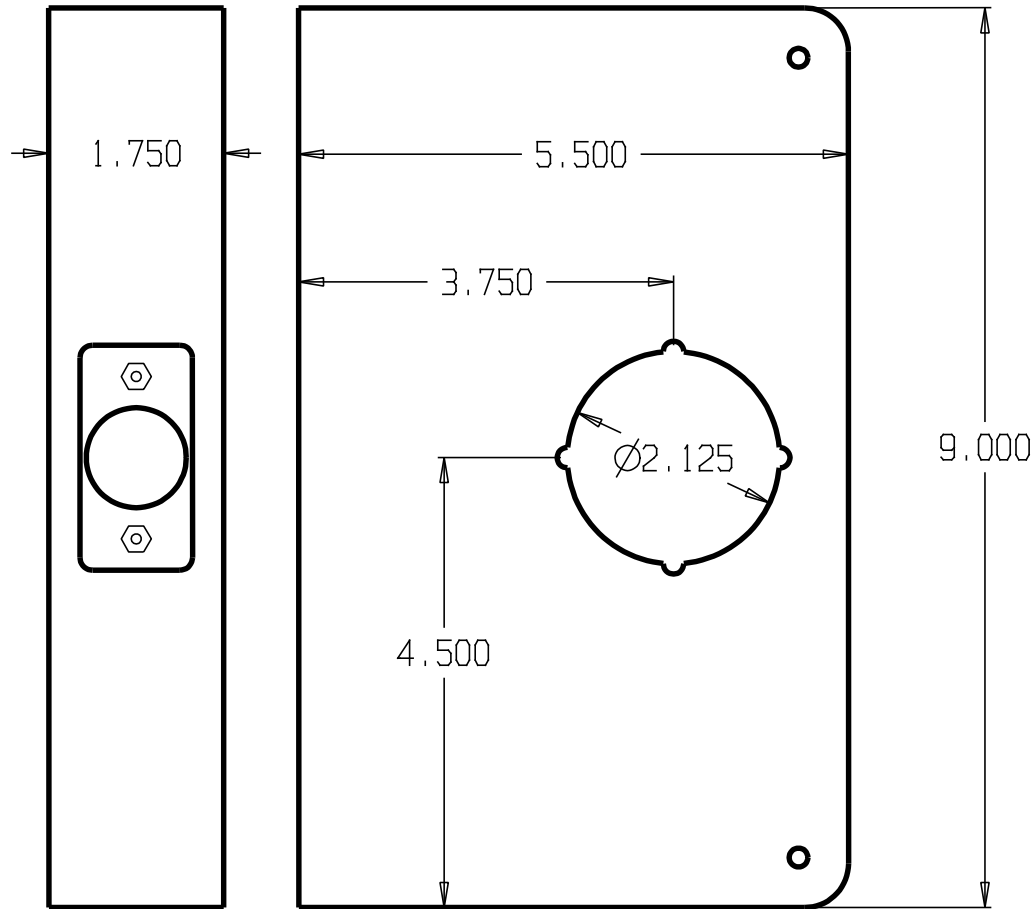

DON-JO MFG. INC.

| | | | | |
|----------|-------|--------------|----------|-------|
| DESIGNER | SIZE | DATE: | PART NO. | REV |
| | A | 4/27/04 | 33-CW | |
| APPROVED | SCALE | RELEASE DATE | WEIGHT | SHEET |
| | | | | |

| REVISIONS | | | |
|-----------|-----|----------------|------------|
| ZONE | REV | FINISHES: | GUAGE: |
| | | PB, AB, BZ & S | 22ga. .032 |

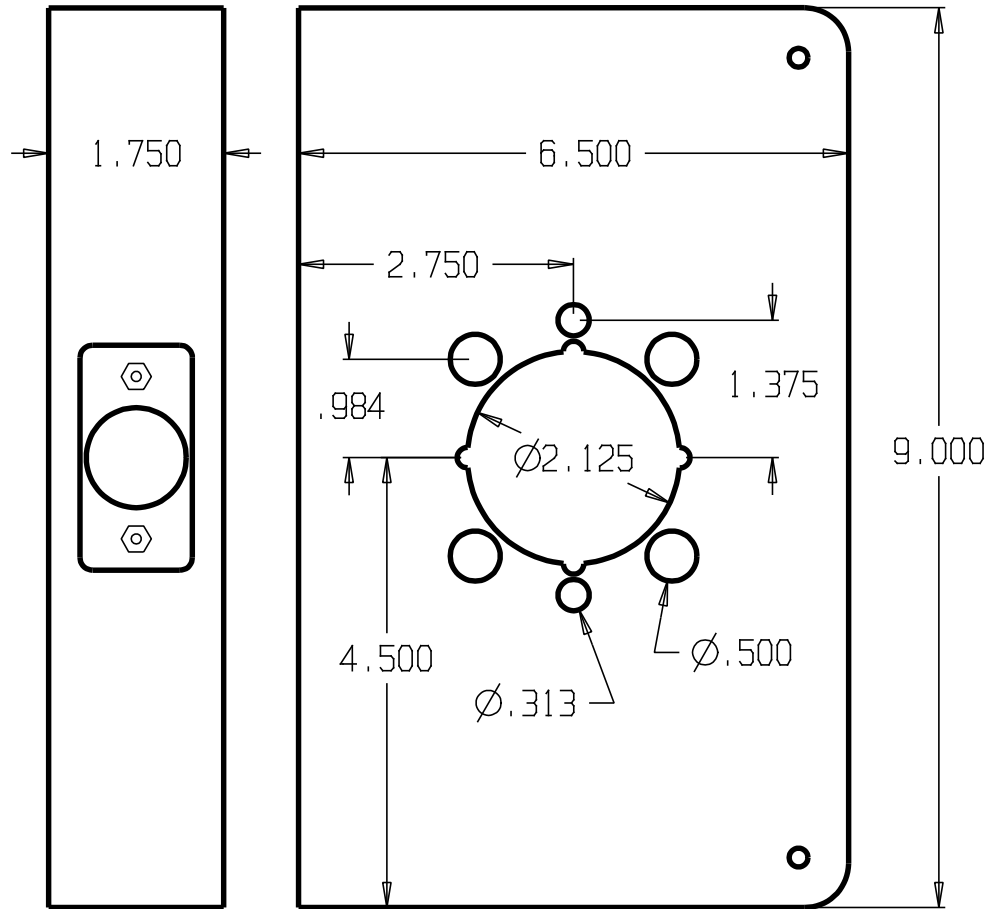

DON-JO MFG. INC.

| | | | | |
|----------|-------|--------------|----------|-------|
| DESIGNER | SIZE | DATE: | PART NO. | REV |
| | A | 4/27/04 | 33A-2-CW | |
| APPROVED | SCALE | RELEASE DATE | WEIGHT | SHEET |
| | | | | |

| REVISIONS | | |
|-----------|-----|----------------|
| ZONE | REV | FINISHES: |
| | | PB, AB, BZ & S |
| | | GALUGE: |
| | | 22ga. .032 |

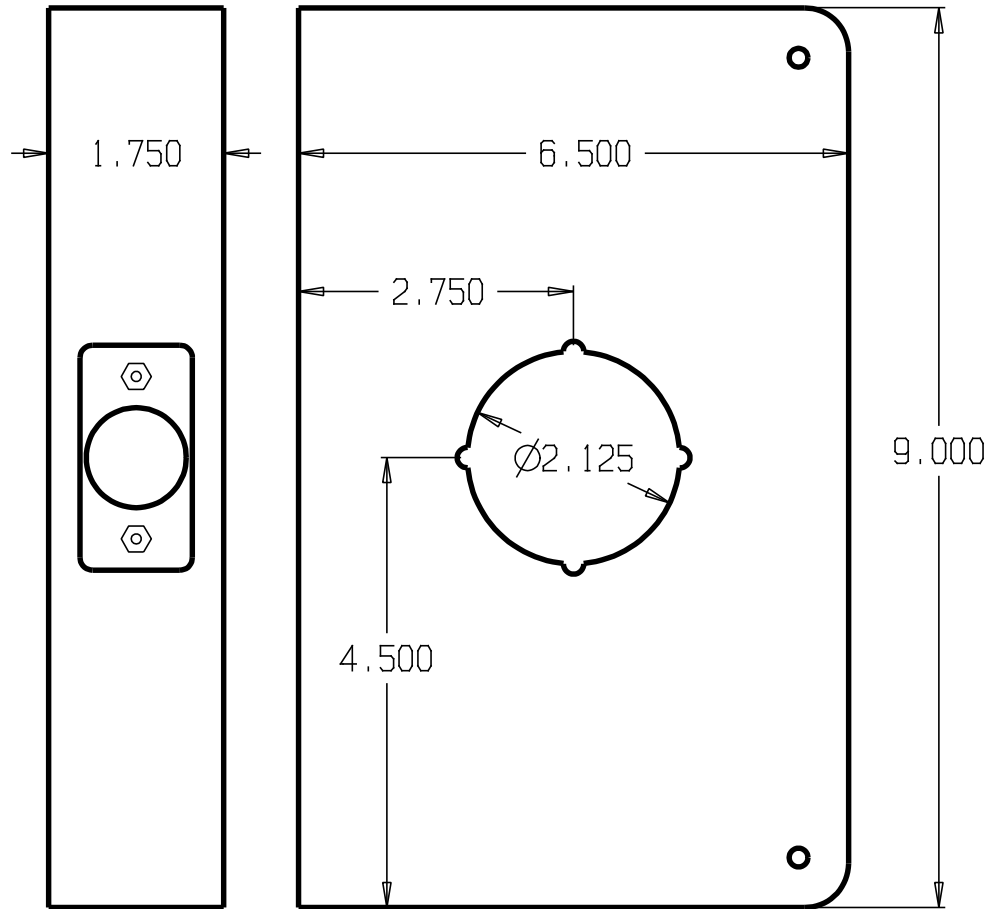

DON-JO MFG. INC.

| | | | | |
|----------|-------|--------------|----------|-------|
| DESIGNER | SIZE | DATE: | PART NO. | REV |
| | A | 4/27/04 | 33A-CW | |
| APPROVED | SCALE | RELEASE DATE | WEIGHT | SHEET |
| | | | | |

| REVISIONS | | | |
|-----------|-----|------------|------------|
| ZONE | REV | FINISHES: | GALUGE: |
| | | PB, AB & S | 22ga. .032 |

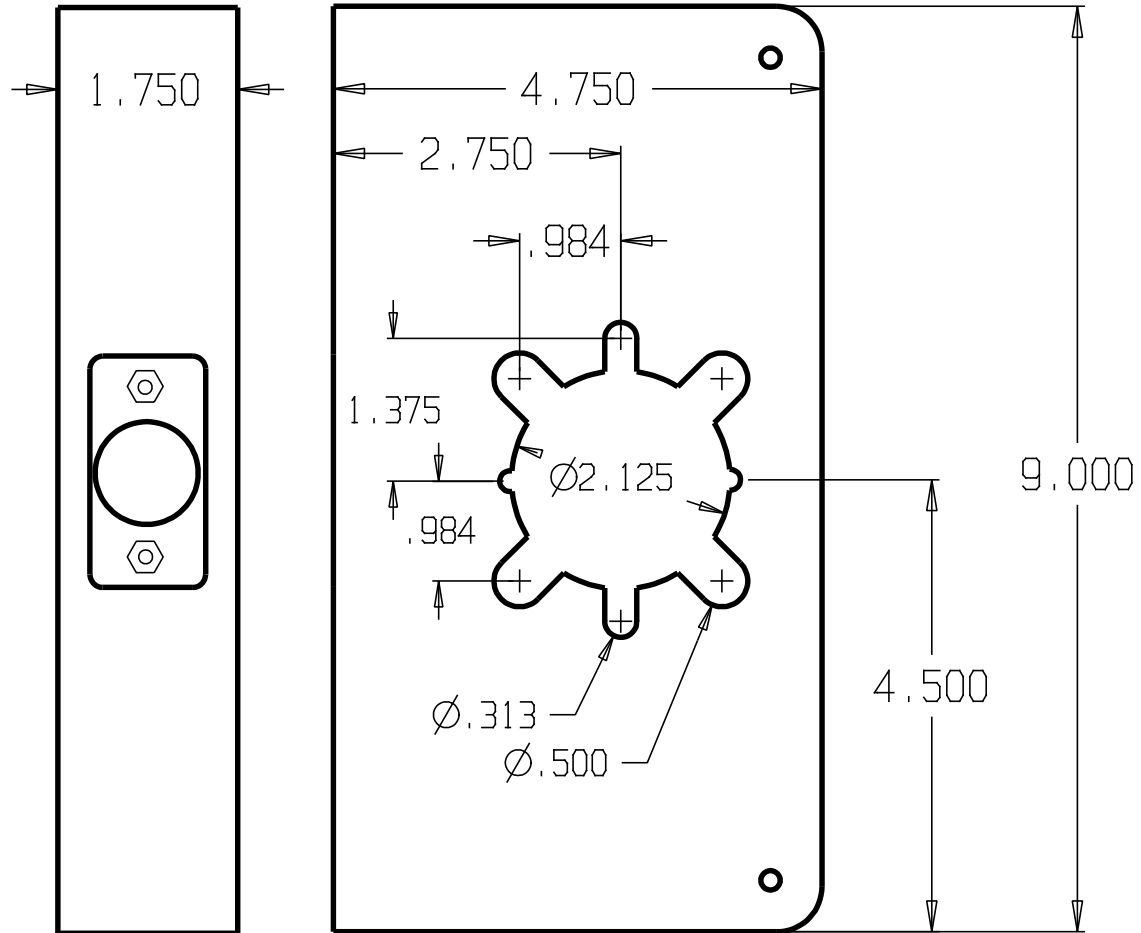

DON-JO MFG. INC.

DESIGNER
APPROVED

| | | | |
|-----------|-----------------|--------------------|-------|
| SIZE A | DATE: 1/1/94 | PART NO. 4-2-CW | REV |
| SCALE | RELEASE DATE | WEIGHT | SHEET |

| REVISIONS | | |
|-----------|-----|---------------------|
| ZONE | REV | FINISHES: |
| | | PB, AB, BZ, 10B & S |
| | | GALUGE: |
| | | 22GA. .032 |

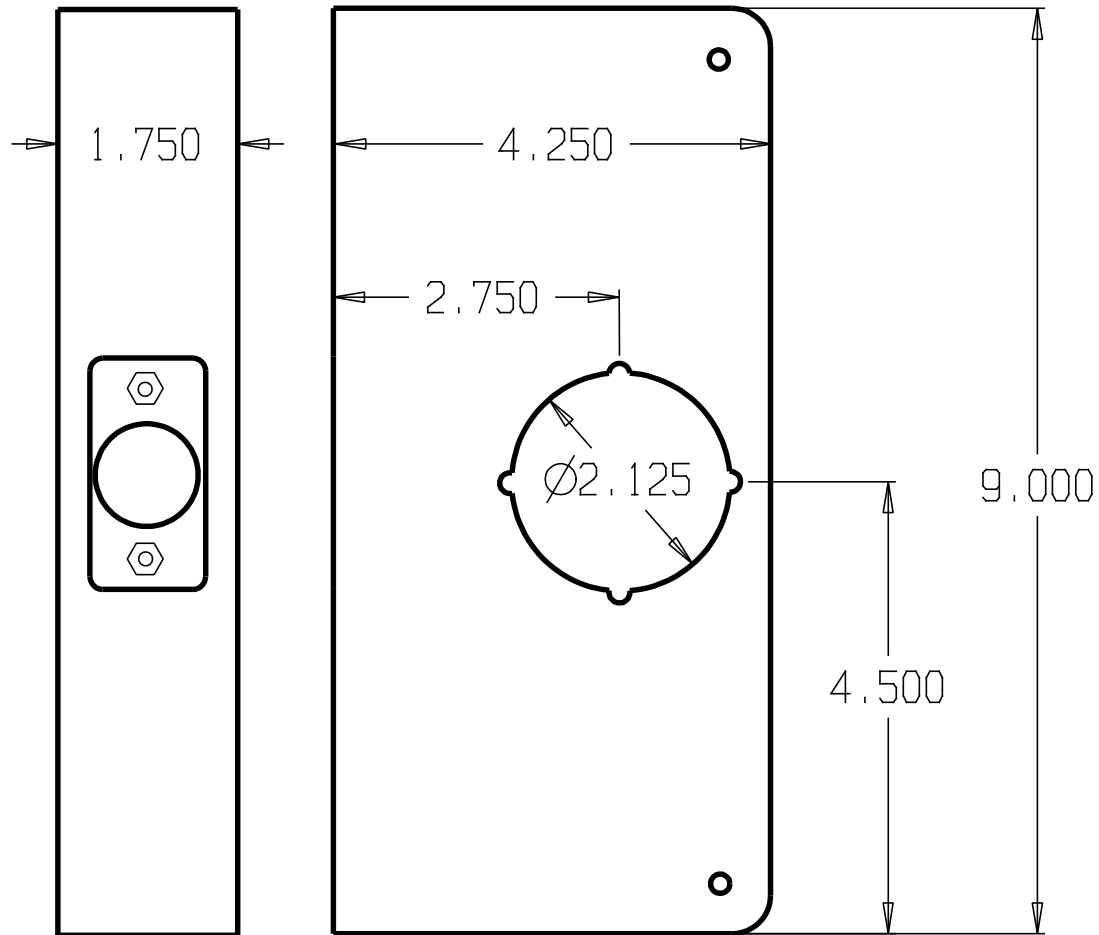

DON-JO MFG. INC.

DESIGNER
APPROVED

| | | | |
|-----------|-----------------|------------------|-------|
| SIZE A | DATE: 1/1/94 | PART NO. 4-CW | REV |
| SCALE | RELEASE DATE | WEIGHT | SHEET |

| REVISIONS | | |
|-----------|-----|---------------------|
| ZONE | REV | FINISHES: |
| | | PB, AB, BZ, 10B & S |
| | | GALIGE: |
| | | 22ga. .032 |

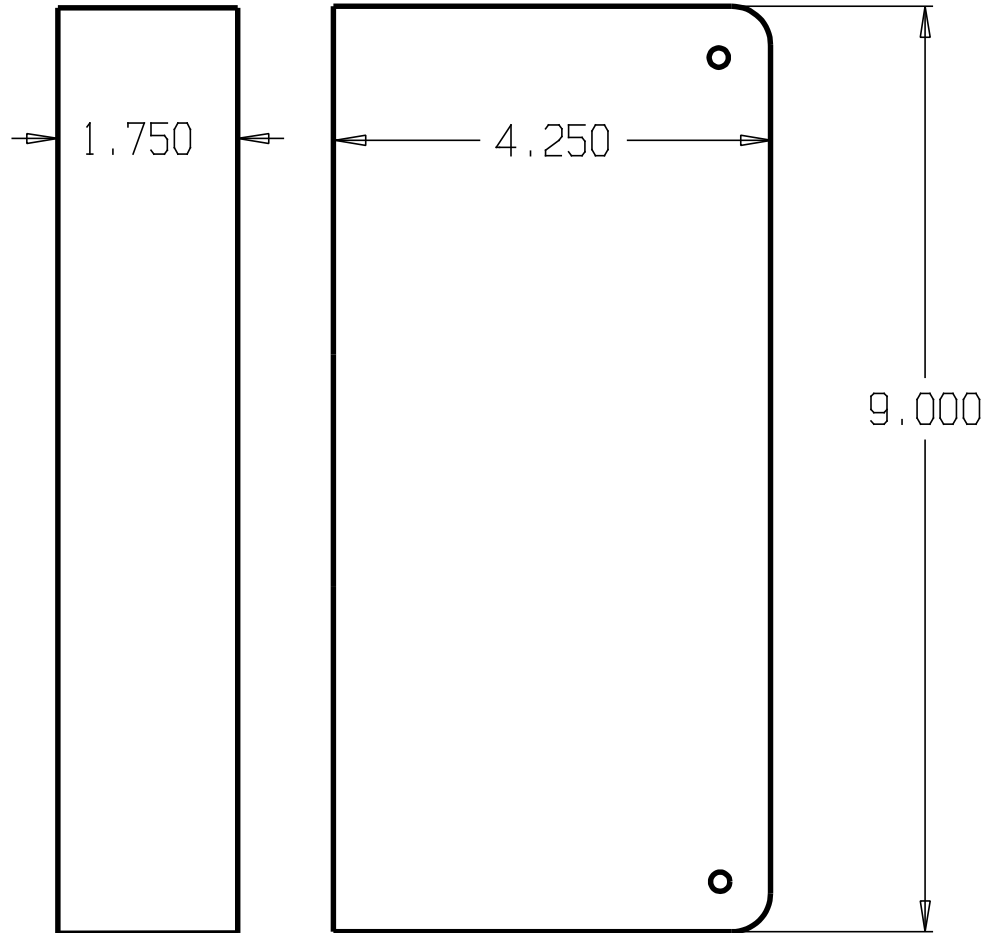

DON-JO MFG. INC.

| | |
|----------|--|
| DESIGNER | |
| APPROVED | |

| | | | |
|-------|--------------|----------|-------|
| SIZE | DATE: | PART NO. | REV |
| A | 1/1/94 | 40-CW | |
| SCALE | RELEASE DATE | WEIGHT | SHEET |
| | | | |

| REVISIONS | | | |
|-----------|-----|------------|------------|
| ZONE | REV | FINISHES: | GAUGE: |
| | | PB, AB & S | 22ga. .032 |

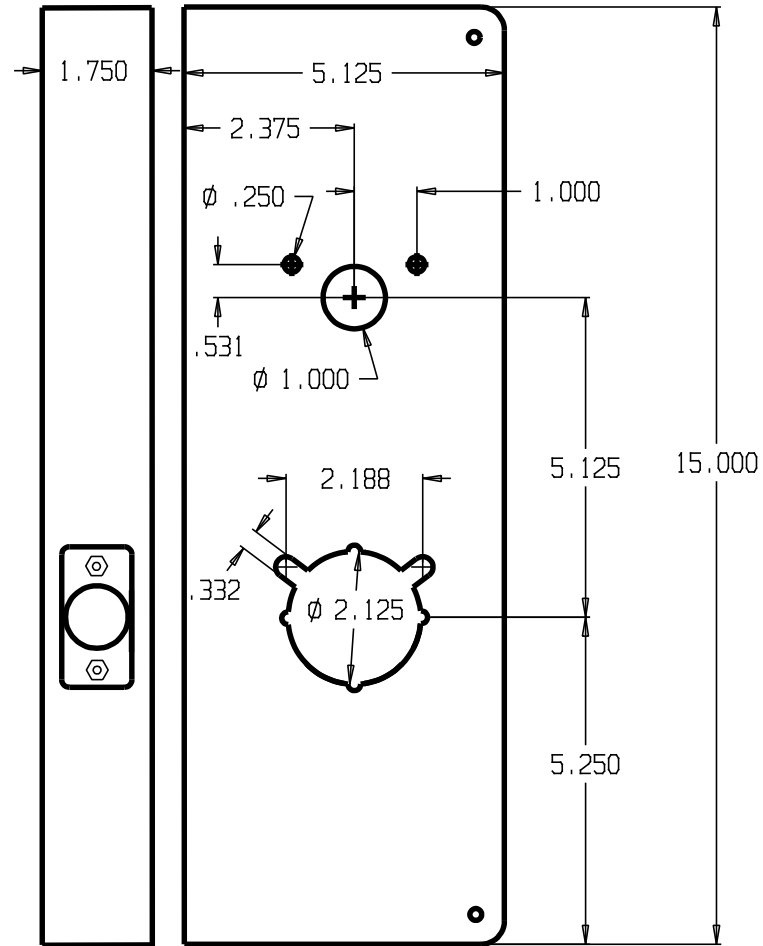

DON-JO MFG. INC.

| | | | | |
|----------|-------|--------------|-----------|-------|
| DESIGNER | SIZE | DATE: | PART NO. | REV |
| | A | 5/6/04 | 4000-2-CW | |
| APPROVED | SCALE | RELEASE DATE | WEIGHT | SHEET |
| | | | | |

| REVISIONS | | | |
|-----------|-----|------------|------------|
| ZONE | REV | FINISHES: | GAUGE: |
| | | PB, AB & S | 22ga. .032 |

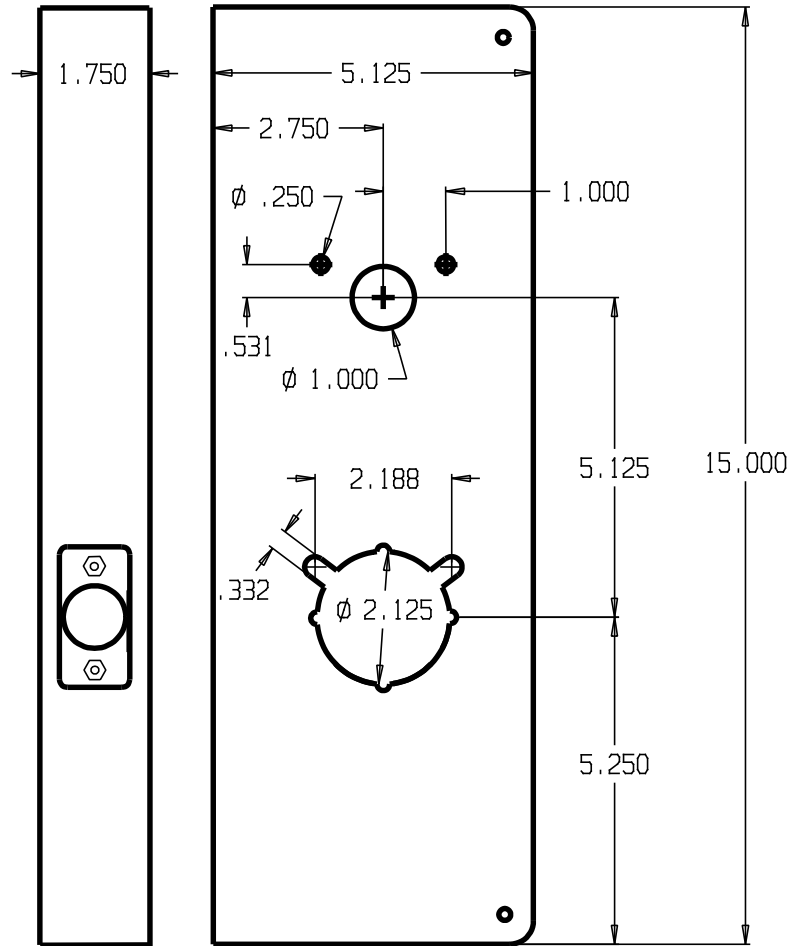

DON-JO MFG. INC.

| | | | | |
|----------|-------|--------------|-----------|-------|
| DESIGNER | SIZE | DATE: | PART NO. | REV |
| | A | 5/6/04 | 4000-4-CW | |
| APPROVED | SCALE | RELEASE DATE | WEIGHT | SHEET |
| | | | | |

| REVISIONS | | |
|-----------|-----|---------------------|
| ZONE | REV | FINISHES: |
| | | PB, AB, BZ, 10B & S |
| | | GUAGE: |
| | | 22GA. .032 |

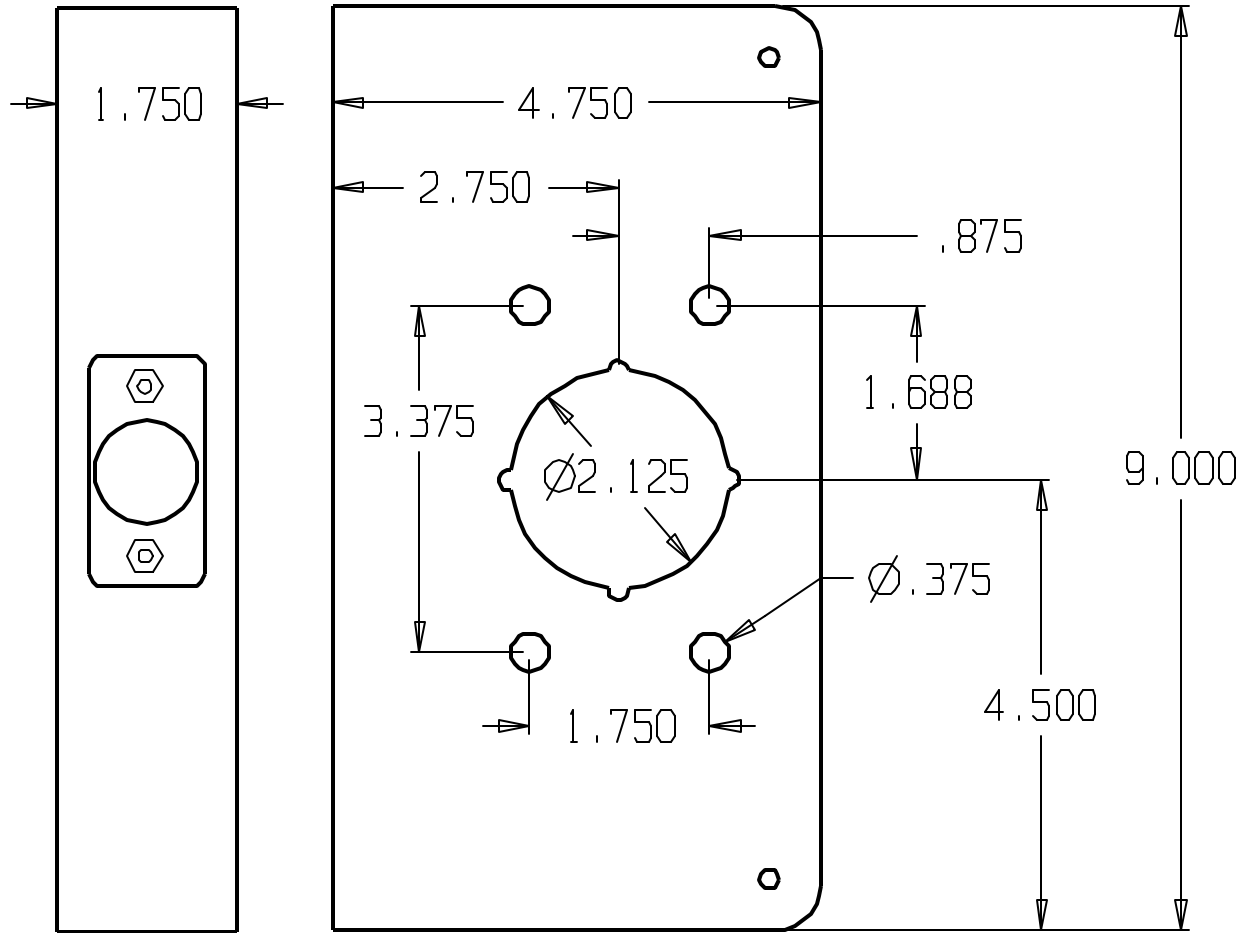

DON-JO MFG. INC.

DESIGNER
APPROVED

| | | | |
|-----------|-----------------|---------------------|-------|
| SIZE A | DATE: 2/3/10 | PART NO. 4500-CW | REV |
| SCALE | RELEASE DATE | WEIGHT | SHEET |

| REVISIONS | | |
|-----------|-----|----------------|
| ZONE | REV | FINISHES: |
| | | PB, AB, BZ & S |
| | | GAUGE: |
| | | 22ga. .032 |

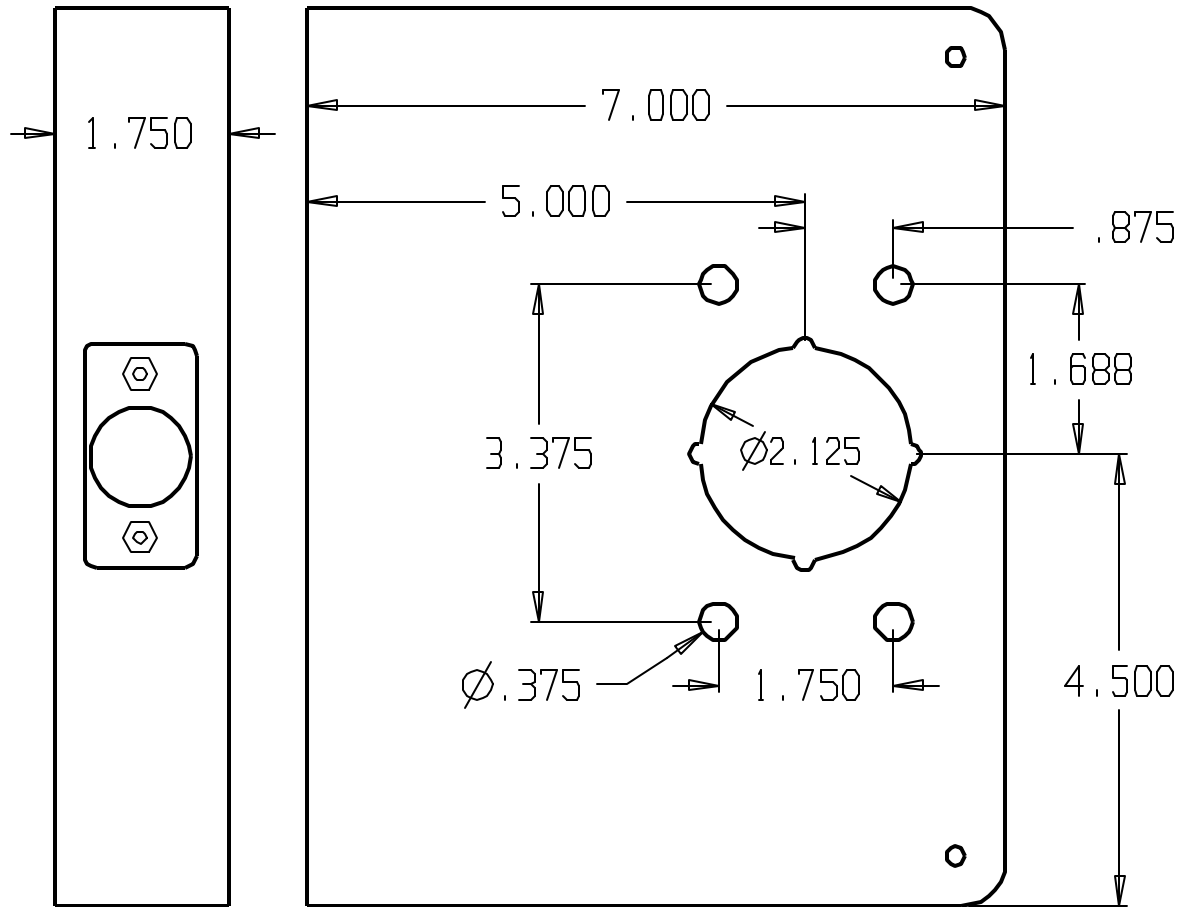

DON-JO MFG. INC.

| | | | | |
|----------|-------|--------------|----------|-------|
| DESIGNER | SIZE | DATE | PART NO. | REV |
| | A | 2/10/10 | 4550-CW | |
| APPROVED | SCALE | RELEASE DATE | WEIGHT | SHEET |
| | | | | |

| REVISIONS | | | |
|-----------|-----|---------------------|----------|
| ZONE | REV | FINISHES: | DATE |
| | | PB, AB, BZ, 10B & S | |
| | | DATE | APPROVED |
| | | | |

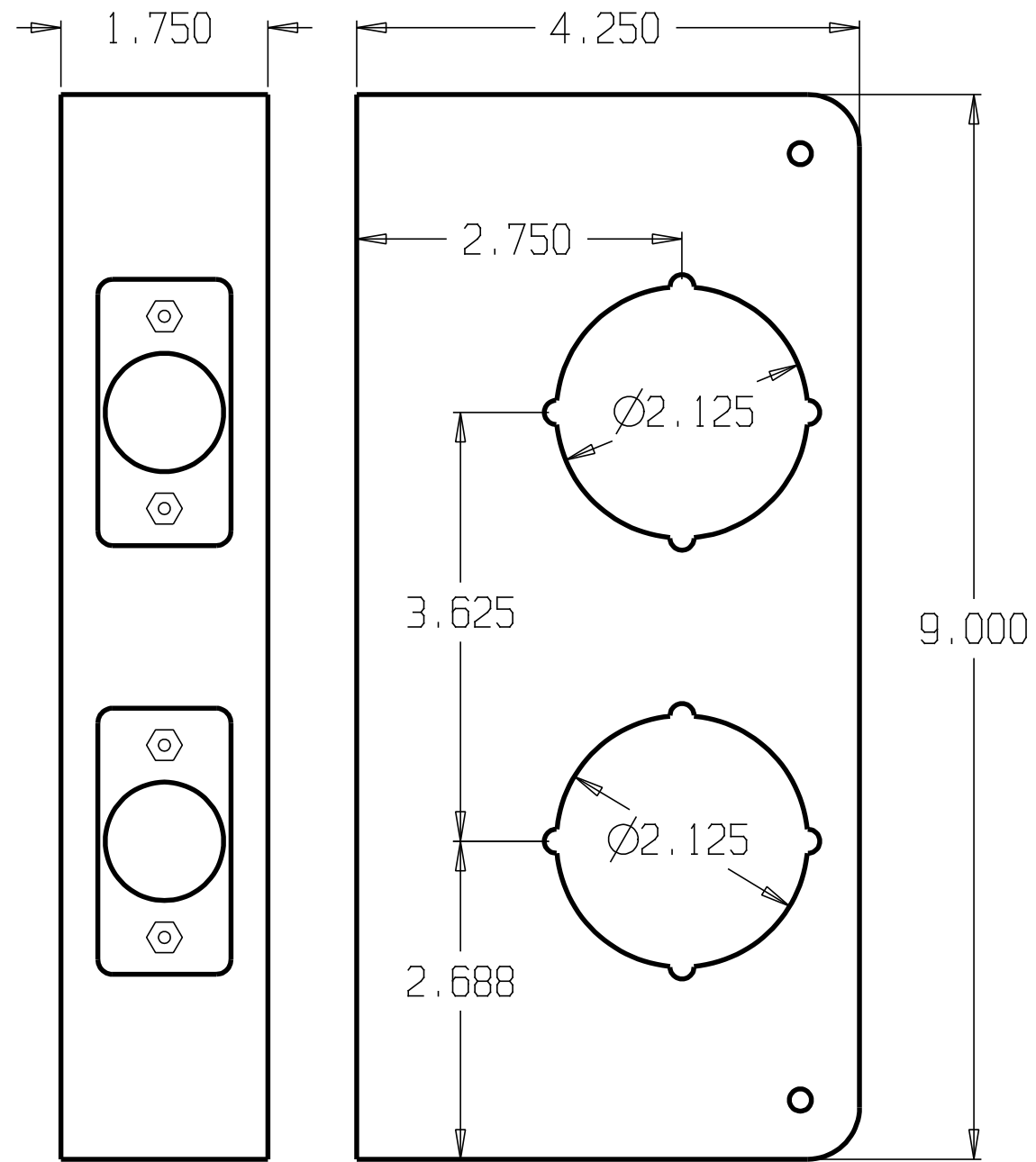

DON-JO MFG. INC.

| | | | | |
|----------|---------|---------------|-----------------|-------|
| DESIGNER | SIZE: A | DATE: 4/28/04 | PART NO. 481-CW | REV |
| APPROVED | SCALE | RELEASE DATE | WEIGHT | SHEET |

| REVISIONS | | | |
|-----------|-----|---------------------|------|
| ZONE | REV | FINISHES: | DATE |
| | | PB, AB, BZ, 10B & S | |
| | | APPROVED | |

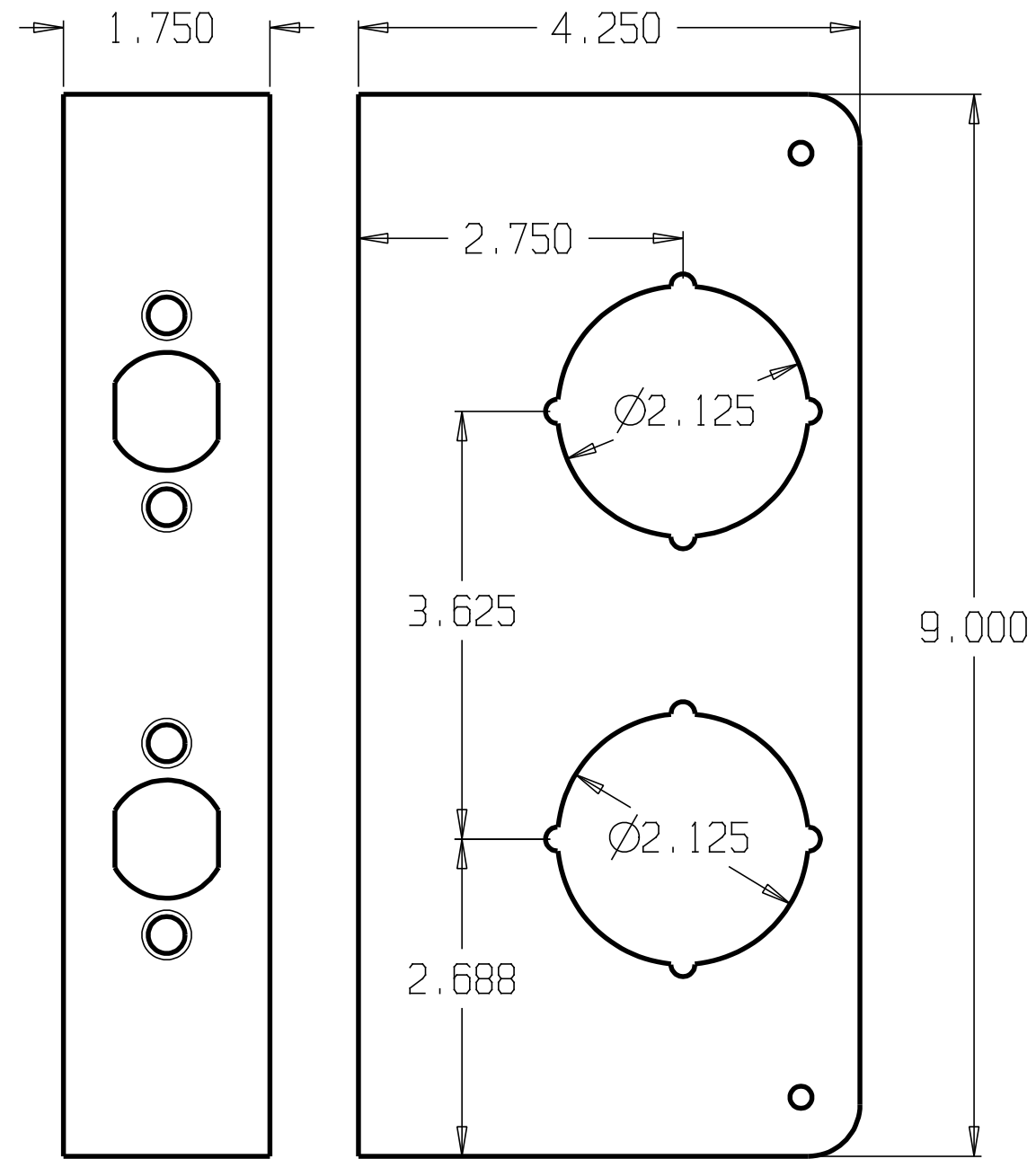

DON-JO MFG. INC.

| | | | | |
|----------|-------|--------------|----------|-------|
| DESIGNER | SIZE | DATE: | PART NO. | REV |
| | A | 4/28/04 | 481-VF | |
| APPROVED | SCALE | RELEASE DATE | WEIGHT | SHEET |
| | | | | |

| REVISIONS | | | | |
|-----------|-----|---------------------|------|----------|
| ZONE | REV | FINISHES: | DATE | APPROVED |
| | | PB, AB, BZ, 10B & S | | |

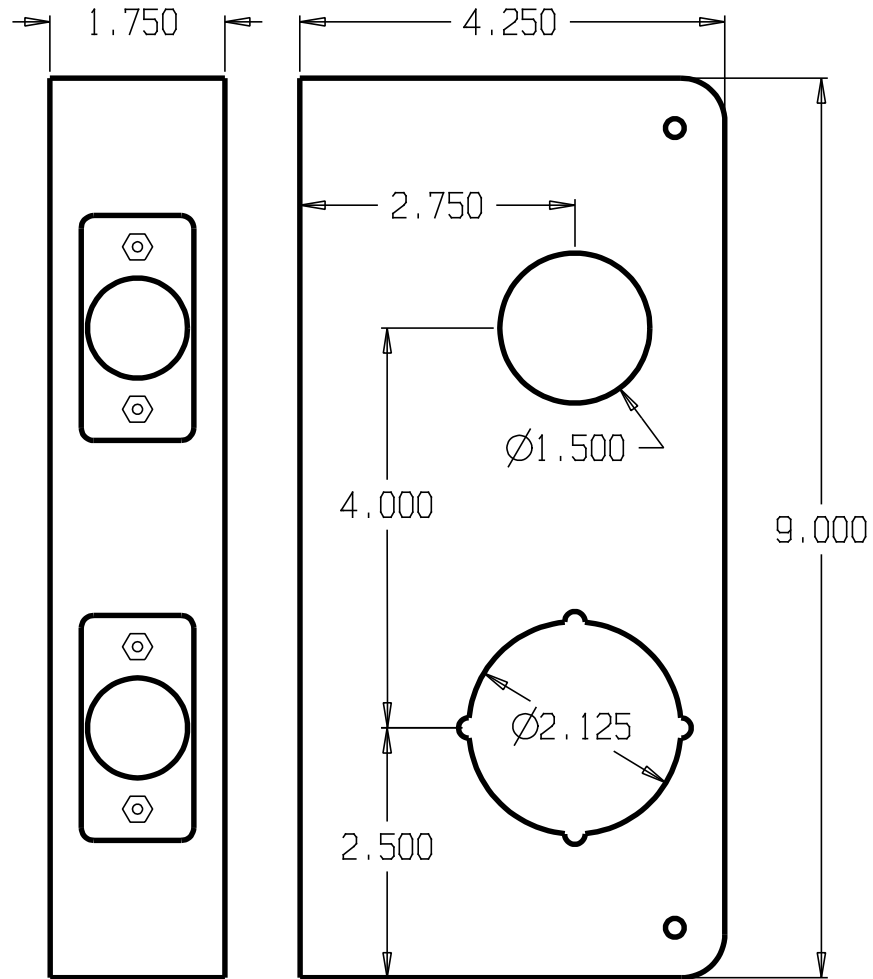

DON-JO MFG. INC.

| | | | | |
|----------|---------|---------------|-----------------|-------|
| DESIGNER | SIZE: A | DATE: 4/28/04 | PART NO. 484-CW | REV |
| APPROVED | SCALE | RELEASE DATE | WEIGHT | SHEET |

| REVISIONS | | | |
|-----------|-----|-----------|----------|
| ZONE | REV | FINISHES: | DATE |
| | | PB & S | |
| | | | APPROVED |

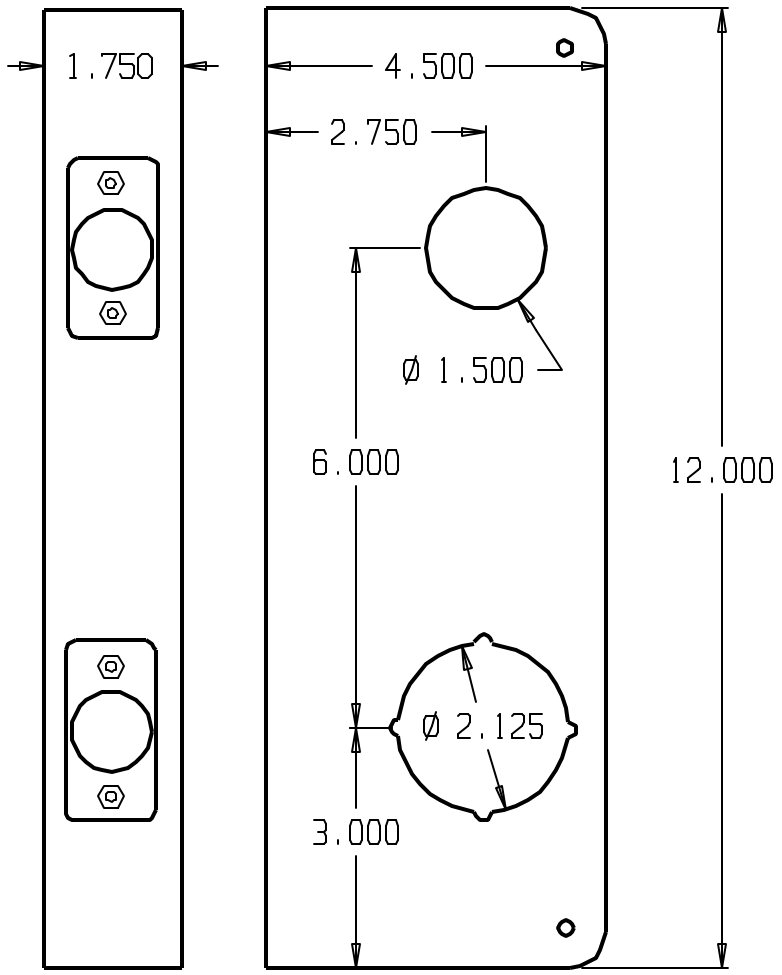

DON-JO MFG. INC.

| | | | | |
|----------|-------|--------------|----------|-------|
| DESIGNER | SIZE | DATE | PART NO. | REV |
| | A | 4/28/04 | 486-CW | |
| APPROVED | SCALE | RELEASE DATE | WEIGHT | SHEET |

| REVISIONS | | | | |
|-----------|-----|---------------------|------|----------|
| ZONE | REV | FINISHES: | DATE | APPROVED |
| | | PB, AB, BZ, 10B & S | | |

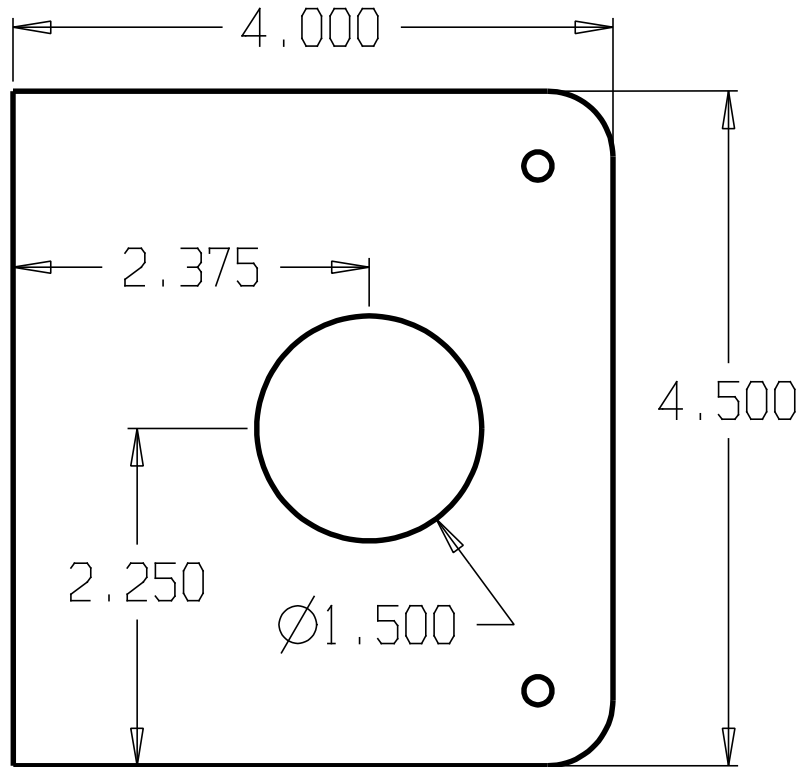
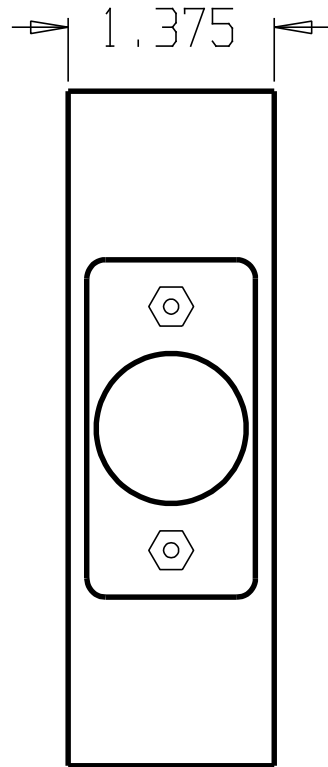

DON-JO MFG. INC.

| | | | | |
|----------|-------|--------------|----------|-------|
| DESIGNER | SIZE | DATE: | PART NO. | REV |
| | A | 4/28/04 | 5-CW | |
| APPROVED | SCALE | RELEASE DATE | WEIGHT | SHEET |

| REVISIONS | | | |
|-----------|-----|-----------|------------|
| ZONE | REV | FINISHES: | GAUGE: |
| | | PB & S | 22ga. .032 |

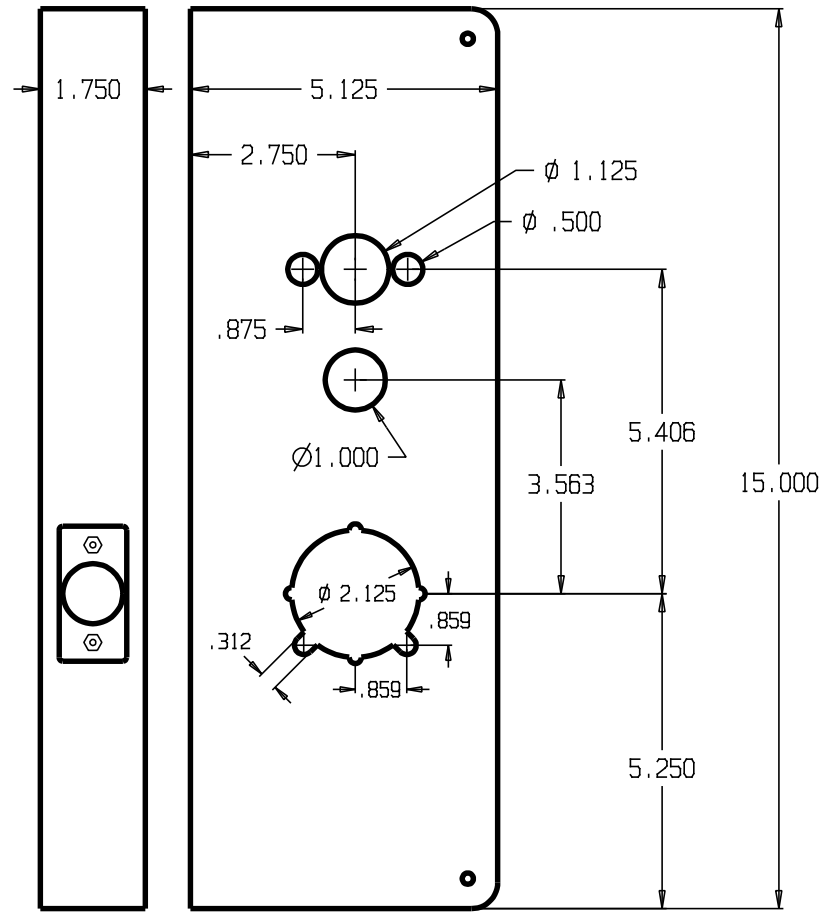

| | | | | | |
|------------------|--|-------|--------------|----------|-------|
| DON-JO MFG. INC. | | SIZE | DATE: | PART NO. | REV |
| DESIGNER | | A | 4/7/05 | 5000-CW | |
| APPROVED | | SCALE | RELEASE DATE | WEIGHT | SHEET |

| REVISIONS | | | |
|-----------|-----|------------|------------|
| ZONE | REV | FINISHES: | GUAGE: |
| | | PB, BZ & S | 22ga. .032 |

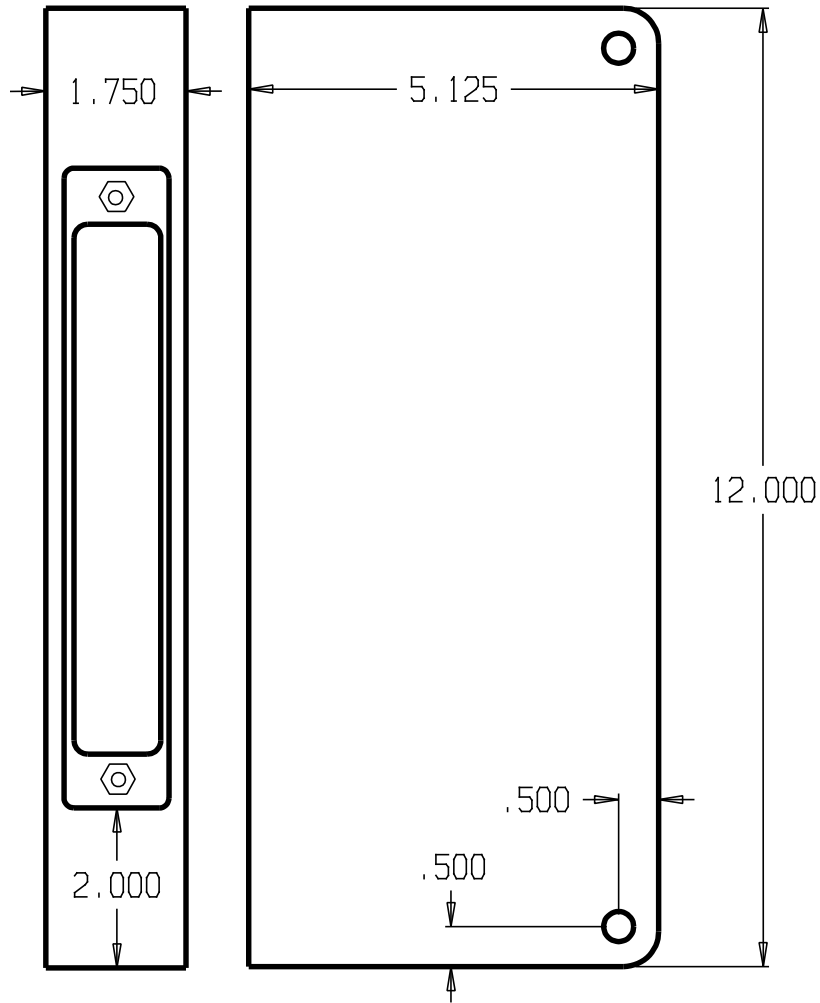

DON-JO MFG. INC.

DESIGNER
APPROVED

| | |
|-----------|------------------|
| SIZE A | DATE: 4/28/04 |
| SCALE | RELEASE DATE |

| | |
|--------------------|-------|
| PART NO. 504-CW | REV |
| WEIGHT | SHEET |

| REVISIONS | | | | |
|-----------|-----|-----------|------|----------|
| ZONE | REV | FINISHES: | DATE | APPROVED |
| | | S | | |

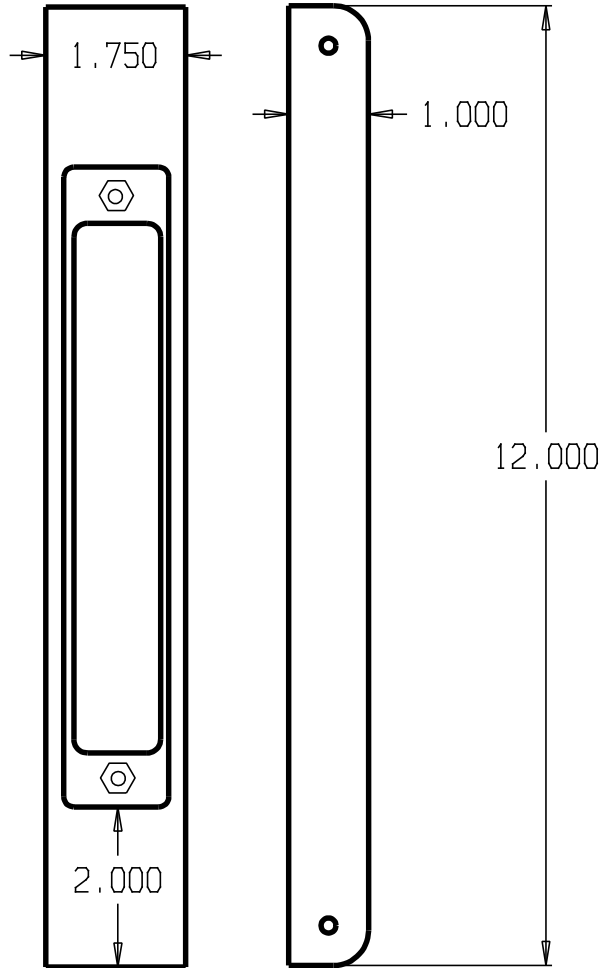

| | | | | |
|------------------|-----------|------------------|--------------------|-------|
| DON-JO MFG. INC. | | | | |
| DESIGNER | SIZE A | DATE: 4/28/04 | PART NO. 504-FE | REV |
| APPROVED | SCALE | RELEASE DATE | WEIGHT | SHEET |

| REVISIONS | | | |
|-----------|-----|---------------------|------------|
| ZONE | REV | FINISHES: | GAUGE: |
| | | 605, 630, DURO COAT | 22ga. .032 |

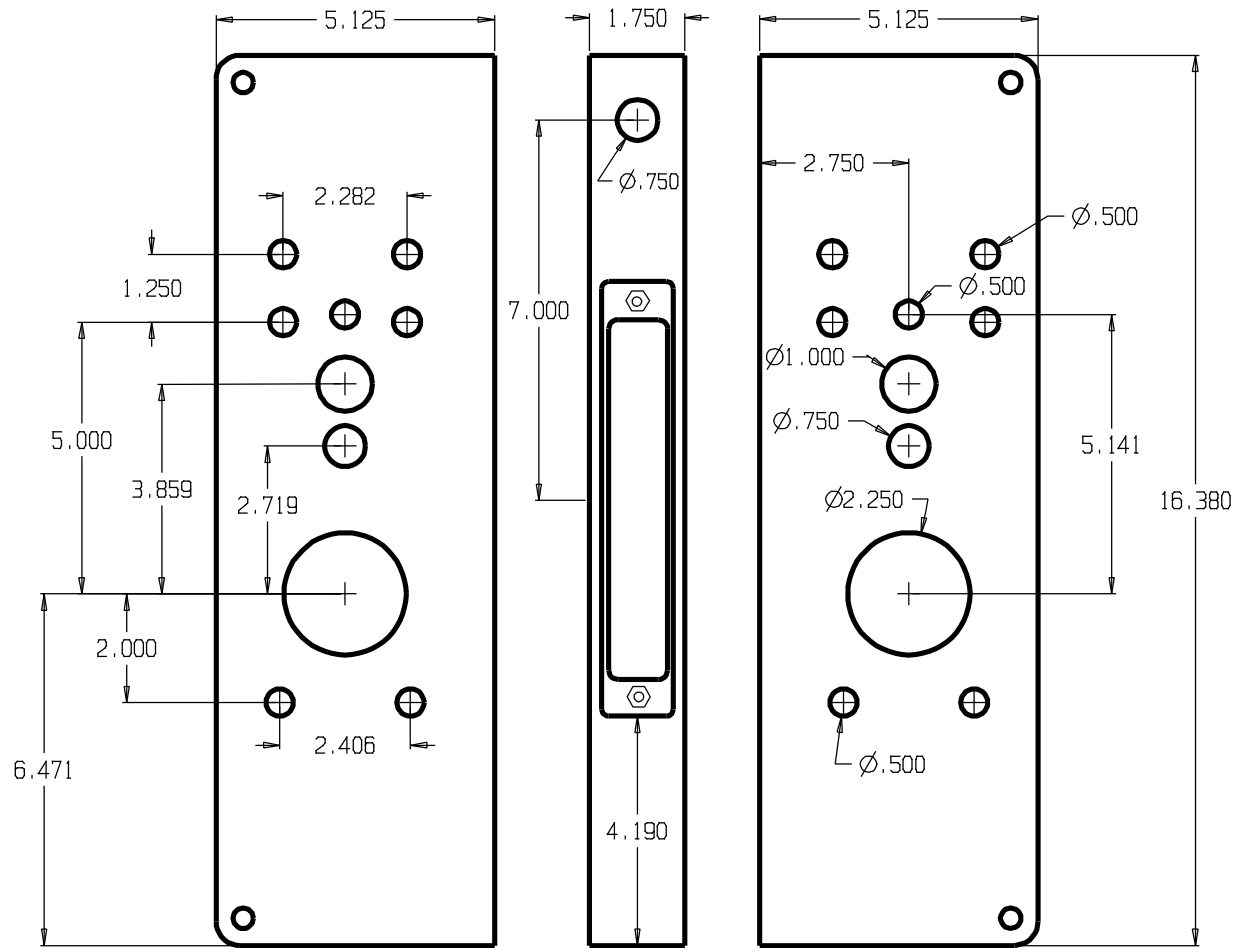

DON-JO MFG. INC.

DESIGNER: D.R.

PER SCHLAGE REV. 6/11-A

| | | | |
|---------|--------------|-------------------|-------|
| SIZE: A | DATE: 2/2/12 | PART NO. 504AD-CW | REV |
| SCALE | RELEASE DATE | WEIGHT | SHEET |

| REVISIONS | | | | |
|-----------|-----|---------------------|------|----------|
| ZONE | REV | FINISHES: | DATE | APPROVED |
| | | PB, AB, BZ, 10B & S | | |

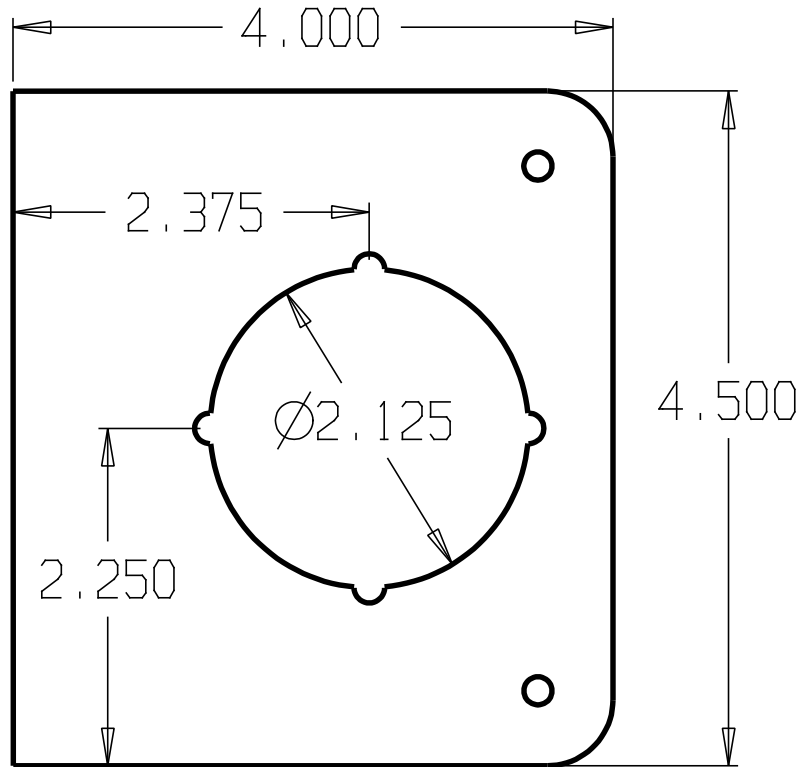
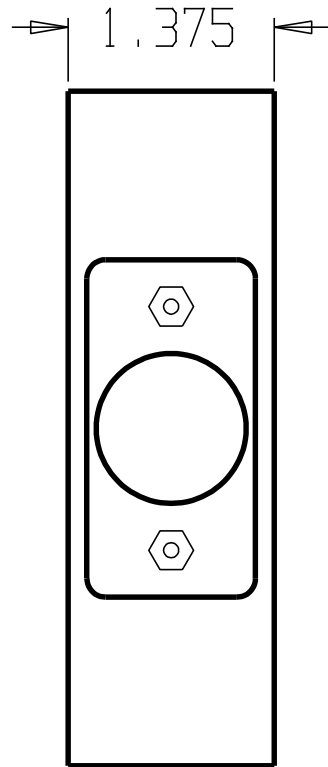

| | | | | | |
|------------------|--|-------|--------------|----------|-------|
| DON-JO MFG. INC. | | SIZE | DATE: | PART NO. | REV |
| DESIGNER | | A | 4/28/04 | 51-CW | |
| APPROVED | | SCALE | RELEASE DATE | WEIGHT | SHEET |

| REVISIONS | | | |
|-----------|-----|-----------|------------|
| ZONE | REV | FINISHES: | GALUGE: |
| | | 605,630 | 22ga. .032 |

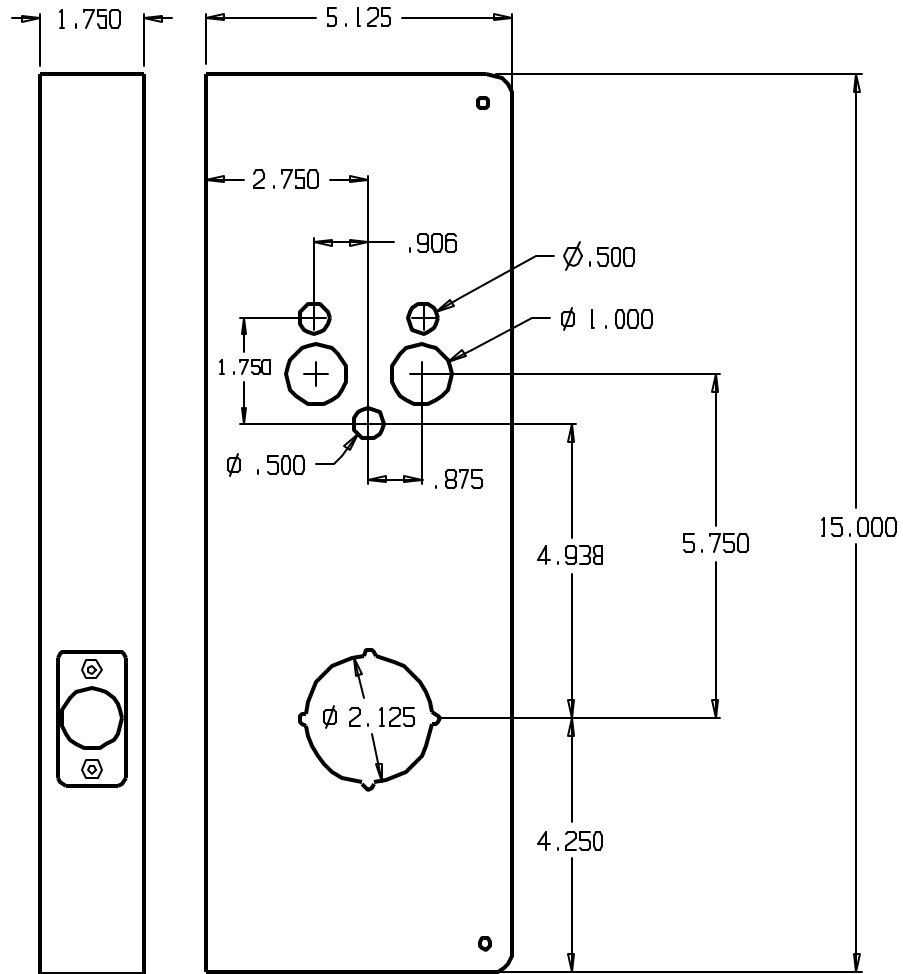

DON-JO MFG. INC.

| | | | | |
|----------|-----------|-----------------|---------------------|-------|
| DESIGNER | SIZE A | DATE 7/19/04 | PART NO. 5100-CW | REV |
| APPROVED | SCALE | RELEASE DATE | WEIGHT | SHEET |

| REVISIONS | | | |
|-----------|-----|------------|------------|
| ZONE | REV | FINISHES: | GALUGE: |
| | | PB, BZ & S | 22ga. .032 |

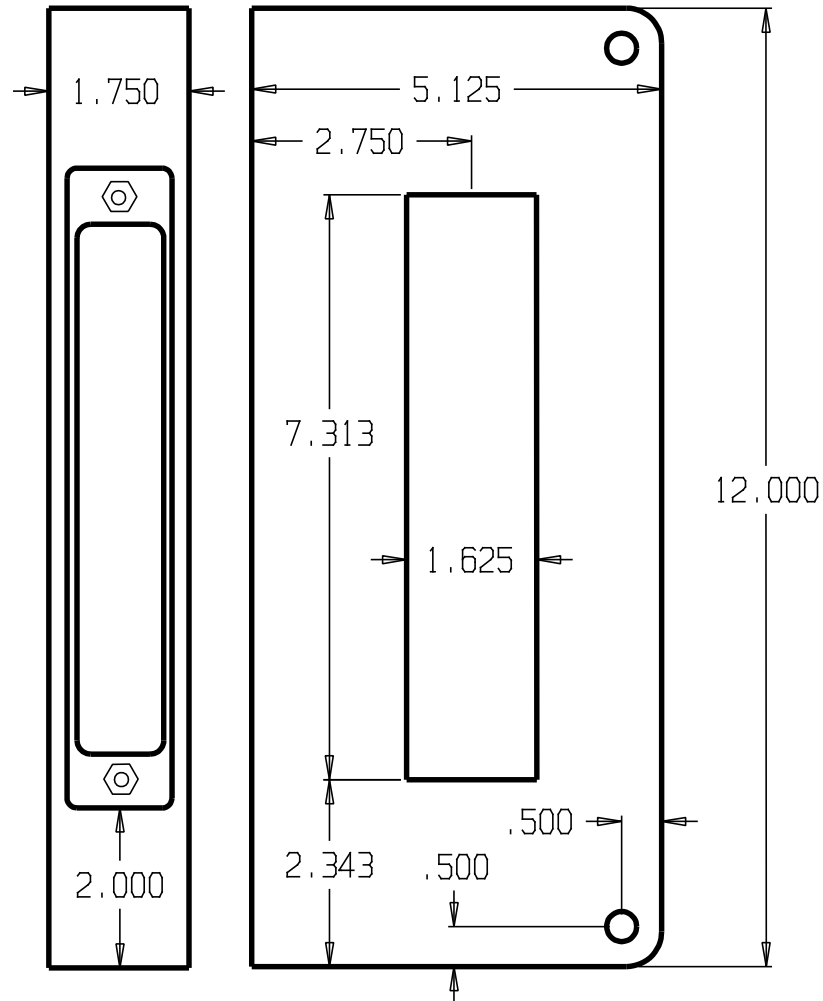

| | | | | | | | |
|------------------|--|-------|--------------|--------|-------|----------|-----|
| DON-JO MFG. INC. | | | | SIZE | DATE: | PART NO. | REV |
| DESIGNER | | A | 4/28/04 | 514-CW | | | |
| APPROVED | | SCALE | RELEASE DATE | WEIGHT | SHEET | | |

| REVISIONS | | | |
|-----------|-----|-----------------|------------|
| ZONE | REV | FINISHES: | GAUGE: |
| | | PB, BZ, 10B & S | 22ga. .032 |

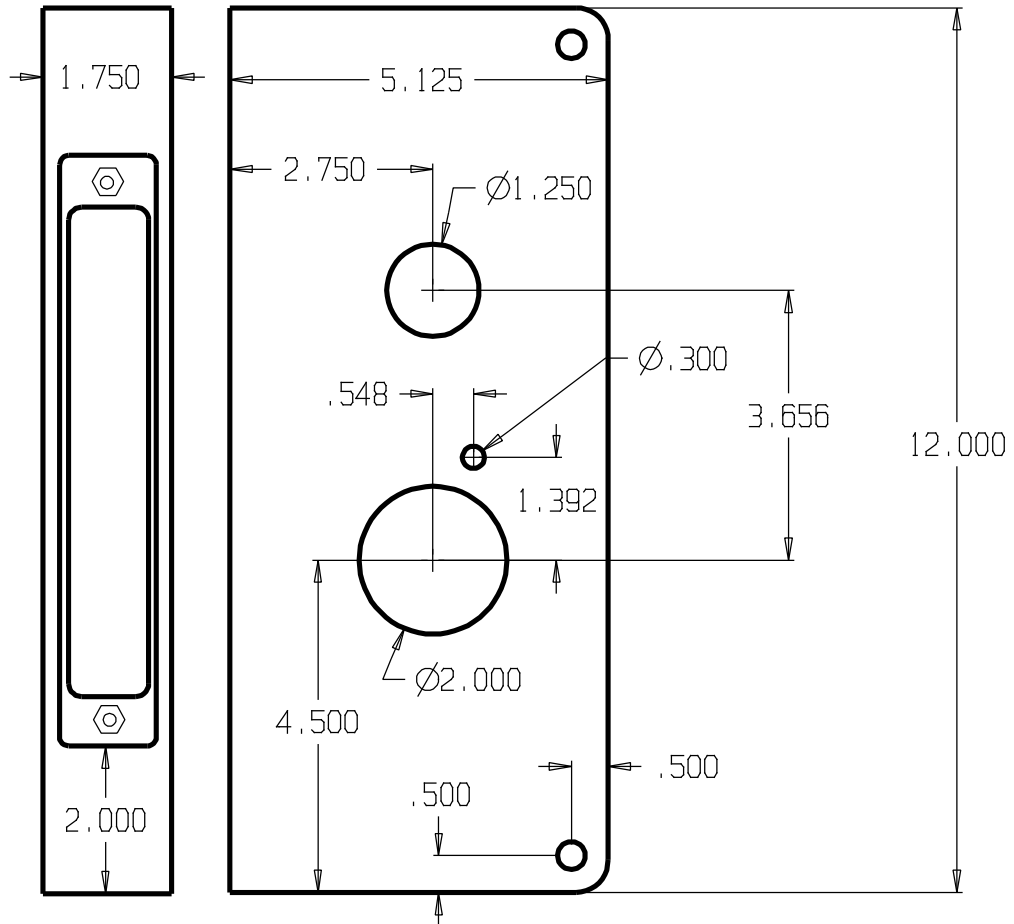

DON-JO MFG. INC.

| | | | | | |
|----------|--------------|--------|---------|----------|-----|
| DESIGNER | SCALE | SIZE | DATE: | PART NO. | REV |
| | | A | 2/16/04 | 518-CW | |
| APPROVED | RELEASE DATE | WEIGHT | SHEET | | |

| REVISIONS | | |
|-----------|-----|----------------|
| ZONE | REV | FINISHES: |
| | | PB, AB, BZ & S |
| | | Gauge: |
| | | 22ga. .032 |

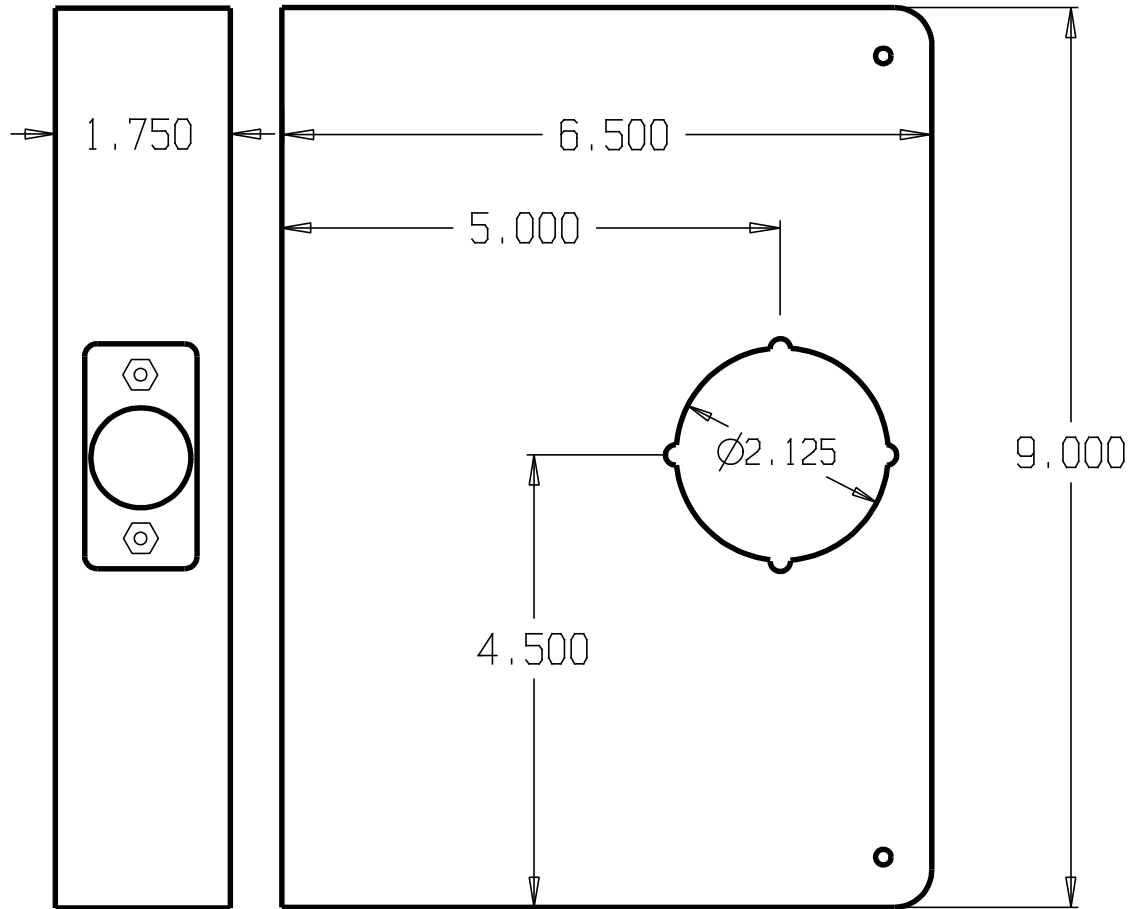

DON-JO MFG. INC.

| | | | | |
|----------|-------|--------------|----------|-------|
| DESIGNER | SIZE | DATE: | PART NO. | REV |
| | A | 4/28/04 | 55-CW | |
| APPROVED | SCALE | RELEASE DATE | WEIGHT | SHEET |
| | | | | |

| REVISIONS | | | |
|-----------|-----|----------------|------------|
| ZONE | REV | FINISHES: | GUAGE: |
| | | PB, AB, BZ & S | 22ga. .032 |

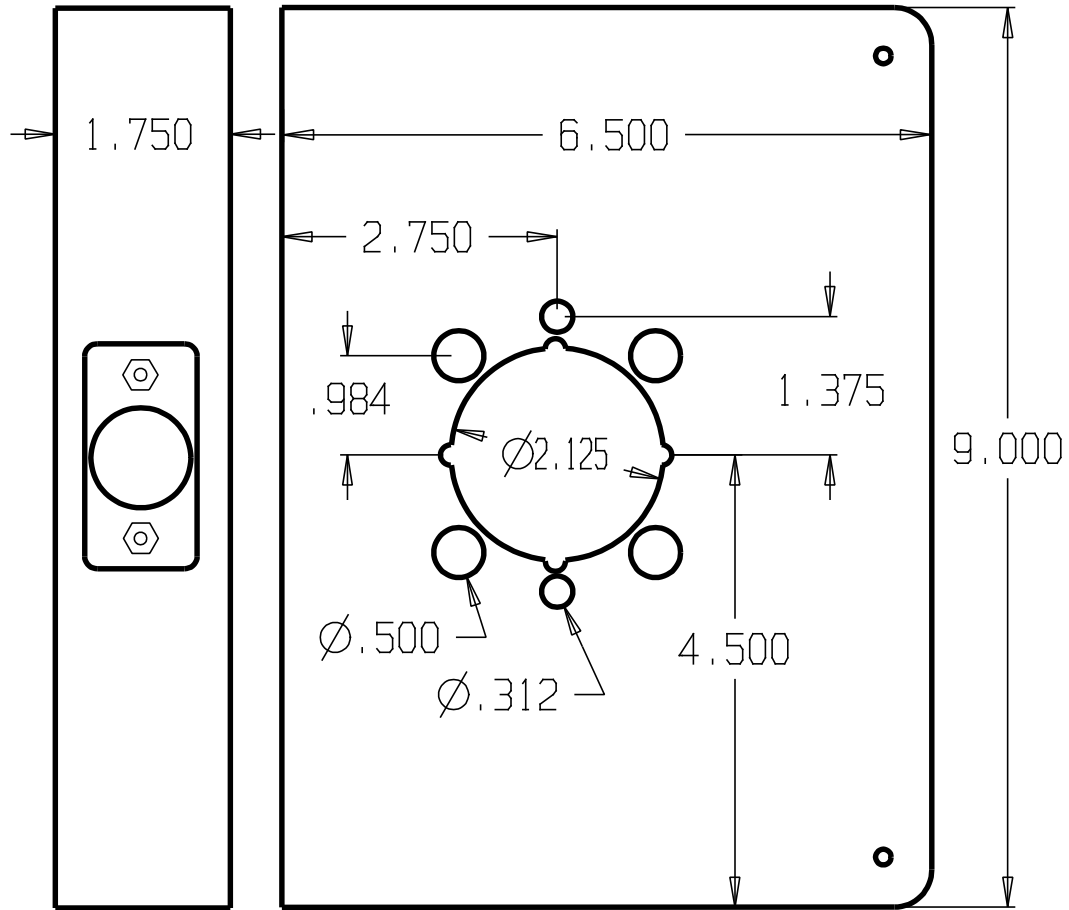

DON-JO MFG. INC.

| | | | | |
|----------|-------|--------------|----------|-------|
| DESIGNER | SIZE | DATE: | PART NO. | REV |
| | A | 4/28/04 | 55A-2-CW | |
| APPROVED | SCALE | RELEASE DATE | WEIGHT | SHEET |
| | | | | |

| REVISIONS | | |
|-----------|-----|--------------------|
| ZONE | REV | FINISHES: |
| | | PB, AB, BZ & S |
| | | GALUGE: 22ga. .032 |

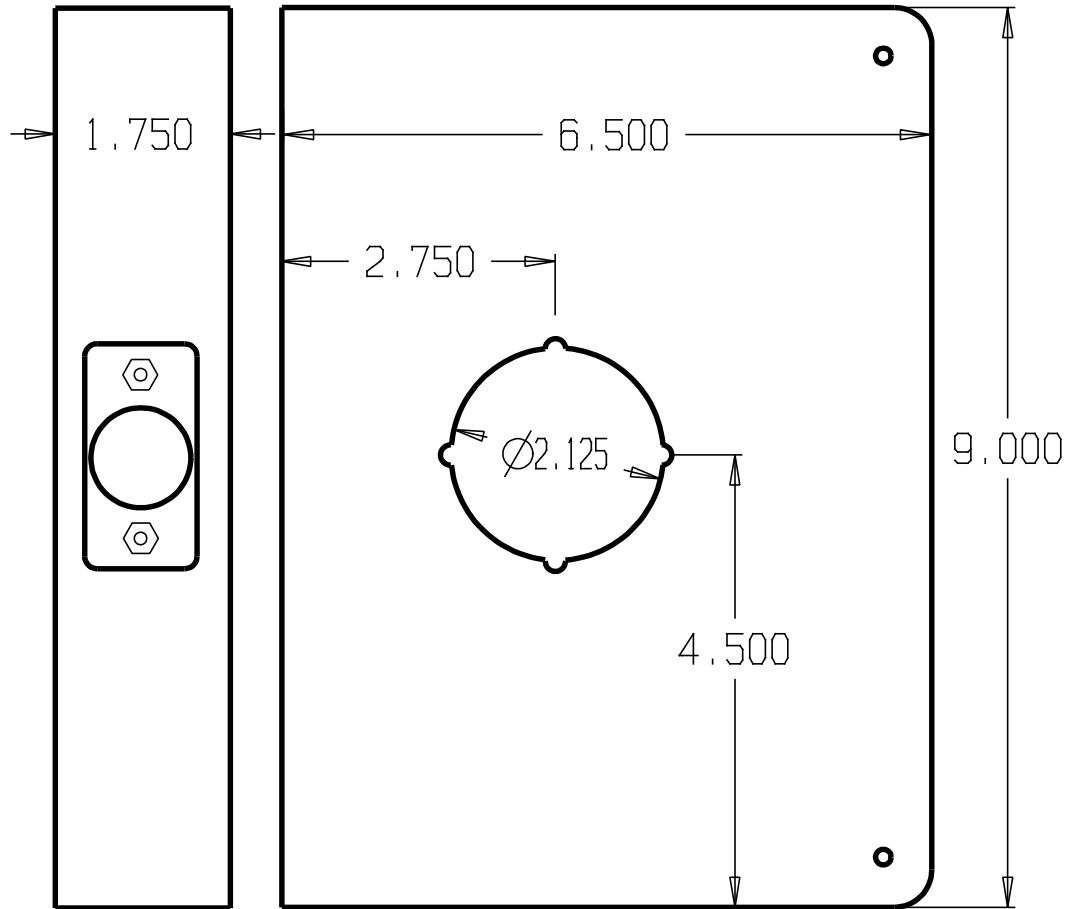

DON-JO MFG. INC.

| | | | | |
|----------|---------|---------------|-----------------|-------|
| DESIGNER | SIZE: A | DATE: 4/28/04 | PART NO. 55A-CW | REV |
| APPROVED | SCALE | RELEASE DATE | WEIGHT | SHEET |

| REVISIONS | | | |
|-----------|-----|----------------|------------|
| ZONE | REV | FINISHES: | GUAGE: |
| | | PB, AB, BZ & S | 22ga. .032 |

1.750

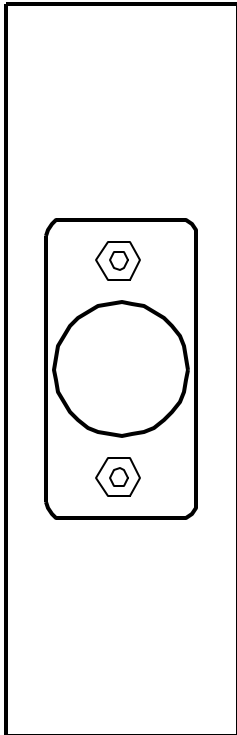

4.750

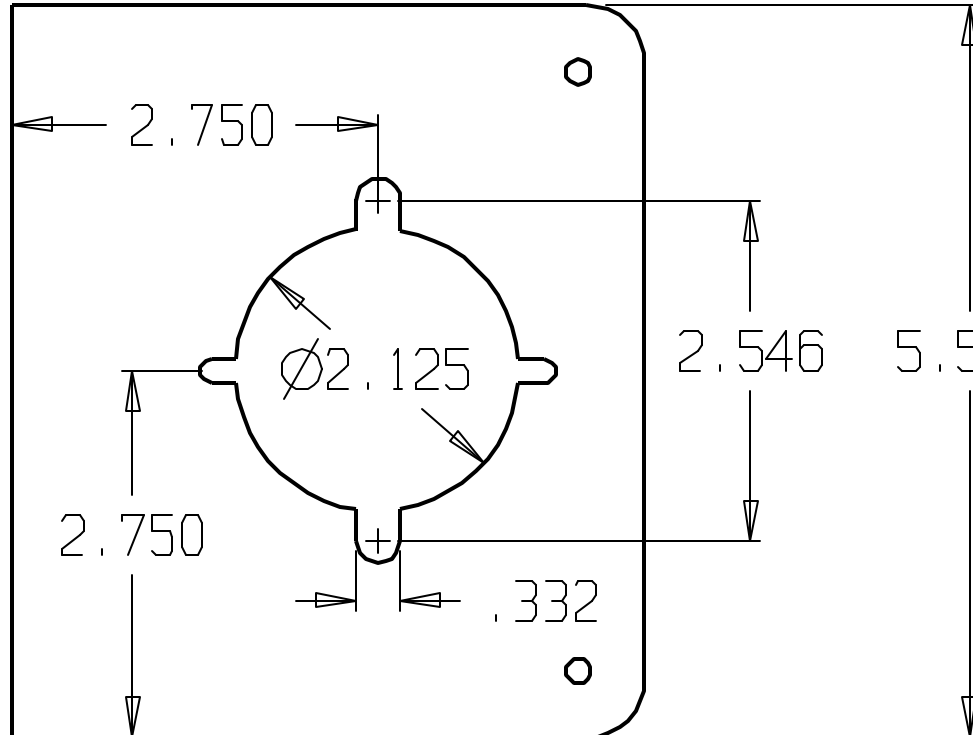

2.750

2.750

2.546

5.500

.332

DON-JO MFG. INC.

| | | | | |
|----------|-----------|------------------|-------------------|-------|
| DESIGNER | SIZE A | DATE: 4/28/04 | PART NO. 5K-CW | REV |
| APPROVED | SCALE | RELEASE DATE | WEIGHT | SHEET |

| REVISIONS | | | | |
|-----------|-----|---------------------|------|----------|
| ZONE | REV | FINISHES: | DATE | APPROVED |
| | | PB, AB, BZ, 10B & S | | |

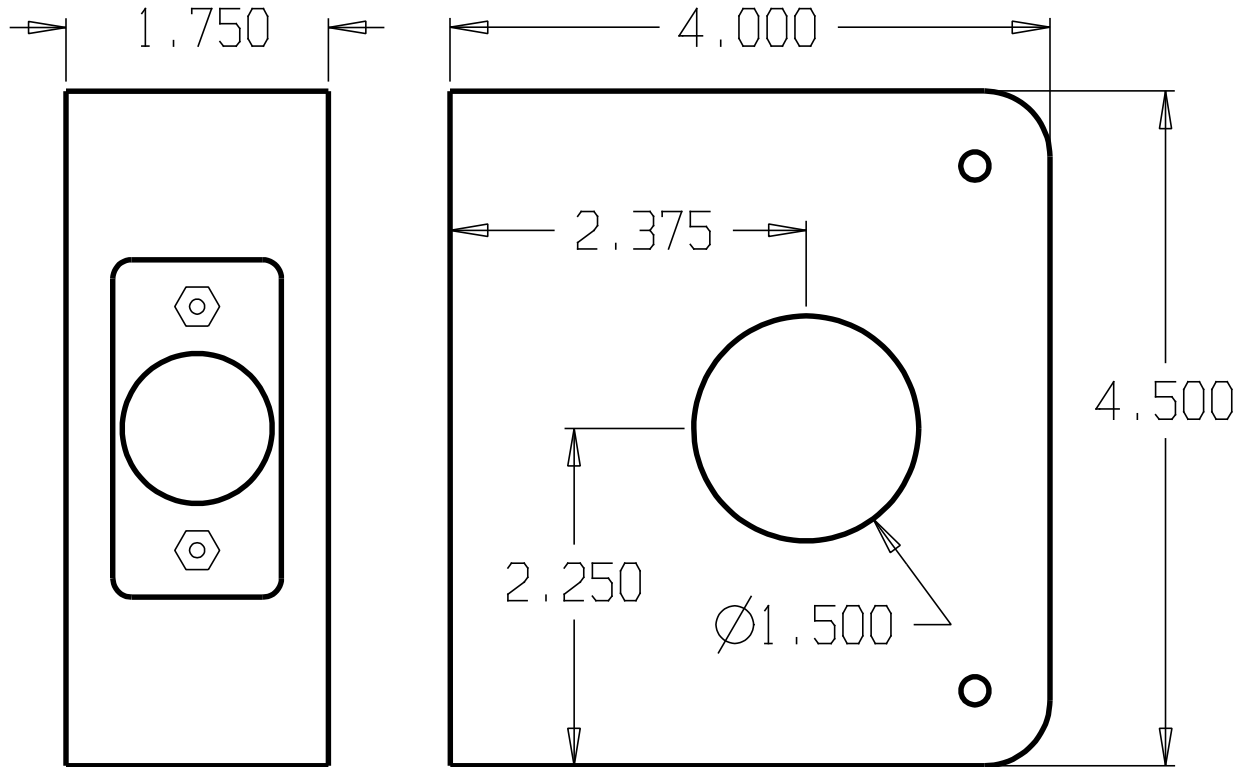

| | | | | |
|------------------|-------|--------------|----------|-------|
| DON-JO MFG. INC. | | | | |
| DESIGNER | SIZE | DATE: | PART NO. | REV |
| | A | 4/28/04 | 6-CW | |
| APPROVED | SCALE | RELEASE DATE | WEIGHT | SHEET |

| REVISIONS | | | | |
|-----------|-----|---------------------|------|----------|
| ZONE | REV | FINISHES: | DATE | APPROVED |
| | | PB, AB, BZ, 10B & S | | |

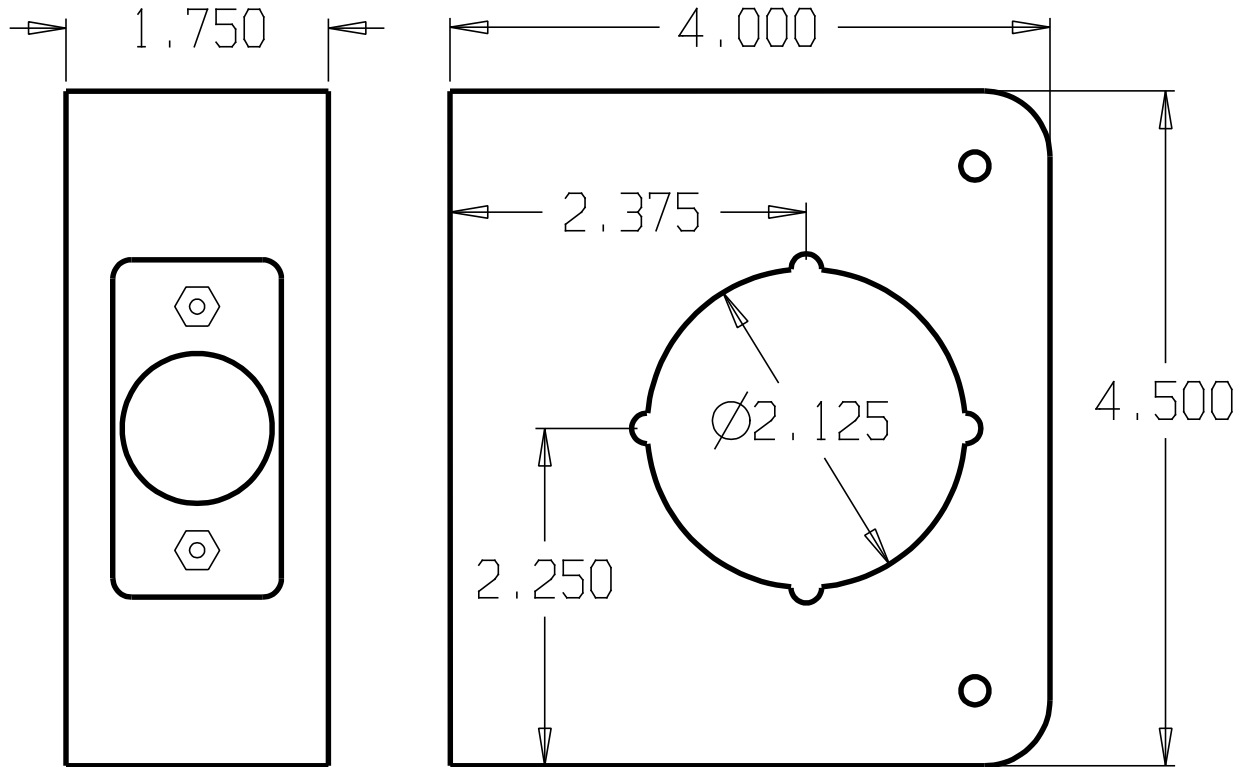

| | | | | | |
|------------------|--|-------|--------------|----------|-------|
| DON-JO MFG. INC. | | SIZE | DATE: | PART NO. | REV |
| DESIGNER | | A | 4/28/04 | 61-CW | |
| APPROVED | | SCALE | RELEASE DATE | WEIGHT | SHEET |

| REVISIONS | | | | |
|-----------|-----|---------------------|------|----------|
| ZONE | REV | FINISHES: | DATE | APPROVED |
| | | PB, AB, BZ, 10B & S | | |

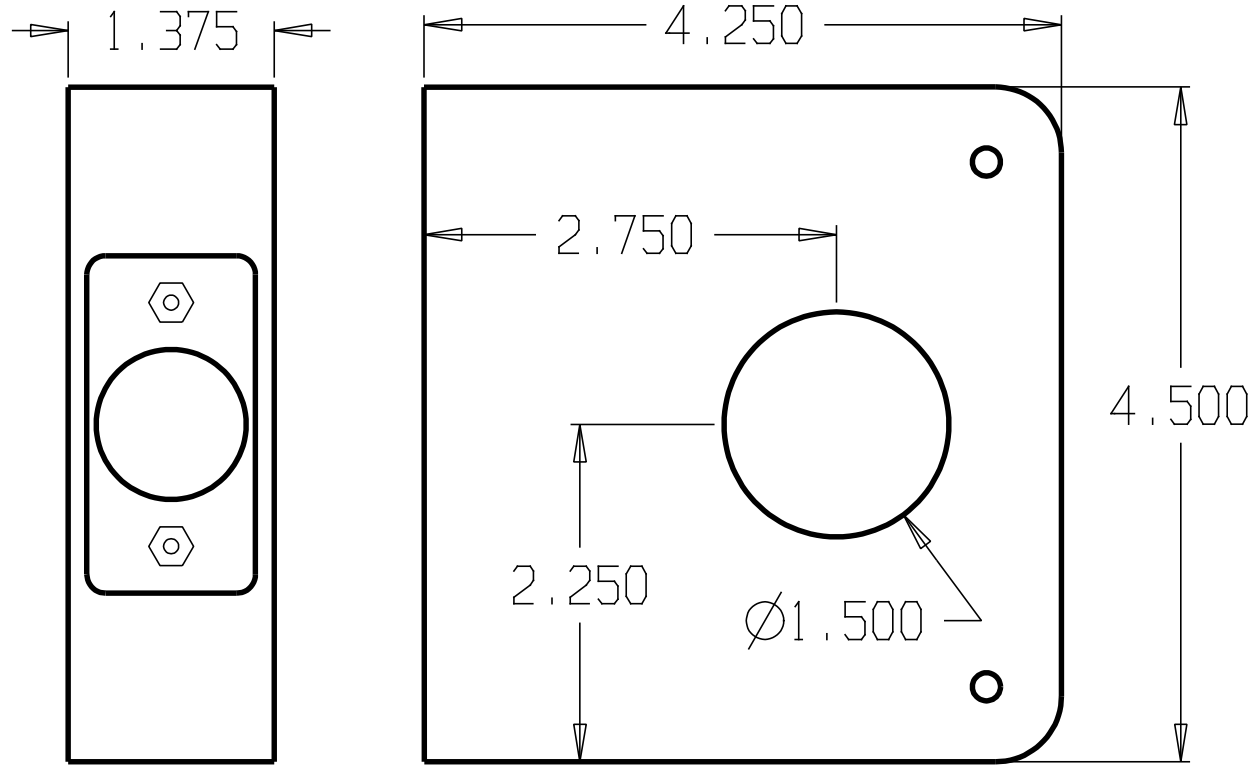

| | | | | | |
|------------------|--|-------|--------------|----------|-------|
| DON-JO MFG. INC. | | SIZE | DATE: | PART NO. | REV |
| DESIGNER | | A | 4/28/04 | 7-CW | |
| APPROVED | | SCALE | RELEASE DATE | WEIGHT | SHEET |

| REVISIONS | | | | |
|-----------|-----|---------------------|------|----------|
| ZONE | REV | FINISHES: | DATE | APPROVED |
| | | PB, AB, BZ, 10B & S | | |

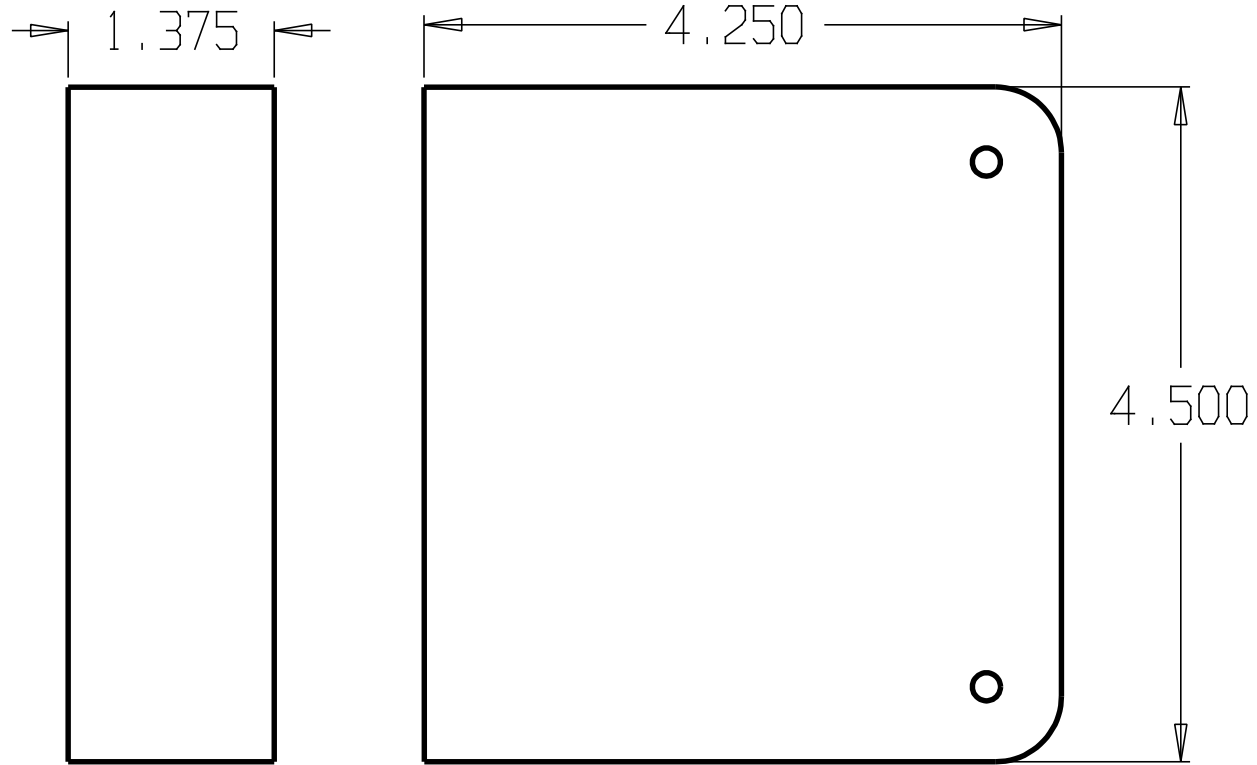

DON-JO MFG. INC.

| | |
|----------|--|
| DESIGNER | |
| APPROVED | |

| | | | |
|-------|--------------|----------|-------|
| SIZE | DATE: | PART NO. | REV |
| A | 4/28/04 | 70-CW | |
| SCALE | RELEASE DATE | WEIGHT | SHEET |

| REVISIONS | | | | |
|-----------|-----|---------------------|------|----------|
| ZONE | REV | FINISHES: | DATE | APPROVED |
| | | PB, AB, BZ, 10B & S | | |

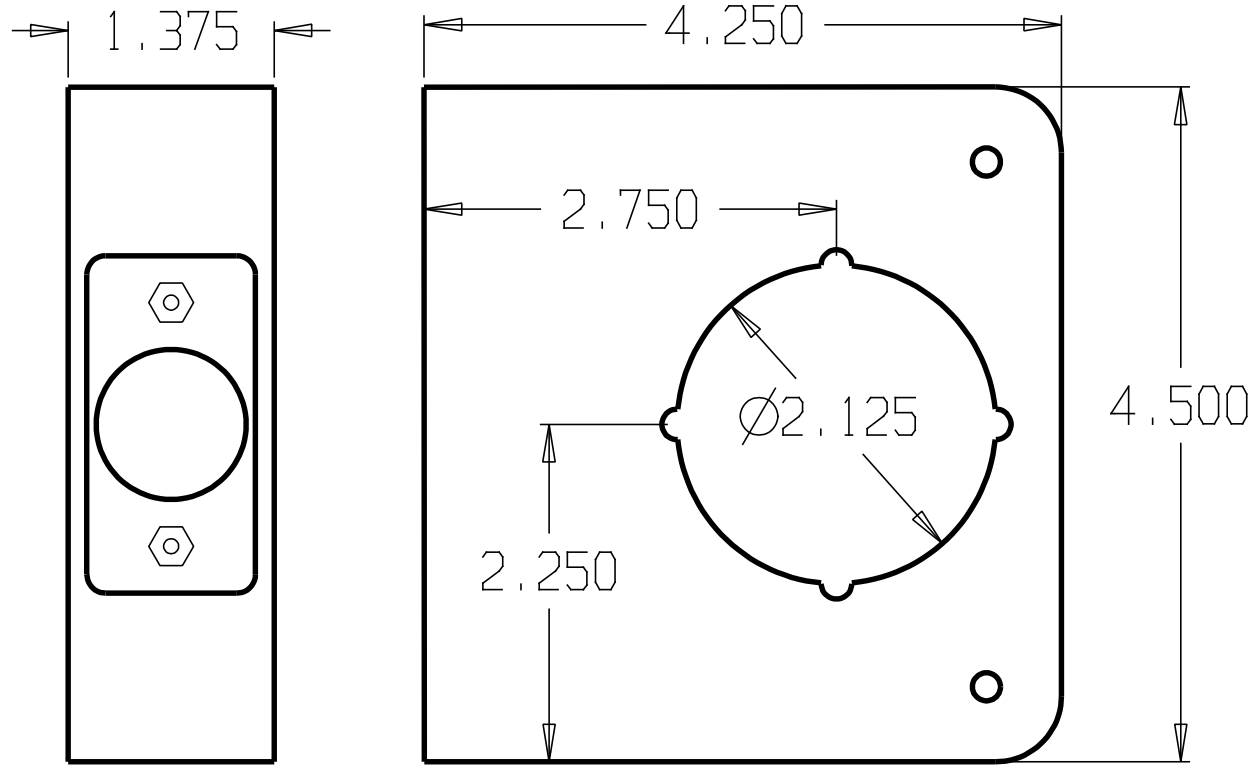

DON-JO MFG. INC.

| | |
|----------|--|
| DESIGNER | |
| APPROVED | |

| | | | |
|-------|--------------|----------|-------|
| SIZE | DATE: | PART NO. | REV |
| A | 4/28/04 | 71-CW | |
| SCALE | RELEASE DATE | WEIGHT | SHEET |

| REVISIONS | | | | |
|-----------|-----|----------------|------|----------|
| ZONE | REV | FINISHES: | DATE | APPROVED |
| | | PB, AB, BZ & S | | |

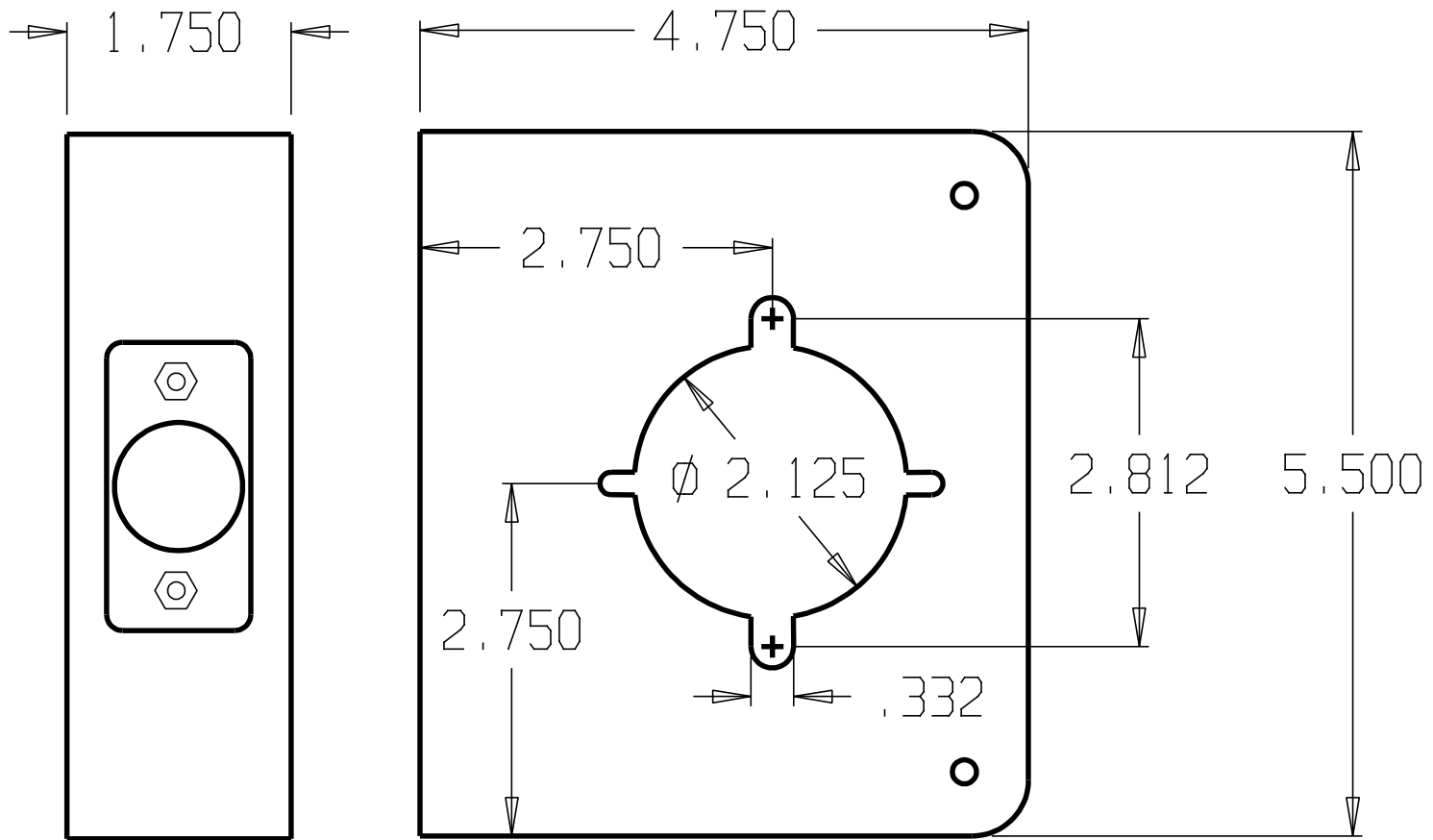

DON-JO MFG. INC.

| | | | | |
|----------|-------|--------------|----------|-------|
| DESIGNER | SIZE | DATE: | PART NO. | REV |
| | A | 4/28/04 | 75-CW | |
| APPROVED | SCALE | RELEASE DATE | WEIGHT | SHEET |
| | | | | |

| REVISIONS | | | |
|-----------|-----|---------------------|----------|
| ZONE | REV | FINISHES: | DATE |
| | | PB, AB, BZ, 10B & S | |
| | | DATE | APPROVED |
| | | | |

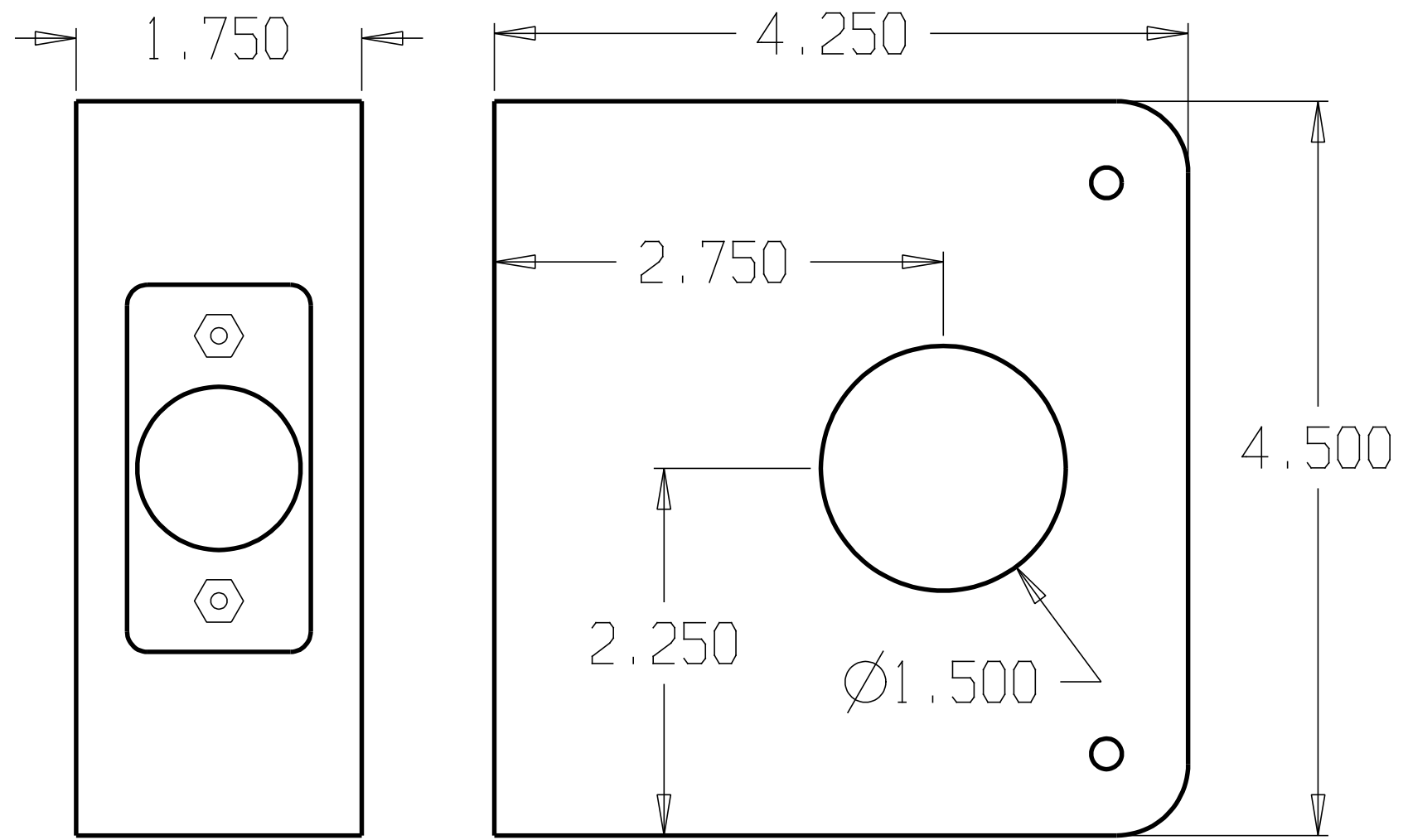

DON-JO MFG. INC.

| | | | | |
|----------|-----------|------------------|------------------|-------|
| DESIGNER | SIZE A | DATE: 4/28/04 | PART NO. 8-CW | REV |
| APPROVED | SCALE | RELEASE DATE | WEIGHT | SHEET |

| REVISIONS | | |
|-----------|-----|---------------------|
| ZONE | REV | FINISHES: |
| | | PB, AB, BZ, 10B & S |
| | | GUAGE: |
| | | 22ga. .032 |

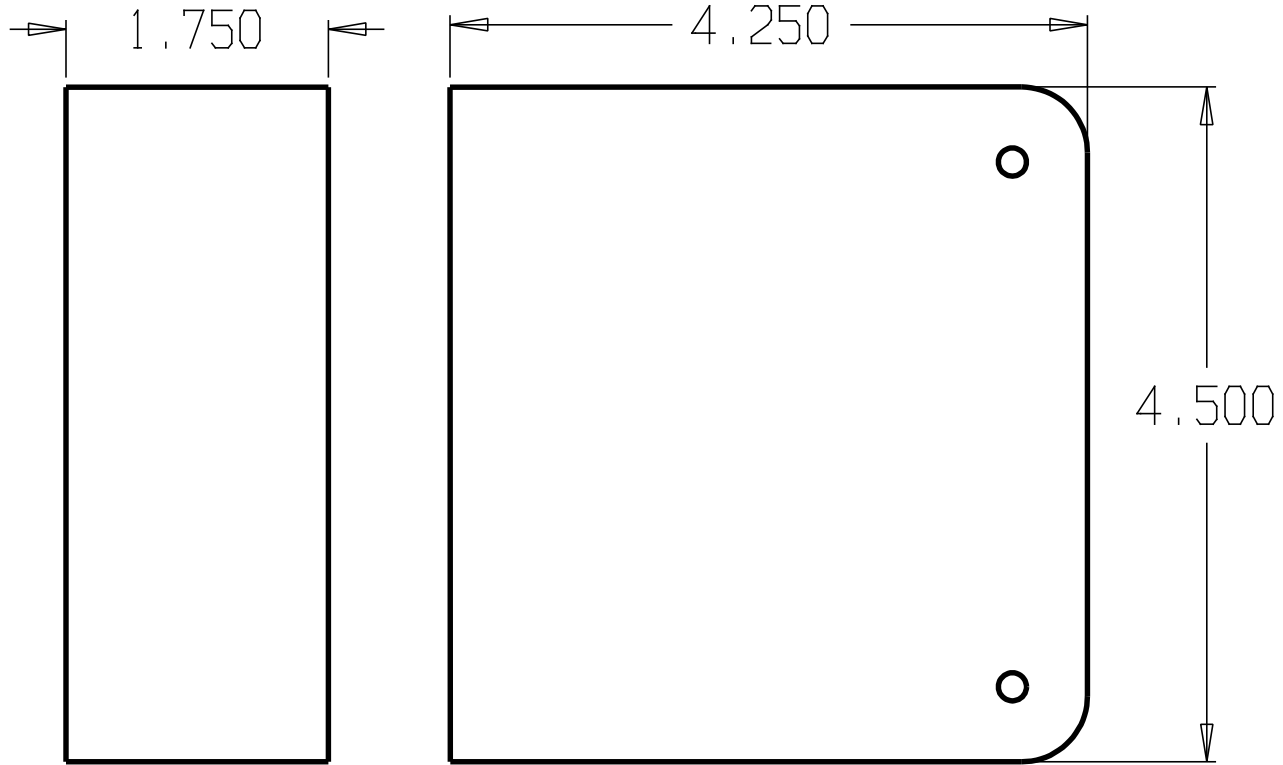

DON-JO MFG. INC.

| | |
|----------|--|
| DESIGNER | |
| APPROVED | |

| | | | |
|-------|--------------|----------|-------|
| SIZE | DATE: | PART NO. | REV |
| A | 4/28/04 | 80-CW | |
| SCALE | RELEASE DATE | WEIGHT | SHEET |

| REVISIONS | | |
|-----------|-----|---------------------|
| ZONE | REV | FINISHES: |
| | | PB, AB, BZ, 10B & S |
| | | GALUGE: |
| | | 22ga. .032 |

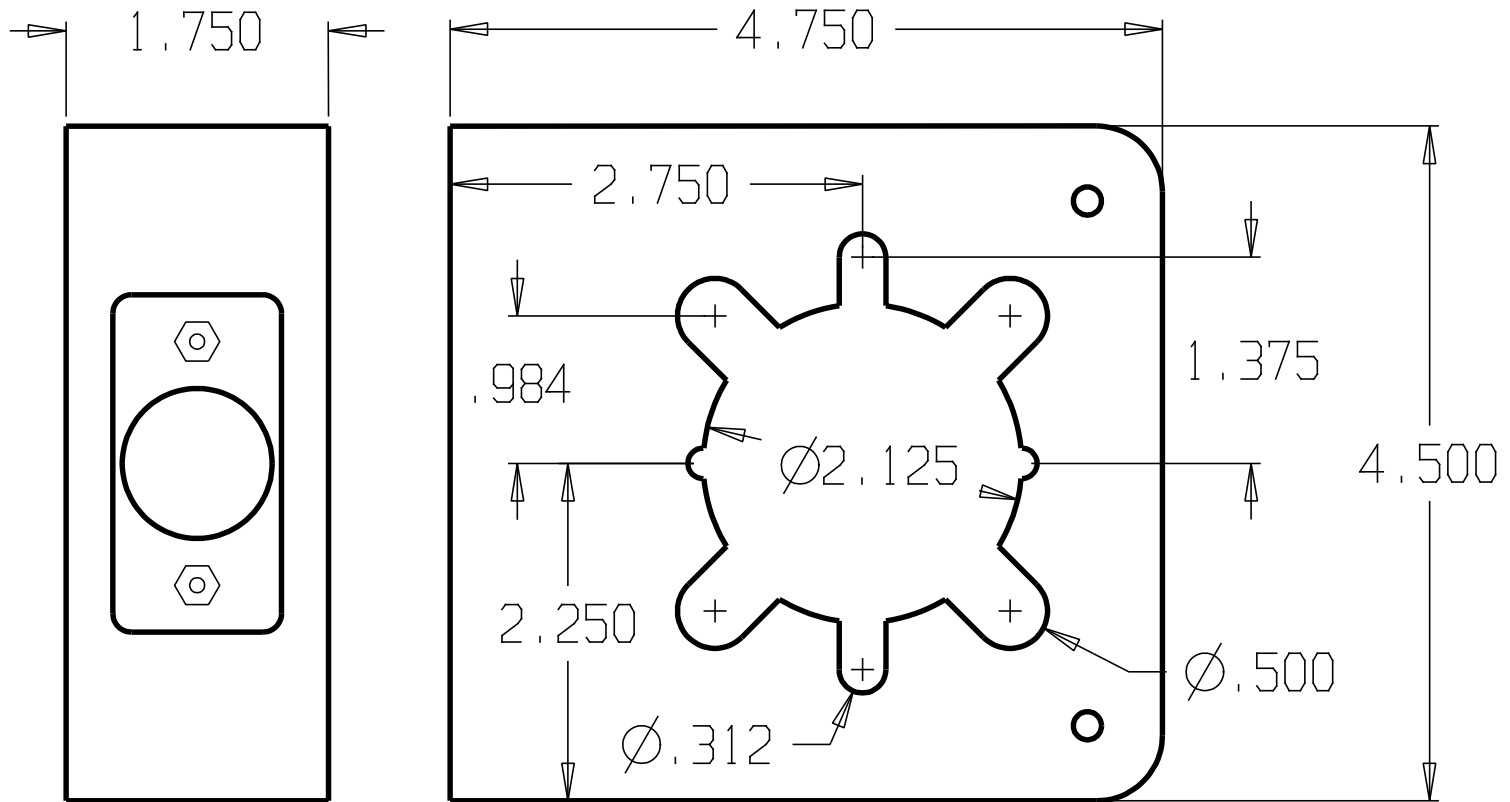

DON-JO MFG. INC.

| | | | | |
|----------|-------|--------------|----------|-------|
| DESIGNER | SIZE | DATE: | PART NO. | REV |
| | A | 5/21/12 | 81-2-CW | |
| APPROVED | SCALE | RELEASE DATE | WEIGHT | SHEET |
| | | | | |

| REVISIONS | | | | |
|-----------|-----|---------------------|------|----------|
| ZONE | REV | FINISHES: | DATE | APPROVED |
| | | PB, AB, BZ, 10B & S | | |

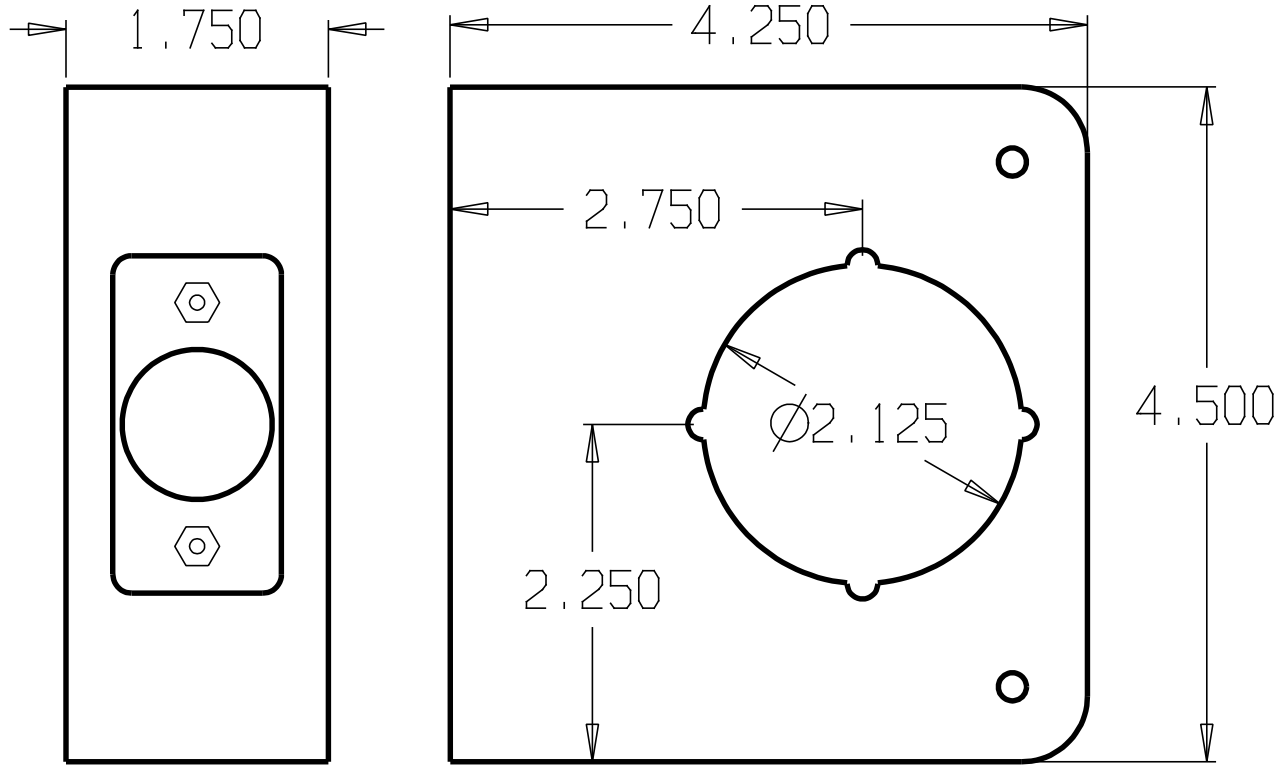

DON-JO MFG. INC.

| | | | | |
|----------|-------|--------------|----------|-------|
| DESIGNER | SIZE | DATE: | PART NO. | REV |
| | A | 4/28/04 | 81-CW | |
| APPROVED | SCALE | RELEASE DATE | WEIGHT | SHEET |
| | | | | |

| REVISIONS | | | |
|-----------|-----|------------|----------|
| ZONE | REV | FINISHES: | DATE |
| | | PB, AB & S | |
| | | | APPROVED |

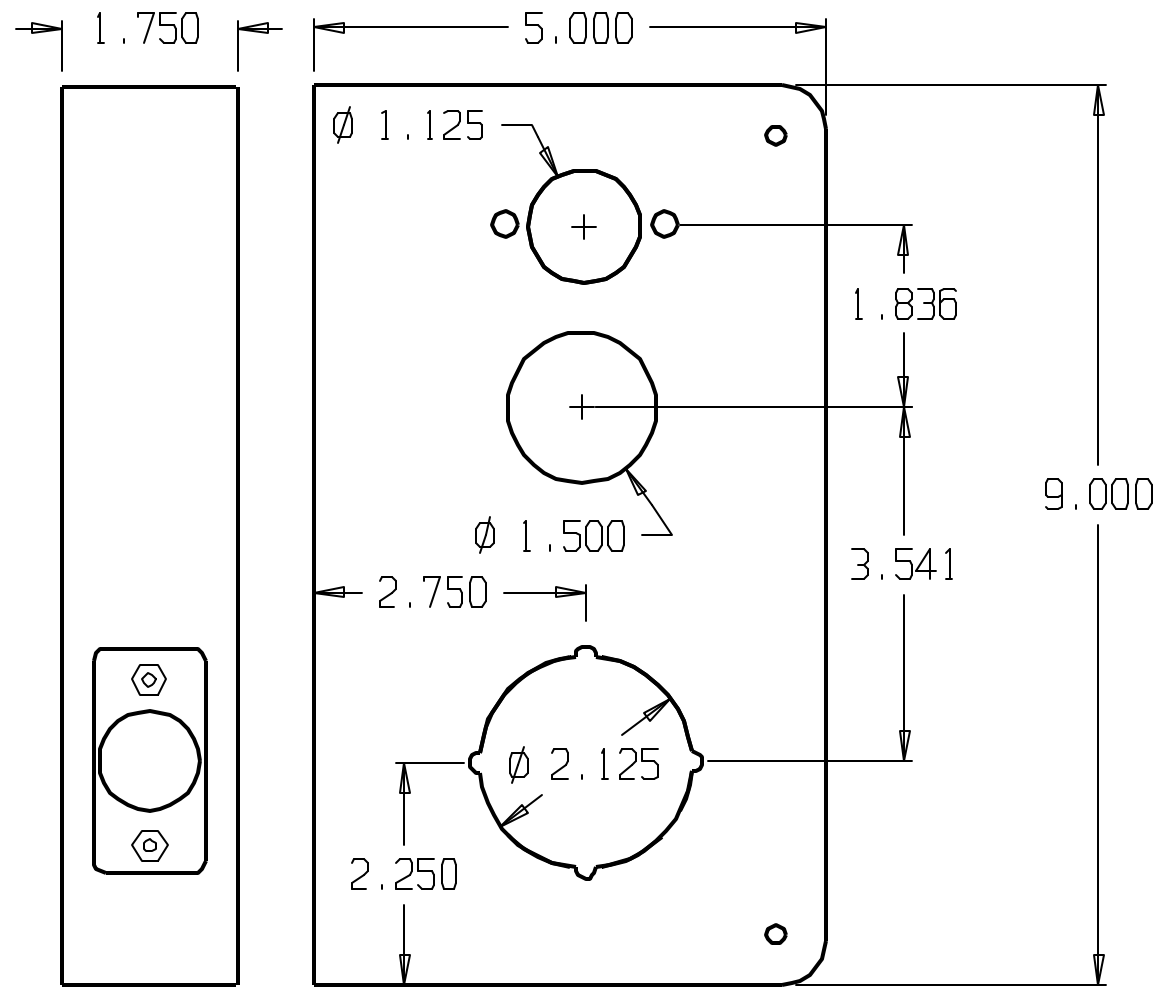

DON-JO MFG. INC.

| | | | | |
|----------|-------|--------------|----------|-------|
| DESIGNER | SIZE | DATE | PART NO. | REV |
| | A | 5/31/11 | 9-CW | |
| APPROVED | SCALE | RELEASE DATE | WEIGHT | SHEET |

DWG NO. SH REV

REVISIONS

| ZONE | REV | FINISHES: | DATE | APPROVED |
|------|-----|---------------------|------|----------|
| | | PB, AB, BZ, 10B & S | | |

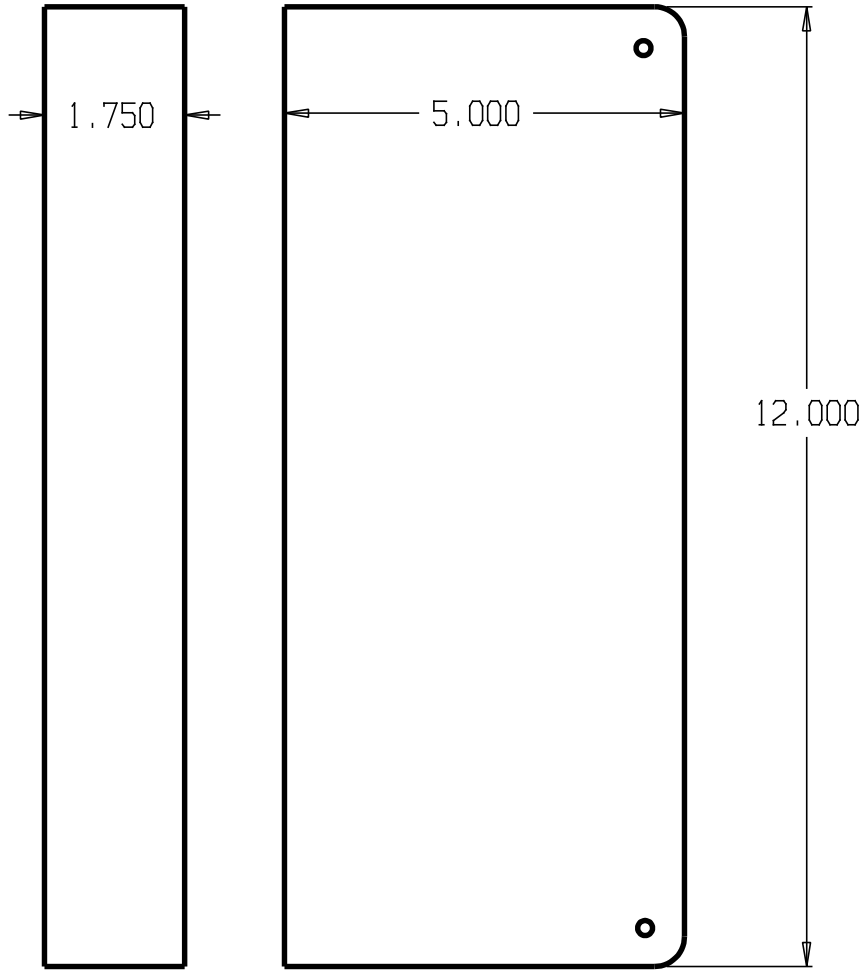

DON-JO MFG. INC.

| | | | | | |
|----------|--|-----------|------------------|-------------------|-------|
| DESIGNER | | SIZE A | DATE: 4/30/04 | PART NO. 90-CW | REV |
| APPROVED | | SCALE | RELEASE DATE | WEIGHT | SHEET |

| REVISIONS | | | |
|-----------|-----|------------|------------|
| ZONE | REV | FINISHES: | GUAGE: |
| | | PB, AB & S | 22ga. .032 |

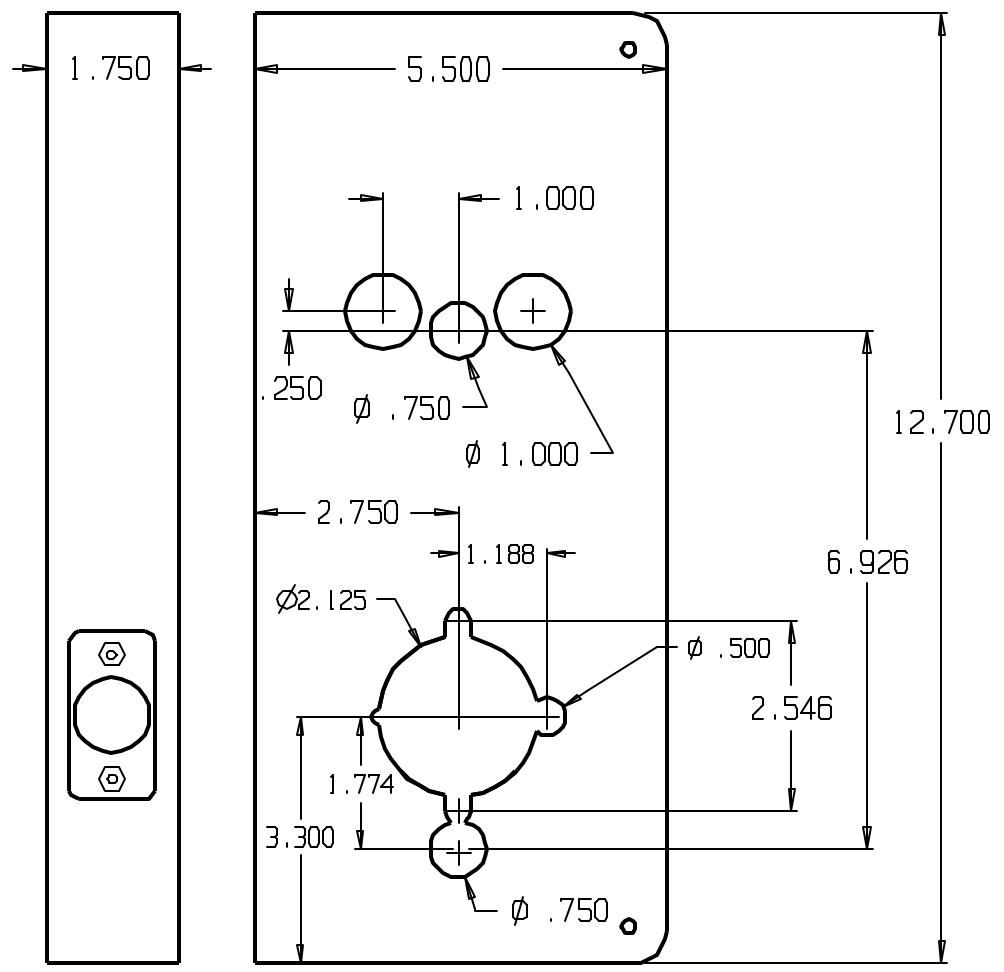

DON-JO MFG. INC.

| | | | | |
|----------|-------|--------------|----------|-------|
| DESIGNER | SIZE | DATE | PART NO. | REV |
| | A | 4/30/04 | 93KV-CW | |
| APPROVED | SCALE | RELEASE DATE | WEIGHT | SHEET |

| REVISIONS | | |
|-----------|-----|---------------------|
| ZONE | REV | FINISHES: |
| | | PB, AB, BZ, 10B & S |
| | | GALUGE: |
| | | 22ga. .032 |

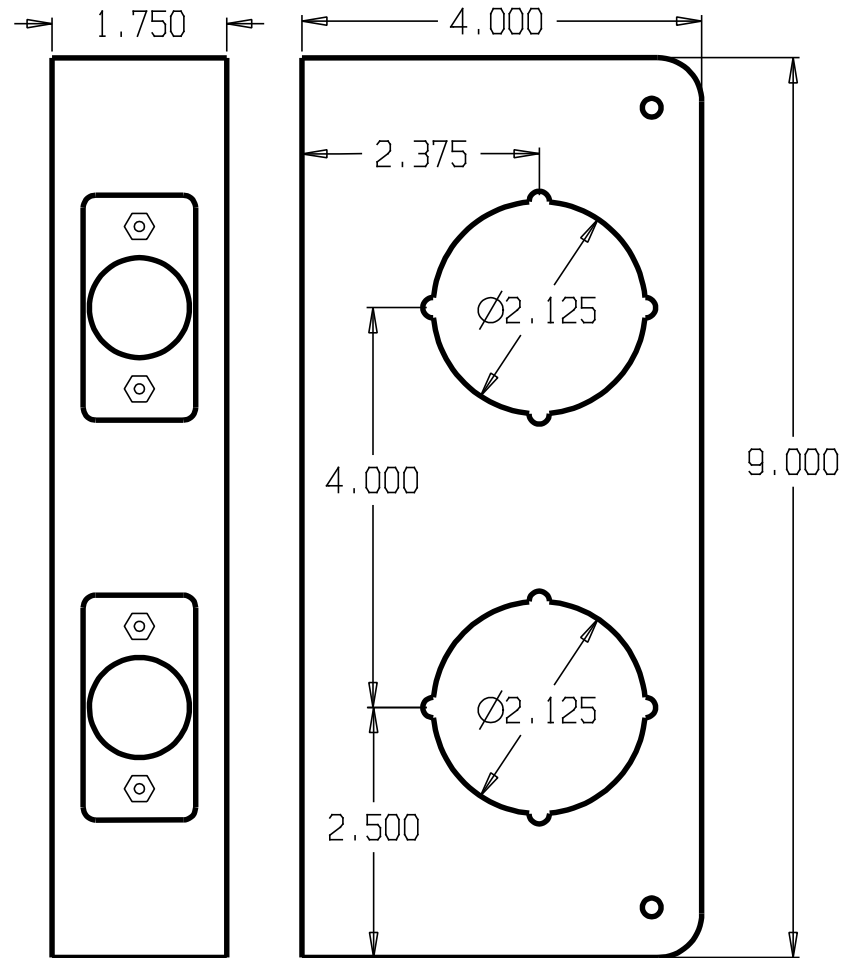

DON-JO MFG. INC.

| | | | | |
|----------|-------|--------------|----------|-------|
| DESIGNER | SIZE | DATE: | PART NO. | REV |
| | A | 4/5/04 | 942-CW | |
| APPROVED | SCALE | RELEASE DATE | WEIGHT | SHEET |
| | | | | |

| REVISIONS | | | | |
|-----------|-----|---------------------|------|----------|
| ZONE | REV | FINISHES: | DATE | APPROVED |
| | | PB, AB, BZ, 10B & S | | |

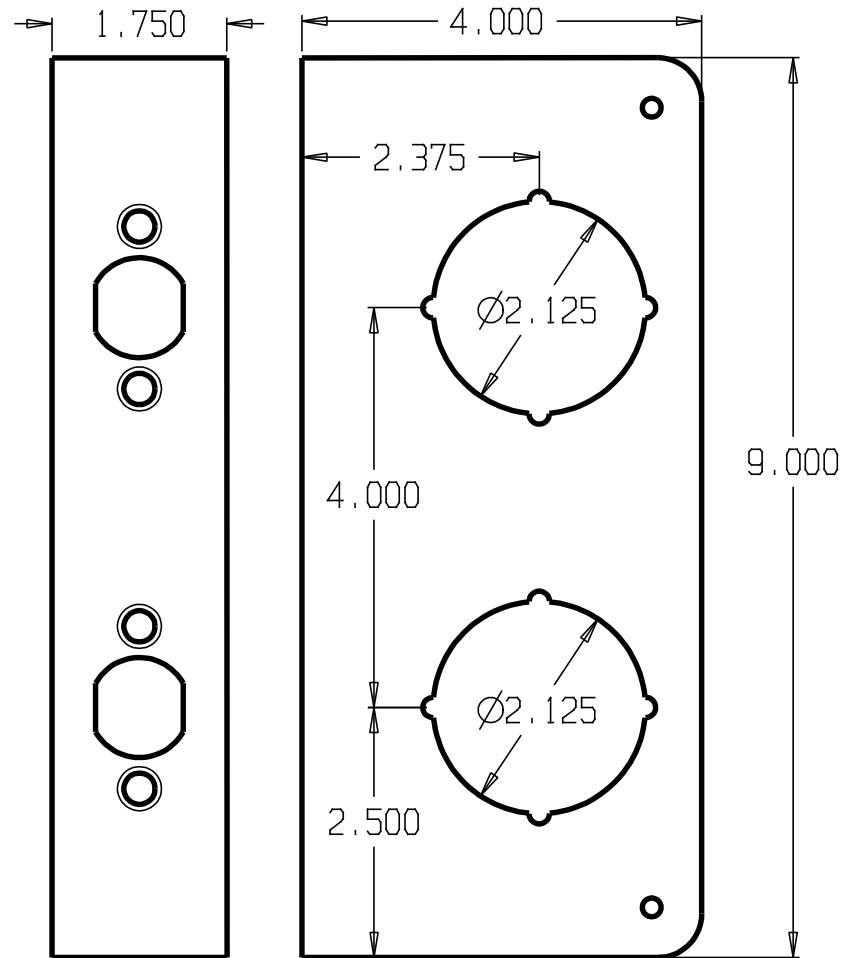

DON-JO MFG. INC.

| | | | | |
|----------|-----------|-----------------|--------------------|-------|
| DESIGNER | SIZE A | DATE: 4/5/04 | PART NO. 942-VF | REV |
| APPROVED | SCALE | RELEASE DATE | WEIGHT | SHEET |

| REVISIONS | | |
|-----------|-----|---------------------|
| ZONE | REV | FINISHES: |
| | | PB, AB, BZ, 10B & S |
| | | GAUGE: |
| | | 22ga. .032 |

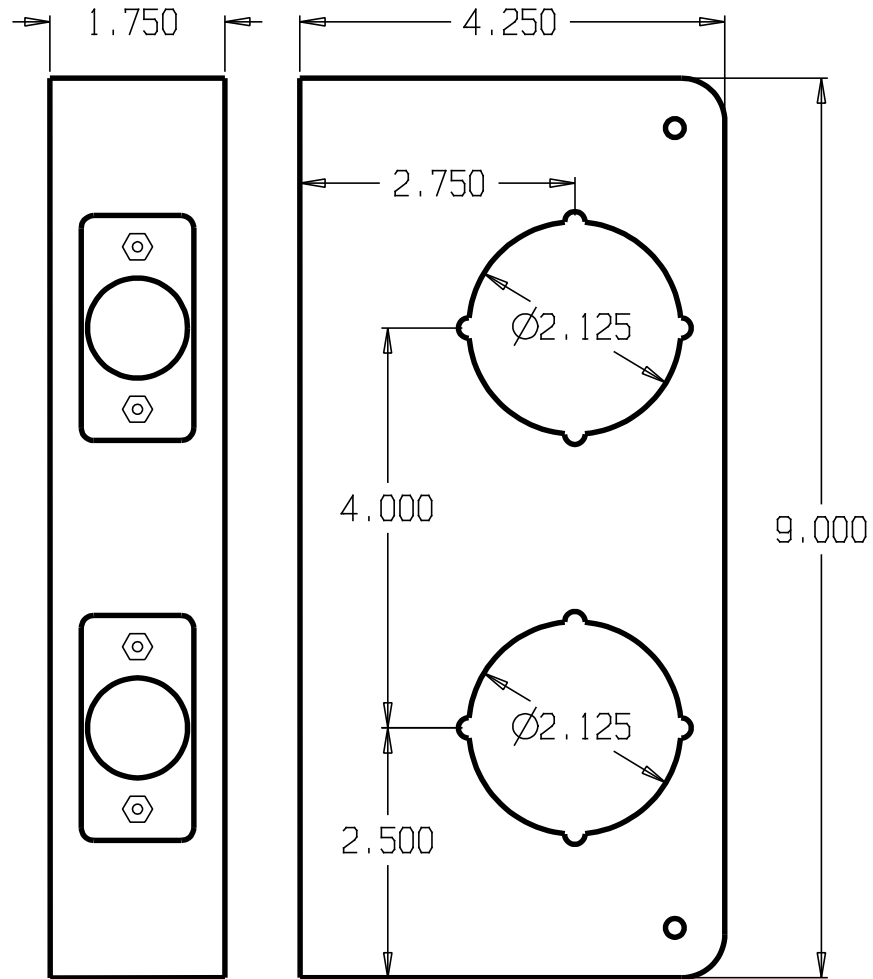

DON-JO MFG. INC.

| | | | | |
|----------|-------|--------------|----------|-------|
| DESIGNER | SIZE | DATE: | PART NO. | REV |
| | A | 4/28/04 | 943-CW | |
| APPROVED | SCALE | RELEASE DATE | WEIGHT | SHEET |
| | | | | |

| REVISIONS | | | |
|-----------|-----|---------------------|----------|
| ZONE | REV | FINISHES: | DATE |
| | | PB, AB, BZ, 10B & S | |
| | | | APPROVED |

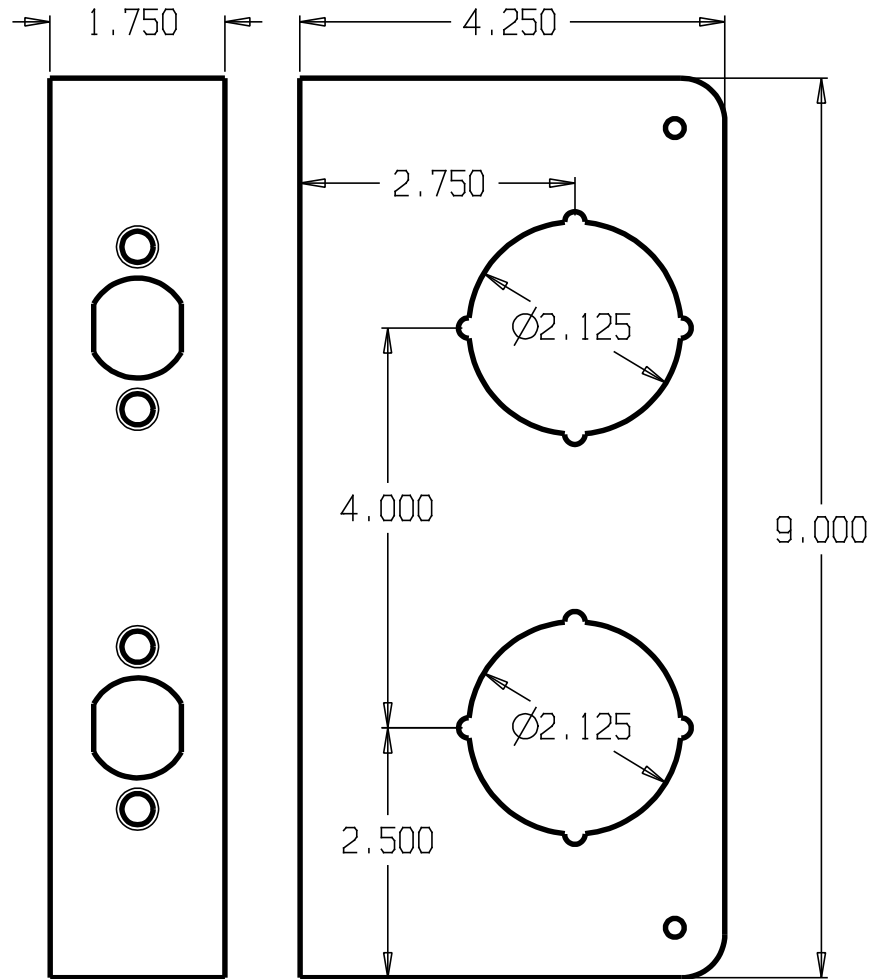

DON-JO MFG. INC.

| | | | | |
|----------|-------|--------------|----------|-------|
| DESIGNER | SIZE | DATE: | PART NO. | REV |
| | A | 4/28/04 | 943-VF | |
| APPROVED | SCALE | RELEASE DATE | WEIGHT | SHEET |
| | | | | |

| REVISIONS | | | |
|-----------|-----|-----------|------------|
| ZONE | REV | FINISHES: | GALUGE: |
| | | PB & S | 22ga. .032 |

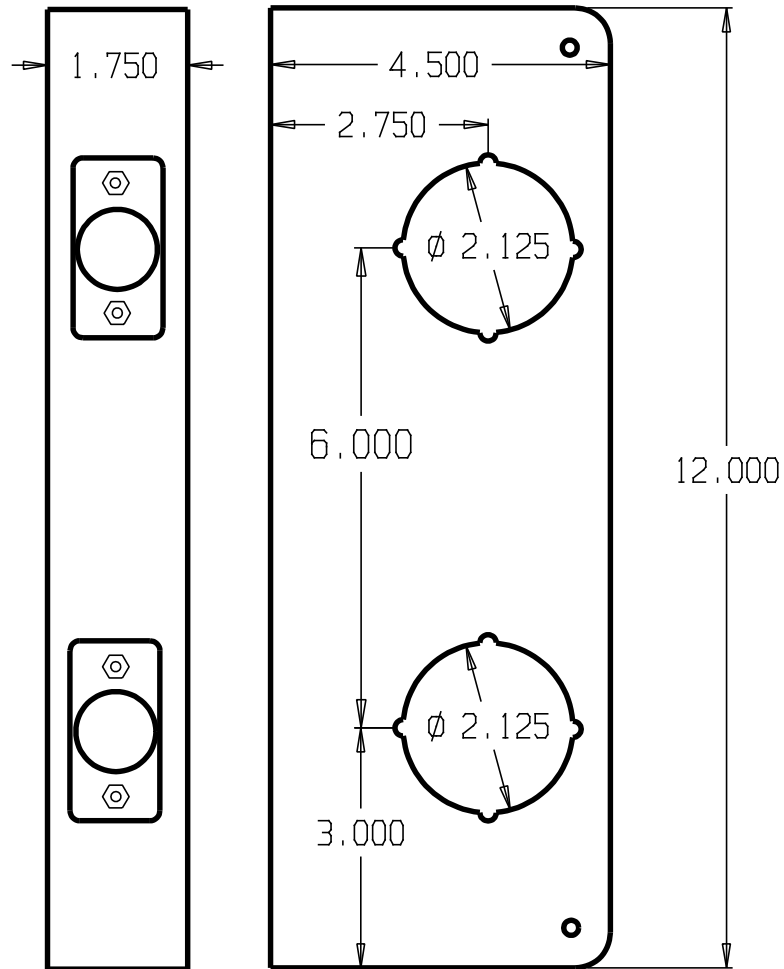

DON-JO MFG. INC.

| | | | | |
|----------|-------|--------------|----------|-------|
| DESIGNER | SIZE | DATE: | PART NO. | REV |
| | A | 4/28/04 | 946-CW | |
| APPROVED | SCALE | RELEASE DATE | WEIGHT | SHEET |
| | | | | |

| REVISIONS | | | | |
|-----------|-----|----------------|------|----------|
| ZONE | REV | FINISHES: | DATE | APPROVED |
| | | PB, AB, BZ & S | | |

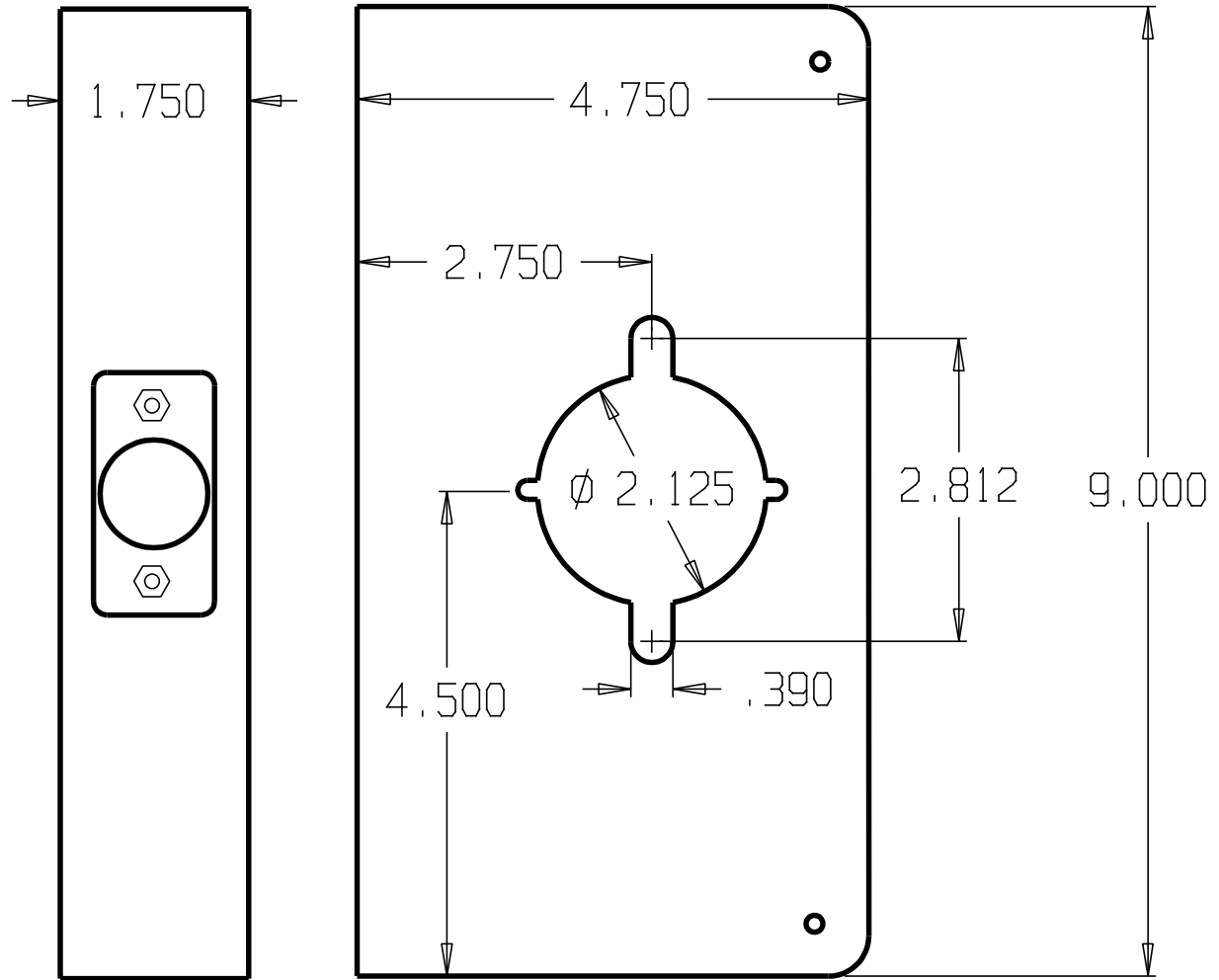

| | | | | |
|------------------|-------|--------------|----------|-------|
| DON-JO MFG. INC. | | | | |
| DESIGNER | SIZE | DATE: | PART NO. | REV |
| | A | 3/16/05 | 95-CW | |
| APPROVED | SCALE | RELEASE DATE | WEIGHT | SHEET |

| REVISIONS | | | | |
|-----------|-----|----------------|------|----------|
| ZONE | REV | FINISHES: | DATE | APPROVED |
| | | PB, AB, BZ & S | | |

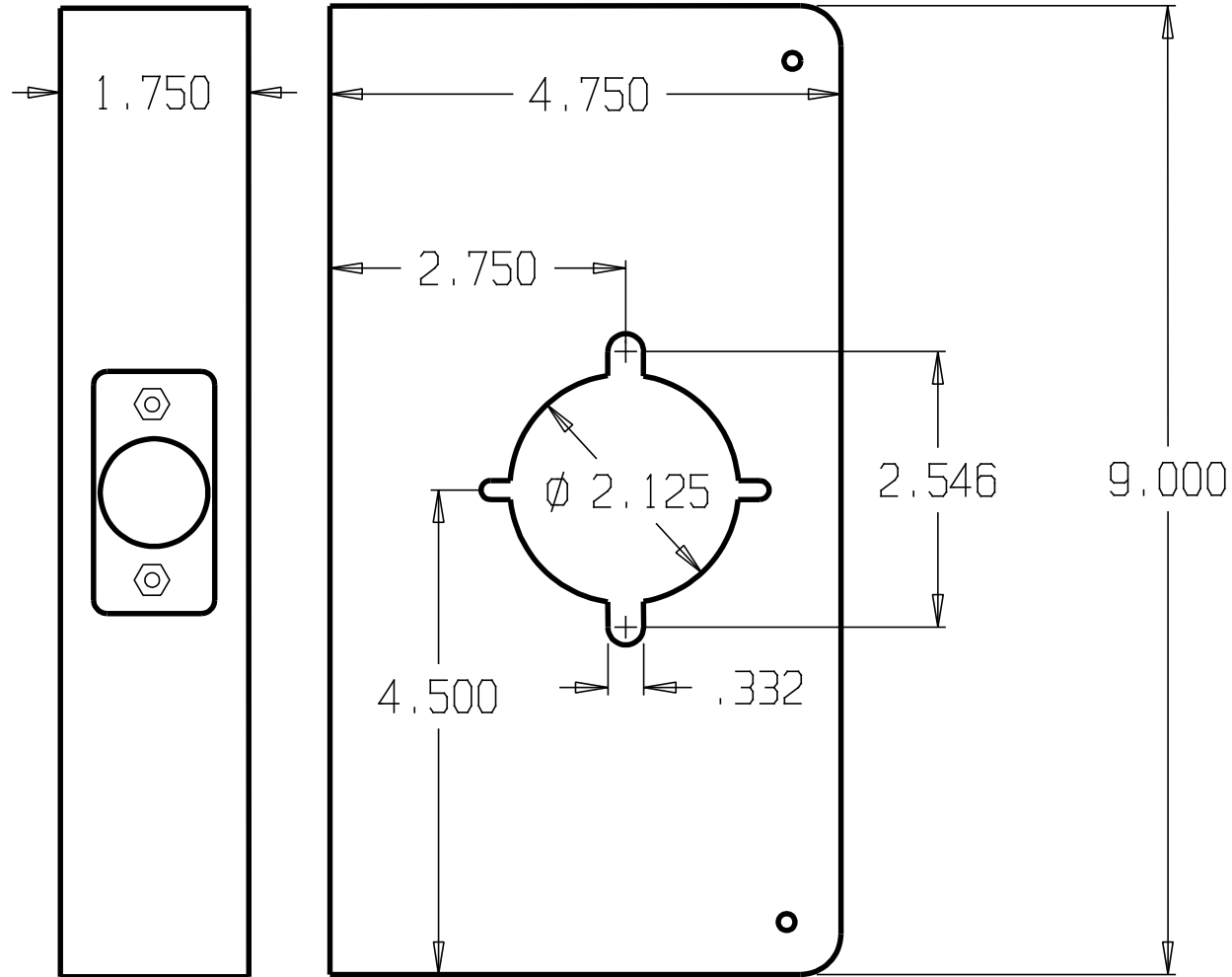

DON-JO MFG. INC.

| | |
|----------|--|
| DESIGNER | |
| APPROVED | |

| | | | |
|-----------|------------------|-------------------|-------|
| SIZE A | DATE: 4/30/04 | PART NO. 9K-CW | REV |
| SCALE | RELEASE DATE | WEIGHT | SHEET |

| REVISIONS | | | |
|-----------|-----|-----------|------------|
| ZONE | REV | FINISHES: | GALUGE: |
| | | 605, 630 | 22ga. .032 |

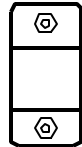
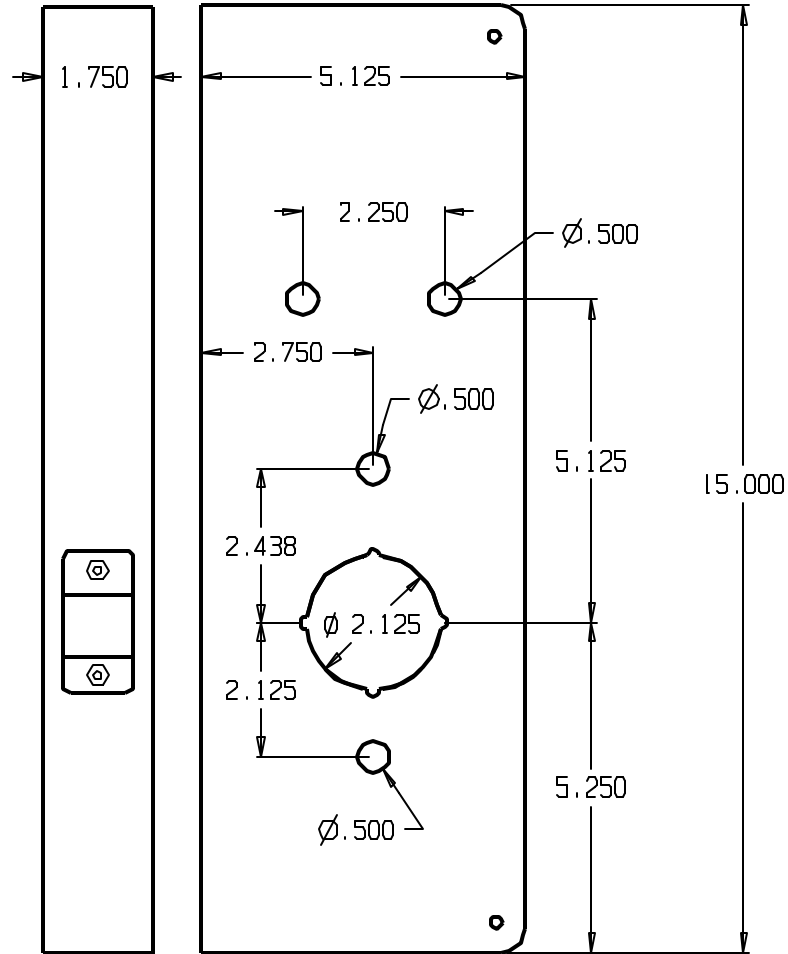

DON-JO MFG. INC.

| | | | | |
|----------|-------|--------------|----------|-------|
| DESIGNER | SIZE | DATE | PART NO. | REV |
| | A | 7/12/07 | E2000-CW | |
| APPROVED | SCALE | RELEASE DATE | WEIGHT | SHEET |