

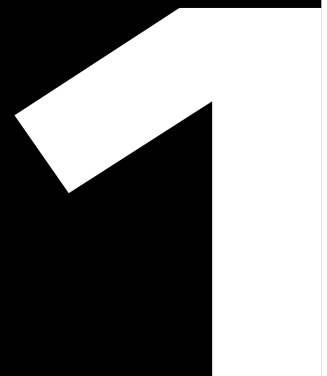

FIRE EXTINGUISHERS & CHEMICAL



For Offices, Warehouses, & More!



AX456



AX500

Amerex® ABC DRY CHEMICAL FIRE EXTINGUISHERS

use a monoammonium phosphate dry chemical to insulate Class A fires by melting and clinging to the heated surface. On Class B fires, they smother and break the chain reaction and are non-conductors of electricity. USCG approved with bracket listed on the UL label.

P/N	SHIP. WEIGHT	UNIT HEIGHT	UNIT WIDTH	SHELL DIAMETER	HEAVY-DUTY BRACKET P/N	FM APPROVED
AX417T	5.5 lb	15 ¹ / ₂ "	5 ³ / ₄ "	3"	—	Yes
AX500	9.25 lb	15 ¹ / ₄ "	7 ¹ / ₄ "	4 ¹ / ₄ "	5DC	Yes
AX500T	9.5 lb	15 ¹ / ₄ "	7 ¹ / ₄ "	4 ¹ / ₄ "	5DC	Yes
AX424	10.5 lb	15 ¹ / ₂ "	8"	4 ¹ / ₄ "	5DC	No
AX402	9.25 lb	15 ¹ / ₄ "	7 ¹ / ₄ "	4 ¹ / ₄ "	5DC	No
AX402T	9.5 lb	15 ¹ / ₄ "	7 ¹ / ₄ "	4 ¹ / ₄ "	5DC	No
AX456	18 lb	20"	7 ³ / ₄ "	5"	5HB	Yes
AX441	19 lb	20 ¹ / ₂ "	8 ³ / ₄ "	5"	5HB	No
AX411	38 lb	24"	10 ¹ / ₄ "	7"	15HB	Yes
AX423	39 lb	24"	10 ¹ / ₄ "	7"	15HB	Yes

P/N	DESCRIPTION	UL RATING
AX417T	2.5 lb ABC w/ Vehicle Bracket	1A:10B:C
AX500	5 lb ABC w/ Wall Hanger	2A:10B:C
AX500T	5 lb ABC w/ Vehicle Bracket	2A:10B:C
AX424	5 lb ABC w/ Brass Valve & Wall Hanger	2A:10B:C
AX402	5 lb ABC w/ Wall Hanger	3A:40B:C
AX402T	5 lb ABC w/ Vehicle Bracket	3A:40B:C
AX456	10 lb ABC w/ Wall Hanger	4A:80B:C
AX441	10 lb ABC w/ Brass Valve & Wall Hanger	4A:80B:C
AX411	20 lb ABC w/ Wall Hanger	10A:120B:C
AX423	20 lb ABC w/ Brass Valve & Wall Hanger	10A:120B:C

→ **More ABC DRY CHEMICAL FIRE EXTINGUISHERS Available - Call for Pricing**



AX403T



AX453

AMEREX® FIRE EXTINGUISHERS

Perfect for kitchens, garages, boats, and vehicles, **Amerex® BC DRY CHEMICAL FIRE EXTINGUISHERS** contain a siliconized sodium bicarbonate based dry chemical, making them suitable for combating flammable liquid and pressurized gas fires. They are electrically non-conductive, and the chemical, by nature, will not bake to hot surfaces, allowing for easy clean-up. USCG approved with bracket listed on the UL label.

P/N	SHIP. WEIGHT	UNIT HEIGHT	UNIT WIDTH	SHELL DIAMETER	HEAVY-DUTY BRACKET P/N	FM APPROVED
AX620T	2.5 lb	10"	3 ¹ / ₂ "	2 ⁵ / ₈ "	—	No
AX403T	5.5 lb	15 ¹ / ₂ "	5 ³ / ₄ "	3"	—	Yes
AX453	9.75 lb	15 ¹ / ₄ "	7 ¹ / ₄ "	4 ¹ / ₄ "	5DC	No
AX457	18 lb	20"	7 ³ / ₄ "	5"	5HB	Yes
AX412	38 lb	24"	10 ¹ / ₄ "	7"	15HB	Yes

P/N	DESCRIPTION	UL RATING
AX620T	1 lb BC w/ Vehicle Bracket	2B:C
AX403T	2.5 lb BC w/ Vehicle Bracket	10B:C
AX453	5.5 lb BC w/ Wall Hanger	40B:C
AX457	10 lb BC w/ Wall Hanger	60B:C
AX412	20 lb BC w/ Wall Hanger	120B:C

→ **More BC DRY CHEMICAL FIRE EXTINGUISHERS Available - Call for Pricing.**



AX457



AX412

Specially designed for commercial and industrial applications that handle, transport, process, or store large quantities of flammable liquids and gases, these **Amerex® HIGH FLOW PORTABLE FIRE EXTINGUISHERS** are the perfect choice, especially for spills on flat horizontal surfaces with combustible/non-combustible materials and potential obstacles to fighting a fire. They are made with the same hardware and valve components as **Amerex's** standard models but with twice the flow rate. USCG approved with bracket listed on the UL label.

P/N	SHIP. WEIGHT	UNIT HEIGHT	UNIT WIDTH	SHELL DIAMETER	HEAVY-DUTY BRACKET P/N
AX720	19 lb	20 ¹ / ₂ "	8 ³ / ₄ "	5"	5HB
AX760	39 lb	24"	10 ¹ / ₄ "	7"	15HB
AX722	19 lb	20 ¹ / ₂ "	8 ³ / ₄ "	5"	5HB
AX762	39 lb	24"	10 ¹ / ₄ "	7"	15HB

P/N	DESCRIPTION	UL RATING
AX720	10 lb ABC w/ Wall Hanger	1A:20B:C
AX760	20 lb ABC w/ Wall Hanger	4A:60B:C
AX722	10 lb PK w/ Wall Hanger	20B:C
AX762	20 lb PK w/ Wall Hanger	60B:C



Amerex® CHROME ABC and BC DRY CHEMICAL FIRE EXTINGUISHERS are chrome-plated steel cylinders. A great choice for homes, offices, and autos as well as recreational and off-road vehicles. USCG approved with bracket listed on the UL label except for **AX620TC**.

P/N	SHIP. WEIGHT	UNIT HEIGHT	UNIT WIDTH	SHELL DIAMETER	HEAVY-DUTY BRACKET P/N	FM APPROVED
AX620TC	2.5 lb	10"	3 ¹ / ₂ "	2 ⁷ / ₈ "	—	No
AX417TC	5.5 lb	15 ¹ / ₂ "	5 ³ / ₄ "	3"	—	Yes
AX500TC	9.5 lb	15 ¹ / ₄ "	7 ¹ / ₄ "	4 ¹ / ₄ "	5DC	Yes
AX456C	18 lb	20"	7 ³ / ₄ "	5"	5HB	Yes

P/N	DESCRIPTION	UL RATING
AX620TC	1 lb BC Chrome w/ Vehicle Bracket	2B:C
AX417TC	2.5 lb ABC Chrome w/ Vehicle/Marine Bracket	1A:10B:C
AX500TC	5 lb ABC Chrome w/ Vehicle/Marine Bracket	2A:10B:C
AX456C	10 lb ABC Chrome w/ Wall Hanger	4A:80B:C



Amerex® PURPLE K FIRE EXTINGUISHERS contain specially fluidized and silicized potassium bicarbonate dry chemical that is most effective on Class B flammable liquids and pressurized gases. They are electrically non-conductive and have long been the choice of oil, gas, chemical, and utilities companies. USCG approved with bracket listed on the UL label.

P/N	SHIP. WEIGHT	UNIT HEIGHT	UNIT WIDTH	SHELL DIAMETER	HEAVY-DUTY BRACKET P/N	FM APPROVED
AX479T	9.5 lb	15 ¹ / ₄ "	7 ¹ / ₄ "	4 ¹ / ₄ "	5DC	No
AX460	19 lb	20 ¹ / ₂ "	8 ³ / ₄ "	5"	5HB	Yes
AX413	38 lb	24"	10 ¹ / ₄ "	7"	15HB	Yes
AX415	39 lb	24"	10 ¹ / ₄ "	7"	15HB	Yes

P/N	DESCRIPTION	UL RATING
AX479T	5 lb PK w/ Vehicle Bracket	30B:C
AX460	10 lb PK w/ Brass Valve & Wall Hanger	80B:C
AX413	20 lb PK w/ Wall Hanger	120B:C
AX415	20 lb PK w/ Brass Valve & Wall Hanger	120B:C



1 FIRE EXTINGUISHERS & CHEMICAL



AX384T



AX385TS



AX386T

An environmentally safe replacement for Halon 1211, **Amerex® HALOTRON® I FIRE EXTINGUISHERS** contain a hydrochlorofluorocarbon (HCFC-123) blend agent that discharges as a rapidly evaporating liquid, leaving no residue. Pressurized with argon gas, the **Halotron I** agent is an EPA approved "clean agent" for Class A, B, and C hazards that will not conduct electricity back to the operator. Models **AX386T**, **DDPAX386TC**, **AX397**, and **AX398** are USCG approved with bracket listed on the UL label.

P/N	SHIP. WEIGHT	UNIT HEIGHT	UNIT WIDTH	SHELL DIAMETER	HEAVY-DUTY BRACKET P/N
AX384T	3.25 lb	10"	3 ¹ / ₂ "	2 ⁵ / ₈ "	—
AX385TS	5.25 lb	15 ¹ / ₂ "	6 ³ / ₈ "	3"	—
DDPAX385TSC	5.25 lb	15 ¹ / ₂ "	6 ³ / ₈ "	3"	—
AX386T	9.5 lb	15 ¹ / ₄ "	5 ³ / ₄ "	4 ¹ / ₄ "	5DC
DDPAX386TC	9.5 lb	15 ¹ / ₄ "	5 ³ / ₄ "	4 ¹ / ₄ "	5DC
AX397	22.5 lb	21 ⁷ / ₈ "	9 ¹ / ₄ "	6"	10HB
AX398	27.5 lb	21 ⁷ / ₈ "	9 ¹ / ₄ "	6"	10HB
DDPAX890	57 lb	27 ⁷ / ₈ "	8"	8"	—
DDPAX891	115 lb	37 ⁵ / ₈ "	9"	9"	—
DDPAX892	258 lb	39 ³ / ₄ "	14"	14"	—

P/N	DESCRIPTION	UL RATING
AX384T	1.4 lb Halotron I w/ Vehicle Bracket	1B:C
AX385TS	2.5 lb Halotron I w/ Vehicle Bracket	2B:C
DDPAX385TSC	2.5 lb Chrome Halotron I w/ Vehicle Bracket	2B:C
AX386T	5 lb w/ Halotron I Vehicle Bracket	5B:C
DDPAX386TC	5 lb Chrome Halotron I w/ Vehicle Bracket	5B:C
AX397	11 lb Halotron I w/ Wall Hanger	1A:10B:C
AX398	15.5 lb Halotron I w/ Wall Hanger	2A:10B:C
DDPAX890	35 lb Bulk Halotron I Cylinder	
DDPAX891	80 lb Bulk Halotron I Cylinder	
DDPAX892	200 lb Bulk Halotron I Cylinder	



AX397



AX398

Amerex® HALON 1211 FIRE EXTINGUISHERS feature solid-steel cylinders with all-metal valves and use all-recycled gas in accordance with the Montreal Protocol. Halon 1211 is a liquefied gas pressurized with nitrogen, which discharges as a vapor, causing no cold or static shock and no impairment of the operator's vision. This clean agent quickly penetrates difficult-to-see and hard-to-reach areas and leaves no residue. USCG approved with bracket listed on the UL label, except for models **DDPAX344T** and **DDPAX344TC**.

P/N	SHIP. WEIGHT	UNIT HEIGHT	UNIT WIDTH	SHELL DIAMETER	HEAVY-DUTY BRACKET P/N	FM APPROVED
DDPAX344T	2.75 lb	10"	3 ⁵ / ₈ "	2 ⁵ / ₈ "	—	No
DDPAX344TC	2.75 lb	10"	3 ⁵ / ₈ "	2 ⁵ / ₈ "	—	No
AX352TS	5.5 lb	14 ³ / ₈ "	4 ¹ / ₂ "	3"	—	No
DDPAX352TSC	5.5 lb	14 ³ / ₈ "	4 ¹ / ₂ "	3"	—	No
DDPAX355T	9.75 lb	15 ¹ / ₄ "	5 ³ / ₄ "	4 ¹ / ₄ "	5DC	No
DDPAX369	16.75 lb	16 ¹ / ₄ "	8 ¹ / ₂ "	5"	5HB	Yes
DDPAX371	22 lb	20 ¹ / ₄ "	8 ¹ / ₂ "	5"	5HB	Yes
DDPAX361	36.25 lb	24"	9 ³ / ₄ "	7"	15HB	Yes

P/N	DESCRIPTION	UL RATING
DDPAX344T	1.25 lb Halon w/ Vehicle Bracket	2B:C
DDPAX344TC	1.25 lb Chrome Halon w/ Vehicle Bracket	2B:C
AX352TS	2.5 lb Halon w/ Strap Bracket	5B:C
DDPAX352TSC	2.5 lb Chrome Halon w/ Strap Bracket	5B:C
DDPAX355T	5 lb Halon w/ Vehicle Bracket	10B:C
DDPAX369	9 lb Halon w/ Brass Valve & Wall Hanger	1A:10B:C
DDPAX371	13 lb Halon w/ Brass Valve & Wall Hanger	2A:40B:C
DDPAX361	17 lb Halon w/ Brass Valve & Wall Hanger	4A:80B:C



AX352TS



DDPAX361

Amerex® CARBON DIOXIDE (CO₂) PORTABLE FIRE EXTINGUISHERS effectively fight Class B flammable liquid fires and are electrically non-conductive with a clean, non-contaminating, and odorless gas. They are perfectly safe for use on clothing, equipment, valuable documents, and food. USCG approved with bracket listed on the UL label.

P/N	SHIP. WEIGHT	UNIT HEIGHT	UNIT WIDTH	SHELL DIAMETER	HEAVY-DUTY BRACKET P/N	FM APPROVED
AX322	13.1 lb	17 ³ / ₄ "	8 ¹ / ₄ "	5 ¹ / ₄ "	5HB	Yes
AX322NM	13.1 lb	17 ³ / ₄ "	8 ¹ / ₄ "	5 ¹ / ₄ "	-	Yes
AX330	28.25 lb	24"	12"	7"	15HB	Yes
AX331	37.75 lb	30"	12"	7"	15HB	Yes
AX332	50.75 lb	30"	13"	8"	20HB	Yes

P/N	DESCRIPTION	UL RATING
AX322	5 lb CO ₂ w/ Wall Hanger	5B:C
AX322NM	5 lb Non-Magnetic CO ₂ w/ Wall Hanger	5B:C
AX330	10 lb CO ₂ w/ Wall Hanger	10B:C
AX331	15 lb CO ₂ w/ Wall Hanger	10B:C
AX332	20 lb CO ₂ w/ Wall Hanger	10B:C



AX322



AX322NM

Amerex® HIGH-PERFORMANCE DRY CHEMICAL FIRE EXTINGUISHERS feature superior vertical and horizontal range with a high 240 psi operating pressure. Select **Fast Flow** models offer high flow rates, fast discharge, quicker knockdown, and increased operator protection. Select **Compliance Flow** models offer longer range and higher UL ratings. Cylinders are made of painted galvanized drawn steel with protective rubber foot rings and feature all-metal valve construction and gauge guards. Extinguishers come with a standard wall bracket and a 12-year warranty. USCG approved with bracket listed on the UL label.

P/N	SHIP. WEIGHT	UNIT HEIGHT	UNIT WIDTH	SHELL DIAMETER	HEAVY-DUTY BRACKET P/N
DDPAX594	31 lb	17 ¹ / ₂ "	10 ¹ / ₂ "	7"	15HB
AX581	43 lb	24 ³ / ₄ "	10 ¹ / ₂ "	7"	15HB
AX567	58 lb	26 ¹ / ₂ "	11"	8"	20HB
DDPAX592	31 lb	17 ¹ / ₂ "	10 ¹ / ₂ "	7"	15HB
AX564	43 lb	24 ³ / ₄ "	10 ¹ / ₂ "	7"	15HB
AX589	58 lb	26 ¹ / ₂ "	11"	8"	20HB
DDPAX582	43 lb	24 ³ / ₄ "	10 ¹ / ₂ "	7"	15HB
DDPAX568	58 lb	26 ¹ / ₂ "	11"	8"	20HB
DDPAX595	31 lb	17 ¹ / ₂ "	10 ¹ / ₂ "	7"	15HB
AX580	43 lb	24 ³ / ₄ "	10 ¹ / ₂ "	7"	15HB
DDPAX584	43 lb	24 ³ / ₄ "	10 ¹ / ₂ "	7"	15HB
AX569	58 lb	26 ¹ / ₂ "	11"	8"	20HB
DDPAX599	31 lb	17 ¹ / ₂ "	10 ¹ / ₂ "	7"	15HB
DDPAX566	43 lb	24 ³ / ₄ "	10 ¹ / ₂ "	7"	15HB
AX591	58 lb	26 ¹ / ₂ "	11"	8"	20HB

P/N	DESCRIPTION	UL RATING
DDPAX594	13.2 lb ABC Fast Flow	2A:40B:C
AX581	20 lb ABC Fast Flow	4A:40B:C
AX567	30 lb ABC Fast Flow	4A:40B:C
DDPAX592	13.2 lb ABC Compliance Flow	4A:80B:C
AX564	20 lb ABC Compliance Flow	10A:120B:C
AX589	30 lb ABC Compliance Flow	10A:160B:C
DDPAX582	20 lb BC Fast Flow	40B:C
DDPAX568	30 lb BC Fast Flow	40B:C
DDPAX595	13.2 lb PK Fast Flow	40B:C
AX580	20 lb PK Fast Flow	40B:C
DDPAX584	20 lb PK Fast Flow	20B:C
AX569	30 lb PK Fast Flow	40B:C
DDPAX599	13.2 lb PK Compliance Flow	80B:C
DDPAX566	20 lb PK Compliance Flow	120B:C
AX591	30 lb PK Compliance Flow	160B:C



DDPAX599, DDPAX568, AX567

1 FIRE EXTINGUISHERS & CHEMICAL



AX570

RP257

Designed ideally for use on combustible metal fires, **Amerex® CLASS D DRY POWDER FIRE EXTINGUISHERS** are fitted with a “soft-flow” extension applicator to keep operators away from extreme heat and toxic fumes caused by burning material. The applicator can be quickly removed (to provide a straight stream of chemical) when greater range, a narrow discharge pattern, or a lobbing effect is required. Comes with a special corrosion-resistant yellow (Class D) color-coded paint finish. FM approved.

P/N	SHIP. WEIGHT	UNIT HEIGHT	UNIT WIDTH	SHELL DIAMETER	HEAVY-DUTY BRACKET P/N
AX570	53 lb	35"	13"	8"	20HB
DDPAX571	53 lb	35"	13"	8"	20HB

P/N	DESCRIPTION
AX570	30 lb Sodium Chloride w/ Wall Hanger
DDPAX571	30 lb Copper w/ Wall Hanger

P/N	DESCRIPTION
RP257	Class D Sign, “For Use On Combustible Metals Only”, 7" x 10"

Amerex® Class K “Kitchen Use” WET CHEMICAL FIRE EXTINGUISHERS contain a special potassium acetate based low-pH agent, developed for use with pre-engineered restaurant kitchen systems (included in NFPA 10). Units come fully charged. USCG approved with bracket listed on the UL label.

P/N	SHIP. WEIGHT	UNIT HEIGHT	UNIT WIDTH	SHELL DIAMETER	HEAVY-DUTY BRACKET P/N
AX260	22.5 lb	19"	9"	7"	15HB
DDPAX260CG	22.5 lb	19"	9"	7"	AX810CG
AX262	33.5 lb	24½"	9"	7"	15HB
DDPAX262CG	33.5 lb	24½"	9"	7"	AX810CG

P/N	DESCRIPTION	UL RATING
AX260	6 L Wet Chem w/ Wall Hanger	2A:K
DDPAX260CG	6 L Wet Chem w/ Wall Hanger	2A:K
AX262	2.5 gal Wet Chem w/ Wall Hanger	2A:K
DDPAX262CG	2.5 gal Wet Chem w/ Wall Hanger	2A:K
AX5302	Recharge, 6 L Wet Chem, Pkg/2 For AX260	
AX660	Recharge, 2.5 gal Wet Chem, Pkg/2 For AX262	
BL189	K-Class “Fire Extinguisher” Arrow Sign, 8" x 12"	
AX810CG	Amerex Heavy-Duty Bracket (Galvanized)	



AX260, AX262

Amerex's STORED PRESSURE WATER FIRE EXTINGUISHER utilizes the cooling, soaking, and penetrating effect of a 45'–55' stream of water. For use on Class A fires. **Amerex® FOAM FIRE EXTINGUISHERS** are for Class A and B fires and offer easy, effective application, thanks to their air-aspirated nozzles. Ideal for emergency first response vehicles.

NOTE: Units ship empty.

P/N	SHIP. WEIGHT	UNIT HEIGHT	UNIT WIDTH	SHELL DIAMETER	HEAVY-DUTY BRACKET P/N	FM APPROVED
AX240	7.5 lb	24½"	9"	7"	15HB	Yes
AX250	11 lb	24½"	9"	7"	15HB	Yes
AX254	7.5 lb	19"	8"	7"	15HB	No

P/N	DESCRIPTION	UL RATING
AX240	2.5 gal Water w/ Wall Hanger	2A
AX250	2.5 gal AFFF w/ Wall Hanger	3A:20B
AX254	6 L AFFF w/ Wall Hanger	2A:10B
AX506B2	Antifreeze Charge, Pkg/2 For 2.5 gal Loaded Stream Extinguishers, Model 240	
AX502AR	23 oz AR-AFFF Premix Charge For 2.5 gal & 6 L Extg, Models 250, 252, 254, 250CG	



AX240

Amerex® AFFF PORTABLE FOAM FIRE EXTINGUISHER

is for use on Class A and Class B fires. Features easy and effective application using the hose and air-aspirating nozzle. FM approved. USCG approved with bracket listed on the UL label.

P/N	SHIP. WEIGHT	UNIT HEIGHT	UNIT WIDTH	SHELL DIAMETER	HEAVY-DUTY BRACKET P/N
AX250CG	11 lb	24½"	9"	7"	AX810CG

P/N	DESCRIPTION	UL RATING
AX250CG	2.5 gal AFFF w/ Wall Hanger	3A:20B
AX810CG	Amerex Heavy-Duty Bracket (Galvanized)	
AX502AR	23 oz AR-AFFF Premix Charge For 2.5 gal & 6 L Extg, Models 250, 252, 254, 250CG	

Amerex® NON-MAGNETIC STORED PRESSURE DE-IONIZED WATER MIST FIRE EXTINGUISHERS

are the ultimate for Class A fires where potential Class C (electrical) hazards exist. The fine spray produced from their unique misting nozzle provides protection against electrical shock, greatly enhances the cooling and soaking characteristics of the agent, and reduces scattering of burning materials. Perfect for hospital environments, telecommunication facilities, and "clean room" manufacturing facilities.

NOTE: Units ship empty.

P/N	SHIP. WEIGHT	UNIT HEIGHT	UNIT WIDTH	SHELL DIAMETER	HEAVY-DUTY BRACKET P/N
AX270NM	7 lb	24½"	11"	7"	15HB
AX272NM	8 lb	27½"	11"	7"	15HB

P/N	DESCRIPTION	UL RATING
AX270NM	1.75 gal De-Ionized Water w/ Wall Hanger	2A:C
AX272NM	2.5 gal De-Ionized Water w/ Wall Hanger	2A:C
AX6702	1.75 gal De-Ionized Water Charge, Pkg/2	
AX6712	2.5 gal De-Ionized Water Charge, Pkg/2	

Amerex's HEAVY-DUTY DOLLY CART moves larger, heavier extinguishers with ease. Fits cylinders 7"-8" in diameter.

P/N	DESCRIPTION
859A	Heavy-Duty Dolly Cart

Amerex® REGULATED PRESSURE WHEELED FIRE EXTINGUISHERS

feature a 110 cu ft nitrogen cylinder with a pressure regulator and 16" semi-pneumatic rubber tires. Their traditional design allows for adequate pressure to ensure a smooth, complete discharge of the dry chemical with a pressure reserve for blowing down the discharge hose. Easy to transport and operate by one person. USCG approved. Call the Sales Department for quantity pricing.

P/N	SHIP. WEIGHT	UNIT HEIGHT	UNIT WIDTH	UNIT DEPTH	FM APPROVED
DDPAX467	404 lb	52"	26"	38"	No
DDPAX469	404 lb	52"	26"	38"	Yes
DDPAX468	429 lb	52"	26"	38"	No

P/N	DESCRIPTION	UL RATING
DDPAX467	125 lb Regulated Pressure ABC	30A:240B:C
DDPAX469	125 lb Regulated Pressure PK	320B:C
DDPAX468	150 lb Regulated Pressure BC	240B:C



AX250CG



AX270NM, AX272NM



859A



DDPAX467

1 FIRE EXTINGUISHERS & CHEMICAL



DDPAX470

Amerex® REGULATED PRESSURE WHEELED FIRE EXTINGUISHERS feature a 110 cu ft nitrogen cylinder with a pressure regulator and 2½" x 36" steel wheels. This traditional design allows for adequate pressure to ensure a smooth, complete discharge of the dry chemical with a pressure reserve for blowing down the discharge hose. Easy to transport and operate by one person. USCG approved. Call the Sales Department for quantity pricing.

P/N	SHIP. WEIGHT	UNIT HEIGHT	UNIT WIDTH	UNIT DEPTH	FM APPROVED
DDPAX470	432 lb	52"	28"	45"	No
DDPAX472	432 lb	52"	28"	45"	Yes
DDPAX471	457 lb	52"	28"	45"	No

P/N	DESCRIPTION	UL RATING
DDPAX470	125 lb Regulated Pressure ABC	30A:240B:C
DDPAX472	125 lb Regulated Pressure PK	320B:C
DDPAX471	150 lb Regulated Pressure BC	240B:C



AX450

Amerex® DIRECT PRESSURE WHEELED FIRE EXTINGUISHERS utilize a 23 cu ft nitrogen cylinder on 125 lb and 150 lb units and a 55 cu ft nitrogen cylinder on 300 lb and 350 lb units with a "quick opening valve" to pressurize and completely discharge the agent cylinder. The 125 lb and 150 lb units have 16" semi-pneumatic tires. The 300 lb and 350 lb units have 6" x 36" steel wheels. Both allow for easy maneuvering and operation by one person. All units are fitted with a 4" stainless steel fill opening and brass cap for easy servicing. USCG approved. Call the Sales Department for quantity pricing.

P/N	SHIP. WEIGHT	UNIT HEIGHT	UNIT WIDTH	UNIT DEPTH	FM APPROVED
AX450	335 lb	45"	24"	36"	No
DDPAX451	360 lb	45"	24"	36"	No
AX452	335 lb	45"	24"	36"	Yes
DDPAX491	743 lb	57"	34"	39"	No
DDPAX492	793 lb	57"	34"	39"	No
AX493	743 lb	57"	34"	39"	Yes

P/N	DESCRIPTION	UL RATING
AX450	125 lb Direct Pressure ABC	30A:240B:C
DDPAX451	150 lb Direct Pressure BC	240B:C
AX452	125 lb Direct Pressure PK	320B:C
DDPAX491	300 lb Direct Pressure ABC	40A:320B:C
DDPAX492	350 lb Direct Pressure BC	320B:C
AX493	300 lb Direct Pressure PK	320B:C



DDPAX491

Amerex® STORED PRESSURE WHEELED FIRE EXTINGUISHERS feature cage-type protection for the agent cylinder and a balanced platform for transportation and operation. The narrow width and semi-pneumatic rubber tires allow for single-person operation in confined areas. Chemical and pressure are sealed in the agent cylinder. USCG approved. Call the Sales Department for quantity pricing.

P/N	SHIP. WEIGHT	UNIT HEIGHT	UNIT WIDTH	UNIT DEPTH
AX495	174 lb	46"	21 1/2"	24"
DDPAX496	174 lb	46"	21 1/2"	24"
DDPAX497	174 lb	46"	21 1/2"	24"
AX488	344 lb	53 1/2"	28"	40"
DDPAX490	344 lb	53 1/2"	28"	40"
DDPAX489	369 lb	53 1/2"	28"	40"

P/N	DESCRIPTION	UL RATING
AX495	50 lb Stored Pressure ABC	20A:160B:C
DDPAX496	50 lb Stored Pressure BC	160B:C
DDPAX497	50 lb Stored Pressure PK	160B:C
AX488	125 lb Stored Pressure ABC	30A:240B:C
DDPAX490	125 lb Stored Pressure PK	320B:C
DDPAX489	150 lb Stored Pressure BC	240B:C

→ **More STORED PRESSURE WHEELED FIRE EXTINGUISHERS Available - Call for Pricing.**

Amerex® WHEELED HALOTRON® I FIRE EXTINGUISHERS feature the same qualities found in all **Amerex®** products and add the convenience of a clean extinguishing agent with a low GWP (Global Warming Potential) and a low ODP (Ozone Depletion Potential). **Halotron I** has a short atmospheric lifetime, and each unit maximizes agent visibility during discharge. There is no thermal shock, static shock, or electrical conductivity back to the operator. EPA approved clean agent for Class A, B, and C hazards as well as FAA approved for both ramp use (ARFF vehicle) and on-board an aircraft. Call the Sales Department for quantity pricing.

P/N	SHIP. WEIGHT	UNIT HEIGHT	UNIT WIDTH	UNIT DEPTH
DDPAX673	286 lb	58"	28"	39"
DDPAX674	512 lb	64"	30"	42"
DDPAX675	610 lb	64"	37"	43"

P/N	DESCRIPTION	UL RATING
DDPAX673	65 lb Halotron I w/ Semi-Pneumatic Wheels	4A:80B:C
DDPAX674	150 lb Halotron I w/ Semi-Pneumatic Wheels	10A:120B:C
DDPAX675	150 lb Halotron I w/ Steel Wheels	10A:120B:C



AX488



DDPAX673



DDPAX675

1 FIRE EXTINGUISHERS & CHEMICAL



DDPAX630

Amerex's AR-AFFF WHEELED FIRE EXTINGUISHER

contains a premixed alcohol-resistant foam that is highly effective on Class B fuel fires and a penetrating/wetting agent on fires involving Class A materials. Unit features quality hardware throughout, including a unique agent cylinder fabricated entirely of stainless steel—no interior coatings are necessary. Meets NFPA requirements for hospital helicopter pad protection. USCG approved. Call the Sales Department for quantity pricing.

P/N	SHIP. WEIGHT	UNIT HEIGHT	UNIT WIDTH	UNIT DEPTH
DDPAX630	390 lb	57"	34"	39"

P/N	DESCRIPTION	UL RATING
DDPAX630	33 gal Direct Pressure AR-AFFF	20A:160B
DDPAX534	2 gal AR-AFFF Recharge For Model 630	



DDPAX681

Amerex® CLASS D WHEELED FIRE EXTINGUISHERS

are ideal for large combustible metal fires. They are well balanced for quick transport, thanks to 36" non-sparking rubber-treaded steel wheels. Both extinguishers are pressurized with argon and regulated to a low 125 psi (to avoid disrupting the burning materials). FM approved. Call the Sales Department for quantity pricing.

P/N	SHIP. WEIGHT	UNIT HEIGHT	UNIT WIDTH	UNIT DEPTH
DDPAX680	444 lb	52"	28"	45"
DDPAX681	544 lb	52"	28"	45"

P/N	DESCRIPTION
DDPAX680	150 lb Regulated Pressure (Sodium Chloride)
DDPAX681	250 lb Regulated Pressure (Copper Powder)



AX333

Amerex® CARBON DIOXIDE (CO₂) WHEELED FIRE EXTINGUISHERS

are easy to operate with "quick opening" T-handle valves and horn-mounted shutoff valves. A logical choice where a Class B:C non-contaminating agent is required or where hand portable protection or the number of personnel would not be adequate. USCG approved. Call the Sales Department for quantity pricing.

P/N	SHIP. WEIGHT	UNIT HEIGHT	UNIT WIDTH	UNIT DEPTH
AX333	257 lb	47"	23"	48"
AX334	461 lb	47"	23"	48"

P/N	DESCRIPTION	UL RATING
AX333	50 lb CO ₂	20B:C
AX334	100 lb CO ₂	20B:C

NOTE: All prices quoted are FOB factory unless shipped from stock. All nitrogen cylinder operated wheeled extinguishers are shipped with the "DRY CHEMICAL" agent in pails. Most wheeled units are available in a stationary configuration. Inquire about special quantity pricing.

Square Thread Design Means Faster Valve Removal

Badger™ ADVANTAGE MULTI-PURPOSE FIRE EXTINGUISHERS are made to handle easier and be recharged quicker, thanks to a larger neck opening. The square thread design allows the valve to be removed and installed quickly. Heavy-duty plated steel siphon tubes are threaded for a more secure connection, and the polymer hose strap will not scratch the cylinder. Larger pull pin and handles are easy to operate—even with work gloves.

P/N	SHIP. WEIGHT	UNIT HEIGHT	UNIT WIDTH	SHELL DIAMETER	HEAVY-DUTY BRACKET P/N
21007865B	5 lb	15"	5½"	3¼"	-
21007866B	9.5 lb	16 ⁷ / ₁₆ "	7½"	4½"	5DC
21008936B	9.5 lb	16 ⁷ / ₁₆ "	7½"	4½"	5DC
21007867B	17.5 lb	19 ⁵ / ₈ "	8"	5¼"	5HB
21007868B	31.5 lb	21 ¹¹ / ₁₆ "	9"	7½"	15HBL

P/N	DESCRIPTION	UL RATING
21007865B	2.5 lb Advantage w/ Vehicle Bracket	1A:10B:C
21007866B	5 lb Advantage w/ Wall Hook	3A:40B:C
21008936B	5 lb Advantage w/ Vehicle Bracket	3A:40B:C
21007867B	10 lb Advantage w/ Wall Hook	4A:60B:C
21007868B	20 lb Advantage w/ Wall Hook	6A:80B:C



BADGER™ FIRE EXTINGUISHERS

Badger™ STANDARD and EXTRA MULTI-PURPOSE FIRE EXTINGUISHERS tackle the majority of fire risks found in most commercial, industrial, and domestic environments. They are suitable for use on Class A, B, and C fires and mount on any surface with the wall hook supplied or, if preferred, they can be supplied with an optional vehicle bracket. USCG approved with bracket listed on the UL label.

P/N	SHIP. WEIGHT	UNIT HEIGHT	UNIT WIDTH	SHELL DIAMETER	HEAVY-DUTY BRACKET P/N
22430B	5.4 lb	14 ⁷ / ₈ "	5½"	3"	-
23384B	5.8 lb	14 ⁷ / ₈ "	5½"	3"	-
22435B	10 lb	15 ¹ / ₄ "	7¼"	4¼"	5DC
22486B	10 lb	15 ¹ / ₄ "	7¼"	4¼"	5DC
23390B	10.4 lb	15 ¹ / ₄ "	7½"	4¼"	5DC
23463B	10.4 lb	15 ¹ / ₄ "	7¼"	4¼"	5DC
22603B	17 lb	18 ⁵ / ₁₆ "	7¾"	5¼"	5HB
23396B	18 lb	18 ⁵ / ₁₆ "	7¾"	5¼"	5HB
22682B	33 lb	21 ¹ / ₈ "	9¼"	7¼"	15HBL
23497B	33 lb	21 ¹ / ₈ "	9¼"	7¼"	15HBL

P/N	DESCRIPTION	UL RATING
22430B	Standard 2.5 lb ABC w/ Vehicle Brkt	1A:10B:C
23384B	Extra 2.5 lb ABC w/ Brass Valve & Vehicle Bracket	1A:10B:C
22435B	Standard 5 lb ABC w/ Wall Hook	3A:40B:C
22486B	Standard 5 lb ABC w/ Vehicle Brkt	3A:40B:C
23390B	Extra 5 lb ABC w/ Brass Valve & Wall Hook	3A:40B:C
23463B	Extra 5 lb ABC w/ Brass Valve & Vehicle Bracket	3A:40B:C
22603B	Standard 10 lb ABC w/ Wall Hook	4A:80B:C
23396B	Extra 10 lb ABC w/ Brass Valve & Wall Hook	4A:80B:C
22682B	Standard 20 lb ABC w/ Wall Hook	6A:120B:C
23497B	Extra 20 lb ABC w/ Brass Valve & Wall Hook	6A:120B:C



1 FIRE EXTINGUISHERS & CHEMICAL



23476B

Badger™ EXTRA REGULAR DRY CHEMICAL STORED PRESSURE FIRE EXTINGUISHERS

are specifically designed to meet the needs of industrial and commercial premises where there is a flammable liquid risk. Suitable for use on Class B and C fires, they are cost effective to maintain, offer good value and excellent performance, and mount on any surface with a wall hook, forked hanger, or an optional vehicle bracket. Brass valves standard. USCG approved with bracket listed on the UL label.

P/N	SHIP. WEIGHT	UNIT HEIGHT	UNIT WIDTH	SHELL DIAMETER	HEAVY-DUTY BRACKET P/N
23471B	5.4 lb	14 ⁷ / ₈ "	5 ¹ / ₂ "	3"	-
23476B	10.4 lb	15 ¹ / ₄ "	7 ¹ / ₄ "	4 ¹ / ₄ "	5DC
23781B	18 lb	19 ¹ / ₈ "	8 ¹ / ₈ "	5 ¹ / ₄ "	5HB
23482B	33 lb	21 ¹ / ₈ "	9 ¹ / ₄ "	7 ¹ / ₄ "	15HBL

P/N	DESCRIPTION	UL RATING
23471B	2.75 lb BC w/ Vehicle Bracket	10B:C
23476B	5.5 lb BC w/ Wall Hook	40B:C
23781B	10 lb BC w/ Wall Hook	60B:C
23482B	20 lb BC w/ Wall Hook	120B:C



23488B



23778B

Badger™ EXTRA PURPLE K DRY CHEMICAL STORED PRESSURE FIRE EXTINGUISHERS

are designed for use on high-hazard types of Class B and C fires and come with brass valves. Purple K is generally superior to other dry chemicals on Class B fires, making these extinguishers ideal for use on industrial and commercial premises where flammable liquid or gas fire risks exist. USCG approved with bracket listed on the UL label.

P/N	SHIP. WEIGHT	UNIT HEIGHT	UNIT WIDTH	SHELL DIAMETER	HEAVY-DUTY BRACKET P/N
23485B	5.8 lb	14 ⁷ / ₈ "	5 ¹ / ₂ "	3"	-
23488B	10.4 lb	15 ¹ / ₄ "	7 ¹ / ₄ "	4 ¹ / ₄ "	5DC
23778B	17 lb	18 ⁷ / ₈ "	7 ³ / ₄ "	5 ¹ / ₄ "	5HB
23495B	32 lb	21 ¹ / ₈ "	9 ¹ / ₄ "	7 ¹ / ₄ "	15HBL

P/N	DESCRIPTION	UL RATING
23485B	2.5 lb PK w/ Vehicle Bracket	10B:C
23488B	5 lb PK w/ Wall Hook	30B:C
23778B	10 lb PK w/ Wall Hook	80B:C
23495B	20 lb PK w/ Wall Hook	120B:C

Offering the ultimate protection against Class B hazards,

Badger™ EXTRA HIGH FLOW DRY CHEMICAL FIRE EXTINGUISHERS

feature a steel cylinder, internal siphon tube, and heavy-duty chrome-plated brass valve. These models, available in ABC and Purple K, have dry chemical agent discharge rates exceeding the minimum one-pound-per-second recommendation of NFPA for pressure, three dimensional, and obstacle fires. USCG approved with bracket listed on the UL label.

P/N	SHIP. WEIGHT	UNIT HEIGHT	UNIT WIDTH	SHELL DIAMETER	HEAVY-DUTY BRACKET P/N
21006158B	18 lb	19 ¹ / ₈ "	8 ¹ / ₈ "	5 ¹ / ₄ "	5HB
21006160B	33 lb	21 ¹ / ₈ "	9 ¹ / ₄ "	7 ¹ / ₄ "	15HBL
21006159B	18 lb	19 ¹ / ₈ "	8 ¹ / ₈ "	5 ¹ / ₄ "	5HB
21006161B	33 lb	21 ¹ / ₈ "	9 ¹ / ₄ "	7 ¹ / ₄ "	15HBL

P/N	DESCRIPTION	UL RATING
21006158B	10 lb ABC w/ Wall Hook	1A:20B:C
21006160B	20 lb ABC w/ Wall Hook	4A:60B:C
21006159B	10 lb PK w/ Wall Hook	20B:C
21006161B	20 lb PK w/ Wall Hook	60B:C



21006158B

Badger™ EXTRA HALOTRON® I FIRE EXTINGUISHERS

are an environmentally acceptable Halon alternative and designed to meet any special hazard where Halon 1211 was specified and used.

Halotron I is ideal for protecting office computer areas, data storage, telecommunications, and high-tech clean rooms. **Halotron I** is the government specified clean agent alternative and is USCG approved with the bracket listed on the UL label, except for model **24563B**. Equipped with brass valves.

P/N	SHIP. WEIGHT	UNIT HEIGHT	UNIT WIDTH	SHELL DIAMETER	HEAVY-DUTY BRACKET P/N
24563B	6.9 lb	14 ⁷ / ₈ "	6 ¹ / ₈ "	3"	-
24567B	10.6 lb	15 ¹ / ₄ "	6 ¹ / ₈ "	4 ¹ / ₄ "	5DC
23082B	23 lb	16 ³ / ₁₆ "	8 ³ / ₈ "	7 ¹ / ₄ "	15HBL
23097B	26.5 lb	17 ¹ / ₈ "	8 ³ / ₄ "	7 ¹ / ₄ "	15HBL

P/N	DESCRIPTION	UL RATING
24563B	2.5 lb Halotron I w/ Vehicle Bracket	2B:C
24567B	5 lb Halotron I w/ Wall Hook	5B:C
23082B	11 lb Halotron I w/ Wall Hook	1A:10B:C
23097B	15.5 lb Halotron I w/ Wall Hook	2A:10B:C



Badger™ EXTRA CARBON DIOXIDE (CO₂) FIRE EXTINGUISHERS

offer fast, safe, and effective protection against fires involving electrical equipment and flammable liquids. They are generally suited for use indoors, making them ideal for today's office environments. The cylinders are manufactured from lightweight, high-grade aluminum with brass valves. They are highly effective, easy to use, and leave no messy residue to clean up. USCG approved with bracket listed on the UL label, except for **25078B**.

P/N	SHIP. WEIGHT	UNIT HEIGHT	UNIT WIDTH	SHELL DIAMETER	HEAVY-DUTY BRACKET P/N
21111B	15 lb	17"	8 ¹ / ₂ "	5 ¹ / ₄ "	5HB
21106B	30 lb	19 ⁵ / ₁₆ "	10 ¹⁵ / ₁₆ "	6 ¹⁵ / ₁₆ "	15HB
21103B	40 lb	26"	10 ¹³ / ₁₆ "	6 ¹³ / ₁₆ "	15HB
21096B	51 lb	26"	12"	8"	20HB
25078B	15 lb	17"	8 ¹ / ₂ "	5 ¹ / ₄ "	-

P/N	DESCRIPTION	UL RATING
21111B	5 lb CO ₂ w/ Wall Hook	5B:C
21106B	10 lb CO ₂ w/ Wall Hook	10B:C
21103B	15 lb CO ₂ w/ Wall Hook	10B:C
21096B	20 lb CO ₂ w/ Wall Hook	10B:C
25078B	5 lb CO ₂ w/ Non-Magnetic Bracket	5B:C



Badger™ EXTRA UNIVERSAL ULTRA AR-AFFF FOAM FIRE EXTINGUISHER

is effective on Class A common combustibles as well as both hydrocarbon and polar solvent types of Class B flammable liquids, so it eliminates the application guesswork associated with other foams. The unique synthetic base of **Universal Ultra AR-AFFF Foam** does not have any offensive odors, is non-toxic, environmentally friendly, biodegradable, and extremely simple to use and clean up. Brass valve standard.

NOTE: Ships empty.

P/N	SHIP. WEIGHT	UNIT HEIGHT	UNIT WIDTH	SHELL DIAMETER	HEAVY-DUTY BRACKET P/N
23697B	12 lb	24 ¹ / ₂ "	8 ³ / ₄ "	7"	15HB

P/N	DESCRIPTION	UL RATING
23697B	2.5 gal Foam w/ Wall Hook	1A:30B
23691B	6 L Recharge	
23702B	2.5 gal Recharge	



24563B

23082B

21111B

25078B

23697B

1 FIRE EXTINGUISHERS & CHEMICAL



25064B

The firefighting power and user-friendly design of **Badger™ EXTRA CLASS K PORTABLE FIRE EXTINGUISHERS** make them the ideal choice for commercial restaurant applications. These stored pressure extinguishers have been designed to offer the very best portable fire protection available in supplementing pre-engineered restaurant suppression systems. Units come with brass valves.

NOTE: 23171B ships empty.

P/N	SHIP. WEIGHT	UNIT HEIGHT	UNIT WIDTH	SHELL DIAMETER	HEAVY-DUTY BRACKET P/N
25064B	15 lb	19 ¹ / ₂ "	8 ³ / ₄ "	7"	15HB
23171B	19 lb	24 ¹ / ₂ "	8 ³ / ₄ "	7"	15HB

P/N	DESCRIPTION	UL RATING
25064B	6 L Wet Chemical w/ Wall Hook	K
23171B	2.5 gal Wet Chemical w/ Wall Hook	K
AC100	6 L Recharge Jug, Pkg/2	
AC250	2.5 gal Recharge	



DDP466521B



16888B

Badger™ EXTRA STORED PRESSURE WATER FIRE EXTINGUISHER is ideal for common combustibles materials, such as trash, wood, and paper. **Badger's** non-toxic, ozone-friendly pressurized water fire extinguisher is an excellent choice for virtually all Class A-type hazards. Brass valve standard.

NOTE: Ships empty.

P/N	SHIP. WEIGHT	UNIT HEIGHT	UNIT WIDTH	SHELL DIAMETER	HEAVY-DUTY BRACKET P/N
16888B	8 lb	24 ³ / ₄ "	8 ³ / ₄ "	7"	15HB

P/N	DESCRIPTION	UL RATING
16888B	2.5 gal Water w/ Wall Hook	2A
792B	WP-61 Antifreeze Charge	

Badger™ BRIGADE CARBON DIOXIDE (CO₂) CARTRIDGE OPERATED FIRE EXTINGUISHERS

are the industry's most effective fire extinguishers of their kind. Available in ABC, BC, or Purple K, these units use carbon dioxide expellant gas and feature deep-drawn seamless steel construction with corrosion-resistant cylinders for maximum performance. USCG approved with bracket listed on the UL label. For use down to -40°F.

P/N	SHIP. WEIGHT	UNIT HEIGHT	UNIT WIDTH	SHELL DIAMETER	HEAVY DUTY BRACKET P/N
DDP466521B	25.5 lb	18 ¹ / ₄ "	9 ¹ / ₂ "	5 ¹ / ₈ "	466541B
DDP466523B	25.5 lb	18 ¹ / ₄ "	9 ¹ / ₂ "	5 ¹ / ₈ "	466541B
466527B	45.5 lb	23 ³ / ₈ "	11 ¹ / ₄ "	6 ¹ / ₄ "	466542B
DDP466564B	45.5 lb	23 ³ / ₈ "	11 ¹ / ₄ "	6 ¹ / ₄ "	466542B
466528B	47.5 lb	23 ³ / ₈ "	11 ¹ / ₄ "	6 ¹ / ₄ "	466542B
466529B	46.5 lb	23 ³ / ₈ "	11 ¹ / ₄ "	6 ¹ / ₄ "	466542B
466533B	51 lb	23 ³ / ₈ "	12 ¹ / ₄ "	7 ³ / ₁₆ "	466543B
466539B	55 lb	23 ³ / ₈ "	12 ¹ / ₄ "	7 ³ / ₁₆ "	466543B
466534B	54.5 lb	23 ³ / ₈ "	12 ¹ / ₄ "	7 ³ / ₁₆ "	466543B

P/N	DESCRIPTION	UL RATING
DDP466521B	10.65 lb ABC w/ Wall Hook	4A:40B:C
DDP466523B	10.5 lb PK w/ Wall Hook	60B:C
466527B	21 lb ABC w/ Wall Hook	10A:60B:C
DDP466564B	21 lb ABC High Flow w/ Wall Hook	2A:40B:C
466528B	23 lb BC w/ Wall Hook	60B:C
466529B	22 lb PK w/ Wall Hook	80B:C
466533B	25 lb ABC w/ Wall Hook	10A:80B:C
466539B	29 lb BC w/ Wall Hook	120B:C
466534B	28.5 lb PK w/ Wall Hook	120B:C



466527B



466533B

When high-hazard fires demand a fast one-person response and exceptional performance, look to **Badger™ WHEELED STORED PRESSURE DRY CHEMICAL FIRE EXTINGUISHERS** to make it possible. Their long-range discharge offers control over ordinarily out-of-reach fires, allowing the operator to keep a safe distance from the fire source and smoke. The 50 lb unit provides cost-effective, reliable fire protection. USCG approved. All feature brass valves.

P/N	SHIP. WEIGHT	UNIT HEIGHT	UNIT WIDTH	UNIT DEPTH
20127B	140 lb	46 ¹ / ₄ "	23"	23"
20180B	140 lb	46 ¹ / ₄ "	23"	23"
20653B	300 lb	58"	28"	39 ¹ / ₄ "
20684B	300 lb	58"	28"	39 ¹ / ₄ "
DDP20677B	375 lb	58"	28"	39 ¹ / ₄ "

P/N	DESCRIPTION	UL RATING
20127B	50 lb ABC	20A:160B:C
20180B	50 lb PK	160B:C
20653B	125 lb ABC	40A:240B:C
20684B	125 lb PK	240B:C
DDP20677B	150 lb BC	240B:C



Badger™ WHEELED REGULATED RELEASE DRY CHEMICAL FIRE EXTINGUISHERS are recommended for chemical or petroleum plants, storage facilities, airports, warehouses, construction sites, equipment depots, and other high-hazard locations where dry chemical is the preferred agent. With 16" semi-pneumatic wheels, these units are highly mobile, permitting a single operator to extinguish fires that would normally require several operators with large portables. Equipped with brass valves.

P/N	SHIP. WEIGHT	UNIT HEIGHT	UNIT WIDTH	UNIT DEPTH
DDP19900B	435 lb	52"	27"	39"
DDP19906B	440 lb	52"	27"	39"
DDP19915B	415 lb	52"	27"	45"

P/N	DESCRIPTION	UL RATING
DDP19900B	145 lb ABC	40A:240B:C
DDP19906B	150 lb BC	240B:C
DDP19915B	125 lb PK	240B:C



Badger™ WHEELED CARBON DIOXIDE (CO₂) EXTINGUISHERS provide excellent protection for certain flammable liquids and energized electrical equipment. They can be operated by a single person, and the squeeze-grip control valve design allows for easy use. They are generally reserved for indoor use where wind and drafts will not disperse a discharge pattern. Carbon dioxide is a clean agent that leaves no residue. Equipped with brass valves.

P/N	SHIP. WEIGHT	UNIT HEIGHT	UNIT WIDTH	UNIT DEPTH
DDP22724B	271 lb	52"	21 ¹ / ₂ "	33"
DDP22725B	446 lb	52"	32"	33"

P/N	DESCRIPTION	UL RATING
DDP22724B	50 lb CO ₂	20B:C
DDP22725B	100 lb CO ₂	20B:C



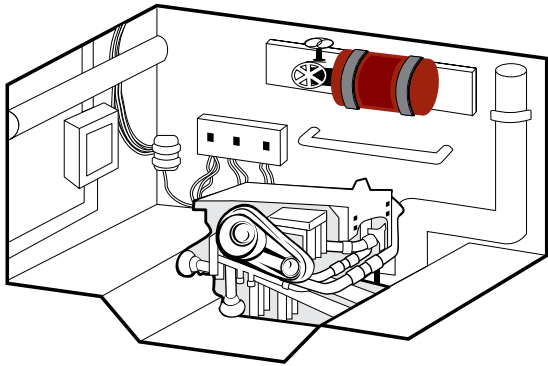

MOUNTED INSTALLATION

FIREBOY® FIRE EXTINGUISHERS

Fireboy® HFC-227 CLEAN AGENT FIRE

EXTINGUISHER SYSTEMS are the cleaner, safer, and more-effective alternative to dry chemical portable fire extinguishers.

They leave no residue or powdery mess behind and have a quicker fire-out time. When 175°F (79°C) is reached, the extinguisher will automatically discharge, releasing the clean agent gas to totally flood the entire space, smothering the fire. For occupied and unoccupied areas and most all marine applications. Approved for Class B fires.

P/N	DESCRIPTION	MAXIMUM VOLUME PROTECTED	SHELL DIAMETER	UNIT HEIGHT	SHIP WEIGHT
DDP25HFC227	HFC-227	25 cu ft	3.3"	9.5"	5 lb
DDP50HFC227	HFC-227	50 cu ft	3.3"	13.3"	8 lb
DDP75HFC227	HFC-227	75 cu ft	4.3"	15.6"	13 lb
DDP100HFC227	HFC-227	100 cu ft	4.3"	15.6"	14 lb
DDP125HFC227	HFC-227	125 cu ft	4.3"	15.6"	15 lb
DDP150HFC227	HFC-227	150 cu ft	5.1"	17.2"	20 lb
DDP175HFC227	HFC-227	175 cu ft	5.1"	17.2"	21 lb
DDP200HFC227	HFC-227	200 cu ft	5.1"	17.2"	22 lb
DDP225HFC227	HFC-227	225 cu ft	6.3"	17.3"	29 lb
DDP250HFC227	HFC-227	250 cu ft	6.3"	17.3"	30 lb
DDP275HFC227	HFC-227	275 cu ft	6.3"	17.3"	31 lb
DDP300HFC227	HFC-227	300 cu ft	6.3"	17.3"	32 lb
DDP325HFC227	HFC-227	325 cu ft	7.1"	17.2"	37 lb
DDP350HFC227	HFC-227	350 cu ft	7.1"	17.2"	38 lb
DDP375HFC227	HFC-227	375 cu ft	7.1"	17.2"	39 lb
DDP400HFC227	HFC-227	400 cu ft	7.1"	19.4"	43 lb
DDP450HFC227	HFC-227	450 cu ft	7.1"	19.4"	45 lb
DDP500HFC227	HFC-227	500 cu ft	7.1"	27.4"	55 lb
DDP550HFC227	HFC-227	550 cu ft	7.1"	27.4"	57 lb
DDP600HFC227	HFC-227	600 cu ft	7.1"	27.4"	60 lb
DDP650HFC227	HFC-227	650 cu ft	7.1"	27.4"	62 lb
DDP700HFC227	HFC-227	700 cu ft	7.1"	27.4"	64 lb
DDP750HFC227	HFC-227	750 cu ft	7.1"	33.3"	70 lb
DDP800HFC227	HFC-227	800 cu ft	7.1"	33.3"	73 lb
DDP850HFC227	HFC-227	850 cu ft	7.1"	33.3"	76 lb
DDP900HFC227	HFC-227	900 cu ft	7.1"	33.3"	77 lb
DDP950HFC227	HFC-227	950 cu ft	7.1"	33.3"	80 lb
DDP1000HFC227	HFC-227	1000 cu ft	10.0"	21.4"	93 lb
DDP1050HFC227	HFC-227	1050 cu ft	10.0"	21.4"	96 lb
DDP1100HFC227	HFC-227	1100 cu ft	10.0"	21.4"	99 lb
DDP1150HFC227	HFC-227	1150 cu ft	10.0"	27.5"	108 lb
DDP1200HFC227	HFC-227	1200 cu ft	10.0"	27.5"	111 lb
DDP1250HFC227	HFC-227	1250 cu ft	10.0"	27.5"	113 lb
DDP1300HFC227	HFC-227	1300 cu ft	10.0"	27.5"	116 lb
DDP1350HFC227	HFC-227	1350 cu ft	10.0"	27.5"	119 lb
DDP1400HFC227	HFC-227	1400 cu ft	10.0"	27.5"	121 lb
DDP1450HFC227	HFC-227	1450 cu ft	10.0"	27.5"	124 lb
DDP1500HFC227	HFC-227	1500 cu ft	10.0"	27.5"	126 lb



DDP25HFC227



DDP500HFC227

Fireboy® PANEL WARNING LIGHT features an attractive 2" round escutcheon plate with an adhesive back for easy panel mounting. The green warning lamp provides constant monitoring of the system, complying with USCG requirements for system approval.

P/N	DESCRIPTION
FBLKIT	Fire System Status Indicator Light w/ Panel

Fireboy® FIRE EXTINGUISHING SYSTEMS CABLES are for those who prefer the extra measure of control or for inspected vessels required to by USCG regulations. The normal mounting position of the manual discharge cable is at right angles to the panel for a straight-out pull.

P/N	DESCRIPTION
E42096	Manual Discharge Cable, 6'
E42098	Manual Discharge Cable, 8'
E420910	Manual Discharge Cable, 10'
E420912	Manual Discharge Cable, 12'
E420914	Manual Discharge Cable, 14'
E420916	Manual Discharge Cable, 16'
E420918	Manual Discharge Cable, 18'
E420920	Manual Discharge Cable, 20'
E420922	Manual Discharge Cable, 22'
DDPE420924	Manual Discharge Cable, 24'
E420926	Manual Discharge Cable, 26'
E420928	Manual Discharge Cable, 28'
E420930	Manual Discharge Cable, 30'

If fire breaks out aboard a diesel-powered vessel, continued operation may remove the agent, creating the possibility of re-ignition. But not with **Fireboy® AUTOMATIC SHUTDOWN SYSTEMS**—they respond automatically when a **Fireboy** system discharges. Available in three different model series, they can shut down up to eight different engines. All **Shutdown Systems** are solid state for greater reliability and come with an integrated alarm horn, charged/discharged lights, and an override switch for restart or control of auto shutdown.

P/N	DESCRIPTION
ES300001	Diesel Engine Shutdown, 12V, 3-Circuit
DDPE5500001	Diesel Engine Shutdown, 12V, 5-Circuit
ES501501	Diesel Engine Shutdown w/ GM Engine Time Delay, 12V, 5-Circuit
DDPE800001	Diesel Engine Shutdown, 12V, 8-Circuit
DDPE8000012432	Diesel Engine Shutdown, 24/32V, 8-Circuit
DDPE801501	Diesel Engine Shutdown w/ GM Engine Time Delay, 12V, 8-Circuit



FBLKIT



E42096



AUTOMATIC SHUTDOWN SYSTEMS

1 FIRE EXTINGUISHERS & CHEMICAL



50ABCULC



50BCPAIL



AX555



A9336



K804904



AX5302



A430182



A423320



A79372



PC551188

RECHARGE CHEMICAL

Our **UL CLASSIFIED UNIVERSAL DRY CHEMICAL** is ideal for use in many manufacturers' fire extinguishers, per NFPA 10. This dry chemical agent consists of a carefully controlled range of particle sizes blended with a flow-promoting and anti-caking chemical for smooth delivery. Each particle is silicone coated for optimum moisture repellency and minimum friction during discharge.

P/N	DESCRIPTION
50ABCULC	UL ABC Dry Chemical, 50 lb

Our **UNIVERSAL RECHARGE DRY CHEMICAL/POWDER** agents consist of a carefully controlled range of particle sizes of sodium bicarbonate or potassium bicarbonate, blended with a flow-promoting and anti-caking chemical. The agents are formulated and manufactured for both long discharge range and smooth, uninterrupted flow. Each particle is silicone coated to provide moisture repellency and minimum friction during discharge.

P/N	DESCRIPTION
50BCPAIL	BC Dry Chemical, 50 lb
50PKPAIL	PK Dry Chemical, 50 lb
50DPAIL	Class D Dry Powder (Sodium Chloride), 50 lb

OEM DRY CHEMICAL available from select warehouses. Call your Account Manager representative for availability.

P/N	DESCRIPTION
AX555	Amerex "High Performance" ABC Dry Chemical, 45 lb
AX550	Amerex ABC Dry Chemical, 50 lb
AX512	Amerex BC Dry Chemical, 50 lb
A53080	Ansul Foray ABC Dry Chemical, 45 lb
A9336	Ansul Plus-Fifty C Dry Chemical, 50 lb
400014B	Badger Advantage ABC Dry Chemical, 50 lb
B18905	Badger ABC Dry Chemical, 50 lb
B18903	Badger BC Dry Chemical, 50 lb
24124B	Badger Class D Powder Recharge, 50 lb
18907B	Badger PK Dry Chemical, 50 lb
BK61000	Buckeye ABC Dry Chemical, 50 lb
BK61400	Buckeye BC Dry Chemical, 50 lb
K806411	Kidde ABC Dry Chemical, 50 lb
K804904	Kidde BC Dry Chemical, 50 lb

OEM LIQUID CHEMICAL CHARGES for a wide variety of portable fire extinguisher types and models.

P/N	DESCRIPTION
AX506B2	Amerex Antifreeze Charge, Pkg/2 For 2.5 gal Loaded Stream Extinguishers, Model 240
AX534	Amerex AR-AFFF Charge, 2 gal
AX5302	Amerex Recharge, Pkg/2 For AX260
AX660	Amerex Recharge, Pkg/2 For AX262
AX502AR	Amerex AR-AFFF Premix Charge, 23 oz For 6 L and 2.5 gal & Extg, Models 250, 252, 254, 250CG
A430182	Ansul PRX Liquid, 6 L For K-Guard (K01, K01-1)
A423320	Ansul PRX Liquid, 5 gal For K-Guard (K01, K01-1)
A79372	Ansulex Chemical Agent, 3 gal For K-Guard (K01-2)
792B	Badger Antifreeze Charge For WP-61
AC100	Badger Recharge, 6 L, Pkg/2 For WC100
AC250	Badger Recharge, 2.5 gal For WC250
BK600872	Buckeye Recharge, 6 L
PC551188	RL-300 Recharge, 3 gal

Ansul®, K-Guard®, Ansulex®, Foray®, Plus-Fifty®, and PRX® are registered marks of Tyco Fire Products LP.



BROOKS
EQUIPMENT



20

CABINETS, ACCESSORIES, & COVERS

FIRE EXTINGUISHER CABINETS AND STANDS

Brooks' MARK SERIES FIRE EXTINGUISHER

CABINETS better fit today's extinguisher sizes and feature injection-molded ABS plastic construction, making them dent, rust, and corrosion proof. They come with a brass lock, plastic cover, and screen-printed pictograms on the sides. There is no glass to break or breaker bar to lose, and since they are light and nest easily together, freight charges are a fraction of what metal cabinets can cost. Priced per cabinet.

NOTE: See sizing chart below for dimensions.

MARK I JR. CABINET (M1J Series). Maximum extinguisher height: 16³/₄".

P/N	DESCRIPTION	LOCATION
MJM	Red Tub/Red Cover	Indoor/Outdoor
MJM6	Red Tubs/Red Covers, Pkg/6	Indoor/Outdoor
MJRC	Red Tub/Clear Cover	Indoor
MJRC6	Red Tubs/Clear Covers, Pkg/6	Indoor
MJWR	White Tub/Red Cover	Indoor
MJWR6	White Tubs/Red Covers, Pkg/6	Indoor
MJWC	White Tub/Clear Cover	Indoor
MJWC6	White Tubs/Clear Covers, Pkg/6	Indoor

MARK II JR. CABINET (M2J Series). Maximum extinguisher height: 20".

P/N	DESCRIPTION	LOCATION
M2JM	Red Tub/Red Cover	Indoor/Outdoor
M2JM6	Red Tubs/Red Covers, Pkg/6	Indoor/Outdoor
M2JRC	Red Tub/Clear Cover	Indoor
M2JRC6	Red Tubs/Clear Covers, Pkg/6	Indoor
M2JWR	White Tub/Red Cover	Indoor
M2JWR6	White Tubs/Red Covers, Pkg/6	Indoor
M2JWC	White Tub/Clear Cover	Indoor
M2JWC6	White Tubs/Clear Covers, Pkg/6	Indoor

MARK II CABINET (M2 Series). Maximum extinguisher height: 24".

P/N	DESCRIPTION	LOCATION
M2M	Red Tub/Red Cover	Indoor/Outdoor
M2M6	Red Tubs/Red Covers, Pkg/6	Indoor/Outdoor
M2RC	Red Tub/Clear Cover	Indoor
M2RC6	Red Tubs/Clear Covers, Pkg/6	Indoor
M2WR	White Tub/Red Cover	Indoor
M2WR6	White Tubs/Red Covers, Pkg/6	Indoor
M2WC	White Tub/Clear Cover	Indoor
M2WC6	White Tubs/Clear Covers, Pkg/6	Indoor

NOTE: The MJM, M2JM, and M2M Series cabinets are the only ones recommended for outdoor use.

MARK SERIES CABINET and COVER dimensions (see Cabinet Sizing Diagram).

CABINET	A HEIGHT	B WIDTH	C DEPTH	MAX EXTG HEIGHT
M1J SERIES	18 ¹ / ₄ "	8 ¹ / ₂ "	5 ³ / ₈ "	16 ³ / ₄ "
M2J SERIES	21 ³ / ₄ "	9 ⁵ / ₈ "	6 ³ / ₈ "	20"
M2 SERIES	25 ³ / ₄ "	9 ⁵ / ₈ "	6 ³ / ₈ "	24"

COVER	A HEIGHT	B WIDTH
M1J SERIES	19 ¹ / ₄ "	8 ⁷ / ₈ "
M2J SERIES	23"	10 ³ / ₁₆ "
M2 SERIES	27"	10 ³ / ₁₆ "

NOTE: The "A Height" dimension is from the top of the cabinet to below where the padlock is attached, as shown in the diagram to the left.



MJM In Use

MJWC In Use



M2JRC In Use

M2JWR In Use

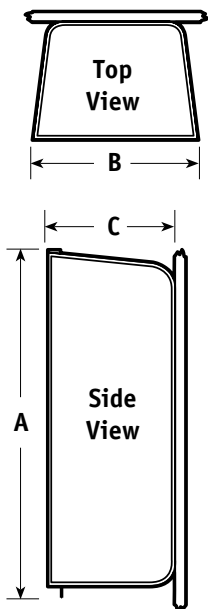

CABINET SIZING DIAGRAM

The All Everything Indoor/Outdoor Cabinet

FireTech™ FIRE EXTINGUISHER CABINETS work well indoors or out, thanks to their high-impact polystyrene construction and ultraviolet inhibitors that keep the color from fading, regardless of the weather or environment. They nest together, and their light weight reduces shipping costs over metal cabinets. Each cabinet includes an injection-molded frame, a scored break front, plastic cam lock with key, break-front striker, and a screen printed pictogram on the side. All **FireTech** parts are interchangeable with **CATO Chief Cabinets**.

P/N	DESCRIPTION
FT5PR	Red Cabinet
FT5PR6	Red Cabinets, Pkg/6
FT5PW	White Cabinet
FT5PW6	White Cabinets, Pkg/6
FT10PR	Red Cabinet
FT10PR6	Red Cabinets, Pkg/6
FT10PW	White Cabinet
FT10PW6	White Cabinets, Pkg/6
FT20PR	Red Cabinet
FT20PW	White Cabinet



FT10PW, FT5PR

FireTech™ FIRE EXTINGUISHER CABINET dimensions.

CABINET	HEIGHT	WIDTH	DEPTH	MAX EXTG HEIGHT
FT5_	19"	8"	6 ³ / ₈ "	16 ³ / ₄ "
FT10_	23"	9"	7"	20 ⁵ / ₈ "
FT20_	28"	11"	9"	25 ³ / ₄ "

REPLACEMENT COVERS for **Brooks'** extinguisher cabinets. See sizing chart on page 26 for dimensions. Pkg/6 (priced per cover). **NOTE:** Individual covers are available—call your Account Manager for pricing.

P/N	DESCRIPTION
MJCR6	M1J Series Red Covers
MJC6	M1J Series Clear Covers
M1CR6	M1 Series Red Covers
M1C6	M1 Series Clear Covers
M2JCR6	M2J Series Red Covers
M2JC6	M2J Series Clear Covers
M2CR6	M2 Series Red Covers
M2C6	M2 Series Clear Covers



REPLACEMENT COVERS

FireTech™ FIRE EXTINGUISHER CABINET ACCESSORIES.

P/N	DESCRIPTION
FT5RF	FT5 Red Frame & Lock
FT5WF	FT5 White Frame & Lock
FT10RF	FT10 Red Frame & Lock
FT10WF	FT10 White Frame & Lock
FT20RF	FT20 Red Frame & Lock
FT20WF	FT20 White Frame & Lock
FT55	FT5 Replacement Panel
FT510	FT10 Replacement Panel
FT520	FT20 Replacement Panel
FTRCL	Cylinder Lock, Red
FTWCL	Cylinder Lock, White
FT100R	Break-Front Striker Assy (Hammer Style), Red
FT100W	Break-Front Striker Assy (Hammer Style), White



FT10WF, FT5RF, FT55



FT100R



FES1 In Use

Make moving fire extinguishers from job site to job site easy with this **PORTABLE EXTINGUISHER STAND**. It holds a 5, 10, or 20 lb dry chemical extinguisher and has a molded-in handle for ease of movement, and a large 2½" fill hole for the addition of sand (up to 35 lb—sand not included). Constructed of red powder-coated steel, it is pre-drilled for a fire extinguisher wall hook.

P/N	DESCRIPTION	H X W X D
FES1	Portable Extinguisher Stand	48" x 16" x 16"



FT101 In Use

The **FireTech™ ABS EXTINGUISHER CABINET** protects extinguishers or life safety equipment from the harshest of environments. The clear door allows easy inspection, while the door-swing preference (left or right) and gasket provides long-term weather protection. A quick-release catch ensures rapid access to what is inside. Red tub, clear door.

P/N	DESCRIPTION	H X W X D
FT101	ABS Extinguisher Cabinet	30" x 11" x 8¼"



FGC35R, FGC26

A major step up in fire extinguisher storage and protection, **FireTech™ FIBERGLASS CABINETS** are designed to ward off salt air, chemicals, moisture, dust, insects, temperature extremes, and other harmful elements. These durably constructed cabinets feature a door-sealing method that shuts out most anything and an easy-view window and corrosion-resistant handle for extra convenience. All cabinets come standard with full-length stainless steel hinges, rivets, and latches for added peace of mind. Comes in UV-resistant high-visibility red.

P/N	HEIGHT	WIDTH	DEPTH	MAX EXTG HEIGHT
FGC10	26⅞"	13¼"	9¾"	23½"
FGC26	27⅞"	15¾"	10½"	24½"
FGC35R	36⅞"	19⅝"	14"	33"

P/N	DESCRIPTION
FGC10	Small Fiberglass Cabinet
FGC26	Medium Fiberglass Cabinet
FGC35R	Large Fiberglass Cabinet
FGCLATCH	Replacement Latch
FGCRG	Replacement Gasket

In Use photos may show items not included or available separately.

The **FireTech™ FIBERGLASS CABINET STAND** is designed for use with the **FGC26 Fiberglass Cabinet** (not included). Its red finish perfectly matches this cabinet, and it comes with four pre-drilled holes for permanent attachment to docks or other locations, or sand can be added for temporary placement. Mounting holes and hardware for attaching the cabinet to the stand are standard. 8¹/₄" x 11³/₄" top surface. Red.

P/N	DESCRIPTION	H X W X D
FES2	Fiberglass Cabinet Stand For FGC26 Cabinet	27 ¹ / ₂ " x 15 ¹ / ₂ " x 15 ¹ / ₂ "



FES2 In Use

PORTABLE EXTINGUISHER CABINETS & STANDS

solve the problem of locating fire extinguishers on jobsites, project areas, and in remote locations. Constructed from rust/fade-proof materials that meet Cal and OSHA requirements, these cabinet/stand combos come with handles for convenient carry. Other standard features include scored break fronts, cylinder locks, heavy-duty rubber stand bases, informational decals, and stackable storage/transport. Units measure 43"H x 20"W x 20"D. White/Red.

P/N	DESCRIPTION
FGSWC10	Portable Cabinet & Stand, 10 lb
FGSWC20	Portable Cabinet & Stand, 20 lb



FGSWC10 In Use

The **Original Firemate** is a stackable **PORTABLE FIRE EXTINGUISHER STAND** that is made of tough HDPE plastic. The stand holds 5, 10, or 20 lb extinguishers, and its wide base resists tipping. Meets OSHA requirements. 8"H x 7¹/₄"W x 7¹/₄"D recess for extinguisher. Red.

P/N	DESCRIPTION	H X W X D
FMRGC	Portable Extinguisher Stand	34" x 21" x 21"



FMRGC In Use

2 CABINETS, ACCESSORIES, & COVERS



FT916 In Use



BEA003, BEA004, BEA005

Made of 20 ga galvanized steel, **FireTech™** surface-mount **METAL FIRE EXTINGUISHER CABINETS** are rust resistant and come with white powder-coat finishes, keyed-alike cylinder locks, and scored polystyrene break fronts. Break-front strikers sold separately. Ideal for interior or exterior use.

P/N	DESCRIPTION	H X W X D
FT916	Metal Cabinet	19 ¹³ / ₁₆ " x 8 ¹ / ₂ " x 6 ¹ / ₄ "
FT926	Metal Cabinet	25 ³ / ₄ " x 9 ¹ / ₂ " x 6 ¹ / ₄ "
FT936	Metal Cabinet	29 ³ / ₄ " x 10 ¹ / ₂ " x 8 ¹ / ₄ "
BEA003	Replacement Top Panel w/ Lock For FT916	
BEA004	Replacement Top Panel w/ Lock For FT926	
BEA005	Replacement Top Panel w/ Lock For FT936	



BE916 In Use



BEA003, BEA004, BEA005

Surface-mount **Classic Series METAL FIRE EXTINGUISHER CABINETS** are made of 20 ga galvanized steel with a bright-white finish, keyed-alike cylinder lock, and breakable polystyrene front. Break-front strikers sold separately.

P/N	DESCRIPTION	H X W X D
BE916	Cabinets, Pkg/2	19 ¹³ / ₁₆ " x 8 ¹ / ₂ " x 6 ¹ / ₄ "
BE926	Cabinets, Pkg/2	25 ³ / ₄ " x 9 ¹ / ₂ " x 6 ¹ / ₄ "
BE936	Cabinets, Pkg/2	29 ³ / ₄ " x 10 ¹ / ₂ " x 8 ¹ / ₄ "
BEA003	Replacement Top Panel w/ Lock For BE916	
BEA004	Replacement Top Panel w/ Lock For BE926	
BEA005	Replacement Top Panel w/ Lock For BE936	



924TW2

Decorline FIRE EXTINGUISHER CABINETS are constructed from cold-rolled steel with white baked-on finishes. They are equipped with 2" projecting trim to hide wall cutouts and sliding acrylic break fronts for easy access. Break-front strikers and lock sold separately. Pkg/2.

P/N	TRIM	TUB ID			FRAME OD		WALL OPENING		
		H	W	D	H	W	H	W	D
818TW2	2 ¹ / ₂ "	18"	8 ¹ / ₈ "	5 ¹ / ₂ "	21"	11 ¹ / ₈ "	19"	9"	4"
924TW2	2 ¹ / ₂ "	24"	9 ¹ / ₈ "	5 ¹ / ₂ "	27"	12 ¹ / ₈ "	25"	10"	4"

P/N	DESCRIPTION
818TW2	Cabinets
924TW2	Cabinets



818W2, 818G2, 924W2, 924G2, 1028W2BX, 1028G2BX

Economyline FIRE EXTINGUISHER CABINETS are constructed from cold-rolled steel with hammertone gray or white baked-on finishes. Cabinets come equipped with sliding acrylic break fronts. Break-front strikers and locks sold separately. Pkg/2.

P/N	DESCRIPTION	H X W X D (INTERIOR)
818G2	Gray Cabinets	18" x 8 ¹ / ₈ " x 5 ¹ / ₂ "
818W2	White Cabinets	18" x 8 ¹ / ₈ " x 5 ¹ / ₂ "
924G2	Gray Cabinets	24" x 9 ¹ / ₈ " x 5 ¹ / ₂ "
924W2	White Cabinets	24" x 9 ¹ / ₈ " x 5 ¹ / ₂ "
1028G2BX	Gray Cabinets	28" x 10 ¹ / ₈ " x 8 ¹ / ₄ "
1028W2BX	White Cabinets	28" x 10 ¹ / ₈ " x 8 ¹ / ₄ "

The **ACADEMY, AMBASSADOR, and COSMOPOLITAN SERIES CABINETS**, manufactured by **J.L. Industries**, are some of the finest cabinets available. They are made of aluminum with a clear anodized finish (**Academy**) or steel with electrostatic white epoxy primer finish (**Ambassador**) or all stainless steel (**Cosmopolitan**). All cabinets include a continuous hinge door and acrylic front with squared edge construction. (The 3" trim model has rolled edge construction).

Three different acrylic door styles are stocked: **Full Acrylic, Full Acrylic with Saf-T-Lok**, and **Contemporary V. Full Acrylic and Contemporary V** models are equipped with zinc-plated pull handles and roller catches, while the **Full Acrylic with Saf-T-Lok** models use pull handles with keyed-alike cylinder locks and flexible cams.

NOTE: Remember to add the wall material thickness to your wall depth when determining the cabinet you need. Not responsible for acrylic breakage during shipping.

MODELS	TRIM	TUB ID			FRAME OD		WALL OPENING			
		A	B	C	E	F	H	W	D	
1013	Surf	27 ³ / ₁₆ "	13 ¹¹ / ₁₆ "	6 ¹ / ₂ "	27 ³ / ₈ "	13 ⁷ / ₈ "	-	-	-	-
1015	Flat	24"	10 ¹ / ₂ "	6"	27 ³ / ₈ "	13 ⁷ / ₈ "	25"	11 ¹ / ₂ "	5 ⁷ / ₈ "	
1017	3"	24"	10 ¹ / ₂ "	6"	27 ³ / ₈ "	13 ⁷ / ₈ "	25"	11 ¹ / ₂ "	3 ¹ / ₈ "	
1017FX	3"	24"	10 ¹ / ₂ "	6"	27 ³ / ₈ "	13 ⁷ / ₈ "	26 ⁵ / ₁₆ "	12 ¹³ / ₁₆ "	4"	
1413	Surf	17 ³ / ₁₆ "	17 ³ / ₁₆ "	7"	17 ³ / ₈ "	17 ³ / ₈ "	-	-	-	
1417	3"	14"	14"	6 ³ / ₄ "	17 ³ / ₈ "	17 ³ / ₈ "	15 ¹ / ₄ "	15 ¹ / ₄ "	3 ³ / ₄ "	
1815	Flat	24"	10 ¹ / ₂ "	5 ¹ / ₂ "	27 ³ / ₈ "	13 ⁷ / ₈ "	25"	11 ¹ / ₂ "	5 ³ / ₈ "	
1816	1 ¹ / ₂ "	24"	10 ¹ / ₂ "	5 ¹ / ₂ "	27 ³ / ₈ "	13 ⁷ / ₈ "	25"	11 ¹ / ₂ "	4 ¹ / ₈ "	
1817	3"	24"	10 ¹ / ₂ "	5 ¹ / ₂ "	27 ³ / ₈ "	13 ⁷ / ₈ "	25"	11 ¹ / ₂ "	2 ⁵ / ₈ "	
2015	Flat	27"	12"	7 ³ / ₄ "	30 ³ / ₈ "	15 ³ / ₈ "	28"	13"	7 ⁵ / ₈ "	
1027	3"	24"	10 ¹ / ₂ "	6"	27 ³ / ₈ "	13 ⁷ / ₈ "	25"	11 ¹ / ₂ "	3 ¹ / ₈ "	
1037	3"	24"	10 ¹ / ₂ "	6"	27 ³ / ₈ "	13 ⁷ / ₈ "	25"	11 ¹ / ₂ "	3 ¹ / ₈ "	
1037FX	3"	24"	10 ¹ / ₂ "	6"	27 ³ / ₈ "	13 ⁷ / ₈ "	26 ⁵ / ₁₆ "	12 ¹³ / ₁₆ "	4"	

AMBASSADOR SERIES CABINETS

P/N	DESCRIPTION
1013F10	Cabinet, Acrylic, Surface Mount
1015F10	Cabinet, Acrylic, Flat Trim
1017F10	Cabinet, Acrylic, 3" Trim
1017F10FX	Cabinet, Acrylic, 3" Trim (Fire Rated)
1815F10	Cabinet, Acrylic, Flat Trim
1816F10	Cabinet, Acrylic, 1 ¹ / ₂ " Trim
1817F10	Cabinet, Acrylic, 3" Trim
2015F10	Cabinet, Acrylic, Flat Trim
1017S21	Cabinet, Solid, 3" Trim
P/N	DESCRIPTION
1013G10	Cabinet, Saf-T-Lok, Surface Mount
1015G10	Cabinet, Saf-T-Lok, Flat Trim
1017G10	Cabinet, Saf-T-Lok, 3" Trim
1815G10	Cabinet, Saf-T-Lok, Flat Trim
1816G10	Cabinet, Saf-T-Lok, 1 ¹ / ₂ " Trim
1817G10	Cabinet, Saf-T-Lok, 3" Trim
2015G10	Cabinet, Saf-T-Lok, Flat Trim
JLLC	Saf-T-Lok Cam

P/N	DESCRIPTION	H X W
JLRA	Replacement Acrylic For 10 & 18 Series Cabinets	22 ³ / ₄ " x 8 ¹ / ₂ "

The **AMBASSADOR SERIES CABINETS** with **Contemporary** vertical duo panel door.

P/N	DESCRIPTION
1013V10	Cabinet, Duo, Surface Mount
1015V10	Cabinet, Duo, Flat Trim
1017V10	Cabinet, Duo, 3" Trim
1815V10	Cabinet, Duo, Flat Trim
1816V10	Cabinet, Duo, 1 ¹ / ₂ " Trim
1817V10	Cabinet, Duo, 3" Trim
2015V10	Cabinet, Duo, Flat Trim

ACADEMY and COSMOPOLITAN™ SERIES CABINETS with **Full Acrylic** door.

P/N	DESCRIPTION
1027F10	Cabinet, 3" Trim, Aluminum
1037F10	Cabinet, 3" Trim, Stainless Steel

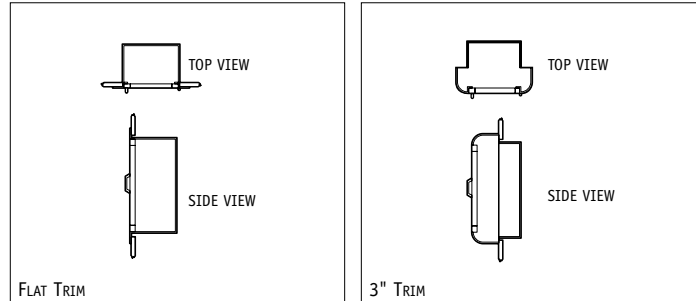
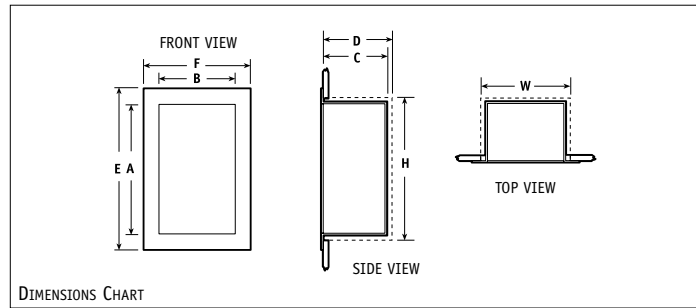

In Use photos may show items not included or available separately.

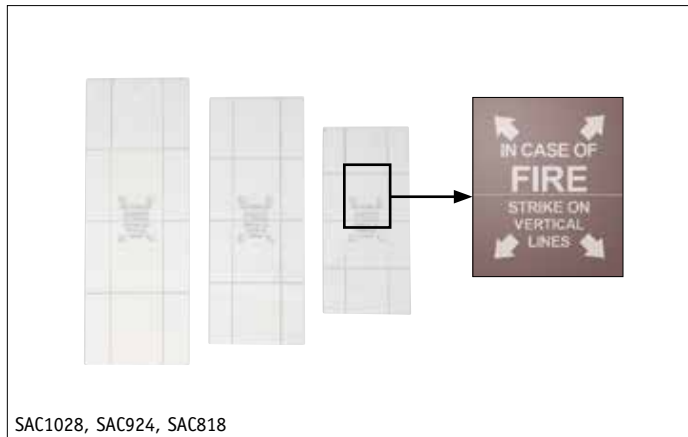

SAC1028, SAC924, SAC818



818CW



BR13



BGH6

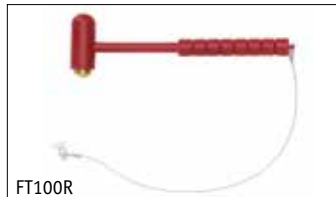

FT100R



CFAW In Use



STI6200 In Use

CABINET ACCESSORIES

FireTech™, Economyline, Decorline, and Classic Series fire extinguisher cabinet **ACCESSORIES** include replacement cabinet covers, glass clips, and break front tools. The clear replacement covers are grid scored for faster and easier access to fire extinguishers. Injection-molded polystyrene covers are screen printed so respondents know exactly where to strike in case of fire. (See-through scored covers are much easier to break than un-scored versions.)

P/N	DESCRIPTION
SAC818	Scored Polystyrene Break Front, Clear For BE916, FT916, & 818 Series Cabinets, 17 ⁷ / ₈ " x 8"
SAC924	Scored Polystyrene Break Front, Clear For BE926, FT926, & 924 Series Cabinets, 23 ⁷ / ₈ " x 9"
SAC1028	Scored Polystyrene Break Front, Clear For BE936, FT936, & 1028 Series Cabinets, 27 ⁷ / ₈ " x 10"
818C	8" Glass Clip, Gray Fits Economyline & Decorline Cabinets
818CW	8" Glass Clip, White Fits Economyline & Decorline Cabinets
924C	9" Glass Clip, Gray Fits Economyline & Decorline Cabinets
924CW	9" Glass Clip, White Fits Economyline & Decorline Cabinets
1028C	10" Glass Clip, Gray Fits Economyline & Decorline Cabinets
1028CW	10" Glass Clip, White Fits Economyline & Decorline Cabinets
BR13	Break-Front Striker Assy (Bar Style)
BGH6	Break-Front Striker Assy (Hammer Style)
FT100R	Break-Front Striker Assy (Hammer Style), Red
FT100W	Break-Front Striker Assy (Hammer Style), White

A **Brooks** exclusive, these fire extinguisher **CABINET ALARMS** sound off with a 105 dB (measured at 1') alarm when the extinguisher is removed. They are self-adhesive and install in seconds. Measures 2³/₄"H x 2¹/₄"W x 1"D. Batteries not included.

P/N	DESCRIPTION
CFAW	White Cabinet Alarm
CFAR	Red Cabinet Alarm
TF9VB	9V Alkaline Battery

STI's FIRE EXTINGUISHER THEFT STOPPER helps stop theft, vandalism, and misuse of fire extinguishers. If the protected fire extinguisher is moved or jostled, **Theft Stopper** emits an instantaneous, piercing alarm. A highly visible "STOP, EMERGENCY USE ONLY" further deters unauthorized handling. The **Theft Stopper** is simple to install and comes with a deactivation cable (for when extinguisher needs servicing). Red.

P/N	DESCRIPTION
STI6200	Theft Stopper

These **FIRE EXTINGUISHER DECALS** are for labeling cabinets and bubble covers, as required by various AHJs. Choice of horizontal or vertical decals with red lettering on clear background.

P/N	DESCRIPTION	H X W
BL253	"Fire Extinguisher" Decal For Cabinet	19" x 2"
BL254	"Fire Extinguisher" Decal For Cabinet	2 1/4" x 7 1/8"
BL255	"Fire Extinguisher" Decal For Small Bubble	13" x 3/8"
BL256	"Fire Extinguisher" Decal For Large Bubble	16 1/2" x 1 1/2"

Brooks' BUBBLE COVERS are designed for use on metal extinguisher cabinets with full door styles. Both models offer transparency for good extinguisher visibility. Polycarbonate models offer extra strength for added security. Decals sold separately.

P/N	DESCRIPTION	H X W X D
ABUB1	X-Small Acrylic Cover (Larsens)	21 1/2" x 6 3/4" x 4"
ABUB2	Small Acrylic Cover (JL)	22 1/4" x 8 1/2" x 4"
ABUB3	Large Acrylic Cover (JL)	28" x 11 13/16" x 5"
ABUB4	Large Acrylic Cover (Larsens Steel)	28 1/2" x 12 5/8" x 4"
ABUB5	Large Acrylic Cover (Larsens Alum)	29 1/2" x 13 1/4" x 4"
PBUB1	X-Small Poly Cover (Larsens)	21 1/2" x 6 3/4" x 4"
PBUB2	Small Poly Cover (JL)	22 1/4" x 8 1/2" x 4"
PBUB3	Large Poly Cover (JL)	28" x 11 13/16" x 5"
PBUB4	Large Poly Cover (Larsens)	28 1/2" x 12 5/8" x 4"
PBUB5	Large Poly Cover (Larsens)	29 1/2" x 13 1/4" x 4"

The **Brooks BREAKAWAY BRASS PADLOCK** safely secures cabinets and other equipment. Designed to be opened with a key (included) or broken away in an emergency. 7/8" inside shackle.

P/N	DESCRIPTION
SBL66	Breakaway Brass Padlock

Master Lock is a name synonymous with quality padlocks. The keyed-alike **BREAKAWAY STEEL PADLOCK** has a 1 3/4"-wide laminated steel body for superior strength and comes with two keys and a steel shackle for superior cut resistance. A warded locking mechanism helps minimize jamming caused by dirt and grime. Rustproof. 13/16" inside shackle.
NOTE: Locks are keyed alike to #197.

P/N	DESCRIPTION
ML500KA	Breakaway Steel Padlock

Corrosion-resistant **Brooks BRASS PADLOCK** features an all-brass shackle, making it ideal for cabinets and other security requirements where economy and keyed-alike convenience is essential. 3/8" inside shackle.

P/N	DESCRIPTION
M12L	Brass Padlock

NYLON & STEEL SHACKLED PADLOCKS feature non-conductive polymer bodies and reinforced nylon or steel shackles. Write-on labels and one key are standard too. Locks are keyed differently. 3/4" inside shackle.

P/N	DESCRIPTION
→ BN15L	Padlock w/ Nylon Shackle, Red
→ TPR15L	Padlock w/ Steel Shackle, Red
→ TPY15L	Padlock w/ Steel Shackle, Yellow
→ TPG15L	Padlock w/ Steel Shackle, Green
→ TPB15L	Padlock w/ Steel Shackle, Blue



BL254



BL255 In Use



BL253



ABUB2 In Use



SBL66



ML500KA



M12L



→ NEW
BN15L



PPL



MS5100 In Use



MS5100

This single-use **PLASTIC PADLOCK** must be cut or broken away. ³/₄" inside shackle. Red.

P/N	DESCRIPTION
PPL	Plastic Padlock

ADHESIVE-BACKED MAGNETIC STRIP makes mounting signs, breaker bars, and other metal goods a snap. **MS5100** is designed to withstand temperatures from -40°F to 160°F. Each **Magnetic Strip** comes with a peel-off liner and durable outdoor adhesive for good adherence. 1/2" x 100' roll.

P/N	DESCRIPTION
MS5100	Magnetic Strip

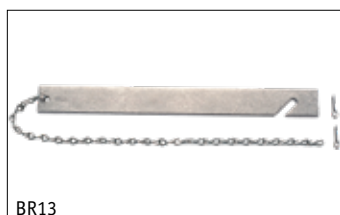

BR13



BGH6

BREAK FRONT STRIKERS are designed to easily break glass or plastic break-front-type cabinet covers.

P/N	DESCRIPTION
BR13	Break-Front Striker Assy (Bar Style)
BGH6	Break-Front Striker Assy (Hammer Style)
FT100R	Break-Front Striker Assy (Hammer Style), Red
FT100W	Break-Front Striker Assy (Hammer Style), White



FT100R



PTD182



PTD108

3-D RIGID PLASTIC ANGLE SIGNS

P/N	DESCRIPTION	L X H
PTD108	"Fire Extinguisher" 3D Arrow Sign	4" x 12"
PTD109	"Fire Extinguisher" 3D Arrow Sign	4" x 18"
PTD182	"Fire Extinguisher" 3D Arrow Sign	5" x 6"
PTD109B	"Fire Extinguisher" 3D Arrow Sign, Bilingual	9 1/4" x 18"

For More Signs, See Section 9.

Brooks exclusive auxiliary **CABINET KEY SET** will open **Brooks, FireTech™, Cato, J.L. Industries, Larsen's, Modern Metal, Potter Roemer, Rome Metal, Samson, Heiser, and Thomas Enterprises** fire extinguisher cabinets. Set includes a durable cross reference tag for easy identification.

P/N	DESCRIPTION
CKS	Cabinet Key Set



CKS

The **UNIVERSAL CAM LOCK** assembly is for changing out damaged or worn-out locks and is adaptable to most cabinets. Comes with two cam choices and keys.

P/N	DESCRIPTION
UCL	Replacement Cam Lock



UCL



JLHP

JL Cabinets REPLACEMENT HARDWARE works perfectly with **JL Cabinets**. The **Cam Lock Assembly** replaces old, worn-out cam locks on **JL Cabinets**. **Hardware Pack** includes a friction roller catch and glass clips.

P/N	DESCRIPTION
JLHP	Hardware Pack For JL Cabinets
JLSL	Safety Cam Lock Assy For JL Cabinets
JLLC	Saf-T-Lok Cam For JL Cabinets



JLSL



JLLC

KEY BOX

Keep track of keys with this **KEY BOX** from **Brooks**. It is made of durable ABS plastic in a two-piece design that allows for easier access in an emergency. The polystyrene cover snaps right into place. Measures 4 1/4" x 1 1/4". Red.

P/N	DESCRIPTION
BKB	ABS Key Box "Break Glass For Key"
KBRC	Replacement Plastic Cover For BKB



BKB In Use

LOCK BOX

16 ga steel **FIRE DEPARTMENT LOCK BOX** adds up to a lot of security. Measures 6"H x 4"W x 1 1/2"D. Red.

P/N	DESCRIPTION
LBFD	FD Lock Box



LBFD



FEC8



FEC1



FEC1W In Use



FEC4E



FEC4EW In Use



WUC3



FHDC1

FIRE EXTINGUISHER COVERS

HEAVY-DUTY FIRE EXTINGUISHER COVERS are made of acrylic-coated polyester with hook-and-loop closures for the harshest conditions. Based on test results, covers have a minimum five-year lifespan—outdoors, under normal conditions. Covers fit portable, pressurized, and cartridge-operated extinguishers. Red.

P/N	DESCRIPTION	H X W
FEC10	X-Small Heavy-Duty Cover	18½" x 7"
FEC7	Small Heavy-Duty Cover	20" x 11½"
FEC8	Medium Heavy-Duty Cover	25" x 16½"
FEC9	Large Heavy-Duty Cover	31" x 16½"

Brooks FIRE EXTINGUISHER COVERS are made of reinforced vinyl with hook-and-loop closures or elastic-back and pull bottom tabs/straps for easy, long-lasting use. Red.

P/N	DESCRIPTION	H X W
FEC1	Small Cover w/ Hook-and-Loop Closure	20" x 11½"
FEC1W	Small Cover w/ Hook-and-Loop Closure, Window	20" x 11½"
FEC2	Medium Cover w/ Hook-and-Loop Closure	25" x 16½"
FEC2W	Medium Cover w/ Hook-and-Loop Closure, Window	25" x 16½"
FEC3	Large Cover w/ Hook-and-Loop Closure	31" x 16½"
FEC3W	Large Cover w/ Hook-and-Loop Closure, Window	31" x 16½"

P/N	DESCRIPTION	H X W
FEC4E	X-Small Cover w/ Elastic-Back, Pull Bottom Tab	18½" x 6"
FEC4EW	X-Small Cover w/ Elastic-Back, Pull Bottom Tab, Window	18½" x 6"
FEC5E	Small Cover w/ Elastic-Back, Pull Bottom Strap	22½" x 6¼"
FEC5EW	Small Cover w/ Elastic-Back, Pull Bottom Strap, Window	22½" x 6¼"
FEC6E	Medium Cover w/ Elastic-Back, Pull Bottom Strap	25½" x 8"
FEC6EW	Medium Cover w/ Elastic-Back, Pull Bottom Strap, Window	25½" x 8"

WHEELED UNIT COVERS feature the same qualities as the **Fire Extinguisher Covers**, in standard or heavy-duty material. Red.

P/N	DESCRIPTION	H X W X D
WUC50	50 lb DC Cover	47½" x 16" x 24"
WUC3	50 & 75 lb CO ₂ Cover	54" x 16" x 27"
WUC6	50 & 75 lb CO ₂ Heavy-Duty Cover	54" x 16" x 27"
WUC1	150 lb Cover	53" x 42" x 30"
WUC4	150 lb Heavy-Duty Cover	53" x 42" x 30"
WUC2	350 lb Cover	58" x 52" x 38"
WUC5	350 lb Heavy-Duty Cover	58" x 52" x 38"

HEAVY-DUTY FIRE HYDRANT COVER is made of reinforced vinyl with a hook-and-loop closure and comes with reinforced grommets that allow for chain/wire attachment to prevent removal. Fluorescent Red.

P/N	DESCRIPTION
FHDC1	Heavy-Duty Hydrant Cover



CO

FIRE HOSE, NOZZLES, BRASS, & HOSE VALVES

Pre-Folded For Pin Racks

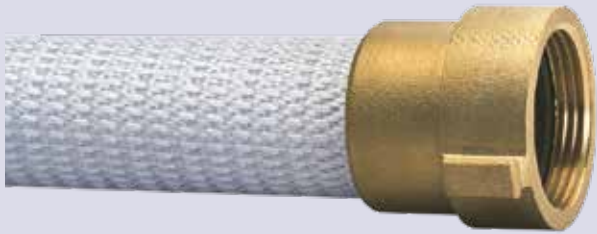

FT75NST

For emergency use only, **FireTech™ RACK & REEL FIRE HOSE** is fully lined, FM approved, and a great value. It has a proof test pressure of 500 psi, service test of 250 psi, and comes folded for easy installation on pin racks. Brass couplings only. Imported.

NOTE: Not intended for purposes of washdown!

P/N	DESCRIPTION	BOWL SIZE	WEIGHT COUPLED
FT50NST or NPSH	50' x 1 1/2" RR Hose	1 11/16"	7 lb
FT75NST or NPSH	75' x 1 1/2" RR Hose	1 11/16"	9 lb
FT100NST or NPSH	100' x 1 1/2" RR Hose	1 11/16"	12 lb



FTSJ50NST

FIRE HOSE

A step up from standard **Rack & Reel Fire Hose**, and a great value, **FireTech's SINGLE JACKET FIRE HOSE** has a proof test pressure of 500 psi and a service test of 250 psi. It is FM approved and made of 100% polyester rubber-lined material for extra strength and flexibility. Brass NST coupled. Imported.

NOTE: Recommended for industrial fire protection.

P/N	DESCRIPTION	BOWL SIZE	WEIGHT COUPLED
FTSJ50NST	50' x 1 1/2" SJ Hose	1 13/16"	15 lb
FTSJ75NST	75' x 1 1/2" SJ Hose	1 13/16"	20 lb
FTSJ100NST	100' x 1 1/2" SJ Hose	1 13/16"	27 lb
FTSJ2550NST	50' x 2 1/2" SJ Hose	2 13/16"	27 lb

For emergency use only, this **RACK & REEL FIRE HOSE** is fully lined and FM approved. It has a proof test pressure of 500 psi, service test of 250 psi, and comes folded for easy installation on pin racks. Brass NST coupled.

NOTE: Not intended for purposes of washdown!

P/N	DESCRIPTION	BOWL SIZE	WEIGHT COUPLED
50NST	50' x 1 1/2" RR Hose	1 11/16"	7 lb
75NST	75' x 1 1/2" RR Hose	1 11/16"	9 lb
100NST	100' x 1 1/2" RR Hose	1 11/16"	12 lb

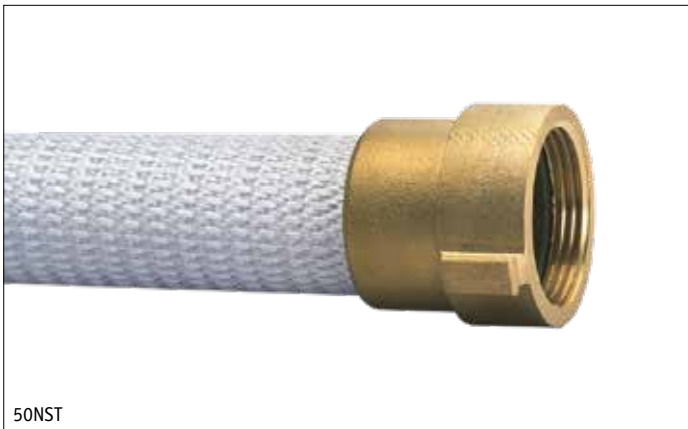

50NST

This **SINGLE JACKET FIRE HOSE** has a proof test pressure of 500 psi and a service test of 250 psi. It features 100% polyester rubber-lined material for extra strength and flexibility. FM approved.

NOTE: Recommended for industrial fire protection.

P/N	DESCRIPTION	BOWL SIZE	WEIGHT COUPLED
SJ50NST or NPSH	50' x 1 1/2" SJ Hose, Brass	1 13/16"	15 lb
SJ50ANST	50' x 1 1/2" SJ Hose, Alum	1 13/16"	13 lb
SJ75NST or NPSH	75' x 1 1/2" SJ Hose, Brass	1 13/16"	20 lb
SJ75ANST	75' x 1 1/2" SJ Hose, Alum	1 13/16"	18 lb
SJ100NST or NPSH	100' x 1 1/2" SJ Hose, Brass	1 13/16"	27 lb
SJ100ANST	100' x 1 1/2" SJ Hose, Alum	1 13/16"	25 lb
SJ2550NST or NPSH	50' x 2 1/2" SJ Hose, Brass	2 13/16"	27 lb
SJ2550ANST	50' x 2 1/2" SJ Hose, Alum	2 13/16"	25 lb
SJ25100NST	100' x 2 1/2" SJ Hose, Brass	2 13/16"	51 lb



SJ50NST

Pre-tested under UL supervision, this **UL LABELED SINGLE JACKET FIRE HOSE** features fully rubber lined 100% polyester construction. Every length carries the **UL®** mark and has a proof test pressure of 500 psi and a service test of 250 psi. Brass NST coupled.

NOTE: Recommended for industrial fire protection.

P/N	DESCRIPTION	BOWL SIZE	WEIGHT COUPLED
SJ50ULNST	50' x 1 1/2" UL Hose	1 13/16"	15 lb
SJ75ULNST	75' x 1 1/2" UL Hose	1 13/16"	20 lb
SJ100ULNST	100' x 1 1/2" UL Hose	1 13/16"	27 lb
SJ2550ULNST	50' x 2 1/2" UL Hose	2 13/16"	27 lb

DOUBLE JACKET FIRE HOSE features two jackets of 100% polyester rubber-lined material for added protection against cuts, rips, and abrasion. It has a proof test pressure of 800 psi and a service test of 400 psi. Meets NFPA 1961.

NOTE: Recommended for industrial fire protection.

P/N	DESCRIPTION	BOWL SIZE	WEIGHT COUPLED
DJ50NST or NPSH	50' x 1 1/2" DJ Hose, Brass	1 15/16"	20 lb
DJ50ANST	50' x 1 1/2" DJ Hose, Alum	1 15/16"	18 lb
DJ100NST	100' x 1 1/2" DJ Hose, Brass	1 15/16"	35 lb
DJ100ANST	100' x 1 1/2" DJ Hose, Alum	1 15/16"	32 lb
DJ2550NST	50' x 2 1/2" DJ Hose, Brass	3"	37 lb
DJ2550ANST	50' x 2 1/2" DJ Hose, Alum	3"	34 lb

This **YELLOW COATED FIRE HOSE** is constructed to the same specifications as the standard **Double Jacket Hose**. Every section of **Coated Hose** is independently and completely impregnated with an abrasion-resistant, water-repellent polymer for outstanding performance under tough conditions. Aluminum NST coupled.

NOTE: Recommended for industrial fire protection.

P/N	DESCRIPTION	BOWL SIZE	WEIGHT COUPLED
DJ50YHANST	50' x 1 1/2" YC Hose	1 15/16"	21 lb
DJ17550YHANST	50' x 1 3/4" YC Hose	2 1/8"	25 lb
DJ2550YHANST	50' x 2 1/2" YC Hose	3"	39 lb

RUBBER COVERED FIRE HOSE is the choice of professionals nationwide. Abrasion-resistant, it features a heat-free nitrile synthetic one-piece cover and liner that is impervious to water, oil, gas, and most chemicals. Lightweight, it is virtually kink-resistant for easy handling, and it never needs drying. It has a proof test pressure of 500 psi and a service test of 250 psi. Aluminum NST coupled. Meets NFPA 1961. Imported.

P/N	DESCRIPTION	BOWL SIZE	WEIGHT COUPLED
RCH50ANST	50' x 1 1/2" RC Hose	1 3/4"	11.5 lb
RCH100ANST	100' x 1 1/2" RC Hose	1 3/4"	22 lb
RCH2550ANST	50' x 2 1/2" RC Hose	2 1/2"	24 lb

→ **More FIRE HOSE Available - Call for Pricing.**



SJ50ULNST



DJ50NST



DJ50YHANST



RCH50ANST

3 FIRE HOSE, NOZZLES, BRASS, & HOSE VALVES

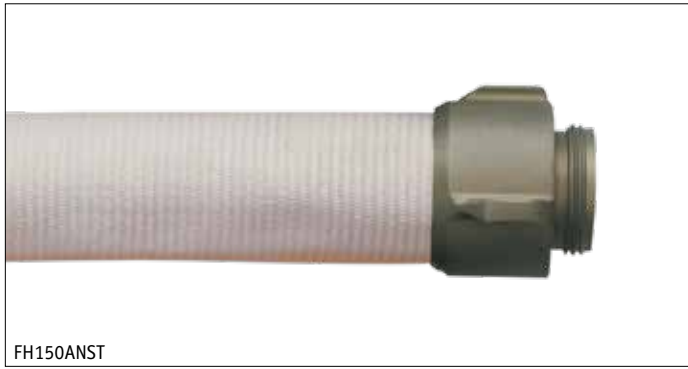

FH150ANST

This lightweight **FORESTRY HOSE** meets the USDA-US Forest Service Standard. Proof test pressure is 500 psi and service test is 250 psi. Aluminum NST coupled.

P/N	DESCRIPTION	BOWL SIZE	WEIGHT COUPLED
FH150ANST	50' x 1" Forestry Hose	1 ¹ / ₄ "	7 lb
FH1100ANST	100' x 1" Forestry Hose	1 ¹ / ₄ "	11 lb

Designed for structural, vehicle, grass, and forestry firefighting, **Reel Lite BOOSTER HOSE** features single jacket construction from virgin spun polyester warp yarn that is woven in a twill weave. Polyurethane lined and **Wear Guard** treated for extra toughness, hose has a proof test pressure of 600 psi and a service test of 300 psi. Aluminum NST coupled. Meets NFPA 1961.



BH150ANST

P/N	DESCRIPTION	BOWL SIZE	WEIGHT COUPLED
BH150ANST	50' x 1" Booster Hose	1 ⁹ / ₁₆ "	31 lb
BH1100ANST	100' x 1" Booster Hose	1 ⁹ / ₁₆ "	60 lb

FIRE HOSE COUPLINGS, RINGS, AND GASKETS

RACK & REEL HOSE COUPLINGS are made of cast brass or aluminum and come with rings and gaskets.

P/N	DESCRIPTION	BOWL SIZE
RHCNST	1 ¹ / ₂ " NST RR Cplgs, Brass	1 ¹¹ / ₁₆ "
ARHCNST	1 ¹ / ₂ " NST RR Cplgs, Alum	1 ¹¹ / ₁₆ "
RHTG	RR Tail Gasket	1 ¹¹ / ₁₆ "
SJSG15	1 ¹ / ₂ " RR Swivel Hose Gasket	
ER15	1 ¹ / ₂ " x 7/8" RR Expansion Ring	



RHCNST

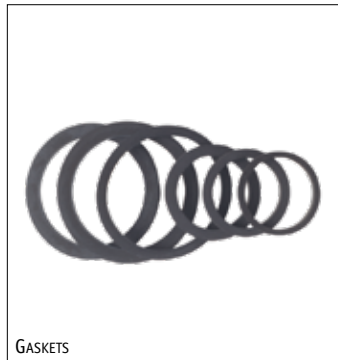

GASKETS

SINGLE JACKET HOSE COUPLINGS are made of cast brass or aluminum and come with rings and gaskets.

P/N	DESCRIPTION	BOWL SIZE
SJC15NST	1 ¹ / ₂ " NST SJ Cplgs, Brass	1 ¹³ / ₁₆ "
SJC15NPSHD	1 ¹ / ₂ " NPSH SJ Cplgs, Brass	1 ¹³ / ₁₆ "
ASJC15NST	1 ¹ / ₂ " NST SJ Cplgs, Alum	1 ¹³ / ₁₆ "
ASJC15NPSHD	1 ¹ / ₂ " NPSH SJ Cplgs, Alum	1 ¹³ / ₁₆ "
ASJC25NST	2 ¹ / ₂ " NST SJ Cplgs, Alum	2 ¹³ / ₁₆ "
SJC25NST	2 ¹ / ₂ " NST SJ Cplgs, Brass	2 ¹³ / ₁₆ "
SJTG15	SJ Tail Gasket	1 ¹³ / ₁₆ "
SJTG25	SJ Tail Gasket	2 ¹³ / ₁₆ "
SJSG15	1 ¹ / ₂ " SJ Swivel Hose Gasket	
SJSG25	2 ¹ / ₂ " SJ Swivel Hose Gasket	
SER15	1 ¹ / ₂ " x 1 ¹ / ₄ " SJ Expansion Ring	
SER25	2 ⁷ / ₁₆ " x 1 ¹ / ₄ " SJ Expansion Ring	



SJC15NST



SER15, ER15

DOUBLE JACKET HOSE COUPLINGS are made of cast brass or aluminum and come with rings and gaskets.

P/N	DESCRIPTION	BOWL SIZE
DJCNSTD	1 ¹ / ₂ " NST DJ Cplgs, Brass	1 ¹⁵ / ₁₆ "
DJCNPSHD	1 ¹ / ₂ " NPSH DJ Cplgs, Brass	1 ¹⁵ / ₁₆ "
ADJCNSTD	1 ¹ / ₂ " NST DJ Cplgs, Alum	1 ¹⁵ / ₁₆ "
DJC25NST	2 ¹ / ₂ " NST DJ Cplgs, Brass	3"
ADJC25NST	2 ¹ / ₂ " NST DJ Cplgs, Alum	3"
DJTG15	DJ Tail Gasket	1 ¹⁵ / ₁₆ "
DJTG25	DJ Tail Gasket	3"
SER15	1 ¹ / ₂ " x 1 ¹ / ₄ " DJ Expansion Ring	
DER25	2 ⁷ / ₁₆ " x 1 ¹ / ₂ " DJ Expansion Ring	
SJSG15	1 ¹ / ₂ " DJ Swivel Hose Gasket	
SJSG25	2 ¹ / ₂ " DJ Swivel Hose Gasket	



DJCNSTD



DER25, SER25

HOSE TESTERS

ELECTRIC HOSE TESTER accommodates 1½" and 2½" fire hose and can be used in wet conditions with its 120 VAC wash-down electric motor. Comes standard with quick connect adapters and can be used to meet NFPA 1962 Hose Testing Guidelines. Hose adapters sold separately, see page 45.

P/N	DESCRIPTION
DDP58589GZ	Triple Electric Hose Tester
DDP58524GZ	Cap, 1½" Hose Tester, NST
DDP58526GZ	Cap, 2½" Hose Tester, NST
DDP58585GZ	Plug, 1½" Hose Tester, NST
DDP58587GZ	Plug, 2½" Hose Tester, NST



POLYCARBONATE FIRE HOSE NOZZLES

Brooks' high-impact **POLYCARBONATE NOZZLES** are an economical alternative to the more expensive brass models and come with the same array of spray patterns—straight stream to fog. For Class A and B fires.

NOTE: Intended for firefighting use only.

P/N	DESCRIPTION
10NST	1" Adj Poly Nozzle, 30 gpm, NST
10IPT	1" Adj Poly Nozzle, 30 gpm, NPSH
15NST	1½" Adj Poly Nozzle, 78 gpm, NST
15IPT	1½" Adj Poly Nozzle, 78 gpm, NPSH
25NST	2½" Adj Poly Nozzle, 210 gpm, NST
2520NST	2½" Adj Poly Nozzle w/ Handles, 150 gpm, NST

Rated gallons per minute (gpm) at 100 psi (wide open).

Brooks high-impact **POLYCARBONATE ALL-FOG NOZZLES** are an economical alternative to the more expensive electrical brass models and come with the same array of spray patterns—full fog to shut off. For Class A, B, and C (electrical) fires.

NOTE: Intended for firefighting use only.

P/N	DESCRIPTION
E15NST	1½" All-Fog Nozzle, 78 gpm, NST
E15IPT	1½" All-Fog Nozzle, 78 gpm, NPSH

Rated gallons per minute (gpm) at 100 psi (wide open).



NOZZLE GASKETS

P/N	DESCRIPTION
B250G	2½" Nozzle Gasket, NST
GIPT	1½" Nozzle Gasket, NPSH
GNST	1½" Nozzle Gasket, NST
10G	1" NST Gasket, NST

BRASS FIRE HOSE NOZZLES

This **Underwriter's PLAYPIPE** is constructed of cast brass with red Marlin trim and a swivel handle. The discharge end is supplied with **Underwriter's** thread (2³/₁₆" ODM x 12 threads per inch). Measures 30" in length. Inlet: 2½" NST with a standard 1½" discharge tip (1¾" without tip).

P/N	DESCRIPTION
221	Playpipe

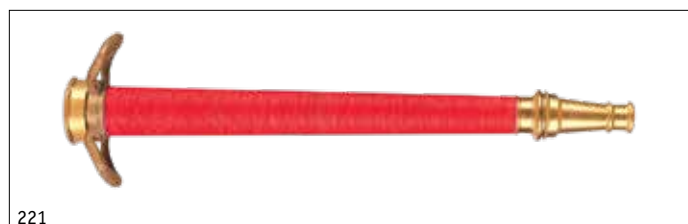

Our **BRASS STRAIGHT STREAM NOZZLE** comes with a ½" discharge at the tip for powerful sprays that reach a long way, making this 1½" x 10" NST nozzle ideal for industrial washdown. Satin brass finish.

P/N	DESCRIPTION
211N	Straight Stream Nozzle



3 FIRE HOSE, NOZZLES, BRASS, & HOSE VALVES



118I

Industrial-grade **BRASS FOG NOZZLE** are precision machined to perform flawlessly—straight stream through full fog and shutoff. Satin brass finish. UL listed for Class A and B fires and FM approved, except **114N** (UL listed only).

P/N	DESCRIPTION
118N	1" Adj Fog Nozzle, 26 gpm, NST
118I	1" Adj Fog Nozzle, 26 gpm, NPSH
113N	1½" Adj Fog Nozzle, 106 gpm, NST
113I	1½" Adj Fog Nozzle, 106 gpm, NPSH
114N	2½" Adj Fog Nozzle, 270 gpm, NST



114N



117N

Economically priced **BRASS FOG NOZZLES** are precision machined for optimum performance from shut off to full fog. Satin brass finish. UL listed for Class A and B fires and FM approved.

P/N	DESCRIPTION
117N	1½" Adj Fog Nozzle, 94 gpm, NST
117I	1½" Adj Fog Nozzle, 94 gpm, NPSH



113I

Designed specifically for electrical fires, this industrial **BRASS ALL-FOG NOZZLE** is acceptable for use on all fire classes. Satin brass finish. UL listed for Class A, B, and C (electrical) fires and FM approved.

P/N	DESCRIPTION
115N	1½" All-Fog Nozzle, 98 gpm, NST



115N



116N

BRASS PIN RACK NOZZLES are made to clip into any standard hose rack unit. They come standard with variable streams (shutoff, straight stream, and fog). Satin brass finish. UL listed for Class A and B fires.

P/N	DESCRIPTION
116N	1½" Adj Rack Nozzle, 60 gpm, NST
116I	1½" Adj Rack Nozzle, 60 gpm, NPSH

Designed for superior performance, this **HEAVY-DUTY INDUSTRIAL NOZZLE** provides straight stream through full fog and shutoff. Satin brass finish. UL listed for Class A and B fires and FM approved.

P/N	DESCRIPTION
119N	1½" Adj Heavy-Duty Nozzle, 84 gpm, NST



119N



120N

INDUSTRIAL WASHDOWN NOZZLES come standard with variable streams (shutoff, straight stream, and fog). 100 psi max operating pressure. Satin brass finish.

NOTE: For water use only, not UL listed or FM approved.

P/N	DESCRIPTION
120N	1½" Adj Washdown Nozzle, 88 gpm, NST
120I	1½" Adj Washdown Nozzle, 88 gpm, NPSH

UL rated gallons per minute (gpm) at 100 psi (wide open).

RACKS AND REELS

Brooks' semi-automatic **PIN RACKS** come pre-loaded with movable pins and an automatic release mechanism that keeps water out of the hose until the last fold is removed. Red.

NOTE: Pin rack length is measured from center of nipple opening to end of hose clip.

P/N	RACK HOSE	SJ HOSE	HOSE DIA	L	W
DMHR4UL	100'	—	1 1/2"	18"	4"
HR4FMUL	100'	—	1 1/2"	22"	4 1/4"
HR5SJ	—	100'	1 1/2"	22"	4"
HR6FMUL	100'	—	1 1/2"	19"	4 1/4"

P/N	DESCRIPTION
DMHR4UL	Pin Rack, UL/FM For Rack Hose
HR4FMUL	Pin Rack, UL/FM For Rack Hose
HR5SJ	Pin Rack For SJ Hose
HR6FMUL	Pin Rack w/ 2 1/2" Nipple Opening, UL/FM For Rack Hose

PIN RACK ACCESSORIES include wall brackets, rack nipples, nozzle clips, and extra pins for supporting and maintaining hose rack assemblies.

P/N	DESCRIPTION
FHWB	Wall Bracket For Pin Rack w/ 1 1/2" Opening
311I	1 1/2" Rack Nipple, NPT x NPSH
311N	1 1/2" Rack Nipple, NPT x NST
312N	2 1/2" Rack Nipple, NPT x NST
FOGC	Fog Nozzle Clip For Pin Rack
RPIN	Pin For Badger Powhatan Pin Rack
BPIN	Pin For Brooks & Elkhart Pin Rack

Brooks' **HEAVY-DUTY HOSE REELS** feature solid 16 ga steel sides and hubs, while the mounting hardware features a welded steel 1" x 3/16" reel bracket with a 1 1/2" x 1/4" steel wall bracket for impressive support. The wall bracket swings 180° and easily adapts to pipes (1 1/2"—3") with optional pipe bracket set **PBSET**. Each reel comes with a hook-and-loop back strap to keep hose securely wound. Red baked enamel finish.

P/N	RACK HOSE	SJ HOSE	DJ HOSE	HOSE DIA	L	H	W
HDR19	100'	75'	50'	1 1/2"	23 3/8"	19"	5 3/4"
HDR25	150'	100'	75'	1 1/2"	30"	25"	5 3/4"
HDR25HC	300'	200'	150'	1 1/2"	30"	25"	8 3/4"
HDR25HC	150'	100'	75'	2 1/2"	30"	25"	8 3/4"

P/N	DESCRIPTION
HDR19	19" Heavy-Duty Hose Reel
HDR25	25" Heavy-Duty Hose Reel
HDR25HC	25" High-Capacity, Heavy-Duty Hose Reel
PBSET	Pipe Brackets, Pkg/2 For Heavy-Duty Reels
VBSBK	Black Velcro Strap

The **FireTech™ HOSE HANGER ASSEMBLY** is constructed of aluminum alloy and conveniently accommodates 100' of lined or unlined hose (up to 2 1/2"). The top shoulder is spring loaded so that water pressure or a single pull is sufficient to release the hose. It stores hose close to walls or columns to minimize damage as well as allowing for fewer bends in the hose, prolonging its life. Mounting instructions included.

P/N	DESCRIPTION
THH	Hose Hanger Assembly



		Total Loops Of Hose		
		2	3	4
Hose Length	50'	12'	8'	6'
	75'		12'	9'
	100'			12'



FHR

Brooks' steel **ECONOMY HOSE REELS** offer quality and value in a sturdy design. They come with a 16 ga steel wall bracket that swings 180°. Red baked enamel finish.

P/N	RACK HOSE	SJ HOSE	DJ HOSE	HOSE DIA	L	H	W
FHR	100'	75'	—	1½"	23½"	18"	6½"
FHR24	150'	100'	—	1½"	29"	24"	6¼"

P/N	DESCRIPTION
FHR	18" Economy Hose Reel
FHR24	24" Economy Hose Reel



HHR1

Increase the service life of your hose with our red enameled steel **HUMP RACKS**. They provide stress-free fire hose storage by supporting the hose weight at its center, relieving strain on the folded ends and couplings.

P/N	RACK HOSE	SJ HOSE	DJ HOSE	HOSE DIA	L	H	W
HHR1	200'	100'	75'	1½"	33½"	27 ⁷ / ₈ "	4 ³ / ₈ "
HHR2	200'	100'	75'	2½"	33½"	27 ⁷ / ₈ "	5 ¹³ / ₁₆ "

P/N	DESCRIPTION
HHR1	Hump Rack For 1½" Hose
HHR2	Hump Rack For 2½" Hose



RC25 In Use

Brooks' **RACK COVERS** are made of durable vinyl to protect your hose rack assemblies from dirt and grime. They are highly visible and come with hook-and-loop closures to ensure a proper fit and easy access in an emergency.

P/N	DESCRIPTION	L X H X W
RC25	Cover, Red For Pin Rack	21" x 24" x 5"
RC25L	Cover, Red For Pin Rack	21" x 30" x 5"
RC25LS	Cover, Orange, Spanish For Pin Rack	21" x 30" x 5"
RC32	Cover, Red For Pin Rack	32" x 24" x 6"
HRC1	Cover, Red For HHR1 Hump Rack	34" x 28½" x 5"
HRC2	Cover, Red For HHR2 Hump Rack	34" x 28½" x 6¼"



RC25LS



HRC1

Brooks' **REEL COVERS** are manufactured to the same standards as our rack covers, offering a custom fit for both our **Economy** and **Heavy-Duty Hose Reels**. These durable vinyl covers are a must for protecting a hose reel investment. Red.

P/N	DESCRIPTION	L X H X W
FHRC18	Cover For FHR & HDR19 Reels	20" x 19" x 5"
FHRC24	Cover For FHR24 & HDR25 Reels	26" x 25" x 5"
FHRC24DW	Cover For HDR25HC Reel	26" x 25" x 8"



FHRC18

MUNICIPAL HAND TOOLS

Designed for today's fire department connections, this assortment of quality **WRENCHES** cover all the popular sizes and styles in storz and threaded adapters (pin or rocker lugs).

P/N	DESCRIPTION
STW	Storz x Universal Spanner, Alum Fits 4"-6" Storz & 1½"-3" Rocker Lugs
STH	Storz Spanner Wrench Holder (Empty)
W570	Universal Spanner Wrench, Alum Fits 1½"-3" Pin/Rocker Lugs
W580	Standard Hydrant/Spanner Wrench, Steel/Ductile Iron Fits 1½"-6" Pin/Rocker Lugs
W575	Heavy-Duty Hydrant/Spanner Wrench, Steel/Ductile Iron Fits 1½"-6" Pin/Rocker Lugs
K48	Hydrant/Spanner Wrench Holder (Empty)
AFS	Folding Pocket Spanner Wrench, Plastic Fits Pin/Rocker Lugs thru 4"

This collection of **MULTI-PURPOSE RESCUE TOOLS** features the **Res-Q-Rench** that is five tools in one—universal spanner, pry tool, window punch, seat belt cutter, and gas shutoff. The small but effective **Resqme®** tool easily shatters tempered glass and cuts through safety belts in seconds. A must-have for service techs and first responders alike.

P/N	DESCRIPTION
RQR	Res-Q-Rench Fits 4", 5" Storz & Rocker Lugs thru 3"
RST1	Resqme Tool

FIRE AXES and **ACCESSORIES** include some of the finest emergency entry tools available today. The discriminating professional has a choice of four different axes—with or without pick heads (all with 6 lb heads) and either solid hickory or yellow fiberglass handles. Optional mounting bracket and hooks sold separately.

P/N	DESCRIPTION
407Y*	Flat Head Fire Axe w/ 34" Fiberglass Handle
D406M	Pick Head Fire Axe w/ 36" Hickory Handle (Domestic)
D406Y	Pick Head Fire Axe w/ 36" Fiberglass Handle (Domestic)
AB408	Axe Bracket & Hook

*WHILE QUANTITIES LAST!

ADAPTERS, CAPS, AND PLUGS

Female x Male **BRASS HEXAGON ADAPTERS** are used to change threads. Rigid hexagon design in cast brass.

P/N	DESCRIPTION
711	1½" PCT(F) x 1½" NST(M) Adapter
712	1½" NPT(F) x 1½" NST(M) Adapter
713	1½" NST(F) x 1½" NPT(M) Adapter
714	1½" NPSH(F) x 1½" NST(M) Adapter
715	2½" NPT(F) x 2½" NST(M) Adapter
716	2½" NST(F) x 2½" NPT(M) Adapter

Female x Male **BRASS REDUCERS** are used to change threads or size. Pin lug design in cast brass.

P/N	DESCRIPTION
721	2½" NST(F) x 1½" NST(M) Reducer
722	2½" NPSH(F) x 1½" NST(M) Reducer
724	2½" NST(F) x ¾" GHT(M) Reducer
725	2½" NST(F) x 1½" NPSH(M) Reducer
726	1½" NST(F) x ¾" GHT(M) Reducer
727	1½" NST(F) x 1" NST(M) Reducer

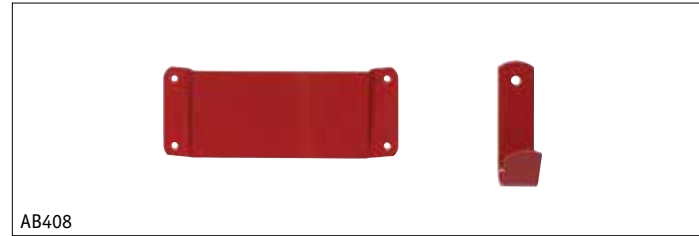
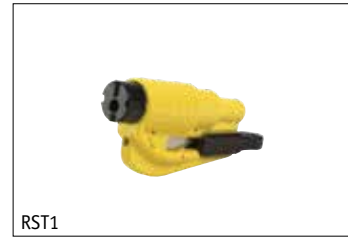
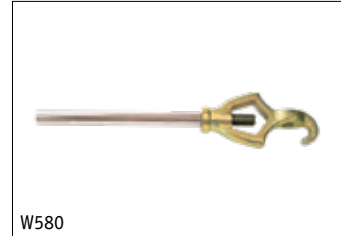

3 FIRE HOSE, NOZZLES, BRASS, & HOSE VALVES



731



B741

Male x Male **BRASS HEXAGON NIPPLES** are used to change configuration, threads, or size. Rigid hexagon design in cast brass.

P/N	DESCRIPTION
731	1 1/2" NPT(M) x 1 1/2" NST(M) Nipple
732	2 1/2" NPT(M) x 2 1/2" NST(M) Nipple
733	2 1/2" NPT(M) x 1 1/2" NST(M) Nipple

Female x Female **BRASS DOUBLE SWIVEL ADAPTERS** are used to connect two male hose threads. Dual pin lug swivel design in cast brass.

P/N	DESCRIPTION
B741	1 1/2" NST(F) x 1 1/2" NST(F) Swivel Adapter
B742	2 1/2" NST(F) x 2 1/2" NST(F) Swivel Adapter



752



761

Female x Male **BRASS HEXAGON BUSHINGS** are used to change threads or size. Rigid hexagon design in cast brass.

P/N	DESCRIPTION
751	2" NPT(F) x 2 1/2" NST(M) Bushing
752	1 1/2" NST(F) x 2 1/2" NST(M) Bushing
753	1 1/2" NST(F) x 2 1/2" NPT(M) Bushing

Female x Female **BRASS HEXAGON ADAPTERS** are used to change threads or connect two males. Rigid hexagon design in cast brass.

P/N	DESCRIPTION
761	2 1/2" NST(F) x 2 1/2" NPT(F) Hex Adapter
762	1 1/2" NST(F) x 1 1/2" NPT(F) Hex Adapter
763	1 1/2" NST(F) x 1 1/2" NST(F) Hex Adapter



811PB



822

Female x Female **BRASS SNOOTS** are used to connect to flush inlet connections. Rigid hexagon design with pin lug swivel in cast, polished, or chrome-plated brass.

P/N	DESCRIPTION
811	2 1/2" NPT(F) x 2 1/2" NST(F) Snoot, Cast
811PB	2 1/2" NPT(F) x 2 1/2" NST(F) Snoot, Polished
811PC	2 1/2" NPT(F) x 2 1/2" NST(F) Snoot, Chrome



511N

Female x Male **BRASS SNOOTS** are used to connect to flush hydrant connections. Rigid hexagon design with pin lug swivel in cast brass.

P/N	DESCRIPTION
821	2 1/2" NST(F) x 2 1/2" NPT(M) Snoot
822	1 1/2" NST(F) x 1 1/2" NPT(M) Snoot



512N

BRASS CAPS & CHAINS are used on fire department connections, hydrants, valves, etc., to hold back water. Pin lug design in cast, polished, or chrome-plated brass.

P/N	DESCRIPTION
511I	1 1/2" NPSH Cap, Cast
511N	1 1/2" NST Cap, Cast
511NPB	1 1/2" NST Cap, Polished
511NPC	1 1/2" NST Cap, Chrome
512N	2 1/2" NST Cap, Cast
B512N	2 1/2" NST Cap, Cast (Domestic)
512NPB	2 1/2" NST Cap, Polished
512NPC	2 1/2" NST Cap, Chrome
512NPCRL	2 1/2" NST Cap, Chrome, Rocker Lug

BRASS PLUGS & CHAINS are used on fire department inlet connections to keep inlet ports free of debris. Pin lug design in cast, polished, or chrome-plated brass.

P/N	DESCRIPTION
513N	2 1/2" NST Plug, Cast
513NPB	2 1/2" NST Plug, Polished
513NPC	2 1/2" NST Plug, Chrome
513NPCRL	2 1/2" NST Plug, Chrome, Rocker Lug
514N	1 1/2" NST Plug, Cast

PLASTIC CAPS & CHAINS are an inexpensive way to protect hydrant threads and a viable replacement for brass caps when theft is an issue. Models **B150** and **B250** thread on, while the **U250** pushes/pulls on and off. Red.

P/N	DESCRIPTION
B150IPT	1 1/2" NPSH Plastic Cap
B150NST	1 1/2" NST Plastic Cap
B250	2 1/2" NST Plastic Cap
U250	2 1/2" Universal Plastic Cap
B250G	Gasket For B250

Our **ALUMINUM BREAK CAPS** serve the same function as the brass and plastic caps. But instead of screwing or pushing/pulling on and off, they are easily broken with a hydrant/spanner wrench. Caps attach to inlets, courtesy of two eye bolts that slip over pin lugs. Pkg/2.

P/N	DESCRIPTION
ABCA	2 1/2" Alum Break Caps, Silver
ABCR	2 1/2" Alum Break Caps, Red

The most economical way to protect fire department connection inlets is with **PLASTIC BREAK CAPS**. Choose either the **PAC**, which uses an adjustable bar that threads onto any hose thread, or the **PBC2**, which uses eye bolts to secure the cap via the inlet's pin lugs. Both fit 2 1/2" inlets and are easily broken with a hydrant/spanner wrench. Red.

P/N	DESCRIPTION
PAC	Adjust-A-Plug
PBC2	Plastic Break Caps w/ Eye Bolts, Pkg/2

HOSE VALVES

Precision-made **GATED WYE LEADER LINE SIAMESE** come with ball valves built into the body so that either lead can be used independently of the other. **Gated Wyes** feature 2 1/2" NST female swivel inlets and 1 1/2" male outlets in two different threads. Other features include cast brass bodies, painted red with polished-chrome trim, and rocker lug swivels.

NOTE: Not recommended for charged pre-connected hose lines!

P/N	DESCRIPTION
611	Gated Wye, NST (Outlets)
611NPSH	Gated Wye, NPSH (Outlets)



513N, 514N

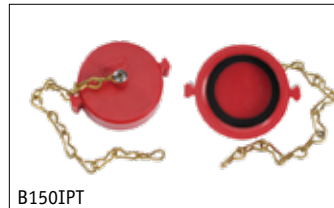

B150IPT



U250

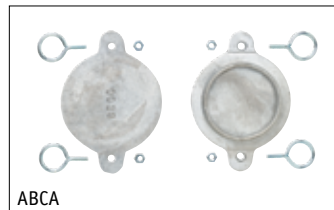

ABCA

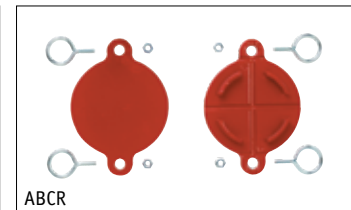

ABCR



ABCR In Use



PAC



PBC2



611

3 FIRE HOSE, NOZZLES, BRASS, & HOSE VALVES



Engineered for trouble-free operation, these **ANGLE HOSE VALVES** are designed for use with hose storage devices and hydrants. Each valve has a 300 lb rating and is UL listed and FM approved. Constructed of cast brass with red or silver handwheels.

P/N	DESCRIPTION	EACH
411	1 1/2" NPT(F) x 1 1/2" NPT(F) Angle Valve, Red	
B411	1 1/2" NPT(F) x 1 1/2" NPT(F) Angle Valve, Silver (Domestic)	
412	2 1/2" NPT(F) x 2 1/2" NPT(F) Angle Valve, Red	
413	1 1/2" NPT(F) x 1 1/2" NST(M) Angle Valve, Red	
414	2 1/2" NPT(F) x 2 1/2" NST(M) Angle Valve, Red	
B414	2 1/2" NPT(F) x 2 1/2" NST(M) Angle Valve, Silver (Domestic)	
415	1 1/2" NPT(F) x 1 1/2" NPSH(M) Angle Valve, Red	



PRESSURE REDUCING ANGLE HOSE VALVES can be adjusted to restrict pressures up to 175 lb and come with locking pin devices that restrict full opening by untrained personnel. Pin may be removed by fire personnel for unrestricted operation in emergencies. UL listed. Cast brass construction with red handwheels.

P/N	DESCRIPTION
421	1 1/2" NPT(F) x 1 1/2" NPT(F) PR Valve
422*	2 1/2" NPT(F) x 2 1/2" NPT(F) PR Valve
423	1 1/2" NPT(F) x 1 1/2" NST(M) PR Valve
424	2 1/2" NPT(F) x 2 1/2" NST(M) PR Valve

*WHILE QUANTITIES LAST!



Heavy-duty **GATE VALVES** are designed for use on pump test headers and dry systems as a fire hose connection. Valves feature straightway patterns and come with caps and chains. Other features include solid wedge discs with tapered seats and 300 lb ratings. UL listed and FM approved. Cast brass construction with red handwheels.

P/N	DESCRIPTION
433	2 1/2" NPT(F) x 2 1/2" NST(M) Gate Valve
434	3" NPT(F) x 2 1/2" NST(M) Gate Valve

SINGLE HYDRANT GATE VALVES are used on fire hydrant outlets for slow and precise control of flow (throttling). Solid brass valves feature metal-to-metal seats and non-rising stems. They come standard in straightway patterns and with 300 lb ratings.



P/N	DESCRIPTION
443	2 1/2" NST(F) x 2 1/2" NST(M) Gate Valve w/ Swivel
B443	2 1/2" NST(F) x 2 1/2" NST(M) Gate Valve w/ Swivel (Domestic)

VALVE REPLACEMENT PARTS. Red handwheels fit **Giacomini** valves; silver handwheels fit **Powhatan**.

P/N	DESCRIPTION
PHW15	Handwheel For Powhatan 1 1/2" Valve
PHWN15	Handwheel Nut For Powhatan 1 1/2" Valve
GHW15	Handwheel For Giacomini 1 1/2" Valve
PHW25	Handwheel For Powhatan 2 1/2" Valve
PHWN25	Handwheel Nut For Powhatan 2 1/2" Valve
GHW25	Handwheel For Giacomini 2 1/2" Valve
GHWN	Handwheel Nut For Giacomini Valve
GSRS15	Rubber Seal For Giacomini 1 1/2" Angle Valve
PSRS15	Rubber Seal For Powhatan 1 1/2" Angle Valve
PSRS25	Rubber Seal For Powhatan 2 1/2" Angle Valve



REPLACEMENT PARTS



4

EMERGENCY RESPONSE PRODUCTS

Tough As The Job They're Designed For



5009XL

Offering quality and economy, **Shelby's GENERAL PURPOSE GLOVES** are made from wash-and-wear tan pigskin for extra toughness. Gunn cut with **Kevlar®** thread, they have seamless palms, wing thumbs, and **Nomex®** wristlets for extra flame resistance. Meets CAL and Federal OSHA requirements.

P/N	DESCRIPTION	SIZE
5009L	General Purpose Gloves	LG
5009XL	General Purpose Gloves	XL



2500L

PROTECTIVE GEAR

With the help of **Kevlar** and **Armortex**, **ProFlex® FIRE & RESCUE PERFORMANCE GLOVES**, from **Ergodyne**, can be used for extrication rescues and other jobs that push the limits of endurance. They are reinforced at the fingertip gripping zones to retain a tighter hold. EVA padding cuts down on shock and impact to the hands, while stretchable spandex shells make them comfortable to wear. CE EN388 4243. Lime/Black.

P/N	DESCRIPTION	SIZE
2500M	Fire & Rescue Gloves	MD
2500L	Fire & Rescue Gloves	LG
2500XL	Fire & Rescue Gloves	XL



5228GFDP

Shelby® STRUCTURAL FIREFIGHTING GLOVES are made of fire-retardant, heat-resistant, heavyweight **Koala®** tanned cowhide for maximum performance. They are sewn with **Kevlar®** thread, have fleece liners, and use **Gore** glove barrier fabric to keep them thermally stable. Other features include wing thumbs, wraparound index fingers, gauntlets, and **Shelby FDP** ("Fit + Durability = Performance"). Gunn cut. Meets NFPA 1971. Midnight Blue.

P/N	DESCRIPTION	SIZE
5228GFDP	Firefighting Gloves	SM
5228GFDPM	Firefighting Gloves	MD
5228GFDP	Firefighting Gloves	LG
5228GFDPXL	Firefighting Gloves	XL

Ergodyne's hi-vis GloWear® PUBLIC SAFETY VESTS

feature two-tone, five-point breakaway designs with Level 2 ANSI-compliant tape set on 4½" contrasting color backgrounds. They come with one multi-division pocket on the inside and radio tabs/holders. Used for operations at local, state, and federal levels, these vests help quickly identify people working in emergency response. ANSI 207 compliant. Lime.

P/N	DESCRIPTION	SIZE
PSV1	Public Safety Vest	LG/XL
PSV2	Public Safety Vest	2XL/3XL
PSV3	Public Safety Vest	4XL/5XL



PSV1

The **Cobra™ Classic™ FIREFIGHTING HOOD**, from **PGI**, offers serious protection without sacrificing comfort. The hood accomplishes this by blending **Nomex/Lenzing FR** for superior flame and heat resistance with a **Comfort-Plus™** liner for unbeatable breathability, comfort, and moisture-wicking properties. Flat stitched seams won't bunch or dig into your skin, and its extra-heavyweight elastic face opening stretches to a full 16" for easy donning and a snug fit—with or without an SCBA mask. Coverage extends to lower neck. UL classified to NFPA 1971. One size. White.

P/N	DESCRIPTION
BZ33	Firefighting Hood



BZ33

From **Bullard**, the **PX Series FIREFIGHTING HELMET** offers life-saving head protection in a thermoplastic design for optimum impact and penetration resistance. Reliable, under repeated heat exposure, it comes standard with the **Sure-Lock®** ratchet headband suspension for easy adjustment and superior comfort and an optically correct face shield. Certified to NFPA 1971 Standard on Protective Ensembles for Structural Fire Fighting. Yellow.

P/N	DESCRIPTION
PXY	Firefighting Helmet



PXY

Designed for wildland firefighting and technical rescue operations **StrikeTeam XTO™ GOGGLES** are an ideal choice for numerous other situations requiring dependable eye protection. They come with a **Speed-Clip™** quick strap adjustment, face padding, and a replaceable clear lens and tear-off covers. They are nearly indestructible, thanks to polycarbonate construction, and fog-free with full-filter ventilation. Goggles will fit over most eyeglasses and are ANSI Z87.1 and NFPA 1500 compliant. Black frame, clear lens.

P/N	DESCRIPTION
ESS1	XTO Goggles



ESS1

4 EMERGENCY RESPONSE PRODUCTS



LBB10

Black Diamond® 16" RUBBER FIRE BOOTS offer incredible comfort with stitched-down linings that do not pull out. Their nonslip heels offer a better, more accurate fit, while their lower midsoles are coated with 9.5 mm felt for added comfort. Other standard features include steel toes and shanks for added protection and lug outsoles for a better purchase on all types of terrain. Boots are open cell foam insulated and meet or exceed NFPA 1971, ANSI Z41, and CSA Z195 requirements. Medium width.

P/N	DESCRIPTION	SIZE
LBB8	16" Insulated Fire Boots	8
LBB9	16" Insulated Fire Boots	9
LBB95	16" Insulated Fire Boots	9.5
LBB10	16" Insulated Fire Boots	10
LBB11	16" Insulated Fire Boots	11
LBB12	16" Insulated Fire Boots	12
LBB13	16" Insulated Fire Boots	13
LBB14	16" Insulated Fire Boots	14

ACCESSORIES

P/N	DESCRIPTION
HBS	Fully Adjustable, Red "H" Back Suspenders
LGB	Firefighter's Gear Bag, Heavy-Duty, Water-Resistant Nylon, 27"L x 18"H x 12"W



HBS



LGB

PUBLIC SAFETY LIGHTING

Streamlight's KEYMATE is big on power, thanks to its high-intensity LED that lasts 100,000 hours. Its anodized aluminum casing is virtually indestructible, while four high-capacity alkaline button cell batteries (included) power it for up to 96 hours. 2³/₁₆". Black.

P/N	DESCRIPTION
SL72001	KeyMate Flashlight 10 Lumens; 96 hr Runtime
SL72030	KeyMate Replacement Batteries, Pkg/4



SL72001



73001SL

Super bright, **Streamlight's NANO LIGHT** is made from aircraft-grade aluminum for extra toughness. It provides up to eight hours of run time, with a 100,000-hour white LED, on four coin cell batteries (included). Comes with a clip to attach it to a key chain, a tool belt, and more. 1¹/₂". Black.

P/N	DESCRIPTION
73001SL	Nano Flashlight 10 Lumens; 8 hr Runtime



P1810R

Pelican's LED KEYCHAIN LIGHTS are lightweight with aluminum construction and twist-on activation. They are IPX4 water resistant and come with four coin cell batteries. Lights offer 16 lumens and 8-hour runtimes. 1¹/₂".

P/N	DESCRIPTION
P1810BK	Keychain Light, Black
P1810BL	Keychain Light, Blue
P1810R	Keychain Light, Red

Rechargeable Or Alkaline

The bright, right-angled **Survivor® LED FLASHLIGHT**, from **Streamlight**, is a lightweight, hand-held flashlight designed for use in hazardous situations. It uses **C4®** LED technology for exceptional power. The **Survivor** LED is IPX4 water resistant and has microprocessor-controlled High and Low lighting modes as well as a Moonlight and Emergency Flash mode. 175 lumens (High mode). 7¹/₁₆"L x 2⁷/₈"H x 2⁷/₈"W.

P/N	DESCRIPTION
SL90513	Survivor LED Flashlight, Rechargeable, Yellow Includes: 120 VAC, 12V Steady Charger; 13 hr Runtime (Low Mode)
SL90503	Survivor LED Flashlight, Rechargeable, Orange Includes: 120 VAC, 12V Steady Charger; 13 hr Runtime (Low Mode)
SL90500	Survivor LED Flashlight (Only), Rechargeable, AC/DC, Orange 13 hr Runtime (Low Mode)
SL90541	Survivor LED Flashlight (Only), Alkaline, Yellow 15 hr Runtime (Low Mode)
SL90540	Survivor LED Flashlight (Only), Alkaline, Orange 15 hr Runtime (Low Mode)



SL90503

The **E-Spot® Litebox® RECHARGEABLE LANTERN**, from **Streamlight**, features three shockproof **C4®** LEDs with a 50,000-hour life, while jumper selectable High and Low settings allow more light output or longer run time. It is tough, too, thanks to ABS thermoplastic construction with a rubberized impact bumper, lens ring, and cushioned grip handle. IPX4 water resistant. 11¹/₂"L x 7"H x 5³/₃₂"W. Orange/Black.

P/N	DESCRIPTION
SL45851	Litebox Standard System Flashlight Includes: 120 VAC, 12V Chargers, Shoulder Strap & Mounting Rack; 540 Lumens (High Mode); 15 hr Runtime (Low Mode)
PRB612	6V, 12 Ah Battery For SL45851



SL45851

Just like **Streamlight's Litebox**, these **E-Spot® Firebox® RECHARGEABLE LANTERNS** come with three shockproof **C4®** LEDs that offer 50,000 hours of service. Jumper selectable High and Low settings are standard as are ABS thermoplastic housings, rubberized impact bumpers, lens rings, cushion-grip handles, and toggle switches for easy operation with gloves. Where **Firebox** lights differ is with their extremely bright blue taillights—Steady On or Blinking. IPX4 water resistant. 11¹/₂"L x 7"H x 5¹/₈"W.

P/N	DESCRIPTION
SL45861	Firebox Standard System Flashlight, Orange/Black Includes: 120 VAC, 12V Chargers, Shoulder Strap & Mounting Rack; 540 Lumens (High Mode); 15 hr Runtime (Low Mode)
SL45877	Firebox Standard System Flashlight, Yellow/Black Includes: 120 VAC, 12V Chargers, Shoulder Strap & Mounting Rack; 540 Lumens (High Mode); 15 hr Runtime (Low Mode)
PRB612	6V, 12 Ah Battery For SL45861 & SL45877



SL45861



SL45877



SL68202

Streamlight's 4AA ProPolymer® LED CLASS I, DIVISION 1 FLASHLIGHT is waterproof, tough, and dependable. This non-conductive flashlight features super-bright LEDs as well as a non-slip grip and polymer case. Uses four AA-cell alkaline batteries (included). 6½". Yellow/Black.

P/N	DESCRIPTION
SL68202	ProPolymer Flashlight 67 Lumens; 155 hr Runtime
TFAAB	AA Alkaline Batteries, Pkg/4
E91BP4	Max AA Alkaline Batteries, Pkg/4



SL65018

Streamlight® Stylus® PENLIGHTS clip to your shirt pocket and feature a 100,000-hour LED that you can switch from Constant-On to Momentary Blink with the click of a button. Durably built, they have knurled anodized aluminum bodies and are IPX4 water resistant. Uses three AAAA-cell batteries (included). Black.

P/N	DESCRIPTION
SL65018	Stylus Penlight, 6¾"
	11 Lumens; 24 hr Runtime
SL65618	Stylus Reach Penlight, 14" (Extended), 6¾" (Retracted)
	11 Lumens; 24 hr Runtime
SL65030	Replacement AAAA Batteries, Pkg/6



SL65618

Energizer's Vision LED HEADLIGHT offers hands-free operation with two light modes that control brightness and runtime, making it up to four-times brighter than standard LEDs. It comes with a pivoting head, slide switch, and three AAA batteries. Impact resistant to 1 m. 1⅝". Blue.

P/N	DESCRIPTION
HDA32E	Vision Headlight 100 Lumens; 7 hr Runtime
TFAAAB	AAA Alkaline Batteries, Pkg/4



HDA32E

Streamlight's Trident® and Enduro® LED HEADLAMPS

provide superior hands-free lighting. The **Trident Headlamp** features four LEDs (one being a **C4**), a 90° tilting head, and three-way lighting for short, medium, and long distances (with Spot-to-Flood adjustment). The lightweight **Enduro Headlamp** features High and Low lighting modes, a 0.5 W high-flux LED, and O-ring sealed construction. Both headlamps have polycarbonate bodies and adjustable elastic/rubber combo head straps. **Trident** is IPX4 water resistant. **Enduro** is IPX7 waterproof to 1m for 30 minutes. And each is impact resistant to 2 m. Three AAA batteries included.



SL61050

P/N	DESCRIPTION
SL61050	Trident LED Headlamp, Orange/Black/Yellow, 1⅞"
	80 Lumens (High Mode); 53 hr Runtime (Low Mode)
SL61400	Enduro LED Headlamp, Black, 1⅝"
	50 Lumens (High Mode); 25 hr Runtime (Low Mode)
TFAAAB	AAA Alkaline Batteries, Pkg/4



SL61400

 For Replacement Batteries, See Section 10.

Energizer's Vision HD PERFORMANCE METAL FLASHLIGHT comes with custom optics for exceptional direct and peripheral vision and is LED color aligned with natural daylight. It also comes standard with **One-Touch Digital Focus** and digital switching for High, Power-Saver, and Emergency Strobe modes. Made of commercial-grade aluminum alloy and includes six AA **Energizer® Max®** batteries. IPX4 water resistant and impact resistant to 1 m. Black.

P/N	DESCRIPTION
→ EPMZH61E	Vision HD Performance Metal Flashlight 1300 Lumens; 4 hr Runtime
TFAAB	AA Alkaline Batteries, Pkg/4

In a class by itself, the compact, super-bright **Stinger® FLASHLIGHT**, from **Streamlight**, is a lightweight, rechargeable, personal light that is virtually indestructible. Offering superior materials and craftsmanship, it is even serialized for positive identification. Standard features also include an LED charge-continuity indicator; a snap-in, universal-mount charger; and an anti-roll ring to keep it where you lay it. Its nickel-cadmium battery recharge up to 1000 times as well. IPX4 water resistant and impact resistant to 1 m. Black.

P/N	DESCRIPTION
→ SL75713	Stinger LED Flashlight w/ AC/DC Charger, 2 Holders 400 Lumens (High Mode); 7.25 hr Runtime (Low Mode)
SL75175	Replacement Battery For SL75713

This **EMERGENCY LIGHTING STATION**, from **Pelican**, is a self-contained photoluminescent beacon and flashlight, housed in a clear tamperproof case that is wall mountable. When mounted, (hardware included) it offers easy access during power outages and has a **Signaling** mode for search and rescue scenarios. Uses three AA-cell alkaline batteries (included). IPX8 submersible to 1 m. 6 1/8".

P/N	DESCRIPTION
P3310ELS	Lighting Station 378 Lumens (High Mode); 202 hr Runtime (Low Mode)
TFAAB	AA Alkaline Batteries, Pkg/4

BARRICADE TAPES

Our quality selection of **BARRICADE TAPE** is made of 2.5 mil polyethylene and comes in 3" x 1000' rolls for easy handling and storage. It can be tied, stapled, or nailed in place to secure sensitive areas and warn of physical hazards or dangerous situations. Yellow.

P/N	DESCRIPTION
SLYFL	"Fire Line Do Not Cross"
SLYPL	"Police Line Do Not Cross"
TH1000	Tape Holder
TH42003	Barricade Tape Dispenser

 For Additional Warning Tapes, See Section 5.



→ **NEW**

EPMZH61E



→ **NEW**

SL75713



P3310ELS

P3310ELS In Use



SLYFL



TH1000 In Use



TH42003 w/ SLYPL In Use



DJ50ANST



DJ50YHANST



FH150ANST



BH150ANST



CG25



HH26



HK25

MUNICIPAL FIRE HOSE AND FITTINGS

Get the ultimate in high-performance with municipal-grade fire hose from **Brooks**. These durable **DOUBLE JACKET** and **YELLOW COATED FIRE HOSES** are constructed of 100% high-tensile-strength polyester yarns—both warp and filler—and lined with a high-tech E.P.D.M. tube, so they weigh less but last longer. Aluminum NST coupled.

P/N	DESCRIPTION	BOWL SIZE	WEIGHT COUPLED
DJ50ANST	50' x 1 1/2", DJ Hose	1 15/16"	18 lb
DJ2550ANST	50' x 2 1/2", DJ Hose	3"	34 lb
DJ50YHANST	50' x 1 1/2", YC Hose	1 15/16"	21 lb
DJ2550YHANST	50' x 2 1/2", YC Hose	3"	39 lb

This lightweight **FORESTRY HOSE** meets the USDA-US Forest Service Specification. Proof test pressure is 500 psi and service test is 250 psi. Aluminum NST coupled.

P/N	DESCRIPTION	BOWL SIZE	WEIGHT COUPLED
FH150ANST	50' x 1", Forestry Hose	1 1/4"	7 lb
FH1100ANST	100' x 1", Forestry Hose	1 1/4"	11 lb

Designed for structural, vehicle, grass, and forestry firefighting, **Reel Lite BOOSTER HOSE** features single jacket construction from virgin spun polyester warp yarn that is woven in a twill weave. Polyurethane lined, it is **Wear Guard** treated for extra toughness. Hose has a proof test pressure of 600 psi and a service test of 300 psi. Aluminum NST coupled. Meets NFPA 1961.

P/N	DESCRIPTION	BOWL SIZE	WEIGHT COUPLED
BH150ANST	50' x 1", Booster Hose	1 1/2"	30 lb
BH1100ANST	100' x 1", Booster Hose	1 1/2"	60 lb

For Additional Hose Options, See Section 3.

Our selection of **HYDRAULIC TEST EQUIPMENT** features a variety of highly engineered products and instruments to handle your calculation needs. The **Line** and **Cap Gauges** are easy to attach to hydrants, valves, etc., and provide a quick check of water pressure. The handheld **Pitot Gauge** and **Hydrant Test Kit** offer convenient methods of checking straight tip nozzle and hydrant pressures quickly and accurately.

P/N	DESCRIPTION
CG25	Cap Gauge (0–300 psi), 2 1/2" NST
LG25	Line Gauge (0–300 psi), 2 1/2" NST
HH26	Pitot Gauge (0–160 psi)
HK25	Hydrant Test Kit (0–160 psi), 2 1/2" NST

MUNICIPAL HAND TOOLS

Designed for today's fire department connections, these popular **WRENCHES** cover a variety of sizes in both storz and threaded adapters (pin or rocker lugs).

P/N	DESCRIPTION
STW	Storz x Universal Spanner, Alum Fits 4"-5" Storz & 1½"-3" Rocker Lugs
STH	Storz Spanner Wrench Holder
W570	Universal Spanner Wrench, Alum Fits 1½"-3" Pin/Rocker Lugs
W580	Standard Hydrant/Spanner Wrench, Steel/Ductile Iron Fits 1½"-6" Pin/Rocker Lugs
W575	Heavy-Duty Hydrant/Spanner Wrench, Steel/Ductile Iron Fits 1½"-6" Pin/Rocker Lugs
K48	Hydrant/Spanner Wrench Holder (Only)
AFS	Folding Pocket Spanner Wrench, Plastic Fits Pin/Rocker Lugs thru 4"

This collection of **MULTI-PURPOSE RESCUE TOOLS** features the **Res-Q-Rench** that is five tools in one—universal spanner, pry tool, window punch, seat belt cutter, and gas shutoff. The small but effective **ResqMe®** tool easily shatters tempered glass and cuts through safety belts in seconds. A must-have for service techs and first responders alike.

P/N	DESCRIPTION
RQR	Res-Q-Rench Fits 4", 5" Storz & Rocker Lugs thru 3"
RST1	ResqMe Tool

These **RESCUE TOOLS**, from **Channellock**, have a spanner wrench that works on storz and rocker lug couplings (up to 5"). There is also a tool steel punch to shatter safety glass, a pry bar for doors and windows, a gas shutoff, and a cable cutter with hardened steel edges that easily shear through soft metal or battery cables. Their narrow profiles are ideal for tight places.

P/N	DESCRIPTION
TL87	9" 87 Rescue Tool
TL89	11" 89 Rescue Tool

Our collection of municipal-grade **FIRE AXES** includes four different styles with or without pick heads and solid hickory or yellow fiberglass handles—all with 6 lb heads. Optional mounting bracket and hooks available separately.

P/N	DESCRIPTION
407Y*	Flat Head Fire Axe w/ 34" Fiberglass Handle
D406M	Pick Head Fire Axe w/ 36" Hickory Handle (Domestic)
D406Y	Pick Head Fire Axe w/ 36" Fiberglass Handle (Domestic)
D407M	Flat Head Fire Axe w/ 36" Hickory Handle (Domestic)
AB408	Axe Bracket & Hook

*WHILE QUANTITIES LAST!

MUNICIPAL VALVES

Gated Wye and **Swivel Gate MUNICIPAL VALVES** are engineered from lightweight cast aluminum with powder-coated bodies and hard anodized extruded aluminum inlets/outlets for maximum performance and corrosion resistance. The **Gated Wye** also has powder-coated handles with an orange peel finish for easy gripping, while the **Swivel Gate Valve** features a non-rising stainless steel stem with aluminum hand crank for fast, trouble-free operation.

P/N	DESCRIPTION
9443	2½" NST(F) x 2½" NST(M) Alum Swivel Gate Valve
9611	2½" NST(F) x 1½" NST(M) x 1½" NST(M) Alum Gated Wye



STW



W570

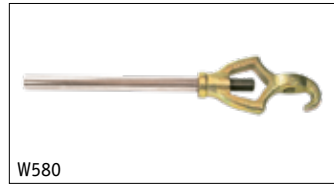

W580



W575



K48 IN USE



AFS



RQR



RST1



TL89



D406M



AB408



9443



9611

In Use photos may show items not included or available separately.



SG3012



P45SV



POK1448

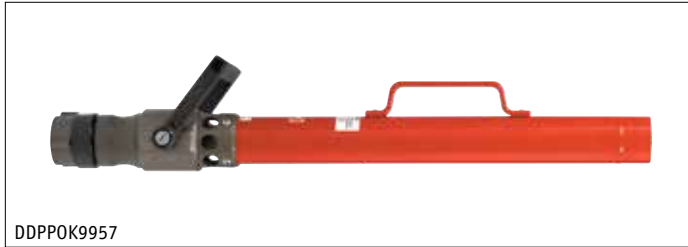

DDPPOK9957



WBES45



36AFFF



3AFFF



6AFFF



AFOAM

MUNICIPAL NOZZLES AND FOAM EDUCTORS

Brooks' collection of **Viper FIREFIGHTING NOZZLES** includes the very best municipal nozzles available. Offered in a variety of styles, sizes, and construction, these nozzles are the professional's choice for municipal and industrial applications.

Standard Features

- E-Lite aluminum construction with brass internal parts
- Fog-to-straight stream with a twist of the bumper
- Flushable without shutting down
- Full-time NST swivels and removable pistol grips
- Constant flow through fog and straight stream

P/N	DESCRIPTION
SG3012	1 1/2" Viper Nozzle, Select gal, 30, 60, 95, 125 gpm
P45SV	1 1/2" Viper Nozzle, Constant Flow, 95 gpm

POK's IN-LINE EDUCTORS are easy to install and feature a metering knob for easy economical dispersal of 0–6% foam solutions. They are simple to maintain and have a low-pressure drop. Eductors come complete with a 10' pick-up tube and an NST inlet.

P/N	DESCRIPTION
POK1448	1 1/2" Foam Eductor, 95 gpm
POK1444	1 1/2" Foam Eductor, 125 gpm

The **POK LOW EXPANSION FOAM NOZZLE** is made of aluminum with a red **NITUFF™** finish. This 8" NST nozzle provides excellent reach and penetration with an expansion ratio of 10.

P/N	DESCRIPTION
DDPPOK9957	1 1/2" Air ASP Foam Nozzle, 95 gpm

BACKPACK EXTINGUISHING SYSTEM

The **Genfo-45 WILDLAND BACKPACK EXTINGUISHING SYSTEM** features a large 4.5 gal reservoir and internal baffle for a substantial yet stable transportable water supply. It also includes a double-action hand pump and a 40" x 1/4" hose with a fully adjustable nozzle, a carry handle, and shoulder straps for easy transportation. Weighs 4 lb empty and measures 25 1/2"H x 19 3/16"W x 1"D.

P/N	DESCRIPTION
WBES45	Genfo-45 Water Backpack
WBES45FT	Genfo-45 Foam Application Tube

CHEMICAL

Brooks carries a wide selection of **FOAM** products to meet your specific needs. The **36AFFF** is all-synthetic film-forming foam, designed for use on water-soluble polar solvents and water-insoluble hydrocarbon flammable liquids. The **3AFFF** and **6AFFF** are synthetic aqueous film-forming foam concentrates, designed for use on non-polar hydrocarbon hazards. 5 gal pails.

NOTE: TFOAM is for live fire-training sessions only.

P/N	DESCRIPTION
36AFFF	3% or 6% AR-AFFF Foam
3AFFF	3% AFFF Foam
6AFFF	6% AFFF Foam
TFOAM	3% or 6% AFFF Virtual Training Foam
AFOAM	Class A Foam



CS

PERSONAL PROTECTION & SAFETY PRODUCTS



→ NEW

NFPA1018



NFPA1717

CODES AND REGULATIONS

For nearly a century, people have relied on **NFPA® PUBLICATIONS**—your blueprints to safety.

P/N	DESCRIPTION
→ NFPA1018	NFPA 10: Standard for Portable Fire Extinguishers, 2018 ed
NFPA1717	NFPA 17: Standard for Dry Chemical Extinguishing Systems, 2017 ed
NFPA17A17	NFPA 17A: Standard for Wet Chemical Extinguishing Systems, 2017 ed
NFPA9617	NFPA 96: Standard for Ventilation Control & Fire Protection of Commercial Cooking Operations, 2017 ed
→ NFPA10118	NFPA 101: Life Safety Code, 2018 ed
NFPA7216	NFPA 72: National Fire Alarm and Signaling Code, 2016 ed
NFPA196314	NFPA 1963: Standard for Fire Hose Connections, 2014 ed
→ NFPA196218	NFPA 1962: Standard for the Care, Use, Inspection, Service Testing, and Replacement of Fire Hose, Couplings, Nozzles, and Fire Hose Appliances, 2018 ed
NFPA1316	NFPA 13: Standard for the Installation of Sprinkler Systems, 2016 ed

CODE OF FEDERAL REGULATIONS, TITLE 49,

Parts 100–185, as required for all DOT testing shops and persons transporting hazardous materials (including fire extinguishers). This manual is printed every spring and includes all changes through October 1st of the previous year.

P/N	DESCRIPTION
→ DOT17	DOT CFR, Title 49

CODE OF FEDERAL REGULATIONS, TITLE 29,

OSHA, Parts 1901.1–1910.999 and 1910.1000–End. Revised July 1, 2017, and covers OSHA's general industry safety and health standards for the workplace, including lockout/tagout, confined space entry procedures, personal protective equipment, fire extinguishers, permissible exposure limits, first aid, and procedures for recording and reporting injuries and illnesses.

P/N	DESCRIPTION
→ CFR2917	2017 CFR, Title 29 (2-Volume Set)

2016 **EMERGENCY RESPONSE GUIDEBOOK** meets DOT 49CFR, section 172.602 requirement. Any person transporting hazardous materials must carry one of these (or all material safety data sheets pertaining to materials being transported in the vehicle).

P/N	DESCRIPTION
ERGB	Emergency Guidebook

FEDERAL MOTOR CARRIER SAFETY REGULATIONS,

Parts 40, 380, 382, 383, 387, 390–397, and 399. This book applies to any vehicle required to placard or any vehicle with a gross weight rating of 26,000 lb or higher. Also necessary to meet driver training requirement in DOT 49CFR, section 177.816.

P/N	DESCRIPTION
FMCSR	Federal Motor Carrier Regulations

Pocket-sized **Brooks COMPLIANCE GUIDE** summarizes the most common NFPA Standards and OSHA Regulations found in our industry. Complete with product recommendations for specific standard, code, and regulation titles. Also available as an App.

P/N	DESCRIPTION
BCG	Compliance Guide

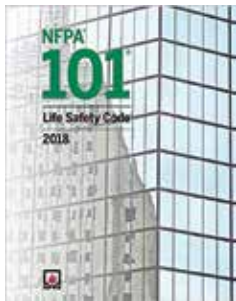

→ NEW

NFPA10118

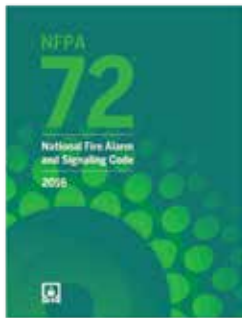

NFPA7216



→ NEW

DOT17

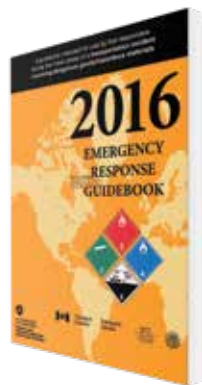

ERGB

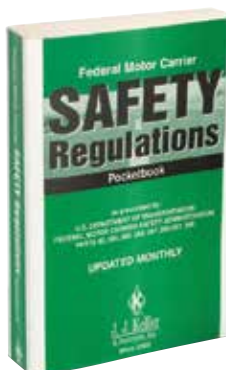

FMCSR



BCG

DOT SUPPLIES

VEHICLE INSPECTION REPORTS, as required by 49CFR, sections 396.11 and 396.13. These are three-part carbon forms, consecutively numbered, measuring 9½" x 5½". Pkg/100.

P/N	DESCRIPTION
VIR100	Vehicle Reports

Dry erase **SHIPPING DOCUMENT** is pre-printed with the most common materials to meet 49CFR requirements, section 177.817. Updated to match most recent DOT changes.

P/N	DESCRIPTION
HMSPDE	Shipping Document
RDEP	Red Dry Erase Pen

Vinyl **SHIPPING PAPER DOOR POUCH** meets shipping paper accessibility requirement (49CFR, section 177.817). Includes snaps for door attachment and measures 15" x 10½". Department of Transportation requires that, "When the driver is not at the vehicle controls, the shipping paper shall be: (A) In a holder, which is mounted to the inside of the door on the driver's side of the vehicle; or (B) on the driver's seat in the vehicle."

P/N	DESCRIPTION
VDP	Vehicle Door Pouch For DOT Papers

CYLINDER VALVE GUARD and **CAP** meet DOT, OSHA, and MSHA requirements. **GT11** can be fitted and padlocked over a cylinder valve with a regulator attached. The **CCAP** can be fitted over a cylinder valve only. Measures 3⅛" x 11 tpi.

P/N	DESCRIPTION
GT11	Cylinder Valve Guard
CCAP	Cylinder Cap

CYLINDER RACK SYSTEM can be used to meet DOT 49CFR, section 177.840 requirement for transporting compressed gas cylinders. The **Series E** horizontal track is finished with a gray primer and ready to install. Each **Cylinder Belt** comes with a ratchet buckle and spring-loaded fittings.

P/N	DESCRIPTION
ETK	5' Section E-Track
CB2	2" Cylinder Belt 6" Fixed x 3' Adj
CB1	2" Cylinder Belt 23" Fixed x 6' Adj

Save-A-Load® CARGO BAR keeps your cargo in place. It features a maintenance-free pump with a push-button instant release and a pressure-limiting valve that protects the walls of the vehicle. Its pivoting feet and non-slip rubber pads enable the bar to grip any surface, even bedliners. Adjusts from 47"-75".

P/N	DESCRIPTION
PUCB	Cargo Bar

PLACARD for meeting DOT 49CFR, section 172.519 requirement of placarding when carrying more than 1000 lb aggregate gross weight of hazardous materials. Placard can display the following: Oxygen, Flammable Gas, Non-Flammable Gas, Inhalation Hazard, or blank.

P/N	DESCRIPTION
VHP1	DOT Placard



VIR100



HMSPDE w/ VDP In Use



RDEP

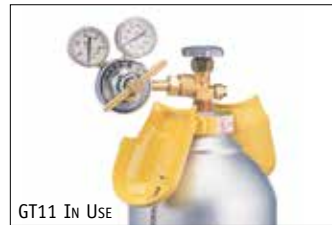

GT11 In Use



CCAP

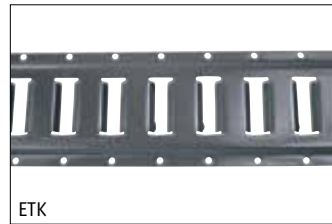

ETK



ETK, CB1 In Use



CB1



PUCB



VHP1



MDWC

To keep your light truck or van from rolling, use this **STANDARD WHEEL CHOCK**. Featuring fiber-reinforced-rubber construction, its gripping fluted design increases downward pressure, ensuring tires stay locked in place. 8.5 lb.

P/N	DESCRIPTION	L X H X W
MDWC	Standard Chock	10" x 8" x 6"

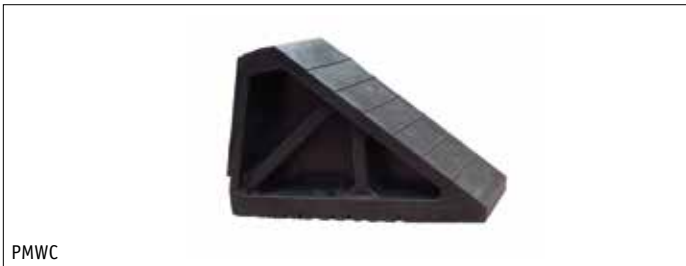

PMWC

For larger tire diameters, use this molded **PREMIUM WHEEL CHOCK**. Its weight-saving, wedge-shaped design provides additional holding power. 7.3 lb.

P/N	DESCRIPTION	L X H X W
PMWC	Premium Chock	12" x 6 ¹³ / ₁₆ " x 4 ¹ / ₂ "

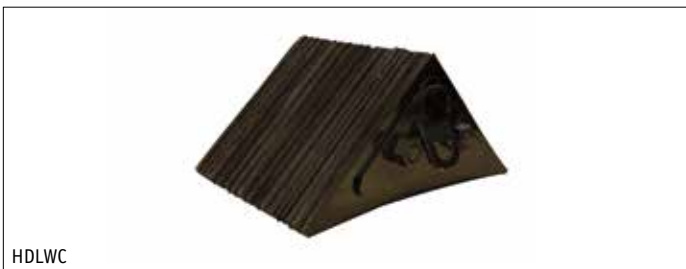

HDLWC

For maximum holding power, choose the **HEAVY-DUTY WHEEL CHOCK**. Made of reinforced rubber sheets that are laminated between thick steel end plates, it features a curved surface that really grips the road. A welded-on steel eye protects against loss. 11.5 lb.

P/N	DESCRIPTION	L X H X W
HDLWC	Heavy-Duty Chock	11" x 6" x 8"

NOTE: Please review and follow proper wheel chock procedures whenever using wheel chocks. Test chocks to ensure they meet your requirements. See product listing on BrooksEquipment.com for complete warning and use information.



TC18R, TC18



TCH In Use

TRAFFIC SAFETY

Our **TRAFFIC CONES** are molded of polyvinyl chloride with the cone and base being one continuous layer to prevent separation. Cones are designed for easy stacking (without sticking) and return to shape when crushed. Dayglow Orange.

P/N	DESCRIPTION
TC12	12" Cone
TC18	18" Cone
TC18R	18" Cone w/ 6" Reflective Stripe
TC28	28" Cone
TC2864	28" Cone w/ 4" & 6" Reflective Stripes
TC36	36" Cone
TCH	Traffic Cone Holder For 18" & 28" Cones



TD42

Made to stand up to passing traffic, this **TRAFFIC DELINEATOR'S** two-piece design and heavy base keep it upright in the windiest of conditions. It comes with a reflective band and T-top to hold a standard barricade light or barricade tape. 13 lb. Fluorescent Orange.

P/N	DESCRIPTION
TD42	45" Delineator (Post & Base)

COLLAPSIBLE CONES are extraordinarily bright and easy to see, thanks to their hi-vis orange material, reflective bands, and battery-powered LED light inside the cone. The light features two modes—Flashing or Steady Burn. Cones collapse flat for easy storage and include two AAA alkaline batteries for LED light.

P/N	DESCRIPTION
CTC418TS	18" Collapsible Cone w/o Feet, Pkg/4
CTC428TS	28" Collapsible Cone w/ Feet, Pkg/4
CTC528TS	28" Collapsible Cone w/ Feet, Pkg/5
TFAAAB	AAA Alkaline Batteries, Pkg/4



CTC428TS

REFLECTOR TRIANGLE KIT, as required by FMCSR, section 393.95, consists of three triangles in a heavy-duty plastic storage case. 15 lb.

P/N	DESCRIPTION
3TKD	3-Piece Triangle Kit



3TKD

These handy **MEASURING WHEELS** accurately track inches and feet and are fully automatic. Each wheel comes with a mechanical counter, push-button zero reset, impact-resistant wheels, and a telescoping aluminum handle. The **Single Wheel** model reads up to 10,000' and measures 16³/₄" (collapsed) and 38¹/₄" (extended). The **Double Wheel** model reads up to 10,000', and measures 21³/₄" (collapsed) and 38" (extended), and its pistol grip design reduces wrist fatigue.

P/N	DESCRIPTION
DMWC	Single Measuring Wheel
DMWM	Double Measuring Wheel



DMWC

DMWM

This 79-piece deluxe **ROADSIDE EMERGENCY KIT** comes complete with emergency signaling, lighting, survival, automotive, personal, and first aid products. Contents subject to change without notice.

P/N	DESCRIPTION
8901TS*	Deluxe Roadside Kit

*UNAVAILABLE IN AK, HI, PR, OR CATALINA

ROADSIDE KIT CONTENTS

- | | |
|---------------------------------|---------------------------|
| (3) 20 Minute Road Flares | (1) Shop Cloth |
| (1) Folding Reflective Triangle | (35) Bandages |
| (1) Flashlight | (1) Large Wound Pad |
| (2) "D" Batteries | (2) First Aid Cream Packs |
| (1) 6" Green Lightstick | (6) Alcohol Wipes |
| (1) Orange Vest | (4) Towelettes |
| (1) Rain Poncho | (6) Antiseptic Towelettes |
| (1) Thermal Blanket | (4) Sting Wipes |
| (1) Multi-Tool | (1) Cold Pack |
| (1) Jumper Cables | (2) Latex Gloves |



8901TS

Lightweight and reusable, this **SAFETY FENCE** is made of polyethylene and is UV stabilized to resist fading. 8.5 lb. Measures 4' x 100'. Hi-Vis Orange.

P/N	DESCRIPTION
SF4100	Safety Fence

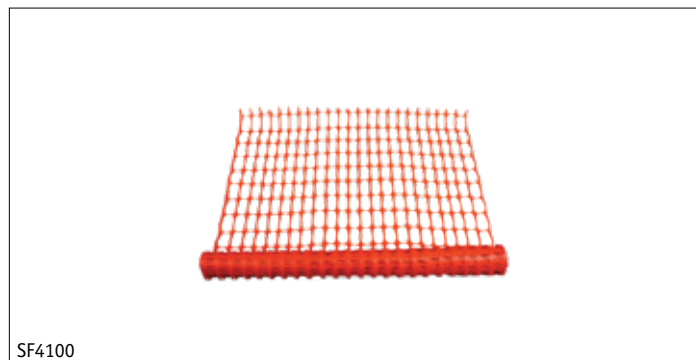

SF4100



RLB

Highly luminous, these **LIGHT BATONS** feature 25 LEDs that flash approximately 150 times per minute. They come with a three-stage switch for Off, Flashing, or Steady light as well as a wrist strap. Requires two D-cell batteries (not included). Batons measure 21¹/₂" x 1³/₄".

P/N	DESCRIPTION
RLB	Light Baton, Red
BLB	Light Baton, Blue
GLB	Light Baton, Green
TFDB	D Alkaline Batteries, Pkg/2



TF1824



FTFC IN USE

PVWC FLAGS come with 3/4" Dia wooden dowel handles. Fluorescent Orange.

P/N	DESCRIPTION
TF1824	18" x 18" Traffic Flag w/ 24" Dowel
TF1830	18" x 18" Traffic Flag w/ 30" Dowel
TF2436	24" x 24" Traffic Flag w/ 36" Dowel

Keep flares protected and handy with a **SAFETY FLARE CONTAINER**. The red plastic container is water resistant and virtually indestructible. Holds up to a dozen 30-minute flares.

P/N	DESCRIPTION
FTFC	Flare Container (Only)



SF3036

These **STANDARD SAFETY FLARES** can be used day or night in thick fog, snow, or rain. Flares burn bright red. Sold in package quantities only.

NOTE: Additional hazardous material shipping charges apply to these products.



SF3036S

P/N	DESCRIPTION	PKG QTY
SF2072	20-Minute Flare, Non-Spiked	72
SF3036	30-Minute Flare, Non-Spiked	36
SF2072S	20-Minute Flare, Spiked	72
SF3036S	30-Minute Flare, Spiked	36
SF3036WS	30-Minute Flare w/ Wire Stand	36



MLSH IN USE



LIGHTSTICKS

Snaplight® 6" LIGHTSTICKS don't produce heat or flame, only bright hazard-free light with a single snap. Illumination is created through a non-flammable chemical reaction. They are weatherproof and maintenance-free with 360° of illumination, up to one mile. Magnetic holder (sold separately) holds 6" lightsticks.

P/N	DESCRIPTION
LSBL8	8-Hour Lightstick, Blue
LSWH8	8-Hour Lightstick, White
LSY12	12-Hour Lightstick, Yellow
LSG12	12-Hour Lightstick, Green
LSR12	12-Hour Lightstick, Red
LSOR12	12-Hour Lightstick, Orange
MLSH	Magnetic Lightstick Holder

Ozone safe, this **SIGNAL AIR HORN** meets USCG requirements for boats up to 65'. 8 oz.

P/N	DESCRIPTION
509TS	Signal Horn



509TS



FH8512

FORM HOLDER secures and organizes loose forms, invoices, work orders, etc; and its swivel bar clip and writing plate makes it easy to fill out paperwork. Measures 8¹/₂" x 12".

P/N	DESCRIPTION
FH8512	Form Holder

In Use photos may show items not included or available separately.

The **NOTEBOOK MOBILE DESK** is ideal for anyone who uses their vehicle as an office and needs a comfortable writing surface. It installs over any 16" steering wheel in seconds. Perfect for laptops and tablets. Measures 15¹/₄" x 13¹/₂".

P/N	DESCRIPTION
MDWG	Mobile Desk

PERSONAL SAFETY

Work Master™ LIFE VESTS are a must for the many marine-type jobs encountered in the fire safety industry. Constructed of closed-cell foam, they feature an encircling body belt with strap tunnels to reduce snag hazards and marine mesh lining for breath ability. A flotation collar and **SOLAS**-grade reflective tape are added for additional protection. USCG approved, Type III/V device.

P/N	DESCRIPTION
I222U	Life Vest, Adult Universal (30"-52" Chest)
I2220S	Life Vest, Adult Oversize (52"-62" Chest)

This **MEGAPHONE** has a superior audio system with an acoustic range of up to one mile for loud and clear messaging. It features a comfortable pistol-grip with a trigger switch for one-handed operation and comes standard with an adjustable volume control, microphone, and alarm siren. Powered by eight C-cell alkaline batteries (not included). Measures 14¹/₂" x 9".

P/N	DESCRIPTION
MPHONES	Megaphone w/ Siren
TFCB	C Alkaline Batteries, Pkg/2

Designed for convenient carry, this **SELF-DEFENSE SPRAY** goes in a pocket or purse or on a key ring. When needed, it fires a powerful cone-shaped stream of **3-in-1® Formula** with highly effective results. It comes standard with a snap-close holster and key ring for easy carry.

NOTE: See product listing on BrooksEquipment.com for shipping prohibitions.

P/N	DESCRIPTION
SDS	Self-Defense Spray, 0.38 oz Aerosol

PLASTIC SAFETY WHISTLE with attached lanyard.

P/N	DESCRIPTION
KRSW1	Safety Whistle

The **ProFlex® 400 UNIVERSAL WRIST WRAP** supports your wrists and prevents strains and pains with its durable woven elastic construction. Its hook-and-loop closure adjusts to an exact tension and fit. Ambidextrous. One size. Black.

P/N	DESCRIPTION
WRST	Wrist Wrap

ProFlex® BACK SUPPORTS feature adjustable/detachable suspenders, non-conductive polypropylene stays, and 7¹/₂" elastic bodies. Their design helps remind the wearer to lift properly, while their 5" single-layer elastic cinch straps offer positive tension. Black.

P/N	DESCRIPTION	SIZE
BSBS	Back Support	SM
BSBM	Back Support	MD
BSBL	Back Support	LG
BSBXL	Back Support	XL

In Use photos may show items not included or available separately.



MDWG In Use



I222U



MPHONES



SDS In Use

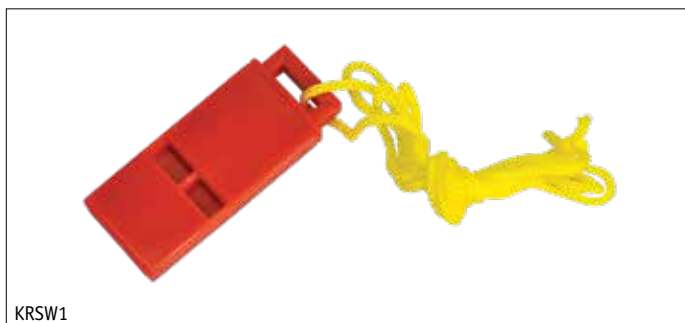

KRSW1



WRST In Use



BSBS

Available In 2 & 3 Story Models

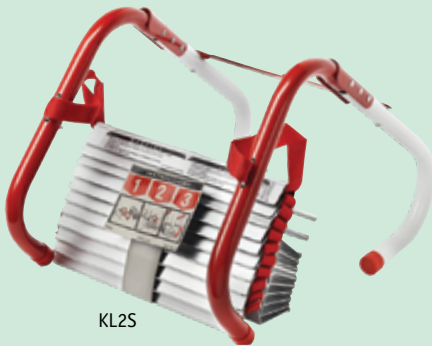

KL25

Portable emergency **ESCAPE LADDERS** store easily for quick access in an emergency. No assembly required—just hang the brackets over the window sill, toss out the ladder, and climb down. Features anti-slip rungs and five-year warranty. Tested to 1000 lb. **NOTE:** One-time use only.

P/N	DESCRIPTION
KL25	13' Escape Ladder
KL35	25' Escape Ladder



FRQS



FRG

LADDERS, BLANKETS, AND RETARDANT

Inspecta-Shield™ FIRE RETARDANT is a Class A fire retardant for fibers, lumber, and wood materials. Pre-mixed, easy to apply, non-toxic, non-allergenic, colorless, odorless (when dried), durable, and UV stable. Works by slowing horizontal and vertical flame spread. Does not prevent charring, but treated items will not support ignition. Directions are included. Not recommended for outdoor use. UL classified.

NOTE: UL Letter of Certification can be granted up to two years after the date of manufacture.

P/N	DESCRIPTION
FRQS	Fire Retardant, 1 qt Spray
FRG	Fire Retardant, 1 gal
FRP5	Fire Retardant, 5 gal



64FB FRONT VIEW



64FB BACK VIEW

FIBERGLASS BLANKET comes in a low-profile plastic **CABINET**, complete with instruction labels and pull straps for quick withdrawal. Cabinet measures 14³/₄"H x 6¹/₄"W x 1¹/₂"D. Blanket measures 72" x 48".

NOTE: One-time use only.

P/N	DESCRIPTION
64FB	Fire Blanket & Cabinet

WOOL BLANKET measures 80" x 62" and is treated for fire retardancy. **VINYL BAG** measures 17"L x 12"W x 4"D. Features four mounting holes with brass grommets and hook-and-loop closure.

P/N	DESCRIPTION
FBB1	Fire Blanket Bag (Only)
FBR2	Fire Blanket For FBB1

Roller-mounted **WOOL BLANKET** with arm loop measures 80" x 62" and is treated for fire retardancy. **ALL-STEEL CABINET** with red enamel finish measures 68"H x 6¹/₂"W x 4"D.

P/N	DESCRIPTION
1FB	Fire Blanket Roll-Out Cabinet (Only)
FBR1	Fire Blanket For 1FB



FBB1 w/ FBR2



1FB

ABS CABINET with **WOOL BLANKET** features a brass lock and screen-printed labeling. Cabinet is made of high-impact, flame-resistant ABS. Blankets are 80" x 62" and treated for fire retardancy. No dangerous glass to break, rustproof, and theft-resistant. Red tub with clear cover.

P/N	DESCRIPTION
M2FBC	Fire Blanket Cabinet w/ Blanket
M2RFC	Fire Blanket Tub (Only)
FBR2	Fire Blanket
M2C	Clear Replacement Cover
M12L	Brass Padlock, Keyed Alike

WOOL BLANKET is treated for fire retardancy and measures 80" x 62". **ALL-STEEL CABINET** features a tailgate-style door and red enamel finish. Cabinet measures 10"H x 16"W x 7⁵/₈"D.

P/N	DESCRIPTION
2FB	Drop-Down Fire Blanket Cabinet (Only)
FBR2	Fire Blanket For 2FB

EMERGENCY PREPAREDNESS

This **EMERGENCY PREPAREDNESS 1-DAY BACKPACK** contains critical supplies for emergency situations, like severe weather and power outages. It all comes in a lightweight backpack with padded shoulder straps for easy transport, and it is big enough to hold additional items. A glow-in-the-dark tag makes it easy to find too. Assembly of products is based on guidelines provided by the American Red Cross and Homeland Security. 12¹/₂"H x 4¹/₂"W x 17¹/₂"D. Orange.

1-DAY PACK CONTENTS

- | | |
|-------------------------------------|----------------------------|
| (15) 3/4" x 3" Adhesive Bandages | (1) Rain Poncho |
| (5) 3/8" x 1 1/2" Adhesive Bandages | (1) Emergency Blanket |
| (1) Antibiotic Ointment Packet | (1) Light Stick |
| (3) Antiseptic Wipes | (1) Whistle |
| (3) Alcohol Prep Pads | (1) Dust Mask |
| (2) Acetaminophen Tablets | (1) Pair Vinyl Gloves |
| (2) Ibuprofen Tablets | (2) Hand Sanitizer Packets |
| (2) Antacid Tablets | (1) First Aid Guide |

P/N	DESCRIPTION
→ FA90123	Emergency 1-Day Backpack

This **EMERGENCY PREPAREDNESS 3-DAY BACKPACK** contains critical supplies for emergency situations, like severe weather and power outages. It all comes in a lightweight backpack with padded shoulder straps for easy transport, and it is big enough to hold additional items. A glow-in-the-dark tag makes it easy to find too. Assembly of products is based on guidelines provided by FEMA and the American Red Cross. 17¹/₂"H x 12¹/₂"W x 4¹/₂"D. Orange.

3-DAY PACK CONTENTS

- | | |
|-----------------|-----------------------|
| Food | (1) Rain Poncho |
| Water | (1) Emergency Blanket |
| Alert Whistle | (2) Hand Warmers |
| (1) Light Stick | (1) Mask |
| (1) Flashlight | (2) Cotton Gloves |

P/N	DESCRIPTION
→ FA90001	Emergency 3-Day Backpack



M2FBC



2FB w/ FBR2



→ NEW

FA90123



→ NEW

FA90001



DALHAT



GBPHAT



NOSHAT



PITHAT



USAHH



CAMOHH



YHH1



WHH2



OHH2



WHH4



HHA102 w/ A8150 In Use

HEAD PROTECTION

Football fans across the country can have on-the-job protection while showing loyalty to their favorite team. Officially-licensed **NFL® LOGO V-GARD® HELMETS** are fun to wear, and each one meets or exceeds the requirements for Type 1 helmets, per ANSI Z89.1 (Class E) and CSA Z94.1 (Class E). Every cap features a **1-Touch®** suspension, guaranteeing easy adjustment with superior comfort. Available in all 32 NFL teams.

P/N	DESCRIPTION	P/N	DESCRIPTION
RZHAT	Arizona Cardinals	LACHAT	Los Angeles Chargers
ATLHAT	Atlanta Falcons	LARHAT	Los Angeles Rams
BALHAT	Baltimore Ravens	MIAHAT	Miami Dolphins
BUFHAT	Buffalo Bills	MINHAT	Minnesota Vikings
CARHAT	Carolina Panthers	NEPHAT	New England Patriots
CHIHAT	Chicago Bears	NOSHAT	New Orleans Saints
CINHAT	Cincinnati Bengals	NYGHAT	New York Giants
CLVHAT	Cleveland Browns	NYJHAT	New York Jets
DALHAT	Dallas Cowboys	OAKHAT	Oakland Raiders
DENHAT	Denver Broncos	PHLHAT	Philadelphia Eagles
DETHAT	Detroit Lions	PITHAT	Pittsburgh Steelers
GBPHAT	Green Bay Packers	SF49HAT	San Francisco 49ers
HOUHAT	Houston Texans	SEAHAT	Seattle Seahawks
INDHAT	Indianapolis Colts	TBBHAT	Tampa Bay Buccaneers
JACHAT	Jacksonville Jaguars	TENHAT	Tennessee Titans
KCCHAT	Kansas City Chiefs	WSHHAT	Washington Redskins

Freedom Series™ CAPS show your patriotism and protect your head at the same time. **Fas-Trac® III** suspensions ensure your helmets are lightweight, durable, and comfortable. Accessory slots accept all **V-Gard®** accessories.

P/N	DESCRIPTION
USAHH	Cap, Stars & Stripes
CAMOHH	Cap, Camo

HARD HATS are made of high-density polyethylene. The ratchet suspension models won't fall off, even when working upside down. The **HH1**, **HH2**, and **HH4** models meet ANSI Z89.1, Type I, Class E and CSA Z94.1, while the **HH3** meets Type II, Class E requirements. The **HH3** also comes with a forehead comfort band and crown pad for comfort. Hard hats will accept most visors and hearing protection devices listed elsewhere (except **HH4**).

P/N	DESCRIPTION
YHH1	Hard Hat, Yellow
WHH1	Hard Hat, White
YHH2	Hard Hat w/ Ratchet, Yellow
WHH2	Hard Hat w/ Ratchet, White
OHH2	Hard Hat w/ Ratchet, Orange
WHH3	Hard Hat w/ Ratchet (Type II), White
WHH4	Full-Brim Hard Hat w/ Ratchet, White

HARD HAT ACCESSORIES include a face shield bracket made of tough aluminum. The **A8150** is made of 0.040"-thick PETG, while the **A8154** is formed from 0.040"-thick polycarbonate. Both are recommended for general eye and face protection and work with hard hat-mounted earmuffs. Shields measure 8" x 15½". Clear.

P/N	DESCRIPTION
HHA102	Face Shield Bracket
A8150	PETG Face Shield
A8154	Polycarbonate Face Shield

In Use photos may show items not included or available separately.

Secure your hard hats with **Squids® COILED HARD HAT LANYARDS**. The **Buckle** style attaches to fall protection, while the **Clamp** version attaches to just about anything. Both feature a coil design with a 2 lb max capacity. Hi-Vis Lime.

P/N	DESCRIPTION
HHA19157	Lanyard w/ Buckle Attachment
HHA19159	Lanyard w/ Clamp Attachment



HHA19157 In Use

EYE PROTECTION

BearKat® SAFETY GLASSES get their tenacity from flexible temples and their hold from nonslip rubber head grips. Add to that an unobstructed view (courtesy of scratch-resistant, wraparound lenses) really cool colors, and very affordable prices. Meets ANSI Z87.1+ requirements. 99.9% UV protection.

P/N	DESCRIPTION
BK110AFC	Safety Glasses, Clear Frame/Anti-Fog Lens
BK110C	Safety Glasses, Clear Frame/Lens
BK112AFC	Safety Glasses, Gray Frame/Anti-Fog Lens
BK112C	Safety Glasses, Gray Frame/Lens
BK113C	Safety Glasses, Light Blue Frame/Lens
BK114C	Safety Glasses, Amber Frame/Lens
BK117C	Safety Glasses, Silver Mirror Frame/Lens
BK118C	Safety Glasses, Blue Mirror Frame/Lens
BK119C	Safety Glasses, Indoor/Outdoor Clear Mirror Frame/Lens



BK114C

BK118C

BearKat® MAGNIFIER SAFETY GLASSES provide a lightweight, snug fit with wraparound lenses for a wide, unobstructed peripheral view. Flexible temples and nonslip rubber head grips keep them secure, while scratch-resistant coatings keep lenses clearer longer. Meets ANSI Z87.1+ requirements. 99.9% UV protection.

P/N	DESCRIPTION
BKH10C	Magnifier Safety Glasses, Clear Frame/Lens, 1.0 Diopter
BKH10GC	Magnifier Safety Glasses, Gray Frame/Lens, 1.0 Diopter
BKH15C	Magnifier Safety Glasses, Clear Frame/Lens, 1.5 Diopter
BKH15GC	Magnifier Safety Glasses, Gray Frame/Lens, 1.5 Diopter
BKH20C	Magnifier Safety Glasses, Clear Frame/Lens, 2.0 Diopter
BKH20GC	Magnifier Safety Glasses, Gray Frame/Lens, 2.0 Diopter
BKH25C	Magnifier Safety Glasses, Clear Frame/Lens, 2.5 Diopter
BKH25GC	Magnifier Safety Glasses, Gray Frame/Lens, 2.5 Diopter



BKH10C

Storm® SAFETY GLASSES offer extreme comfort, thanks to ratchet-action temples and nonslip rubber head grips. Their wraparound lenses are constructed of lightweight, scratch-resistant polycarbonate for extra toughness. Meets ANSI Z87.1+ requirements. 99.9% UV protection. Black frame.

P/N	DESCRIPTION
EW107	Safety Glasses, Clear Anti-Fog Lens
EW108	Safety Glasses, Gray Anti-Fog Lens



BKH10GC

Tomahawk® SAFETY GLASSES feature five-position ratchet-action temples, wraparound polycarbonate lenses, and integral side shields. Frames are lightweight, adding to their comfort. Meets ANSI Z87.1+ requirements. 99.9% UV protection. Black frame.

P/N	DESCRIPTION
EW102	Safety Glasses, Clear Lens
TK112C	Safety Glasses, Gray Lens



EW108



EW102



NEMSAF

Nemesis™ SAFETY GLASSES offer a sleek, sporty style that is designed for safety and comfort. Lightweight with flex temples for an effortless fit, they feature single wraparound lenses for excellent impact protection and a neck cord to keep them handy. Meets ANSI Z87.1+. 99.9% UV protection. Black frame.

P/N	DESCRIPTION
NEMBM	Safety Glasses, Blue Mirror Lens
NEMC	Safety Glasses, Clear Lens
NEMIO	Safety Glasses, Indoor/Outdoor Clear Lens
NEMSM	Safety Glasses, Smoke Mirror Lens
NEMCAF	Safety Glasses, Clear Anti-Fog Lens
NEMSAF	Safety Glasses, Smoke Mirror Anti-Fog Lens



→ NEW

EW4165

Uvex® Acadia™ SAFETY GLASSES feature a $\frac{3}{4}$ frame in a lightweight, sporty design that offers lasting comfort and protection. These versatile wraparound glasses can be worn indoors or out and come standard with **Uvextreme Plus®** anti-fog coating, so their lenses stay clear up to ten-times longer with two-times more scratch resistance. Other features include integrated hinges; a soft ribbed nosepiece; and sculpted, padded temples. Meets ANSI Z87.1. 99.9% UV protection. Black frame, blue mirror lens.

P/N	DESCRIPTION
→ EW4165	Safety Glasses



EW101

With **Tacoma® SAFETY GLASSES**, get low-cost protection without giving up quality, comfort, or durability. Made of strong, lightweight polycarbonate with a one-piece wraparound lens for a wider field of vision and maximum protection. Fits over most personal eyewear. Meets ANSI Z87.1+. 99.9% UV protection. Black temples, clear lens.

P/N	DESCRIPTION
EW101	Safety Glasses



OG112AFC

LAW® OTG (Over The Glass) SAFETY GLASSES feature durable dielectric nylon frames with five-position ratcheting temples. Other standard features include scratch-resistant coatings and nonslip temple inserts. Meets ANSI Z87.1+. 99.9% UV protection. Silver temples with anti-fog lenses.

P/N	DESCRIPTION
OG110AFC	Safety Glasses, Clear
OG112AFC	Safety Glasses, Gray



EW201

These economical **SAFETY GOGGLES** feature a soft, comfortable perforated frame; direct ventilation; and a wide one-piece polycarbonate lens. Meets ANSI Z87.1+. 99.9% UV protection. Clear frame, clear lens.

P/N	DESCRIPTION
EW201	Economy Goggles



EW241

Premium **Verdict® SAFETY GOGGLES** can be worn with most half-mask respirators while fitting over most prescription eyeglasses. Goggles feature a PVC frame, indirect ventilation, and adjustable elastic strap. Meets ANSI Z87.1+. 99.9% UV protection. Gray frame, clear anti-fog lens.

P/N	DESCRIPTION
EW241	Safety Goggles

SightGuard® GOGGLES are an excellent choice for splash and impact protection. Vented to reduce fogging. Meets ANSI Z87.1+. 99.9% UV protection. Clear frame, clear anti-fog lens.

P/N	DESCRIPTION
10106270MSA	Safety Goggles

The **Skullerz® EYEWEAR LANYARD** features a slip-fit style that accommodates most eyewear frames. Made of 3 mm nylon rope with a single breakaway safety design. Black.

P/N	DESCRIPTION
19342EG	Eyewear Lanyard

This **LENS CLEANING STATION** is perfect for the care and maintenance of safety eyewear. Containing two boxes of 300 tissues and one 8 oz bottle of anti-fog/anti-static cleaning spray, this station extends the life of protective eyewear by keeping it clean.

P/N	DESCRIPTION
LCS1	Lens Cleaning Station

The **PureFlow 1000 EYEWASH STATION** delivers saline solution that is purified, contaminant-free, and physiologically correct from a sealed integrated delivery module. The cartridge has a 24-month shelf life (from date of manufacture), and the unit has a 15-minute flush time. Must purchase fluid cartridges separately. Meets ANSI Z358.1 15-minute flushing requirement.

P/N	DESCRIPTION
1000ES	Eyewash 1000 Station (Only)
1000FC	Eyewash 1000 Fluid Cartridges, Pkg/2
RP176A	"Emergency Eye Wash" ANSI Z535 Sign, Plastic, 7" x 10"
PTD176	"Emergency Eye Wash" 3-D Sign, Plastic, 18" x 10"

Eyesaline® EYEWASH PRODUCTS provide immediate flushing of the eyes with sterile saline solution. **Wall Stations** hold bottles in place for quick, easy access in emergencies, while **Bottles** feature tamperproof twist-off tabs that cannot be replaced after removing. Three-year shelf life.

P/N	DESCRIPTION
460ES	Single 16 oz Eyesaline Wall Station
461ES	Single 32 oz Eyesaline Wall Station
462ES	Double 32 oz Eyesaline Wall Station
454EB	Replacement 16 oz Eyesaline Bottle
455EB	Replacement 32 oz Eyesaline Bottle

Brooks' EMERGENCY SHOWER & EYEWASH INSPECTION TAGS help meet ANSI Z358.1 requirements, making them a perfect solution to emergency shower and eyewash equipment inspection recording. Tags feature non-coated 13-pt stock with reinforced eyelets. 3" x 5 3/4". White with green print. Pkg/100.

P/N	DESCRIPTION
EWTAG	Shower/Eyewash Inspection Tags





38030MWLMG In Use



39418MG

WELDING APPAREL

From full-leather jackets to a leather bib apron and sleeves, our **LEATHER WELDING APPAREL** fits your protective apparel needs perfectly. Jackets and apron come with pockets and are riveted at all major stress points, while sleeves feature full coverage from above the elbow down to the wrist. Other features include anodized button snaps to prevent arc flashback. Gray.

P/N	DESCRIPTION
38030MWLMG	Leather Welding Jacket, 30", Large
38030MWXLMG	Leather Welding Jacket, 30", X-Large
38142MWMG	Leather Welding Bib Apron, 24"x 42"
38418MWMG	Leather Welding Sleeves, 18" (Pair)



MG4950L

Flame-resistant **COTTON WELDING SLEEVES** feature 9 oz treated cotton fabric with 2 1/4" heavy-duty elastic bands at the tops and wrists for a secure, comfortable fit. Green. Sold in pairs.

P/N	DESCRIPTION
39418MG	Cotton Welding Sleeves, 18"
39423MG	Cotton Welding Sleeves, 23"



MG4500

Mustang™ WELDING GLOVES feature all-leather construction with grain cow leather palms and backs plus split leather 4 1/2" gauntlet cuffs. Sewn with **Kevlar®** thread for extra toughness. Cream/Russet. Sold in pairs.

P/N	DESCRIPTION
MG4950L	Welding Gloves, Large
MG4950XL	Welding Gloves, X-Large

These economy **LEATHER WELDING GLOVES** are generously cut in a gunn pattern with winged thumbs and welts in the high-stress areas. The **MG4300B** features full-fleece linings that are sewn in at the fingertips. The **MG4500** features 4 mil foam and red jersey sock linings. One-piece leather backs add toughness. X-Large. Sold in pairs.

P/N	DESCRIPTION
MG4300B	Economy Welding Gloves, Russet
MG4500	Economy Welding Gloves w/ Double Reinforced Palms/Thumbs & Kevlar Thread, Blue



38505MWMG In Use

LEATHER SHOE PROTECTORS go easily over tops of shoes or boots and use two straps around the ankle and one under the sole for a snug fit. One size. Gray.

P/N	DESCRIPTION
38505MWMG	Leather Shoe Protectors

100% Flame-Resistant

Cotton twill **Max Comfort® FR CONTRACTOR COVERALLS** come with heavy-duty, two-way **YKK®** brass breakaway zippers. The zippers are also taped with **Nomex** and include protective storm flaps and snap closures. There are two chest, two front hip, and two back patch pockets as well as adjustable snap closures at cuffs and legs. NFPA 2112 UL Certified, NFPA 70E HRC=2 ATPV 9.3 cal/cm², and meet ASTM F1506 requirements for Electric Arc Protection. Navy.

P/N	DESCRIPTION	SIZE
CC1N44	FR Coveralls	44
CC1N46	FR Coveralls	46
CC1N46T	FR Coveralls	46 Tall
CC1N48	FR Coveralls	48
CC1N48T	FR Coveralls	48 Tall
CC1N50	FR Coveralls	50
CC1N50T	FR Coveralls	50 Tall
CC1N52	FR Coveralls	52
CC1N52T	FR Coveralls	52 Tall
CC1N54	FR Coveralls	54
CC1N54T	FR Coveralls	54 Tall
CC1N56	FR Coveralls	56
CC1N56T	FR Coveralls	56 Tall



CC1N44

Featuring 14.75 oz flame-resistant 100% cotton denim, these heavyweight **Max Comfort® FR JEANS** have reinforced belt loops, a coin pocket, and two large back patch pockets. NFPA 2112 UL Certified, NFPA 70E HRC=2, ATPV 20 cal/cm², and meet ASTM F1506 Electric Arc Protection requirements. Indigo Blue.

P/N	DESCRIPTION	SIZE
P1D3230	FR Jeans	32 x 30
P1D3232	FR Jeans	32 x 32
P1D3234	FR Jeans	32 x 34
P1D3236	FR Jeans	32 x 36
P1D3430	FR Jeans	34 x 30
P1D3432	FR Jeans	34 x 32
P1D3434	FR Jeans	34 x 34
P1D3630	FR Jeans	36 x 30
P1D3632	FR Jeans	36 x 32
P1D3634	FR Jeans	36 x 34
P1D3830	FR Jeans	38 x 30
P1D3832	FR Jeans	38 x 32
P1D3834	FR Jeans	38 x 34
P1D3836	FR Jeans	38 x 36
P1D4030	FR Jeans	40 x 30
P1D4032	FR Jeans	40 x 32
P1D4034	FR Jeans	40 x 34
P1D4230	FR Jeans	42 x 30
P1D4232	FR Jeans	42 x 32
P1D4234	FR Jeans	42 x 34



P1D3430

Max Comfort® FR SHIRTS are using 6.5 oz flame-resistant cotton/nylon-blend fabric. They are stitched with **Nomex®** flame-resistant thread and come with two flap chest pockets and adjustable cuffs with two cuff buttons each. NFPA 2112 UL Certified, NFPA 70E HRC=2, ATPV 9.5 cal/cm², and meet ASTM F1506 Electric Arc Protection requirements. Tan.

P/N	DESCRIPTION	SIZE
S1TM	FR Shirt	MD
S1TL	FR Shirt	LG
S1TXL	FR Shirt	XL
S1TX2	FR Shirt	2XL



S1TX2



EP07



EPQD30

HEARING PROTECTION

Easy-to-use **EAR PLUGS** come in a dispenser-style box and are moisture resistant. They form a constant and effective Noise Reduction Rating when used as directed. Boxed in individually wrapped pairs.

P/N	DESCRIPTION
EP07	Disposable Foam Ear Plugs, Uncorded (NRR 30), Pkg/200
EPQD30	Reusable Ear Plugs, Corded (NRR 26), Pkg/100



EMTHHB



EMTHCM In Use

Headband and hard hat-mounted **Thunder® EARMUFFS**, for basic hearing protection, are lightweight and durable with soft-sealing cushions and a unique cup design for good sound level reduction. **Headband** earmuffs have a Noise Reduction Rating of 26 dB, and **Hard Hat-Mounted** earmuffs have a 25 dB rating when used as directed. Mounted earmuffs are compatible with hard hats on page 68.

P/N	DESCRIPTION
EMTHHB	Headband Earmuffs
EMTHCM	Hard Hat-Mounted Earmuffs



RP9500



RP1730

RESPIRATORY PROTECTION

Disposable **COMFORT MASKS** offer relief from nuisance and non-toxic dusts, powders, and pollen. They are lightweight with an adjustable metal forming strip over the nose for comfort. Pkg/50.
NOTE: Does not provide NIOSH-approved respiratory protection.

P/N	DESCRIPTION
RP9500	Nuisance Dust Masks



RP9200

Disposable **PARTICULATE RESPIRATORS** come with soft, smooth inner linings and nose cushions for increased comfort. Their custom shapes, nose pieces, and head straps offer a superior fit, while collapse-resistant, double-shell construction extends their life. NIOSH certified respirators have a 95% efficiency level. Pkg/20.

P/N	DESCRIPTION
RP1730	N95 Particulate Respirators

DUAL CARTRIDGE HALF-MASK RESPIRATORS

feature soft non-allergenic material that seals smoothly around the face and shape retainer inserts to hold their shape. Their cradle suspensions and adjustable head straps offer a perfect fit, while cartridges and filters keep a low swept-back profile that are out of the way of glasses or goggles. Hygiene guards keep them clean when they are not in use. Includes a reusable storage bag to meet OSHA storage requirements. Mask and cartridges are NIOSH approved.
NOTE: Consult chemical SDS for proper cartridge use.

P/N	DESCRIPTION
RP9200	Half-Mask Respirator, Medium
RP9300	Half-Mask Respirator, Large
RPF8	Filter Pad Retainers, Pkg/2
RPG01	Organic Vapor Cartridges, Pkg/2
RPG03	Organic Vapor/Acid Gas Cartridges, Chlorine, Hydrogen Chloride, Sulfur Dioxide, Pkg/2
RP95N	P95 Filter Pads, Pkg/10



RPG01



RP95N

Optimal Hand Protection – Wet or Dry!

NITRILE COATED DORSAL PROTECTION GLOVES

come with latex rubber pads to protect the back of the hands. They are made from 100% nylon with a textured palm foam nitrile coating for excellent grip in wet or dry conditions. Black/Hi-Vis Yellow. Sold in pairs.

P/N	DESCRIPTION	SIZE
YMGS	Nitrile Dorsal Gloves	SM
YMGM	Nitrile Dorsal Gloves	MD
YMGL	Nitrile Dorsal Gloves	LG
YMGXL	Nitrile Dorsal Gloves	XL
YMG2XL	Nitrile Dorsal Gloves	2XL
YMG3XL	Nitrile Dorsal Gloves	3XL



YMGL

HAND PROTECTION

WORK GLOVES offer a perfect fit for all of your hand protection needs. Heavy duty and rugged, these gloves are ideal for a wide variety of jobs. Sold in pairs.

P/N	DESCRIPTION	SIZE
8808LMG	8 oz Cotton Canvas Dotted Work Gloves, Natural/Black	LG
9688MMG	10 ga Cotton/Poly Flex Tuff Gloves w/ Latex Palms, Gray	MD
9688LMG	10 ga Cotton/Poly Flex Tuff Gloves w/ Latex Palms, Gray	LG
9688XLMG	10 ga Cotton/Poly Flex Tuff Gloves w/ Latex Palms, Gray	XL
3130MMG	Split-Leather Drivers w/ Keystone Thumbs, Brown	MD
3130LMG	Split-Leather Drivers w/ Keystone Thumbs, Brown	LG
3130XLMG	Split-Leather Drivers w/ Keystone Thumbs, Brown	XL
12010LMG	Leather Work Gloves, Gunn Pattern w/ Rubberized Safety Cuffs, Gray/Striped	LG
12010XLMG	Leather Work Gloves, Gunn Pattern w/ Rubberized Safety Cuffs, Gray/Striped	XL

Economy weight **KNIT GLOVES** offer a good grip and abrasion resistance, thanks to 60/40 cotton/poly construction with hemmed edges. Large. Natural. Sold by the dozen.

P/N	DESCRIPTION	SIZE
9668LMG	7 ga Knit Gloves	LG

CUT-RESISTANT GLOVES feature 13 ga liners that resist cuts and an advanced foam nitrile coating for excellent grip in light oil and dry environments. ANSI Cut 3 and CE EN388 4543. Gray/Black. Sold by the dozen.

P/N	DESCRIPTION	SIZE
GCR3FNS	Cut-Resistant Gloves	SM
GCR3FNM	Cut-Resistant Gloves	MD
GCR3FNL	Cut-Resistant Gloves	LG
GCR3FNXL	Cut-Resistant Gloves	XL



12010LMG



9668LMG



GCR3FNL



→ NEW

9673LMG

Ideal for jobs requiring low-lint protection, these **FOAM KNIT GLOVES** come standard with foam nitrile-coated palms and fingers as well as seamless 13 ga nylon shells. They also offer excellent grip with dexterity. Black/Gray. Sold by the dozen.

P/N	DESCRIPTION	SIZE
→ 9673SMG	Foam Dip Gloves	SM
→ 9673MMG	Foam Dip Gloves	MD
→ 9673LMG	Foam Dip Gloves	LG
→ 9673XLMG	Foam Dip Gloves	XL



G13NPUL

POLYURETHANE PALM COATED GLOVES have 13 ga nylon knit shells. CE EN388 4131. Gray. Sold by the dozen.

P/N	DESCRIPTION	SIZE
G13NPUS	Polyurethane Coated Gloves	SM
G13NPUM	Polyurethane Coated Gloves	MD
G13NPUL	Polyurethane Coated Gloves	LG
G13NPUXL	Polyurethane Coated Gloves	XL



G10CPLL

LATEX PALM COATED GLOVES feature a blue crinkle finish on the palms. Made from 10 ga poly/cotton. CE EN388 2242. Gray/Blue. Sold by the dozen.

P/N	DESCRIPTION	SIZE
G10CPLS	Latex Coated Gloves	SM
G10CPLM	Latex Coated Gloves	MD
G10CPLL	Latex Coated Gloves	LG
G10CPLXL	Latex Coated Gloves	XL

These powder-free **DISPOSABLE NITRILE GLOVES**, from **MCR**, are perfect for people who have latex allergies. Super strong with a secure fit, they provide tactile sensitivity plus chemical protection. Textured surface (4 mil). Blue. Pkg/100.

P/N	DESCRIPTION	SIZE
NIPFT102	Disposable Nitrile Gloves	SM
NIPFT103	Disposable Nitrile Gloves	MD
NIPFT104	Disposable Nitrile Gloves	LG
NIPFT105	Disposable Nitrile Gloves	XL



NIPFT104



P104

Get dependable, quality hand protection at an affordable price with **MCR DISPOSABLE LATEX GLOVES**. They are powdered with a smooth finish, and come standard with rolled cuffs (5 mil). FDA compliant. Natural. Pkg/100.

P/N	DESCRIPTION	SIZE
P103	Disposable Latex Gloves	MD
P104	Disposable Latex Gloves	LG
P105	Disposable Latex Gloves	XL

Ready-to-install, this **Purell ES™ EVERYWHERE SYSTEM STARTER KIT** comes complete with a pre-assembled base, refill cartridge, and **Command®** strips for simple surface attachment. The refill is exposed for easy monitoring of product level and servicing.

P/N	DESCRIPTION
FA1450D8	ES Kit, 450 mL, Case/8
FA145006	ES Refill, 450 mL, Case/6 For Everywhere System Starter Kit



FA1450D8

Alcohol-based **Purell® Advanced INSTANT HAND SANITIZER** works in seconds to kill 99.99% of the most common germs that cause illness. It is specially formulated with four different skin conditioning agents to leave hands soft without a sticky residue. Can be used anywhere, since no water or towels are needed.

P/N	DESCRIPTION
HANDSAN8	Hand Sanitizer, 8 oz Pump Bottle



HANDSAN8



GJS095806

Gojo® HANDCARE/CLEANERS are specially formulated to gently remove a variety of soils and effectively cleanse hands.

P/N	DESCRIPTION
GJS095806	Orange Pumice Hand Cleaner w/ Pump Dispenser, 0.5 gal
GJW629804	Fast Wipes Multi-Purpose Towels, Bucket/130



GJW629804



GPF3LNASK

Environmentally friendly, **GrittyFoam® Extra HEAVY-DUTY HAND CLEANSER** has the perfect combination of effective cleaning ingredients (including non-abrasive bio-scrubbers). It is also silicone-free with powerful foam that scrubs away all kinds of industrial dirt and grime with less water.

P/N	DESCRIPTION
GPF3LNASK	GrittyFoam Extra, 3.25 L Refills, Case/2
GPF3LDQSK	GrittyFoam Dispenser, 3.25 L

WypAll® WIPERS provide better absorption than shop rags, thanks to **Hydroknit®** technology. Available in different thicknesses for different jobs, these disposable lightweight wipers keep workers healthier and shops cleaner. Installs anywhere with a **JUMBO ROLL DISPENSER**.

P/N	DESCRIPTION
KCW180	Brag Box Wipers, 12 ¹ / ₂ " x 16 ¹³ / ₁₆ ", White, 180 ea Replaces 25 lb of Scrap Rags
KCHDW475	Jumbo Roll Wipers, 12 ¹ / ₂ " x 13 ³ / ₈ ", Red, 475 ea Replaces 75 lb of Scrap Rags
KCHDD	Jumbo Roll Dispenser, 16 ¹³ / ₁₆ "L x 33"H x 18 ¹ / ₂ "W
KCHWM	Jumbo Roll Wall Mount Dispenser, 16 ¹³ / ₁₆ "L x 8 ¹³ / ₁₆ "H x 10 ¹³ / ₁₆ "W



KCW180



KCHWM w/
KCHDW475 In Use



KCHDD w/ KCHDW475 In Use

Ideal for your toughest tasks, **Scott® TOWELS** are strong, soft, absorbent, and work like a cloth. For a quick solution to any mess, **Rags In A Box** and **Shop Towels** are great for wiping hands, cleaning tools, and absorbing liquids, oil, and grease.

P/N	DESCRIPTION
KCRB200	Rags In A Box, 10" x 13", White, Box/200
KCST55	Shop Towels, 10 ³ / ₈ " x 11", Blue, Roll/55



KCRB200



KCST55



39836MG In Use



555L

PROTECTIVE CLOTHING AND RAINWEAR

Protect your clothing with this 36" **DENIM APRON**. Two pockets carry your essentials. One size.

P/N	DESCRIPTION
39836MG	Denim Apron

PROTECTIVE COVERALLS come with open wrists and ankles, serged seams, a front zipper, and collar.



TYBC In Use

P/N	DESCRIPTION	SIZE
555L	Coveralls, White	LG
555XL	Coveralls, White	XL
555XXL	Coveralls, White	2XL
TYBC	18" Boot Covers, Non-Skid, Gray	LG/XL
TYSC	Shoe Covers, White	Universal

→ **More PROTECTIVE COVERALLS Available - Call for Pricing.**



STB10

MCR's 15" STEEL TOE PVC BOOTS feature a heavy-duty, over-the-sock design and cleated soles with traction grips. Flexible and 100% waterproof, with polyester linings and kick-off lugs for easy on/off, they offer excellent comfort and abrasion resistance. Steel toe meets ASTM/2412 and ASTM/2413 specifications. Black.

P/N	DESCRIPTION	SIZE
STB10	15" PVC Boots	10
STB11	15" PVC Boots	11
STB12	15" PVC Boots	12
STB13	15" PVC Boots	13
STB14	15" PVC Boots	14



BYR10012RC

These over-the-shoe 17" **RUBBER SLUSH BOOTS** are cotton-lined with black cleated outsoles. Top straps and buckles provide easy-on comfort and fit. Yellow.

NOTE: Order two to three sizes larger than shoe size.

P/N	DESCRIPTION	SIZE
BYR10010RC	17" Slush Boots	10
BYR10011RC	17" Slush Boots	11
BYR10012RC	17" Slush Boots	12
BYR10013RC	17" Slush Boots	13
BYR10014RC	17" Slush Boots	14
BYR10015RC	17" Slush Boots	15
BYR10016RC	17" Slush Boots	16

The **SCHOONER II PONCHO** comes with an attached hood and side snap closures. Made of 0.35 mm PVC with a polyester fabric base for heavy-duty splash situations. Yellow.

P/N	DESCRIPTION	SIZE
2000RC	Schooner II Poncho	52" x 80"



Classic **3-PIECE RAINSUITS** include jackets with plastic snap fronts, take-up wrist snaps, detachable drawstring hoods, and patch pockets with flaps. Bib pants come standard with elastic adjustable suspenders, plastic take-up snaps at the waist and ankles, and plastic snap fly fronts. Made of 0.35 mm PVC on polyester fabric. Yellow.

P/N	DESCRIPTION	SIZE
→ RW2003M	3-Piece Rainsuit	MD
→ RW2003L	3-Piece Rainsuit	LG
→ RW2003XL	3-Piece Rainsuit	XL
→ RW2003XXL	3-Piece Rainsuit	2XL
→ RW20033XL	3-Piece Rainsuit	3XL
→ RW20034XL	3-Piece Rainsuit	4XL



GENERAL-PURPOSE SAFETY VESTS are made from 100% polyester mesh fabric with matching tricot bindings. They come with 1" silver reflective stripes for high visibility. Features include a hook-and-loop front and elastic-strapped sides. 19" x 48".

P/N	DESCRIPTION
TV15	Safety Vest, Orange
TV55	Safety Vest, Lime

Class 2 **MESH SAFETY VESTS** are made of polyester with 2" glass bead reflective tape. Tricot bindings and hook-and-loop closures standard. Meets ANSI 107 Class 2 Standards. Lime.

P/N	DESCRIPTION	SIZE
SV2C1LM	Mesh Safety Vest	MD
SV2C1LL	Mesh Safety Vest	LG
SV2C1LXL	Mesh Safety Vest	XL
SV2C1L2XL	Mesh Safety Vest	2XL
SV2C1L3XL	Mesh Safety Vest	3XL
SV2C1L4XL	Mesh Safety Vest	4XL
SV2C1L5XL	Mesh Safety Vest	5XL





BTCY

BARRICADE TAPES

ECONOMY BARRICADE TAPES are made from 3 mil polyethylene material. 3" x 1000' rolls.

P/N	DESCRIPTION
BTDR	"Danger" Economy Barricade Tape, Red/Black
BTCY	"Caution" Economy Barricade Tape, Yellow/Black



SLYFL

Our **BARRICADE TAPES** are made of 2.5 mil polyethylene and come in 3" x 1000' rolls for easy handling and storage.

P/N	DESCRIPTION
SLYCC	"Caution" Barricade Tape, Yellow
SLYDNE	"Caution Do Not Enter" Barricade Tape, Yellow
SLYPL	"Police Line Do Not Cross" Barricade Tape, Yellow
SLYFL	"Fire Line Do Not Cross" Barricade Tape, Yellow
TR38	"Danger Do Not Enter" Barricade Tape, Red

→ **More BARRICADE TAPE Available - Call for Pricing.**



TR38

Dispense barricade tape quickly, safely, and efficiently with our **BARRICADE TAPE DISPENSER** or **TAPE HOLDER**.

The **TH42003** dispenser can hold 1000' of 2, 3, or 4 mil tape, is made of polypropylene plastic with notches to secure tape, and cuts a serrated edge for easy dispensing. The **TH1000** holder dispenses 1000' of 2" or 3" barricade tape and includes a steel safety blade for smooth, fast cuts.

P/N	DESCRIPTION
TH42003	Barricade Tape Dispenser
TH1000	Barricade Tape Holder



TH42003 w/ SLYPL In Use



TH1000 w/ SLYCC In Use



YAT704

MARKING TAPES

AISLE MARKING TAPE is made of tough scuff-resistant vinyl plastic combined with a strong self-adhesive. Great for aisle marking, pipe coding, and many other uses. 2" x 108' roll. Yellow.

P/N	DESCRIPTION
YAT704	Aisle Marking Tape



BY7502

STRIPED WARNING TAPE is made of self-adhesive PVC with a laminated clear film for maximum resistance to traffic, abrasion, and many chemicals. 2" x 54' roll. Black/Yellow.

P/N	DESCRIPTION
BY7502	Striped Warning Tape

FALL PROTECTION

Workman® FULL-BODY HARNESSSES feature **Qwik-Fit™** chest and leg buckles and back D-rings. These lightweight harnesses meet OSHA 1910.66, 1926.502, and ANSI A10.32 and Z359.1 standards. Yellow/Black.

NOTE: Weight capacity changes depending on height, weight, and harness size.

P/N	DESCRIPTION	SIZE
FPHNSTD	Full-Body Harness	Standard
FPHNXL	Full-Body Harness	XL

Workman® 6' SHOCK-ABSORBING LANYARDS

provide connections between dorsal D-rings of full-body harnesses and qualified anchors and anchorage connectors. They also have adjustable tear-tape designs to arrest fall forces below 900 lb. Meets ANSI Z359.1 and A10.32. 310 lb capacity. Yellow.

P/N	DESCRIPTION
→ FP6LDS	Lanyard w/ Double Snap
→ FP6LSR	Lanyard w/ Snap & Rebar Hook

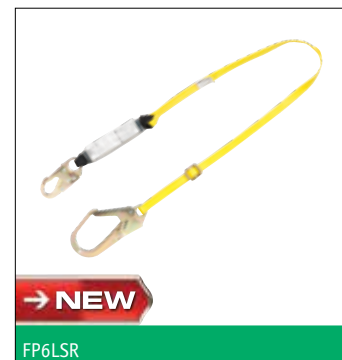

Workman® PFL LANYARD features a solid design with a fast-acting brake mechanism. It comes with rugged impact-absorbing bumpers and a 12' web lifeline with a locking LI snaphook. Meets applicable OSHA regulations only. 400 lb capacity.

P/N	DESCRIPTION
FP12PFL	PFL Lanyard



LOCKOUT/TAGOUT

Safety **LOCKOUT HASPS** provide a safe, proven method of locking out energy sources. Two models are available: the red heavy-duty nylon style or the aluminum scissors type. The nylon model is flexible, unbreakable, dielectric, and heat and cold resistant. The aluminum models have rubber-dipped handles and are available with two different jaw-opening sizes. Both models accommodate up to six padlocks.

P/N	DESCRIPTION
MS01	Lockout Hasp, Nylon
0G80	Lockout Hasp, 1" Aluminum
0G82	Lockout Hasp, 1 1/2" Aluminum

We carry a full range of **BALL** and **BUTTERFLY VALVE LOCKOUTS**, including **BS03D**—the largest ball valve lockout available. All are made of strong polypropylene plastic, which is highly resistant to cracking and abrasion, and they are fully dielectric and resistant to extreme temperature changes (-50°F to 360°F). The **BS01** can be used to lock valves in the open or closed position. Red.

P/N	DESCRIPTION
BS01	Ball Valve Lockout, 3/8"-1 1/4"
BS02	Ball Valve Lockout, 1 1/2"-2 1/2"
BS03D	Ball Valve Lockout, 2"-8"
BS04D	Universal Butterfly Valve Lockout

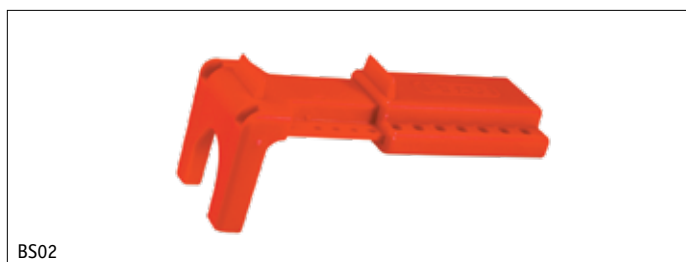
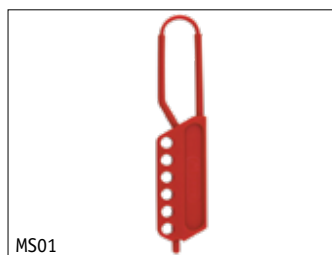



ML480

Ideal for tight spaces and insulated pipes, **Master Lock® ROTATING GATE VALVE LOCKOUTS** come in various diameters to fit over different size valve handles. They can be locked to protect against accidental opening and feature tough yet lightweight dielectric **Zenex™** thermoplastic construction, which easily withstands chemicals and temperature extremes. Their unique, patented, rotating design is also what makes it easy to fit them into tight spaces. Their hi-vis safety labels come in English, French, and Spanish, and their center knockouts can be removed to fit over rising stem gate valves.

P/N	DESCRIPTION
ML480	Gate Valve Lockout, 1"-3" Dia
ML481	Gate Valve Lockout, 2"-5" Dia
ML482	Gate Valve Lockout, 4"-6 1/2" Dia



PGVLR

This **CYLINDER VALVE LOCKOUT** offers additional protection against the release of compressed gas by covering the whole cylinder valve up to 3 1/4" x 6". Red.

P/N	DESCRIPTION
PGVLR	Cylinder Valve Lockout



WHEEL VALVE LOCKOUTS

V-Safe® WHEEL VALVE LOCKOUTS consist of two half moons that completely cover the valve hand wheel. Made of strong dielectric polypropylene plastic, they are highly resistant to cracking, abrasion, and extreme temperature changes (-50°F to 360°F) and are easily modified for rising-stem-type valves. Red.

P/N	DESCRIPTION
VS02	Wheel Valve Lockout, Up to 2 1/2" Dia
VS04	Wheel Valve Lockout, 2 1/2"-5" Dia
VS06	Wheel Valve Lockout, 5"-6 1/2" Dia
VS09D	Wheel Valve Lockout, 6 1/2"-10" Dia
VS13D	Wheel Valve Lockout, 10"-14" Dia



CB03



CB01

C-Safe CIRCUIT BREAKER LOCKOUTS are made of tough molded polyamide plastic and are available to fit single and double pole breakers. The **CB03** can be used with single pole breakers without the through hole, where as the **CB01** fits most major brands of electrical circuit breakers with a padlock hole through the breaker toggle. The **CB04** and **CB02** fit double pole breakers. Red.

P/N	DESCRIPTION
CB03	Single Pole Lockout For Toggles w/o Hole
CB01	Single Pole Lockout For Toggles w/ Hole
CB04	Double Pole Lockout For Toggle Switch w/ Cross Bar
CB02	Double Pole Lockout For Breaker w/ Cross Bar



CB04



CB02

LOCKOUT/TAGOUT CENTERS offer a convenient way to locate and store lockout items. Made of double-molded polystyrene with hanging lock hooks, the **Small Center** measures 24" x 18", while the **Large Center** measures 35" x 24". White.

NOTE: Tags do not have grommets.

CENTER CONTENTS	LTC1	LTC2
Wheel Valve Lockouts, 1"-2½"	2	2
Wheel Valve Lockouts, 2½"-4"	1	1
Wheel Valve Lockouts, 5"-6½"	1	1
Wheel Valve Lockouts, 6½"-10"	-	1
Ball Valve Lockout, ¾"-1¼"	1	1
Ball Valve Lockout, 1½"-2½"	-	1
Plug Lockout, 110 VAC	2	2
Plug Lockout, 220/550 VAC	1	1
1" Steel Lockout Hasp	1	2
Nylon Lockout Hasp	4	6
"Do Not Operate" Tags	25	25
"Do Not Open" Tags	25	25
"Do Not Start" Tags	-	25
Padlock, Blue	1	4

P/N	DESCRIPTION
LTC1	Small Lockout/Tagout Center
LTC2	Large Lockout/Tagout Center

Constructed of one-piece molded polycarbonate, these **PADLOCK STATIONS** offer excellent durability and impact resistance. They come with snap-on clips for easy padlock and hasp storage and removal. Clear lockable covers are standard too. Yellow.

P/N	DESCRIPTION	H X W X D
→ PS510	Padlock Station (Holds 5–10 Padlocks)	12½"H x 16¼"W x 2½"D
→ PS1020	Padlock Station (Holds 10–20 Padlocks)	15¾"H x 22"W x 2½"D

LOCKOUT TAGS measure 3" x 5¾" and are made of rugged, stain and mildew-resistant 20 mil styrene. Tags come with grommets and zip ties and have "DANGER" headings and striped red borders. Textured surfaces make them easy to write on. Pkg/25.

P/N	DESCRIPTION
ELA290	"Do Not Operate" Tags
ELA255	"Do Not Open" Tags
ELA250	"Do Not Start" Tags

Ideal for work-team lockout situations, the **GROUP LOCK BOX** features solid steel construction with a red enamel finish. 11"L x 6"H x 4½"D.

P/N	DESCRIPTION
GLB01	Group Lock Box

E-Safe LOCK-A-PLUGS are practical positive-locking systems that prevent accidental re-connection by unauthorized personnel. Made of dielectric polypropylene plastic, they feature sliding closures with integrated multiple lockouts. The **LP110** accepts plugs up to 3¼"L x 1¾"W x 1¾"D (½" Dia cable max). The **LP550** accepts plugs up to 6¾"L x 3"W x 3"D (1" Dia cable max). Red.

P/N	DESCRIPTION
LP110	Lock-A-Plug, 110 VAC
LP550	Lock-A-Plug, 220/550 VAC



LTC1



LTC2



PS510



ELA250 FRONT & BACK

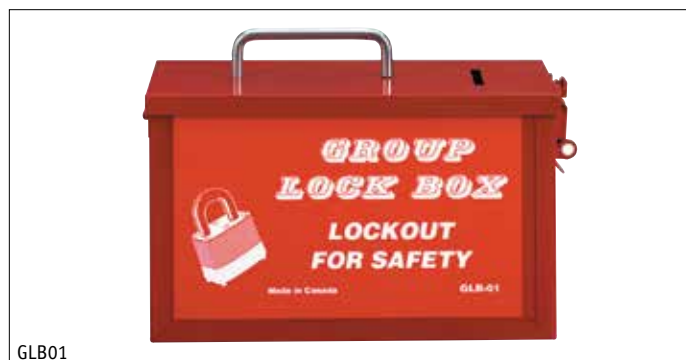

GLB01

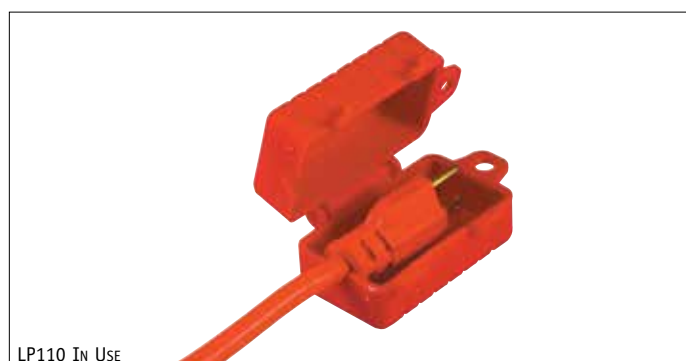

LP110 In Use



M12L

PADLOCKS

Corrosion-resistant **Brooks BRASS PADLOCK** features an all-brass shackle, making it ideal for cabinets and other security requirements where economy and keyed-alike convenience is essential. $\frac{5}{8}$ " inside shackle.

P/N	DESCRIPTION
M12L	Brass Padlock



L40

This **LAMINATED PADLOCK**, from **Master Lock**, features a 4-pin cylinder, laminated steel body, and hardened $\frac{9}{32}$ " Dia steel shackle. It comes keyed differently, making it great for group lock box and high-security applications. $\frac{3}{4}$ " inside shackle.

P/N	DESCRIPTION
L40	Laminated Padlock



ML500KA

Master Lock is a name synonymous with quality padlocks. The keyed-alike **BREAKAWAY STEEL PADLOCK** has a $1\frac{3}{4}$ "-wide laminated steel body for superior strength and comes with two keys and a steel shackle for superior cut resistance. A warded locking mechanism helps minimize jamming caused by dirt and grime. Rustproof. $\frac{13}{16}$ " inside shackle.

NOTE: Locks are keyed alike to #197.

P/N	DESCRIPTION
ML500KA	Breakaway Steel Padlock



SBL66

The **Brooks BREAKAWAY BRASS PADLOCK** safely secures cabinets and other equipment. Designed to be opened with a key (included) or broken away in an emergency. $\frac{7}{8}$ " inside shackle.

P/N	DESCRIPTION
SBL66	Breakaway Brass Padlock



→ NEW

BN15L



→ NEW

TPG15L

NYLON & STEEL SHACKLED PADLOCKS feature non-conductive polymer bodies and reinforced nylon or steel shackles. Write-on labels and one key are standard too. Locks are keyed differently. $\frac{3}{4}$ " inside shackle.

P/N	DESCRIPTION
→ BN15L	Padlock w/ Nylon Shackle, Red
→ TPR15L	Padlock w/ Steel Shackle, Red
→ TPY15L	Padlock w/ Steel Shackle, Yellow
→ TPG15L	Padlock w/ Steel Shackle, Green
→ TPB15L	Padlock w/ Steel Shackle, Blue

An inexpensive locking alternative, this **PLASTIC PADLOCK** must be cut or broken for access. 3/4" inside shackle. Red.

P/N	DESCRIPTION
PPL	Plastic Padlock



PPL

American Lock® ALUMINUM PADLOCKS are corrosion resistant, keyed differently with 5-pin re-keyable cylinders, and feature case-hardened boron alloy steel shackles.

P/N	DESCRIPTION
1106B	Aluminum Padlock, 1 1/2" Shackle, Blue
1106R	Aluminum Padlock, 1 1/2" Shackle, Red
1107B	Aluminum Padlock, 3" Shackle, Blue
1107R	Aluminum Padlock, 3" Shackle, Red



1107B

CABLE TIES

STANDARD CABLE TIES offer high tensile strength with low insertion force. For indoor/outdoor use with a working temperature of -40°F to 185°F. 50 lb tensile strength. UL listed Type 21 and UL Air Handling approved: UL AH-2. Pkg/100.

P/N	DESCRIPTION
SCT7N	Cable Ties, 7", Natural
SCT7UVB	Cable Ties, 7", UV Black
SCT11N	Cable Ties, 11", Natural
SCT11UVB	Cable Ties, 11", UV Black
SCT14N	Cable Ties, 14", Natural
SCT14UVB	Cable Ties, 14", UV Black



SCT7N

HDCT14UVB

HEAVY-DUTY CABLE TIES offer higher tensile strength than the standard version but with the same low insertion force. For use indoors or out with a working temperature of -40°F to 185°F. 120 lb tensile strength. 14". UL listed Type 21 and UL Air Handling approved: UL AH-2. Pkg/100.

P/N	DESCRIPTION
HDCT14N	Heavy-Duty Cable Ties, Natural
HDCT14UVB	Heavy-Duty Cable Ties, UV Black

SAFES

Keep valuables and important documents safe and secure with any of these **Honeywell® SAFES**.

NOTE: Keys are located in the styrofoam at the box bottom.

P/N	DESCRIPTION
S1101	30-Minute Fire Document Chest, 0.15 cu ft
S6104*	Steel Security Box, 0.17 cu ft
S5101	Steel Security Box, 0.36 cu ft
S5113*	Steel Security Box, 0.50 cu ft
S2101*	Brigade Series Steel Fire & Security Safe, 0.52 cu ft

*WHILE QUANTITIES LAST!



S1101



DDPJR893020 In Use



DDPJR893120 In Use



DDPJR893400 In Use

STORAGE

Sure-Grip® EX Classic SAFETY CABINETS, by Justrite, use **U-Loc™** handles and include a cylinder lock and key set. Designed to store flammable liquids safely, these cabinets are constructed of 18 ga double-wall steel with 2" leakproof bottom sumps, leveling feet, dual vents with flame arresters, ground connectors, and powder-coat finishes. Other features include **Haz-Alert™** reflective warning labels and **SpillSlope®** galvanized steel shelving (directs spills to back and bottom of cabinets). Self-closing units come with fusible link-actuated doors that shut at 165°F. Cabinets accept optional padlocks. FM approved and meets OSHA and NFPA requirements. Yellow.

NOTE: The self-closing door style is now being required in states which follow the International Fire Code (IFC) or NFPA I Fire Code. Please contact your local AHJ for specific requirements in your area.

P/N	DESCRIPTION	H X W X D
DDPJR893020	30 gal Safety, 1 Shelf Self-Closing Doors - IFC	44" x 43" x 18"
DDPJR894500	45 gal Safety, 2 Shelves Manual Doors	65" x 43" x 18"
DDPJR894520	45 gal Safety, 2 Shelves Self-Closing Doors - IFC	65" x 43" x 18"
DDPJR896000	60 gal Safety, 2 Shelves Manual Doors	65" x 34" x 34"
DDPJR896020	60 gal Safety, 2 Shelves Self-Closing Doors - IFC	65" x 34" x 34"
DDPJR899000	90 gal Safety, 2 Shelves Manual Doors	65" x 43" x 34"
DDPJR899020	90 gal Safety, 2 Shelves Self-Closing Doors - IFC	65" x 43" x 34"
DDPJR29937	Steel Shelf For 30 & 45 gal Cabinets	

→ **More SAFETY CABINETS**
Available - Call for Pricing.

Justrite® Sure-Grip® EX CORNER SAFETY CABINETS have a unique 90° profile on the back, allowing for corner placement, saving space. Features include 18 ga double-walled construction (with air space), leakproof 2" sumps to collect spills, and rounded corners to reduce the potential of injury. Other features include dual vents, adjustable leveling feet, grounding connectors, **Haz-Alert™** reflective warning labels, and self-closing doors that activate at 165°F. Meets OSHA, NFPA, and IFC requirements. Yellow.

P/N	DESCRIPTION	H X W X D
DDPJR893120	30 gal Corner 1 Adjustable Shelf	44" x 43" x 21 ³ / ₄ "
DDPJR894620	45 gal Corner 2 Adjustable Shelves	65 ¹ / ₄ " x 43" x 21 ³ / ₄ "

Sure-Grip® EX WALL MOUNT SAFETY CABINETS

store small containers without taking up floor space and have the same great features as the **Safety Cabinets**. The 20 gal cabinet has three adjustable shelves, while the 17 gal has one. Cabinets come with mounting hardware. Meets OSHA and NFPA requirements. Yellow.

P/N	DESCRIPTION	H X W X D
DDPJR8917008	17 gal Wall/Bench Manual Doors	24" x 43" x 18"
DDPJR893400	20 gal Wall/Bench Manual Doors - FM	44" x 43" x 12"

Sure-Grip® EX UNDERCOUNTER SAFETY CABINETS

mount flush with other cabinetry and come with back vent openings. They store 22 gal of flammable liquids and include one adjustable shelf. The self-closing-door model activates automatically at 165°F. FM approved and meets OSHA and NFPA requirements. Yellow.

P/N	DESCRIPTION	H X W X D
DDPJR892300	22 gal Undercounter Manual Doors	35" x 35" x 22"
DDPJR892320	22 gal Undercounter Self-Closing Doors - IFC	35" x 35" x 22"

Sure-Grip® EX COMPAC CABINETS fit almost anywhere and provide protection where space is limited. The self-closing door model activates at 165°F, while both versions come with one adjustable shelf. FM approved and meets OSHA and NFPA requirements. Yellow.

P/N	DESCRIPTION	H X W X D
DDPJR891200	12 gal Compac Manual Doors	35" x 23 1/4" x 18"
DDPJR891220	12 gal Compac Self-Closing Doors - IFC	35" x 23 1/4" x 18"
DDPJR891500	15 gal Compac Manual Doors	44" x 23 1/4" x 18"

Sure-Grip® EX PIGGYBACK/COUNTERTOP SAFETY CABINETS are designed to mount on top of standard 30 and 45 gal safety cabinets. They can be used singly or stacked to provide expanded or segregated storage of flammables. These cabinets are wall mountable with manual or self-closing doors (activates at 165°F) and are manufactured to the same specifications as **Justrite's** standard-size safety storage cabinets. Each comes with one adjustable shelf (except 12 gal). Meets OSHA and NFPA requirements. Yellow.

P/N	DESCRIPTION	H X W X D
DDPJR890400	4 gal Countertop Manual Door	22" x 17" x 17"
DDPJR890420	4 gal Countertop Self-Closing Door - IFC	22" x 17" x 17"
DDPJR891300	12 gal Piggyback Manual Doors - FM	18" x 43" x 18"
DDPJR891700	17 gal Piggyback Manual Doors - FM	24" x 43" x 18"

Justrite® Sure-Grip® EX HAZARDOUS MATERIAL SAFETY CABINETS are made to ensure full compliance when storing hazardous materials and have all the same great features as the **Safety Cabinets**. All models come with self-closing doors, that activate at 165°F, as well as **U-Loc™** cylinder locks and a packet of 10 chemical-specific labels. The 30 gal cabinet has one shelf, all others have two. FM approved and meets NFPA and IFC requirements. Blue.

NOTE: These cabinets are required by either the IFC or NFPA 1. Contact your AHJ with further questions.

P/N	DESCRIPTION	H X W X D
DDPJR863028	30 gal Hazardous	44" x 43" x 18"
DDPJR864528	45 gal Hazardous	65" x 43" x 18"
DDPJR866028	60 gal Hazardous	65" x 34" x 34"
DDPJR869028	90 gal Hazardous	65" x 43" x 34"



DDPJR892300 In Use



DDPJR891200 In Use



DDPJR891300 In Use



DDPJR869028 In Use



DDPJR893011 In Use

Sure-Grip® EX Class III COMBUSTIBLE SAFETY

CABINETS provide central storage and organization for your paints, inks, or other combustible liquids. They feature 18 ga double-wall construction with insulating air barriers, 3-point locks, dual vents with built-in flame arresters, adjustable (1½") leveling feet, and 2" leakproof sills. The self-closing-door model releases automatically at 165°F, and both versions include three adjustable shelves. FM approved and meets OSHA and NFPA requirements. Red.

P/N	DESCRIPTION	H X W X D
DDPJR893011	40 gal Combustible Manual Doors	44" x 43" x 18"
DDPJR893031	40 gal Combustible Self-Closing Doors - IFC	44" x 43" x 18"



DDPJR8991053 In Use

Sure-Grip® EX FLAMMABLE WASTE DRUM

STORAGE CABINETS are designed for temporary, vertical on-site storage of flammable or combustible wastes. They feature double-wall construction, adjustable leveler feet, three-point door locks with keys, and 2" leakproof sills. The 55 gal models accommodate drums equipped with **Justrite® Pumps**, and all models come standard with a single shelf. Meets OSHA and NFPA requirements. White.

P/N	DESCRIPTION	H X W X D
DDPJR8930053	Waste Holds (6) 5 gal Cans, Manual Doors - FM	44" x 43" x 18"
DDPJR8962053	Waste Holds (1) 55 gal Drum, Manual Doors - FM	65" x 34" x 34"
DDPJR8991053	Waste Holds (2) 55 gal Drums, Manual Doors	65" x 59" x 34"

Featuring polyethylene construction, the DOCUMENT

STORAGE BOX is impervious to dirt and moisture. It comes standard with heavy-duty double-sided tape for easy installation and a flip top with snap latches for instant access. Measures 12½"H x 10¼"W x 2¼"D (outside) and 11½"H x 8¹³/₁₆"W x 1⁵/₈"D (inside). Red.

P/N	DESCRIPTION
JR23303	Storage Box w/ (2) Blank Labels, & Labels Printed (1) SDS & (1) Instruction Manual
JR23310	(1) SDS Label, (1) Instruction Manual Label, & (2) Blank Labels (Pkg/20, Priced ea)



JR23303 In Use

CYLINDER LOCKERS safely secure LPG and compressed gas cylinders, deterring theft and unauthorized access. Constructed of 100% welded aluminum, they will not rust, corrode, or discolor. They come with solid-aluminum slanted roof panels that shed water and ice. Complies with NFPA 58 and OSHA 1910.110 requirements.

P/N	DESCRIPTION	H X W X D
DDPJR23001	Horizontal 4-Cylinder Locker	33½" x 30" x 32"
DDPJR23002	Horizontal 6-Cylinder Locker	49½" x 30" x 32"
DDPJR23003	Horizontal 8-Cylinder Locker	65" x 30" x 32"
DDPJR23004	Horizontal 12-Cylinder Locker	49½" x 60" x 32"
DDPJR23005	Horizontal 16-Cylinder Locker	65" x 60" x 32"
DDPJR23006	Vertical 10-Cylinder Locker	65" x 30" x 32"
DDPJR23007	Vertical 20-Cylinder Locker	65" x 60" x 32"
DDPJR23008	Combo Vert/Horiz Locker	65" x 60" x 32"



DDPJR23007 In Use

TYPE I SAFETY CANS, from **Justrite**, are an economical choice for storing flammable liquids. They have self-closing leak-proof lids that prevent ruptures from pressure build-up, plus they control vapors and spills. These cans are made from high-grade, powder-coated steel that resists chemicals. Meets OSHA and NFPA requirements and are certified by FM, TUV, UL, and ULC. Accepted under CARB regulations.

NOTE: To avoid misuse and reduce the potential for incompatible mixtures, different color cans differentiate liquids and are affixed with warning labels that have an extra-large ID zone for user labeling of contents. **Red** is used, and OSHA accepted, for flammable liquids. **Blue** is often used to store kerosene. **Yellow** cans usually store diesel fuel, and **Green** cans are primarily used to store oil.

P/N	DESCRIPTION	WEIGHT	H X DIA (OUTER)
JR7110100	1 gal Type I, Red	4 lb	11" x 9½"
JR7110300	1 gal Type I, Blue	4 lb	11" x 9½"
JR7110200	1 gal Type I, Yellow	4 lb	11" x 9½"
JR7120100	2 gal Type I, Red	6 lb	13¾" x 9½"
JR7120300	2 gal Type I, Blue	6 lb	13¾" x 9½"
JR7120200	2 gal Type I, Yellow	6 lb	13¾" x 9½"
JR7125100	2.5 gal Type I, Red	6 lb	11½" x 11¾"
JR7125300	2.5 gal Type I, Blue	6 lb	11½" x 11¾"
JR7125200	2.5 gal Type I, Yellow	6 lb	11½" x 11¾"
JR7150100	5 gal Type I, Red	8 lb	16⅞" x 11¾"
JR7150300	5 gal Type I, Blue	8 lb	16⅞" x 11¾"
JR7150400	5 gal Type I, Green	8 lb	16⅞" x 11¾"
JR7150200	5 gal Type I, Yellow	8 lb	16⅞" x 11¾"



JR7150300, JR7150400, JR7150200

The **Justrite® FUNNEL** is easy to attach to **Type I Cans**, offering virtually splash-free controlled pouring—even into small openings. Its hinged design allows the user to fill the can without removing it. Made of durable polypropylene. Yellow.

P/N	DESCRIPTION	WEIGHT	H X DIA (OUTER)
JR11202Y	Funnel Fits Type I Steel Cans, 1 gal & Up	1 lb	11¼" x 1½"



JR11202Y



JR14160D

Justrite's TYPE I OVAL SAFETY CAN is for carrying flammable liquids and features high-density polyethylene construction with stainless steel fittings. Dent proof and resistant to punctures, acids, and corrosives, it is made with a current-carrying carbon insert, embedded in its rib, that prevents arcing. FM approved and meets OSHA and NFPA requirements. Red.

P/N	DESCRIPTION	WEIGHT	H X W X D
JR14160D	1 gal Type I Oval	2.5 lb	12 ³ / ₄ " x 7 ⁵ / ₈ " x 4 ⁵ / ₈ "

TYPE II ACCUFLOW™ SAFETY CANS encase flammable liquids with high-grade powder-coated steel to resist solvents, acids, and alkalis. They feature **Safe-Squeeze®** triggers and built-in flexible metal hoses for spill-free pouring, while their swinging handle design offers easy handling and stainless steel flame arresters stop flashback ignition. Relief mechanisms vent pressure at 3-5 psig. Meets OSHA and NFPA requirements and are certified by FM, TUV, UL, and ULC. Accepted under CARB regulations. Red.



JR7250130

P/N	DESCRIPTION	WEIGHT	H X DIA
JR7210120	1 gal Type II, 5/8" x 9" Hose	7 lb	10 ¹ / ₂ " x 9 ¹ / ₂ "
JR7220120	2 gal Type II, 5/8" x 9" Hose	8 lb	13 ¹ / ₄ " x 9 ¹ / ₂ "
JR7225130	2.5 gal Type II, 1" x 9" Hose	8 lb	12" x 11 ³ / ₄ "
JR7250120	5 gal Type II, 5/8" x 9" Hose	10 lb	17 ¹ / ₂ " x 11 ³ / ₄ "
JR7250130	5 gal Type II, 1" x 9" Hose	10 lb	17 ¹ / ₂ " x 11 ³ / ₄ "

This **TYPE II ACCUFLOW™ TRANSPORT SAFETY CAN** has the same great features as **Justrite's Type II Cans** plus heavy-duty roll bar construction, protecting the fill and pouring mechanisms from damage. The roll bars provide excellent handholds, while the can's fusible link bracket engages at 165°F, preventing dangerous fume build-up at elevated temperatures. Meets DOT, HM-181, OSHA, NFPA, and UN requirements. Accepted under CARB regulations. Red.



DDPJ7350130

P/N	DESCRIPTION	WEIGHT	H X DIA
DDPJ7350130	5 gal DOT Type II, 1" x 9" Hose	12.5 lb	18 ¹ / ₂ " x 11 ³ / ₄ "

DISPENSING BOTTLE features low-density polyethylene construction. Squeezing it produces a fine stream of liquid, and its stem can be shaped as needed to dispense into tight areas. 16 oz.



JR14009



JR08805D

P/N	DESCRIPTION	H X DIA
JR14009	Squeeze Bottle	7 ¹ / ₂ " x 3"

The **DRUM BUNG WRENCH** is made of rugged, non-sparking, and corrosive-resistant brass alloy. It fits any of seven alternate 2" or 3/4" styles commonly used on drums, and its handle design protects the hand when in use.

P/N	DESCRIPTION	WEIGHT
JR08805D	Drum Wrench	2 lb

DISPOSAL

OILY WASTE CANS feature durable steel construction. Other features include powder-coated finishes for chemical resistance, foot pedals for hands-free operation, and ventilated bases to help prevent combustion. UL listed, FM approved, and TUV certified. Meets OSHA requirements. Red.

P/N	DESCRIPTION	WEIGHT	H X DIA
JR09100	6 gal Oily Waste	9.5 lb	15 ⁷ / ₈ " x 11 ⁷ / ₈ "
JR09300	10 gal Oily Waste	12.5 lb	18 ¹ / ₄ " x 13 ¹⁵ / ₁₆ "
JR09500	14 gal Oily Waste	15.5 lb	20 ¹ / ₄ " x 16 ¹ / ₁₆ "
DDPJR09700	21 gal Oily Waste	22 lb	23 ⁷ / ₁₆ " x 18 ³ / ₈ "



JR09100

Justrite's DRUM FUNNEL features a large 10³/₄" mouth for fast-dumping with minimal spills and a hinged fusible-link-actuated cover. A 6" brass flame arrester and 2" NPS thread are standard. FM approved. Red.

P/N	DESCRIPTION	H X DIA
DDPJR08207	Drum Funnel	10" x 10 ³ / ₄ "



DDPJR08207

This steel **DRUM COVER** provides an inexpensive way to convert an open-top 55 gal steel drum into a fire-safe receptacle for combustible trash. It features a replaceable fusible link assembly that automatically shuts it in the event of fire, and it comes with a chemically-resistant powder-coat finish. Fits drums 22¹/₂"–22³/₄" in diameter. FM approved. Red.

P/N	DESCRIPTION	WEIGHT
JR26750	Drum Cover	13.5 lb



JR26750

Smokers Cease-Fire® CIGARETTE BUTT RECEPTACLES are a safe, attractive method of cigarette disposal. Their oxygen-restricting design quickly extinguishes butts, reducing the risk of fire. They come with hooded 1¹/₂" openings to keep out rain and other types of trash. Made of high-density, flame-resistant polyethylene, these receptacles won't rust, dent, crack, or peel. Their twist-on lids and removable galvanized steel liner pails provide trouble-free cleaning, while tie-down notches add additional security. Fire tested and FM approved. Measures 38¹/₂" x 16¹/₂".

P/N	DESCRIPTION
JR26800BK	Cease-Fire, Deco Black
JR26800BG	Cease-Fire, Adobe Beige
JR26800T	Cease-Fire, Terra Cotta
JR26800P	Cease-Fire, Pewter Gray
JR26800G	Cease-Fire, Forest Green



JR26800BK, JR26800BG, JR26800T, JR26800P, JR26800G

In Use photos may show items not included or available separately.

FIRST AID KITS AND CABINETS

FIRST AID METAL CABINETS have been specially designed to provide the most complete first aid protection available in each particular size. The balanced assortment of supplies will handle most first aid needs. Cabinets are dust proof and wall mountable. Contents subject to change without notice.

P/N	DESCRIPTION	H X W X D
FA90572	2 Shelf, Full	11" x 15 ¹ / ₄ " x 4 ¹ / ₂ "
FA90574	3 Shelf, Full	17" x 15 ¹ / ₂ " x 5 ³ / ₄ "
FA90576	4 Shelf, Full	17" x 22 ³ / ₄ " x 6"
FA5024MT	2 Shelf (Empty)	10 ¹ / ₄ " x 14 ³ / ₄ " x 4 ⁵ / ₈ "
FA5025MT	3 Shelf (Empty)	16" x 13 ⁷ / ₁₆ " x 5 ¹ / ₂ "
FA6175MT	4 Shelf (Empty)	21 ⁷ / ₈ " x 14 ⁵ / ₁₆ " x 5 ¹ / ₂ "
FAM5061	2 Shelf Pocket Liner	9" x 15" x 1 ¹ / ₈ "
FAM5062	3 Shelf Pocket Liner	15" x 13 ¹ / ₈ " x 1 ¹ / ₈ "
FAM5063	4 Shelf Pocket Liner	22" x 14 ⁵ / ₈ " x 1 ¹ / ₈ "

CABINET CONTENTS:

	FA90572	FA90574	FA90576
Fabric Bandages, 1" x 3"	50	100	100
Antibiotic Ointment Packets	10	-	-
Triple Antibiotic Ointment Packets	-	25	25
First Aid/Burn Cream Packets	12	12	-
Antiseptic Spray, 4 oz	1	1	1
BZK Antiseptic Towelettes	-	-	50
CPR Mask w/ One Way Valve	1	1	1
Burn Dressing, 4" x 4"	1	1	2
Burn Spray, 4 oz	1	1	1
Instant Cold Compress, 4" x 5"	1	-	-
Instant Cold Compress, 6" x 9"	-	1	1
Sterile Eye Pads (4) & Strips (4)	1	1	-
Eyewash, 1 oz	1	-	-
Eyewash, 4 oz	-	1	1
Eyewash, 1 oz w/ Eye Pads (2) & Strips (2)	-	-	1
Conforming Gauze Rolls, 2"	2	1	10
Scissors	1	1	1
Triangular Sling/Bandage, 40" x 40" x 56"	1	2	2
Tweezers	1	1	1
Plastic Bandages, 3/4" x 3"	100	-	-
Plastic Bandages, 1" x 3"	-	-	100
Fabric Bandages, 2" x 3"	-	10	-
Hand Sanitizer Packets, 0.9 g	10	10	-
Hand Sanitizer, 4 oz	-	-	1
First Aid Tape, 1/2" x 5 yd	1	1	-
Tri-Cut Waterproof Tape w/ Plastic Spool	-	-	1
Knuckle Fabric Bandages	8	25	40
Fingertip Fabric Bandages	10	25	40
Gauze Dressing Pads, 2" x 2"	-	10	24
Gauze Dressing Pads, 3" x 3"	4	10	24
Gauze Dressing Pads, 4" x 4"	-	10	-
Sterile Gauze Bandage, 4" x 4 yd	-	-	1
Padded Splint	-	-	1
Alcohol Wipes	20	100	100
Aspirin Tablets, Pkg/2	25	-	125
Non-Aspirin Tablets, Pkg/2	25	50	-
Ibuprofen Tablets, Pkg/2	-	-	125
Cotton Tipped Applicators, 3"	-	100	-
Elastic Bandage, 4" x 5 yd	-	1	1
Hema-Flex 5" x 9" Trauma Pad (1), 4" x 4" Gauze (1), Nitrile Gloves (2)	1	1	1
Trauma Pad, 5" x 9"	1	1	3
Nitrile Exam Gloves	2	10	10
Antacid Tablets, Pkg/2	-	50	125
Ammonia Inhalants	-	-	10
Tourniquet	-	-	1
Povidone-Iodine Infection Control Wipes	-	-	50
Non-Stick Pads, 3" x 4"	-	-	50
Patch Fabric Bandages, 2" x 4"	-	-	25
First Aid Guide	1	1	1



FA90572



FA90574



FA90576

These **STEEL FIRST AID CABINETS** have been specially designed to provide the most complete first aid protection available in each particular size. The balanced assortment of supplies will handle most first aid needs. Each cabinet is wall mountable and comes with a carrying handle. Contents subject to change without notice.

P/N	DESCRIPTION	H X W X D
FA6135	First Aid Cabinet, 2 Shelf	10 ³ / ₄ " x 15 ¹ / ₂ " x 4 ³ / ₄ "
FA6155	First Aid Cabinet, 3 Shelf	16 ¹ / ₂ " x 13 ³ / ₄ " x 5 ¹ / ₂ "
FA6175	First Aid Cabinet, 4 Shelf	15 ¹ / ₄ " x 22 ¹ / ₄ " x 5 ³ / ₄ "

CABINET CONTENTS:

	FA6135	FA6155	FA6175
Plastic Bandages, 3/4" x 3"	100	-	-
Plastic Bandages, 1" x 3"	100	-	-
Heavy Woven Fabric Bandages, 1" x 3"	-	50	50
Patch Fabric Bandages, 2" x 3"	-	10	25
Patch Fabric Bandages, 2" x 4"	6	-	-
Knuckle Fabric Bandages	8	-	-
Fingertip Fabric Bandages	10	-	-
Heavy Woven Knuckle Bandages	-	25	25
Heavy Woven Fingertip Bandages	-	25	25
Gauze Dressing Pads, 2" x 2"	-	10	10
Gauze Dressing Pads, 3" x 3"	10	10	10
Gauze Dressing Pads, 4" x 4"	-	10	10
Hema-Seal Bandage & Compress w/ Gloves	1	1	1
Sterile Gauze Bandage, 2"	1	1	2
Sterile Gauze Bandage, 4"	1	1	2
Waterproof Adhesive Tape, 1" x 5 yd	1	-	-
Tri-Cut Adhesive Tape, 2"	-	1	1
Triangular Sling/Bandage, 40" x 40" x 56"	1	2	2
Alcohol Wipes	100	100	100
First Aid/Burn Cream Packets	12	25	25
Triple Antibiotic Ointment Packets	12	25	25
BZK Antiseptic Wipes	10	25	25
Eyewash, 4 oz w/ Sterile Eye Cup, Pads, & Strips	1	1	1
Antiseptic Spray, 4 oz	1	1	1
Burn Spray, 4 oz	1	1	1
Extra-Strength Non-Aspirin Tablets, Pkg/2	25	25	25
Aspirin Tablets, Pkg/2	-	-	25
Nasal Decongestant Tablets, Pkg/2	-	-	25
Ibuprofen Tablets, Pkg/2	-	-	25
Antacid Tablets, Pkg/2	-	-	25
Cotton Tip Applicators, 3"	-	100	100
Instant Cold Pack, 6" x 9"	1	1	2
Elastic Bandages, 4" x 5 yd	1	1	1
Exam Gloves	10	10	10
Scissors	1	1	1
Tweezers	1	1	1
First Aid Guide	1	1	1



FA6135



FA6155



FA6175



FA1000



FA1050



FA1001

Eliminate disorganized first aid cabinets with **FOOD INDUSTRY SMARTCOMPLIANCE KITS**. Their unique cabinet designs have clearly marked compartments that are easy to use, while their **Smart Tab EZRefill™ Systems** keep track of contents. You can even add expansion pockets to meet your particular needs. Contents subject to change without notice.

P/N	DESCRIPTION	H X W X D
FA1000	Large Workplace First Aid Kit w/ Medications, Plastic	13" x 14" x 4 1/8"
FA1001RC	Red Cross Workplace First Aid Kit w/o Medications, Plastic	13" x 14" x 4 1/8"
FA1001	Medium Workplace First Aid Kit w/o Medications, Metal	12" x 9 1/2" x 3 1/8"
FA1050	Large Workplace First Aid Kit w/o Medications, Plastic	13" x 14" x 4 1/8"

KIT CONTENTS	FA1000	FA1001RC	FA1001	FA1050
Plastic Bandages, 3/4" x 3"	25	25	25	25
Plastic Bandages, 1 1/2" x 1 1/2"	10	10	-	10
Fabric Bandages, 1" x 3"	25	25	25	25
Fingertip Fabric Bandages	10	10	-	10
Knuckle Fabric Bandages	10	10	-	10
Knuckle (5) & Fingertip Bandages (5)	-	-	1	-
Elastic Bandage Wrap, 2" x 5 yd	-	1	-	1
Butterfly Wound Closures	10	10	-	10
Triangular Sling/Bandage, 40" x 40" x 56"	1	1	1	1
Gauze Dressing Pads, 2" x 2"	10	10	-	10
Gauze Dressing Pads, 3" x 3"	10	10	10	10
Conforming Gauze Roll, 2"	1	1	1	1
Conforming Gauze Roll, 3"	1	1	1	1
Trauma Pad, 5" x 9"	1	1	1	1
Alcohol Wipes	20	20	-	20
BZK Antiseptic Wipes	10	20	10	20
Castile Soap Towelettes	-	10	-	10
First Aid/Burn Cream Packets	10	10	10	10
Antibiotic Ointment Packets	10	10	10	10
First Aid Tape, 1/2" x 10 yd	1	1	1	1
Scissors	1	1	1	1
Moleskin (Blister Prevention), 2"	-	10	-	10
Exam-Quality Nitrile Gloves	4	4	4	4
Stainless Steel Tweezers	1	1	1	1
CPR Face Shield (1) & Nitrile Gloves (2)	1	1	-	1
Extra-Strength Non-Aspirin Tablets, Pkg/2	10	-	-	-
Ibuprofen Tablets, Pkg/2	10	-	-	-
Aspirin Tablets, Pkg/2	10	-	-	-
First Aid Guide	1	1	1	1
Antacid Tablets, Pkg/2	-	-	25	25
Cotton Tip Applicators, 3"	-	100	100	100
Instant Cold Pack, 6" x 9"	1	1	2	2
Elastic Bandages, 4" x 5 yd	1	1	1	1
Exam Gloves	10	10	10	10
Scissors	1	1	1	1
Tweezers	1	1	1	1
First Aid Guide	1	1	1	1

Eliminate disorganized and missing supplies in your first aid cabinets with **FOOD INDUSTRY SMARTCOMPLIANCE KITS**. Their unique cabinet designs have clearly marked compartments that are easy to use. Plus their **Smart Tab EZRefill™ Systems** keep track of contents. You can add expansion pockets, too, to meet your particular needs. Contents subject to change without notice.

P/N	DESCRIPTION	H X W X D
FA1301	Large Food Industry First Aid Kit, Plastic	13" x 14" x 4 1/8"
FA1350	Medium Food Industry First Aid Kit, Metal	12" x 9 1/2" x 3 1/8"

KIT CONTENTS	FA1301	FA1350
Metal Detectable Visible Blue Bandage, 1" x 3"	50	50
Knuckle Metal Detectable Visible Blue Bandage	20	20
Fingertip Metal Detectable Visible Blue Bandage	20	20
Bandage Protectant/Finger Cot	50	-
Elastic Bandage Wrap, 2" x 5 yd	1	-
Triangular Sling/Bandage, 40" x 40" x 56"	1	1
Gauze Dressing Pads, 2" x 2"	10	-
Gauze Dressing Pads, 3" x 3"	10	10
Conforming Gauze Roll, 2"	1	1
Conforming Gauze Pad, 3"	1	-
Trauma Pad, 5" x 9"	1	1
Alcohol Wipes	10	-
BZK Antiseptic Towelettes	20	10
Burn Relief, 3.5 g	6	6
First Aid/Burn Cream	10	-
Antibiotic Ointment	10	10
Cloth First Aid Tape, 1" x 5 yd	1	1
First Aid Tape, 1/2" x 10 yd	1	-
Scissors	1	1
Eyewash, 1 oz	1	-
2" Moleskin, Blister Prevention	10	-
Exam-Quality Nitrile Gloves	4	4
Stainless Steel Tweezers	1	1
First Aid Guide	1	1

FIRST AID RESPONDER KIT contains essential first aid products for medical emergencies in a semi-rigid bag with a carrying handle and padded shoulder strap. Contents subject to change without notice.

P/N	DESCRIPTION	H X W X D
FA510FR	First Aid Responder Kit	10 3/4" x 13 3/4" x 3"

KIT CONTENTS
Plastic Bandages, 3/4" x 3" (48)
Gauze Dressing Pads, 2" x 2" (4)
Gauze Dressing Pads, 3" x 3" (4)
Gauze Dressing Pads, 4" x 4" (20)
Trauma Pads, 5" x 9" (2)
Trauma Pad, 8" x 10"
Emergency Pressure Dressing
Conforming Gauze Roll, 2" (3)
Triangular Sling/Bandage, 36" w/ 2 Safety Pins (3)
Alcohol Wipes (6)
Burn Relief, 3.5 g (3)
Povidone-Iodine Infection Control Wipes (6)
Tri-Cut First Aid Tape, 2" x 5 yd
Instant Cold Compress, 4" x 5"
Sterile Eye Pads (2)
Eyewash, 4 oz
Biohazard Bag, 24" x 24", 10 gal Capacity
Ziplock Bags, 10" x 12" (2)
CPR One-Way Valve Face Shield, Latex-Free
Emergency Blanket, 52" x 84"
Exam-Quality Nitrile Gloves (4)
Utility Shears, 7 1/4"
Stainless Steel Tweezers, 3 1/2"
First Aid Guide



FA1350



FA510FR



RP144A



BL144



PTD262



BL157



FA90672



FA6100

FIRST AID SIGNS come in a variety of sizes and styles to help meet your particular job requirements. Durable and fade resistant, these signs mount to almost anything—indoors or out.

P/N	DESCRIPTION
G261	Glow-in-the-Dark AED Label, 6" x 8"
PTD261	"Automated External Defibrillator" 3-D Sign, 5" x 6"
BL144	"First Aid Station" Arrow Sign, 8" x 12"
RP144A	"First Aid" ANSI Z535 Sign, 7" x 10"
PTD262	"First Aid" 3-D Sign, 5" x 6"
FAPOSTER	First Aid Poster, 24" x 18"

P/N	DESCRIPTION
BL157	"First Aid Kit Inside" Sign, 4" x 4"

FIRST AID VEHICLE AND UNITIZED KITS

The **25-PERSON ANSI A+ VEHICLE FIRST AID KIT** comes in a weatherproof metal case with an easy-carry handle for simple transport. Wall mountable. Meets or exceeds OSHA regulations and ANSI Z308.1 standards. Contents subject to change without notice.

P/N	DESCRIPTION	H X W X D
FA90672	25 Person Vehicle First Aid Kit, ANSI A+, Metal	7 ¹ / ₄ " x 9 ¹ / ₂ " x 2 ³ / ₄ "

KIT CONTENTS

Alcohol Wipes (20)	Hand Sanitizer Packets (10)
Scissors	Burn Dressing, 4" x 4"
Tweezers	Allergy Tablets, Pkg/2
Ibuprofen Tablets, Pkg/2 (2)	Antacid Tablets, Pkg/2
Instant Cold Compress, 4" x 5"	Triple Antibiotic Ointment Packets (10)
Nitrile Exam Gloves (4)	Eye Pads (2) & Adhesive Strips (2)
Burn Cream Packets (10)	Conforming Gauze Roll, 4"
Triangular Sling/Bandage, 40" x 40" x 56"	Trauma Pads, 5" x 9" (2)
Eyewash, 1 oz	First Aid Tape, 1/2" x 5 yd
Fabric Bandages, 1" x 3" (32)	Gauze Dressing Pads, 4" x 4" (6)
CPR Mask w/ One-Way Valve	First Aid Guide

This **FIRST AID KIT** comes in a weatherproof steel case with an easy carry handle for simple transport. Wall mountable. Contents subject to change without notice.

P/N	DESCRIPTION	H X W X D
FA6100	25-Person First Aid Kit, Steel	9 ¹ / ₂ " x 6 ¹ / ₂ " x 2 ³ / ₄ "

KIT CONTENTS

Plastic Bandages, 1" x 3" (60)	First Aid/Burn Cream Packets (6)
Knuckle Fabric Bandages (4)	Triple Antibiotic Ointment Packets (6)
Fingertip Fabric Bandages (5)	Eyewash, 4 oz
Gauze Dressing Pads, 4" (6)	Eye Pads (2) & Adhesive Strips (2)
Large Wound Pad	Pain Relief Tablets (12)
Conforming Gauze Roll, 4"	Instant Cold Pack, 4" x 5"
Triangular Sling/Bandage, 40" x 40" x 56"	Aspirin Tablets, Pkg/2 (3)
First Aid Tape, 1/2" x 5 yd	Scissors
Nitrile Exam Gloves (4)	Forceps
BZK Antiseptic Wipes (30)	Red Cross First Aid Guide
Trauma Pad, 5" x 9"	

This **25-PERSON ANSI A+ FIRST AID KIT** comes in a weatherproof plastic case with an easy-carry handle for simple transport. Wall mountable. Meets or exceeds OSHA regulations and ANSI Z308.1 standards. Contents subject to change without notice.

P/N	DESCRIPTION	H X W X D
FA90589	25-Person ANSI A+ First Aid Kit, Plastic	8" x 9" x 2 1/2"

KIT CONTENTS

Plastic Bandages, 1" x 3" (50)	Instant Cold Compress, 4" x 5"
Knuckle Fabric Bandages (5)	Burn Dressing, 4" x 4"
Fingertip Fabric Bandages (5)	First Aid/Burn Cream Packets (10)
Gauze Dressing Pads, 3" x 3" (6)	Hand Sanitizer Packets (10)
Conforming Gauze Roll, 2"	Sterile Eye Pads (2)
Trauma Pads, 5" x 9" (2)	Eyewash, 1 oz
Triangular Sling/Bandage, 40" x 40" x 56"	CPR Mask w/ One Way Valve
Aspirin Tablets, Pkg/2 (6)	Nitrile Exam Gloves (4)
BZK Antiseptic Towelettes (12)	Scissors
Triple Antibiotic Ointment Packets (10)	Tweezers
Insect Sting Relief Wipes (3)	First Aid Guide
First Aid Tape, 1/2" x 5 yd	



FA90589

The **50-PERSON ANSI A+ VEHICLE FIRST AID KIT** comes in a weatherproof metal case with an easy-carry handle for simple transport. Wall mountable. Meets or exceeds OSHA regulations and ANSI Z308.1 standards. Contents subject to change without notice.

P/N	DESCRIPTION	H X W X D
FA90673	50-Person ANSI A+ Vehicle First Aid Kit, Metal	10" x 9 1/2" x 2 3/4"

KIT CONTENTS

Plastic Bandages, 1" x 3" (100)	First Aid Tape, 1/2" x 5 yd (2)
Knuckle Fabric Bandages (4)	Instant Cold Compress, 4" x 5" (2)
Fingertip Fabric Bandages (5)	Burn Dressing, 4" x 4"
Gauze Dressing Pads, 4" x 4" (12)	Burn Cream Packets (20)
Conforming Gauze Roll, 4" (2)	Hand Sanitizer Packets (10)
Trauma Pads, 5" x 9" (2)	Eyewash, 4 oz & Sterile Eye Cup (2)
Aspirin Tablets, Pkg/2 (6)	Eye Pads (2) & Adhesive Strips (2)
Antacid Tablets, Pkg/2 (6)	CPR Mask w/ One-Way Valve
Alcohol Wipes (40)	Nitrile Exam Gloves (4)
Triple Antibiotic Ointment Packets (20)	Scissors
PVP Iodine Wipes (10)	Tweezers
Elastic Bandage, 2" x 5 yd	First Aid Guide
Triangular Sling/Bandage, 40" x 40" x 56" (2)	



FA90673

This **50-PERSON VEHICLE FIRST AID KIT** comes in a rugged, weatherproof steel case, keeping contents free of moisture or dust. Contents subject to change without notice.

P/N	DESCRIPTION	H X W X D
FA6450	50-Person Vehicle First Aid Kit, Steel	9 1/2" x 14" x 2 3/4"

KIT CONTENTS

Plastic Bandages, 1" x 3" (100)	Pain Relief Tablets (24)
Gauze Dressing Pads, 4" x 4" (10)	Eyewash 4 oz
Wound Pad, Large (2)	Eye Pads w/ Strips (8)
Gauze Bandages, 4" (2)	Sterile Eye Cup
Triangular Bandages (2)	Cold Packs
Adhesive Tape (2)	Elastic Bandage, 2"
Exam Gloves (4)	Scissors
Antiseptic Wipes (60)	Forceps
First Aid/Burn Cream Packets (12)	First Aid Guide
Triple Antibiotic Ointment Packets (12)	



FA6450



FA90754

The **10-PERSON ANSI A FIRST AID KIT** comes in a weatherproof plastic case with an easy-carry handle for simple transport. Wall mountable. Meets or exceeds OSHA regulations and ANSI Z308.1 standards. Contents subject to change without notice.

P/N	DESCRIPTION	H X W X D
FA90754	10-Person ANSI A First Aid Kit, Plastic	5" x 8" x 3"

KIT CONTENTS

Plastic Bandages, 1" x 3" (16)	Burn Dressing, 4" x 4"
Gauze Dressing Pads, 3" x 3" (2)	First Aid/Burn Cream Packets (10)
Conforming Gauze Roll, 2"	Hand Sanitizer Packets (6)
Trauma Pads, 5" x 9" (2)	Sterile Eye Pads (2)
Triangular Sling/Bandage, 40" x 40" x 56"	Eyewash, 1 oz
BZK Antiseptic Towelettes (10)	CPR Mask w/ One Way Valve
Triple Antibiotic Ointment Packets (10)	Nitrile Exam Gloves (4)
First Aid Tape, 1/2" x 5 yd	Scissors
Instant Cold Compress, 4" x 5"	First Aid Guide



FA6060

10-PERSON FIRST AID KIT comes in a weatherproof plastic case with an easy-carry handle for simple transport. Kit is wall mountable and comes with thermo-formed trays to keep items organized and accessible. Contents subject to change without notice.

P/N	DESCRIPTION	H X W X D
FA6060	10-Person First Aid Kit, Plastic	4 1/2" x 7 1/2" x 2 3/4"

KIT CONTENTS

Plastic Bandages, 1" x 3" (16)	Nitrile Exam Gloves (4)
Fingertip Fabric Bandages (2)	BZK Antiseptic Towelettes (10)
Knuckle Fabric Bandages (2)	First Aid/Burn Cream Packets (10)
Gauze Dressing Pads, 3" (4)	Triple Antibiotic Ointment Packets (6)
Wound Pad, Large	Scissors
Gauze Bandage, 2"	Forceps
Triangular Bandage, 40"	Red Cross First Aid Guide
First Aid Tape, 1" x 5 yd	



FA5011

10-UNIT FIRST AID KIT comes in a weatherproof plastic case with an easy-carry handle for simple transport. Kit is wall mountable and comes with color-coded boxes to keep items organized and accessible. Contents subject to change without notice.

P/N	DESCRIPTION	H X W X D
FA5011	#10 Unitized First Aid Kit, Plastic	4 1/2" x 7 1/2" x 2 3/4"

KIT CONTENTS

Fabric Bandages, 1" x 3" (16)	First Aid/Burn Cream Packets (12)
Gauze Dressing Pads, 3" (4)	Triple Antibiotic Ointment Packets (12)
Hema-Flex Bandage Compress	1/2" x 5 yd First Aid Tape
Triangular Sling/Bandage, 40" x 40" x 56"	Nitrile Exam Gloves (4)
BZK Antiseptic Towelettes (10)	First Aid Guide

16-UNIT FIRST AID KIT comes in a weatherproof plastic case with an easy-carry handle for simple transport. Kit is wall mountable and comes with color-coded boxes to keep items organized and accessible. Contents subject to change without notice.

P/N	DESCRIPTION	H X W X D
FA5211	#16 Unitized First Aid Kit, Plastic	6 1/2" x 9 1/2" x 2 3/4"

KIT CONTENTS

Fabric Bandages, 1" x 3" (16)	First Aid/Burn Cream Packets (12)
Fingertip Fabric Bandages (5)	Triple Antibiotic Ointment Packets (12)
Fabric Knuckle Bandages (4)	First Aid Tape, 1/2" x 5 yd (2)
Fabric Bandages, Extra Large (6)	Instant Cold Compress, 4" x 5"
Gauze Dressing Pads, 3" x 3" (4)	Eyewash, 1 oz w/ (2) Pads & Strips
Hema-Flex Bandage Compress	Nitrile Exam Gloves (4)
Triangular Sling/Bandage, 40" x 40" x 56"	First Aid Guide
BZK Antiseptic Towellets (10)	



FA5211

SNAKE BITE KIT contains everything needed to treat a venomous snake bite. 4" x 2 1/4" x 1 1/4". Contents subject to change without notice.

P/N	DESCRIPTION	H X W X D
→ FA7103	Snake Bite Kit	4" x 2 3/4" x 1 1/4"

KIT CONTENTS

Venom Extraction Pump (1)	Adhesive Sheer Plastic Bandages (2)
Rubber Tourniquet (1)	Alcohol Wipes (2)
Scalpel, Blade Disposable (1)	Ammonia Inhalants (2)



→ **NEW**

FA7103

CPR/BIOHAZARD KITS AND SUPPLIES

The **BODILY FLUID CLEAN-UP KIT** contains the necessary products to maintain a healthy border when working with, cleaning up, or disposing of biohazardous materials. Contents subject to change without notice.

P/N	DESCRIPTION	H X W X D
FA214P	Bodily Fluid Clean Up Kit w/ Disposable Tray	7 1/2" x 4 1/8" x 2 1/4"

KIT CONTENTS

Disposable Gown w/ Full Sleeves	Clear Plastic Bag, 8" x 12"
Eye Shield w/ Ear Loop Mask	Germicidal Wipes, 5" x 8" (2)
Fluid Control Solidifier Pack, 21 g	Personal Antimicrobial Wipes, 5" x 8" (2)
Biohazard Scoop, 8"	Disposable Towel
Biohazard Bag, 24" x 24", 10 gal Capacity	Exam-Quality Vinyl Gloves (2)
Twist Ties (2)	Bodily Fluid Pick-Up Guide



FA214P



FA200912

This **BLOODBORNE PATHOGEN/PERSONAL**

PROTECTION KIT comes with eye and mouth protection for safer CPR as well as a waste bag for safe, easy clean up. Kit is wall mountable and made of polypropylene for durability.

P/N	DESCRIPTION	H X W X D
FA200912	Bloodborne Pathogen Kit	8" x 9" x 2 1/2"

KIT CONTENTS

BZK Antiseptic Towelettes (3)	Biohazard Bags, 24" x 24" (2)
Disposable Gown w/ Full Sleeves	Clear Plastic Bags, 8" x 12" (2)
Disposable Bonnet	Disposable Clean-Up Towels (3)
Disposable Shoe Covers, Pair	Germicidal Wipes, 5" x 8" (2)
Eye Shield w/ Ear Loop Mask	Exam-Quality Nitrile Gloves, Pair (2)
Fluid Control Solidifier Pack, 21 g	Bodily Fluid Pick-Up Guide
Biohazard Scoop	Twist Ties (2)
CPR Pack (1): CPR One-Way Face Shield (1), Exam-Quality Nitrile Gloves (2), BZK Antiseptic Towelettes (3), All Latex-Free	



FA216083



FAM949

Incineration-safe, these **DISPOSABLE BIOHAZARD BAGS** are double sealed at the bottom to help prevent breakthroughs.

Each bag is printed with the universal biohazard symbol and "INFECTIOUS WASTE" in English/Spanish and holds 7-10 gal. The **SHARPS BIOHAZARD CONTAINER** holds bio bags and syringes and is puncture resistant, leakproof, and nestable. It comes with a needle remover and translucent lid that seals shut when full.

P/N	DESCRIPTION
FA216083	Disposable Biohazard Bags, 24" x 24", Pkg/25
FAM949	Sharps Biohazard Disposable Container, 1 qt

BANDAGES

These durable **BANDAGES** are latex free, sterile, and individually wrapped.

P/N	DESCRIPTION
FA135	Heavy Woven Fabric Bandages, 3/4" x 3", Pkg/50
FAG160	Heavy Woven Fabric Bandages, 2" x 3", Pkg/25
FAG126	Fingertip Fabric Bandages, 1 3/4" x 2", Pkg/40
FAG124	Knuckle Fabric Bandages, 1 1/2" x 3", Pkg/40
FAG106	Plastic Bandages, 1" x 3", Pkg/100



FAG126



FAG124

BLUE METAL DETECTABLE ADHESIVE BANDAGES

come in a highly visible blue fabric and contain an internal foil for metal detectability.

P/N	DESCRIPTION
FA1650	Metal Detectable Light Woven Fabric Bandages, 1" x 3", Pkg/50
FAG174	Metal Detectable Knuckle Fabric Bandages, Pkg/40
FAG173	Metal Detectable Fingertip Fabric Bandages, Pkg/25



FAG174

ADHESIVE TAPE, WRAPS, AND GAUZE

ADHESIVE TAPE, WRAPS, and COMPRESS.

P/N	DESCRIPTION
FAM685P	Waterproof Adhesive Tape, 1/2" x 5 yd
FA240032	Waterproof Adhesive Tape, 1" x 2 1/2 yd, Pkg/12
→ FA90890	Tri-Cut Waterproof Tape, 2" x 5 yd, Pkg/6
FA25400	Cotton Tipped Applicators, 3", Pkg/100
FA5911	Self-Adherent Bandage Wrap, 2" x 5 yd
FAM697	Elastic Bandage w/ Fasteners, 2" x 5 yd
FA5902	Elastic Bandage w/ Fasteners, 3" x 5 yd
FA4006	Triangular Bandage, 40" x 40" x 56"
FA3700	Multi-Trauma Dressing, 10" x 30"



FA240032



FA90890



FA5911



FA5902

GAUZE PADS

P/N	DESCRIPTION
FA3100	Sterile Gauze Pads, 2" x 2", Pkg/10
FA70624	Sterile Gauze Pads, 2" x 2", Pkg/20
FA3200	Sterile Gauze Pads, 3" x 3", Pkg/10
FA3300	Sterile Gauze Pads, 4" x 4", Pkg/10
FA5600	Sterile Stretch Gauze, 2" x 4 yd
FA5700	Sterile Stretch Gauze, 3" x 4 yd
FA51018	Sterile Conforming Gauze, 4" x 5 yd



FA3300



FA5700

MEDICATIONS

GENERIC MEDICATIONS provide a high-quality alternative to costlier name brands.

P/N	DESCRIPTION
FA90316	Extra-Strength Pain Reliever, Pkg/100
FA90317	Extra-Strength Pain Reliever, Pkg/250
FA90014	Aspirin Tablets, Pkg/100
FA90016	Extra-Strength Non-Aspirin Tablets, Pkg/100
FA40800	Extra-Strength Non-Aspirin Tablets, Pkg/250
FA90015	Ibuprofen, Pkg/100
FA90109	Ibuprofen, Pkg/250
FA90036	Antihistamine/Allergy Relief, Pkg/50
FA90092	Cold & Cough, Pkg/100
FA90033	Cold & Cough, Pkg/250
FA90087	Sinus Relief, Pkg/50
FA90306	Cherry Cough & Sore Throat Lozenges, Pkg/50
FA90034	Cherry Cough & Sore Throat Lozenges, Pkg/125
FA90089	Antacid Tablets, Pkg/100
FA90110	Antacid Tablets, Pkg/250
FA90032	Electrolyte Tablets, Pkg/250



FA90014



FA90036



FA90306

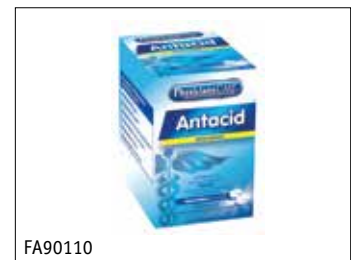

FA90110



FA51025



FA90032

NAME BRAND MEDICATIONS

P/N	DESCRIPTION
FA12406	Alka-Seltzer Original, Pkg/72
FA51025	Pepto Bismol Chewable Tablets, Pkg/30
FA90010	Aleve, Pkg/50
FA15000	Advil, Pkg/100



FA90010



FA21026



FA21004

UNITIZED ITEMS

P/N	DESCRIPTION
FA21026	Nitrile Exam Gloves, Large (4)
FA1002	Plastic Adhesive Bandages, 1" x 3", Pkg/16
FA1008	Fabric Adhesive Bandages, 1" x 3", Pkg/16
FA4006	Triangular Bandage, 40" x 40" x 56"
FA7002	Sterile Eye Pads & Adhesive Strips, Pkg/4
FA181200	Burn Jel, Pkg/6
FA182224	CPR Pack: "CPRotector" & Gloves
FA21004	Instant Cold Pack, 4" x 5"
FA1012	Butterfly Closures, Large, Pkg/16
FAB204	Conforming Gauze, 2" x 4 yd, Pkg/2
FA3005	Gauze Compress, 24" x 72"
FA12011	Alcohol Wipes, Pkg/10
FA12018	BZK Antiseptic Towelettes, Pkg/10
FA10004	PVP Iodine Swabs, Pkg/10
FA9001	Ammonia Inhalants, Pkg/10
FA19002	Sting Relief Wipes, Pkg/10
FA21003	Flexible Wire Splint, 3 ³ / ₄ " x 27"



NIPFT104

MISCELLANEOUS FIRST AID

These powder-free **DISPOSABLE NITRILE GLOVES**, from **MCR**, are perfect for people who have latex allergies. Super strong with a secure fit, they provide tactile sensitivity plus chemical protection. Textured surface (4 mil). Blue. Pkg/100.

P/N	DESCRIPTION	SIZE
NIPFT102	Disposable Nitrile Gloves	SM
NIPFT103	Disposable Nitrile Gloves	MD
NIPFT104	Disposable Nitrile Gloves	LG
NIPFT105	Disposable Nitrile Gloves	XL



P104

Get dependable, quality hand protection at an affordable price with **MCR DISPOSABLE LATEX GLOVES**. They are powdered with a smooth finish, and come standard with rolled cuffs (5 mil). FDA compliant. Natural. Pkg/100.

P/N	DESCRIPTION	SIZE
P103	Disposable Latex Gloves	MD
P104	Disposable Latex Gloves	LG
P105	Disposable Latex Gloves	XL



FA235072

These **NITRILE FINGER COTS** are ideal for food service work. Pkg/144.

P/N	DESCRIPTION	SIZE
FA235072	Nitrile Finger Cots	MD
FA235075	Nitrile Finger Cots	LG

Specially formulated with moisturizers to leave hands soft without a sticky residue, **Purell® HAND SANITIZERS** are America's #1 instant hand sanitizer. They feature a complete and innovative product line that includes individually wrapped wipes and gel. Alcohol based, they work in seconds to kill 99.99% of most common germs that cause illness.

P/N	DESCRIPTION
FA34400	Sanitizing Wipes, Individually Wrapped, Pkg/100
FA34410	Sanitizing Wipes, Canister/175
HANDSAN8	Hand Sanitizer, 8 oz Pump Bottle



FA34400



FA34410

Ready-to-install, this **Purell ES™ EVERYWHERE SYSTEM STARTER KIT** comes complete with a pre-assembled base, refill cartridge, and **Command®** strips for simple surface attachment. The refill is exposed for easy monitoring of product level and servicing.

P/N	DESCRIPTION
FA1450D8	Everywhere System Starter Kit
FA145006	450 mL Refill, Case/6 For FA1450D8



HANDSAN8



FA1450D8

ANTISEPTICS and OINTMENTS.

P/N	DESCRIPTION
FA90325	WoundSeal Blood Clot Powder w/ Applicators, Pkg/2
FAH305	Alcohol Wipes, Pkg/100
FA51028	BZK Antiseptic Towelettes, Pkg/25
FA18135	Lip Balm Packets, 0.9 g, Pkg/10
FAG460	Triple Antibiotic Ointment, 0.5 g, Pkg/25
FAG486	Hydrocortisone Cream, 0.9 g, Pkg/25
FAG343	First Aid/Burn Cream, 0.9 g, Pkg/25
→ FA90897	SaniZide Plus Germicidal Wipes, 8" x 8", Pkg/50
FA750013	Hand Sanitizer Packets, 0.9 g, Pkg/10



FA90325



FA18135



FAG460

BUG REMEDIES

P/N	DESCRIPTION
FA213019	Insect Sting Swabs, Pkg/10
FA233033	Insect Sting Relief Spray, 2 oz



FA90897



FA213019



FAM5123

FAM530

FAM529

MEDICATED SPRAYS

P/N	DESCRIPTION
FAM5123	Alcohol Pump Spray, 4 oz
FAM5124	Hydrogen Peroxide Pump Spray, 4 oz
FA13080	Antiseptic Pump Spray, 4 oz
FA4017	Burn Pump Spray, 2 oz
FA4016	Antiseptic Pump Spray, 2 oz
FAM530	Cold Spray, 4 oz
FAM529	Blood Clotter Spray, 3 oz



FA21004

FA13463

FA4032

HOT/COLD PACKS

P/N	DESCRIPTION
FA21004	Instant Cold Pack, 4" x 5"
FA4032	Instant Cold Pack, Large
FA234014	Instant Hot Pack
FA13463	Reusable Hot/Cold Pack, 4" x 6"



FA22410

FA90893

FIRST AID INSTRUMENTS

P/N	DESCRIPTION
FAM582	Scissors, 4 1/2"
FA5054	Dumont Splinter Tweezers, 5" w/ Case
FA17020	Plastic Forceps, 3 1/2"
FAM585	Stainless Steel Tweezers, 3 1/2"
→ FA22410	Splinter Out, Pkg/10
FA5053	Eye Magnet & Loop w/ Case
FA21770	Disposable Thermometers, Pkg/10
FA262020	Disposable Penlight
FA90874	Digital Thermometer w/ Sheath, Pkg/20
→ FA90893	Steel Forceps w/ Magnifying Glass, 5 1/2", Pkg/12



FA9926

This **Space® Brand COMPACT EMERGENCY BLANKET** utilizes space-age technology to fight off cold, rain, wind, and sun. Ideal for treating hypothermia or shock, it is made of vacuum-deposited metal with a polyester film surface. It can also reflect radar or be used as a signal mirror. Measures 84" x 56".

P/N	DESCRIPTION
FA9926	Emergency Blanket



1000ES In Use

The **PURE FLOW 1000** delivers saline solution purified, contaminant-free, and physiologically correct, from a sealed integrated delivery module. The cartridge has a 24-month shelf life, from date of manufacture. Must purchase fluid cartridges separately. Meets ANSI Z358.1 15-minute flushing requirement.

P/N	DESCRIPTION
1000ES	Eyewash Station (Empty)
1000FC	Eyewash Cartridges, Pkg/2

Eyesaline® EYEWASH PRODUCTS.

P/N	DESCRIPTION
460ES	Single 16 oz Wall Station
461ES	Single 32 oz Wall Station
462ES	Double 32 oz Wall Station
454EB	Replacement 16 oz Bottle
455EB	Replacement 32 oz Bottle



460ES

EYE CARE PRODUCTS include eye drops for quick, soothing relief from minor eye irritations; disposable eye cups for washing out particles in the eye; and **TheraTears** for exceptional relief of dry, tired, irritated eyes.

P/N	DESCRIPTION
FA24050	Eyewash, 8 oz
FAM795	Eye Cups, Vial/6
FAM796THERA	TheraTears Eye Lubricants, 0.02 oz, Pkg/32
RP176A	"Emergency Eye Wash" ANSI Z535 Sign, 7" x 10"
PTD176	"Emergency Eye Wash" 3-D Sign, 18" x 10"
EWTAG	Shower/Eyewash Inspection Tags, 3" x 5 3/4", Pkg/100



EWTAG



RP176A



PTD176

BURN RELIEF

Water-Jel® FIRE BLANKETS and **WRAPS** offer one-step solutions to emergency first aid on burn victims. **Wrap** covers a victim's limb or torso, while the **Blanket** completely covers a person (up to 6' tall). **Water-Jel Fire Blankets** are 100% worsted wool and come thoroughly saturated in an odor-free, crystal clear cooling gel, which helps with the visualization and assessment of injuries. They protect against heat and flame, put out the fire, stop burn progression, and cool the skin.

P/N	DESCRIPTION
→ FAG3630P4	Burn Wrap, 2 1/2' x 3', Pouch
→ FAG7260C4	Fire Blanket Plus, 5' x 6', Canister



→ NEW

FAG3630P4



→ NEW

FAG7260C4

BURN RELIEF

P/N	DESCRIPTION
FA6500	Burn Jel, 3.5 g, Pkg/25
FA4240B	Burn Jel (Minor Burns), 4 oz
FA181200	Burn Jel, 3.5 g, Pkg/6
FACJ25600	Cool Jel Packet, 3.5 g, Pkg/25
FA4240C	Cool Jel (Minor Burns), 4 oz



FA4240B, FA4240C

Medical-grade **Water-Jel® STERILE BURN DRESSINGS** ease pain, cool the burn, and help protect against airborne contamination.

P/N	DESCRIPTION
FA020660	Burn Dressing, 2" x 6"
FA6502	Burn Dressing, 4" x 4"
FA041628	Burn Dressing, 4" x 16"
→ FAB081820	Burn Dressing, 8" x 18"



→ NEW

FAB081820



Cover most burn situations with **Water-Jel® BURN KITS**.

Featuring sterile **Water-Jel** burn dressings, in the most popular sizes, each kit contains a host of water-based/water soluble-gel dressings that will not stick to wounds or trap heat.

P/N	DESCRIPTION
FA1600*	Emergency Soft-Sided Burn Kit, Small
FAEBK2HA	Emergency Soft-Sided Burn Kit, Large
→ FAIWKHA	Emergency Industrial Welding Burn Kit (Plastic)

KIT CONTENTS	FA1600	FAEBK2HA	FAIWKHA
Burn Dressing, 2" x 6"	-	-	2
Burn Dressing, 4" x 4"	2	3	2
Burn Dressing, 4" x 16"	2	1	1
Burn Dressing, 8" x 18"	-	1	1
Burn Dressing, 12" x 16" (Face Mask)	1	1	1
Sterile Gauze Roll, 3" x 4 yd	2	4	-
Scissors	1	1	-
Burn Wrap, 2 1/2' x 3'	-	1	-
Single Dose Burn Jel	-	-	25
Elastic Bandage	-	-	1
Instruction Card	1	1	1

*WHILE QUANTITIES LAST!



DEFIBRILLATORS

HeartSine's Samaritan® Pad AED was designed especially for use in public areas, providing a sophisticated defibrillator for adult or pediatric use inside a lightweight and easy-to-operate system.

Its battery and electrode pads are incorporated into an "all-in-one" **Pad-Pak**, sharing a single expiry date. Designed for the minimally trained rescuer, the semi-automatic **Samaritan PAD** has both visual prompts along with voice/icon prompts for easy instruction. It comes with a **Samaritan Defibrillator**, adult **Pad-Pak**, storage/carrying case, data port, quick instruction card, user manual, and CPR poster.

A Medical Authorization Form is included with sale of each unit.
NOTE: Good Samaritan laws provide limited immunity for AED owners.



PRIMARY UNIT

P/N	DESCRIPTION
HSAEDBAS	Samaritan PAD 350P w/ 1 Adult Pad-Pak

ACCESSORIES

P/N	DESCRIPTION
DDPHSAEDPAK01	Pad-Pak Adult Cartridge
DDPHSAEDPAK02	Pad-Pak Pediatric Cartridge

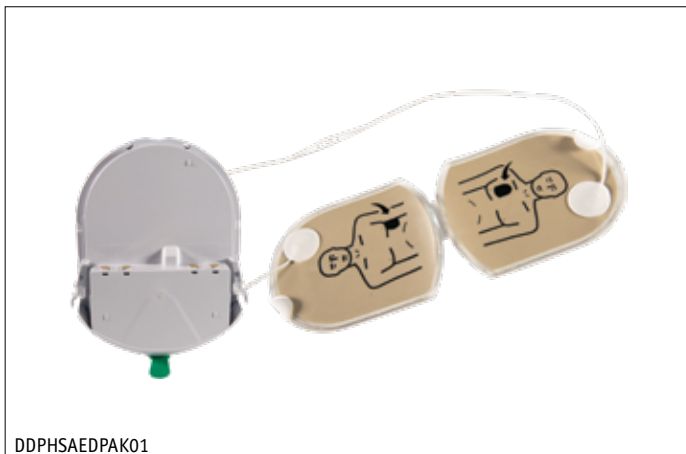

Zoll's AED PLUS® PACKAGE is easily operated by almost anyone, thanks to its **Real CPR Help®** software with audio and text prompts. There is a visual bar gauge on its screen to show the depth of each compression as it is taking place. The **AED Plus Package** lasts for five years (from the date of manufacture). Ingress protection rating is IP-55 for dust and water, meaning it is okay to place it in almost any environment. The system is powered by ten lithium batteries (included).

P/N	DESCRIPTION
ZAEDPLUSP1*	Semi Automatic AED Plus Package
ZAEDPLUSA*	Fully Automatic AED Plus Package
ZCABMW	Standard Metal Wall Cabinet
ZDPAD	CPR-D Padz Adult Electrodes
ZDL123A*	Duracell Ultra CR123A Lithium Batteries, Pkg/10
DDPZPLUSTRAC1**	PlusTrac Professional 1 yr AED Program
DDPZPLUSTRAC5**	PlusTrac Professional 5 yr AED Program
	*UNAVAILABLE IN AK, HI, PR, OR CATALINA
	**LOG ON TO BROOKSEQUIPMENT.COM FOR MORE INFORMATION ON THESE PROGRAMS



ZAEDPLUSP1



ZAEDPLUSA

AED PROTECTIVE CABINETS

JL Industries Life Start™ AED CABINETS fit most AED units on the market today. ADAC compliant, they feature solid steel construction with full-acrylic door styles, white powder-coated finishes, and 85 dB alarms. Other features include zinc-plated handles, roller catches, continuous hinges, and On/Off key switches. **NOTE:** See page 31 for complete size information.

P/N	DESCRIPTION	H X W X D
1413F12	Surface-Mount AED Cabinet	17 ³ / ₁₆ " x 17 ³ / ₁₆ " x 7"
1417F12	Semi-Recessed AED Cabinet	14" x 14" x 6 ³ / ₄ " w/ 1 ¹ / ₂ " Trim



1417F12



STI7531AED

Wall-mountable **AED PROTECTIVE CABINETS**, from **STI**, keep AED units free of dust and dirt, plus they discourage vandalism via a thumb lock. Select from three different styles: No Alarm, Stop Sign Alarm (105 dB of 95 dB warning horn), or Siren/Strobe Alarm (alarm and bright flashing LED combo). Set the alarm timing for 15 seconds, 30 seconds, 60 seconds, or continuous. Measures 12¹/₄"L x 14¹/₄"H x 6¹/₂"D.

P/N	DESCRIPTION
STI7531AED	AED Protective Cabinet, Polycarbonate w/ Backplate, Wire Shelf, & Clear Thumb Lock
DDPSTI7533AED	AED Protective Cabinet, Polycarbonate w/ Backplate, Wire Shelf, Stop Sign Siren Alarm, & Clear Thumb Lock
DDPSTI7535AED	AED Protective Cabinet, Polycarbonate w/ Backplate, Wire Shelf, Siren/Strobe Alarm, & Clear Thumb Lock



DDPSTI7533AED



DDPSTI7535AED

DEFIBRILLATOR REPLACEMENT PARTS

PHILIPS - HEARTSTART ONSITE M5066A

P/N	DESCRIPTION
FAM5071A	Adult Electrode Pads Cartridge (1 Set)
FAM5072A	Infant/Child Electrode Pads Cartridge (1 Set)
FAM5070A	HeartStart 4-Year Battery

PHILIPS - HEARTSTART FRX 861304

P/N	DESCRIPTION
FA989803139261	Smart Pads II
FAM5070A	HeartStart 4-Year Battery

OTHER ACCESSORIES

P/N	DESCRIPTION
PTD261	"Automated External Defibrillator" 3-D Sign, 5" x 6"
G261	Glow-in-the-Dark AED Label, 6" x 8"
AEDTAGBK	AED Service Tag, Pkg/100
NIPFT102	Nitrile Gloves, Small, Pkg/100
NIPFT103	Nitrile Gloves, Medium, Pkg/100
NIPFT104	Nitrile Gloves, Large, Pkg/100
NIPFT105	Nitrile Gloves, X-Large, Pkg/100



PTD261

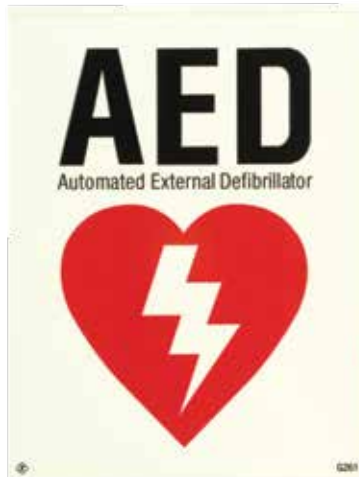

G261



NIPFT104



00

SPRINKLER ACCESSORIES & STANDPIPE EQUIPMENT



→ NEW

QU135



→ NEW

34QU155

REPLACEMENT SPRINKLER HEADS

The **Globe® QUICK RESPONSE GL SERIES**

SPRINKLERS offer a low profile, durable design with 3 mm frangible glass ampules (with alcohol) as their thermo-sensitive element. This means sprinkler operation up to six-times faster than standard sprinklers. They can also be used in place of standard sprinklers when allowed by the applicable standards. UL listed and FM approved.

P/N	DESCRIPTION
→ QP135	135°F Pendent, 1/2", 5.6 K Factor, Brass
→ QU135	135°F Upright, 1/2", 5.6 K Factor, Brass
→ QPC135	135°F Pendent, 1/2", 5.6 K Factor, Chrome
→ QP155	155°F Pendent, 1/2", 5.6 K Factor, Brass
→ QU155	155°F Upright, 1/2", 5.6 K Factor, Brass
→ QPSW155	155°F Sidewall, 1/2", 5.6 K Factor, Brass
→ QPC155	155°F Pendent, 1/2", 5.6 K Factor, Chrome
→ QPSW155C	155°F Sidewall, 1/2", 5.6 K Factor, Chrome
→ QPW155	155°F Pendent, 1/2", 5.6 K Factor, White
→ QPSW155W	155°F Sidewall, 1/2", 5.6 K Factor, White
→ QP200	200°F Pendent, 1/2", 5.6 K Factor, Brass
→ QU200	200°F Upright, 1/2", 5.6 K Factor, Brass
→ QPSW200	200°F Sidewall, 1/2", 5.6 K Factor, Brass
→ QPC200	200°F Pendent, 1/2", 5.6 K Factor, Chrome
→ QPSW200C	200°F Sidewall, 1/2", 5.6 K Factor, Chrome
→ QPW200	200°F Pendent, 1/2", 5.6 K Factor, White
→ QPSW200W	200°F Sidewall, 1/2", 5.6 K Factor, White
→ QP286	286°F Pendent, 1/2", 5.6 K Factor, Brass
→ QU286	286°F Upright, 1/2", 5.6 K Factor, Brass
→ QPSW286	286°F Sidewall, 1/2", 5.6 K Factor, Brass
→ QPSW286C	286°F Sidewall, 1/2", 5.6 K Factor, Chrome
→ QPW286	286°F Pendent, 1/2", 5.6 K Factor, White
→ 34QP155	155°F Pendent, 3/4", 8.0 K Factor, Brass
→ 34QP200	200°F Pendent, 3/4", 8.0 K Factor, Brass
→ 34QU155	155°F Upright, 3/4", 8.0 K Factor, Brass
→ 34QU200	200°F Upright, 3/4", 8.0 K Factor, Brass

Globe® GL STANDARD SERIES SPRINKLERS feature

a low-profile yet durable design, utilizing a frangible 5 mm glass ampule as the thermo-sensitive element. This actuating assembly is hermetically sealed, containing a precise amount of glycerin. When heat is absorbed, fluid expands, shattering the glass at the prescribed temperature and discharging the water in an approved pattern (depending upon deflector style.) UL listed and FM approved.



SP135



SU135



SPC155



SPW155

P/N	DESCRIPTION
SP135	135°F Pendent, 1/2", 5.6 K Factor, Brass
SU135	135°F Upright, 1/2", 5.6 K Factor, Brass
SPC135	135°F Pendent, 1/2", 5.6 K Factor, Chrome
SP155	155°F Pendent, 1/2", 5.6 K Factor, Brass
SU155	155°F Upright, 1/2", 5.6 K Factor, Brass
SPSW155	155°F Sidewall, 1/2", 5.6 K Factor, Brass
SPC155	155°F Pendent, 1/2", 5.6 K Factor, Chrome
SPSW155C	155°F Sidewall, 1/2", 5.6 K Factor, Chrome
SPW155	155°F Pendent, 1/2", 5.6 K Factor, White
SPSW155W	155°F Sidewall, 1/2", 5.6 K Factor, White
SP200	200°F Pendent, 1/2", 5.6 K Factor, Brass
SU200	200°F Upright, 1/2", 5.6 K Factor, Brass
SPSW200	200°F Sidewall, 1/2", 5.6 K Factor, Brass
SPC200	200°F Pendent, 1/2", 5.6 K Factor, Chrome
SPSW200C	200°F Sidewall, 1/2", 5.6 K Factor, Chrome
SPW200	200°F Pendent, 1/2", 5.6 K Factor, White
SPSW200W	200°F Sidewall, 1/2", 5.6 K Factor, White
SP286	286°F Pendent, 1/2", 5.6 K Factor, Brass
SU286	286°F Upright, 1/2", 5.6 K Factor, Brass
SPSW286	286°F Sidewall, 1/2", 5.6 K Factor, Brass
SPSW286C	286°F Sidewall, 1/2", 5.6 K Factor, Chrome
SPW286	286°F Pendent, 1/2", 5.6 K Factor, White
34SP155	155°F Pendent, 3/4", 8.0 K Factor, Brass
34SP200	200°F Pendent, 3/4", 8.0 K Factor, Brass
34SU155	155°F Upright, 3/4", 8.0 K Factor, Brass
34SU200	200°F Upright, 3/4", 8.0 K Factor, Brass



SPSW155, SPSW155C, SPSW155W

SPRINKLER SPECIALTIES

For an extra measure of protection, use **SPRINKLER CAGES** in areas where sprinklers are exposed and susceptible to damage. These tough metal cages are available in either one- or two-piece construction and in your choice of red or chrome. Fits most 1/2" or 3/4" sprinkler heads.

P/N	DESCRIPTION
SPC660	1-Piece Cage, 1/2", Red
SPC670	1-Piece Cage, 1/2", Chrome
SPC675	2-Piece Cage, 1/2", Red
SPC685	2-Piece Cage, 1/2", Chrome
SPC680	2-Piece Cage, 3/4", Red
SPC690	1-Piece Cage w/ Shield, 1/2" & 3/4", Red
SPC692	1-Piece "Mini" Cage, 1/2" & 3/4", Chrome

We offer two sizes of **SPRINKLER HEAD CABINETS** to help you meet code requirements—6 and 12 head. Each cabinet is constructed from steel with a red enamel finish and accommodates 1/2" and 3/4" heads as well as most sprinkler wrenches. Pre-drilled for easy wall mounting. Red.

P/N	DESCRIPTION	L X H X W
SHC6	6-Head Cabinet	14" x 5" x 2 1/2"
SHC12	12-Head Cabinet	14 1/4" x 5 1/2" x 4"

Strong yet lightweight, the **FireTech™ NIPPLE TOTE BOX** holds 3/8" and 1/2" nipples (close-6") and features a fold-away handle for easy storage. Made of 18 ga steel with a red enamel finish and 77 compartments. Red.

P/N	DESCRIPTION	L X H X W
PNT1	Nipple Tote Box	10 3/8" x 6 1/2" x 7 3/8"

The **FireTech™ FITTINGS TOTE TRAY** organizes and carries a wide variety of fittings. Manufactured of 18 ga steel with a red enamel finish for superior durability, it features a fold-away handle and seven compartments. Red.

P/N	DESCRIPTION	L X H X W
PFT2	Fittings Tote Tray	15" x 5" x 10"

For Fittings and Nipples, See Section 12.

WALL ESCUTCHEONS come in **Solid** or **Split** designs. The heavy-duty **Split** version uses springs to perfectly center the escutcheon on pipe and sprinkler heads. It is also ideal for installation around existing heads. Chrome plated.

P/N	DESCRIPTION
EP700	Solid Escutcheon, 1/2" ID x 2 3/8" OD
EP200	Split Escutcheon, 1/2" ID x 2 3/8" OD
EP300	Split Escutcheon, 3/4" ID x 2 3/4" OD

These canopy-style two-piece **ESCUTCHEONS** are available with **Solid** or **Split Cups**. The **Split** version is perfect for installation around existing sprinkler heads, while the **Solid** model is used prior to head installation. Order one **Cup** and one **Skirt** for each sprinkler head. Chrome plated with 1/2" ID x 3 3/8" OD.

P/N	DESCRIPTION
EP600	Solid Escutcheon Cup
EP650	Split Escutcheon Cup
EP500	Escutcheon Skirt
	For EP600 & EP650



SPC660 In Use



SPC675 In Use



SPC690 In Use



SPC692 In Use



SHC12 In Use



PNT1 In Use

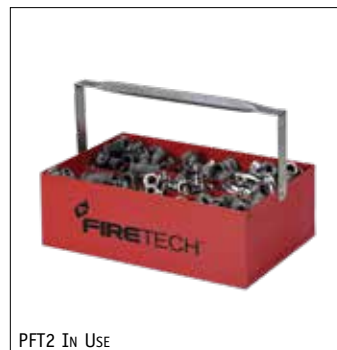

PFT2 In Use



EP700



EP200



EP600 w/ EP500 In Use



EP650



EP10 In Use

Globe® TWO-PIECE RECESSED ESCUTCHEONS are available in white or chrome and fit **Globe** 1/2" **GL** model sprinkler heads. 1/2" ID x 2 3/4" OD. UL listed and FM approved.

P/N	DESCRIPTION
EP10	Two-Piece Escutcheon, Chrome
EP20	Two-Piece Escutcheon, White



PRO250



PRO1

ProSeal PTFE PIPE THREAD SEALANT lubricates, protects, and seals threads and fittings. Ideal for stainless steel, nickel, synthetic rubbers, brass, galvanized iron, and more.

P/N	DESCRIPTION
PRO250	Thread Sealant w/ Brush, 250 mL
PRO1*	Thread Sealant, 1 L

*WHILE QUANTITIES LAST!

This **PIPE DOPE BRUSH**, with 6" wood handle and natural fibers, is a longtime favorite with pipe fitters.

P/N	DESCRIPTION
PDB	Dope Brush



PDB

Quickfit SPRINKLER SHUTOFF. Simple, quick positive shutoff is for many types of sprinkler heads (with openings of approximately 1" x 7/8" or 1 11/16" x 3/4"). It allows sprinkler heads out of the fire area to be shut off.

P/N	DESCRIPTION
SP50	Sprinkler Shutoff



SP50

SPRINKLER WRENCHES for **Globe®** sprinklers.

P/N	DESCRIPTION
RSW2	Recessed Sprinkler Wrench For 1/2" "GL" & "U" Style
SPWR2	Sprinkler Wrench For 1/2" "GL" Style
SPWR34	Sprinkler Wrench For 3/4" "GL" Style



RSW2



SPWR34



SPWR2

PTFE TAPE

P/N	DESCRIPTION
T520	PTFE, 1/2" x 520" Roll, White
T75	PTFE, 3/4" x 520" Roll, White
T520HD	Hi-Density PTFE, 1/2" x 520" Roll, Pink



T520HD, T75

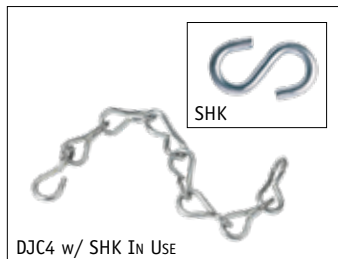

DJC4 w/ SHK In Use

DOUBLE JACK CHAIN for hanging sprinkler signs.

P/N	DESCRIPTION
DJC4	Double Jack Chain, 4"
SHK	S-Hooks, 1", Pkg/100

Perfect for mounting signs, **DOUBLE-SIDED FOAM TAPE** has numerous uses. Featuring closed-cell, cross-linked polyethylene foam construction, it utilizes a synthetic polymer-based adhesive that attaches to most smooth and irregular surfaces. 3/4" x 108' roll. **NOTE:** Apply at 50°F or higher.

P/N	DESCRIPTION
FT75108	Double-Sided Tape



FT75108

ADHESIVE-BACKED MAGNETIC STRIP makes mounting signs, breaker bars, and other metal goods a snap. **MS5100** is designed to withstand temperatures from -40°F to 160°F. Each **Magnetic Strip** comes with a peel-off liner and durable outdoor adhesive for good adherence. 3/4" x 100' roll.

P/N	DESCRIPTION
MS5100	Magnetic Tape

SPRINKLER IDENTIFICATION SIGNS

SPRINKLER IDENTIFICATION SIGNS are made of aluminum, painted white, and printed with fade-resistant red ink. Each sign has pre-drilled mounting holes for easy installation.

P/N	DESCRIPTION	L X H
A221	"Air Control" Sign	6" x 2"
A222	"Air Line" Sign	6" x 2"
A223	"Alarm Line" Sign	6" x 2"
A163	"Alarm Test" Sign	6" x 2"

SPRINKLER IDENTIFICATION SIGNS are made of aluminum, painted white, and printed with fade-resistant red ink. Each sign has pre-drilled mounting holes for easy installation.

P/N	DESCRIPTION	L X H
A224	"Anti-Freeze System" Sign	6" x 2"
A225	"Auxiliary Drain" Sign	6" x 2"

SPRINKLER IDENTIFICATION SIGNS are made of aluminum, painted red, and printed with fade-resistant white ink. Each sign has pre-drilled mounting holes for easy installation.

P/N	DESCRIPTION	L X H
A142*	"This Valve Controls..." Sign	6" x 4"
A226	"This Valve Controls..." Sign	9" x 7"

*NOT PLASTIC COATED

SPRINKLER IDENTIFICATION SIGNS are made of aluminum, painted white, and printed with fade-resistant red ink. Each sign has pre-drilled mounting holes for easy installation.

P/N	DESCRIPTION	L X H
A143	"Control Valve" Sign	6" x 2"
A227	"Drain" Sign	6" x 2"
A228	"Drain Valve" Sign	6" x 2"
A229	"Dry Standpipe" Sign	6" x 2"

SPRINKLER IDENTIFICATION SIGNS are made of aluminum, painted white, and printed with fade-resistant red ink. Each sign has pre-drilled mounting holes for easy installation.

P/N	DESCRIPTION	L X H
A160	"Inspection Test" Sign	6" x 2"
A243	"Fire Sprinkler Valve" Sign	6" x 2"

SPRINKLER IDENTIFICATION SIGNS are made of aluminum, painted white or red, and printed with fade-resistant white or red ink. Each sign has pre-drilled mounting holes for easy installation.

P/N	DESCRIPTION	L X H
A164*	"Hydraulic Data..." Sign	6" x 4"
A232	"Hydraulic System..." Sign	5" x 7"

*NOT PLASTIC COATED

NOTE: Signs are shipped with removable plastic film.

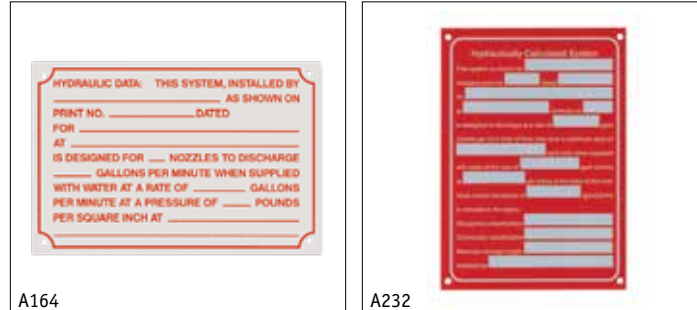
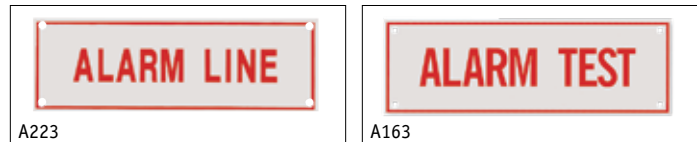



A233



A161



A235



A236



A162



A165

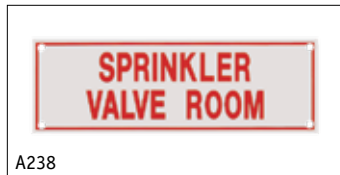

A238



A239



A242



RP251



BL252L



A245



A244



RA246

SPRINKLER IDENTIFICATION SIGNS are made of aluminum, painted white, and printed with fade-resistant red ink. Each sign has pre-drilled mounting holes for easy installation.

P/N	DESCRIPTION	L X H
A233	"Main Control" Sign	6" x 2"
A161	"Main Drain" Sign	6" x 2"
A234	"Normally Closed" Sign	6" x 2"
A235	"Normally Open" Sign	6" x 2"
A236	"Open Sprinkler Control" Sign	6" x 2"
A237	"Open Sprinkler Drain" Sign	6" x 2"
A162	"Sprinkler Control" Sign	6" x 2"

SPRINKLER IDENTIFICATION SIGNS are made of aluminum, painted white, and printed with fade-resistant red ink. Each sign has pre-drilled mounting holes for easy installation.

P/N	DESCRIPTION	L X H
A165*	"Sprinkler Fire-Alarm..." Sign	7 ³ / ₄ " x 6"
A238	"Sprinkler Valve Room" Sign	6" x 2"
A239	"Test & Drain" Sign	6" x 2"
A240	"Test Valve" Sign	6" x 2"
A241	"Water Motor Line" Sign	6" x 2"
A242	"Wet Standpipe" Sign	6" x 2"

*NOT PLASTIC COATED

SPRINKLER ALARM SIGN is made of plastic, painted red and printed with fade-resistant white ink. The sign has a pre-drilled mounting hole for easy installation over an alarm bell.

P/N	DESCRIPTION	DIA
RP251	"Sprinkler Fire Alarm ..." Sign	7"

FIRE SPRINKLER LINE LABELS are printed with fade-resistant red ink on white self-adhesive vinyl. Use them to identify sprinkler lines and direction of water flow. Roll/50.

P/N	DESCRIPTION
BL252L	"Fire Sprinkler Line" Label w/ Left Arrow
BL252R	"Fire Sprinkler Line" Label w/ Right Arrow

These quality-made **FDC SIGNS** help firefighters find water sources quickly. They are made of aluminum with pre-drilled holes for easy mounting.

P/N	DESCRIPTION
A244	"Fire Department Connection" Sign, 4" x 6"
A245	"FDC" Sign w/ Arrow, 12" x 10", 4" Letters
A246	"FDC" Sign, 10" x 14", 6" Letters
RA246	"FDC" Sign, 7" x 14", 6" Reflective Letters

Metal or Plastic Backed

Designed for wet or dry sprinkler systems, **FireTech™** **SPRINKLER GAUGES** are manufactured to exact standards, from only the finest materials, for maximum performance year in and year out. UL listed and FM approved.

Metal-backed **GAUGES**.

P/N	DESCRIPTION
MSG1	4" Air Gauge, 0–80 psi (Water Retard to 250 psi)
MSG2	4" Water Gauge, 0–300 psi
MSG3	4" Air/Water Gauge, 0–300 psi

Plastic-backed **GAUGES**.

P/N	DESCRIPTION
SG1	3 1/2" Air Gauge, 0–80 psi (Water Retard to 250 psi)
SG2	3 1/2" Water Gauge, 0–300 psi
SG3	3 1/2" Air/Water Gauge, 0–300 psi

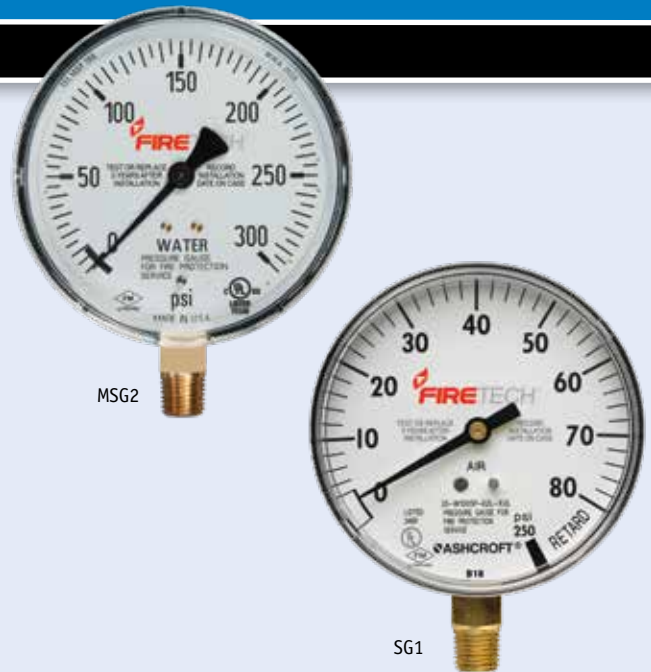

Customize Your Gauge Order with Your Name and Phone Number! Call your Account Manager at 800.826.3473 for more information.

SPRINKLER GAUGES, LABELING, AND VALVES

SPRINKLER GAUGE INSTALLATION LABELS help your customers comply with the AHJ by showing that sprinkler gauges have been tested/replaced within five years (per NFPA 25). They include spaces to record the installation date (different from the manufacturer date) and the date to test/replace the gauge. Roll/300.

P/N	DESCRIPTION
SGIL	Sprinkler Gauge Labels



SGIL In Use

This **SPRINKLER GAUGE VALVE KIT** is perfect for sprinkler systems without 3-way valves or ones that need replacing. The **SGVK** comes with (3) 1/4" nipples (2 1/2", 4", and 6" long), (1) 1/2" x 1/4" reducing bushing, (1) brass 3-way valve, and (1) 1/4" plug, while the **TWGV25** allows gauge replacement without shutting off the water.

P/N	DESCRIPTION
SGVK	3-Way Gauge Valve Kit
SGKP_	3-Way Gauge Valve Kit w/ Plastic Gauge
SGKM_	3-Way Gauge Valve Kit w/ Metal Gauge
TWGV25	1/4" 3-Way Gauge Valve
BP47	1/2" x 1/4" Black Bushing
BP48	1/4" Black Plug
N2525	1/4" x 2 1/2" Black Pipe Nipple
N2540	1/4" x 4" Black Pipe Nipple
N2560	1/4" x 6" Black Pipe Nipple



SGVK



HDVTS18



HDVTS18

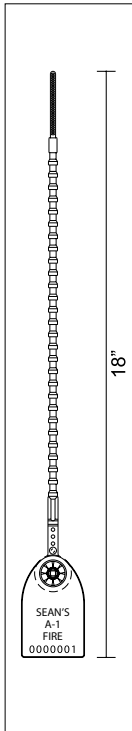

HEAVY-DUTY VALVE TAMPER SEALS are both deterrents and indicators of unauthorized opening or closing of sprinkler system valves. They meet the installation requirements of NFPA 13 and inspection requirements of NFPA 25 for sprinkler systems. (Attach seals to valves in a manner that the valves cannot be operated without breaking them.) Each seal is stamped with a 7-digit serial number that can be recorded to show who performed the installation, inspection, or maintenance. The **CUSTOM IMPRINT SEAL** is available with three lines at eight characters per line. Matted in strips of 10 for ease-of-use. Sold in boxes of 1000. (Minimum 5000.) 18".

NOTE: When seals are used, valves should be inspected weekly.

P/N	DESCRIPTION
HDVTS18	Heavy-Duty Valve Tamper Seals, Red
HDVTSBL18	Heavy-Duty Valve Tamper Seals, Blue
SSPHDVTS18	Custom Imprinted Heavy-Duty Valve Tamper Seals, Red

More Custom Imprinted Heavy Duty Valve Tamper Seals Available! Call your Account Manager at 800.826.3473 for more information.



HDVTS18 In Use

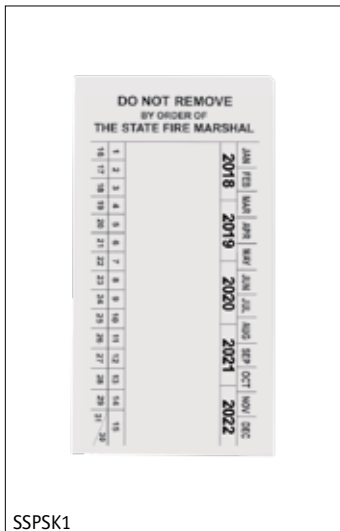

SSPSK1

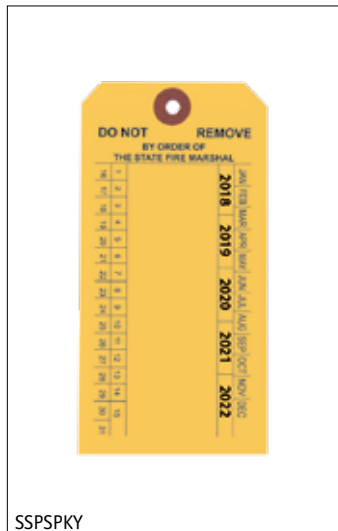

SSPSPKY

Custom-imprinted extinguisher **SPRINKLER SERVICE TAGS** are printed on both sides of coated 13-pt stock with reinforced eyelets. Final proof due every 10th and 25th of each month with delivery in 6-8 weeks. Colors available: Yellow (Y), Green (G), Red (R), and White (W). Call Sales for pricing on large orders, special designs, and our custom stocking program.

NOTE: It is the customer's responsibility to be sure the tag design meets all local and state regulations.

P/N	DESCRIPTION	L X H
SSPSPK_	Custom Sprinkler Tags (Choose Color)	5 1/4" x 2 5/8"

P/N	DESCRIPTION
SSPPL	Plate Charge (New or Updated Orders)
SSPSU	Set-Up Charge (Each Order)
SSPME	Metal Eyelets Add-On
SSPWIRE	Wire Attachment Add-On
SSP2CO	Two Ink Color Add-On
SSP3CO	Three Ink Color Add-On
SSPTVK	Tyvek Add-On, White Only (2000 Min)
SSPTVKWIRE	Tyvek Wire Attachment Add-On
SSPFLU	Fluorescent Add-On

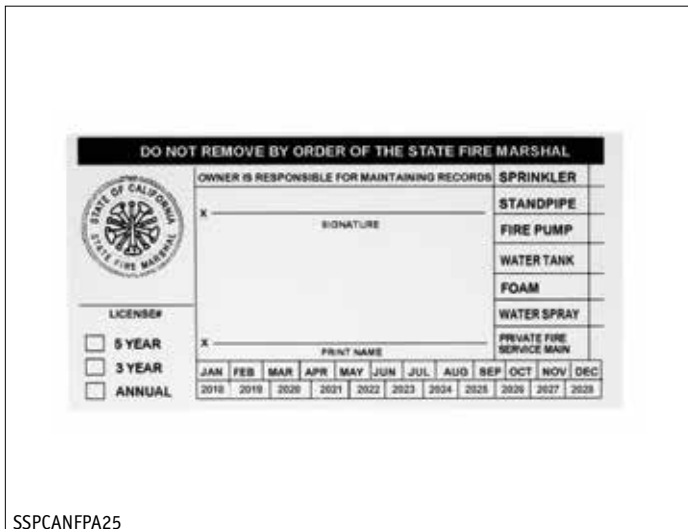

SSPCANFPA25

Custom-imprinted **SERVICE LABELS** come with your imprint in fade-resistant black ink on self-adhesive white vinyl. If you need a different design, just order part number **SSPCSTAG** and send your design to our sales staff. Labels measure 5 1/4" x 2 5/8". Sold per 1000.

P/N	DESCRIPTION
SSPCANFPA25	California NFPA 25 Sprinkler Label
SSPSK1	Custom Sprinkler Service Label, Vinyl
SSPCSTAG	Custom Service Label
SSPART	Custom Artwork

Ideal for installing the last sprinkler head on system branch lines or controlling water flow in flushing/testing situations, this **LINE TESTER** comes complete with a cap and chain. NPT threads. Cast brass.

P/N	DESCRIPTION
SLT	1" Line Tester

Solid brass **TEST & DRAIN VALVES** meet all the requirements for inspecting and testing a wet-pipe sprinkler system. Their chrome-plated ball and **PTFE** seats ensure easy operation and positive shutoff. 1/2" orifice. NPT threads. Cast brass.

P/N	DESCRIPTION
STDV1	1" Test & Drain Valve
STDV125	1 1/4" Test & Drain Valve

Commonly used in a sprinkler system at the riser, this **GLOBE ANGLE VALVE** is ideal for trim and drain applications as well as alarm valves and shotgun-type risers. Its soft seat design, utilizing **NBR** material, provides positive sealing (up to 200 psi). NPT threads. Cast brass.

P/N	DESCRIPTION
SAV200	2" Globe Angle Valve

STRAIGHT GLOBE VALVES are made with PTFE seats for improved sealing. 200 WOG. NPT threads. Cast brass.

P/N	DESCRIPTION
SGV50	1/2" Globe Straight Valve
SGV100	1" Globe Straight Valve

HOSE VALVES

Engineered for trouble-free operation, these **ANGLE HOSE VALVES** are designed for use with hose storage devices and hydrants. Each valve has a 300 lb rating and is UL listed and FM approved. Constructed of cast brass with red or silver handwheels.

P/N	DESCRIPTION
411	1 1/2" NPT(F) x 1 1/2" NPT(F) Angle Valve, Red
B411	1 1/2" NPT(F) x 1 1/2" NPT(F) Angle Valve, Silver (Domestic)
412	2 1/2" NPT(F) x 2 1/2" NPT(F) Angle Valve, Red
413	1 1/2" NPT(F) x 1 1/2" NST(M) Angle Valve, Red
414	2 1/2" NPT(F) x 2 1/2" NST(M) Angle Valve, Red
B414	2 1/2" NPT(F) x 2 1/2" NST(M) Angle Valve, Silver (Domestic)
415	1 1/2" NPT(F) x 1 1/2" NPSH(M) Angle Valve, Red

PRESSURE REDUCING ANGLE HOSE VALVES can be adjusted to restrict pressures up to 175 lb and come with locking pin devices that restrict full opening by untrained personnel. Pin may be removed by fire personnel for unrestricted operation in emergencies. UL listed. Cast brass construction with red handwheels.

P/N	DESCRIPTION
421	1 1/2" NPT(F) x 1 1/2" NPT(F) PR Valve
422	2 1/2" NPT(F) x 2 1/2" NPT(F) PR Valve
423	1 1/2" NPT(F) x 1 1/2" NST(M) PR Valve
424	2 1/2" NPT(F) x 2 1/2" NST(M) PR Valve





433



434



443



B443



REPLACEMENT PARTS



613



624

Heavy-duty **GATE VALVES** are designed for use on pump test headers and dry systems as a fire hose connection. Valves feature straightway patterns and come with caps and chains. Other features include solid wedge discs with tapered seats and 300 lb ratings. UL listed and FM approved. Cast brass construction with red handwheels.

P/N	DESCRIPTION
433	2 1/2" NPT(F) x 2 1/2" NST(M) Gate Valve
434	3" NPT(F) x 2 1/2" NST(M) Gate Valve

This **SINGLE HYDRANT GATE VALVE** is used on a fire hydrant outlet for slow and precise control of flow (throttling). Solid brass valve features a metal-to-metal seat and non-rising stem with a red handwheel. It comes standard in a straightway pattern and with a 300 lb rating.

P/N	DESCRIPTION
443	2 1/2" NST(F) x 2 1/2" NST(M) Gate Valve w/ Swivel
B443	2 1/2" NST(F) x 2 1/2" NST(M) Gate Valve w/ Swivel (Domestic)

VALVE REPLACEMENT PARTS. Red handwheels fit **Giacomini** valves; silver handwheels fit **Powhatan**.

P/N	DESCRIPTION
PHW15	Handwheel For Powhatan 1 1/2" Valve
PHWN15	Handwheel Nut For Powhatan 1 1/2" Valve
GHW15	Handwheel For Giacomini 1 1/2" Valve
PHW25	Handwheel For Powhatan 1 1/2" Valve
PHWN25	Handwheel Nut For Powhatan 1 1/2" Valve
GHW25	Handwheel For Giacomini 2 1/2" Valve
GHWN	Handwheel Nut For Giacomini Valve
GSRS15	Rubber Seal For Giacomini 1 1/2" Angle Valve
PSRS15	Rubber Seal For Powhatan 1 1/2" Angle Valve
PSRS25	Rubber Seal For Powhatan 2 1/2" Angle Valve

FIRE DEPARTMENT CONNECTIONS

This quality line of **STRAIGHT DOUBLE CLAPPER SIAMESE** is designed to help fire departments augment a building's water supply, typically at a structure's wall. Each connection comes with two 2 1/2" NST inlets and one 4" NPT outlet as well as twin female swivels. Capacity: 500 gpm. UL listed and FM approved. Cast brass.

P/N	DESCRIPTION
613	"Auto Spkr" Straight Dbl Clapper Siamese
613PCD	"Auto Spkr" Straight Dbl Clapper Siamese, Polished Chrome
623	"Standpipe" Straight Dbl Clapper Siamese

90° DOUBLE CLAPPER SIAMESE are designed to assist fire departments in supplementing existing water supplies and feature two 2 1/2" NST inlets and one 4" NPT outlet for a total capacity of 500 gpm. Siamese come standard with dual female swivels. UL listed and FM approved. Cast brass.

P/N	DESCRIPTION
614	"Auto Spkr" 90° Dbl Clapper Siamese
624	"Standpipe" 90° Dbl Clapper Siamese

An economical choice in a wall-mountable fire department connection, this **STRAIGHT SINGLE CLAPPER SIAMESE** features one clapper that swings back and forth, saving material and manufacturing costs. It comes with (2) 2½" NST inlets, (1) 4" NPT outlet, and (2) female swivels. Capacity: 500 gpm. UL listed and FM approved. Cast brass.

P/N	DESCRIPTION
612	"Auto Spkr" Straight Single Clapper Siamese



612

Another economical choice, but in a free-standing fire department connection, this **90° SINGLE CLAPPER SIAMESE** utilizes one "swing" clapper. It features (2) 2½" NST female swivels inlets and (1) 4" NPT female outlet. Capacity: 500 gpm. UL listed and FM approved. Cast brass.

P/N	DESCRIPTION
622	"Auto Spkr" 90° Single Clapper Siamese



622

Designed for use behind a wall, this **STRAIGHT CONCEALED SIAMESE** comes with (2) 2½" female NPT inlets and (1) 4" female NPT outlet. Double drop clappers offer single inlet use. Capacity: 500 gpm. UL listed. Cast brass.

P/N	DESCRIPTION
641	Straight Concealed Siamese



641

Our **STRAIGHT HYDRANT** is an excellent choice where an auxiliary water supply is needed for the fire department (typically on the roof of a building). Unit comes with (2) 2½" male NPT outlets and (1) 4" female NPT inlet. Capacity: 500 gpm. Cast brass.

NOTE: Use Angle Hose Valves to control water supply (see page 117).

P/N	DESCRIPTION
633	Straight Hydrant



633

Our **90° HYDRANT** is another excellent choice for providing auxiliary water supplies to the fire department (typically on the roof of a building). Unit features (2) 2½" male NPT outlets and (1) 4" female NPT inlet. Capacity: 500 gpm. Cast brass.

NOTE: Use Gate Valves to control water supply (see page 118).

P/N	DESCRIPTION
634	90° Hydrant



634

Designed so fire departments can supplement water supplies in residential sprinkler systems, this **SINGLE INLET CONNECTION** comes with everything you need to make the connection—(1) 1½" male NST inlet, (1) 1½" female NPT outlet, and (1) cap and chain. Cast brass.

P/N	DESCRIPTION
685	Single Inlet



685



FDC507

AUTO-SPRINKLER/STANDPIPE ESCUTCHEONS

Our selection of 4" Fire Department Connection (FDC) **RED ROUND WALL ESCUTCHEONS** is made of durable aluminum or plastic.

P/N	DESCRIPTION
FDC507	"Auto Spkr" Red Round Escutcheon, Plastic
FDC508	"Auto Spkr" Red Round Escutcheon, Aluminum



841

High-quality **ROUND WALL ESCUTCHEONS** identify and trim fire department connections seamlessly. Cast brass.

P/N	DESCRIPTION
841	"Auto Spkr" Round Escutcheon, 2 1/2"
661	"Auto Spkr" Round Escutcheon, 4"
661PCD	"Auto Spkr" Round Escutcheon, 4", Polished Chrome



661



667

RECTANGULAR WALL ESCUTCHEONS feature dual 2 1/2" openings that are 7" on center, making them ideal for most flush wall siamese. Measures 9" x 15". Cast brass.

P/N	DESCRIPTION
667	"Auto Spkr" Rectangular Escutcheon, Polished
667PCD	"Auto Spkr" Rectangular Escutcheon, Polished Chrome
668PCD	"Standpipe" Rectangular Escutcheon, Polished Chrome



FDC509

SPRINKLER ACCESSORIES

Our Fire Department **IDENTIFICATION PLATE** is made of durable red aluminum with "FIRE DEPT. CONN." in raised lettering. Measures 3 7/8" x 7 7/8".

P/N	DESCRIPTION
FDC509	"Fire Dept. Conn." ID Plate

AUTOMATIC STRAIGHT BALL DRIP VALVES keep water out of standpipe and sprinkler connections. Cast brass.

P/N	DESCRIPTION
471	1/2" Ball Drip
472	3/4" Ball Drip



471



BV75

These **FULL-PORT 1/4-TURN BALL VALVES** come with a chrome-plated ball and PTFE seats, so they open easy and close tight. UL listed and FM approved. NPT. Cast brass.

P/N	DESCRIPTION
BV75	3/4" Ball Valve
BV100	1" Ball Valve
BV150	1 1/2" Ball Valve

BRASS CAPS & CHAINS are used on fire department connections, hydrants, valves, etc., to hold back water. Pin lug design in cast, polished, or chrome-plated brass.

P/N	DESCRIPTION
511I	1½" NPSH Cap, Cast
511N	1½" NST Cap, Cast
511NPB	1½" NST Cap, Polished
511NPC	1½" NST Cap, Chrome
512N	2½" NST Cap, Cast
B512N	2½" NST Cap, Cast (Domestic)
512NPB	2½" NST Cap, Polished
512NPC	2½" NST Cap, Chrome
512NPCRL	2½" NST Cap, Chrome, Rocker Lug



511N

BRASS PLUGS & CHAINS are used on fire department inlet connections to keep inlet ports free of debris. Pin lug design in cast, polished, or chrome-plated brass.

P/N	DESCRIPTION
513N	2½" NST Plug, Cast
513NPB	2½" NST Plug, Polished
513NPC	2½" NST Plug, Chrome
513NPCRL	2½" NST Plug, Chrome, Rocker Lug
514N	1½" NST Plug, Cast



513N, 514N

PLASTIC CAPS & CHAINS are an inexpensive way to protect hydrant threads and a viable replacement for brass caps when theft is an issue. Models **B150** and **B250** thread on, while the **U250** pushes/pulls on and off. Red.

P/N	DESCRIPTION
B150IPT	1½" NPSH Plastic Cap
B150NST	1½" NST Plastic Cap
B250	2½" NST Plastic Cap
U250	2½" Universal Plastic Cap
B250G	Gasket For B250

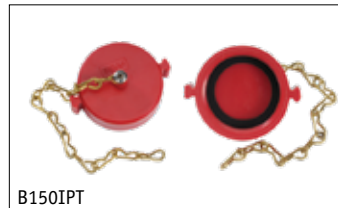

B150IPT



U250

Our **ALUMINUM BREAK CAPS** serve the same function as the brass and plastic caps, but instead of screwing or pushing/pulling on and off, they are easily broken with a hydrant/spanner wrench. Caps attach to inlets courtesy of two eye bolts that slip over pin lugs. Pkg/2.

P/N	DESCRIPTION
ABCA	Break Caps, Silver
ABCR	Break Caps, Red

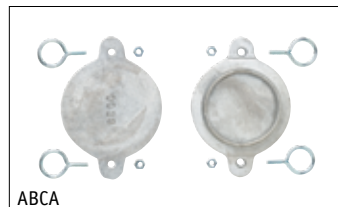

ABCA

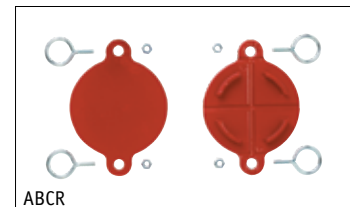

ABCR

The most economical way to protect FDC inlets is with **PLASTIC BREAK CAPS**. Choose either the **PAC**, which uses an adjustable bar that threads onto any hose thread, or the **PBC2**, which uses eye bolts to secure the cap via the inlet's pin lugs. Both fit 2½" inlets and are easily broken with a hydrant/spanner wrench. Red.

P/N	DESCRIPTION
PAC	Adjust-A-Plug
PBC2	Plastic Break Cap w/ Eye Bolts, Pkg/2



ABCR In Use



PAC



PBC2

Approved Indoor/Outdoor Notification



AB6

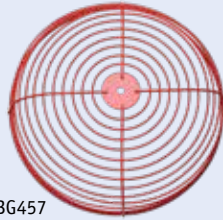

BG457



P2RHK120

System Sensor® ALARM BELLS are designed as low-current, high-decibel notification appliances for use in fire, burglary, and sprinkler systems or other signaling applications. They are simple to install and are approved for indoor or outdoor use. UL listed and FM approved. Red.

P/N	DESCRIPTION
AB6	6" Alarm Bell, 120 VAC
AB624	6" Alarm Bell, 24 VDC
AB8	8" Alarm Bell, 120 VAC
AB824	8" Alarm Bell, 24 VDC
AB10	10" Alarm Bell, 120 VAC
AB1024	10" Alarm Bell, 24 VDC
BG457	Wire Guard For 6", 8", or 10" Bells
P2RHK120	120 VAC Outdoor Horn/Strobe w/ Box
ABBB	Weatherproof Backbox For Alarm Bells



EPS402



PSP1

System Sensor® ALARM PRESSURE SWITCHES come with sensitivity adjustment wheels, reinforced diaphragms that resist pressure spikes, and dual conduit entrances. The **EPS102** is designed for use in wet, dry, deluge, and pre-action automatic sprinkler systems, while the **EPS402** is for use in dry pipe systems or pressure tanks and water pressure supplies of automatic water control valves. Both include two SPDT switches. Red.

P/N	DESCRIPTION
EPS102	Pressure Switch, 4–20 psi
EPS402	Pressure Switch, 10–100 psi



TS



PIBV2

System Sensor® electric SUPERVISORY SWITCHES are used to monitor the open position of PIB, OS&Y, and other type valves. Each features tamper-resistant NEMA 3R-rated enclosures (**PSP1** is NEMA 3 rated). UL listed and FM approved. Red.

P/N	DESCRIPTION
PIBV2	Supervisory Switch Post Indicator/Butterfly Valve
TS	Supervisory Switch OS&Y/Pressure Reducing Valve
PSP1	Supervisory Switch Non-Rising Stem Gate Valves/ Ball Valves/Angle Valves



WFD20N

System Sensor® WFDN Series WATERFLOW DETECTORS are compatible with schedule 10–40 steel pipe (2"–8") and can be mounted in a vertical or horizontal position. Each detector features a sealed retard, visual switch activation, and a computer-designed paddle for optimum performance. UL listed and FM approved. NEMA 4 Rated. Red.

P/N	DESCRIPTION
WFDTN	1" T-Tap Waterflow Detector
WFD20N	2" Waterflow Detector
WFD25N	2½" Waterflow Detector
WFD30N	3" Waterflow Detector
WFD40N	4" Waterflow Detector
WFD50N	5" Waterflow Detector
WFD60N	6" Waterflow Detector
WFD80N	8" Waterflow Detector



BROOKS
EQUIPMENT



FIRE ALARM PRODUCTS



MS4F

FIRE ALARM CONTROL PANELS – CONVENTIONAL

Fire-Lite's **MS2F** and **MS4F CONVENTIONAL FIRE ALARM CONTROL PANELS** bring the latest in microprocessor technology to conventional fire controls. They are compatible with the **i3™** smoke detectors, from **System Sensor** (see page 132), which provide advanced features such as drift compensation, maintenance alert, and freeze warning. Automatic synchronization of audio/visual devices is provided using **System Sensor®, Wheelock,** or **Gentex** protocols.

P/N	DESCRIPTION
MS2F	FACP, 2-Zone, Style B, 24 VDC, 1 Style Y NAC
MS4F	FACP, 4-Zone, Style B, 24 VDC, 2 Style Y NAC



FX5R



FX10R

The **Kidde FX CONVENTIONAL FIRE ALARM CONTROL PANEL** family consists of 5 and 10-zone units designed to simplify installation, operation, and maintenance. This includes front panel programming, one-person walk testing, and selectable **IDC** and **NAC** types. When used with **CleanMe®**-compatible conventional smoke detectors, **Kidde FX** provides intelligent-type features, such as remote maintenance alert and automatic drift compensation, reducing false alarms and maintenance calls.

P/N	DESCRIPTION
FX5R	FACP, 5 Zone, 2 NACs
FX5RD	FACP, 5 Zone w/ UD Dialer, 2 NACs
FX10R	FACP, 10 Zone, 2 NACs
FX10RD	FACP, 10 Zone w/ UD Dialer, 2 NACs



ANN80F, MS5UDF, MS10UDF

Smaller facilities, like banks, grocery stores, restaurants, strip malls, etc., can benefit from **Fire-Lite's 5-ZONE and 10-ZONE CONVENTIONAL FIRE ALARM CONTROL PANELS**, which bring the latest technology to conventional panels. Built-in keypads, with 80-character LCD displays, make them fully programmable without the need for external programmers. There are built-in **Digital Alarm Communicator Transmitters (DACT)**, which are compatible with **System Sensor® i3™** smoke detectors, providing advanced features, like drift compensation, maintenance alert, and freeze warning. Their **Notification Appliance Circuit (NAC)** synchronization protocols have the ability to silence audible alarms, while their strobes continue to flash using just a single pair of wires.

P/N	DESCRIPTION
MS5UDF	FACP 5-Zone, Style B, 24 VDC, 4 Style Y NAC w/DACT
MS10UDF	FACP 10-Zone, Style B, 24 VDC, 4 Style Y NAC w/DACT
ANN80F	80-Character LCD Serial Annunciator

FIRE ALARM CONTROL PANELS – RELEASING

For commercial, industrial, and institutional buildings that require fire suppression, **Fire-Lite's RELEASING SERVICE FIRE ALARM CONTROL PANELS** (for single and dual applications) are more than up to the task. The **DDPMRP2001F** is for deluge and pre-action applications, while the **DDPMRP2002F** handles the agent releasing applications. Both panels are compatible with **System Sensor's i3™** detectors and transmit maintenance trouble signals to the **FACP** when they need cleaning. There are supervisory 'freeze' signals when the ambient temperature falls below the detectors' rating (approximately 45°F). Panels are compatible with input devices, like two-wire or four-wire smoke detectors, pull stations, waterflow devices, and tamper switches.

P/N	DESCRIPTION
DDPMRP2001F	6-Zone FACP, Deluge & Pre-Action
DDPMRP2002F	6-Zone FACP, Agent Release
ANN80F	80-Character LCD Serial Annunciator



DDPMRP2001F

FIRE ALARM CONTROL PANELS – ADDRESSABLE

The **Kidde FX INTELLIGENT ADDRESSABLE** family consists of 64-pt or 250-pt (expandable to 1000 pts) **Fire Alarm Control Panels (FACP)**. Advanced intelligent addressable technology delivers the benefits of flexible system installation, while a clean and easy-to-operate user interface makes panel operation and system maintenance quick and intuitive. With a microprocessor in each device, intelligence is distributed throughout the system so that command decisions are made instantly at the individual module, rather than bottle necking at the control panel, to speed event processing and make a more robust and reliable system—so robust, in fact, that when upgrading from a conventional panel to a **Kidde FX** intelligent system, you can usually use existing wiring—with no twisted or shielded cable required.

P/N	DESCRIPTION
FX64RD	Addr FACP w/ UD Dialer (64 pts), Red
→ FX1000	250-pt Addressable FACP (Up to 1000 pts), Red
→ FX1000D	250-pt Addressable FACP w/ UD Dialer (Up to 1000 pts), Red
FXSA232	RS232 Module
FXSADACT	Upload/Download (UD) Dialer
FXSAETH	Ethernet Interface
FXSATRIM1	Semi-Flush Trim Kit For 64-pt Addr FACP
FXSATRIM2	Semi-Flush Trim Kit For 250-pt Addr FACP



FX64RD

FX1000D

R-Series units are high-performance **REMOTE ANNUNCIATORS** that provide status indication and common controls for **Kidde FX** intelligent addressable fire alarm systems. All models include status LEDs and internal buzzers plus large, back-lit, four-by-twenty-character-per-line super twist liquid crystal displays. Red.

P/N	DESCRIPTION
FXKRLCDR	80-Character LCD Annunciator w/o Controls
FXKRLCDR	80-Character LCD Annunciator w/ Common Controls



FXKRLCDR



MS9050UDF, ANN80F

This addressable **FIRE ALARM CONTROL PANEL**, by **Fire-Lite® Alarms**, supports up to 50 addressable devices and includes a built-in **Digital Alarm Communicator/Transmitter (DACT)** in the same circuit board, making it both compact and cost effective. The **MS9050UDF** may be connected to an 80-character fire annunciator for remote annunciation and control of system functions, including **System Acknowledge, Signal Silence, Drill, and Reset**. Other features include audio/visual device synchronization using **System Sensor®, Wheelock, and Gentex** protocol.

P/N	DESCRIPTION
MS9050UDF	Addr FACP w/ DACT
ANN80F	80-Character LCD Serial Annunciator



MS9200UDLSF

As a combination, **Fire-Lite® FIRE ALARM CONTROL PANEL** and **DIGITAL ALARM COMMUNICATOR/ TRANSMITTER** are a cost-effective addressable control panel with many powerful features. It operates in **LiteSpeed™** mode, giving it a quicker response time, so panels with the maximum 198 devices can report an incident fast—under 10 seconds. Selectable strobe synchronization for **System Sensor®, Wheelock, and Gentex** devices is standard.

P/N	DESCRIPTION
MS9200UDLSF	Addr FACP w/ Built-In Communicator



MS9600LSF

Fire-Lite's MS9600LSF ADDRESSABLE FIRE ALARM CONTROL PANEL supports up to 318 addressable devices on each of two signaling line circuits (second **SLC** optional) and offers **LiteSpeed**, a patented technology that polls 10 devices at once, allowing a fully loaded panel to report an incident and activate the notification circuits in under 10 seconds (using standard twisted unshielded wire). The panel supports the low-cost **ANN-BUS**, legacy **ACS** annunciation devices for retrofit applications, and a host of other features, including built-in **NAC** synchronization. Easily installed, programmed, and maintained, the **MS9600LSF** is ideal for use in schools, assisted living facilities, office buildings, malls, etc.

P/N	DESCRIPTION
MS9600LSF	Addr FACP, 1-2 SLC (Up to 318 pts/SLC), 24 VDC
DDPSLC2LSF	SLC Expander
DDPDACTUD2F	Increases Capacity from 318 to 636 pts Optional DACT
ANN80F	For Remote Monitoring 80-Character LCD Serial Annunciator

ADDRESSABLE DETECTORS AND ACCESSORIES

Kidde FX ADDRESSABLE DETECTORS are engineered to deliver high-performance features, superb reliability, and unbeatable quality. They resist air movement caused by heating and air conditioning, making them reliable performers. Ideally suited to modern building interiors, their twist-and-lock design makes short work of installation and maintenance operations. A bright tri-color LED flashes red when the detector is in alarm, yellow for trouble, and green for normal polling, eliminating the guesswork when responding to front-panel indications.

P/N	DESCRIPTION
FXHD	Addr Heat Detector Head (Only), Fixed or Rate-of-Rise
FXPD	Addr Smoke Detector Head (Only)
FXB4U	Addr Detector Base
FXSB4U	Addr Detector Base w/ Sounder

Fire-Lite® 300 SERIES ADDRESSABLE LOW-PROFILE PLUG-IN SMOKE DETECTORS use state-of-the-art sensing chambers with communications to provide open area protection. They are used exclusively with **Fire-Lite's Addressable Fire Alarm Control Panels**, and since they are addressable, they can help emergency personnel quickly locate a fire during its early stages. They come with two LEDs on each sensor, providing a visible sensor indication. Remote LED annunciator capability is available as an optional accessory (**RA100Z**).

P/N	DESCRIPTION
SD355F	Addr Low-Profile Photo-Smoke Detector
H355F	Addr Heat Detector
DDPSD355TF	Addr Low-Profile Photo-Smoke Detector w/ Heat
DDPH355RF	Addr 135°F Heat Detector w/ Rate-of-Rise
RA100Z	Remote LED Mounts to Single-Gang Box

→ **More Fire-Lite® ADDRESSABLE DETECTORS Available - Call for Pricing**

The **Fire-Lite® D355PLF ADDRESSABLE DUCT SMOKE DETECTOR** features a pivoting housing that fits both square and rectangular footprints and mounts to round or rectangular ductwork. This unit senses smoke in the most challenging conditions—airflow speeds of 100–4000 feet per minute, temperatures of -4°F to 158°F, and humidity of 0%–95% (non-condensing). A plug-in sensor head offers false alarm immunity and simple installation, testing, and maintenance, while its cover design isolates the sensor head from the low-flow feature for simple maintenance.

P/N	DESCRIPTION
D355PLF	Addr Photo-Duct Detector
DST1	Sampling Tube 1'-2' Duct Widths
DST3	Sampling Tube 2'-4' Duct Widths
DST5	Sampling Tube 4'-8' Duct Widths
RA100Z	Remote LED Mounts to Single-Gang Box
RTS151	Remote Test Station, Alarm & Power LEDs
RTS151KEY	Remote Test Station, Alarm & Power LEDs w/ Key Reset
APA151	Remote Annunciator w/ Piezo Alarm



FXPD



SD355F



D355PLF



FXIDC1B

ADDRESSABLE MODULES AND ACCESSORIES

Kidde FX ADDRESSABLE MODULES are engineered to deliver high-performance features, superb reliability, and unbeatable quality. Input modules connect to conventional initiating devices, while output modules control notification appliances or relays. Their ground fault detection is so precise that it actually pinpoints the specific module where the wiring problem has occurred, saving hours of troubleshooting and wire tracing.

P/N	DESCRIPTION
FXIDC1A	Addr Input Module, Class A
FXIDC1B	Addr Mini-Input Module, Class B
FXIDC2B	Addr Dual-Input Module, Class B
FXIDCWS	Addr Waterflow & SUPV Module, Class B
FXISO	SLC Isolator Module
FXNAC	Addr NAC Module, Class B/A
FXRLY	Addr Relay Module, Form C



MMF300F SHOWN W/ COVER



MMF301F

Fire-Lite's 300 Series ADDRESSABLE MONITOR/CONTROL MODULES provide an interface to conventional **Initiating Device Circuits (IDC)** and **Notification Appliance Circuits (NAC)**. Modules are addressed with easy-to-use rotary code switches and are used exclusively with **Fire-Lite's Addressable Fire Alarm Control Panels**. Since these modules are addressable, they provide the flexibility to meet the requirements of most installations.

P/N	DESCRIPTION
MMF300F	Addr Monitor Module, Style B/D <i>For N.O. Contacts, w/ LED</i>
MMF301F	Addr Mini-Monitor Module, Style B <i>For N.O. Contacts, w/o LED</i>
CMF300F	Addr Control Module, Supervised, Style Z/Y NAC
CRF300F	Addr Relay Module, 2 Form-C Relays

→ **More Fire-Lite® ADDRESSABLE MODULES Available - Call for Pricing**



FX270

Kidde FX ADDRESSABLE PULL STATIONS are available in both single and double action. Single-action stations are made from die-cast metal and finished with red epoxy powder-coat paint. They feature positive pull-lever operation so that one pull on their handle breaks the rod, turning in a positive alarm. The double-action versions are contemporary-style manual stations, made from durable red **Lexan**. To initiate their alarm, lift the upper door, then pull the alarm handle.

P/N	DESCRIPTION
FX270	Addr Pull Station, Single-Action
FX278	Addr Pull Station, Dual-Action
FX270GLR	Glass Rods, Pkg/20 <i>For 270 Series</i>



BG12LXF

Fire-Lite's state-of-the-art dual-action **PULL STATION** includes an addressable interface (mounted inside) for **Fire-Lite's Addressable Fire Alarm Control Panels**. Because the **BG12LXF** is addressable, the control panel can display the exact location of the activated manual pull station, allowing fire service personnel to locate the alarm quickly. The dual-action design requires two motions to activate the station, reducing the risk of an accidental alarm.

P/N	DESCRIPTION
BG12LXF	Addr Pull Station, Dual-Action, Lexan, w/ Key Lock

The **Xtralis® VESDA® LaserFocus® DETECTOR** is a very early warning smoke detector, designed to protect small business-critical environments of less than 500 sq m (5000 sq ft). The detector works by continually drawing air through sampling holes in a pipe network. The air is filtered and passed into a detection chamber, where extremely small amounts of smoke are detected while rejecting dust and other sources of false alarms.

P/N	DESCRIPTION
VL500	LaserFocus 500



VESDA® REPLACEMENT FILTER and ASPIRATOR.

P/N	DESCRIPTION
VSP005	Dual-Stage Filter Cartridge
VSP715	Replacement Aspirator



The **Xtralis® VESDA® VIC020 MCC (MULTI-FUNCTION CONTROL CARD)** is an interface card for the range of **Xtralis VESDA VLF** smoke detectors. Installing an **MCC** into a detector provides a cost-effective solution for customers who need enhanced connectivity, fault detection, monitoring, and annunciation of alarms and faults. The principal benefit, however, is improved **FACP** connectivity. A **VLF** is fitted with two alarm relays in its standard form, but with an extra two relays, the **MCC** allows reporting of all four alarm levels on dry relay outputs.

P/N	DESCRIPTION
VIC020	Relay Expansion Card



Xtralis® POWER SUPPLIES include the **VPS100US120**, capable of providing 24V with battery backup for the **VLF500 LaserFocus®** smoke detector. Batteries not included.

P/N	DESCRIPTION
VPS100US120	Single-Zone Power Supply
VPS300US120	Multi-Zone Power Supply



Power Rite™ ALARM BATTERIES are tough, long lasting, and powerful. Measures 5¹⁵/₁₆"L x 3⁷/₈"H x 3¹¹/₁₆"W. Case/4.

P/N	DESCRIPTION
PRB1212	12V, 12 Ah



OPEN-AREA SMOKE IMAGING DETECTION (OSID), by **Xtralis**, is a new innovation in projected beam smoke detection technology. By using advanced dual wavelength projected beams and optical imaging technology, **OSID** provides a low-cost, reliable, and easy-to-install solution that overcomes typical beam detection issues, such as false alarms and alignment problems.

P/N	DESCRIPTION
DDPOSI10	OSID Imager, 7°, 24 VDC
DDPOSI45	OSID Imager, 38°, 24 VDC
DDPOSI90	OSID Imager, 80°, 24 VDC
DDPOSESP	OSID Emitter, Standard Power (Battery)
DDPOSESPW	OSID Emitter, Standard Power Wired at 24 VDC
DDPOSEHPW	OSID Emitter, High Power Wired at 24 VDC
DDPOSIDINST	OSID Installation Kit





BMPIPE120



BMELB90



RPCLG



BMCEMENT

PIPE AND ACCESSORIES

Blazemaster™ CPVC PIPE is for use with smoke sampling detector systems. It is listed to UL 1887, Fire Test of Plastic Sprinkler Pipe for Flame and Smoke Characteristics and comes imprinted with "Smoke Detector Sampling Tube - DO NOT DISTURB".

P/N	DESCRIPTION
BMPIPE120	CPVC Pipe, 3/4" x 7 1/2', Box/16
BMPIPE240*	CPVC Pipe, 3/4" x 15', Box/16
BMELB90	CPVC 90° 3/4" Elbow
BMCOUP	CPVC 3/4" Coupling
BMTEE	CPVC 3/4" Slip Tee
BMUNION	CPVC 3/4" Union
BMEC	CPVC 3/4" End Cap
BMFAMTI	3/4" F Adapter w/ Metal Thread Insert
BMFABST	3/4" F Adapter w/ Brass Starter Thread
BMMAMTI	3/4" M Adapter w/ Metal Thread Insert

*MOTOR FREIGHT ONLY!

Wiss® RATCHET PIPE CUTTERS cut up to 1 1/8" pipe.

P/N	DESCRIPTION
RPCLG	Ratchet Pipe Cutters

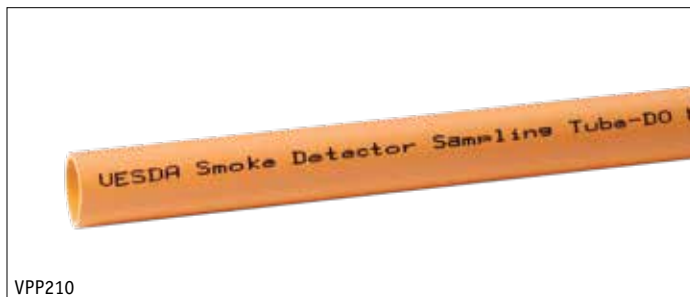

VPP210

Blazemaster™ SOLVENT CEMENT.

P/N	DESCRIPTION
BMCEMENT	CPVC Cement, 1 pt

Both the 15' and 7 1/2' lengths of 3/4" **VESDA® PIPE** are imprinted with "Smoke Detector Sampling Tube - DO NOT DISTURB" along their lengths (on opposite sides) at 18" intervals.



VPUNION



VPEC

P/N	DESCRIPTION
VPP210*	CPVC Pipe, 3/4" x 15', Box/14
VPELB90	CPVC 90° 3/4" Elbows, Box/20
VPELB901	CPVC Elbows
VPCOUP	CPVC 3/4" Couplings, Box/15
VPCOUP1	CPVC Couplings
VPUNION	CPVC 3/4" Unions, Box/10
VPUNION1	CPVC Unions
VPEC	CPVC 3/4" End Caps, Box/25
VPEC1	CPVC End Caps
VPTEE	CPVC 3/4" Slip Tees, Box/15
VPTEE1	CPVC Slip Tees

*MOTOR FREIGHT ONLY!



VPTEE



VPTEEFPT

VESDA® FPT CAPILLARY TEES.

P/N	DESCRIPTION
VPTEEFPT	CPVC 1/2" Tees, Box/10
VPTEEFPT1	CPVC 1/2" Tees, FPT Capillary



VP CUTTERS



VPCEMENT

VESDA® PIPE CUTTERS cut up to 1 1/2" pipe.

P/N	DESCRIPTION
VP CUTTERS	CPVC Cutters

VESDA® SOLVENT CEMENT.

P/N	DESCRIPTION
VPCEMENT	CPVC Cement, 1 pt

Black **POLYETHYLENE TUBING** comes in 1/2" OD x 3/8" ID and is flame retardant.

P/N	DESCRIPTION
TUBING250	Black Poly Tubing, Roll/250'
E700TUBE	Black Poly Tubing, Roll/50'
E700SP	Mini Capillary Sampling Point
PIP015	Flush Mount Sampling Point

Brooks has a convenient, pre-assembled **CONNECTOR KIT** for miniature sampling point and capillary tube arrangement. It includes one male connector (1/2" thread x 1/2" OD compression) and one female connector (1/2" OD compression).

P/N	DESCRIPTION
E700CAPKIT	Capillary Quick Connector Kit

VESDA® MINIATURE SAMPLING POINT LABELS. Gray. Sheet/12.

P/N	DESCRIPTION
E700SPLG	Capillary Point Labels

VESDA® SAMPLING POINT DECALS. Roll/200.

P/N	DESCRIPTION
E700SPDCL	Wraparound Point Decals



E700TUBE



E700SP



PIP015



E700CAPKIT



E700SPLG



E700SPDCL

With Field Replaceable Optical Chambers



FX521B

Designed for areas where typical analog/addressable devices are not suitable, the **Kidde FX521B PHOTOELECTRIC SMOKE DETECTOR** combines trusted technology and a full line of features to meet a variety of applications. Its remote maintenance, **CleanMe**, reporting and drift compensation reduce false alarms. Other features include field-replaceable optical chambers for quick and simple service and a small, low-profile design to blend into any environment.

P/N	DESCRIPTION
FX521B	Smoke, 2-Wire, Photo, 12/24 VDC



2WB

DETECTORS AND ACCESSORIES

System Sensor's i3™ Series PHOTOELECTRIC SMOKE DETECTORS are founded on three principles: installation ease, intelligence, and instant inspection. Installation ease is redefined by the simple **Stop-Drop 'N Lock** plug-in base. Intelligent features, such as **Drift Compensation** and **Maintenance Alert**, simplify testing and maintenance. Instant inspection of the detector's condition is accomplished by wide-angle red and green LED indicators.

P/N	DESCRIPTION
2WB	Smoke, 2-Wire, 12/24 VDC
2WTB	Smoke w/ Heat, 2-Wire, 12/24 VDC
4WB	Smoke, 4-Wire, 12/24 VDC
4WTB	Smoke w/ Heat, 4-Wire, 12/24 VDC
SENSRDR	i3 Smoke Detector Sensitivity Reader

→ **More SYSTEM SENSOR PRODUCTS Available - Call for Pricing.**



→ **NEW**

FX260CO

Offering commercial-grade detection technology, this **CARBON MONOXIDE ALARM**, from **Kidde**, provides quick response, reliable sensing, fast reset times, and superior false alarm immunity. Unaffected by normal variations in indoor temperatures, it automatically adjusts, operating under a wide variety of conditions. And it monitors its own performance, compensating for sensitivity drift throughout its service life. Features include **SafeTest™** for testing with real CO gas, advanced electro-chemical sensing technology, and a 10-year end-of-life signal that transmits to a central station if monitored. 85 dB alarm standard. UL 2075 compliant.

P/N	DESCRIPTION
→ FX260CO	CO Detector, 12/24 VDC



CO1224T

This **12/24 VDC CARBON MONOXIDE DETECTOR**, from **System Sensor**, provides early warning when its electrochemical sensing technology measures carbon monoxide levels in the air, sounding and flashing a temp-four 85 dB signal alarm. Plus with **RealTest™** technology, the CO gas sensing cell can be tested using a carbon monoxide gas agent. Specifically designed for system operation, the **CO1224T** is fully listed to UL 2075, offering a code-required trouble relay.

P/N	DESCRIPTION
CO1224T	System CO, 12/24 VDC

DUCT SMOKE DETECTORS AND ACCESSORIES

Less than 2" deep, **SuperDuct DUCT SMOKE DETECTORS** are ideal for installation in ductwork, where space is always at a premium. **Kidde FX SuperDuct** detectors feature a unique design that speeds installation and simplifies maintenance. And their removable dust filters, coated circuit boards, and optional water-resistant gaskets keep contaminants away from components for years of trouble-free service. When cleaning is required, assemblies come apart easily and snap back together in seconds. Their relay output may be configured for operation independent of the duct detector.

P/N	DESCRIPTION
FXSD2W	2-Wire Duct Smoke Detector
FXSD4WJ	4-Wire Duct Smoke Detector & Controller
FXSDT8	8" Duct Sampling Tube
FXSDT18	1½' Duct Sampling Tube
FXSDT24	2' Duct Sampling Tube
FXSDT36	3' Duct Sampling Tube
FXSDT42	3½' Duct Sampling Tube
FXSDT60	5' Duct Sampling Tube
FXSDT78	6½' Duct Sampling Tube
FXSDT120	10' Duct Sampling Tube
FXSDTRK4	Remote Duct Detector Test w/ Key
FXRLED	Remote LED
FXSDTRM	Remote 2-Wire Duct Detector Test (Magnetic)
FXSDTRM4	Remote 4-Wire Duct Detector Test (Magnetic)

The **System Sensor® InnovairFlex™ 4-WIRE PHOTOELECTRIC DUCT SMOKE DETECTOR** features a pivoting housing that fits both square and rectangular footprints and mounts to round or rectangular ductwork. This unit senses smoke in the most challenging conditions—airflow speeds of 100–4000 feet per minute, temperatures of -4°F to 158°F, and humidity of 0%–95% (non-condensing). A plug-in sensor head offers false alarm immunity and simple installation, testing, and maintenance, while the cover design isolates the sensor head from the low-flow feature for simple maintenance.

P/N	DESCRIPTION
D4120	Duct Smoke, Photo, 4-Wire, 24 VDC/120 VAC or 24 VDC
DST1	Sampling Tube 1'-2' Duct Widths
DST3	Sampling Tube 2'-4' Duct Widths
DST5	Sampling Tube 4'-8' Duct Widths
RA100Z	Remote LED Mounts to Single-Gang Box
RTS151	Remote Test Station, Alarm & Power LEDs
RTS151KEY	Remote Test Station, Alarm & Power LEDs w/ Key Reset
APA151	Remote Annunciator w/ Piezo Alarm



FXSD2W



D4120 SHOWN IN SQUARE CONFIGURATION



RTS151KEY



FX283BPL

HEAT DETECTORS

Kidde FX CONVENTIONAL HEAT DETECTORS provide high quality, reliability, and the ultimate in design and decor. Their low silhouette and pure-white finish blends with most ceiling styles to provide an inconspicuous installation. Detectors are available with 135°F or 194°F ratings for fixed temperature.

P/N	DESCRIPTION
FX283BPL	Heat Detector, 135°F Fixed
FX284BPL	Heat Detector, 194°F Fixed



HD5601

System Sensor® Single-circuit 5600 Series HEAT DETECTORS offer protection against fire where smoke detectors are inappropriate. Detectors easily mount to single-gang and octagonal backboxes and come with clear markings for identifying activation method and temperature rating in both Fahrenheit and Celsius.

P/N	DESCRIPTION
HD5601	5600 Heat Detector, 135°F Fixed/Rate-of-Rise
HD5602	5600 Heat Detector, 194°F Fixed/Rate-of-Rise
HD5603	5600 Heat Detector, 135°F Fixed
HD5604	5600 Heat Detector, 194°F Fixed

Thermotech HEAT DETECTORS are of the rate compensation type—normally open, self-restoring, and vertical mounting only. They are UL listed, FM approved (except for **EPM194**), and California listed for 50' x 50' areas.

NOTE: Not for use in direct sunlight. EPM194 for indoor use only. Call the Sales Department for technical support.



ET194

P/N	DESCRIPTION
EPM194	Heat Detector, Explosion Proof, 194°F
ET135	Heat Detector, All-Weather, 135°F
ET194	Heat Detector, All-Weather, 194°F

FIRE SPRINKLER MONITORING PRODUCTS

System Sensor® WFDN Series WATERFLOW DETECTORS are compatible with schedule 10–40 steel pipe, (2"–8") and can be mounted in a vertical or horizontal position. Each detector features a sealed retard, visual switch activation, and a computer-designed paddle for optimum performance. UL listed and FM approved. NEMA 4 Rated. Red.



WFD20N

P/N	DESCRIPTION
WFDTN	1" T-Tap Waterflow Detector
WFD20N	2" Waterflow Detector
WFD25N	2½" Waterflow Detector
WFD30N	3" Waterflow Detector
WFD40N	4" Waterflow Detector
WFD50N	5" Waterflow Detector
WFD60N	6" Waterflow Detector
WFD80N	8" Waterflow Detector

System Sensor® ALARM PRESSURE SWITCHES come with sensitivity adjustment wheels, reinforced diaphragms that resist pressure spikes, and dual conduit entrances. The **EPS102** is designed for use in wet, dry, deluge, and pre-action automatic sprinkler systems, while the **EPS402** is for use in dry pipe systems or pressure tanks and water pressure supplies of automatic water control valves. Both include two SPDT switches. Red.

P/N	DESCRIPTION
EPS102	Pressure Switch, 4–20 psi
EPS402	Pressure Switch, 10–100 psi

System Sensor® electric SUPERVISORY SWITCHES are used to monitor the open position of PIB, OS&Y, and other type valves. Each features tamper-resistant NEMA 3R-rated enclosures (**PSP1** is NEMA 3 rated). UL listed and FM approved. Red.

P/N	DESCRIPTION
PIBV2	Supervisory Switch For Post Indicator & Butterfly Valves
TS	Supervisory Switch For Outside Screw & Yoke (OS&Y) Gate Valves
PSP1	Supervisory Switch For Non-Rising Stem Gate Valves, Ball Valves, & Angle Valves

MANUAL PULL STATIONS AND ACCESSORIES

Kidde FX PULL STATIONS are available in both single and double action. Single-action stations are made from die-cast metal and finished with red epoxy powder-coat paint. They feature positive pull-lever operation so that one pull on their handle breaks the rod and turns in a positive alarm. The double-action version is a contemporary-style manual station made from durable red **Lexan**.

P/N	DESCRIPTION
FXK270ASPO	Pull Station, Metal, Single-Action, SPST, Leads
FXK270SPO	Pull Station, Metal, Single-Action, SPST, Terminals
FXK278B1110	Pull Station, Plastic, Double Action, SPST, Terminals
FXK278B1120	Pull Station, Plastic, Double Action, SPST, Key Reset, Terminals
FXK270GLR	Glass Rods, Pkg/20 For 270 Series

Fire-Lite's BG12 Series is a cost-effective, feature-packed, non-coded series of **MANUAL FIRE ALARM PULL STATIONS** designed to meet multiple applications with the installer and end-user in mind. The **BG12 Series** features a variety of models, including single- and dual-action versions. Innovative design, durable polycarbonate construction, and multiple mounting options make the **BG12 Series** simple to install, maintain, and operate.

P/N	DESCRIPTION
BG12F	Dual-Action, Terminal Block, Hex Key
BG12LF	Dual-Action, Terminal Block, Key Lock
BG12LOF	Dual-Action, Terminal Block, Key Lock, w/ Outdoor Rating
DDPBG12LRAF	Dual-Action Lexan, Agent Release w/ Abort Applications
SBI0F	Surface Mounting Indoor/Outdoor



EPS402



PIBV2



TS



PSP1



FXK278B1110



BG12F



BG8F

This single-action aluminum **ALARM MANUAL PULL STATION**, from **Fire-Lite**, provides, a normally open contact for fire alarm initiating when used with UL listed **Fire Alarm Control Panels (FACPs)**.

P/N	DESCRIPTION
BG8F	Pull Station, SPST
DDPBG2RF	Surface Box, Red Tapped for 1/2" Conduit

Die-cast **ALARM MANUAL PULL STATIONS** feature steel back plates and 10 A snap-action switches. Measures 4 3/4"H x 3 1/4"W x 7/8"D. Meets UL, ULC, CSEFM, and MEA requirements.

P/N	DESCRIPTION
MPS1	Pull Station, SPST Pigtail
MPS2	Pull Station, SPST w/ Terminal Block
MPS3	Pull Station, SPST w/ Terminal Block & Key
MPS4	Pull Station, DPDT
MPS5	Pull Station, DPST w/ Terminal Block
MPSBB	Surface-Mount Backbox For Pull Station
GR1	Hollow Glass Break Rod, 3" x 1/4"



MPS2

STI ALARM PULL STATION PROTECTORS are made of clear polycarbonate, with or without an 85 dB horn, and help prevent false alarms and vandalism. Fits most pull stations.

P/N	DESCRIPTION	H X W X D
STI13000NC	Protector w/o Horn	5 1/2" x 4 3/4" x 2 1/8"
STI13020FR	Protector w/ Horn	5 1/2" x 4 3/4" x 2 1/8"
STI1100	Protector w/ Horn	6 3/4" x 5 1/2" x 2 3/4"
STI1200	Protector w/o Horn	6 3/4" x 5 1/2" x 2 3/4"
STI6531*	2" Surface Conduit Spacer For STI6600 & STI6500	
STI3100	2" Surface Conduit Spacer For STI1100 & STI1200	

*WHILE QUANTITIES LAST!



STI1100 w/ MPS1 In Use

The **ALARM BREAK GLASS COVER** is made of heavy 14 ga steel. This unique design features a slot for broken glass to fall through, minimizing possible injury during use. Outside measures 7 3/8"H x 5 1/2"W x 2 1/4"D. Key lock sold separately.

P/N	DESCRIPTION
BGC	Break Glass Cover
211KL	Key Lock Assembly For BGC

REPLACEMENT BREAK RODS for alarm pull stations.

P/N	DESCRIPTION
GR1	Hollow Glass Break Rod, 3" x 1/4"
GR2	Solid Glass Break Rods, 3 1/8" x 5/32", Pkg/10 Fits Many Popular Pull Stations



BGC

Among the smallest, most compact audible/visible life-safety signaling devices on the market, these **Kidde FX Genesis Series STROBES** and **HORN STROBES** are about the size of a deck of cards. They feature cavity designs that conditions light for highly controlled distribution patterns, so no bulky specular reflectors and lenses are required. They also feature **FullLight** technology, which produces a smooth light distribution pattern without the spikes and voids characteristic of specular reflectors—so coverage area gets consistent illumination. Other features include selectable outputs—15, 30, 75, or 110 cd strobes and High (99 dB) or Low (5 dB less) horns (combo models). Pre-assembled, they fit standard 1-gang boxes (no trim plates needed) and they are controlled on a single microprocessor.

P/N	DESCRIPTION
→ FXEG1RFVM	Wall Strobe, "FIRE" Marking, 24 VDC, 15-110 Candela, Red
→ FXEG1FVM	Wall Strobe, "FIRE" Marking, 24 VDC, 15-110 Candela, White
→ FXEG1RFHDVM	Wall Horn/Strobe, "FIRE" Marking, 24 VDC, 15-110 Candela, Red
→ FXEG1FHDVM	Wall Horn/Strobe, "FIRE" Marking, 24 VDC, 15-110 Candela, White

Kidde FX TEMPORAL HORNS/STROBES are specially designed for use with **Kidde FX** fire alarm control panels and booster panels to alert occupants of a life safety event. Horns emit a piercing low-frequency sound that is easily heard above moderate ambient noise levels. The flash from their strobes can be noticed from almost any position in a room, corridor, or large open space. Red.

P/N	DESCRIPTION
FX2452THS1575R	Horn/Strobe, 24 VDC, 15/75 Candela
FX2452THS110R	Horn/Strobe, 24 VDC, 110 Candela
FX2459WPBR	2400 Series Water-Proof Box

For horns, strobes, and horn/strobes with hi-tech features, including easy installation, choose **System Sensor's SpectrAlert® ADVANCE SELECTABLE OUTPUT NOTIFICATION DEVICES**. Their plug-in design makes them simple to install—just attach the universal mounting plate to a 4" junction box, then connect the notification appliance circuit wiring to the **SEMS** terminals on the mounting plate. Finally, attach the horn, strobe, or horn/strobe to the mounting plate. The device will rotate into position and hold until it is secured with the capture mounting screw. **SpectrAlert Advance** products work on 12/24 VDC, and their horns are rated at 88+ dB. The **P2RHK120** is UL listed for outdoor use and can operate in extreme temperatures (-40°F to 151°F), in wet or dry conditions. All **SpectrAlert Advance** sensors are electrically compatible with existing **SpectrAlert** products.

P/N	DESCRIPTION
P2RHK120	120 VAC Outdoor Horn/Strobe w/ Box
→ P2RL	12/24 VDC Horn/Strobe Selectable Output
P2RK	12/24 VDC Outdoor Horn/Strobe w/ Box Selectable Output
→ SRL	12/24 VDC Strobe Only Selectable Output
HR	12/24 VDC Horn

→ **More SYSTEM SENSOR PRODUCTS Available - Call for Pricing.**



FXEG1FHDVM



FX2452THS1575R



P2RHK120



P2RL



SRL



1500 Series DOOR HOLDERS keep doors open until signaled by the fire alarm system, a heat detector, a smoke detector, or an electrical switch. They should be installed wherever doors may be effectively used to confine smoke and fire or where the release of a self-closing door, from a remote location, is required. Fail-safe operation is an inherent feature of these door holders. If power fails, doors are released automatically but may be opened or closed manually at any time. All units are free of moving parts, self-contained, and require no maintenance.

P/N	DESCRIPTION
FX15001	Door Holder Catch Plate Ext, 1 1/2"
FX15002	Door Holder Catch Plate Ext, 2 1/2"
FX15007	Adj Door Holder Catch Plate Ext, 5 1/4"-7 1/2"
FX150012	Adj Door Holder Catch Plate Ext, 7 1/2"-12"
FX1501AQN5	Door Holder, Floor Mount, 24/120 VAC
FX1504AQN5	Door Holder, Flush Mount, 24/120 VAC
FX1505AQN5	Door Holder, Semi-Flush Mount, 24/120 VAC
FX1508AQN5	Door Holder, Surface Mount, 24/120 VAC



The **DH Series FIRE DOOR HOLDERS** are made of durable die-cast metal and finished in high-luster powder-coated chrome. They have extremely low current draw that saves on power supplies and backup batteries, and installation is easy, thanks to an adhesive template that assures proper alignment without secondary adjustments. Tri-voltage (24 VDC, 24 VAC, and 120 VAC) input.

P/N	DESCRIPTION
DH24120FC	Door Holder, Semi-Flush Mount
DH24120SC	Door Holder, Surface Mount
DDPDH24120RC	Door Holder, Recessed Mount
DDPDH24120GC1	Door Holder, Ground Mount, Single Door
DHE4AC	Door Holder, 4" Adjustable Extension Rod

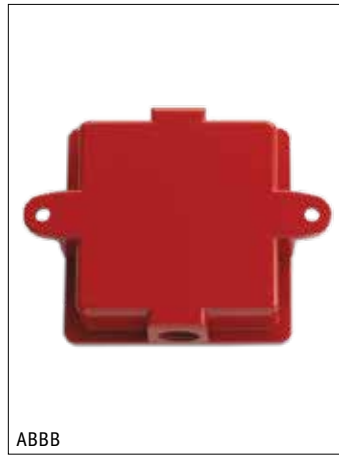

ALARM BELLS are for use in burglary, fire alarm, and sprinkler systems. Minimum 82 dB output.

P/N	DESCRIPTION
AB6	6" Alarm Bell 120 VAC
AB624	6" Alarm Bell 24 VDC
AB8	8" Alarm Bell 120 VAC
AB824	8" Alarm Bell 24 VDC
AB10	10" Alarm Bell 120 VAC
AB1024	10" Alarm Bell 24 VDC
BG457	Wire Guard
ABBB	Weatherproof Backbox For Alarm Bells

INSPECTION, TESTING, AND MAINTENANCE PRODUCTS



Solo™ 365 SMOKE DETECTOR TESTER is lighter to use, quicker to test, and suitable for more applications. It is also almost impossible to over-apply smoke, reducing the risk of detector contamination. It is cleaner, too, with on-demand smoke for less waste and a **Clearing** mode for fewer re-alarms. There are no CFC's to add to global warming either. Compatible with all smoke detectors, it is engineered for frequent use and includes an LED auto light for dark areas. Battery operated, it comes with a 3.63V lithium battery pack and USB charger connection.

P/N	DESCRIPTION
→ DDPSOL0365	Smoke & Heat Detector Test Kit
→ DDPSOLOES12	Smoke Cartridges, Pkg/12 For DDPSOL0365

Solo™ SMOKE and **HEAT DETECTOR TESTING TOOLS** offer a professional solution to NFPA 72 Inspection, Testing, and Maintenance requirements. The **SOLO808 Starter Kit** provides the equipment necessary to test smoke detectors on ceilings (up to 12'), while the **SOLO809** version increases ceiling access (up to 20'). The **DDPSOLO461 Heat Detector Testing Kit** has everything you need to successfully test heat detectors fast and easy, as does the **TRUTEST Sensitivity Tester System**, which measures the real sensitivity of smoke detectors (as required by the National Fire Code). **SOLOA4 Aerosol** uses a non-flammable, ozone-friendly, and low-residue formula to provide UL listed and manufacturer-endorsed simulated smoke. For hand-held applications, choose **CHEKKIT**, which uses the same detector-friendly formula.

P/N	DESCRIPTION
SOL0808	Starter Kit (Includes 330, 108, FTS2, & Carry Bag) For Testing up to 12'
SOL0809	Starter Kit (Includes 330, 100, FTS2, & Carry Bag) For Testing up to 20'
SOL0823	Complete Smoke & Heat Detector Testing Kit For Testing up to 30'
DDPSOL0100	15' Telescopic Access Pole
DDPSOL0610	Solo Tech Bag
DDPSOL0461	Solo Heat Detector Testing Kit For Testing Heat Detectors
TRUTEST*	Smoke Detector Sensitivity Testing System

*ACCESS POLE SOLD SEPARATELY

P/N	DESCRIPTION
SOL0A4	Smoke Detector Functional Testing Spray, 8.5 oz Aerosol
CHEKKIT	Chekkit Smoke Detector Tester, 6 oz Aerosol
SMOKE400	Aerosol, 9.5 oz Aerosol For TruTest Sensitivity Tester
SOL0C6	Solo CO Detector Functional Test Spray 150-200 Uses Per Can

→ **More SMOKE AND HEAT DETECTOR TESTING TOOLS Available - Call for Pricing.**

FireTech™ CANNED SMOKE is ideal for checking the functionality of smoke alarms in the widest possible range. It offers efficient testing in a simple-to-use format—hand-held or with use of a dispenser—and provides more tests per can with fast detector activation. Silicone-free with no CFCs and uses low GWP propellant. UL/ULC listed. 2.6 oz aerosol.

P/N	DESCRIPTION
FTS2	FireTech Smoke

SMOKESABRE is a major step forward in the design of smoke detector test aerosols. When extended, the patented design more effectively vaporizes the aerosol, providing better detector activation while using less gas per test. Plus the **Sabre** prevents the aerosol from being sprayed too close to the detector, solving the issue of residue build up that plagues other brands of canned smoke. **SmokeSabre** contains no silicone, is UL listed, and uses a bio-degradable plastic, making it both recyclable and eco-friendly. 3 oz aerosol.

P/N	DESCRIPTION
SMOKESABRE	SmokeSabre



SOLO809 In Use



TRUTEST (DDPSOL0100) In Use



SOLOA4



CHEKKIT



FTS2



SMOKESABRE

In Use photos may show items not included or available separately.



Clean Jet 100 AIR DUSTER is an ultra-filtered dust remover that produces blasts of air (up to 100 psi) with zero ozone depletion compounds. It leaves no residue and its extender tube offers pinpoint accuracy in tight spaces. Non-flammable. 10 oz aerosol.

P/N	DESCRIPTION
AB2000	Clean Jet

SMOKE ALARM TESTER is great for testing both photo-electric and ionization alarms. Environmentally friendly with 100+ bursts per can. For hard-to-reach alarms, try **DDPN30** with **DDPN59**.

NOTE: Maximum number of extensions is five (34').

P/N	DESCRIPTION
255	Smoke Alarm Tester, 2.5 oz Aerosol
TE1490	Tester Adapter w/ 18" Extension
DDPN30	30" Grip & Trigger Use w/ DDPN59
DDPN59	59" Aerosol Extension Use w/ DDPN30



Brooks' MULTI-METER measures both AC and DC current, determines continuity of lamps, and has a display-locking feature for added convenience.

P/N	DESCRIPTION
DM73C	Compact Multi-Meter



The **DBchecker™** is a **SOUND LEVEL METER** that tests audible appliances for the public operating mode of an emergency voice/alarm system. Easy to use, it conforms to ANSI S1.4 Type 2, which is required by NFPA 72. Measuring levels range from 40 dB–130 dB at frequencies between 100 Hz–8.3 kHz. Unit has one equivalent weighted sound pressure level (A) and displays with a resolution of 0.1 dB on a four-digit LCD screen. Suitable for testing new “low-frequency” notification appliances and sounders. 9V alkaline battery included.

P/N	DESCRIPTION
DB02	Sound Meter



The **DUCT DETECTOR TEST TOOL** is a battery-operated device that tests the pressure and air sampling ability of duct detectors. Testing of this type should be done once a year, as required by NFPA 72, to make sure the duct detector is sampling the airstream properly. The **Ductchecker®** comes with sampling tube plugs and a hard case to protect the tool from damage. Alkaline 9V battery included.

P/N	DESCRIPTION
DUCT01	Duct Test Tool

The **Cellchecker™ LEAD ACID PULSE LOAD BATTERY TESTER** provides a comprehensive test of a battery's state of charge and condition. With accurate pulse load testing, it tests the battery's ability to deliver current and maintain voltage under load, not just voltage or internal resistance. Its LED indicates percentages of remaining battery capacity, and it offers a fast test time (15 seconds). Battery safe (does not damage or drain the battery), it produces accurate results on new partially discharged and stored batteries and checks multiple voltages: 2, 4, 6, 8, and 12.

P/N	DESCRIPTION
CELL03	Lead Acid Pulse Load Battery Tester



CELL03

The **BACTPLUS BATTERY TESTER** features a high-impact ABS case with a rubber holster and high-contrast inverted blue screen. Designed to test the most common 6V (1.2 Ah–12 Ah) and 12V (1.2 Ah–100 Ah) lead acid batteries, it displays DC voltage and Ah capacity in seconds, and there are no confusing conversion rates to worry about. Other features include calibration control protection, reinforced input sockets, and max input voltage protection with warning LED.

P/N	DESCRIPTION
BACTPLUS	6V/12V Battery Tester



BACTPLUS In Use

Brooks' state-of-the-art **BATTERY ANALYZER** helps you perform all the necessary service on any fire alarm panel or accessory.

P/N	DESCRIPTION
BBA612	6V/12V Analyzer (Up to 24 Ah)
BBAC	Compact Carry Case For Analyzer
BBALEADS	Replacement Leads



BBA612 w/ BBALEADS

POWER SUPPLIES

This **Kidde FX REMOTE BOOSTER POWER SUPPLY** is a self-contained 24 VDC/6 A regulated power supply designed to augment fire alarm audible and visual power requirements. Its simple switch selection provides a wide variety of operational configurations, plus it has the ability to synchronize **Genesis Notification** appliances. When used with the **FXNAC** module, complete building synchronization is possible. Red.

P/N	DESCRIPTION
FXEBPS6A	NAC Power Booster w/ Genesis Synchron



FXEBPS6A



FCPS24FS6F

Fire-Lite's compact, cost-effective **REMOTE POWER SUPPLIES** connect to any 12/24 VDC **Fire Alarm Control Panel (FACP)** or they can stand alone. Primary applications include **Notification Appliance Circuit (NAC)** expansion to support ADA requirements and **NAC** synchronization or auxiliary power to support 24 VDC system accessories.

P/N	DESCRIPTION
FCPS24FS6F	Remote Power Supply/NAC Expander w/ Synch, 6 A
FCPS24FS8F	Remote Power Supply/NAC Expander w/ Synch, 8 A

→ **More FIRE-LITE PRODUCTS Available - Call for Pricing.**



FAD

Required for all new fire alarm installations, this **SYSTEM RECORD DOCUMENTS CABINET** is designed to house all code-required documents. Standard features include 16 ga steel construction with red powder coat, piano hinge, and key lock. A removable document holder and space for a can of detector test gas are standard as are key ring hooks, a business card holder, a CD case slot, and an important notes sticker for the door.

P/N	DESCRIPTION	H X W X D
FAD	Documents Box	13" x 12" x 2 1/4"

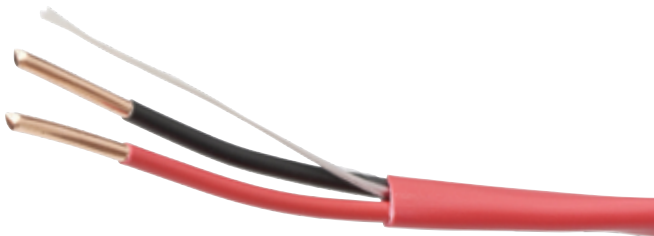

UNSHIELDED CABLE

FIRE PROTECTIVE SIGNALING CIRCUIT CABLE

Brooks' solid **FIRE ALARM CABLES** are designed for use in power-limited installations and come in either shielded or unshielded twisted pairs. **FR Series Cables** are rated NEC Type FPLR and **FP Series Cables** are rated NEC Type FPLP. 1000' spools.

TYPE FPLR

P/N	DESCRIPTION
FR182	18/2, Unshielded (FR)
FR162	16/2, Unshielded (FR)
FR182S	18/2, Shielded (FR)
FR162S	16/2, Shielded (FR)

Type FPLP

P/N	DESCRIPTION
FP182	18/2, Unshielded (FP)
FP162	16/2, Unshielded (FP)
FP182S	18/2, Shielded (FP)
FP162S	16/2, Shielded (FP)

→ **More CABLE PRODUCTS Available - Call for Pricing.**



SHIELDED CABLE

SINGLE/MULTI-STATION SMOKE ALARMS

Kidde's Worry-Free 10-YEAR PHOTOELECTRIC SMOKE ALARMS eliminate the need for battery replacement and unauthorized battery removal or deactivation for 10 years. Equipped with photoelectric sensing technology, they automatically activate when attached to their mounting brackets. **Smart Hush™**, **Alarm Memory**, **Test/Hush** buttons, and red LEDs are standard, and they chirp when they need to be replaced. Ten-year limited warranty.

P/N	DESCRIPTION
21010161*	DC Sealed Lithium Smoke Alarm w/ Voice Alarm (Photo)
21010164*	DC Sealed Lithium Smoke Alarm (Photo)
21010167*	DC Sealed Lithium Smoke Alarm w/ LED Safety Light (Photo)

*Unavailable in AK, HI, PR, or Catalina

Kidde's 914E IONIZATION SMOKE ALARM features a **Test** button, **Power-On** LED, and 85 dB alarm horn. Body measures 4" with a 4⁷/₈" mounting plate. Three-year limited warranty. 9V battery included.

P/N	DESCRIPTION
914E	DC Smoke Alarm, 4" (Ion)

Kidde's 915 IONIZATION SMOKE ALARM features a **Test** button, **Power-On** LED, and 85 dB alarm horn. Body measures 5" and is tamper resistant. Ten-year limited warranty. 9V battery included.

P/N	DESCRIPTION
915	DC Smoke Alarm, 5" (Ion)

Kidde's 918 IONIZATION SMOKE ALARM includes a **Test** button, **Power-On** LED, 85 dB alarm, and a **Safety Light** that comes on when the alarm sounds. Ten-year limited warranty. Two 9V batteries included.

P/N	DESCRIPTION
918	DC Smoke Alarm w/ Safety Light (Ion)

This **Kidde Worry-Free 10-YEAR IONIZATION SMOKE ALARM** is totally automatic and chirps when it needs replacing. Using a self-sealed lithium battery means 10 years of hassle-free operation. A **Smart Hush™** feature temporarily silences nuisance alarms, while a four-mode flashing red LED indicates **Standby**, **Smart Hush**, and **Memory Set**. Ten-year limited warranty.

P/N	DESCRIPTION
9000136*	DC Sealed Lithium Smoke Alarm w/ Smart Hush (Ion)

*Unavailable in AK, HI, PR, or Catalina

Kidde's Worry-Free 10-YEAR HARDWIRE IONIZATION SMOKE ALARM contains a sealed lithium battery backup for 10 years of continuous, trouble-free operation—even during power outages. It features two LEDs—one red for alarm mode and one green when AC power is present. Chirps when unit needs replacing.

P/N	DESCRIPTION
21010407*	AC/DC Hardwire Sealed Lithium Smoke Alarm (Ion)

*Unavailable in AK, HI, PR, or Catalina





IONIZATION/PHOTOELECTRIC SMOKE ALARMS, from **Kidde**, feature both ionization and photoelectric sensors, providing the best protection for the home. They can interconnect with up to 12 **Kidde** smoke alarms on one wiring network and come with a **Hush™** feature that temporarily silences nuisance alarms. Ten-year limited warranty. 9V batteries included.

P/N	DESCRIPTION
21007915	AC/DC Smoke Alarm (Ion/Photo)
442007	DC Smoke Alarm (Ion/Photo)



The **9120B IONIZATION SMOKE ALARM**, from **BRK**, is designed to install faster and perform better with reduced nuisance alarms. The **Relay Module** offers **Smart Interconnect** of **BRK** CO alarms. The Form-C contacts, once connected, automatically activate whenever the alarm sounds and will deactivate when the alarm shuts off. Meets UL 217, UL 2034, and UL 539 for accessories. Ten-year limited warranty. 9V battery included.

P/N	DESCRIPTION
9120B	AC/DC Smoke Alarm (Ion)
RM4	BRK Form-C Relay Module



Kidde HARDWIRE IONIZATION SMOKE ALARMS

operate as single units or interconnected with up to 12 **Kidde** smoke alarms on one wiring system. Ten-year limited warranty. 9V batteries included with AC/DC units.

P/N	DESCRIPTION
21006378	AC/DC Hardwire Smoke Alarm (Ion)
21006376	AC/DC Hardwire Smoke Alarm w/ Front-Loading Battery Door (Ion)
21006379	AC/DC Hardwire Smoke Alarm w/ Exit Light (Ion)
SM120X	Relay Power Supply Module



PHOTOELECTRIC SMOKE ALARMS, from **Kidde**, are excellent for providing early detection of smoke and fire (especially slow, smoldering fires) and come with low-battery indicators. Ten-year limited warranty. 9V batteries included.

P/N	DESCRIPTION
21006371	AC/DC Smoke Alarm (Photo)
PE9E	DC Smoke Alarm (Photo)



Kidde's HARDWIRE HEAT ALARM comes with a loud 85 dB horn that responds to temperature (135°F) rather than smoke. A **Test** button and red LED are standard, and it interconnects with other **Kidde** smoke, CO, and heat alarms. Five-year limited warranty. 9V battery included.

P/N	DESCRIPTION
HD135F	AC/DC Hardwire Heat Alarm



Kidde's COMBINATION IONIZATION SMOKE/CO ALARMS feature **Voice Identification** accompanied by an 85 dB alarm. Their voice system announces "FIRE! FIRE!" when smoke is detected and "WARNING! CARBON MONOXIDE!" when CO is detected. **Test/Reset** buttons allow testing of both smoke and CO sensors, while a warning light indicates a low-battery level on the **COSM**. The **21006377** interconnects with up to 12 units for smoke alarms and an additional six for CO alarms. Ten-year limited warranty. AA batteries included.

NOTE: The smoke alarm takes precedence when both smoke and carbon monoxide are detected.

P/N	DESCRIPTION
COSM	DC Combination Smoke/CO Alarm (Ion)
21006377	AC/DC Interconnectable, Combination Smoke/CO Alarm (Ion)
SM120X	Relay Power Supply Module



COSM

Kidde's Worry-Free 10-YEAR COMBINATION PHOTOELECTRIC SMOKE/CO ALARM eliminates the need for battery-replacement and unauthorized battery removal or deactivation. It is equipped with photoelectric and electrochemical sensing technology to detect fire and smoke as well as carbon monoxide and will automatically activate when mounted. Chirps when unit needs replacing.

P/N	DESCRIPTION
21010170*	DC Sealed Lithium Smoke/CO Combo Alarm (Photo)

*UNAVAILABLE IN AK, HI, PR, OR CATALINA



21010170

Kidde's Worry-Free 10-YEAR HARDWIRE COMBINATION IONIZATION SMOKE/CO ALARM protects against smoke, fire, and carbon monoxide. It features a voice warning that announces "Fire!" or "Warning, Carbon Monoxide" to distinguish threats. **Intelligent Sensor Technology** and **Hush** combine to reduce temporary nuisance alarms, while a 10-year lithium battery (included) provides continuous protection—even during power outages. **Peak Level Memory**, a green power LED, and a red alarm LED are standard, and it chirps when the unit needs replacing.

P/N	DESCRIPTION
21010408*	AC/DC Hardwire Sealed Lithium Combination Smoke/CO Alarm (Ion)

*UNAVAILABLE IN AK, HI, PR, OR CATALINA



21010408

Kidde's front-loading HARDWIRE CO/PHOTOELECTRIC SMOKE ALARM offers protection against both fire and carbon monoxide in a single unit. It issues audible warnings—"Fire! Fire!" or "Warning! Carbon Monoxide!", and a front-loading battery tray makes battery replacement simple. 9V battery included.

P/N	DESCRIPTION
21007624	AC/DC Hardwire Combination Smoke/CO Alarm w/ Front-Loading Battery Tray (Photo)



21007624



1279

Kidde WIRELESS IONIZATION SMOKE ALARM SYSTEMS

provide more warning, in more places, with more time to escape. Choose from 120 VAC or battery-powered alarms. Ten-year limited warranty.

P/N	DESCRIPTION
919	DC Wireless Smoke Alarm w/ 3AA Batteries (Ion)
1279	AC Wireless Smoke Alarm (Ion)

In an emergency, this **Kidde STROBE LIGHT** offers the hearing-impaired a visual cue, warning them of smoke, heat, or carbon monoxide dangers. Since these devices have no detectors, they must be used in conjunction with existing **Kidde** smoke alarms. Five-year limited warranty.

P/N	DESCRIPTION
SL177I	AC Strobe Light



SL177I

HEARING IMPAIRED PHOTOELECTRIC SMOKE

ALARMS, from **Gentex**, are ADA compliant and UL 1971. These units come equipped with three-position functional test switches with pulsing LED sensing chambers and solid-state LED condition indicators. The **7139LS** is equipped with a 9' line cord that powers up a 177 candela visual and 90 dB audible signal. The **7139CSW** is hardwired with a 9V battery backup. It has a low-battery chirp and a tandem connection for up to six detectors per system. One-year limited warranty.

NOTE: Strobe light on the 7139CSW will not function while operating on battery only.

P/N	DESCRIPTION
7139CSW	AC/DC Hardwire Hearing Impaired Smoke Alarm (Photo)
7139LS	AC/DC Hearing Impaired Smoke Alarm (Photo) w/ 9V Battery & Temporal Tone



7139CSW

CARBON MONOXIDE ALARMS

Kidde Worry-Free 10-YEAR CARBON MONOXIDE

ALARMS are self-activating when mounted to brackets and sound an 85 dB horn when dangerous levels of carbon monoxide are present. Other features include green, red, and amber LEDs. Alarms chirp when they need replacing.

P/N	DESCRIPTION
21010045*	DC Sealed Lithium CO Alarm
21010047*	DC Sealed Lithium CO Alarm w/ Digital Display

*UNAVAILABLE IN AK, HI, PR, OR CATALINA

Kidde's NightHawk™ Deluxe CARBON MONOXIDE

ALARM is a direct plug-in, wall mount, and table-top unit with a 6' cord. The Consumer Product Safety Commission recommends only alarms that meet UL standard 2034, such as the **NightHawk** carbon monoxide alarm. Five-year limited warranty. 9V battery included.

P/N	DESCRIPTION
NHDELUXE	AC/DC Direct-Plug CO Alarm



21010047



NHDELUXE

Kidde's DIRECT-PLUG-IN AC/DC CARBON

MONOXIDE ALARM continuously monitors CO levels (even when the power is out) and shows them on its digital display, since its last reset. The alarm comes standard with a **Low-Battery Hush**, **Event Memory**, and a 10-year, end-of-life warning. Once installed, the alarm maintains a vertical position, regardless of the electrical socket orientation. Ten-year limited warranty. Two AA batteries included.

P/N	DESCRIPTION
9000278	AC/DC Direct-Plug-in CO Alarm w/ Digital Display

The battery-powered **CARBON MONOXIDE ALARM**, from **Kidde**, provides early warning via a permanent electro-chemical sensor. It features red and green diagnostic lights, battery status, and sensor health. Five-year limited warranty. Two AA batteries included.

P/N	DESCRIPTION
COPB	DC CO Alarm

This **Kidde NightHawk™ COMBINATION CO/GAS**

ALARM detects CO and explosive gases, like methane or propane. It is easy to install and features a continuous digital display showing detected levels of carbon monoxide. A loud, 85 dB pulsing alarm sounds if a problem is detected. Five-year limited warranty. 9V battery included.

P/N	DESCRIPTION
9000113	AC/DC Direct-Plug-in Combination CO/Gas Alarm

SMOKE ALARM ACCESSORIES

Energizer® Ultimate Lithium® 9V BATTERY operates in all temperature extremes (-40°F to 140°F) and can last up to 10 years as a backup in AC-powered smoke detectors. Complies with ANSI 9V dimensional specs for alkaline and lithium batteries.

P/N	DESCRIPTION
L522EN*	Ultimate Lithium 9V Battery
	*UNAVAILABLE IN AK, HI, PR, OR CATALINA

SMOKE ALARM GUARD protects against damage, vandalism, theft, and battery removal.

P/N	DESCRIPTION
SDG	Smoke Alarm Guard, 3 ³ / ₈ " x 7 ⁵ / ₈ "



9000278



COPB



9000113



L522EN

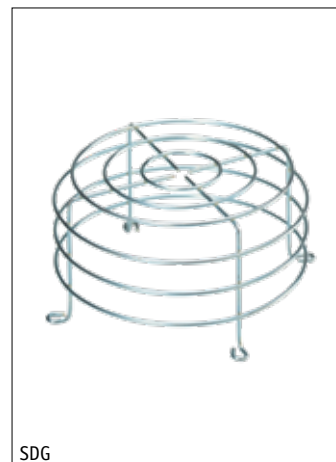

SDG



PRB128



PRB127



PRB124



BAT127

Power Rite™ ALARM PANEL BATTERIES are tough, long lasting, and powerful.

P/N	DESCRIPTION	L X H X W	CASE QTY
PRB121	12V, 1.3 Ah	3 ¹³ / ₁₆ " x 2 ¹ / ₁₆ " x 1 ¹¹ / ₁₆ "	20
PRB124	12V, 4 Ah	3 ⁹ / ₁₆ " x 4" x 2 ³ / ₄ "	10
PRB125	12V, 5 Ah	3 ⁹ / ₁₆ " x 4" x 2 ³ / ₄ "	10
PRB127	12V, 7 Ah	5 ¹⁵ / ₁₆ " x 3 ³ / ₄ " x 2 ⁹ / ₁₆ "	8
PRB128	12V, 8 Ah	5 ¹⁵ / ₁₆ " x 3 ³ / ₄ " x 2 ⁹ / ₁₆ "	8
→ PRB12105	12V, 10.5 Ah	5 ¹⁵ / ₁₆ " x 4 ³ / ₈ " x 2 ⁹ / ₁₆ "	5
PRB1212	12V, 12 Ah	5 ¹⁵ / ₁₆ " x 3 ¹¹ / ₁₆ " x 3 ⁷ / ₈ "	4
PRB1218	12V, 18 Ah	7 ¹ / ₈ " x 6 ⁹ / ₁₆ " x 3"	2
PRB1226	12V, 26 Ah	6 ⁹ / ₁₆ " x 4 ¹³ / ₁₆ " x 6 ⁷ / ₈ "	1
PRB1233NB*	12V, 33 Ah	7 ¹³ / ₁₆ " x 6 ¹ / ₄ " x 5 ³ / ₁₆ "	1
→ PRB1240NB*	12V, 40 Ah	7 ³ / ₄ " x 6 ¹¹ / ₁₆ " x 6 ¹ / ₂ "	1
PRB1255U*	12V, 55 Ah	9 ¹ / ₁₆ " x 8 ¹ / ₈ " x 5 ⁷ / ₁₆ "	1
PRB1275U*	12V, 75 Ah	10 ¹ / ₄ " x 8 ⁷ / ₈ " x 6 ⁷ / ₈ "	1
PRB12100U*	12V, 100 Ah	12 ¹⁵ / ₁₆ " x 9 ³ / ₈ " x 6 ⁷ / ₈ "	1

*INCLUDES NUT AND BOLT CONNECTION

Power-Sonic BAT SERIES ALARM PANEL BATTERIES—unparalleled reliability at a reasonable price.

P/N	DESCRIPTION	L X H X W	CASE QTY
BAT125	12V, 5 Ah	3 ⁹ / ₁₆ " x 4" x 2 ³ / ₄ "	10
BAT127	12V, 7 Ah	5 ¹⁵ / ₁₆ " x 3 ¹¹ / ₁₆ " x 2 ⁹ / ₁₆ "	5
→ BAT12105	12V, 10.5 Ah	5 ¹⁵ / ₁₆ " x 4 ³ / ₈ " x 2 ⁹ / ₁₆ "	5
BAT1212	12V, 12 Ah	5 ¹⁵ / ₁₆ " x 3 ¹³ / ₁₆ " x 3 ⁷ / ₈ "	4
BAT1218	12V, 18 Ah	7 ¹ / ₈ " x 6 ⁹ / ₁₆ " x 3"	2
BAT1218NB*	12V, 18 Ah	7 ¹ / ₈ " x 6 ⁹ / ₁₆ " x 3"	2
BAT1226	12V, 26 Ah	6 ⁹ / ₁₀ " x 4 ¹³ / ₁₆ " x 7"	1
BAT1233NB*	12V, 33 Ah	7 ¹³ / ₁₆ " x 6 ¹ / ₄ " x 5 ³ / ₁₆ "	1
→ BAT1240NB*	12V, 40 Ah	7 ³ / ₄ " x 6 ¹¹ / ₁₆ " x 6 ¹ / ₂ "	1
BAT1255U*	12V, 55 Ah	9" x 5 ¹ / ₂ " x 8 ¹ / ₈ "	1
BAT1275U*	12V, 75 Ah	10 ¹ / ₄ " x 6 ¹¹ / ₁₆ " x 8 ¹ / ₈ "	1
BAT12100U*	12V, 100 Ah	12 ¹⁵ / ₁₆ " x 9 ³ / ₈ " x 6 ⁷ / ₈ "	1

*INCLUDES NUT AND BOLT CONNECTION

For Additional Batteries, See Section 8.

This **ADAPTER** converts a nut and bolt terminal to a spade terminal on batteries, eliminating the need to cut and splice battery leads.

NOTE: Fits BAT series only.

P/N	DESCRIPTION
NBF2	Terminal Adapter



NBF2

NBF2 In Use

RECYCLING

BATTERY RECYCLING Available.
Ask Your Account Manager for Details.



00

EXIT & EMERGENCY LIGHTING



EXIT SIGNS AND EMERGENCY LIGHTS

Brooks' EXIT SIGNS with flame-resistant, high-impact thermoplastic housings feature LED lighting, solid-state chargers, universal mounting, test buttons, low-voltage disconnects, LED indicators, and replaceable pop-out chevrons. UL listed for damp locations. 120/277 VAC. Five-year warranty. Measures 12³/₄" x 7¹/₂" x 1³/₄".

P/N	DESCRIPTION
LEDAC	Red LED Exit Sign (AC Only), White
LED1	Red LED Exit Sign w/ Battery Backup, White
LED1B	Red LED Exit Sign w/ Battery Backup, Black
LED1SDT	Red LED Exit Sign w/ Battery Backup & Self-Diagnostic Testing, White
LED6	Green LED Exit Sign w/ Battery Backup, White

Brooks' LED5 EXIT SIGN features a 20 ga steel housing with knockout chevrons. The **EDGE1 EXIT SIGN** features a UV-stabilized edge-lit acrylic sign panel with self-adhesive chevrons. Both include LED lighting, solid-state chargers, push-to-test switches, and "ON" LED indicators. UL listed for damp locations. 120/277 VAC. Five-year warranty.

P/N	DESCRIPTION	L X H X W
LED5	Red LED Exit Sign w/ Battery Backup, Steel Enclosure	12 ¹ / ₂ " x 8 ⁵ / ₈ " x 2"
EDGE1	Red LED Edge Lit Exit Sign, Alum Canopy	13 ³ / ₄ " x 11" x 1 ³ / ₄ "

The **Lithonia EXIT SIGN** with flame-resistant thermoplastic construction and a snap-together design installs fast. Features include LED lighting, spare faceplate for double-face conversion, universal mounting kit, and knockout chevrons. UL listed for damp locations. 120/277 VAC. Five-year warranty.

P/N	DESCRIPTION	L X H X W
LED2	Red LED Exit Sign w/ Battery Backup	11 ³ / ₄ " x 7 ⁵ / ₈ " x 2"

→ **More LITHONIA PRODUCTS Available - Call for Pricing.**

This **NEW YORK CITY APPROVED EXIT SIGN** features 8" EXIT letters and a 20 ga steel housing. Energy efficient and easy-to-install, it comes with energy-saving LEDs and universal knockout chevrons. UL listed for damp locations. 120/277 VAC. Five-year warranty.

P/N	DESCRIPTION	L X H X W
NYLED1	Red LED Exit Sign w/ Battery Backup	14 ³ / ₈ " x 10 ⁷ / ₁₆ " x 2 ¹ / ₄ "

EverGlow® PHOTO-LUMINESCENT EXIT SIGNS are affordable, made of aluminum, and contain no radioactive or toxic components. They come with mounting hardware and two self-adhesive chevrons. They require a minimum of five foot-candle lighting on the sign face at all times when the building is occupied. Available in green or red. Measures 13³/₈" x 8¹/₂".

P/N	DESCRIPTION
BPLXG	Photo-Luminescent Exit Sign, Green
BPLXR	Photo-Luminescent Exit Sign, Red
BPLT2X10	Photo-Luminescent Tape, 1 ¹ / ₂ " x 10 m

Tritium-powered **SELF-LUMINOUS EXIT SIGNS** require no external power to operate, are always on, and always meet code. Available with a 10- or 20-year life, they need no electricity, batteries, bulbs, wiring, or maintenance. They are explosion and corrosion proof and lightweight and easy to install. Meets NFPA 101 standards and are UL listed. Measures 12³/₄"L x 8¹/₄"H x 1"D. Available with gray, white, or black frames. Custom wording available too. Call the Sales Department for more information. **NOTE:** It is normal for the sign to appear dim during daylight hours. Due to government regulations, these signs must be registered by name and address of end user.

P/N	DESCRIPTION
DDPSPE10B	10-Year Exit Sign, Red w/ Black Frame
DDPSPE10G	10-Year Exit Sign, Red w/ Gray Frame
DDPSPE10W	10-Year Exit Sign, Red w/ White Frame
DDPSPE20B	20-Year Exit Sign, Red w/ Black Frame
DDPSPE20G	20-Year Exit Sign, Red w/ Gray Frame
DDPSPE20W	20-Year Exit Sign, Red w/ White Frame

→ **More SELF-LUMINOUS EXIT SIGNS Available - Call for Pricing.**

CHICAGO APPROVED EXIT/STAIRS SIGNS come with energy-saving LEDs and push-to-test switches. Other features include rechargeable NiCad battery backups, 20 ga steel housings, and canopy mounting kits. UL listed. Meets City of Chicago requirements. 120/277 VAC. Arrows sold separately (glass only).

P/N	DESCRIPTION	L X H X W
CHEX	Red Exit Sign	12 ³ / ₈ " x 11 ¹ / ₄ " x 2 ³ / ₈ "
DA	Double Arrows For CHEX	
RA	Right Arrows For CHEX	
LA	Left Arrows For CHEX	
CHEXST	Red Stairs Sign	13 ⁷ / ₈ " x 11 ¹ / ₄ " x 2 ³ / ₈ "
SWDA	Double Arrows For CHEXST	
SWRA	Right Arrows For CHEXST	
SWLA	Left Arrows For CHEXST	

Brooks' WET-LOCATION EXIT SIGN is ideal for industries where water spray or splash is an issue or in highly humid, oily, corrosive non-hazardous environments. It incorporates a low-voltage disconnect, test button, LED indicator, and solid-state charger and is NEMA 4X rated. UL listed for damp and wet locations. 120/277 VAC. Five-year warranty. Measures 13¹/₄" x 9³/₂" x 3⁷/₁₆".

P/N	DESCRIPTION
LED4X	Wet-Location Exit Sign

Brooks **COMPACT WET LOCATION LED EXIT SIGNS** feature flame-resistant, high-impact thermoplastic housings that are suitable for wet locations as well as freezer applications. Features include LED lighting, solid-state chargers, universal mounting, solid-state transfer switches, knockout chevrons, and bi-color LED indicator lights for battery check. UL listed for wet locations. 120/277 VAC. Measures 12¹/₂" x 8¹/₂" x 2¹/₂".

P/N	DESCRIPTION
→ WETEXR1	Compact Wet-Location Red LED Exit Sign, Single Face
→ WETEXR2	Compact Wet-Location Red LED Exit Sign, Double Face



Combine Quality With Value



LED4SPRC



LED4B

Brooks' COMBINATION UNITS meet both exit sign and emergency lighting needs in one economical unit. Their low-profile design comes in a neutral finish, assembled in an injection-molded, flame-resistant, high-impact thermoplastic housing. They also feature a solid-state charger, universal mounting, push-to-test switch, low-voltage disconnect, LED indicator, and universal pop-out chevrons. UL listed for damp locations. 120/277 VAC. Five-year warranty.

P/N	DESCRIPTION	L X H X W
→ LED4SPRC	Red LED Exit Sign/ Emergency Light w/ Remote Power & Ultra-Bright LED Lamps, White	21" x 9" x 2"
LED4	Red LED Exit Sign/ Emergency Light, White	23" x 11" x 2 ³ / ₄ "
LED4B	Red LED Exit Sign/ Emergency Light, Black	23" x 11" x 2 ³ / ₄ "
LED4H0	Red LED Exit Sign/ Emergency Light w/ 11 W Remote Power, White	23" x 11" x 2 ³ / ₄ "
LED4SDT	Red LED Exit Sign/ Emergency Light w/ Self-Diagnostic Testing, White	23" x 11" x 2 ³ / ₄ "
LED7	Green LED Exit Sign/ Emergency Light, White	23" x 11" x 2 ³ / ₄ "



LED4MINI

This **Brooks COMBO MICRO LED EXIT SIGN & EMERGENCY LIGHT** features high-impact thermoplastic construction and a snap-fit faceplate. It comes with field-replaceable chevrons and a universal mounting knockout for J-boxes. Other features include adjustable, glare-free lighting heads; test switch; status indicator; and NiCad battery. UL listed for damp locations. 120/277 VAC. Five-year warranty. Measures 18" x 7¹/₈" x 1³/₄".

P/N	DESCRIPTION
LED4MINI	Micro Red LED Exit Sign/Emergency Light



LED10

The innovative and sleek **EXIT & EMERGENCY LIGHT COMBO SIGNS**, from **Brooks**, offer unique designs, combining energy-efficient LED exit signs with LED emergency light, all in one low-profile unit. Maintenance-free, they have dual voltage with rechargeable NiCad batteries and can be universally mounted. Available with red or green lettering and remote capabilities come standard. UL listed for damp locations. 120/277 VAC. Five-year warranty. Measures 12⁹/₁₆" x 9¹/₈" x 1⁷/₈".

P/N	DESCRIPTION
LED10	Red Exit Sign/Emergency Light
LED10G	Green Exit Sign/Emergency Light
LED10SDT	Red Exit Sign/Emergency Light w/ Self-Diagnostic Testing

This **CHICAGO APPROVED EXIT/EMERGENCY LIGHT** is long lasting and energy efficient. It comes standard with two 6V, 5.3 W adjustable LED lamp heads and a canopy for top or end mounting. There is a universal K/O pattern on the back plate for wall mounting, while a 20 ga steel housing ensures longevity. Provides 120-minutes of emergency illumination. Meets UL924, NFPA 101 Life Safety Code, NEC, OSHA, and local & state codes. UL listed for damp locations. 120/277 VAC. Five-year warranty. Measures 12³/₈" x 16³/₁₆" x 5⁵/₈".

P/N DESCRIPTION
CHEXCOMBO Chicago Red LED Exit Sign/Emergency Light



Easy to install, this **NEW YORK CITY APPROVED EXIT/EMERGENCY LIGHT** features a 20 ga steel housing, energy-saving LEDs, universal knockout chevrons, and three fully adjustable 12 W lamp heads. UL listed. 120/277 VAC. Five-year warranty. Measures 14⁵/₈" x 16⁵/₁₆" x 4⁷/₈".

P/N DESCRIPTION
NYLED4 NYC Red LED Exit Sign/Emergency Light



Emergi-Lite's WET-LOCATION EXIT SIGN and EMERGENCY LIGHT is ideal for industries where water spray or splash is an issue or in highly humid, oily, corrosive non-hazardous environments. Its PVC body will not dent, peel, or corrode, and its polycarbonate cover is attached with stainless steel tamper-resistant screws. NEMA 4X rated. UL listed for damp and wet locations. 120/277 VAC. Five-year warranty. Measures 13¹/₄" x 12⁵/₈" x 3⁷/₁₆".

P/N DESCRIPTION
LED4XCOMBO Survive-All SVX Series Combo Exit Sign/Emergency Light

Brooks' WEATHER-RESISTANT LED REMOTE HEADS and INDOOR LED REMOTE HEADS feature multi-voltage capability for use with 3.6V, 6V, 9.6V, and 12V emergency lights. Long lasting, efficient, 1 W, ultra-bright white LED lamp heads include high-performance, chrome-plated metallized reflectors and plastic lenses (glass lenses on weather-resistant models) with eight LED's in each lamp head for optimal light distribution. Suitable for wall or ceiling mounting. Five-year warranty.



P/N	DESCRIPTION	L X H X W
→ LED1RHWR	3.6V-12V, 1 W Weather-Resistant Remote Head, Gray	4 ¹ / ₄ " x 6 ⁵ / ₈ " x 4 ¹ / ₄ "
→ LED2RHWR	3.6V-12V, 1 W Weather-Resistant Dual Remote Heads, Gray	4 ¹ / ₄ " x 6 ³ / ₄ " x 10 ³ / ₈ "
→ LED1RH	3.6V-12V, 1 W Indoor Remote Head, White	5 ⁷ / ₈ " x 4 ⁷ / ₈ " x 4 ¹ / ₂ "
→ LED2RH	3.6V-12V, 1 W Indoor Dual Remote Heads, White	6" x 5" x 4 ¹ / ₂ "





BELR1



BELR3



→ NEW

BLEDR1



BELR1LED



BELR5

Brooks' LOW-PROFILE EMERGENCY LIGHTS feature flame-resistant, high-impact thermoplastic housings. Universal mounting with "EZ" quick connects, push-to-test switches, solid-state chargers, low-voltage disconnects, and power-on LED indicator lights are standard. Fixed or fully adjustable, glare-free dual lighting heads are included. **BELR2** has remote capabilities of up to 11 lamp watts. UL or ETL listed for damp locations. 120/277 VAC. Five-year warranty.

P/N	DESCRIPTION	L X H X W
BELR1	6V, 10.8 W Light, White	16" x 5 ¹ / ₈ " x 4 ⁷ / ₈ "
BELR1B	6V, 10.8 W Light, Black	16" x 5 ¹ / ₈ " x 4 ⁷ / ₈ "
BELR2	6V, 22 W Light, White	16" x 5 ¹ / ₈ " x 4 ⁷ / ₈ "
BELR3	6V, 10.8 W Fixed-Head, White	11 ¹³ / ₁₆ " x 5 ¹ / ₈ " x 2 ³ / ₈ "
BELR3B	6V, 10.8 W Fixed-Head, Black	11 ¹³ / ₁₆ " x 5 ¹ / ₈ " x 2 ³ / ₈ "
BELR1LESDT	3.6V, 2 W LED Light w/ Self-Diagnostic Testing, White	14 ³ / ₈ " x 3 ³ / ₄ " x 3 ³ / ₄ "
→ BLEDR1	3.6V, 1 W Light, White	14 ³ / ₈ " x 3 ³ / ₄ " x 3 ³ / ₄ "

Brooks' MICRO EMERGENCY LIGHTS feature a contemporary design with premium options in a stylish yet economical package. Lights come standard with fully adjustable, glare-free light heads built into UV stabilized, high-impact thermoplastic housings. Their snap-together construction and universal mounting plates make installation a snap, while test switches, status indicators, and NiCad batteries make them a smart choice. The **BELR2LED** features high brightness and remote load capacity. UL listed for damp locations. 120/277 VAC. Five-year warranty.

P/N	DESCRIPTION	L X H X W
BELR1LED	Micro Light	9" x 4 ³ / ₄ " x 2 ³ / ₄ "
BELR2LED	Micro Light, High Bright	9" x 4 ³ / ₄ " x 2 ³ / ₄ "
8RHLED	3V, 1 W Remote Head	5 ⁷ / ₈ " x 4 ⁷ / ₈ " x 4 ¹ / ₂ "
10RHLED	3V, 2 W Remote Head	6" x 5" x 4 ¹ / ₂ "

Brooks' EMERGENCY LIGHTS feature flame-resistant, high-impact thermoplastic housings; push-to-test switches; solid-state chargers; low-voltage disconnects; and power-on LED indicator lights. They come with fully adjustable, glare-free dual lighting heads. UL listed for dry locations. 120/277 VAC. Five-year warranty.

P/N	DESCRIPTION	L X H X W
BELR4	6V, 50 W Light	12 ³ / ₄ " x 14 ³ / ₁₆ " x 3 ¹ / ₄ "
BELR5	12V, 50 W Light	12 ³ / ₄ " x 14 ³ / ₁₆ " x 3 ¹ / ₄ "

→ **More Brooks' EMERGENCY LIGHTS Available - Call for Pricing.**

CHICAGO APPROVED EMERGENCY LIGHT features 20 ga steel housing, push-to-test switch, and a rechargeable sealed lead calcium battery. UL listed for damp locations. Meets City of Chicago requirements. 120/277 VAC. Five-year warranty.

P/N	DESCRIPTION	L X H X W
CHX	6V, 27 W Light	13" x 11 1/2" x 2 7/8"

Lithonia's EMERGENCY LIGHTING UNIT features LED lamps and a unique UV-stabilized thermoplastic housing that resists discoloration. It has a track-and-swivel design that permits a full-range of adjustment on its lamp heads and can be mounted on the wall or ceiling. UL listed for damp locations. 120/277 VAC. Five-year warranty.

P/N	DESCRIPTION	L X H X W
ELM2LED	3.6V, 3 W Light	10 1/4" x 4 1/4" x 2 3/4"

→ **More Lithonia EMERGENCY LIGHTING UNITS Available - Call for Pricing.**

The **Dual-Lite EZ-2** is an energy-efficient **COMPACT EMERGENCY LIGHT** made of injection-molded, flame-rated white thermoplastic. Uses two 6V, 5.4 W incandescent lamps. UL listed for dry locations. 120/277 VAC. Three-year warranty.

P/N	DESCRIPTION	L X H X W
EZ2	6V, 10.8 W Light	16 9/16" x 5 3/16" x 4 7/8"

This **Lithonia EMERGENCY LIGHTING UNIT** features powerful LED lamps that offer maximum center-to-center spacing of up to 75' and 90 minutes of constant light during emergency operation. It comes standard with a UV-stabilized thermoplastic housing that resists discoloration, impacts, and scratches. It is also ceiling or wall mountable, and its track-and-swivel design allows for full lamp head adjustment. UL listed for damp locations. 120/277 VAC. Five-year warranty.

P/N	DESCRIPTION	L X H X W
→ BELMLT	9.6V, 10.8 W Light	12 1/2" x 5" x 3 3/4"

Brooks' INDUSTRIAL EMERGENCY LIGHTS are manufactured from rugged die-formed steel and feature remote capabilities, low-voltage disconnects, push-to-test switches, and LED indicators. All feature 9 W PAR 36-type lamp heads. UL listed. 120/277 VAC. Three-year warranty.

P/N	DESCRIPTION	L X H X W
BRL510	6V, 27 W Light	12 3/4" x 14 5/8" x 3 1/8"
B12RL1459	12V, 54 W Light	12 3/4" x 14 5/8" x 3 1/8"
B12RL1859	12V, 110 W Light	16 1/8" x 16 3/8" x 5 7/16"

NEW YORK CITY APPROVED EMERGENCY LIGHTS feature rugged 20 ga steel housings and are easy-to-install. They are completely self-contained and fully automatic. The 6V unit has 9 W Par 36 sealed-beam lamps, while the 12V unit has 12 W Par 36 sealed-beam lamps and include low-voltage disconnects and brown-out protection. UL listed for dry locations. 120/277 VAC. Five-year warranty.

P/N	DESCRIPTION	L X H X W
BNY62189	6V, 18 W Light	10 1/8" x 15 7/8" x 2 1/2"
BNY63279	6V, 27 W Light	14 1/2" x 16 1/2" x 2 1/2"
BNY123509	12V, 50 W Light	14 1/2" x 16 1/2" x 2 1/2"



CHX



ELM2LED



EZ2



→ **NEW**

BELMLT



B12RL1459



BNY63279



CEW11

The **CEW11 EMERGENCY LIGHT** is completely self-contained with a low-profile design in a white finish. It features a push-to-test switch, solid-state charger, and low-voltage disconnect and comes with 6V, 7.5 W MR 16 halogen lamps. UL listed for damp locations. 120/277 VAC. Three-year warranty.

P/N	DESCRIPTION	L X H X W
CEW11	6V, 15 W Light	12 ¹ / ₈ " x 5 ¹ / ₂ " x 3 ³ / ₄ "



BREL4X

This **VANDAL RESISTANT EMERGENCY LIGHT** comes with a cast aluminum back plate, clear polycarbonate cover, and tamper-proof screws (installation bit included). It also includes 6V, 18 W MR 16 halogen lamps. NEMA4X rated and UL listed. Three-year warranty.

P/N	DESCRIPTION	L X H X W
BREL4X	6V, 18 W Vandal-Resistant Light	17 ³ / ₄ " x 7" x 5 ³ / ₄ "



→ NEW

BRMR16LED

Brooks' ALL-WEATHER EMERGENCY LIGHTS are ideal for industries where water spray or splash is an issue or in high-humidity, oily, corrosive non-hazardous environments. Each unit incorporates a low-voltage disconnect, test button, LED indicator, and solid-state charger. UL listed for wet locations. 120/277 VAC. Five-year warranty.

P/N	DESCRIPTION	L X H X W
BTFX2	6V, 14.4 W Light	8 ³ / ₈ " x 12 ⁷ / ₈ " x 6"
→ BRMR16LED	6V, 16.6 W LED Light	14 ¹³ / ₁₆ " x 5 ⁵ / ₈ " x 4 ¹ / ₂ "

Brooks' EMERGENCY FLUORESCENT PACK provides 700 initial lumens and can power one or two of the existing lamps for a minimum of 90 minutes. It contains a battery, charger, and inverter circuit and is mountable in the ballast chamber or on top of the fixture. Includes a time delay feature to overcome end-of-life circuit protection. Powers a single or dual 2'-8' rapid, instant, or energy-saving **TB-T12**, **HO**, or **VHO** lamp.

P/N	DESCRIPTION
→ FB60TD	Fluorescent Pack



→ NEW

FB60TD

ACCESSORIES

P/N	DESCRIPTION	L X H X W
ESG	Exit Sign Guard	13 ⁵ / ₈ " x 13 ⁵ / ₈ " x 4 ¹ / ₂ "
WG1*	Guard For BELR & ELM	13 ³ / ₄ " x 15 ¹ / ₄ " x 6"
3LC	Line Cord, 3'	
LENS3	Red Day-Glo LED Exit Lens	11 ¹³ / ₁₆ " x 6 ⁹ / ₁₆ "
LENS4	Green Day-Glo LED Exit Lens	11 ³ / ₄ " x 6 ⁵ / ₁₆ "

*Use (2) WG1 WIRE GUARD UNITS FOR EXIT COMBO LIGHTS.

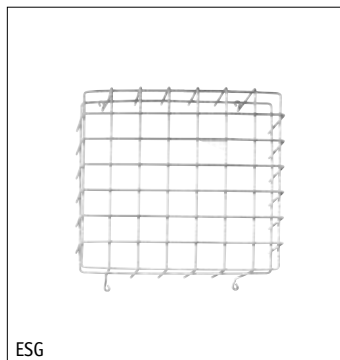

ESG

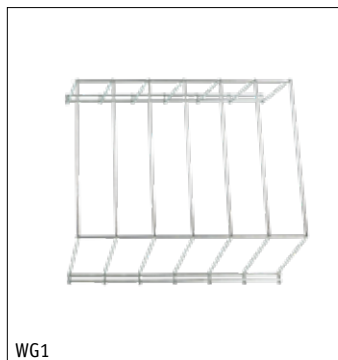

WG1

Brooks' WEATHER-RESISTANT LED REMOTE HEADS and **INDOOR LED REMOTE HEADS** feature multi-voltage capability for use with 3.6V, 6V, 9.6V, and 12V emergency lights. Long lasting, efficient, 1 W, ultra-bright white LED lamp heads include high-performance, chrome-plated metallized reflectors and plastic lenses (glass lenses on weather-resistant models) with eight LED's in each lamp head for optimal light distribution. Suitable for wall or ceiling mounting. Five-year warranty.

P/N	DESCRIPTION	L X H X W
→ LED1RHWR	3.6V-12V, 1 W Weather-Resistant Remote Head, Gray	4 ¹ / ₄ " x 6 ⁵ / ₈ " x 4 ¹ / ₄ "
→ LED2RHWR	3.6V-12V, 1 W Weather-Resistant Dual Remote Heads, Gray	4 ¹ / ₄ " x 6 ³ / ₄ " x 10 ³ / ₈ "
→ LED1RH	3.6V-12V, 1 W Indoor Remote Head, White	5 ⁷ / ₈ " x 4 ⁷ / ₈ " x 4 ¹ / ₂ "
→ LED2RH	3.6V-12V, 1 W Indoor Dual Remote Heads, White	6" x 5" x 4 ¹ / ₂ "

The **ECL230** is a battery-powered **EXIT CONTROL LOCK ALARM**, from **DETEX**, that secures doors requiring an alarmed exit device. Its 100 dB solid-state directional alarm sounds in the event of an unauthorized exit, while its rigid die-cast case and Braille warning offer additional safety measures. It comes with an alarm control key, surface door mount, and 9V battery. Lock cylinder for **ECL230** and **EA500** are sold separately. ADA compliant. UL listed.

P/N	DESCRIPTION
ECL230	Exit Control Lock Alarm
EA500	Exit Alarm Door Lock
ECL445K	Lock Cylinder Kit
	For ECL230
ECL500K	Mortise Cylinder Lock
	For EA500
ECLK	Set of 10 Keys
	For Servicing ECL230 & EA500
ECLNP	Replacement Nameplate
	For ECL230
L522EN*	Ultimate Lithium Battery

*Unavailable in AK, HI, PR, or Catalina

Made of virtually indestructible polycarbonate, **STI's EXIT STOPPER** deters unauthorized exits or entries through emergency exit doors. It features a highly visible stop sign, a powerful alarm that sounds a 105 dB warning horn when activated, and a key-operated override that silences the alarm. 9V battery included.

P/N	DESCRIPTION
STI6400	Exit Stopper
L522EN*	Ultimate Lithium Battery

*Unavailable in AK, HI, PR, or Catalina





BELB1201N

REPLACEMENT BATTERIES FOR EXIT AND EMERGENCY LIGHTS

Brooks' NICAD REPLACEMENT BATTERY is a direct replacement for **Lithonia's LED Exit Signs** that use a single 1.2V, 1200 mAh cell.

P/N	DESCRIPTION
BELB1201N	1.2V NiCad Battery



NiCAD REPLACEMENT PACKS

NICAD REPLACEMENT PACKS are shipped with flying leads. **NOTE:** Remember to save the connectors from the existing packs so you can splice to the new pack!

P/N	DESCRIPTION
BNP2700A	2.4V, 700 mAh, Conf. A
BNP2700B	2.4V, 700 mAh, Conf. B
BNP3700A	3.6V, 700 mAh, Conf. A
BNP3700B	3.6V, 700 mAh, Conf. B
BNP3700DX	3.6V, 700 mAh, Conf. D
BNP4700A	4.8V, 700 mAh, Conf. A
BNP4700B	4.8V, 700 mAh, Conf. B
BNP4700C	4.8V, 700 mAh, Conf. C
BNP4700AA	4.8V, 800 mAh, Conf. AA
BNP5700A	6V, 700 mAh, Conf. A
BNP5700B	6V, 700 mAh, Conf. B
BNP5700DX	6V, 700 mAh, Conf. D
BNP8700AA	9.6V, 700 mAh, Conf. AA
BNP11200WL	1.2V, 1200 mAh
BNP21200A	2.4V, 1200 mAh, Conf. A
BNP41200A	4.8V, 1200 mAh, Conf. A
BNP41200B	4.8V, 1200 mAh, Conf. B
BNP51200A	6V, 1200 mAh, Conf. A
BNP51500B	6V, 1500 mAh, Conf. B
BNP51200B	6V, 1200 mAh, Conf. B
BNP52000AA	6V, 2000 mAh, Conf. AA
BNP52000B	6V, 2000 mAh, Conf. B
BNP52200A	6V, 2200 mAh, Conf. A
BNP52500B	6V, 2500 mAh, Conf. B
BNP54000B	6V, 4000 mAh, Conf. B
BNP54000DX	6V, 4000 mAh, Conf. D
BNP57000B	6V, 7000 mAh, Conf. B
BNP107000C	12V, 7000 mAh, Conf. C

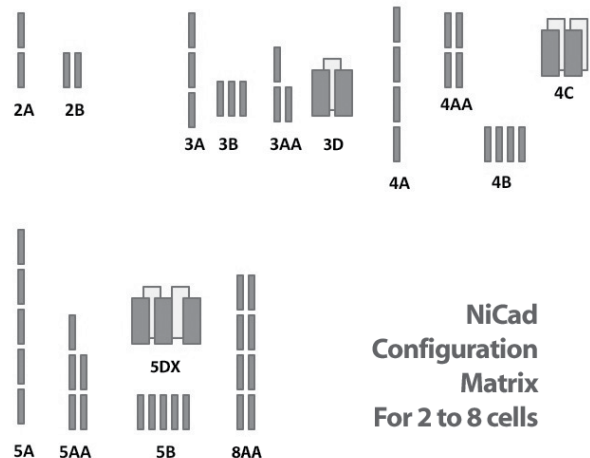

NiCAD CONFIGURATIONS

Energizer® Ultimate Lithium® BATTERY operates in all temperature extremes (-40°F to 140°F) and can last up to 10 years as a backup in AC-powered smoke detectors. Complies with ANSI 9V dimensional specs for alkaline and lithium batteries.



L522EN



466M

P/N	DESCRIPTION
L522EN*	Ultimate Lithium 9V Battery
	*Unavailable in AK, HI, PR, or Catalina

The **Eveready® Super Heavy Duty® 6V LANTERN BATTERY** comes from a line of carbon zinc battery products that has powered battery-run devices for over 100 years.

P/N	DESCRIPTION
466M	6V Lantern Battery

Energizer® Industrial® ALKALINE BATTERIES are designed for today's heavy-current or continuous-use applications, offering long-lasting power over a range of sizes. They operate well in extreme temperatures (0°F to 130°F) and boast an excellent shelf life—alkaline cells can be used even after 10 years of storage.



ALKALINE BATTERIES

P/N	DESCRIPTION
ALK92*	Industrial AAA Alkaline Battery
ALK91*	Industrial AA Alkaline Battery
ALK93	Industrial C Alkaline Battery
ALK95	Industrial D Alkaline Battery
ALK22	Industrial 9V Alkaline Battery

*AAA AND AA BATTERIES MUST BE PURCHASED IN QUANTITIES OF 4.

TruForce™ Industrial ALKALINE BATTERIES are long-lasting, low-cost alternatives with the power to run all of your devices. And they offer up to a 10-year shelf life.

P/N	DESCRIPTION
TFAAAB	Industrial AAA Alkaline Batteries, Pkg/4
TFAAB	Industrial AA Alkaline Batteries, Pkg/4
TFCB	Industrial C Alkaline Batteries, Pkg/2
TFDB	Industrial D Alkaline Batteries, Pkg/2
TF9VB	Industrial 9V Alkaline Battery



TRUFORCE INDUSTRIAL ALKALINE BATTERIES

REPLACEMENT BATTERIES

Power Rite® BATTERIES are a top pick for emergency lights and other equipment needing dependable power that lasts.

P/N	DESCRIPTION	L X H X W	CASE QTY
PRB64	6V, 4.5 Ah	2 3/4" x 4" x 1 7/8"	20
PRB67	6V, 7 Ah	6" x 3 3/4" x 1 3/8"	14
PRB612	6V, 12 Ah	6" x 3 3/4" x 2"	10
PRB623	6V, 2.3 Ah	1 13/16" x 3" x 1 7/16"	10



PRB64



PRB612

Power-Sonic® BAT SERIES REPLACEMENT BATTERIES provide unparalleled reliability at a reasonable cost.

P/N	DESCRIPTION	L X H X W	CASE QTY
BAT445	4V, 4.5 Ah	1 7/8" x 3 3/4" x 2 1/16"	20
BAT410	4V, 10 Ah	4 1/16" x 3 3/4" x 2"	10
→ BAT63	6V, 3.5 Ah	5 9/32" x 2 11/32" x 1 11/32"	1
BAT64	6V, 4.5 Ah	2 13/16" x 4 1/16" x 1 15/16"	20
BAT67	6V, 7 Ah	6" x 3 3/4" x 1 3/8"	10
BAT68	6V, 9 Ah	3 7/8" x 4 11/16" x 2 1/4"	10
BAT695	6V, 12 Ah	4 1/4" x 5 9/16" x 2 3/4"	5
BAT612	6V, 12 Ah	5 15/16" x 3 3/4" x 2"	10
BAT620NB*	6V, 20 Ah	6 3/16" x 4 7/8" x 3 3/16"	4
BAT636	6V, 36 Ah	6 7/16" x 6 1/2" x 3 1/2"	2

*INCLUDES NUT AND BOLT CONNECTION



BAT SERIES BATTERIES

See page 160 for Alarm Batteries.

PURE-LEAD BATTERIES round out **Brooks'** extensive replacement-battery lineup.

P/N	DESCRIPTION	L X H X W	CASE QTY
0120704	4V, 5 Ah	3 3/16" x 3" x 2 1/8"	24
0120770	4V, 5 Ah	2 1/2" x 3 3/16" x 2 1/8"	24
0120705	4V, 8 Ah	3 3/16" x 4" x 2 1/8"	24
0120706	6V, 5 Ah	5 1/2" x 3" x 2 1/8"	16
0120707	6V, 8 Ah	5 1/2" x 4" x 2 1/8"	16



0120770



0120707

BATTERY RECYCLING PROGRAM INFORMATION
Available online at
www.BrooksEquipment.com/BatteryRecycling



Power Rite® ALARM BATTERIES are tough, long lasting, and powerful.

P/N	DESCRIPTION	L X H X W	CASE QTY
PRB121	12V, 1.3 Ah	3 ¹³ / ₁₆ " x 2 ¹ / ₁₆ " x 1 ¹¹ / ₁₆ "	20
PRB124	12V, 4 Ah	3 ⁹ / ₁₆ " x 4" x 2 ³ / ₄ "	10
PRB125	12V, 5 Ah	3 ⁹ / ₁₆ " x 4" x 2 ³ / ₄ "	10
PRB127	12V, 7 Ah	5 ¹⁵ / ₁₆ " x 3 ³ / ₄ " x 2 ⁹ / ₁₆ "	8
PRB128	12V, 8 Ah	5 ¹⁵ / ₁₆ " x 3 ³ / ₄ " x 2 ⁹ / ₁₆ "	8
→ PRB12105	12V, 10.5 Ah	5 ¹⁵ / ₁₆ " x 4 ³ / ₈ " x 2 ⁹ / ₁₆ "	5
PRB1212	12V, 12 Ah	5 ¹⁵ / ₁₆ " x 3 ¹¹ / ₁₆ " x 3 ⁷ / ₈ "	4
PRB1218	12V, 18 Ah	7 ¹ / ₈ " x 6 ⁹ / ₁₆ " x 3"	2
PRB1226	12V, 26 Ah	6 ⁹ / ₁₆ " x 4 ¹³ / ₁₆ " x 6 ⁷ / ₈ "	1
PRB1233NB*	12V, 33 Ah	7 ¹³ / ₁₆ " x 6 ¹ / ₄ " x 5 ³ / ₁₆ "	1
→ PRB1240NB*	12V, 40 Ah	7 ³ / ₄ " x 6 ¹¹ / ₁₆ " x 6 ¹ / ₂ "	1
PRB1255U*	12V, 55 Ah	9 ¹ / ₁₆ " x 8 ¹ / ₈ " x 5 ⁷ / ₁₆ "	1
PRB1275U*	12V, 75 Ah	10 ¹ / ₄ " x 8 ¹ / ₈ " x 6 ⁵ / ₈ "	1
PRB12100U*	12V, 100 Ah	12 ¹⁵ / ₁₆ " x 9 ³ / ₈ " x 6 ⁷ / ₈ "	1

*INCLUDES NUT AND BOLT CONNECTION



Power-Sonic® BAT SERIES REPLACEMENT BATTERIES—unparalleled reliability at a reasonable price.

P/N	DESCRIPTION	L X H X W	CASE QTY
BAT125	12V, 5 Ah	3 ⁹ / ₁₆ " x 4" x 2 ³ / ₄ "	10
BAT127	12V, 7 Ah	5 ¹⁵ / ₁₆ " x 3 ¹¹ / ₁₆ " x 2 ⁹ / ₁₆ "	5
→ BAT12105	12V, 10.5 Ah	5 ¹⁵ / ₁₆ " x 4 ³ / ₈ " x 2 ⁹ / ₁₆ "	1
BAT1212	12V, 12 Ah	5 ¹⁵ / ₁₆ " x 3 ¹³ / ₁₆ " x 3 ⁷ / ₈ "	4
BAT1218	12V, 18 Ah	7 ¹ / ₈ " x 6 ⁹ / ₁₆ " x 3"	2
BAT1218NB*	12V, 18 Ah	7 ¹ / ₈ " x 6 ⁹ / ₁₆ " x 3"	2
BAT1226	12V, 26 Ah	6 ⁹ / ₁₆ " x 4 ¹³ / ₁₆ " x 7"	1
BAT1233NB*	12V, 33 Ah	7 ¹³ / ₁₆ " x 6 ¹ / ₄ " x 5 ³ / ₁₆ "	1
→ BAT1240NB	12V, 40 Ah	7 ³ / ₄ " x 6 ¹¹ / ₁₆ " x 6 ¹ / ₂ "	1
BAT1255U*	12V, 55 Ah	9 ¹ / ₁₆ " x 8 ¹ / ₈ " x 5 ⁷ / ₁₆ "	1
BAT1275U*	12V, 75 Ah	10 ¹ / ₄ " x 8 ¹ / ₈ " x 6 ⁵ / ₈ "	1
BAT12100U*	12V, 100 Ah	12" x 8 ¹ / ₈ " x 6 ⁵ / ₈ "	1

*INCLUDES NUT AND BOLT CONNECTION

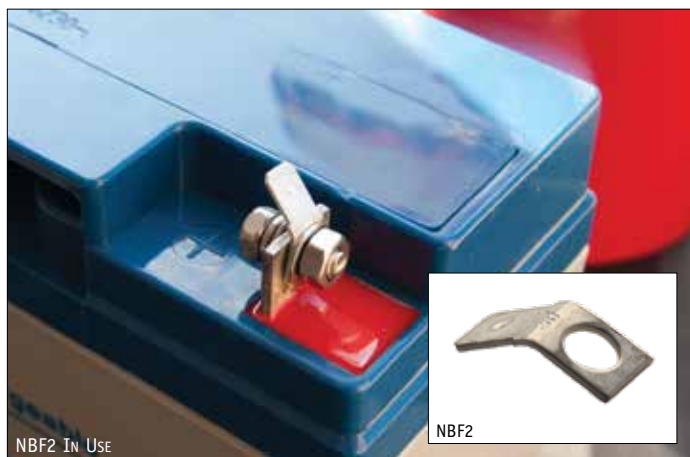

FREE FREIGHT ON CASE QUANTITIES AVAILABLE
Ask Your Account Managers for Details

This **ADAPTER** converts a nut and bolt terminal to a spade terminal on batteries, eliminating the need to cut and splice battery leads.

NOTE: Fits BAT series only.

P/N	DESCRIPTION
NBF2	Terminal Adapter

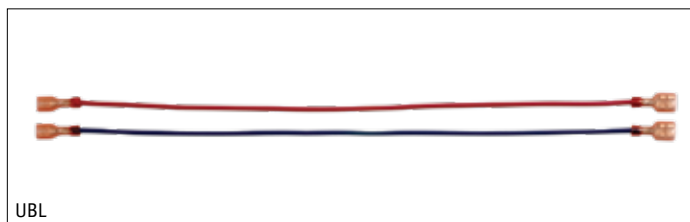

BATTERY LEADS

P/N	DESCRIPTION
UBL	Universal Battery Lead, Pkg/2
PBL	Plug Battery Lead

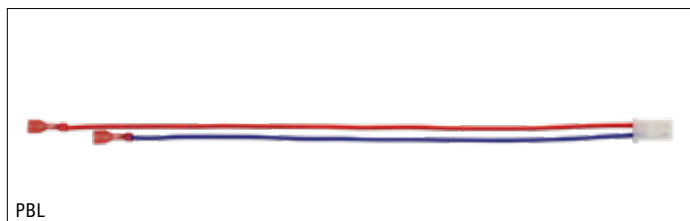

REPLACEMENT LAMPS

REPLACEMENT LAMPS for exit signs and emergency lighting.

P/N	DESCRIPTION
B170	4V, 7.2 W Lamp, Dbl Contact Bayonet (11-170)
B914	4V, 3.6 W Lamp, T5 Wedge Based (914)
B909	6V, 3.7 W Lamp, T5 Wedge Based (909)
B939	6V, 5.4 W Lamp, T5 Wedge Based (939)
B927	6V, 7.2 W Lamp, T5 Wedge Based (927)
BMR16	6V, 5 W Lamp, MR-16 Halogen
CAX6	6V, 6 W Lamp, CAX-6 Halogen
BELPL149	6V, 5.4 W Lamp, MR-24 For ELM2
BT82	6V, 6.63 W Lamp, Dbl Contact Bayonet (11-082)
B47	6.3V, 9 W Lamp, Single Contact Bayonet (47T3.25)
BGE90	13V, 7.5 W Lamp, DC Bayonet Lamp
B915	12V, 9 W Lamp, Miniature Wedge (915)
B912	12V, 12.8 W Lamp, Miniature Wedge (912)
P/N	DESCRIPTION
BF6T5	6 W Lamp, T5 Linear Fluorescent
BF8T5	8 W Lamp, T5 Linear Fluorescent
B7C7	120 VAC, 7 W Lamp, Candelabra Screw (7C7)
P/N	DESCRIPTION
BT65DC	120 VAC, 20 W Lamp, Dbl Contact Bayonet (20T6.5)
BT65S	120 VAC, 20 W Lamp, Intermediate Screw (20T6.5)
BT65SF	120 VAC, 20 W Lamp, Intermediate Screw, Frosted (20T6.5)
B25T10	120 VAC, 25 W Lamp, Medium Screw Base (25T10)
BT6	145V, 15 W Lamp, Candelabra Screw (15T6)

FLUORESCENT LAMPS for exit signs and emergency lighting.

P/N	DESCRIPTION
BPL5	120 VAC, 5 W Compact Fluorescent Lamp (PL5)
BPL7	120 VAC, 7 W Compact Fluorescent Lamp (PL7)
BPL9	120 VAC, 9 W Compact Fluorescent Lamp (PL9)

SEALED BEAM LAMPS for emergency lighting.

P/N	DESCRIPTION
B7613	6V, 8 W Sealed Beam Lamp
BH7555	12V, 8 W Halogen Sealed Beam Lamp
B4044	12V, 12 W Sealed Beam Lamp
B4446	12.8V, 25 W Sealed Beam Lamp

Brooks' LED RETROFIT KITS come complete with two LED lamps, two intermediate base adapters, two double contact base adapters, and two **DayGlo** lenses (for use on 120 VAC circuits only). Five-year warranty with 50,000-hour life expectancy. Pkg/2.
NOTE: Call the Sales Dept. for 277 VAC applications.

P/N	DESCRIPTION
BLRKITR	Red LED Retrofit Lamps w/ Bases
BLRKITG	Green LED Retrofit Lamps w/ Bases

Watt-Man™ RED LED RETROFIT EXIT SIGN LAMPS use only 1 W of energy. Lamps feature unbreakable polycarbonate construction, solid-state electronics, and surge protection. Five-year warranty with 50,000-hour life expectancy. 120 VAC.

P/N	DESCRIPTION	SIZE
WS1	Red LEDs w/ Candelabra Screw Base, Pkg/2	3 ³ / ₄ "
WS3	Red LEDs w/ Intermediate Screw Base, Pkg/2	3 ³ / ₄ "
WS7	Red LEDs w/ Fluorescent PL Base	3 ³ / ₄ "
SAS	Socket & Adapter Set Bayonet & Intermediate	
MBA	Intermediate-to-Medium Base Adapter	3 ⁴ / ₄ "





BACTPLUS In Use

EXIT AND EMERGENCY LIGHTING TEST EQUIPMENT

The **BACTPLUS BATTERY TESTER** features a high-impact ABS case with a rubber holster and high-contrast inverted blue screen. Designed to test the most common 6V (1.2 Ah–12 Ah) and 12V (1.2 Ah–100 Ah) lead acid batteries, it displays DC voltage and Ah capacity in seconds, and there are no confusing conversion rates to worry about. Other features include calibration control protection, reinforced input sockets, and max input voltage protection with warning LED. Will not deplete batteries.

P/N	DESCRIPTION
BACTPLUS	6V/12V Battery Tester

For exit sign and emergency light service testing, **Brooks'** line of **BATTERY ANALYZERS** also check charging circuitry. Equipped with leads.



BBA64

BBA612

BBLEADS

P/N	DESCRIPTION
BBA64	4V/6V Analyzer (Up to 24 Ah)
BBA612	6V/12V Analyzer (Up to 24 Ah)
BBAC	Compact Carry Case For Analyzer
BBLEADS	Replacement Leads For Brooks Battery Analyzers

The **NON-CONTACT VOLTAGE PROBE** is designed for safety and limited troubleshooting with its three-way voltage alert—beeps, lights, and vibrates. It uses a non-contact method of AC voltage testing and determines if AC voltage is present without touching wires or opening lock nuts. Totally insulated, the **Voltage Probe** has no exposed metal or conductive parts and is CAT IV rated 1000 VAC.

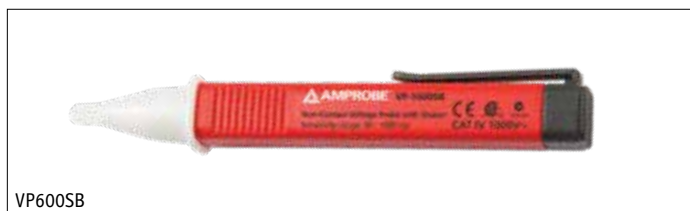

VP600SB

P/N	DESCRIPTION
VP600SB	Voltage Probe

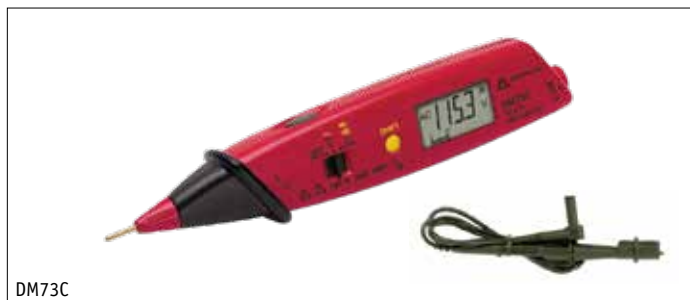

DM73C

Brooks' MULTI-METER measures both AC and DC current and determines continuity of lamps. It has a display-locking feature for added convenience.

P/N	DESCRIPTION
DM73C	Compact Multi-Meter



BPICK In Use

Hold down test buttons on exit and emergency lights with non-conductive plastic **EMERGENCY LIGHT TEST BUTTON PICKS** or with heavy-duty glass **STRAPPING TAPE**.

P/N	DESCRIPTION
BPICK	Test Button Picks, Pkg/275
GST	Strapping Tape, 1 7/8" x 12 yd

MISCELLANEOUS

The **Brooks EMERGENCY LIGHT PARTS TRAY** is ideal for organizing and carrying a wide variety of small emergency lighting parts. Manufactured from 18 ga epoxy-coated steel for superior durability and strength, it features a fold-away handle and seven storage compartments. White.

P/N	DESCRIPTION	H X W X D
ELT3	Emergency Light Parts Tray	5" x 15" x 10"



ELT3

The **Step 'N Store® TOOL BOX** is made of sturdy co-polymer that supports up to 325 lb. It comes with a sure-grip large carry handle, a handy tote tray, plus a deep-bottom storage area for supplies and tools. Lockable. Red.

P/N	DESCRIPTION	H X W X D
SSB20	Tool Box	12 1/2" x 20" x 14"



SSB20 In Use

LIGHTING SERVICE LABELS provide a service record for customers and local authorities. Available blank or with custom information, including company name, address, and phone number. Measures 3 1/2" x 1 3/4". Roll/100.

NOTE: Blank labels are sold by the roll; custom labels require a three-roll minimum order.

P/N	DESCRIPTION
ELTLBK	Emergency Lighting Test Labels, Blank
SSPELTL	Emergency Lighting Test Labels, Custom

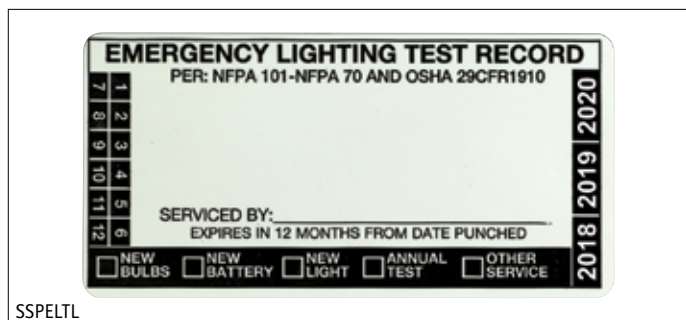

SSPELTL

Crescent® WIRE CUTTERS feature strong alloy tool steel with hardened cutting edges and nonslip cushion grips.

P/N	DESCRIPTION
TL0436	6" Wire Cutter

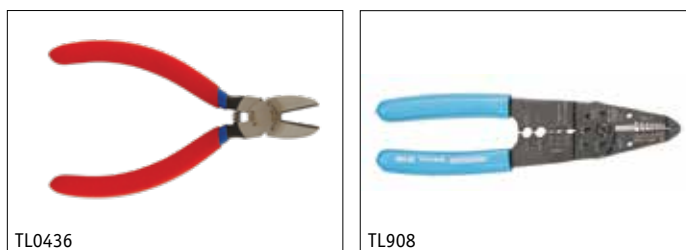

TL0436

TL908

This **WIRING TOOL** features heat-treated blades and **Channellock-Blue®** comfort grip handles.

P/N	DESCRIPTION
TL908	Wiring Tool

BATTERY LEADS

P/N	DESCRIPTION
UBL	Universal Battery Leads, Pkg/2
PBL	Plug Battery Lead

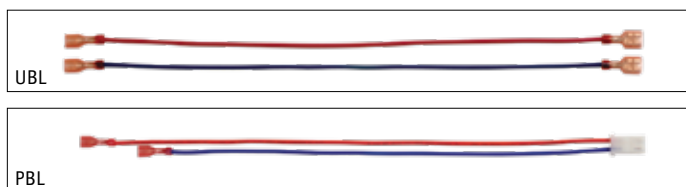

UBL

PBL

Standard twist-on and crimp-type wire **CONNECTORS**.

P/N	DESCRIPTION	PKG QTY
IFD16	Insulated Female Disconnect, 16/14 AWG Fits 3/4" Tab	50
IFD22	Insulated Female Disconnect, 22/18 AWG Fits 3/8" Tab	50
WC018	Orange Wire Connector, 18/14 AWG	100
VBS16	Vinyl Butt Splice, 16/14 AWG	50
WCG22	Gray Wire Connector, 22/18 AWG	100



IFD16

WCG22

WC018

VBS16

For Additional Tools, See Section 10.

In Use photos may show items not included or available separately.

EXIT AND EMERGENCY LIGHTING CROSS REFERENCE

EXIT SIGNS

P/N	BATTERY BACKUP	REPLACEMENT BATTERY	LIGHT SOURCE	REPLACEMENT LAMPS AC	REPLACEMENT LAMPS DC	UL LISTED	ETL LISTED
CHEX	Yes	Spec. Order	LED	Replace Unit	None	UL	-
CHEXST	Yes	Spec. Order	LED	Replace Unit	None	UL	-
EDGE1	Yes	BNP4700C	LED	Replace Unit	-	-	-
LEDAC	No	No Battery	LED	Replace Unit	-	UL	-
LED1	Yes	BNP4700C	LED	Replace Unit	-	UL	-
LED1B	Yes	BNP4700C	LED	Replace Unit	-	UL	-
LED2	Yes	BELB1201N	LED	Replace Unit	-	UL	-
LED4X	Yes	Spec. Order	LED	Replace Unit	-	UL	-
LED5	Yes	BNP4700C	LED	Replace Unit	-	-	ETL
LED6	Yes	BNP4700C	LED	Replace Unit	-	UL	-
LED10	Yes	Spec. Order	LED	Replace Unit	None	UL	-
LED10G	Yes	Spec. Order	LED	Replace Unit	None	UL	-
LED10SDT	Yes	Spec. Order	LED	Replace Unit	None	UL	-
NYLED1	Yes	BNP3700A	LED	Replace Unit	Spec. Order	UL	-
WETEXR1	Yes	BNP4700C	LED	Replace Unit	-	UL	-
WETEXR2	Yes	BNP4700C	LED	Replace Unit	-	UL	-

COMBINATION EXIT SIGNS

P/N	BATTERY BACKUP	REPLACEMENT BATTERY	LIGHT SOURCE	REPLACEMENT LAMPS AC	REPLACEMENT LAMPS DC EXIT	HEADS	UL LISTED	ETL LISTED
LED3*	Yes	PRB67	LED	Replace Unit	B909	B909	-	-
LED4SPRC	Yes	BNP8700AA	LED	Replace Unit	Spec. Order	Spec. Order	UL	-
LED4	Yes	PRB64	LED	Replace Unit	B909	B939	UL	-
LED4SDT	Yes	PRB67	LED	Replace Unit	B909	B939	UL	-
LED4MINI	Yes	Spec. Order	LED	Replace Unit	Replace Unit	Replace	UL	-
LED4B	Yes	PRB64	LED	Replace Unit	B939	B939	UL	-
LED4HO	Yes	2-PRB64	LED	Replace Unit	B939	B939	UL	-
LED4XCOMBO	Yes	BNP5400B	LED	Replace Unit	BMR16	BMR16	UL	-
LED7	Yes	PRB64	LED	Replace Unit	B909	B939	UL	-
NYLED4	Yes	PRB612	LED	Replace Unit	B939	B939	UL	-

*DISCONTINUED MODELS

EMERGENCY LIGHTS

P/N	BATTERY BACKUP	REPLACEMENT BATTERY	REPLACEMENT LAMPS	REMOTE LAMPHEAD CAPABILITY	UL LISTED	ETL LISTED
B12RL1459	Yes	2-PRB612-S	B4044	2-9RH or 1-11RH	UL	-
B12RL1859	Yes	3-PRB612-S	B4044	6-9RH or 3-11RH	UL	-
BELMLT	Yes	Spec. Order	Spec. Order	No	UL	-
BELR1	Yes	PRB64	B939	No	UL	-
BELR1B	Yes	PRB64	B939	No	UL	-
BELR1LED	Yes	BP700-3D	Replace Unit	No	UL	-
BELR1LEDSDT	Yes	BP700-3D	Replace Unit	No	UL	-
BELR2	Yes	PBR67	B939	2-8RH or 1-10RH	UL	-
BELR2LED	Yes	BP700-3D	Replace Unit	Yes	UL	ETL
BELR3	Yes	PRB64	B939	No	UL	-
BELR3B	Yes	PRB64	B939	No	UL	-
BELR4	Yes	2-PRB612-P	B927	6-8RH or 3-10RH	UL	-
BELR5	Yes	2-PRB612-S	B915	2-9RH or 1-11RH	UL	-
BLEDR1	Yes	Spec. Order	Spec. Order	No	UL	-
BNY62189	Yes	PRB67	Spec. Order	No	UL	-
BNY63279	Yes	PRB610	Spec. Order	No	UL	-
BNY123509	Yes	PRB610	B915	14W	UL	-
BTFX2	Yes	PRB64	B927	No	UL	-
BRMR16	Yes	PRB64	Spec. Order	No	UL	-
BRMR16LED	Yes	PRB64	Spec. Order	No	UL	-
BRL510	Yes	PRB612	B7613	1-8RH	UL	-
BREL4X	Yes	PBR67	BMR16	No	UL	-
CEW11	Yes	PRB64	None	No	UL	-
CHX	Yes	PRB612	Spec. Order	No	UL	-
ELM* (NEW)	Yes	PRB64	BELPL149	No	UL	-
ELM2* (NEW)	Yes	PRB64	BELPL149	No	UL	-
ELM2LED	Yes	Spec. Order	Replace Unit	No	UL	-
ELM4*	Yes	2-PRB612-S	B912	2-9RH or 1-11RH	UL	-
ELM1254	Yes	2-PRB612-S	B912	2-9RH or 1-11RH	UL	-
ELM627	Yes	PBR67	B927	2-8RH or 1-10RH	UL	-
EZ2	Yes	PRB64	B939	No	UL	-
LZ2*	Yes	PRB64	BMR16	No	UL	-
PRO2*	Yes	PRB64	B939	No	UL	-

*DISCONTINUED MODELS



39

SIGNS, LABELS, & TAGS

Sign Up With Brooks!



VINYL SIGNS (SELF-ADHESIVE)

SELF-ADHESIVE VINYL SIGNS and **LABELS** are silk screened with UV inks, then clear laminated for durability and fade resistance. Mounting surface must be clean, dry, smooth, and non-porous. To mount these on a porous surface, such as brick or concrete block, use our **Sign On!** aerosol adhesive.

ALUMINUM SIGNS

ALUMINUM SIGNS are silk screened, then oven baked for added durability. They have smooth finished edges, rounded corners, and pre-drilled holes for mounting. Ideal for porous surfaces, like concrete block or brick.

RIGID PLASTIC SIGNS

RIGID PLASTIC SIGNS are screen printed with UV inks on both sides. They are 1/32" thick and come with pre-drilled holes or keyhole slots for easy wall mounting.



FIRE EXTINGUISHER SIGNS

VINYL SIGNS

P/N	DESCRIPTION	L X H
BL107	"Fire Extinguisher" Arrow Sign, Vinyl	12" x 8"
BL108	"Fire Extinguisher" Arrow Sign, Vinyl	4" x 12"
BL109	"Fire Extinguisher" Arrow Sign, Vinyl	4" x 18"
BL109S	Spanish "Extintor" Arrow Sign, Vinyl	4" x 18"
BL114	"Fire Extinguisher" Arrow Sign, Vinyl	8" x 12"
BL120	"Fire Extinguisher" Sign, Vinyl	12" x 4 1/2"
BL127	Wrap Around Column or Pole "Fire Extinguisher" Arrow Sign, Vinyl	24 1/2" x 12 1/2"
BL132	"Extinguisher Missing" Sign, Vinyl	4" x 4"
BL189	K-Class "Fire Extinguisher" Arrow Sign, Vinyl, Bilingual	12" x 8"



ALUMINUM SIGNS

P/N	DESCRIPTION	L X H
A107	"Fire Extinguisher" Arrow Sign, Alum	12" x 8"
A108	"Fire Extinguisher" Arrow Sign, Alum	4" x 12"
A109	"Fire Extinguisher" Arrow Sign, Alum	4" x 18"
A114	"Fire Extinguisher" Arrow Sign, Alum	8" x 12"



RIGID PLASTIC SIGNS

P/N	DESCRIPTION	L X H
RP107	"Fire Extinguisher" Arrow Sign, Plastic	12" x 8"
RP108	"Fire Extinguisher" Arrow Sign, Plastic	4" x 12"
RP109	"Fire Extinguisher" Arrow Sign, Plastic	4" x 18"
RP114	"Fire Extinguisher" Arrow Sign, Plastic	8" x 12"
RP189	K-Class "Fire Extinguisher" Arrow Sign, Plastic, Bilingual	8" x 12"

ALUMINUM 90° ANGLE SIGNS

P/N	DESCRIPTION	L X H
AWM108	"Fire Extinguisher" 90° Arrow Sign, Alum	4" x 12"
AWM109	"Fire Extinguisher" 90° Arrow Sign, Alum	4" x 18"
AWM114	"Fire Extinguisher" 90° Arrow Sign, Alum	8" x 12"

RIGID PLASTIC 90° ANGLE SIGNS

P/N	DESCRIPTION	L X H
PWM108	"Fire Extinguisher" 90° Arrow Sign, Plastic	4" x 12"
PWM109	"Fire Extinguisher" 90° Arrow Sign, Plastic	4" x 18"
PWM114	"Fire Extinguisher" 90° Arrow Sign, Plastic	8" x 12"

3-D RIGID PLASTIC ANGLE SIGNS

P/N	DESCRIPTION	L X H
PTD108	"Fire Extinguisher" 3-D Arrow Sign, Plastic	4" x 12"
PTD109	"Fire Extinguisher" 3-D Arrow Sign, Plastic	4" x 18"
PTD182	"Fire Extinguisher" 3-D Arrow Sign, Plastic	5" x 6"
PTD109B	"Fire Extinguisher" 3-D Arrow Sign, Plastic, Bilingual	11" x 18"

FIRE EXTINGUISHER INSIDE SIGNS

VINYL SIGNS

P/N	DESCRIPTION	L X H
BL105	"Fire Extinguisher Inside" Sign, Vinyl	4" x 4"
BL116	"Fire Extinguisher Inside" Sign, Vinyl	6" x 9"
BL172	"Fire Extinguisher Inside" Sign, Vinyl	4" x 3"
BL183	"Fire Extinguisher Inside" Sign, Vinyl	18" x 2"

FIRE EXTINGUISHER CABINET SIGNS

VINYL SIGNS

P/N	DESCRIPTION	L X H
BL130	"In Case Of Fire Break..." Reversed Sign, Vinyl	4 ³ / ₄ " x 1 ¹ / ₂ "
BL123	"Warning \$500 Fine..." Sign, Vinyl	4" x 4"
BL131	"Warning \$1000 Fine..." Sign, Vinyl	4" x 4"
BL128	"Warning...Electronic Alarm" Sign, Vinyl	6" x 2"
BL106	"Fire Extinguisher-In Case Of Fire Break Glass", Sign, Vinyl	6" x 2"
BL135R	"Fire" Die-Cut Sign, Vinyl, Red	3" x 8 ¹ / ₂ "
BL135W*	"Fire" Die-Cut Sign, Vinyl, White	3" x 8 ¹ / ₂ "
BLM12*	"Pull Here..." Sign, Vinyl	4" x 2 ¹ / ₂ "

*WHILE QUANTITIES LAST!

SIGN ADHESIVE

Brooks' Sign On! SPRAY-ON ADHESIVE bonds signs to almost anything. 9.5 oz aerosol.

P/N	DESCRIPTION
BA1	Spray Adhesive

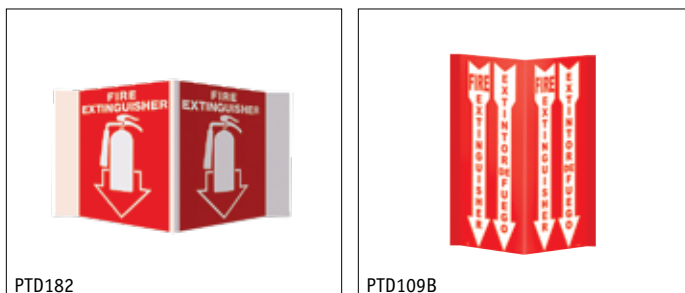

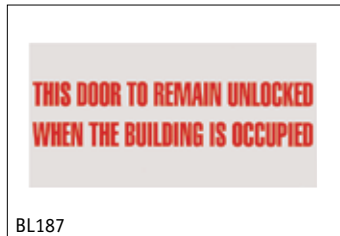

SMOKING SIGNS

VINYL SIGNS

P/N	DESCRIPTION	L X H
BL110	"No Smoking" Sign, Vinyl	12" x 4"
BL115	"No Smoking" Sign, Vinyl	8" x 10"
BL174	"No Smoking..." Sign w/Picture, Vinyl	8" x 5"

ALUMINUM SIGNS

P/N	DESCRIPTION	L X H
A115	"No Smoking" Sign w/ Picture, Alum	8" x 10"
A110	"No Smoking" Sign, Alum	12" x 4"

RIGID PLASTIC SIGNS

P/N	DESCRIPTION	L X H
RP115	"No Smoking" Sign w/ Picture, Plastic	8" x 10"
RP140*	"Danger No Smoking" Sign, Plastic	8" x 10"
RP194	"Smoking Permitted ..." Sign w/ Picture, Plastic	8" x 10"

*WHILE QUANTITIES LAST!

EXIT SIGNS AND DIRECTIONAL ARROWS

VINYL SIGNS

P/N	DESCRIPTION	L X H
BL112W	"Exit" Sign, White, Vinyl	12" x 8"
BL112	"Exit" Sign, Red, Vinyl	12" x 8"
BL126	"Not An Exit" Sign, Vinyl	10" x 9"
BL117	"In Case Of Fire...Use Stairways" Sign, Vinyl	5 1/2" x 7"
BL137	"This Door To Remain Unlocked..." Sign, Vinyl	23" x 17/8"
BL187	"This Door To Remain Unlocked..." Sign, Vinyl	12" x 6"
BL167	"Fire Door - Keep Closed" Sign, Vinyl	12" x 6"
BL168	"Emergency Exit Only" Sign, Vinyl	12" x 6"
BL169	"Emergency Exit Only..." Sign, Vinyl	12" x 6"
BL133	Directional Arrow Sign, Vinyl	4" Dia
BL113	Directional Arrow Sign, Vinyl	8" x 5"
BL121	Directional Arrow Sign, Vinyl	12" x 1 1/2"

ALUMINUM SIGN

P/N	DESCRIPTION	L X H
A112	"Exit" Sign, Alum	12" x 8"

RIGID PLASTIC SIGNS

P/N	DESCRIPTION	L X H
RP112	"Exit" Sign, Plastic	12" x 8"
RP117	"In Case Of Fire...Use Stairways" Sign, Plastic	5 1/2" x 7"

3-D RIGID PLASTIC ANGLE SIGN

P/N	DESCRIPTION	L X H
PTD112	"Exit" 3D Sign, Plastic	12" x 8"

FIRE HOSE SIGNS

VINYL SIGNS

P/N	DESCRIPTION	L X H
BL111	"Fire Hose" Sign, Vinyl	12" x 4"
BL118	"Fire Hose" Arrow Sign, Vinyl	8" x 12"
BL125	"Fire Hose" Arrow Sign, Vinyl	4" x 18"

PLASTIC 90° ANGLE SIGN

P/N	DESCRIPTION	L X H
PWM125	"Fire Hose" 90° Arrow Sign, Plastic	4" x 18"

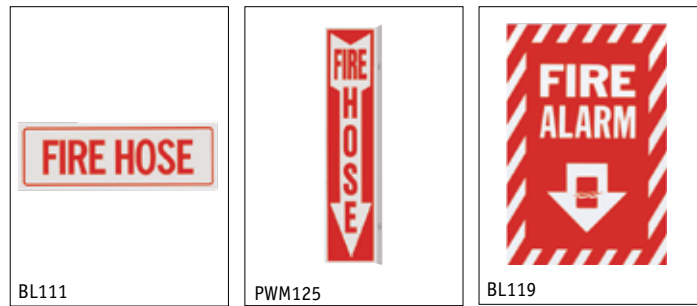

FIRE ALARM SIGNS

VINYL SIGNS

P/N	DESCRIPTION	L X H
BL119	"Fire Alarm" Arrow Sign, Vinyl	8" x 12"
BL185	"Fire Alarm Pull Station..." Sign, Vinyl	4" x 4"

3-D RIGID PLASTIC ANGLE SIGN

P/N	DESCRIPTION	L X H
PTD156	"Fire Alarm" 3D Arrow Sign, Plastic	4" x 12"



DANGER SIGNS

ANSI Z535 RIGID PLASTIC SIGNS

P/N	DESCRIPTION	L X H
RP139A	"Danger High Voltage" Sign, Plastic	7" x 10"
RP140A	"Danger No Smoking" Sign, Plastic	7" x 10"
RP146A	"Danger Flammable Materials" Sign, Plastic	7" x 10"
RP147A	"Danger Authorized..." Sign, Plastic	7" x 10"
RP148A	"Danger Construction..." Sign, Plastic	7" x 10"
RP150A	"Danger Flammable" Sign, Plastic	7" x 10"
RP152A	"Danger Keep Out" Sign, Plastic	7" x 10"

RIGID PLASTIC SIGNS

P/N	DESCRIPTION	L X H
RP140	"Danger No Smoking" Sign, Plastic	10" x 8"
RP145*	"Danger Safety Glasses" Sign, Plastic	10" x 8"
RP146*	"Danger Flammable Liquids" Sign, Plastic	10" x 8"
RP147*	"Danger Authorized ..." Sign, Plastic	10" x 8"
RP148*	"Danger Construction" Sign, Plastic	10" x 8"
RP151*	"Danger Hard Hat Area" Sign, Plastic	10" x 8"
RP152*	"Danger Keep Out" Sign, Plastic	10" x 8"
RP153*	"Danger Do Not Enter" Sign, Plastic	10" x 8"
RP154*	"Danger Ear Protection" Sign, Plastic	10" x 8"

*WHILE QUANTITIES LAST!



CAUTION SIGNS

ANSI Z535 RIGID PLASTIC SIGNS

P/N	DESCRIPTION	L X H
RP145A	"Caution Eye Protection..." Sign, Plastic	7" x 10"
RP151A	"Caution Hard Hat Required" Sign, Plastic	7" x 10"
RP154A	"Caution Hearing Protection..." Sign, Plastic	7" x 10"





FEPOSTER



FAPOSTER



103650BY In Use



BL170



RP176A



RP144A

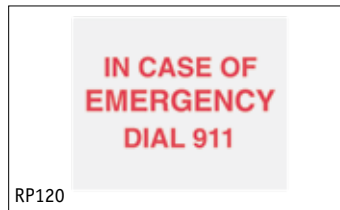

RP120



RP257



PTD176



G109



G112

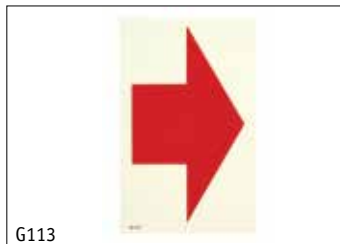

G113

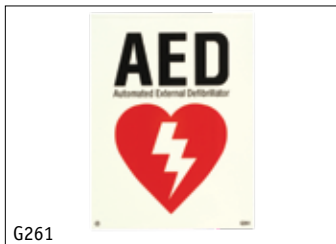

G261



G186

SAFETY TRAINING POSTERS

SAFETY TRAINING POSTERS provide concise, easy-to-understand explanations of key safety topics and their specific issues. All posters are laminated on both sides for extra durability.

P/N	DESCRIPTION	L X H
FEPOSTER	"Fire Extinguisher"	24" x 18"
FAPOSTER	"First Aid Training"	24" x 18"

MISCELLANEOUS SIGNS

The **HEIGHT INDICATOR** mounts next to door frames to help law enforcement determine a person's height. Durable vinyl reflective material is adhesive-backed for easy installation. Tape is 1 1/2" x 3' and marked from 4'-7'.

P/N	DESCRIPTION
103650BY	Height Indicator

VINYL SIGNS

P/N	DESCRIPTION	L X H
BL170	"Fire Blanket" Arrow Sign, Vinyl	4" x 18"
BL124	Hose Rack Operation Sign, Vinyl	13" x 2 3/4"

P/N	DESCRIPTION	L X H
BL144	"First Aid Station" Arrow Sign, Vinyl	8" x 12"

P/N	DESCRIPTION	L X H
BL157	"First Aid Kit Inside" Sign, Vinyl	4" x 4"

RIGID PLASTIC SIGNS

P/N	DESCRIPTION	L X H
RP176A	"Emergency Eye Wash..." ANSI Z535 Sign, Plastic	7" x 10"
RP120	"In Case of Emergency Dial 911" Sign, Plastic	8" x 10"
RP144*	"First Aid" Sign, Plastic	8" x 10"
RP144A	"Emergency First Aid" ANSI Z535 Sign, Plastic	7" x 10"
RP257	"For Use On Combustible..." Sign, Plastic	7" x 10"

*WHILE QUANTITIES LAST!

3-D RIGID PLASTIC ANGLE SIGNS

P/N	DESCRIPTION	L X H
PTD261	AED Stand-Out 3D Sign, Plastic	5" x 6"
PTD176	"Emergency Eye Wash..." 3D Sign, Plastic	18" x 10"

GLOW-IN-THE-DARK SIGNS

GLOW-IN-THE-DARK VINYL SIGNS will glow for up to eight hours, remaining very visible in normal lighting. Cycling from daylight to darkness will not wear out signs.

P/N	DESCRIPTION	L X H
G108	"Fire Extinguisher" Arrow Sign, Vinyl	4" x 12"
G109	"Fire Extinguisher" Arrow Sign, Vinyl	4" x 18"
G112	"Exit" Sign, Vinyl	12" x 8"
G113	Directional Arrow Sign, Vinyl	8" x 5"
G126	"No Exit" Sign, Vinyl	5" x 5 1/4"
G186	"Fire Extinguisher" Sign, Vinyl	6" x 1"
G261	AED Sign, Vinyl	6" x 8"

In Use photos may show items not included or available separately.

SYSTEM SIGNS

ALUMINUM SYSTEM SIGNS (adhesive backed).

P/N	DESCRIPTION	L X H
A106	"Caution..." Sign	5" x 2"
A106S	Spanish "Caution..." Sign	5" x 2"
A272	"Remote Pull Station..." Sign	5" x 3"
A273	"Fire System..." Sign	5" x 3"
A276	"Fryer" Sign	4" x 2"
A277	"Griddle" Sign	4" x 2"
A278	"Broiler" Sign	4" x 2"
A281	"Hood #1" Sign	4" x 2"
A282	"Hood #2" Sign	4" x 2"
A283	"Hood #3" Sign	4" x 2"
A284	"Hood #4" Sign	4" x 2"

SPRINKLER SIGNS

ALUMINUM SPRINKLER IDENTIFICATION SIGNS are painted white and printed with fade-resistant red ink. Each sign has pre-drilled mounting holes for easy installation.

P/N	DESCRIPTION	L X H
A142	"...Automatic Sprinkler..." Sign	6" x 4"
A143	"Control Valve" Sign	6" x 2"
A160	"Inspection Test" Sign	6" x 2"
A161	"Main Drain" Sign	6" x 2"
A162	"Sprinkler Control" Sign	6" x 2"
A163	"Alarm Test" Sign	6" x 2"
A164	"Hydraulic Data..." Sign	6" x 4"
A165	"Sprinkler Fire-Alarm..." Sign	7 ³ / ₄ " x 6"
A221♦	"Air Control" Sign	6" x 2"
A222♦	"Air Line" Sign	6" x 2"
A223♦	"Alarm Line" Sign	6" x 2"
A224♦	"Anti-Freeze System" Sign	6" x 2"
A225♦	"Auxiliary Drain" Sign	6" x 2"
A226♦	"This Valve Controls..." Sign	9" x 7"
A227♦	"Drain" Sign	6" x 2"
A228♦	"Drain Valve" Sign	6" x 2"
A229♦	"Dry Standpipe" Sign	6" x 2"
A232♦	"Hydraulic System..." Sign	5" x 7"
A233♦	"Main Control" Sign	6" x 2"
A234♦	"Normally Closed" Sign	6" x 2"
A235♦	"Normally Open" Sign	6" x 2"
A236♦	"Open Sprinkler Control" Sign	6" x 2"
A237♦	"Open Sprinkler Drain" Sign	6" x 2"
A238♦	"Sprinkler Valve Room" Sign	6" x 2"
A239♦	"Test & Drain" Sign	6" x 2"
A240♦	"Test Valve" Sign	6" x 2"
A241♦	"Water Motor Line" Sign	6" x 2"
A242♦	"Wet Standpipe" Sign	6" x 2"
A243♦	"Fire Sprinkler Valve" Sign	6" x 2"

♦ Plastic coated

PLASTIC SPRINKLER ALARM SIGN is painted red and printed with fade-resistant white ink. Pre-drilled for easy installation over an alarm bell.

P/N	DESCRIPTION	DIA
RP251	"Sprinkler Fire Alarm..." Sign	7"

These quality-made **ALUMINUM FDC SIGNS** help firefighters find water sources quickly. Signs come with pre-drilled holes for easy mounting.

P/N	DESCRIPTION	L X H
A244	"Fire Department Connection" Sign	4" x 6"
A245	"FDC" Sign w/ Arrow, 4" Letters	12" x 10"
A246	"FDC" Sign, 6" Letters	10" x 14"
RA246	"FDC" Sign, 6" Reflective Letters	7" x 14"

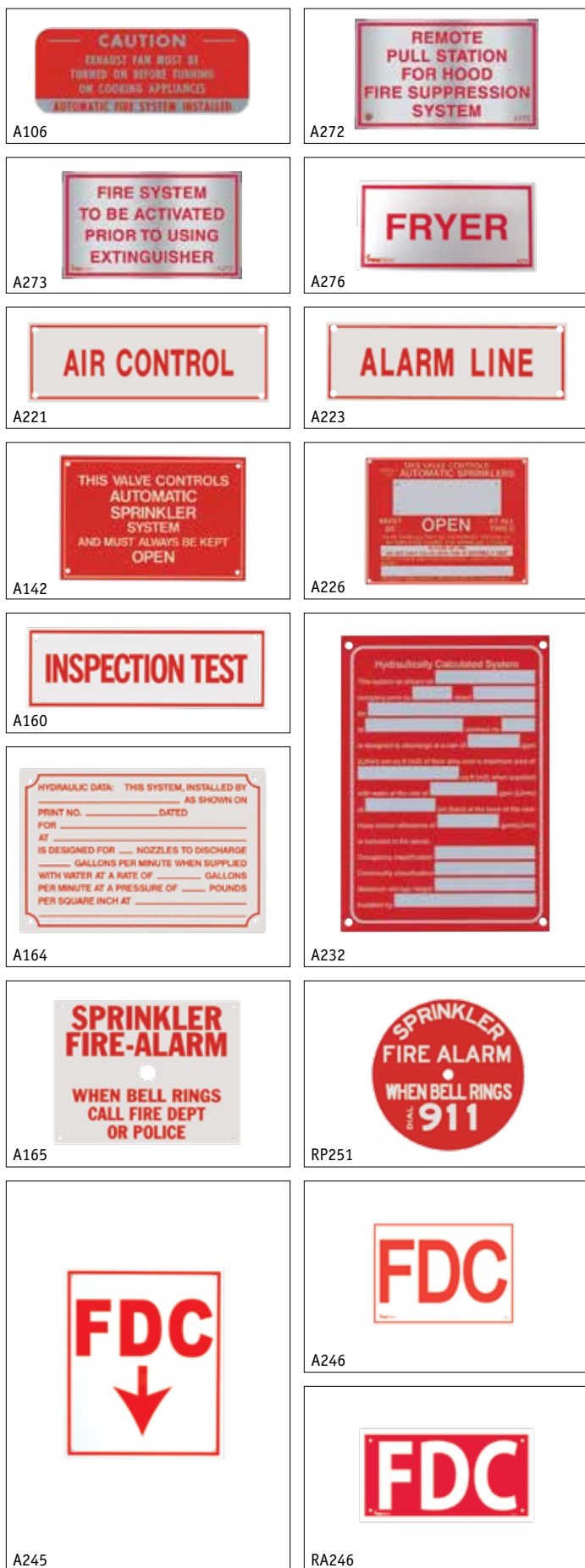

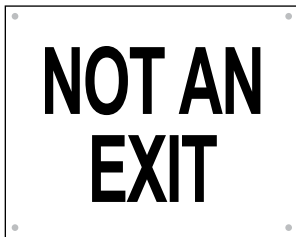

EXAMPLE #1

THIS DOOR TO REMAIN UNLOCKED
WHEN THE BUILDING IS OCCUPIED

EXAMPLE #2

FRYER #1

EXAMPLE #3



EXAMPLE #4

SPRINKLER
CONTROL

EXAMPLE #5

CUSTOM ENGRAVED SIGNS

Two exciting options available—**PLASTIC WITH PRE-PUNCHED HOLES** or **PLASTIC WITH ADHESIVE BACK**.

- Custom made to your specifications—up to 432 sq in.
- Seven different color schemes available.
- Comes complete with pre-punched corner holes or adhesive backs.
- Service your non-traditional sign needs with our custom signs up to (24" x 18").

EXAMPLES:

PLASTIC WITH PRE-PUNCHED HOLES



RED ON WHITE

PLASTIC WITH ADHESIVE BACK

System Serviced in Accordance with
NFPA17 or 17A and 96 by
ABC Fire Systems
(555) 555-5555

RED ON WHITE

REMOTE PULL FOR
HOOD #1

BLACK ON YELLOW



CORPORATE HEADQUARTERS
 P. O. Box 481888
 Charlotte, NC 28269
 www.BrooksEquipment.com

TELEPHONE
 800.826.3473 / 704.596.9438
FAX
 800.433.9265
EMAIL
 Sales@BrooksEquipment.com

CUSTOM ENGRAVED SIGNS EASY ORDER FORM

ORDERED BY	
Company Name	
Account #	
Purchase Order	
Ordered By	
Phone	Fax
Email	

SHIP TO		
Name		
Address		
Address		
City	State	Zip

DIRECTIONS

1 Check (✓) the orientation you want.

<input type="checkbox"/>		<input type="checkbox"/>	
	Portrait		Landscape

2 What dimensions do you want?

_____ "H _____ "W

Maximum Sign Size: 18"H x 24"W
 Minimum Size: 1"H x 2"W

3 Check (✓) the color you want.

<input type="checkbox"/> RED ON WHITE (RW)	<input type="checkbox"/> WHITE ON RED (WR)	<input type="checkbox"/> BLACK ON YELLOW (BKY)
<input type="checkbox"/> WHITE ON BLUE (WB)	<input type="checkbox"/> WHITE ON GREEN (WG)	<input type="checkbox"/> BLACK ON WHITE (BKW)
<input type="checkbox"/> WHITE ON BLACK (WBK)		

4 What do you want your sign to say?

H

W

If you have a special design or layout, draw it in the box.
 Not a designer? Let us do it for you at no extra charge! Call your Account Rep for more information. (High resolution image required).

5 Check (✓) the type of mounting you want.

<input type="checkbox"/> ADHESIVE BACKING	<input type="checkbox"/> CORNER HOLES

6 Add color code to part number(s) and insert quantities.

CUSTOM ENGRAVED SIGNS WITH PRE-PUNCHED CORNER HOLES

P/N	DESCRIPTION	QTY			
CS15_____	Custom Engraved Sign (up to 15 sq in)				
CS30_____	Custom Engraved Sign (up to 30 sq in)				
CS96_____	Custom Engraved Sign (up to 96 sq in)				
CS144_____	Custom Engraved Sign (up to 144 sq in)				
CS228_____	Custom Engraved Sign (up to 228 sq in)				
CS432_____	Custom Engraved Sign (up to 432 sq in)				

CUSTOM ENGRAVED SIGNS WITH FOAM ADHESIVE BACKING

P/N	DESCRIPTION	QTY			
CS15_____A	Custom Engraved Sign (up to 15 sq in)				
CS30_____A	Custom Engraved Sign (up to 30 sq in)				
CS96_____A	Custom Engraved Sign (up to 96 sq in)				
CS144_____A	Custom Engraved Sign (up to 144 sq in)				
CS228_____A	Custom Engraved Sign (up to 228 sq in)				
CS432_____A	Custom Engraved Sign (up to 432 sq in)				

**PHOTOCOPY THIS FORM AND FAX TO 800.433.9265
 OR VISIT WWW.BROOKSEQUIPMENT.COM**

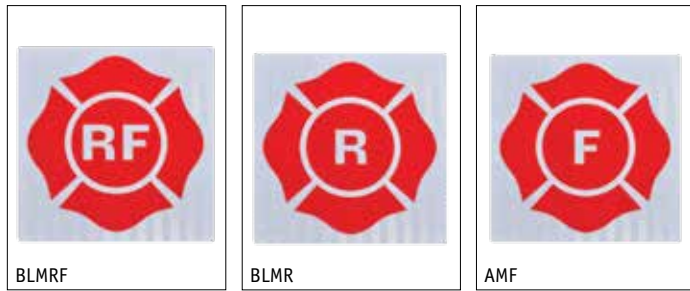

FLORIDA TRUSS SIGNS, from **Brooks**, are made of engineer-grade prismatic material and are available in 0.040 aluminum with radius corners and four mounting holes or vinyl peel and stick. Measuring 9" x 9", with the compliant 8" x 8" Maltese symbol, these signs are designed to comply with the requirements of Rule 69A-60.0081 of the Florida Fire Prevention Code. This rule requires that any structure that uses light-frame, truss-type construction be marked with an approved symbol.

P/N	DESCRIPTION
AMR	"R" (Roof) Sign, Alum
AMRF	"RF" (Roof/Floor) Sign, Alum
AMF	"F" (Floor) Sign, Alum
BLMR	"R" (Roof) Sign, Vinyl
BLMRF	"RF" (Roof/Floor) Sign, Vinyl
BLMF	"F" (Floor) Sign, Vinyl



NUMBER KIT

The self-adhesive vinyl **NUMBER KIT** includes 25 each of numbers 0–9, measuring 1" x 5/8" with a 1/8" border (top and bottom), and comes in a sturdy 10-compartment plastic storage box. Numbers can be ordered individually.

P/N	DESCRIPTION
BLKIT	Number Kit
BL__	Individual Numbers, 0–9

Add Number to Blank to Order

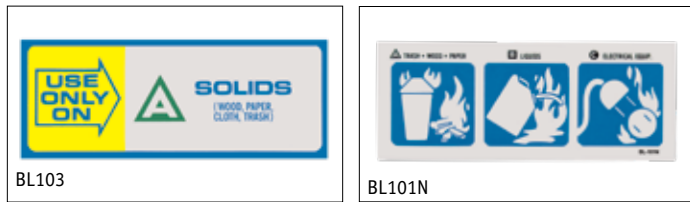

EXTINGUISHER OPERATING LABELS

Self-adhesive vinyl **FIRE CLASSIFICATION LABELS**.

P/N	DESCRIPTION	L X H
BL101	"Use On All Fires-ABC" Label	4 1/2" x 1 3/4"
BL102	"Use Only On-BC" Label	4 1/2" x 1 3/4"
BL103	"Use Only On-A" Label	4 1/2" x 1 3/4"
BL101N	"ABC" Pictorial Label	4 1/2" x 1 3/4"
BL102N	"BC" Pictorial Label	3" x 1 3/4"
BL103N	"A" Pictorial Label	4 1/2" x 1 3/4"



Self-adhesive vinyl **PICTORIAL OPERATING LABEL**.

P/N	DESCRIPTION	L X H
BL122	Extinguisher Instruction Label	5 1/2" x 2 1/2"



Self-adhesive vinyl **PICTORIAL OPERATING LABELS** for ABC and BC fire extinguishers.

P/N	DESCRIPTION	L X H
BL200	ABC Extinguisher w/ Hose Instruction Label	3" x 5 1/4"
BL201	ABC Extinguisher w/ Nozzle Instruction Label	3" x 5 1/4"
BL202	BC Extinguisher w/ Hose Instruction Label	3" x 5 1/4"
BL203	BC Extinguisher w/ Nozzle Instruction Label	3" x 5 1/4"

Self-adhesive vinyl **PICTORIAL OPERATING LABELS** for water and CO₂ fire extinguishers.

P/N	DESCRIPTION	L X H
BL204	Water Extinguisher Instruction Label	3" x 5 1/4"
BL206	CO ₂ Extinguisher Instruction Label	3" x 5 1/4"

Self-adhesive vinyl **PICTORIAL OPERATING LABELS** for cartridge-operated ABC and BC fire extinguishers.

P/N	DESCRIPTION	L X H
BL207	ABC Cartridge Extinguisher Instruction Label	3" x 5 1/4"
BL208	BC Cartridge Extinguisher Instruction Label	3" x 5 1/4"

Self-adhesive vinyl **PICTORIAL OPERATING LABELS** for CO₂ fire extinguishers.

P/N	DESCRIPTION	L X H
BL209	5 lb CO ₂ Extinguisher Instruction Label	5" x 5 1/2"
BL210	Larger CO ₂ Extinguisher Instruction Label	5" x 5 1/2"

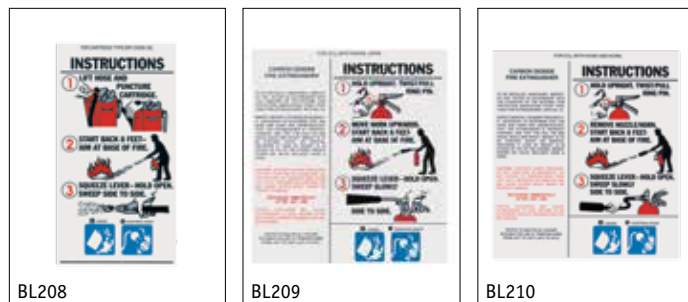
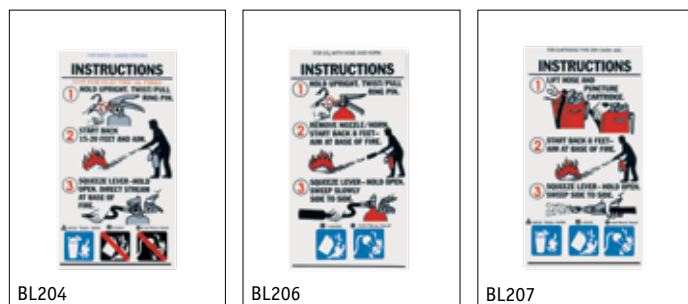

DOT LABELS

DEPARTMENT OF TRANSPORTATION COMPRESSED GAS LABEL (per DOT 49CFR, section 172.400A) features self-adhesive, heavy-duty material with tough fade-resistant ink that will not come off with normal cleaning compounds.

P/N	DESCRIPTION	L X H
BL173	"Carbon Dioxide UN 1013" Label	5 7/8" x 2 1/4"



DEPARTMENT OF TRANSPORTATION LABELS

P/N	DESCRIPTION	L X H
BL177	"Nitrogen Compressed UN 1066" Label	5 3/4" x 2 1/4"
BL178	"Halon 1211 & Nitrogen UN 1956" Label	5 3/4" x 2 1/4"



DEPARTMENT OF TRANSPORTATION LABELS

P/N	DESCRIPTION	L X H
BL179	"Halon 1301 & Nitrogen UN 1956" Label	5 7/8" x 2 1/4"
BL180	"Compressed Air UN 1002" Label	5 7/8" x 2 1/4"

DEPARTMENT OF TRANSPORTATION LABELS

P/N	DESCRIPTION	L X H
BL181	"Oxygen UN 1072" Label	5 3/4" x 2 1/4"
BL184	"Carbon Dioxide UN 1013" Label	3 3/8" x 2"
BL191	"Halotron & Argon UN 1956" Label	5 3/4" x 2 1/4"
BL192	"FE36 & Nitrogen UN 1956" Label	5 3/4" x 2 1/4"





BL171

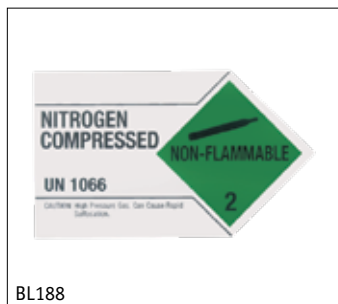

BL188

"NON-FLAMMABLE GAS" DOT SHIPPING LABELS

(paper). Roll/500.

P/N	DESCRIPTION	L X H
BL171	"Non-Flammable Gas" Labels	4" x 4"
BL171FE	"Non-Flammable Gas UN 1044" Labels	4" x 4 3/4"

DEPARTMENT OF TRANSPORTATION LABEL

P/N	DESCRIPTION	L X H
BL188	"Nitrogen Compressed UN 1066" Label	3 3/8" x 2"



BL44

Identify limited quantity shipments of dangerous goods (shipped by ground, rail, or sea) with **BLANK LIMITED QUANTITY MARKINGS**. These paper markings can be used on certain shipments of limited-quantity dangerous goods instead of the proper shipping name (per the DOT). They are designed to catch the eye of personnel who come within range of your shipments. Complies with 49CFR, section 172.315. 4" x 4". Black/White. Roll/500.

P/N	DESCRIPTION
BL44	Limited Quantity Markings

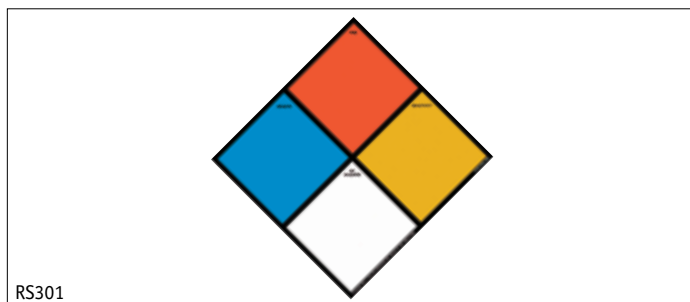

RS301

NFPA HAZARD IDENTIFICATION DIAMONDS come in two sizes: 10" and 16" square polystyrene. They are designed to help meet hazcom/NFPA 704 requirements with color coding to indicate fire, health, instability (reactivity), and special hazards. The **NUMBER/SYMBOL KIT** (for 10" sign) includes three each of numerals 0, 1, 2, 3, 4 and one each of symbols for Oxidizer, Use No Water, Corrosive, and Radioactive. (The minimum size of numerals and symbols must be 3" for legibility at 100'.) Black.

P/N	DESCRIPTION
RS301	NFPA 10" Hazard Identification Sign
RS302	NFPA 16" Hazard Identification Sign
HAZN04	3" Numeral/Symbol Kit
HAZN07	6" Numeral/Symbol Kit



SSPHMCL1



SSPHMCL1

CUSTOM HAZMAT LABELS

Custom vinyl **HAZARDOUS MATERIAL COMMUNICATION LABELS** meet NFPA 10 requirements and come imprinted with your company name, address, and phone number. Minimum \$35 order and 100 each per copy.

NOTE: Do not install on front of extinguisher, per NFPA 10.

P/N	DESCRIPTION	L X H
SSPHMCL1	ABC HazMat Labels	2 3/4" x 2 1/2"
SSPHMCL2	BC HazMat Labels	2 3/4" x 2 1/2"
SSPHMCL3	CO ₂ HazMat Labels	2 3/4" x 2 1/2"
SSPHMCL4	Halon HazMat Labels	2 3/4" x 2 1/2"
SSPHMCL5	Water HazMat Labels	2 3/4" x 2 1/2"
SSPHMCL9	Custom HazMat Labels	2 3/4" x 2 1/2"

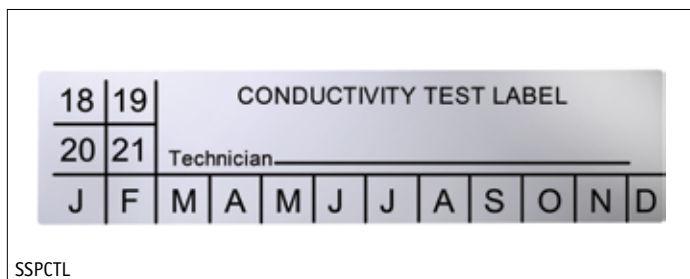

SSPCTL

Custom-imprinted metallic **CONDUCTIVITY TEST LABELS** have a single line imprint area. Roll/300 (two-roll minimum).

P/N	DESCRIPTION	L X H
SSPCTL	Custom Conductivity Test Labels	3" x 3/4"
CTLBK	Blank Conductivity Test Labels (No Min Order)	3" x 3/4"

CUSTOM HYDROSTATIC TEST/6-YEAR LABELS

HYDROSTATIC TEST and **6-YEAR MAINTENANCE LABELS** are a necessary reminder to keep your customer's equipment maintenance and inspections up to date. And they can be custom imprinted with your company name, address, and phone number in your choice of white or blue vinyl or silver metallic (shows "Void" when removed—as recommended in NFPA 10). Roll/100 (10 roll minimum order for vinyl labels; 5 roll minimum order for metallic labels—priced per roll). Delivery is 4–6 weeks.

P/N	DESCRIPTION	L X H
SSPVHT	Low-Pressure Hydrostatic Test Labels, White Vinyl	3 1/2" x 2 1/4"
SSPV6H	Standard Hydrostatic Test Labels, White Vinyl	3 1/2" x 2 1/4"
SSPVCA	California Hydrostatic Test Labels, White Vinyl	3 1/4" x 2 1/4"
SSPBL6	6-Year Maintenance Labels, Blue Vinyl	3 1/2" x 2 1/4"



SSPVHT

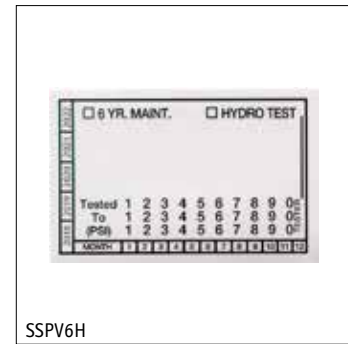

SSPV6H



SSPVCA



SSPBL6

Custom **HYDROSTATIC TEST** and **6-YEAR MAINTENANCE METALIZED LABELS.**

P/N	DESCRIPTION	L X H
SSPLPHTL	Low-Pressure Hydrostatic Test Labels, Silver Metallic	3 1/2" x 2 1/4"
SSPHTLCA	California Hydrostatic Test Labels	3 1/4" x 2 1/4"
SSPHTLCADOT	California DOT Hydrostatic Test Labels	3 1/4" x 2 1/4"
SSP6YR	6-Year Maintenance Labels	3 1/2" x 2 1/4"
SSP6HTL	Standard Hydrostatic Test Labels	3 1/2" x 2 1/4"
SSPM6HTL	Standard Hydrostatic Test Labels, Matte Finish	3 1/2" x 2 1/4"



SSPLPHTL



SSPHTLCA

BLANK HYDROSTATIC TEST/6-YEAR LABELS are silver "Void" metalized material. Stamp your own name (with permanent ink). Roll/250.

P/N	DESCRIPTION	L X H
6HTLTK	Blank Hydrostatic Test Labels, Silver Metallic	3 1/2" x 2 1/4"



SSP6YR



SSPHTLCADOT

COMPOSITE CYLINDER TEST LABELS are for recording test information on composite cylinders, per DOT 49CFR, section 180.213. Instructions provided. Roll/50.

P/N	DESCRIPTION	L X H
CRL50	Composite Retest Labels	2" x 1 1/4"

FIVE-MINUTE EPOXY for applying over the **Composite Test Labels.** 1 oz.

P/N	DESCRIPTION
5ME	5-Minute Epoxy



CRL50



5ME

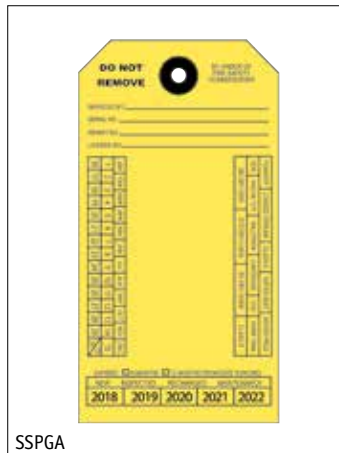
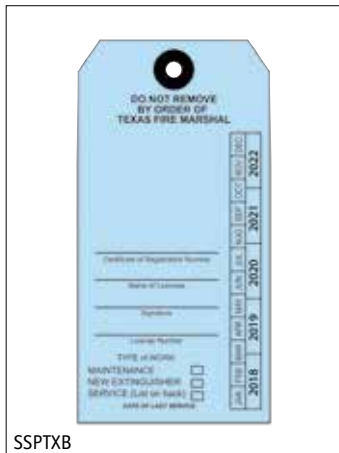
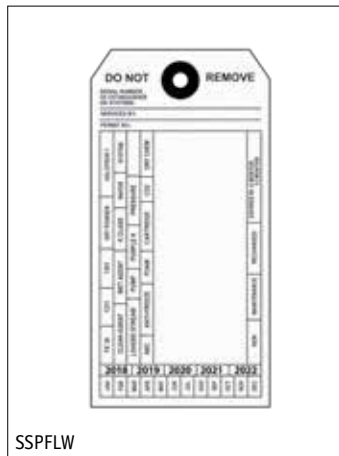

CUSTOM SERVICE TAGS

Custom-imprinted extinguisher **SERVICE TAGS** are printed on both sides of coated 13-pt stock with reinforced eyelets. **Final proof due every 10th and 25th of each month** with delivery in 6–8 weeks. Colors available: Yellow (Y), Orange (O), Blue (B), Green (G), Red (R), Lilac (L), and White (W). Call Sales for pricing on large orders, special designs, and our custom stocking program.

NOTE: It is the customer's responsibility to be sure the tag design meets all local and state regulations. SSPRUSH 3 and 5 are not available for Tyvek® tags.

P/N	DESCRIPTION
SSPPL	Plate Charge <i>New & Revised Orders Only</i>
SSPSU	Setup Charge <i>For Each Order</i>
SSPME	Metal Eyelets Add-On
SSPWIRE	Wire Attachment Add-On
SSP2CO	Two Ink Color Add-On
SSP3CO	Three Ink Color Add-On
SSPTVK	Tyvek Add-On, White Only
SSPTVKWIRE	Tyvek Wire Attachment Add-On
SSPFLU	Fluorescent Add-On <i>No Rush Delivery</i>
SSPRUSH	Rush Charge, 2–3 Week Print Time (Max 10,000)
SSPRUSH5	Rush, 5 Day Print Time (Max 10,000)
SSPRUSH3	Rush, 3 Day Print Time (Max 10,000)

Custom-imprinted **STANDARD SERVICE TAGS** have a minimum order of 2000. See above for additional options and color codes. Pkg/1000.

P/N	DESCRIPTION	L X H
SSPST_	Custom Service Tags <i>Add Color Code to Blank to Order</i>	2 ⁵ / ₈ " x 5 ¹ / ₄ "

Custom-imprinted **SERVICE TAGS** have a minimum order of 2000. See above for additional options and color codes. Pkg/1000. **NOTE:** Red not permitted in Texas!

P/N	DESCRIPTION	L X H
SSPFL_	Custom Florida Tags <i>Add Color Code to Blank to Order</i>	2 ⁵ / ₈ " x 5 ¹ / ₄ "
SSPTX_	Custom Texas Tags <i>Add Color Code to Blank to Order</i>	2 ⁵ / ₈ " x 5 ¹ / ₄ "
SSPGA	Custom Georgia Tags, Yellow	3" x 5 ³ / ₄ "
SSPGAB	Custom Georgia Tags, Light Blue	3" x 5 ³ / ₄ "
SSPLTAG	Custom Louisiana Tags, Light Green	2 ⁵ / ₈ " x 5 ¹ / ₄ "
SSPLTAGB	Custom Louisiana Tags, Light Blue	2 ⁵ / ₈ " x 5 ¹ / ₄ "

Custom-imprinted **ILLINOIS SERVICE TAGS** have a minimum order of 2000. See above for additional options. Light Green. Pkg/1000.

P/N	DESCRIPTION	L X H
SSPILG	Custom 2018 Illinois Tags	2 ⁵ / ₈ " x 5 ¹ / ₄ "

Custom-imprinted **CALIFORNIA SERVICE TAGS** have a minimum order of 2000. See above for additional options and color codes. Pkg/1000. **NOTE:** Red not permitted in California!

P/N	DESCRIPTION	L X H
SSPCA_	Custom California Tags <i>Add Color Code to Blank to Order</i>	2 ⁵ / ₈ " x 4 ³ / ₄ "
SSPCAFSTAG	Custom CA Fixed Systems Tags, White	2 ⁵ / ₈ " x 5 ¹ / ₄ "

Custom-imprinted **"N"-STYLE SERVICE TAG** has a minimum order of 2000. See page 178 for additional options and color codes. Pkg/1000.

P/N	DESCRIPTION	L X H
SSPNF_	Custom "N"-Style Tags	2 ⁵ / ₈ " x 5 ¹ / ₄ "
	Add Color Code to Blank to Order	

BLANK SERVICE TAGS

BLANK SERVICE TAGS. Pkg/100.

P/N	DESCRIPTION	L X H
STAGBK	Blank Standard Tags, Yellow	2 ⁵ / ₈ " x 5 ¹ / ₄ "
GATAGBK	Blank Georgia Tags, Yellow	3" x 5 ³ / ₄ "
GABTAGBK	Blank Georgia Tags, Light Blue	3" x 5 ³ / ₄ "
LGTAGBK	Blank Louisiana Tags, Light Green	2 ⁵ / ₈ " x 5 ¹ / ₄ "
TXTAGBK	Blank Texas Tags, White	2 ⁵ / ₈ " x 5 ¹ / ₄ "
ILTAGBK	Blank Illinois Tags, Light Green	2 ⁵ / ₈ " x 5 ¹ / ₄ "
NFWBK	Blank "N"-Style Tags, White	2 ⁵ / ₈ " x 5 ¹ / ₄ "



SSPNFW

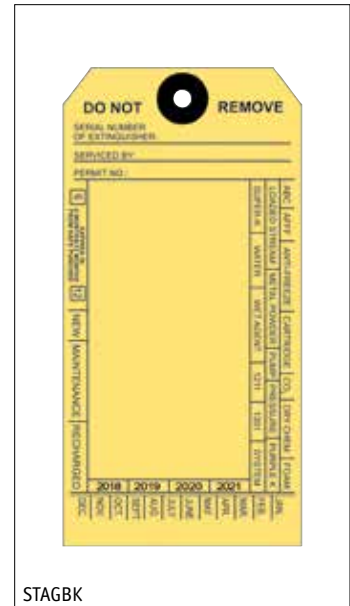

STAGBK

CUSTOM STAMPS AND ACCESSORIES

Custom-imprinted **SELF-INKING STAMP KITS** come complete with everything you need—stamp, ink, and dry cartridge—to easily stamp standard or coated cardstock. Stamps feature clear windows for accurate positioning as well as replaceable ink cartridges.

STAMP1 offers 2500 impressions and **STAMP2** 8000 impressions per bottle of ink. A signed proof is required before order will be processed. Allow one week for delivery.

P/N	DESCRIPTION
CUSTOMSTAMP1	Custom Stamp, 1 ¹ / ₂ " x 3"
CUSTOMSTAMP2	Custom Stamp, 3/4" x 1 ⁷ / ₈ "
STAMP1HOUSING	Replacement Housing (STAMP1)
STAMP2HOUSING	Replacement Housing (STAMP2)
DIC1	Dry Ink Cartridge (STAMP1)
DIC2	Dry Ink Cartridge (STAMP2)
BTI	Black Textile Ink, 2 oz



CUSTOMSTAMP1



CUSTOMSTAMP2 In Use

CUSTOM SERVICE AND INSTALLATION LABELS

Custom vinyl **SERVICE LABELS** can be printed with your design or our standard one in fade-resistant black ink on white vinyl. Roll/1000.

P/N	DESCRIPTION	L X H
SSPVSTAG	Custom Service Labels	2 ⁵ / ₈ " x 5 ¹ / ₄ "
SSPCSTAG	Custom Design Labels	2 ⁵ / ₈ " x 5 ¹ / ₄ "
SSPCACS	Custom CA Service Labels	2 ⁵ / ₈ " x 5 ¹ / ₄ "
SSPCASYS	Custom CA Mandated Systems Labels	2 ⁵ / ₈ " x 5 ¹ / ₄ "
SSPCANFPA25	Custom CA NFPA Sprinkler Labels	2 ⁵ / ₈ " x 5 ¹ / ₄ "
SSPFLTAG	Custom FL Service Labels	2 ⁵ / ₈ " x 5 ¹ / ₄ "

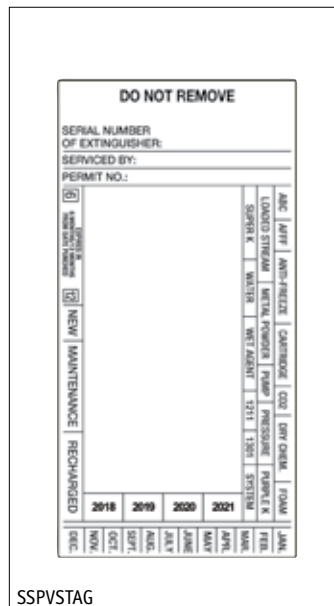

SSPVSTAG

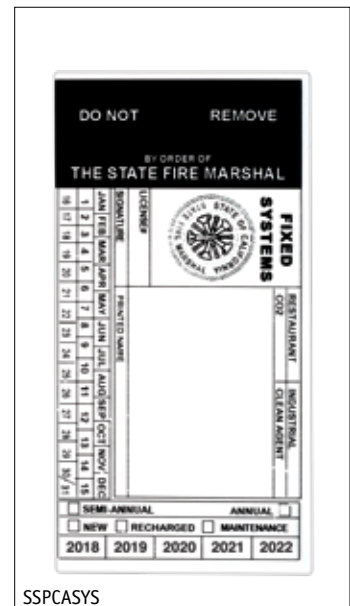

SSPCASYS

In Use photos may show items not included or available separately.



SSPFSL



SSPFSL

Custom **"CALL FOR SERVICE" LABELS** are printed with your company name and phone number and feature white polyvinyl with red/yellow borders and black imprint. Ideal for extinguishers, hoods, first aid kits, hose stations, etc. Roll/500.

P/N	DESCRIPTION	L X H
SSPFSL	"Call for Service" Labels	3 1/4" x 2"

Imprinted vinyl **INSTALLATION LABELS** are for automatic systems and alarm panels. Roll/100.



LAIL100



LAIL100

P/N	DESCRIPTION	L X H
LAIL100	Louisiana Installation Labels	3 7/8" x 3 7/8"
TXIL100	Texas Installation Labels	5" x 4"
OKIL100	Oklahoma Installation Labels	5" x 4"

AGENT REPLACEMENT LABELS are used to record agent replacement, as required by NFPA 10, sections 7.7.2.3.1 (Foam), 7.7.2.2 (Wetting Agent), and 7.7.3.11 (Wet Chemical). Made of the same material as our **Continuity Test Labels** (silver metallic), they come preprinted with a four-year record. Roll/300.

P/N	DESCRIPTION	L X H
ARL300	Agent Replacement Labels	3" x 3/4"



ARL300

VERIFICATION OF SERVICE COLLARS (BLANK AND CUSTOM)

Blank **VERIFICATION OF SERVICE COLLARS** are made of durable polymer material and come in four different sizes and colors with molded years (two smallest sizes have two years; larger ones have four).

NOTE: Collars read, "Verification of Service, YR ____-____" and "MN 1-12".

P/N	DESCRIPTION	PKG QTY	ID
SC1	Blank Collars, Green	100	1 3/8"
SC2	Blank Collars, Gray	100	1 3/4"
SC3	Blank Collars, Blue	50	2 1/8"
SC4	Blank Collars, Violet	50	3 1/16"

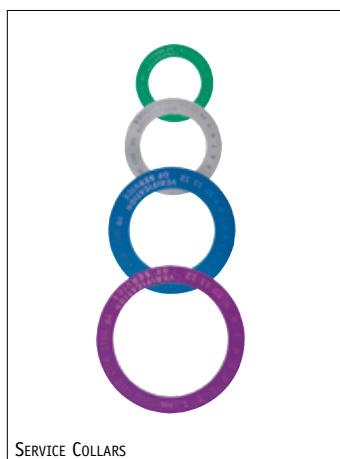

SERVICE COLLARS



SC1

Custom-imprinted **VERIFICATION OF SERVICE COLLARS** comply with NFPA 10 and are made of high-density polyethylene with clear polyester over lamination. They are available in four sizes with your company name and phone number imprinted in durable colored ink on white backgrounds. Other custom imprints available (as required by state). Normal delivery is 2-4 weeks. \$35 minimum order.

NOTE: Collars are approved for the State of Georgia.

P/N	DESCRIPTION	PKG QTY	ID
SSPCC1	Custom Collars, Green	100	1 3/8"
SSPCC2	Custom Collars, Gray	100	1 3/4"
SSPCC3	Custom Collars, Blue	100	2 1/8"
SSPCC4	Custom Collars, Violet	100	3 1/16"

Custom-imprinted **CALIFORNIA VERIFICATION OF SERVICE COLLARS** meet California State requirements and have the same specifications and order requirements as our **Custom-Imprinted Verification of Service Collars** (above).

NOTE: Company name and E# are required on CA collars.

P/N	DESCRIPTION	PKG QTY	ID
SSPCCAL1	Custom CA Collars, Green	100	1 3/8"
SSPCCAL2	Custom CA Collars, Gray	100	1 3/4"
SSPCCAL3	Custom CA Collars, Blue	100	2 1/8"
SSPCCAL4	Custom CA Collars, Violet	100	3 1/16"

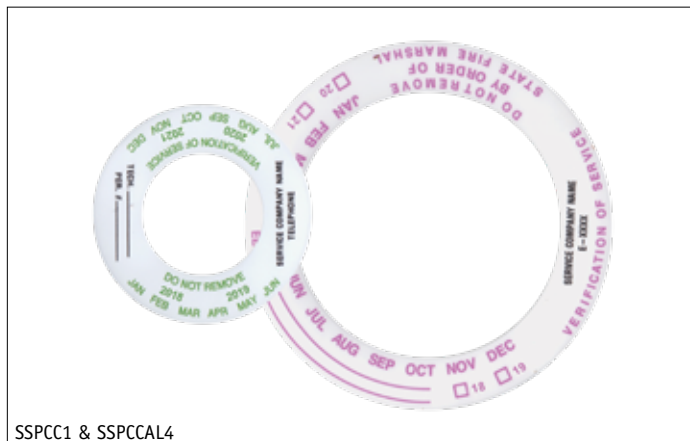

SSPCC1 & SSPCCAL4

MISCELLANEOUS TAGS

CUSTOMER REPAIR TAGS allow you to document the work performed on each extinguisher and the total amount to be paid. They come with looped strings for easy attachment around gauges and claim checks that are perforated for easy removal. Pkg/100.

P/N	DESCRIPTION	L X H
CRTAG	Customer Repair Tags	3 1/8" x 5 1/2"

Blank **TEXAS IMPAIRED TAGS** are designed for use with portable extinguishers and systems, per Texas code. Red with black imprint. Pkg/100.

P/N	DESCRIPTION	L X H
REDTXBK	Texas Impaired Tags	2 7/8" x 5 1/4"

NON-COMPLIANCE TAGS are for recording deficiencies in fire equipment. These two-part carbon forms come with paper fronts and heavy red stock backings. Meets State of Georgia code. Pkg/50.

P/N	DESCRIPTION	L X H
TNC50	Non-Compliance Tags	3 1/8" x 6 1/4"

The **CONDEMNED TAG** is for extinguishers that need to be removed from service. Red (as required by many states).

P/N	DESCRIPTION	L X H
ECTAG	Condemned Tag	5 1/4" x 2 3/4"

Perforated **CYLINDER TAGS** show whether cylinders are empty, in use, or full and come with fiber patches and wires. White. Pkg/50.

P/N	DESCRIPTION	L X H
3PCT	Cylinder Tags	2 5/8" x 5 1/4"

AED INSPECTION TAGS. White with red print. Pkg/100.

P/N	DESCRIPTION	L X H
AEDTAGBK	AED Inspection Tags	2 5/8" x 5 1/4"

This plastic 3-year monthly **INSPECTION & RECHARGE TAG** is designed for recording service and inspection dates—all on one tag. Printed in black and red ink on plastic stock, its back side is printed with a 12-month record (up to four years).

P/N	DESCRIPTION	L X H
ITAG	Inspection & Recharge Tag	2 13/16" x 5"

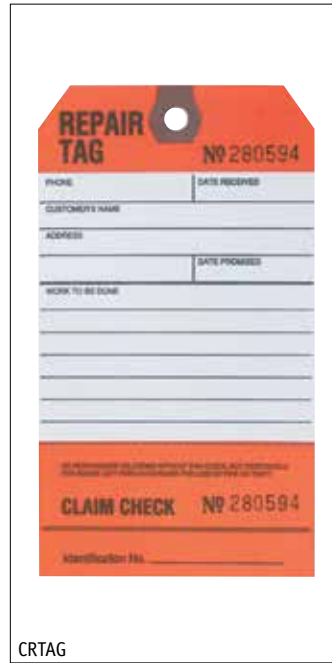

CRTAG

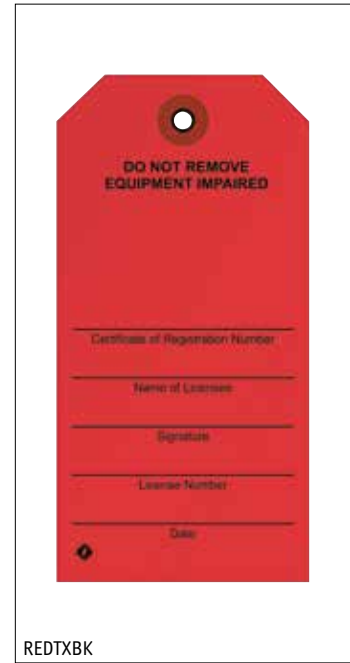

REDTXBK



TNC50

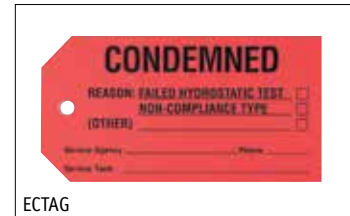

ECTAG



3PCT



AEDTAGBK



ITAG



TAG

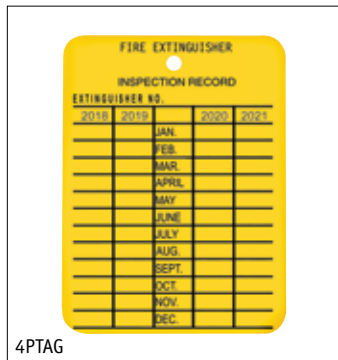

4PTAG

The **METAL 4-YEAR INSPECTION TAG** is designed to record monthly inspections of fire extinguishers.

P/N	DESCRIPTION	L X H
TAG	Metal 4-Year Inspection Tag	2 1/4" x 3"

This **PLASTIC 4-YEAR INSPECTION TAG** is made of strong 23 mil high-density yellow plastic. It will not break, tear, crack, or become brittle with age and is unaffected by moisture, oils, and grease.

P/N	DESCRIPTION	L X H
4PTAG	Plastic 4-Year Inspection Tag	2 1/4" x 3"



MTAG

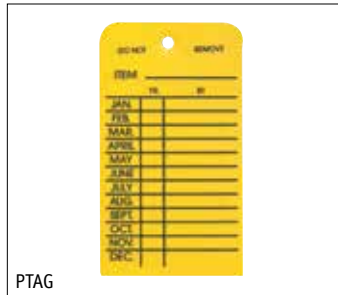

PTAG

Peel-and-stick monthly **INSPECTION TAGS** are printed with green ink on white label stock. Roll/100.

P/N	DESCRIPTION	L X H
MTAG	Inspection Tags	2" x 3"

Designed for outside use, this **PLASTIC INSPECTION TAG** will not tear, break, crack, or become brittle with age. It is unaffected by moisture, oils, and grease and comes with a 12-month record on yellow plastic.

P/N	DESCRIPTION	L X H
PTAG	Plastic Inspection Tag	2 1/2" x 4 1/8"



RT100



FHTAG

The **MONTHLY INSPECTION TAGS**, printed on card stock, is ideal for indoor monthly fire equipment inspections by plant personnel. Pkg/100.

P/N	DESCRIPTION	L X H
RT100	Monthly Inspection Tags	2 5/8" x 5 1/4"

FIRE HOSE INSPECTION/HYDROTEST TAG. Printed with red ink on white card stock.

P/N	DESCRIPTION	L X H
FHTAG	Fire Hose Inspection/Hydrotest Tag	2 7/8" x 5 3/4"



STC In Use



TBZL3 In Use



RFTC2 In Use

TAG ACCESSORIES

TAG COVERS keep dust and moisture away.

NOTE: See Page 329 for Zip Lock Report Holders.

P/N	DESCRIPTION	H X W
STC	Standard Tag Cover 2.5 mil Poly	6 1/2" x 3 1/2"
HSTC	Heavy-Duty Tag Cover 10 mil Frosty Matte Soft Vinyl	6 1/2" x 3 1/8"
TBZL2*	Resealable Tag Cover (Adhesive-Backed) 10 mil Satin	6 3/4" x 3 3/8"
TBZL3*	Resealable Tag Cover 10 mil Satin	6 3/4" x 3 3/8"
RFTC2*	Heavy-Duty Red Flap Tag Cover 10 mil Satin	7 1/6" x 3 3/16"

*MUST ORDER IN LOTS OF 50

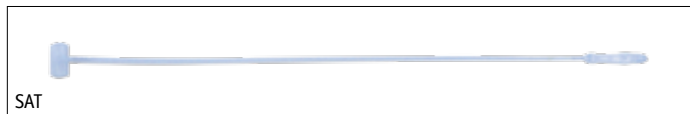

SAT



NS18

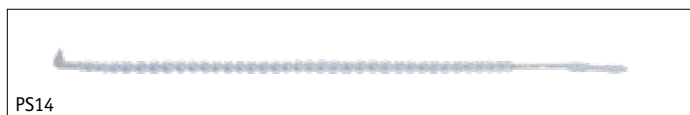

PS14



WF

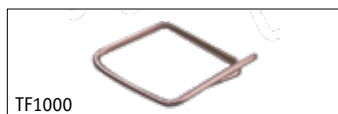

TF1000

TAG FASTENERS

P/N	DESCRIPTION
SAT	5" Secur-A-Tach Tag Seals, Pkg/1000
NS18	5 1/2" Nylon Tag Seals, Pkg/5000
PS14	5 1/4" Polypropylene Seals, Pkg/5000
WF	Galvanized Tag Wires, Pkg/1000
TF1000	Diamond Tag Fasteners, Pkg/1000



10

SERVICE EQUIPMENT



HP2



HP1



HPH



HP3



TP5R



KC1



50ABCULC



50BCPAIL



AX506B2



AX5302

HOLE PUNCHES AND CHAIN REEL

HOLE PUNCHES make a 1/8" round hole and come with clipping receptacles. The **HP1** is light-duty, punching a single paper tag or label. The **HP2** is medium-duty, for more frequent punching of single paper tags and labels. **Ergodyne's HOLE PUNCH HOLSTER (HPH)** features ballistic nylon construction, a stainless steel clip, and two pen/pencil pockets, and it fits most hole punches and utility knives. **NOTE:** For punching multiple paper, metal, and plastic tags as well as molded service collars, etc., please use our **HP3** or **TP5R** punches.

P/N	DESCRIPTION
HP1	Light-Duty Punch w/ 1" Reach
HP2	Medium-Duty Punch w/ 2" Reach
HPH	Hole Punch Holster, 9"L x 2"W x 1"D

HEAVY-DUTY/INDUSTRIAL HOLE PUNCHES can punch more than one tag at a time. The **HP3** has a 2" reach and a clipping receptacle, while the **TP5R** has a 1" reach. Both punch 1/8" round holes and are ideal for punching **Verification of Service Collars**.

P/N	DESCRIPTION
HP3	Industrial Punch
TP5R	Heavy-Duty Punch

The **CHAIN REEL** is a great way to keep track of hole punches, keys, system service pins, and more.

P/N	DESCRIPTION
KC1	Chain Reel

RECHARGE CHEMICAL

UL CLASSIFIED UNIVERSAL DRY CHEMICAL comes in 50 lb pails for use in many manufacturers' fire extinguishers (per NFPA 10).

P/N	DESCRIPTION
50ABCULC	UL ABC Dry Chemical

UNIVERSAL RECHARGE DRY CHEMICAL in 50 lb pails.

P/N	DESCRIPTION
50BCPAIL	BC Dry Chemical
50PKPAIL	PK Dry Chemical
50DPAIL	Class D Dry Powder (Sodium Chloride)
→	OEM DRY CHEMICAL Available on page 24.

OEM LIQUID CHEMICAL CHARGES

P/N	DESCRIPTION
AX502AR	Amerex AR-AFFF Recharge, 23 oz For 6 L & 2.5 gal Extinguishers, Models 250, 252, 254, 250CG
AX506B2	Amerex Antifreeze Charge, Pkg/2 For 2.5 gal Loaded Stream Extinguishers
AX5302	Amerex Recharge, 6 L, Pkg/2 For AX260
AX660	Amerex Recharge, 2.5 gal, Pkg/2 For AX262
AC100	Badger Recharge, 6 L, Pkg/2 For WC100
AC250	Badger Recharge, 2.5 gal For WC250
A430182	Ansul PRX Liquid Agent, 6 L For K-Guard & Piranha, (K01, K01-1)
A423320	Ansul PRX Liquid Agent, 5 gal For K-Guard & Piranha, (K01, K01-1)
BK600872	Buckeye Recharge, 6 L

FireTech's EZ-FILL SIPHON is not only easy but fast—transferring up to 3.5 gal of liquid per minute. The 6' clear hose is durable, flexible, non-toxic, and has a copper nipple that is anti-static and anti-spark for safety. Use it to transfer liquids, including fuels, oils, water, paint, and more. To operate, make sure the liquid to be transferred is higher than the empty container. Submerge the **EZ-Fill Siphon** and shake it to start the transfer.

P/N	DESCRIPTION
EZFILL	EZ-Fill Siphon



EZFILL In Use



EZFILL

FUNNELS, SCOOPS, AND AIR HOSE

The retracting **Brooks AIR HOSE REEL** is long lasting, thanks to the top-quality materials that go into making it. Made of steel, it is covered in a corrosion-resistant powder coating for extra-long life. It comes with 50' of 3/8" rubber hose and includes a multi-position ratchet lock, tension adjustment, and a full-flow swivel that prevents leakage. A guide arm cuts down on hose wear and tear plus, with nine adjustable positions, the reel can be mounted on the ceiling, floor, or wall. 300 psi.

P/N	DESCRIPTION
AHR50	Air Hose Reel w/ 50' Hose



AHR50

COILED AIR HOSES are for blowing out valves, cleaning off work areas, etc. **CH** models are permanently coiled hoses, made from abrasion resistant nylon and fitted with brass fittings. **AHC** models feature flexible polyurethane hose with swivel brass fittings. Hoses come standard with 1/4" NPT(M) fittings on both ends.

NOTE: Do not use for recharge line!

P/N	DESCRIPTION
CH12	Coiled Hose, 12', Yellow
CH25	Coiled Hose, 25', Yellow
AHC12	Coiled Hose, 12', Orange
AHC25	Coiled Hose, 25', Orange



CH25



AD31



SBG1



AHC12



QDC

The **BLOW GUN** setup is ideal for blowing out valves, cleaning work areas, etc.

P/N	DESCRIPTION
SBG1	Safety Blow Gun
AD31	1/4" Quick Disconnect Recharge Adapter
QDC	Quick Disconnect Coupler

FILLING FUNNELS are made of durable galvanized steel with two different heavy-duty mesh screens, properly sized and spaced. The screens eliminate clogging and jamming of the funnel. Available in three sizes.

P/N	DESCRIPTION	H X DIA X OD TIP
FF1	Small Funnel	15" x 6" x 3/4"
FF2	Large Funnel	13" x 10" x 1 1/8"
FF3	Large Neck Funnel	10" x 10" x 2 1/4"



FF1



FF2



FF3

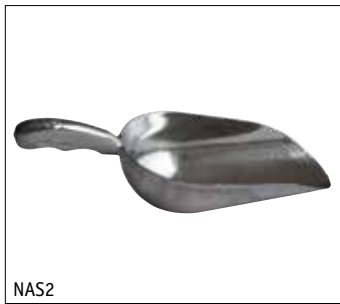

NAS2



PLO

Aluminum **SCOOPS** are perfect for filling dry chemical fire extinguishers.

P/N	DESCRIPTION
NAS1	Scoop, 24 oz
NAS2	Scoop, 38 oz

Aluminum **PAIL OPENER** opens dry chemical pails quickly and easily without harming lids.

P/N	DESCRIPTION
PLO	Pail Opener



VF50

RECHARGE EQUIPMENT

Getz VACU-FILL SYSTEMS are available with 50 and 100 lb-capacity hoppers. They feature single-valve control consoles, filling lines, discharge assemblies, discharge screens, and powder recovery lids and operate on air or nitrogen at 60–80 psi, 1–2 cfm.

P/N	DESCRIPTION	H X W X D
VF50	50 lb Dry Chemical Filling System	25 ¹ / ₄ " x 13" x 17"
VF100D	100 lb Dry Chemical Filling System	31" x 20" x 15"
51221GZ	Fill Cone	
	Fits Vacu-Fill & EZ20 Systems	
51222GZ	Wheeled Unit Fill Cone	
1G0067GZ	Overflow Filter	
	Fits Vacu-Fill & EZ20 Systems	
1G0205GZ	Overflow Jar Gasket	
	Fits Vacu-Fill & EZ20 Systems	
1G0018GZ	Vacuum Gauge, 30" Hg	
51436GZ	Overflow Jar	
	Fits Vacu-Fill & EZ20 Systems	
1G54040GZ	Hopper Lid Filter, 100 & 150 lb	
3G0151GZ	Venturi Tee 50, 100, & 150 lb	
1G54039GZ	Hopper Lid Filter, 50 lb	
58900GZ	Maintenance Kit	
	For VF100D & VF150D	
58901GZ	Maintenance Kit	
	For VF50	
DDP59439GZ	Hopper Bucket Attachment	
	For Filling	



51221GZ



1G0067GZ



3G0151GZ



58900GZ

Getz PLASTIC DRY CHEMICAL FILLING SYSTEMS features high-density polyethylene hoppers and stands that will not rust. Hoppers are translucent, making it easy to see the chemical levels. They are air injected as well, to "fluff" the chemical. Other features include easy-to-operate toggle switches and trouble-free On/Off lids and filters.



3G0050GZ



3G0061GZ

P/N	DESCRIPTION
3G0050GZ	100 lb Dry Chemical Filling System, Yellow
3G0031GZ	150 lb ABC Dry Chemical Filling System, Yellow
3G0116GZ	Single 450 lb ABC Dry Chemical Filling System, Yellow
	For Portables Only
3G0070GZ	Single 450 lb BC Dry Chemical Filling Systems, White
	For Wheeled Units Only
3G0066GZ	Dual 450 lb ABC Dry Chemical Filling System, Yellow
	For Portables Only
3G0061GZ	Dual 450 lb ABC Dry Chemical Filling Systems, Yellow
	For Portables & Wheeled Units
3G0045GZ	Dry Chemical Reclaim Assembly w/ 6 Lids
DCACS	Dry Chemical Adapter & Coupling Set
	For Getz Systems Dry Chemical Filling

These environmentally friendly **CLEAN AGENT RECOVERY SYSTEMS**, from **Getz**, transfer liquid agents and vapor while filtering particulate matter. They indicate moisture content and come with air-driven pumps, heavy-duty frames and consoles, and powder-coated paint finishes. **3G59304GZ** meets and exceeds UL standard 2006, while **3G59304GZ** and **3G59751GZ** operate on compressed air (between 65–80 psi, at a minimum of 13 CFM). **3G59274GZ** also operates on compressed air (100–120 psi, at a minimum of 13CFM).

NOTE: Tanks not included.

P/N	DESCRIPTION
3G59304GZ	Halon 1211 Recovery System
3G59751GZ	Halotron I/FE-36 Recovery System
3G59274GZ	HFC-227 Recovery System
	Compatible w/ FE 25, FE 125, Halon 1301, FM 200, & Novec 1230

The **Getz SERVICE TRUCK DELUXE PACKAGE** includes the **VF50 Vacu-Fill** system, a nitrogen regulator, recharge line with quick coupling, recharge adapter kit, and a pail opener. 50 lb capacity.

P/N	DESCRIPTION
59350GZ	Service Truck Package

Made of aluminum, the **MECHANICAL BENCH VISE** comes standard with an easy-crank handwheel; belted, nonslip vise jaws, and an adjustable rear jaw. Perfect for the shop or job site.

P/N	DESCRIPTION	L X H X W
MBVD	Bench Vise	13" x 7" x 4"

The **Getz PNEUMATIC CYLINDER BENCH VISE** features aluminum construction with nonslip belting. Ideal for mobile or shop use, it operates on 60–80 psi and comes with an easy-to-operate pneumatic toggle switch.

P/N	DESCRIPTION	L X H X W
3G0037GZ	Pneumatic Cylinder Bench Vise	16" x 5" x 4"

The **SuperKan RECOVERY SYSTEM** is a quick, inexpensive way to empty portable dry chemical extinguishers. Constructed from brushed aluminum in an environmentally friendly design, this portable unit comes with a three-tier screen system and holds up to 30 lb of chemical.

P/N	DESCRIPTION
59377GZ	SuperKan
53329GZ	Filter For SuperKan
56251GZ	Rubber Assembly For SuperKan
53354GZ	Foam Seal

The **DCX 20 FILL SYSTEM** adds to or fills extinguishers (via gravity) in seconds. It comes with its own pail that changes out easily, thanks to a fast-connect clamp system. The can itself is constructed from spun aluminum with a white powder-coated finish and features a three-tier screen system that sifts the powder. A 1/2" valve holds the powder back until you are ready to dispense it.

P/N	DESCRIPTION
59341GZ	DCX 20 Extinguisher Filling System
1G0042GZ	Ball Valve, 1/4"
53343GZ	DCX 20 Clamp
53400GZ	20 lb Lid
53401GZ	20 lb Bucket
53433GZ	Rubber Seal Strip, 3 1/2"
59403GZ	Discharge Hose, 3' x 3/8"



3G59304GZ



59350GZ



MBVD

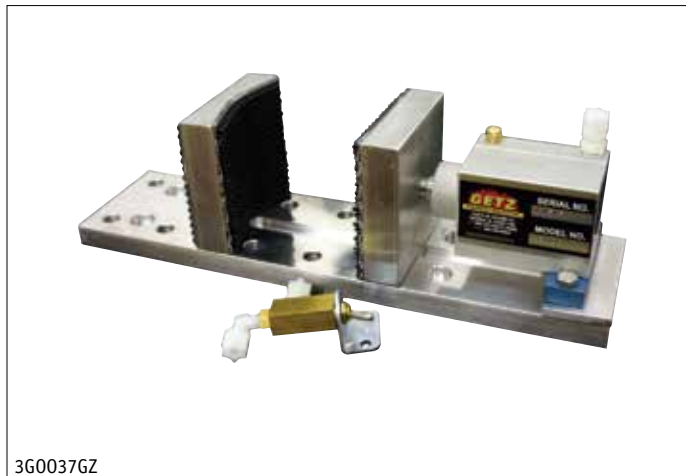

3G0037GZ



59377GZ



59341GZ



BBAG In Use



PPB1 In Use

The easy-to-use **BLOW-OUT BAG** empties dry chemical extinguishers in seconds without a mess, saving time and money. Just place the nozzle or hose into the bag, hold it securely, and release the pressure slowly (until empty). A hook-and-loop closure across the bottom makes it easy to empty.

WARNING: DO NOT mix chemicals! Not recommended for reclaiming chemicals.

P/N	DESCRIPTION
BBAG	Blow-Out Bag



RM16



RP9500

The **POWDER PAIL BAG** controls the flow of powder, keeping dust to a minimum, and fills hoppers.

P/N	DESCRIPTION
PPB1	Powder Pail Bag

This 16 oz **RUBBER Mallet** “fluffs” chemical in cylinders and more.

P/N	DESCRIPTION
RM16	Rubber Mallet



CCAP



GT11

Disposable **DUST MASKS** block non-toxic dusts, powders, and pollen. They are lightweight with adjustable elastic head straps and metal-forming strips over the nose for comfort. Pkg/50.

P/N	DESCRIPTION
RP9500	Dust Masks

CYLINDER VALVE GUARD meets DOT, OSHA, and MSHA requirements. The **GT11** can be fitted and padlocked over a cylinder valve with the regulator attached, while the **CCAP** protects the cylinder valve only. Measures 3 1/8" x 11 tpi.

P/N	DESCRIPTION
GT11	Cylinder Valve Guard
CCAP	Cylinder Cap



SSPRCG1000



2550 In Use

The **RECHARGE GAUGE** features all-stainless, all-welded construction with only 1% fluctuation in accuracy. It includes a 3 1/2" dial and 1/4" NPT lower connection and has a range of 0–1000 psi in increments of 10 psi. Used to meet NFPA 10 requirements when pressurizing extinguishers. Re-calibratable.

P/N	DESCRIPTION
SSPRCG1000	Recharge Gauge
SSPRCG	Re-Calibration Service

The **2550 NITROGEN REGULATOR** setup is for recharging extinguishers. It has a spring-type (re-seating) safety relief, CGA580 inlet connection, 1/4" NPT female outlet, high-strength rubber diaphragm, and a rugged all-metal body. It also comes with part number **NITA** and has a 0–500 psi outlet pressure.

P/N	DESCRIPTION
2550	Nitrogen Regulator w/ NITA (Hose Not Included)
N10H	10' High-Pressure Nitrogen Hose
1000G	1000 psi Replacement Gauge For Nitrogen Regulator
4000G	4000 psi Replacement Gauge For Nitrogen Regulator
NITA	Nitrogen Valve to Regulator Adapter
C02	1/4" F x 1/4" F CO ₂ Coupling



N10H w/ NITA & CO2 In Use

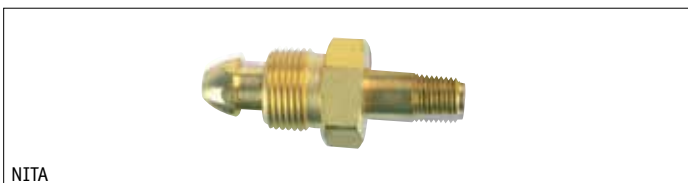

NITA

In Use photos may show items not included or available separately.

This **3-WAY VALVE** provides an easy and safe method of venting pressure when charging dry chemical and other low-pressure fire extinguishers. After reaching the correct extinguisher pressure and installing the extinguisher's pull pin, a half turn of the 3-way valve handle instantly bleeds off the pressure between the **3WV** and the extinguisher (with minimal loss of nitrogen) for safe removal of the quick disconnect (**QDC** or **QDC2**). Use the **4HN** nipple to attach the quick disconnect. Maximum pressure is 500 psi.

P/N	DESCRIPTION
3WV	3-Way 1/4" Valve
4HN	1/4" M x M Hex Nipple For 3-Way Valve



3WV



4HN

SCALES

Ideal for weighing extinguishers during recharge, this **FIXED SPRING DIAL PLATFORM SCALE** features corrosion-resistant construction with a shatter-resistant window. Its dual-read feature displays weight in both English Standard and Metric units. It comes with a zero adjustment knob and has a 13" x 13" platform.

P/N	DESCRIPTION
T100	100 lb x 4 oz Fixed Spring Dial Scale



3WV w/ 4HN IN USE

Built to withstand the demands of a commercial kitchen, this **HEAVY-DUTY HIGH-PERFORMANCE TABLETOP SCALE** is made from stainless steel and features a large angled dial with a shatter-resistant lens. The scale's platform measures 9" x 9", while the entire unit measures 7 1/4"L x 10 5/8"H x 10 7/8"W.

P/N	DESCRIPTION
T40	40 lb x 2 oz Heavy-Duty Tabletop Scale



T100



T40

These **LEGAL-FOR-TRADE SCALES** incorporate a portable wireless design, and feature over/under check weighing, removable stainless steel platforms, and adjustable auto shutoffs. An automatic/semi-automatic zero-setting mechanism and AC adapter (except **BDS160X**) are standard.

NOTE: All units are AC/DC (batteries not included).

P/N	DESCRIPTION
BDS160*	160 oz x 0.1 oz LFT Digital Scale
BDS160X	160 oz x 0.1 oz LFT Digital Scale (Without Adapter)
LTDS60	60 lb x .02 lb LFT Digital Scale
LTDSAC60	AC Adapter For 60 lb Scale & 160 oz Scale
TFDB	D Alkaline Batteries, Pkg/2

*WHILE QUANTITIES LAST!



LTDS60

Getz's LEGAL-FOR-TRADE DIGITAL SCALE has an Auto-Power Off function and includes an optional output to connect peripherals. This AC/DC scale comes with an AC adapter or can operate on four C-cell batteries (not included). Measures 11 13/16" x 16".

P/N	DESCRIPTION
2G0131GZ	150 lb x 0.05 lb LFT Digital Scale
TFDB	C Alkaline Batteries, Pkg/2



2G0131GZ



GHCW110

CLASS 7 WEIGHTS are for scale calibration and satisfy the amendment of CA Title 19, Division 1, Chapter 3 that states scales must be checked with an appropriate Class 7 Weight prior to each use. Test weights are made from cast iron and coated with a layer of chip-resistant paint to keep them from corroding.

P/N	DESCRIPTION
GHCW101	1 lb Class 7 Weight
GHCW110	10 lb Class 7 Weight



101

501

401

PRECISION HANGING SCALES are accurate and dependable with adjustable pointers and heavy-duty steel construction.

P/N	DESCRIPTION
101	110 lb x 1 lb Hanging Scale
501	50 lb x 1 lb Hanging Scale

Designed for weighing cartridges, these **PORTABLE HANGING SCALES** come in two types: the **605**, marked 0–60 oz with 0.5 oz graduations and the **401**, marked 0–4 lb with 1 oz and 0–2 kg with 20 g graduations. The **SCLIP** is for hanging cartridges.

P/N	DESCRIPTION
401	4 lb x 1 oz Portable Hanging Scale
605	60 oz x 0.5 oz Hanging Scale
SCLIP	CO ₂ & Nitrogen Cartridge Scale Clip



605

SCLIP
IN USE

Heavy-duty **UTILITY SCALES** come with low-profile, reinforced ribbed platforms; memory locks; carrying handles; and zero adjustment knobs. Measures 13¹/₄" L x 3⁷/₈" H x 10¹/₂" W.

P/N	DESCRIPTION
US100	100 lb x 1 lb Utility Scale
US250	250 lb x 1 lb Utility Scale



US100

DKS3002

For cartridge filling and inspection, this **ELECTRONIC DIGITAL SCALE** has an LCD digital display, automatic shut off, and includes an AC adapter. Platform measures 5¹⁵/₁₆" x 4³/₄" with a 2000 g x 2 g capacity.

NOTE: Operates on one 9V battery (not included). Call manufacturer for warranty issues.

P/N	DESCRIPTION
DKS3002	4 lb x 0.1 oz Digital Scale
ODS230	AC Adapter For DKS3002
TF9VB	9V Alkaline Battery



PBB135

This **BENCH BEAM SCALE** is legal for trade, conforming to NIST Handbook 44, Class III. It features a bubble level indicator and adjustable leveling legs and reads in ounces or decimal pounds (with 135 lb x 0.1 lb graduations). Includes a 12" x 17" platform.

P/N	DESCRIPTION
PBB135	Beam Scale

SERVICE KITS

Reduce service time with the **UNIVERSAL WHEELED UNIT SERVICE KIT**. Designed for 30–350 lb wheeled fire extinguishers, this kit has all the fittings, adapters, and components to perform annual maintenance on most makes, models, and sizes.

NOTE: Contact our Sales Department for a complete list of kit components.

P/N	DESCRIPTION
WSK30350	Wheeled Unit Service Kit



WSK30350

This **DRY CHEMICAL REFILLING KIT** contains a small funnel (**FF1**), large funnel (**FF2**), regulator (**2550**), large scoop (**NAS2**), complete recharge adapter kit (**RAKIT**), nitrogen hose (**N10H**), and **PTFE** tape (**T520**).

P/N	DESCRIPTION
DCRK	Dry Chemical Refilling Kit



DCRK

START-UP KIT

Brooks' START-UP KIT easily outfits your truck for servicing fire extinguishers. Contents include a dry chemical recharge kit (**DCRK**), valve stem kit (**VSKIT**), O-ring kit (**ORKIT**), rivet kit (**RAKIT**), 100 new-type pull pins (**NPP**), box of comfort masks (**RP9500**), valve cleaning brushes (**VCB**, **NB**, **TB**), scales (**501**, **605**), tube of lubricant (**OLUBE2**), clear parts box (**LPC16**), and a parts bin rack (**PBR1**).

P/N	DESCRIPTION
SUKIT	Start-Up Kit



SUKIT

The **RECHARGE ADAPTER KIT** contains the **ADSET**, (1) **AD31**, (14) **CON1**, (1) **GDC**, and (1) **AC1** in a clear parts bin box (**LPC16**) with a full-scale illustration of each part.

P/N	DESCRIPTION
RAKIT	Recharge Adapter Kit



RAKIT

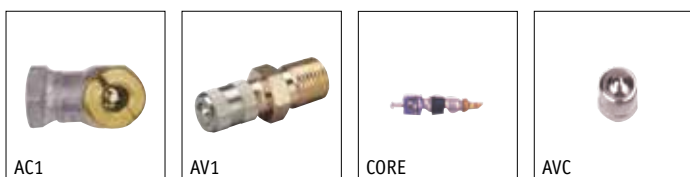

RECHARGE ADAPTERS

Fire extinguisher **RECHARGE ADAPTERS, AIR VALVES, and QUICK DISCONNECT COUPLERS.**

P/N	DESCRIPTION
AD21	Recharge Adapter Fits Amerex, Badger, General, Old Kidde, Pem All, Flag, & RC Ind.
AD22	Recharge Adapter Fits Ansul Sentry 2.5 lb & 5 lb Coarse Thread (Small Valve)
AD23	Recharge Adapter Fits Ansul, Buckeye, Pyronauts, & Kidde (Large Pro Line Units)
AD24	Recharge Adapter Fits Amerex, Ansul, Badger, General, Pem All, Strike, Stop Fire, Buckeye, Flag, Power-Pak, & RC Ind.
AD25	Recharge Adapter Fits Old-Style Kidde Units
AD26	Recharge Adapter Fits RC Ind. Clip-Type Nozzle
AD27*	Recharge Adapter Fits Kidde Nylon Valve w/ Nozzle
AD29	Recharge Adapter Fits Fyr-Fyter, Buffalo, C-0-Two, Pyrene, Norris, & Stop Fire
AD30	Recharge Adapter Fits Ansul Sentry Units Except 2.5 lb (Large Valve)
AD32	Recharge Adapter Fits Kidde Nylon Valve w/ Hose
AD34	Recharge Adapter Fits Kidde Coarse Thread
AD35	Recharge Adapter Fits Kidde Pro Line (Small Units) & New Ansul Sentry
AD36	Recharge Adapter Fits Amerex 270, 272, B260, & B262
AD36W	Washer For AD36
AD38	Recharge Adapter Fits Ansul A025 & A02SVB
ADSET	Recharge Adapter Set AD21-27, 29, 30, 32, 34, 35, 36, & 38

*WHILE QUANTITIES LAST!

Fire extinguisher **RECHARGE ADAPTERS, AIR VALVES, and QUICK DISCONNECT COUPLERS.**

P/N	DESCRIPTION
CRT	Core Removing Tool
AC1	Air Chuck
AV1	Air Valve w/ Cap
CORE	Replacement Core, Pkg/50 For AV1
AVC	Replacement Cap, Pkg/50 For AV1
CON1	Male Quick Disconnect, 1/8" Male NTP Use w/ all AD Recharge Adapters
CON2	Male Quick Disconnect, 1/8" Male NTP Use w/ all AD Recharge Adapters on Getz Recharge System
AD31	Male Quick Disconnect, 1/4" Male NPT Use w/ DCA & AC1
QDC	Female Quick Disconnect, 1/4" Female NPT Use w/ CON1 & AD31
QDC2	Female Quick Disconnect, 1/4" Female NPT Use w/ CON2 on Getz Recharge System
DCA	Discharge Adapter For Cartridge Receiver, Fits Ansul, Badger, & General

CO₂ RECHARGE EQUIPMENT

This single-action **CO₂ TRANSFER PUMP**, from **Getz**, operates on compressed air or nitrogen (130 psi, at 13 CFM) and comes with (4) CO₂ adapters, (1) 3/8" x 10' white poly tubing, (1) 1/2" x 6' supply line hose, and (1) 1/4" x 6' fill line hose.

P/N	DESCRIPTION
4G0010GZ	CO ₂ Transfer Pump

Ansul® and Sentry® are registered marks of Tyco Fire Products LP.

Getz's base-plate-mounted **PNEUMATIC CYLINDER FLOOR VISE** features a formed iron pedestal, with a powder-coated paint finish for excellent corrosion resistance, and nonslip, durable belting to prevent cylinder scratching. Fully adjustable, it accommodates 5 lb–100 lb CO₂ cylinders and opens and closes within seconds. Comes standard with a tool and stamp tray.

P/N	DESCRIPTION
3G58634GZ	Pneumatic Cylinder Floor Vise



CO₂ CHARGING LINE COMPONENTS

P/N	DESCRIPTION
C01	1/2" F x 1/4" F CO ₂ Coupling
C02	1/4" F x 1/4" F CO ₂ Coupling
C07P	Fiber Washers, Pkg/50 For Swivel Nut
C014P	Nylon "Snap In" Washers, Pkg/50
C08	1/8" F x 1/2" M CO ₂ Charging Adapter
C09	1/4" F x 1/2" M CO ₂ Charging Adapter
C010	3/8" F x 1/2" M CO ₂ Charging Adapter
C011	1/2" F x 1/2" M CO ₂ Charging Adapter

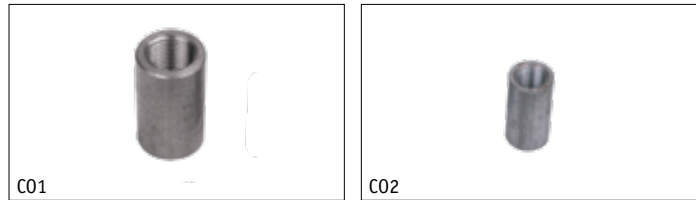

CO₂ CHARGING LINE COMPONENTS

P/N	DESCRIPTION
C012	1/2" F Plastic Hand Nut
C013	2 1/2" Brass Nipple
C015	Flip Valve 1/4" F x 1/4" F For C015
C016	5 lb CO ₂ Charging Adapter
C017	Brass Swivel Nut
C03	6' Charging Hose 1/4" M x 1/4" M
C04	Heavy-Duty Quarter-Turn Ball Valve (2000 WOG-CS)



VALVE HANDLE GRIP for holding squeeze-handle-type valves in the open position.

P/N	DESCRIPTION
VHG	Valve Handle Grip

This **PAINTBALL RECHARGE KIT** features two 1000 psi WOG CO₂ brass ball valves and a CO₂ pin depressor for safe filling and handling.

WARNING: This kit is for refilling paintball cylinders only. A scale must be used to ensure a safe fill. For indoor use only.

P/N	DESCRIPTION
PBRKIT	Paintball Cylinder Recharge Kit

NOTE: The above adapters and components are only a partial list of items and equipment needed to safely refill carbon dioxide cartridges and cylinders. These adapters and components should be purchased and used **only** by personnel who are thoroughly familiar with, and understand, the standards published in the Compressed Gas Association pamphlets G-6 and S-1.1, Code of Federal Regulations Title 49, Parts 100 thru 185, and who have received "hands-on" training under the direct supervision of someone experienced in cartridge refilling. If you lack the knowledge, training, or experience described above, **do not** attempt to refill carbon dioxide cartridges or cylinders. Instead, we recommend that you purchase either new cylinders and cartridges or have them refilled by an established service facility. **Failure to adhere to the above instructions could result in serious injury or death!**

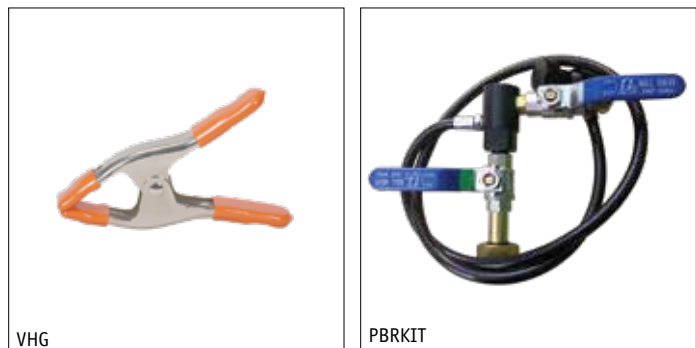
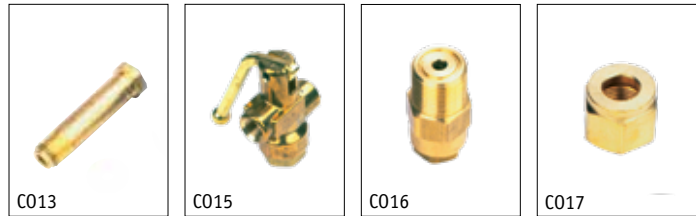
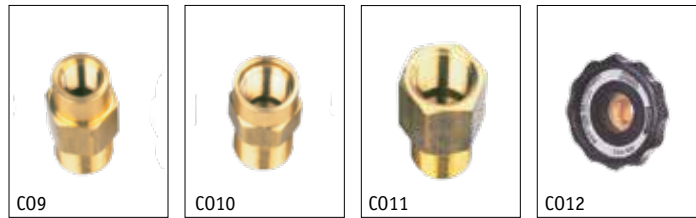

In Use photos may show items not included or available separately.



HTP w/ QDC & N10H In Use



TC In Use

HYDROTEST EQUIPMENT

This **LOW-PRESSURE HYDROTEST PUMP** is made of cast aluminum with stainless steel pistons and a 0–1000 psi pressure gauge. Order hose (**N10H**) and quick disconnect coupler (**QDC**) separately. Weighs 12 lb.

P/N	DESCRIPTION
HTP	Hydrotest Pump (Pump Only)
HPCS	Replacement Check Stem Kit For Hydrostatic Test Pump
N10H	10' High-Pressure Nitrogen Hose
1000G	1000 psi Replacement Gauge For Hydrostatic Test Pump
QDC	Quick Disconnect Coupler
OR27	O-Ring For Piston (2 Required)



3G58630GZ

Brooks' TEST CAGE comes with a durable red powder paint finish, 13 ga steel mesh, and 11 ga steel frame with mounting holes on the bottom. Its top has a 1½" hole for a test hose, while its hinged door has a latch for easy access. Weighs 29 lb. Measures 31"H x 12"W x 11"D.

P/N	DESCRIPTION
TC	Test Cage



3G0078GZ

The **Getz AIR PUMP HYDROSTATIC TEST SYSTEM** is air powered with a 0–800 liquid filled gauge and **Getz Head Assembly**. Other features include a rotating safety cage and an air blowout valve for dispersing water from an extinguisher. A filtration system also filters out dry chemical during the emptying cycle and its fill and empty come with female quick couplings. Garden hose hook up. Operates on 80–100 psi shop air, nitrogen, or CO₂ vapor. **NOTE:** Requires 3G0078GZ to comply with U.S. DOT regulations!

P/N	DESCRIPTION
3G58630GZ	Air Pump Hydrostatic Test System

Getz's TEST CYLINDER WITH MASTER GAUGE calibrates cylinders for low-pressure hydrotesters and comes with a DOT and NFPA compliant gauge.

P/N	DESCRIPTION
3G0078GZ	Test Cylinder w/ Master Gauge



3G0047GZ In Use

The **HYDRO AID COMPLETE**, from **Getz**, removes any remaining dry chemical prior to hydrotesting and any residual water after hydrotesting to decrease drying time. It comes standard with an incoming air supply to a ½" ball valve (100 psi max) and a 1½" vacuum port for a shop vac (not included) with a HEPA filter.

P/N	DESCRIPTION
3G0047GZ	Hydro Aid Complete

This **CYLINDER DRYER** produces 1400 W at 1/3 hp for decreased drying times. It connects to a standard 110 VAC outlet with its 20' cord.

P/N	DESCRIPTION
59705GZ	Getz Cylinder Dryer

This temperature-controlled, 1-hp **COMPACT CYLINDER DRYER** features **Getz's** economy **Hot Blower** mounted inside. Ideal for service trucks and shops. 120 VAC. 95 CFM.

P/N	DESCRIPTION
3G0101GZ	Compact Cylinder Dryer

The **CERTIFIED TEST GAUGE**, for hydrostatic testing of low-pressure cylinders (required by NFPA 10), meets test gauge requirements for both volumetric expansion and modified hydrostatic (proof pressure) testing of DOT-specified cylinders. An additional gauge should be used as a master gauge for a daily system check, as required by NFPA 10. It features a 0–1000 psi range, 0.25% accuracy (full scale), and 5 psi minor graduations and has an externally adjustable dial that measures 4 1/2". The gauge has a 1/4" NPT lower connection that fits the **HTP** test pump, plus it is calibrated and certified prior to shipment. **Brooks** can deadweight test and recertify your test or master gauges in our Charlotte, N.C. location. Send carefully packed gauges (with ALL adapters removed), marked "GAUGE SHOP," to our Charlotte address. Your re-certified gauge will be shipped back within two business days of receipt (using the same method of shipment unless otherwise instructed). Not for high-pressure testing!

WARNING: Not responsible for damage due to adaptors not being removed before shipping! Brooks cannot repair damaged gauges!

P/N	DESCRIPTION
SSPTG1000	1000 psi Certified Test Gauge
SSPDW11	Deadweight Test & Re-Certify Gauge

This **DUAL-GAUGE ASSEMBLY**, from **Getz**, meets the same requirements as our **Certified Test Gauge** and includes two 0-800 psi digital gauges, a dual 45° gauge block with an air-bleed valve, and a drain line. It features a shutoff valve at the working and master gauge assembly, 6' of pressure line, a shutoff valve for connecting to your existing pump, and a mounting bracket.

P/N	DESCRIPTION
DDP59327GZ	Dual-Gauge Assembly

CYLINDER INSPECTION LIGHTS come with protective covers/extensions and flexible shafts that can be bent to most any desired angle. Batteries included.

P/N	DESCRIPTION
24CIL	24" Cylinder Inspection Light, Krypton Lamp
16CIL	16" Cylinder Inspection Light, Incandescent Lamp
110KRP	Krypton Replacement Bulb
100S	Incandescent Replacement Bulb



59705GZ



3G0101GZ In Use



SSPTG1000



DDP59327GZ



16CIL



IM



SIM

These **INSPECTION MIRRORS** include the **IM**, which telescopes from 5³/₄" to 27" and features an adjustable, 7/₈" Dia mirror and magnetic end. The **SIM** is 9¹/₄" long with a fixed 5/₈" Dia mirror.

P/N	DESCRIPTION
IM	Inspection Mirror, Adjustable
SIM	Inspection Mirror, Fixed

HYDROTEST ADAPTERS

Low-pressure **HYDROTEST ADAPTERS** for proof-pressure testing portable extinguishers.



HTA1, HTA10R HTA3, OR333 HTA5, OR30 HTA7, OR21



HTA9, OR29 HTA10, HTA10G HTA11, OR26 HTA12, G48, QR39



HTA13, 615AC HTA14, OR33 HTA15, OR31 HTA16, OR315



HTA17, HTA10G HTA18, OR35 HTA19, OR295 HTA20, OR19



HTA21, OR23 HTA23, SJSJG15 HTA24, OR43 HTA39, OR217



HTA41, HTA410R HTA42, OR29 HTA43, OR28 HTA44, OR29



HTA45, OR27 HTA46, OR27 4892A 5720A

P/N	DESCRIPTION
HTA1*	Fits General Extinguishers
HTA3	Fits Badger & American LaFrance Extinguishers
HTA5	Fits General & Kidde Extinguishers
HTA7	Fits Buckeye, General, Pem All, PowerPak, Pyronauts, & RC Ind. Extinguishers
HTA9	Fits Amerex, Ansul, Badger, & American LaFrance Extinguishers
HTA10	Fits Amerex, Badger, General, & Kidde Water Pressure Extinguishers
HTA11	Fits Amerex & Ansul Extinguishers
HTA12	Fits Ansul & General Extinguishers
HTA13	Fits Ansul Extinguishers
HTA14	Fits Kidde Extinguishers
HTA15	Fits General Extinguishers
HTA16	Fits Kidde Extinguishers
HTA17	Fits Kidde Extinguishers
HTA18	Fits Kidde Extinguishers
HTA19	Fits American LaFrance & Stop Fire Extinguishers
HTA20	Fits General Extinguishers
HTA21	Fits Pem All Extinguishers
HTA39	Fits Kidde Extinguishers
HTA43	Fits Ansul Dry Chem & Cleanguard Extinguishers
HTA44	Fits Badger Extinguishers
HTA45	Fits Badger & American LaFrance Extinguishers (10-20 lb Large Valve)
HTA46	Fits Ansul Water & Wet Chem Extinguishers
4892A	Fits Amerex DC Wheeled Units Cylinder Hose Opening
5720A	Fits CEH75 Chemical Engine Hose

*WHILE QUANTITIES LAST!

Low-pressure **HYDROTEST ADAPTERS** for proof-pressure and water jacket testing system cylinders.

P/N	DESCRIPTION
HTA23	Fits Old-Style Range Guard Systems & Fyr-Fyter Systems
HTA24	Fits Kidde Systems, Pyro-Chem Systems, & Badger Range Guard Systems
HTA41	Fits Pyro-Chem Wet Systems
HTA42	Fits Ansul UL300 Systems

Low-pressure **HYDROTEST ADAPTER SET** is compatible with **Ansul®** and **General** cartridge-operated units.

P/N	DESCRIPTION
AGTSET	Hydrotest Adapter Set (Includes HTA12)



AGTSET

Low-pressure **HYDROTEST ADAPTER** accessories.

P/N	DESCRIPTION
14BV	Miniature Ball Valve, 1/4" M x F NPT
AD31	Quick Disconnect Adapter, 1/4" Male NPT For all HTA's except HTA24
QDC	Quick Disconnect Coupler, 1/4" Female NPT
1G0249GZ	Adapter For HTA Adapter (Use w/ Getz Hydrotest Equipment)
HTA10R	Replacement O-Ring For HTA1
HTA20R	Replacement O-Ring For HTA2
HTA10G	Replacement Gasket For HTA10
HTA410R	Replacement O-Ring For HTA41

High-pressure **HYDROTEST ADAPTERS** for use in water jacket high-pressure test units.

P/N	DESCRIPTION
HPTA27	1 1/8" UNE, Aluminum Cylinders & Extg
HPTA28	3/4" UNE, Scott Air Cylinders-II & Aluminum ICC 2015, Sportsway Dive Tanks & Others
HPTA32*	1/2" NGT, Commercial Gas Cylinders & CO2 Extg
HPTA33	3/4" NGT, Commercial Gas Cylinders & CO2 Extg
HPTA34	1" NGT, Commercial Gas Cylinders & CO2 Extg
HPTA35	3/4" Straight Pipe, Dive, Scuba, & Aqua Tanks
HPTA36	1/2" Straight Pipe, MSA & Others
HPTA37	1 1/4" UNE, Aluminum Cylinders & Extg
HPTA38	3/4" UNE, MSA, FRP, & Others w/o O-Ring Groove

*WHILE QUANTITIES LAST!

High-pressure **CARTRIDGE HYDROTEST ADAPTERS** to be used in water jacket high-pressure test units.

P/N	DESCRIPTION
CTA1	Left-Hand Thread High-Pressure Test Adapter Fits Ansul & General Cartridges
CTA2	Right-Hand Thread High-Pressure Test Adapter Fits Ansul & General Cartridges

STAMP HOLDER AND STAMPS

Custom **DOT IDENTIFICATION STAMPS** come with your Department of Transportation identification number in your choice of sharp or low stress. Delivery is two to three weeks.

NOTE: Signed proof required for production of custom DOT stamps.

P/N	DESCRIPTION
SSPD0TL	Custom Low-Stress DOT Stamp, 3 3/4" L x 3/4" w/ 1/8" Characters
SSPD0TS	Custom Sharp DOT Stamp, 3 7/8" L x 3/4" w/ 1/8" Characters

DOT METAL STAMPS with 1/4" characters.

P/N	DESCRIPTION
MS3AL	"3AL" Low-Stress Metal Stamp
MSP	Plus (+) Symbol Stamp
MSST	Star Symbol Stamp
MSSD	Sharp Face Metal Stamp, "18"
MSLD	Low-Stress Metal Stamp, "18"



In Use photos may show items not included or available separately.

Ansul® is a registered mark of Tyco Fire Products LP.



MS

STEEL STAMPS are manufactured to meet the most demanding industrial applications with an extra-heavy, extra-long shank and supporting level. They feature character identification, size, and three thumb grooves and cut 1/4" numbers.

P/N	DESCRIPTION
MS	Steel Stamp Set (0–9 Stamps)
MS0	Number 0 Steel Stamp
MS1	Number 1 Steel Stamp
MS2	Number 2 Steel Stamp
MS3	Number 3 Steel Stamp
MS4	Number 4 Steel Stamp
MS5	Number 5 Steel Stamp
MS6	Numbers 6 & 9 Steel Stamp
MS7	Number 7 Steel Stamp
MS8	Number 8 Steel Stamp
MSLS	Low-Stress Stamp Set (0–9 Stamps)



SH2

Ideal for hitting stamps and making readable marks, this **2 LB STAMPING HAMMER** has an 8" shaft for easy control. Yellow.

P/N	DESCRIPTION
SH2	Stamping Hammer



HSH In Use

MISCELLANEOUS

Hands-Off Chisel Grip TOOL HOLDER securely holds steel stamps and other tools. It absorbs vibration and protects fingers.

P/N	DESCRIPTION
HSH	Tool Holder



VCB

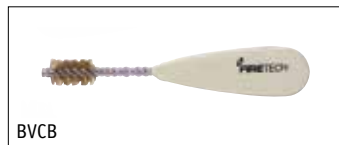

BVCB

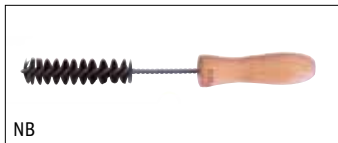

NB



TB



NWB

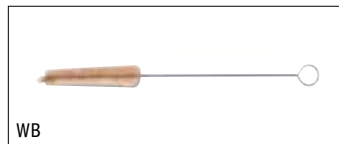

WB



CWB



PDB

BRUSHES are ideal for cleaning valves, threads, etc.

P/N	DESCRIPTION
VCB	Metal Bristle Cleaning Brush
BVCB	Brass Bristle Cleaning Brush For Aluminum
NB	Nylon Bristle Cleaning Brush
TB	Cleaning Brush
NWB	Nylon Cleaning Brush
BWB	Brass Cleaning Brush
WB	Nylon Wire Brush
CWB	Industrial-Grade Wire Brush
PDB	6" Pipe Dope Brush

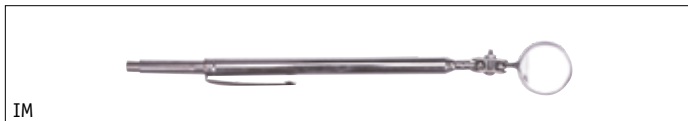

IM

These **INSPECTION MIRRORS** include the **IM**, which telescopes from 5 3/4" to 27" and features an adjustable 7/8" Dia mirror and magnetic end. The **SIM** is 9 1/4" long with a fixed, 5/8" Dia mirror.

P/N	DESCRIPTION
IM	Inspection Mirror, Adjustable
SIM	Inspection Mirror, Fixed



SIM

The **O-RING REMOVAL KIT** consists of a handle and four different tools in a handy vinyl storage pouch.

P/N	DESCRIPTION
ORRK	O-Ring Removal Kit

Craftsman's carbon steel **4-PIECE PICK SET** is ideal for removing O-rings, gaskets, seals, and more. Picks come with cushioned-grip handles.

P/N	DESCRIPTION
4PPS	Pick Set

GAUGE SERVICE EQUIPMENT

Designed for pressurized water extinguishers, this **GAUGE TESTER** features a rugged bronze bourdon tube and brass movement. It holds pressure until released and doubles as a tire gauge. Comes complete with operating instructions.

P/N	DESCRIPTION
PWGT	Gauge Tester

BUBBLES LEAK DETECTOR adheres to overhead surfaces, leaves no residue, and dries clean and clear. Its patented self-storing "Squirtubes" have small bores for dispensing small quantities, and it is okay to use for CO₂, nitrogen, and halon. 8 oz.

P/N	DESCRIPTION
LD1	Leak Detector

The **GAUGE WRENCH** is designed for removing/attaching most gauges and features 3/16" cold-rolled plated steel construction.

P/N	DESCRIPTION
GWRENCH	Gauge Wrench

PENS AND MARKERS

With their pressurized ink technology, **Uni-Ball® POWER TANK™ BALL POINT PENS** meet the challenges of adverse writing conditions—wet surfaces, at any angle. Smooth writing, they even work in extreme cold or upside down. Retractable. 1.0 mm.

P/N	DESCRIPTION
PTPBK	Power Tank Pen, Black
PTPBL	Power Tank Pen, Blue

Sharpie® PERMANENT MARKING PENS write on metal, plastic, vinyl, and more and resist smudging.

P/N	DESCRIPTION
PMC	King Size Permanent w/ Marker, Black
PMP	Fine Permanent Marking Pen, Black
PMUR	Ultra-Fine Permanent Marking Pen, Black
→ IPMP	Industrial Permanent Marking Pen, Fine, Black

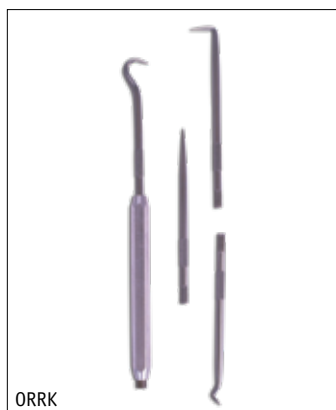

ORRK

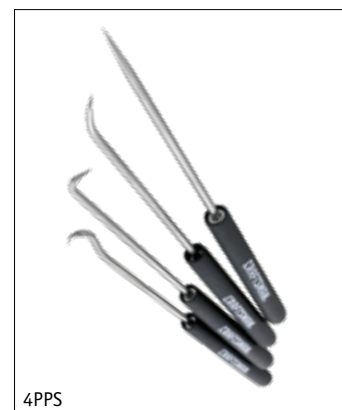

4PPS



PWGT



LD1



GWRENCH



PTPBK, PTPBL



PMC

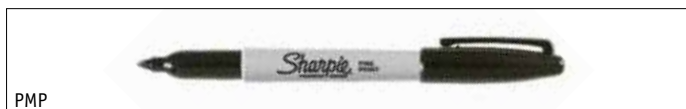

PMP



PMUR



→ NEW
IPMP



PTMPY

Sharpie® medium-point **PAINT MARKERS** are permanent, oil-based, valve-action paint pens that mark on virtually any surface—metal, pottery, wood, rubber, glass, plastic, stone, and more. Quick drying, they are fade, water, and abrasion resistant for a long-lasting mark. Non-toxic and xylene-free.



PMFRTBK

P/N	DESCRIPTION
PTMPBK	Paint Marking Pen, Black
PTMPR	Paint Marking Pen, Red
PTMPY	Paint Marking Pen, Yellow



CAT



CA1

Sharpie's fine point **RETRACTABLE PERMANENT MARKERS** have no cap to lose for easier one-handed operation. **Safety Seal™** valves prevent them from drying out, while their fast-drying, non-toxic ink writes on almost any surface.

P/N	DESCRIPTION
PMFRTBK	Retractable Permanent Marker, Black
PMFRTR	Retractable Permanent Marker, Red

FASTENERS

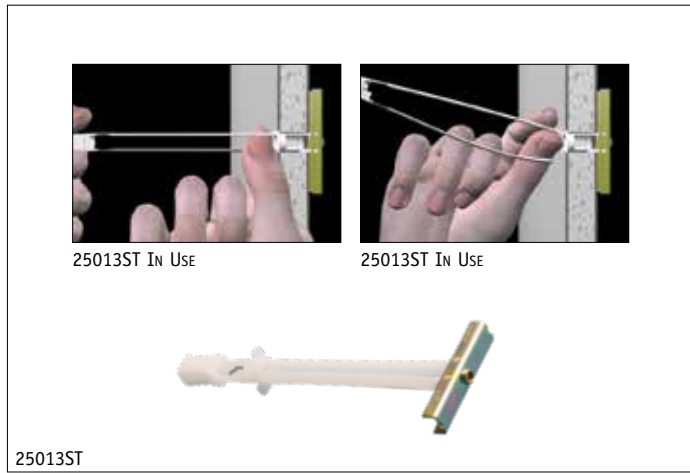

25013ST IN USE

25013ST IN USE

25013ST

Tapcon® **SELF-TAPPING CONCRETE ANCHORS** are the fastest way to secure wall brackets and cabinets to concrete. Just drill pilot holes and screw them in. There are no plastic or metal plugs needed, as they cut their own threads into masonry and hold strong in block, brick, or poured concrete. The **CondriVe® 1000 INSTALLATION TOOL** offers easy installation.

P/N	DESCRIPTION
CA1	Tapcon Anchors, Pkg/100
CAT	CondriVe 1000 Installation Tool, 1/4" x 1 3/4"

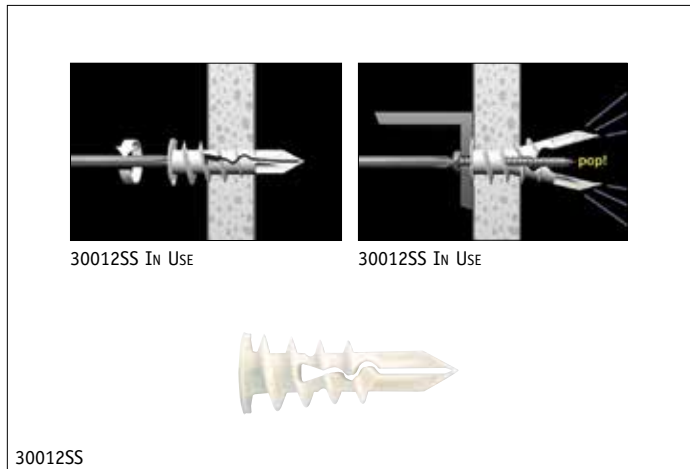

30012SS IN USE

30012SS IN USE

30012SS

SnapToggle® heavy-duty hollow wall **ANCHORS** are for use in walls, ceilings, and floors made of gypsum board, drywall (with steel studs), concrete block, tiled drywall, and more. Their solid-metal channels secure their bolts, out holding wing toggles. Self-drilling **SnapSkru®** **ANCHORS** are the only version that lock symmetrically on the wall and ceiling for truly secure fastening. When activated with screws, **SnapSkru** anchors open with audible “pops” locking them on walls with much greater force than other self-drilling anchors. Pkg/50.

P/N	DESCRIPTION
25013ST	3/16" SnapToggle Anchors w/o Bolts
50TOG	3/16" x 1 1/2" Phillips Head Bolts For 25013ST
30012SS	SnapSkru Anchors w/ Screws

E-Z Ancor™ SELF-DRILLING DRYWALL ANCHORS

require no pre-drilling and install easily using a **Phillips®** screwdriver or power-driver. They offer deep thread engagement for added strength in 3/8" to 5/8" wallboard (sheetrock), and they do not leave big, gaping holes when removed. Screws are #8 x 1 1/4". Items sold separately. Pkg/100.

P/N	DESCRIPTION
EZP	E-Z Ancor Anchors, Plastic
EZM	E-Z Ancor Anchors, Metal
EZS100	E-Z Ancor Screws

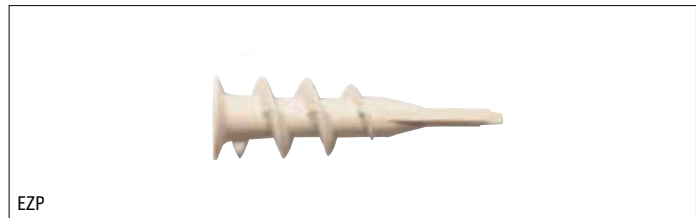

EZP



EZM

E-Z Toggle® SELF-DRILLING TOGGLE ANCHORS require no pre-drilling and install easily using a **Phillips®** screwdriver or power driver. Their unique, patented clamps replace both 1/8" and 3/8" winged toggles. They offer deep thread engagement for added strength in 3/8" to 5/8" wallboard (sheetrock) and will not leave big gaping holes when removed. Screws included. Pkg/50.

P/N	DESCRIPTION
EZTOG	E-Z Toggle Anchors



EZTOG

SELF-DRILLING STEEL FASTENERS easily tap into 1/4" to 1/2" steel—and without drilling. These hex head #12 x 1 1/4" long-milled self-drillers feature non-walking points with precise cutting edges, and their unique design increases drilling performance, requiring less end pressure. Pkg/100.

P/N	DESCRIPTION
SA1	Self-Drilling Fasteners



SA1

TOGGLE BOLTS and WASHERS. Pkg/100.

P/N	DESCRIPTION
RHTB	3" x 3/16" Round Head Toggle Bolts
FW1	1" x 3/16" Fender Washers
FW15	1 1/2" x 1/4" Fender Washers



RHTB

PTFE TAPE

P/N	DESCRIPTION
T520	1/2" x 520" PTFE, White
T75	3/4" x 520" PTFE, White
T520HD	1/2" x 520" PTFE, Hi-Density, Pink



T520HD, T75

Penetrates & Protects



BA2

Brooks BECO LUBE was made with the fire safety industry in mind. It lubricates, cleans, penetrates, and protects parts. 11 oz aerosol.

P/N	DESCRIPTION
BA2	BECO Lube



BA1

AEROSOLS

Brooks' Sign On! SPRAY ON ADHESIVE bonds signs to almost anything. 9.5 oz aerosol.

P/N	DESCRIPTION
BA1	Spray On Adhesive



BA4

Brooks' Krazy Kleen multi-purpose **INDUSTRIAL STRENGTH CLEANER**. 19 oz aerosol.

P/N	DESCRIPTION
BA4	Industrial Strength Cleaner



LOAR

Lift Off® ADHESIVE REMOVER effectively removes adhesives, chewing gum, grease, tar, and motor oil. 10.5 oz aerosol.

P/N	DESCRIPTION
LOAR	Adhesive Remover



800001QC

De-Ice FROST & ICE REMOVER works on windshields, steps, door locks, sidewalks, and more. When used as a pre-treatment, it helps prevent ice and frost on windshields and windows. Its no-residue formula is safe for paint, glass, rubber, metal, plastic, and cloth. 12 oz aerosol. Case/12.

P/N	DESCRIPTION
800001QC	Frost & Ice Remover



FTS2

FireTech™ SMOKE DETECTOR TESTER is for functional testing of photoelectric and ionization smoke detectors. Non-toxic. 2.6 oz aerosol. UL listed.

P/N	DESCRIPTION
FTS2	FireTech Smoke



AB2000

Clean Jet 100 AIR DUSTER is an ultra-filtered dust remover that produces strong blasts of air (up to 100 psi) with zero ozone depletion potential. It leaves no residue, and its extender tube offers pinpoint accuracy in tight spaces. Non-flammable. 10 oz aerosol.

P/N	DESCRIPTION
AB2000	Air Duster

HAND CARE PRODUCTS

WypAll® WIPERS provide better absorption than shop rags and come in different thicknesses for different jobs. Using **Hydroknit®** technology, they combine excellent absorbing power in a lightweight wiper that takes up less space than rags. The **JUMBO ROLL DISPENSER** makes dispensing wipers easy.

P/N	DESCRIPTION
KCW180	Brag Box Wipers, 12 ¹ / ₂ " x 16 ³ / ₄ ", White, 180 ea Replaces 25 lb of Scrap Rags
KCHDW475	Jumbo Roll Wipers, 12 ¹ / ₂ " x 13 ³ / ₈ ", Red, 475 ea Replaces 75 lb of Scrap Rags
KCHDD	Jumbo Roll Dispenser, 16 ³ / ₄ "L x 33"H x 18 ¹ / ₂ "W
KCHWM	Jumbo Roll Wall Mount Dispenser, 16 ³ / ₄ "L x 8 ³ / ₄ "H x 10 ³ / ₄ "W



KCW180



KCHDD w/ KCHDW475 In Use

Pumice-powered **Lava®** heavy-duty **HAND CLEANERS** cut through the heaviest grease and grime. They contain moisturizers, so they get extremely dirty hands really clean without drying them out. **Lava** removes dirt, grease, oil, ink, tar, paint, caulk, adhesives, and more. 5.75 oz.

P/N	DESCRIPTION
LAVA	Bar Soap
LAVA2	Bar Soap, Pkg/2



LAVA

GoJo® HAND CLEANERS are specially formulated to gently remove a variety of light greases and oils, effectively cleansing hands quickly.

P/N	DESCRIPTION
GJS095806	Orange Pumice Hand Cleaner w/ Pump Dispenser, 1/2 gal
GJW629804	Fast Towels Multi-Purpose, Container/130 ea



GJS095806



GJW629804

Scott® RAGS IN A BOX are specifically designed for hands-on work. These soft, absorbent towels perform with the strength, durability, and absorbency of a cloth and come in a convenient **Pop-Up Box** with a built-in handle for easy transport. 10" x 13". White.

P/N	DESCRIPTION
KCRB200	Rags In A Box, Box/200

Scott® SHOP TOWELS are strong, soft, and absorbent and work like cloths. They are great for wiping hands and cleaning tools and easily absorb liquids, oil, and grease. They fit on standard towel holders for convenient dispensing. 10³/₈" x 11". Blue.

P/N	DESCRIPTION
KCST55	Shop Towels, Roll/55



KCRB200



KCST55



PDTAPE

TAPE

This advanced-strength **Duck® Brand DUCT TAPE** is the choice of professionals and homeowners alike. 9 mil. 1⁷/₈" x 60 yd. Silver.

P/N	DESCRIPTION
PDTAPE	Duct Tape

Made for all types of electrical jobs, except those exceeding 600 volts, **Duck® Brand ECONOMY** and **Pro Series ALL-PURPOSE ELECTRICAL TAPES** are 7 mil thick, 3/4" wide, UL listed, and CSA certified. **All-Purpose** version is flame retardant and weather resistant. Black.



EETAPE



PETAPE

P/N	DESCRIPTION
EETAPE	Economy Electrical Tape, 60'
PETAPE	All-Purpose Electrical Tape, 66'

Duck® Brand HD Clear™ HIGH-PERFORMANCE PACKAGING TAPE is heavy-duty bulk tape that is ideal for sealing boxes and other jobs. Meets postal regulations. 2.6 mil. 1⁷/₈" x 54.6 yd. Clear. Pkg/6.

P/N	DESCRIPTION
HPTAPE6	Packing Tape



HPTAPE6



TAPEGUN

The **Duck® Brand STANDARD TAPE GUN** features an adjustable tension control knob and has a comfortable handle. Holds up to 2"-wide tape.

P/N	DESCRIPTION
TAPEGUN	Standard Tape Gun



CCW1

TOOLS

This **CAP WRENCH** works on most cartridge-operated fire extinguishers.

P/N	DESCRIPTION
CCW1	Cap Wrench



AW1 In Use

Constructed of solid steel for a lifetime of service, this **SLIP JOINT VALVE WRENCH** fits all manufacturers' CO₂ valves.

P/N	DESCRIPTION
AW1	Slip Joint Valve Wrench

Craftsman® HEAVY-DUTY IRON PIPE WRENCHES

feature tough cast-iron housings and I-beam handles. They come with full-floating hookjaws that use self-cleaning threads.

P/N	DESCRIPTION
10CPW	10" Pipe Wrench 1½" Capacity
14CPW	14" Pipe Wrench 2" Capacity

Reversible ratchet **TORQUE WRENCHES** feature dial-in torque settings, permitting precise tightening to specifications. Their click stops (with 4% accuracy) indicate desired torque by feel and sound, while their heavy-duty cam and pawl actions make quick work of tough jobs.

P/N	DESCRIPTION
TW	18" Torque Wrench w/ ½" Drive, 10–150 ft-lb
TW2	10" Torque Wrench w/ ⅜" Drive, 40–200 in-lb

The **170-PIECE MECHANIC'S TOOL SET**, from **Crescent**, contains a carefully selected assortment of hand tools for a wide variety of applications. Set includes ¼", ⅜", and ½" quick-release ratcheting drives with numerous standard and deep sockets in the most common SAE and metric sizes. Its sturdy carrying case makes tools easy to find and set to go anywhere. All tools meet stringent ANSI and ASME specifications.

P/N	DESCRIPTION
170PCTK	170-Piece Mechanic's Tool Set

Crescent's ADJUSTABLE WRENCHES feature chrome-plated finishes and are constructed from heat-treated alloy steel and come with easy thumb adjustments.

P/N	DESCRIPTION
TL0806	6" Adjustable Wrench
TL0810	10" Adjustable Wrench

Crescent's Rapidslide™ ADJUSTABLE WRENCH features a "slide control" in the handle for fast, accurate jaw adjustment and an internal debris shield to protect the slide mechanism and keep it moving freely. Other features include a 1¼" (maximum) jaw opening capacity and a wide handle for increased leverage.

P/N	DESCRIPTION
TLAC8	8" RapidSlide Wrench

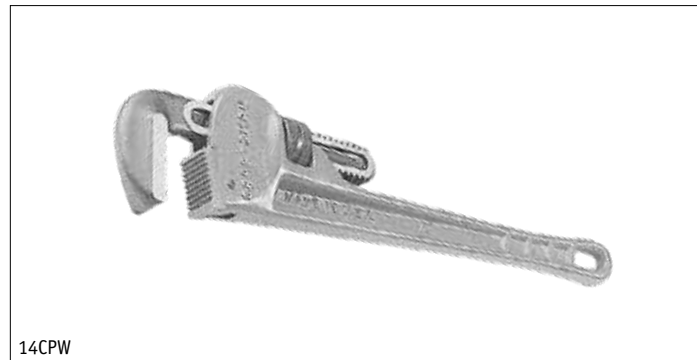

14CPW



TW



170PCTK



TL0810



TLAC8



Crescent's RapidRench ADJUSTABLE SOCKET WRENCH has a 1/4"-7/8" adjustable jaw for 38 different nut and bolt sizes. Its jaw design extends into deep areas, while its comfort grip reduces hand and wrist stress.

P/N	DESCRIPTION
TLFR28	8 1/2" RapidRench Wrench

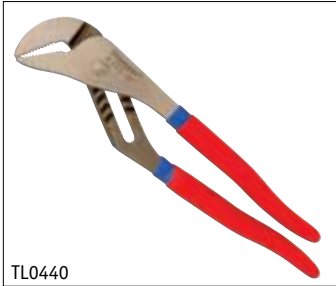

Crescent's TONGUE & GROOVE PLIERS feature unique teeth for increased grip and torque, precision milled ribs for a positive interlock, alloy steel construction for years of trouble-free use, and cushion grip handles.

P/N	DESCRIPTION
TL0440	12" Tongue & Groove Pliers
TL0420	10" Tongue & Groove Pliers
TL0426	7" Straight Jaw Tongue & Groove Pliers



The **WIRING TOOL** features specially heat-treated blades for long life and **Channellock-Blue®** comfort grips for easier use.

P/N	DESCRIPTION
TL908	8 1/4" Wiring Tool



Make changing links fast and easy with these **LINKAGE PLIERS** from **Brooks**. No more scrunching fingers and busting knuckles trying to release cable pressure on scissor brackets. Simply place the specially curved steel jaws in the bracket holes and squeeze for fast, effortless link replacement.

P/N	DESCRIPTION
TL915	Linkage Pliers, Locking
TL910	Linkage Pliers, Non-Locking

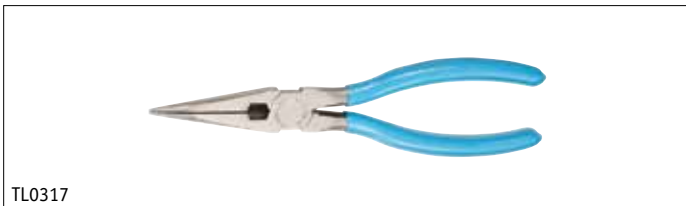

These **LONG-NOSE PLIERS**, from **Channellock**, are made from high-carbon steel with knife- and anvil-style cutting edges for perfect mating and longevity. **Channellock-Blue®** comfort grip handles are standard.

P/N	DESCRIPTION
TL0317	8" Long-Nose Pliers



Crescent® PLIERS feature shear-style wire cutters, heat treated to hold their edge. Made of forged alloy steel, all pliers come with nonslip cushion-grip handles for extra control and comfort.

P/N	DESCRIPTION
TL0526	6 1/2" Slip Joint Pliers
TL060	7" Long Needle-Nose Pliers

Vise-Grip® LOCKING PLIERS can be used for turning, cutting, tightening, clamping, and twisting. They feature a hardened tooth design to grip from any angle and an adjusting screw for exact pressure during repetitive use. Constructed of alloy steel and heat treated for extra toughness and durability. Additionally, **TLVG1** and **TLVG3** feature a built-in wire cutter that cuts bolts (up to a 1/4").

P/N	DESCRIPTION
TLVG1	7" Curved-Jaw Vise-Grips w/ Wire Cutter
TLVG2	7" Straight-Jaw Vise-Grips
TLVG3	6" Long-Nose Vise-Grips w/ Wire Cutter

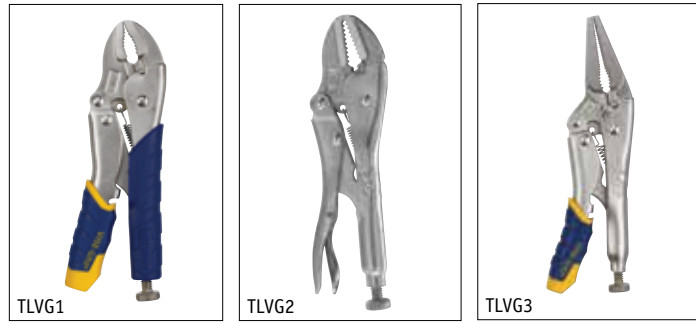

Shear-cut **SNAPPER WIRE CUTTERS** have micro-sized, premium-quality steel jaws that hold their edge, while cushioned grips offer comfortable use and less hand fatigue.

P/N	DESCRIPTION
TL20033	5 3/4" Snapper Wire Cutters



Ideal for hitting stamps and making readable marks, this **2 LB STAMPING HAMMER** has an 8" shaft for easy control.

P/N	DESCRIPTION
SH2	Stamping Hammer



Channellock® LOCKNUT PLIERS are designed for quick, easy adjustment of electrical locknuts and **GVNUT**. Their thin profile is ideal for use in tight wire-confined electrical boxes, and they have spring-loaded locking handles that fit 1/2", 3/4", 1", 1 1/4", and 1 1/2" locknuts.

P/N	DESCRIPTION
TL960	8 1/2" Locknut Pliers

Featuring **Titanium Bonded®** blades that are three-times harder than steel, these **TI STRAIGHT SNIPS** stay sharper longer and resist corrosion and adhesives. Plus their top blade is micro-serrated for true "grip and cut" performance. Ergonomic glass-filled nylon handles add comfort, while their spring-assisted action reduces hand fatigue. Other features include an internal locking mechanism and integrated wire cutter.

P/N	DESCRIPTION
TL18039	8" Straight Snips



With their multi-purpose design, these **AVIATION SNIPS** cut straight and wide curves on sheet metal, vinyl, plastic, and rubber. They feature **Pro-Touch™ Grips** for comfortable handling with less fatigue. Polished alloy blades give them a high-quality finish, while a positive lock-space safety latch keeps them closed.

P/N	DESCRIPTION
TL103	10" Aviation Snips



Craftsman's Handi-Cut® UTILITY CUTTERS offer alloy steel construction with integrated in-handle blade storage. Their super-sharp 3 7/8" stainless blade easily slices through leather, rubber hose, plastic, and more. Handle latch and extra blade are standard.

P/N	DESCRIPTION
TL00937301	Utility Cutters
TL00937253	Replacement Blade For TL00937301



In Use photos may show items not included or available separately.



These **RESCUE TOOLS**, from **Channellock**, have a spanner wrench that works on storz and rocker lug couplings (up to 5"). There is a tool steel punch to shatter safety glass, a pry bar for doors and windows, a gas shutoff, and a cable cutter with hardened steel blades that easily shear through soft metal or battery cables. Their narrow profiles work great in tight places.

P/N	DESCRIPTION
TL87	9" 87 Rescue Tool
TL89	11" 89 Rescue Tool



Crescent® SCREWDRIVERS feature tool steel construction with ergonomic handles. The **TL053**, **TL074**, and **TL0106** cover all commonly used slotted screws, while the **TL034** and **TL024** cover all commonly used **Phillips®** head screws.

P/N	DESCRIPTION
TL053	3/16" x 3" Slotted Screwdriver
TL074	1/4" x 4" Slotted Screwdriver
TL0106	5/16" x 6" Slotted Screwdriver
TL034	#1 x 4" Phillips Screwdriver
TL024	#2 x 4" Phillips Screwdriver



Crescent's 4-PIECE DUAL-MATERIAL SCREWDRIVER SET features chrome-plated blades to prevent corrosion and ergonomic handles for ease in applying high-end torque.

P/N	DESCRIPTION
TLSDS	4-Piece Screwdriver Set Includes: 3/16" x 3", 1/4" x 4" Slotted; #1, #2 Phillips

Crescent's 5-PIECE NUTDRIVER SET comes with cushioned red handles that are designed for comfort and performance. Chrome-plated.

P/N	DESCRIPTION
TLDDS	5-Piece Nutdriver Set Includes: 3/16", 1/4", 5/16", 3/8", 7/16"



The **Crescent® Dura-Driver™ RATCHETING DRIVER SET** features magnetic shafts with 1/4" hex drives, three torque positions (fwd/lock/rev), in-handle bit storage, and a carry case.

P/N	DESCRIPTION
MBR2	34-Piece Ratcheting Driver Set Includes: 3/16", 1/4", 5/32", 5/16", 11/32", 3/8", 7/16", 5-11mm Nutdrivers; #1, #2, #3 Phillips; 1/4", 5/32", 3/16" Slotted; #1, #2, #3 Square Recess; Bit Holder w/ 1/4" Hexdrive; TX6, TX8, TX10, TX15, TX20, TX25, Torx; 1/4", 5/32", 3/16" Hex & Carry Case

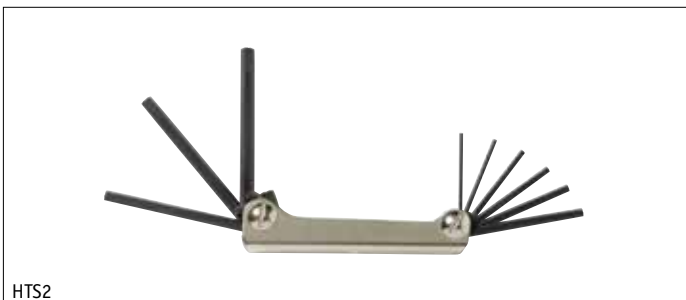

These fold-up **HEX TOOLS** feature casings made from high-tech nylon resin, with heat-treated premium 8650 alloy steel blades, finished in black oxide for excellent rust resistance. Their unique Z-fold design allows easy access to all keys. Blades are marked with their hex size for quick identification.

P/N	DESCRIPTION
HTS1	9-Piece Hex Tool Set, Medium Includes: 1/20", 1/16", 3/64", 3/32", 7/64", 1/8", 9/64", 5/32", 3/16"
HTS2	9-Piece Hex Tool Set, Large Includes: 5/64", 3/32", 7/64", 1/8", 9/64", 5/32", 3/16", 7/32", 1/4"

The **Craftsman® Professional 21-PIECE DRILL BIT SET** is ideal for heavy-duty use on all metals, including hard types. Bits come with split tips that drill on contact for less "walking" and a plastic case to keep them organized.

P/N DESCRIPTION
 21PDBS 21-Piece Drill Bit Set
 Includes: 1/16"-3/8" by 64ths

Made of M2 high-speed steel, these **GENERAL-PURPOSE DRILL BITS** resist heat build-up with better penetration. They are fractional sized with 118° standard points and straight shanks, making them ideal for metal, wood, and plastic.

P/N DESCRIPTION
 DBS1 General-Purpose Drill Bits
 Includes: 1/16"-1/2" by 32nds

This **FLARING TOOL** efficiently flares the pipe ends of seven common sizes (3/16"-5/8"). Ideal for copper and soft aluminum tubing.

P/N DESCRIPTION
 TL2880 Flaring Tool

The **Lenox® HEAVY-DUTY HACKSAW** features lightweight all-metal construction, a large throat area for maximum cut depth, and an enlarged handle-grip opening. Its unique design prevents its blade from being over tensioned. Saw comes complete with a 12" bi-metal blade.

P/N DESCRIPTION
 TL2012 Hacksaw
 TL224 Hacksaw Blade, 12" x 24 Tooth

Gerber's Legend MP800™ MULTI-PLIER features replaceable tungsten carbide wire cutter inserts, a **RemGrit®** blade, scissors, cushioned handle grips, needle-nose pliers, wire cutters, knife blade, cross-head screwdriver, and small, medium, and large slotted screwdrivers, a bottle opener, and a file. Tool measures 6 7/8" open, 4 1/4" closed, and weighs 9.8 oz. Includes ballistic nylon sheath.

P/N DESCRIPTION
 8239F Legend Multi-Plier

The **MP600 Pro Scout™ MULTI-PLIER**, from **Gerber**, utilizes a universal coupler with a premium **RemGrit®** blade and features flip-open needle-nose pliers. It comes with wire cutters, a Standard/Metric scale, cross-head screwdriver, bottle and can opener, crimper, small and medium slotted screwdrivers, file, scissors, and serrated knife. Tool measures 6 5/8" open, 5 1/8" closed, and weighs 9 oz. Includes ballistic-nylon sheath.

P/N DESCRIPTION
 7563F Pro Scout Multi-Plier



21PDBS



DBS1



TL2880



TL2012

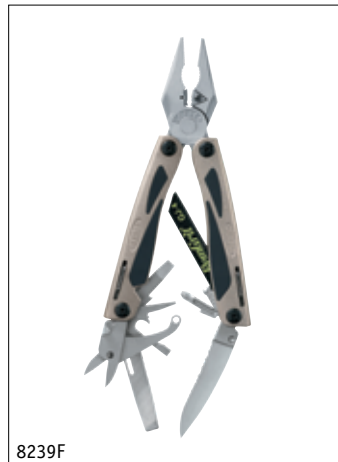

8239F

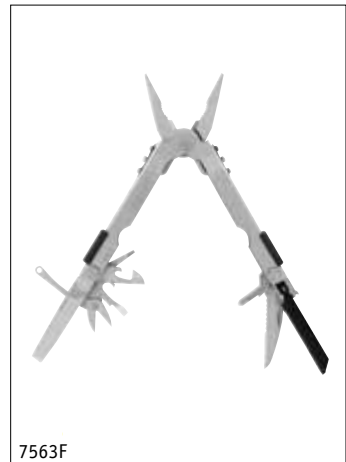

7563F



LS105

LABEL SCRAPERS come in either retractable or fixed versions for rapid material removal and feature easy blade exchange.

P/N	DESCRIPTION
LS105	Label Scraper w/ Razor Blade
SB109	Razor Blades, Pkg/100
HS690	Hood Grease Scraper, 4" Blade w/ 9" Steel Handle
SB698	Grease Scraper Blades, Pkg/10 For HS690
HS723	Folding Razor Scraper



HS690



HS723

Cartridge-based, the **SpeedPak Ti UTILITY KNIFE** offers quick, easy, and safe blade changes. It stays sharper longer, thanks to its **Titanium Bonded®** double-edged blade that is three-times harder than steel. Knife is constructed from lightweight aluminum with a nonslip grip and includes one blade. Gray.



TL18038

P/N	DESCRIPTION
TL18038	Ti Utility Knife
TL18089	Ti Replacement Blades, Pkg/10



TL316

These **UTILITY** and **SAFETY KNIVES** help prevent accidents, saving lost time at work from injuries. The **TL316** comes with three blades and a blade auto lock for extra protection against accidental opening. The **K310** has an automatic spring-action safety guard that covers the blade. Its chrome-plated zinc handle stores two extra blades.

P/N	DESCRIPTION
TL316	Utility Knife
TL6100RB	Replacement Blades, Pkg/10 For TL316
K310	Lewis Safety Knife



K310

This **FOLDING KNIFE**, from **Camillus**, is made of VG-10 Japanese steel and **Carbonitride Titanium**. This means the knife blades will not chip, blister, peel, or flake. Being about ten-times harder than untreated steel, they stay sharper longer. Knife comes standard with G10 handle.



18670

P/N	DESCRIPTION
18670	Folding Knife w/ Marlin Spike, 6 1/2" (Open)

The **E-Z Out™ SERRATED KNIFE**, from **Gerber**, has **Softgrip®** inserts in its handle for a positive, comfortable grip and easy one-handed operation. It comes with a removable stainless steel pocket clip. Weighs 2.6 oz, is 4 9/16" closed, and 7 7/8" open.



KN6751

P/N	DESCRIPTION
KN6751	E-Z-Out Knife

Gerber's Applegate-Fairbairn™ Covert™ DOUBLE BEVEL SERRATED KNIFE features effortless one-handed operation (right or left) and includes a removable, reversible stainless steel pocket clip. The patented locking system keeps its blade open or locked closed. Knife measures 4 7/8" closed, 8 13/16" open, and weighs 4.2 oz.



KN5785

P/N	DESCRIPTION
KN5785	Covert Knife

The **BucketBoss® HOLSTER** incorporates dense foam padding to protect your mobile device and a stainless steel spring clip for carry convenience. Fits up to an **iPhone 7**.

P/N	DESCRIPTION	H X W X D
CPH2	Cell Phone Holster	6 1/2" x 3 1/4" x 1 1/2"



The **Arsenal® UTILITY KNIFE/HOLE PUNCH HOLSTER** features ballistic polyester construction, a stainless steel belt clip, and two pen/pencil pockets.

P/N	DESCRIPTION	H X W X D
HPH	Utility Knife/Hole Punch Holster	9" x 2" x 1"



The **StudSensor™ Pro SL-AC STUD FINDER** locates the edges of wood and metal studs and joists behind walls, ceilings, and floors (up to 3/4" in **Stud Scan** mode or up to 1 1/2" in **DeepScan®** mode). It features precise, instantaneous **TruCal®** calibration to any wall density; a recessed LED display; and an audio signal to pinpoint stud edges. **WireWarning® Detection** continuously detects "hot" unshielded electrical wires (up to 2" deep).

P/N	DESCRIPTION
STUD2	AC Stud Finder

This professional-grade **Hi-Viz® TAPE MEASURE** has bold, clearly printed numbers on a bright-yellow tape with fractional graduations. Its rigid blade is acrylic coated, and its durable case fits comfortably in the hand for better control and impact absorption. Comes standard with a steel belt clip. 1" x 25'. Orange.

P/N	DESCRIPTION
TL125	Tape Measure



Built around a solid aluminum frame, this **TORPEDO LEVEL** features a powerful magnetic edge for hands-free use. Its durable acrylic vials read plumb, level, and 45°.

P/N	DESCRIPTION
TL9919	9" Torpedo Level



Quickly check any CO₂ hose (per NFPA 10) with our **CO₂ HOSE CONTINUITY TESTERS**.

NOTE: Remove hose from extinguisher and place on a non-conductive surface before testing.

P/N	DESCRIPTION
CHT	CO ₂ Hose Continuity Tester w/o Batteries
NCHT	CO ₂ Hose Continuity Tester w/ Batteries





FH8512

MISCELLANEOUS SUPPLIES AND STORAGE

Brooks' FORM HOLDER secures and organizes loose forms, invoices, work orders, and more. Its swivel bar clip and writing plate make it easy to fill out invoices and other forms. Measures 8½" x 12".

P/N	DESCRIPTION
FH8512	Form Holder

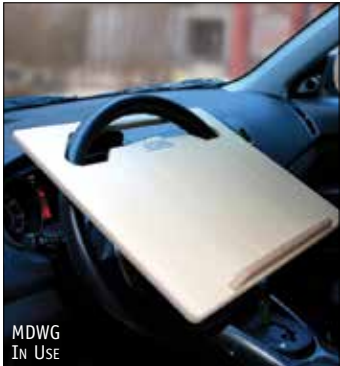

MDWG
IN USE



MDWG
IN USE

Perfect for those who use their vehicle as an office, this **NOTEBOOK MOBILE DESK** provides a comfortable writing surface and installs over any 16" steering wheel in seconds. Works with laptops. Measures 15¼" x 13½".

P/N	DESCRIPTION
MDWG	Mobile Desk



19022EG

Squids' TOOL LANYARDS keep tools at hand and help to prevent injury and lost productivity. They are made of stretchable cord, surrounded by tubular nylon webbing, with reflective stitching. They offer a full range of motion (35"–42") with a 10 lb maximum working capacity.

P/N	DESCRIPTION
19002EG	Tool Lanyard, Single Carabiner, Standard, Black
19012EG	Tool Lanyard, Single Carabiner, Extended, Black
19022EG	Tool Lanyard, Dual Carabiner, Standard, Black
19023EG	Tool Lanyard, Dual Carabiner, Standard, Lime

Squids' COILED CABLE LANYARDS' swiveling design prevents tangles and reduces recoil forces, preventing aggressive snap back, and they keep their length close to the anchoring point, reducing snag hazards.

P/N	DESCRIPTION
19130EG	Coiled Lanyard, 6½"–50", 2 lb Working Capacity, Lime
19131EG	Coiled Lanyard, 7"–51", 5 lb Working Capacity, Orange



19130EG



18336EG

The **Proflex® 335HL SLIP-RESISTANT RUBBER CAP KNEE PAD** grips the work surface for stability. Its 840-denier nylon fabric features ½" NBR foam padding and contoured side cuts for greater knee motion. Woven elastic straps adjust for an exact fit. One size. Black.

P/N	DESCRIPTION
18336EG	Slip-Resistant Knee Pad

Non-conductive, petroleum resistant, and silicone-free, this **Proflex® STANDARD KNEELING PAD** features 1" closed cell foam for outstanding comfort and a handle for easy carry. 14" x 21". Black.

P/N	DESCRIPTION
18380EG	Kneeling Pad



18380EG

The **Proflex® neoprene ELBOW SLEEVE** is perforated for enhanced breath ability with spandex mesh in the elbow for a more comfortable fit. Its contoured ambidextrous design conforms to the body's natural shape. Medium. Black.

P/N	DESCRIPTION
16573EG	Elbow Sleeve



16573EG In Use



16004EG In Use

Offering flexibility and effective pain relief from repetitive arm movements, this **Proflex® ELBOW SUPPORT** features neoprene four-way stretch fabric that directs pressure away from the tendons of the forearm. Its contoured design offers a wide base of support for improved performance. Machine washable. Large. Black.

P/N	DESCRIPTION
16004EG	Elbow Support

The **BucketBoss® BUCKET ORGANIZER** turns any 5 gal bucket into an instant tool caddy with 30 pleated pockets for smaller items and an open center for larger ones, while the **STACKER SYSTEM** organizes with four compartments, a drill bit sizer, pencil holder, and 4" ruler. The **BUCKET SEAT** works on any 5 gal bucket, turning it into a handy place to sit and store things (includes a clear cover, six compartments, and carry handle.)

P/N	DESCRIPTION
JB24	Bucket Organizer, Brown/Green
BKBIN	Stacker System, Yellow
BSEAT	Bucket Seat, Red



JB24 In Use



BKBIN In Use

The lightweight, 11-pocket **BucketBoss® TOOL BELT** is ideal for extinguisher technicians. It holds tags, punches, seals, a rubber mallet, and more. Includes a fully adjustable belt with a quick-release buckle. One size. Brown/Green.

P/N	DESCRIPTION
BELT1	Tool Belt



BELT1 In Use

BucketBoss® GateMouth® TOOL BAGS feature padded sides that protect tools, while its rigid bottom retains its shape. It has 16 pockets, and will not scratch surfaces or rust like metal tool boxes. Adjustable shoulder strap included. Brown/Green.

P/N	DESCRIPTION	L X H X W
GTB2	GateMouth Jr. Bag	12" x 9" x 7"
GTB1	GateMouth Bag	16" x 12" x 9"



GTB2

In Use photos may show items not included or available separately.



CBC1



CBC2

BucketBoss® CONTRACTOR'S BRIEFCASE and **PORTFOLIO** work as a mobile office. The **Contractor's Briefcase** has plenty of room for plans, file folders, notebooks, basic tools. The **Contractor's Portfolio** has numerous pockets of its own. Organizers are constructed from heavy, 600-denier polyester fabric for years of dependable service. Brown/Green.

P/N	DESCRIPTION	L X H X W
CBC1	Contractor's Briefcase	16" x 12½" x 6"
CBC2	Contractor's Portfolio	15" x 12" x 4"



SSB20 In Use

The **Step 'N Stor® TOOL BOX** is made of sturdy co-polymer that will support up to 325 lb and features a sure-grip large carry handle, handy tote tray, and a deep-bottom storage area for supplies and tools. Lockable. Red.

P/N	DESCRIPTION	H X W X D
SSB20	Tool Box	12½" x 20" x 14"



LHTHM In Use

Squids® TIE HOOKS provide a versatile, innovative solution to the problem of securing and storing awkward items, like cords, cable, hoses, wires, and more. Reusable and long lasting, these tie hooks are resistant to oil, salt, solvents, and alkali. With 360° of rotation, they offer easy access from any angle. Hook end has a 1½" opening. Hi-Vis Orange.

P/N	DESCRIPTION	CAPACITY
LHTHS	Large Locking Tie Hook, Short (11 ⁸ / ₁₆ " Belt)	44 lb
LHTHM	Large Locking Tie Hook, Medium (15 ⁸ / ₁₆ " Belt)	44 lb
LHTHL	Large Locking Tie Hook, Long (19 ⁸ / ₁₆ " Belt)	44 lb



19142EG In Use

Squids® GRABBERS clip to just about anything—clothing, straps, tool belts, D-rings, and more, so gloves, hats, glasses, etc., are right where you need them. They are lightweight, durable, metal detectable, and safe to use, thanks to a "breakaway" feature. Deep Blue.

P/N	DESCRIPTION
19132EG	Grabbers, Dual Clip
19142EG	Grabbers, Belt Clip



19142EG

The five-drawer **PARTS BIN RACK SYSTEM** stores and organizes O-rings, rivets, fusible links, and more. Bin rack and bin boxes sold separately.

P/N	DESCRIPTION
PBR1	Bin Rack, Gray
LPC16	Bin Box, 16 Compartments, Clear
LPC24	Bin Box, 24 Compartments, Clear



PBR1 w/ LPC16 IN USE

Designed to secure loads in truck beds, the **Save-A-Load® CARGO BAR** features a maintenance-free pump with a push-button instant release and pressure-limiting valve. Pivoting feet and ultra-gripping rubber pads enable it to safely grip most any surface. Bar adjusts from 47" to 75" and will not rust or corrode.

P/N	DESCRIPTION
PUCB	Cargo Bar



PUCB

This **SINGLE CYLINDER HAND TRUCK** is perfect for medium-to-large cylinders and can be used to transport boxes or other bulky items. Includes a heavy-duty holding chain. Green.

P/N	DESCRIPTION	L X H X W
CYLTRK1	Hand Truck	48" x 14" x 7"



CYLTRK1

CYLTRK1 IN USE

The **ProCart™** is a versatile 2-shelf plastic **UTILITY CART** with side gates (on both the upper and lower shelves) that flip down, converting it from a box-top to a flat-top. Its tough high-density polyethylene structural foam construction makes it virtually indestructible, and it is easy to maneuver—even loaded. 400 lb capacity. Gray.

P/N	DESCRIPTION	L X H X W
30936GREY	Utility Cart	45 ⁵ / ₈ " x 34 ³ / ₄ " x 24"



30936GREY

This heavy-duty **2-SHELF UTILITY CART** features sturdy yet lightweight structural-foam construction that will not rust, dent, or peel, making it ideal for any work environment. Each shelf can hold up to 250 lb (for a total capacity of 500 lb), while an ergonomically designed push handle provides optimum hand placement and push height, improving control and worker safety. Black.

P/N	DESCRIPTION	L X H X W
450088BK	2-Shelf Utility Cart	39" x 33 ³ / ₁₆ " x 17 ⁷ / ₈ "



450088BK



SPR24 In Use



PB24

These **TRIGGER SPRAYERS** are for general-purpose applications and fit the polyethylene **PLASTIC BOTTLES**, which come with graduations and dilution ratios.

P/N	DESCRIPTION
SPR24	Trigger Sprayer, 8 ¹ / ₄ " Tube
SPR32	Trigger Sprayer, 10" Tube
PB24	Plastic Bottle, 24 oz
PB32	Plastic Bottle, 32 oz



FT2



FP2B

TRAINING KIT

The **FIRE TRAINING TORCH KIT** provides an ignition and smoke source to monitor ground-level wind currents in and around raw-fuel vapor areas. It offers a visual means for safely positioning students and instructors upwind during training exercises. Each kit includes brackets and wick and accommodates most standard automobile oil filters for burning kerosene or #2 fuel oil.

P/N	DESCRIPTION
FT2	Torch Kit
FT2W	Replacement Wick
FP2B	2B-Rated Fire Pan w/ Drain Plug, 27"L x 27"W x 4"D



TRUFORCE INDUSTRIAL ALKALINE BATTERIES

BATTERIES AND FLASHLIGHTS

TruForce® Industrial ALKALINE BATTERIES are long-lasting, low-cost alternatives with the power to run all of your devices. Batteries have up to a 10-year shelf life.

P/N	DESCRIPTION
TFAAB	AA Alkaline Batteries, Pkg/4
TFAAAB	AAA Alkaline Batteries, Pkg/4
TFCB	C Alkaline Batteries, Pkg/2
TFDB	D Alkaline Batteries, Pkg/2
TF9VB	9V Alkaline Battery



ENERGIZER ALKALINE BATTERIES



E91BP4

Energizer® Industrial® ALKALINE BATTERIES are designed for heavy-current or continuous-use applications. They operate well in extreme temperatures (0°F to 130°F) with an excellent shelf life. Alkaline cells can even be used after 10 years of storage.

P/N	DESCRIPTION
ALK91*	Industrial AA Alkaline Battery
ALK92*	Industrial AAA Alkaline Battery
ALK93	Industrial C Alkaline Battery
ALK95	Industrial D Alkaline Battery
ALK22	Industrial 9V Alkaline Battery

*AA AND AAA BATTERIES MUST BE PURCHASED IN QUANTITIES OF 4

Energizer® Max® ALKALINE BATTERIES are designed for long-lasting performance in a broad spectrum of devices. They have a long shelf life—10 years—so they are fresh when needed. Mercury-free.

P/N	DESCRIPTION
E91BP4	Max AA Alkaline Batteries, Pkg/4
E92BP4	Max AAA Alkaline Batteries, Pkg/4
E93BP2	Max C Alkaline Batteries, Pkg/2
SL65030	Max AAAA Alkaline Batteries, Pkg/6



E93BP2

In Use photos may show items not included or available separately.

This **Energizer® Ultimate Lithium® 9V BATTERY** is 25% lighter with up to two-times the shelf life of an alkaline. Operating in all temperature extremes (-40°F to 140°F), it can last up to 10 years as a backup in AC-powered smoke detectors. Complies with ANSI 9V dimensional specs for alkaline and lithium batteries.

P/N	DESCRIPTION
L522EN*	Ultimate Lithium 9V Battery
	*UNAVAILABLE IN AK, HI, PR, OR CATALINA

Pelican's HeadsUp Lite™ LED HEADLIGHT comes with a rotary bezel switch and adjustable cloth and heavy-duty rubber straps. It is made of impact- and chemical-resistant ABS and is weather-resistant as well as intrinsically safe. Class I, II, III, Division 1 rated, and IPX7 waterproof to 1 m for up to 30 minutes. Three AAA alkaline batteries included. 2¹³/₁₆". Black.

P/N	DESCRIPTION
P2690BK	HeadsUp LED Headlight
	74 Lumens; 11 hr Runtime
TFAAAB	AAA Alkaline Batteries, Pkg/4

This **LED HEADLIGHT**, from **Pelican**, features **Gesture Activation Control Technology**, enabling it to turn on with the wave of a hand. A low-level red light for night vision, a Signaling Red (S.O.S.) Beacon light, a rubber head strap, and optical 4x magnification are standard. IPX4 water resistant. Includes three AAA alkaline batteries. 2¹/₂". Black.

P/N	DESCRIPTION
P2720BK	LED Headlight
	200 Lumens (High Mode); 103 hr Runtime (Low Mode)
TFAAAB	AAA Alkaline Batteries, Pkg/4

Energizer's Vision LED HEADLIGHT offers hands-free operation with two light modes that control brightness and runtime, making it up to four-times brighter than standard LEDs. It comes with a pivoting head, slide switch, and three AAA batteries. Impact resistant to 1 m. 1³/₈". Blue.

P/N	DESCRIPTION
HDA32E	Vision LED Headlight
	100 Lumens; 7 hr Runtime
TFAAAB	AAA Alkaline Batteries, Pkg/4

Offering tool-quality construction, with advanced LED technology, **Energizer's Hard Case Professional® MAGNET HEADLIGHT** has a detachable magnetic head for metal-mounting. It comes standard with Spot and Flood light settings, a nonslip head strap, removable top strap, and three AAA **Energizer® Max®** batteries. IPX4 water resistant. 1³/₄". Black.

P/N	DESCRIPTION
HCHDM32E	Hard Case Magnet Headlight
	250 Lumens; 3.75 hr Runtime
TFAAAB	AAA Alkaline Batteries, Pkg/4



L522EN



P2690BK



P2720BK



HDA32E



HCHDM32E



SL61050



SL61400

Streamlight's Trident® and Enduro® LED HEADLAMPS provide superior hands-free lighting. The **Trident Headlamp** features four LEDs (one being a **C4**), a 90° tilting head, and three-way lighting for short, medium, and long distances (with Spot-to-Flood adjustment). The lightweight **Enduro Headlamp** features High and Low lighting modes, a 0.5 W high-flux LED, and O-ring sealed construction. Both headlamps have polycarbonate bodies and adjustable elastic/rubber combo head straps. **Trident** is IPX4 water resistant. **Enduro** is IPX7 waterproof to 1 m for 30 minutes. And each is impact resistant to 2 m. Three AAA batteries included.

P/N	DESCRIPTION
SL61050	Trident LED Headlamp, Orange/Black/Yellow, 1 7/8" 80 Lumens (High Mode); 53 hr Runtime (Low Mode)
SL61400	Enduro LED Headlamp, Black, 1 5/8" 50 Lumens (High Mode); 25 hr Runtime (Low Mode)
TFAAAB	AAA Alkaline Batteries, Pkg/4



P2380BK

Tactically oriented, this **Pelican LED FLASHLIGHT** is made of Type II anodized aluminum for extra toughness. It is Spot-to-Flood-light capable and features **Slide-Beam Technology** for easy light adjustment. It includes a built-in battery level indicator and a steel clip to keep it close. IPX7 waterproof to 1 m for up to 30 minutes. Comes with two AA alkaline batteries. 6 7/16". Black.

P/N	DESCRIPTION
P2380BK	Tactical LED Flashlight 372 Lumens (High Mode); 13 hr Runtime (Low Mode)
TFAAB	AA Alkaline Batteries, Pkg/4



P2410Y

Another great light, from **Pelican**, the **StealthLite™ LED FLASHLIGHT** is corrosion proof, extreme-temperature resistant, and submersible. It offers the brightness of a xenon bulb but with the battery life of a LED. Intrinsicly safe, it comes standard with a one-handed flip switch and four AA alkaline batteries. Class I, II, III, Division 1 rated and IPX7 waterproof to 1 m for up to 30 minutes. 7". Yellow.

P/N	DESCRIPTION
P2410Y	StealthLite LED Flashlight 183 Lumens; 5.75 hr Runtime
TFAAB	AA Alkaline Batteries, Pkg/4
E91BP4	Max AA Alkaline Batteries, Pkg/4



PLED23A

Energizer's metal LED PENLIGHT is small and portable, featuring a push-button switch for one-handed operation and a sturdy clip to help keep it close. A super-bright LED provides strong light in an easy-to-use format, while two **Energizer® Max®** AAA alkaline batteries provide the power. Impact resistant to 1 m. 5 5/8". Silver.

P/N	DESCRIPTION
PLED23A	Metal LED Penlight 35 Lumens; 20 hr Runtime
TFAAAB	AAA Alkaline Batteries, Pkg/4

Streamlight® Stylus® PENLIGHTS clip to your shirt pocket and feature a 100,000-hour LED that you can switch from Constant-On to Momentary Blink with the click of a button. They have a knurled anodized aluminum body and use three AAAA-cell batteries (included). IPX4 water resistant. Black.

P/N	DESCRIPTION
SL65018	Stylus Penlight, 6 ³ / ₁₆ " Long 11 Lumens; 24 hr Runtime
SL65618	Stylus Reach Penlight, 14" (Extended), 6 ³ / ₄ " (Folded) 11 Lumens; 24 hr Runtime
SL65030	AAAA Replacement Batteries, Pkg/6



SL65618

Featuring **Streamlight's** proprietary **Micro Optical System (MOS)**, the **MicroStream® PENLIGHT** uses a 30,000-hour **C4®** LED that provides up to 45 lumens of bright light. It has an aircraft aluminum housing for added toughness. Other features include an internal polymer liner, shockproof switch, O-ring seal, and an unbreakable polycarbonate lens. Runs on one AAA alkaline battery (included). IPX4 water resistant. 3¹/₂". Black.

P/N	DESCRIPTION
66318	MicroStream Penlight 45 Lumens; 2.25 hr Runtime
TFAAAB	AAA Alkaline Batteries, Pkg/4



66318

Energizer's Vision HD PERFORMANCE METAL FLASHLIGHT comes with custom optics for exceptional direct and peripheral vision and is LED color aligned with natural daylight. It also comes standard with digital switching for High, Power-Saver, and Emergency Strobe modes. Made of commercial-grade aluminum alloy and includes six AA **Energizer® Max®** batteries. IPX4 water resistant and impact resistant to 1 m. Black.

P/N	DESCRIPTION
→ EPMZH61E	Vision HD Performance Metal Flashlight 1300 Lumens; 4 hr Runtime
TFAAB	AA Alkaline Batteries, Pkg/4



EPMZH61E

Streamlight's Stylus Pro® PENLIGHT features **C4®** LED technology for blindingly bright light; compact, durable construction; optimum beam output; and a tailswitch for single-handed operation. Corrosion and IPX4 water resistant, it is shockproof and O-ring sealed with an unbreakable lens and includes two AAA alkaline batteries. 5⁵/₁₆". Black.

P/N	DESCRIPTION
66118	Stylus Pro Penlight 90 Lumens; 11 hr Runtime
TFAAAB	AAA Alkaline Batteries, Pkg/4



66118



EVEL25IN

Dependable and affordable, **Eveready's GENERAL PURPOSE LED FLASHLIGHT** features a ribbed design for a secure, nonslip grip. It shines up to five-times brighter than ordinary LED flashlights and comes standard with a push-button switch. 7¹/₈". Red. Batteries not included.

P/N	DESCRIPTION
EVEL25IN	2D LED Economy Flashlight 25 Lumens; 120 hr Runtime
TFDB	D Alkaline Batteries, Pkg/2



MS2DLED

Energizer® Intrinsicly Safe® LED SAFETY FLASHLIGHTS help eliminate risk to workers in potentially hazardous situations. These lights are IP67 waterproof and dustproof and can survive a 1 m drop test. They come standard with shatterproof lenses, large button switches, and built-in carabiners. Class I, Division 1 rated. Orange.

P/N	DESCRIPTION
MS2DLED	2D LED Safety Flashlight, 7 ¹⁵ / ₁₆ " 60 Lumens; 135 hr Runtime
MS2AALED	2AA LED Safety Flashlight, 6" 65 Lumens; 21 hr Runtime
TFDB	D Alkaline Batteries, Pkg/2
TFAAB	AA Alkaline Batteries, Pkg/4
E91BP4	Max AA Alkaline Batteries, Pkg/4



HCSW21E

The water resistant **Energizer® PIVOTPRO FLASHLIGHT** offers 175° of aimable light. It features tool-quality construction with advanced LED technology. Comes with a magnetic base for hands-free use and two AA **Energizer® Max®** batteries. IPX4 water resistant and 7 m drop tested. 9³/₄". Black/Gray.

P/N	DESCRIPTION
HCSW21E	PivotPro 2AA Flashlight 300 Lumens; 5 hr Runtime
TFAAB	AA Alkaline Batteries, Pkg/4



HCSP61E

The **Energizer® Hard Case Professional® LED SPOTLIGHT** is suited for long-distance lighting applications, thanks to its tight white beam that is intensely focused. Weatherproof, IPX4 water resistant, and impact-resistant to 7 m, its nonslip pistol grip and trigger switch make it easy to operate. Comes with a removable clip and six AA **Energizer® Max®** batteries. 12". Black/Gray.

P/N	DESCRIPTION
HCSP61E	Hard Case LED Spotlight 600 Lumens; 6.25 hr Runtime
TFAAB	AA Alkaline Batteries, Pkg/4

Intrinsically safe, the **RIGHT ANGLE LED FLASHLIGHT**, from **Pelican**, offers four lighting modes—High, Low, Flashing, and Downcast. It comes with a built-in battery life indicator for at-a-glance power readings, a clip for hands-free operation, and a tethered battery door. Class I, Division 1 approved. IPX4 water resistant. Requires four AA alkaline batteries (not included). 5³/₈". Yellow.

P/N	DESCRIPTION
P3715Y	Right Angle LED Flashlight 233 Lumens (High Mode); 31 hr Runtime (Downcast Mode)
TFAAB	AA Alkaline Batteries, Pkg/4
E91BP4	Max AA Alkaline Batteries, Pkg/4



P3715Y

This **RECHARGEABLE RIGHT ANGLE LED FLASHLIGHT** shares many features with other **Pelican™** flashlights, like High, Low, Downcast, and Flashing light modes. Where it differs is in what it runs on—four alkaline AA batteries or a rechargeable battery pack (both included). It is made of ABS, making it light yet rugged, and it is intrinsically safe. Class I, Division 1 rated (with alkaline batteries) and Class I, Division 2 (with rechargeable battery pack). NFPA 1901 compliant and IPX4 water resistant. 5³/₈". Yellow.

P/N	DESCRIPTION
P3765Y	Rechargeable Right Angle LED Flashlight w/ 120 VAC/12–24V Fast Charger 237 Lumens (High Mode); 14 hr Runtime (Downcast Mode)
TFAAB	AA Alkaline Batteries, Pkg/4
E91BP4	Max AA Alkaline Batteries, Pkg/4



P3765Y

Offering magnetic attachment, **Energizer's Hard Case Professional® LED WORK LIGHT** uniformly lights up areas with two optimized LED modes that offer better runtime and beam distance. IPX4 water resistant, impact resistant to 7 m, and includes four AA **Energizer® Max®** batteries. 13¹³/₁₆". Black.

P/N	DESCRIPTION
HCAL41E	Hard Case Work Light 550 Lumens; 8 hr Runtime
TFAAB	AA Alkaline Batteries, Pkg/4



HCAL41E

This lightweight **LED LANTERN**, from **Pelican**, has four LEDs with three lighting modes—High, Low, and Flashing—and its head rotates 120°. Other standard features include a battery status indicator and a shoulder strap, and it comes with one 7.2V lithium-ion battery. NFPA 1901 rated and IPX4 water resistant. 8³/₄". Yellow.

P/N	DESCRIPTION
P9410LY*	LED Lantern 1203 Lumens (High Mode); 10.5 hr Runtime (Low Mode)
	*Unavailable in AK, HI, PR, or Catalina



P9410LY



P9415Y

Powerful and lightweight, **Pelican's** intrinsically safe **RECHARGEABLE LED LANTERN** comes with four LEDs and three lighting modes—High, Low, and Flashing. A 120° rotating head, battery status indicator, shoulder strap, and four rechargeable "C" Ni-Mh batteries are standard. Class I, Division 1 rated and IPX4 water resistant. 8³/₄". Yellow.

P/N	DESCRIPTION
P9415Y*	Rechargeable LED Lantern 413 Lumens (High Mode); 12 hr Runtime (Low Mode)
	*Unavailable in AK, HI, PR, or Catalina



P9420XL

The **RECHARGEABLE LED WORK LIGHT KIT**, from **Pelican**, eliminates the hassle of finding power. Powerful, thanks to dual LEDs, it has High and Low lighting modes, a water resistant switch, and a battery indicator to keep track of its power usage. It recharges fast (2 hours), and it all comes in a blow-molded case that includes one lithium-ion battery, a DC vehicle charger, an AC main charger with transformer, a charging station, and a shoulder strap. 29" (closed), 62" (extended). Black.

P/N	DESCRIPTION
P9420XL*	ProGear Work Light Kit 1000 Lumens (High Mode); 4 hr Runtime (Low Mode)
	*Unavailable in AK, HI, PR, or Catalina



P9480Y

This **REMOTE AREA LIGHTING SYSTEM**, from **Pelican**, offers three preset light levels—High, Medium, and Low with Flashing—and a deployable mast that rotates 340° for maximum coverage. It uses eight **High Flux** LEDs for blindingly bright light, while a **Bluetooth® iPhone® App** controls multiple units. Other features include a battery status indicator, shoulder strap, and 12V rechargeable battery. 10¹/₄" (closed), 23³/₄" (extended). Yellow.

P/N	DESCRIPTION
P9480Y	Remote Lighting System 4000 Lumens (High Mode); 28 hr Runtime (Low Mode)



P3610Y

Intrinsically safe, **Pelican's Little Ed™ RIGHT ANGLE LED FLASHLIGHT** features corrosion-proof ABS resin construction, making it immune to extreme temperatures. It uses **Deep Mount LED Technology** for outstanding light output and comes with a mounting clip and four AA alkaline batteries. Class I, II, III, Division 1 rated and IPX7 waterproof to 1 m for up to 30 minutes. 7¹/₂". Yellow.

P/N	DESCRIPTION
P3610Y	Little Ed Flashlight 183 Lumens; 5 hr Runtime
TFAAB	AA Alkaline Batteries, Pkg/4
E91BP4	Max AA Alkaline Batteries, Pkg/4

Waypoint® SPOTLIGHTS, from **Streamlight**, feature pistol grips and trigger switches that make them easy to point, shining powerful light on an exact spot. IPX4 water resistant, these spotlights have an integrated stand for hands-free lighting. Durably made, they have high-impact housings, **C4®** LEDs, and unbreakable lenses. Batteries sold separately. 7¹/₈".

P/N	DESCRIPTION
44900	Waypoint Spotlight w/ 12V Cord & Polymer Mount, Yellow 550 Lumens (High Mode); 82 hr Runtime (Low Mode)
44902	Waypoint Spotlight w/ 12V Cord & Polymer Mount, Black 550 Lumens (High Mode); 82 hr Runtime (Low Mode)
TFCB	C Alkaline Batteries, Pkg/2



44900

In a class by itself, the compact, super-bright **Stinger® FLASHLIGHT**, from **Streamlight**, is a lightweight, rechargeable, personal light that is virtually indestructible. Offering superior materials and craftsmanship, it is even serialized for positive identification. Standard features also include an LED charge-continuity indicator; a snap-in, universal-mount charger; and an anti-roll ring to keep it where you lay it. Its nickel-cadmium battery recharges up to 1000 times as well. IPX4 water resistant and impact resistant to 1 m. Black.

P/N	DESCRIPTION
→ SL75713	Stinger LED Flashlight w/ AC/DC Charger, 2 Holders 400 Lumens (High Mode); 7.25 hr Runtime (Low Mode)
SL75175	Replacement Battery (For SL75713)



→ NEW

SL75713

Pelican's LED KEYCHAIN LIGHTS are lightweight with aluminum construction and twist-on activation. They are IPX4 water resistant and come with four coin cell batteries. Lights offer 16 lumens and 8.5-hour runtimes. 1¹/₂".

P/N	DESCRIPTION
P1810BK	Keychain Light, Black
P1810BL	Keychain Light, Blue
P1810GD	Keychain Light, Gold
P1810R	Keychain Light, Red



P1810R



P1450BK

Featuring a polypropylene body with stainless steel hardware, padlock protectors, and O-ring seals, this **PROTECTOR CASE**, from **Pelican**, offers waterproof, crushproof, and dustproof protection. The case is easy to open, thanks to double-throw latches. Other standard features include a rubber over-molded handle and **Pick N Pluck™** foam for customizing its interior. IP67 rated (1 m submersion for 30 minutes). 14^{11/16}"L x 6^{1/8}"H x 10^{1/4}"W (ID). Black.

P/N	DESCRIPTION	L X H X W
P1450BK	Protector Case	16 ^{9/16} " x 6 ^{7/8} " x 13 ^{1/16} " (OD)



→ NEW

SL45855

E-Spot® LiteBox® LANTERNS, from **Streamlight**, come standard with three **C4®** LEDs that can throw concentrated, bright light over large areas at great distances. They also have swivel heads; optimized electronics for regulated intensity; and unbreakable, scratch-resistant lenses. Their mounting racks meet NFPA 1901 requirements in any position too. Rechargeable, zero-maintenance 6V, 12 Ah sealed lead acid batteries are standard as well. IPX4 water resistant. Orange.

P/N	DESCRIPTION
→ SL45851	E-Spot Litebox Standard System Flashlight 11 ^{1/4} "L x 7"H x 5 ^{3/32} "W Includes: 120 VAC, 12 V Chargers, Shoulder Strap & Mounting Rack, 540 Lumens (High Mode); 15 hr Runtime (Low Mode)
→ SL45855	E-Spot LiteBox Vehicle Mount System 11 ^{1/2} "L x 7"H x 5 ^{1/8} "W Includes: 12 V Charger, Shoulder Strap, 540 Lumens (High Mode); 15 hr Runtime (Low Mode)



→ NEW

SL44450

These **Fire Vulcan® CLASS I, DIVISION 2 LANTERNS** come with brilliant **C4®** LEDs as well as two ultra-bright blue LED taillights. Three-position toggle switches also make switching between Strobe and Steady modes quick and easy. Quick-release carry straps and mounting racks that meet NFPA 1901 requirements—in any position—are standard too. 7^{1/2}"L x 6^{1/2}"H x 5"W. Orange.

P/N	DESCRIPTION
→ SL44450*	Fire Vulcan Standard System Flashlight Includes 120 VAC, 12 V Chargers, Shoulder Strap & Mounting Rack, 180 Lumens (High Mode); 10 hr Runtime (Low Mode)
→ SL44451	Fire Vulcan Vehicle Mount System Flashlight Includes: 12 V Charger, Shoulder Strap & Mounting Rack, 180 Lumens (High Mode); 10 hr Runtime (Low Mode)

*UNAVAILABLE IN AK, HI, PR, OR CATALINA.



P3310ELS

This **EMERGENCY LIGHTING STATION**, from **Pelican**, is a self-contained glowing beacon and flashlight, housed in a clear tamperproof case that is wall mountable. When mounted, (hardware included) it offers easy access during power outages and has a **Signaling** mode for search and rescue scenarios. Uses three AA-cell alkaline batteries (included). IPX8 submersible to 100 m. 6^{1/8}". Photo luminescent.

P/N	DESCRIPTION
P3310ELS	Lighting Station 378 Lumens (High Mode); 202 hr Runtime (Low Mode)
TFAAB	AA Alkaline Batteries, Pkg/4

In Use photos may show items not included or available separately.



FIRE EXTINGUISHER PARTS



G100 (FRONT)



G100 (SIDE VIEW)



293266K (FRONT)



293266K (SIDE VIEW)



PG009RC (FRONT)



PG009RC (SIDE VIEW)



G100H (FRONT)



G100H (SIDE VIEW)



G100WS (FRONT)



G100WS (SIDE VIEW)

GAUGES

DRY CHEMICAL GAUGES. UL listed.

P/N	DESCRIPTION
G100	100 lb Dry Chemical Gauge
G125	125 lb Dry Chemical Gauge
G150	150 lb Dry Chemical Gauge
G175	175 lb Dry Chemical Gauge
G195	195 lb Dry Chemical Gauge
G235	235 lb Dry Chemical Gauge
G240	240 lb Dry Chemical Gauge
G350	350 lb Dry Chemical Gauge
G360	360 lb Dry Chemical Gauge

DRY CHEMICAL GAUGES. Kidde. UL listed.

P/N	DESCRIPTION
293266K	195 lb Kidde Dry Chemical Gauge
259535K	Kidde Gauge O-Ring, Plastic Valve ♦

DRY CHEMICAL GAUGES. RC Ind. UL listed.

P/N	DESCRIPTION
PG009RC	195 lb RC Ind Dry Chemical Gauge
OR7	O-Ring For RC Ind. Gauge

CLEAN AGENT GAUGES. UL listed.

P/N	DESCRIPTION
G100H	100 lb Halon 1211 Gauge
G125H	125 lb Halon 1211 Gauge
G195H	195 lb Halon 1211 Gauge
G100T	100 lb Halotron I Gauge
G125T	125 lb Halotron I Gauge

WATER-BASED EXTINGUISHER GAUGES. UL listed.

P/N	DESCRIPTION
G100WS	100 lb Water, Foam, & Loaded Stream Gauge
G100K	100 lb Wet Chemical Gauge

Designed specifically for removing and attaching most gauges, this cold-rolled, plated steel **GAUGE WRENCH** is $\frac{3}{16}$ " thick.

P/N	DESCRIPTION
GWRENCH	Gauge Wrench



GWRENCH

♦ Item in O-Ring Kit (ORKIT), see page 231.

VALVE STEMS

DRY CHEMICAL VALVE STEMS. Amerex. Pkg/5
(priced each).

P/N	DESCRIPTION
6092A	Amerex Valve Stems ♦
6093A	Amerex Valve Stems ♦

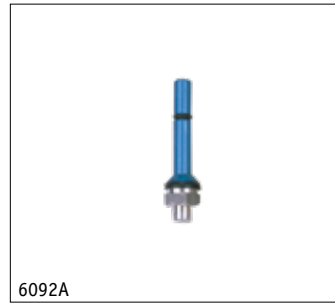

6092A

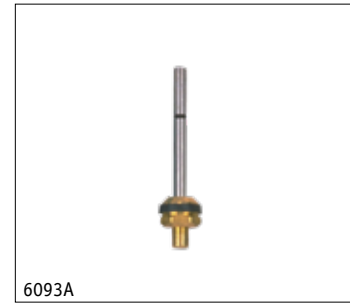

6093A

DRY CHEMICAL VALVE STEMS. Ansul. Pkg/5
(priced each).

P/N	DESCRIPTION
ASVS4	Valve Stems ♦ Comparable to 24489AS
ASVS5	Valve Stems ♦ Comparable to 54227AS
429099AS	Ansul Sentry Valve Stems ♦
428431AS	Ansul Sentry Valve Stems



ASVS4



ASVS5



429099AS



428431AS

DRY CHEMICAL VALVE STEMS. Badger. Pkg/5
(priced each).

P/N	DESCRIPTION
12426B	Badger Valve Stems ♦
19010B	Badger Valve Stems ♦
23389B	Badger Valve Stems ♦



12426B

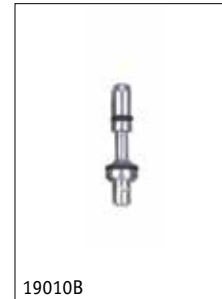

19010B

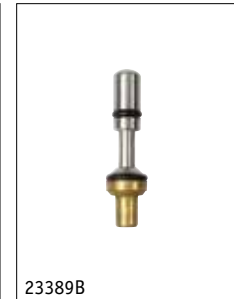

23389B

DRY CHEMICAL VALVE STEMS. Buckeye. Pkg/5
(priced each).

P/N	DESCRIPTION
103215W	Buckeye Valve Stems ♦
WVS13	Valve Stems Comparable to 100214W
WVS15	Valve Stems Comparable to 106214W

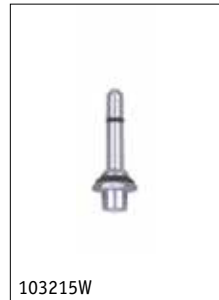

103215W



WVS13

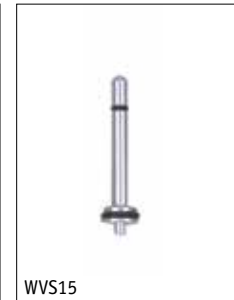

WVS15

DRY CHEMICAL VALVE STEMS. Flag. Pkg/5
(priced each).

P/N	DESCRIPTION
552144FG*	Flag Valve Stems (Old 429538AS) ♦ *WHILE QUANTITIES LAST!



552144FG

DRY CHEMICAL VALVE STEMS. Fyr-Fyter. Pkg/5
(priced each).

P/N	DESCRIPTION
FVS19*	Valve Stems Comparable to 125558F
FVS21	Valve Stems Comparable to 109438F *WHILE QUANTITIES LAST!



FVS19



FVS21

♦ Item in Valve Stem Kit (VSKIT), see page 229.

11 FIRE EXTINGUISHER PARTS



440068K



877546K



KVS46

DRY CHEMICAL VALVE STEMS. Kidde. Pkg/5

(priced each).

P/N	DESCRIPTION
440068K	Kidde Valve Stems ♦
877546K	Kidde Valve Stems ♦
KVS46*	Valve Stems
	Comparable to 843704K

*WHILE QUANTITIES LAST!



S4PA



PNV51



RCV54

DRY CHEMICAL VALVE STEMS. Pem All, Pyronauts, and RC Ind. Pkg/5 (priced each).

P/N	DESCRIPTION
S4PA*	Pem All Valve Stems
PNV51*	Valve Stems
	Comparable to 106PN
RCV54*	Valve Stems
	Comparable to LR006RC

*WHILE QUANTITIES LAST!



110427SF



161428SF

DRY CHEMICAL VALVE STEMS. Strike First. Pkg/5

(priced each).

P/N	DESCRIPTION
110427SF	Strike First Valve Stems ♦
161428SF	Strike First Valve Stems ♦



6093A



429099AS



12426B



FVS21

PRESSURIZED WATER VALVE STEMS. Amerex,

Ansul, Badger, and Fyr-Fyter. Pkg/5 (priced each).

P/N	DESCRIPTION
6093A	Amerex Valve Stems ♦
12426B	Badger Valve Stems ♦
429099AS	Ansul Valve Stems ♦
FVS21	Valve Stems
	Comparable to 109438F



6092A



6093A



ASVS4

HALON VALVE STEMS. Amerex and Ansul. Pkg/5

(priced each).

P/N	DESCRIPTION
6092A	Amerex Valve Stems ♦
6093A	Amerex Valve Stems ♦
ASVS4	Valve Stems ♦
	Comparable to 24489AS



18672B



103214W

HALON VALVE STEMS. Badger and Buckeye. Pkg/5

(priced each).

P/N	DESCRIPTION
18672B	Badger Valve Stems
103214W	Buckeye Valve Stems

♦ Item in Valve Stem Kit (VSKIT), see page 229.

HALON VALVE STEMS. Pem All. Pkg/5 (priced each).

P/N	DESCRIPTION
S4PA*	Pem All Valve Stems
	*WHILE QUANTITIES LAST!

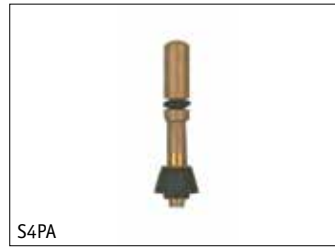

S4PA



RCVS54

HALON VALVE STEMS. RC Ind. Pkg/5 (priced each).

P/N	DESCRIPTION
RCVS54*	Valve Stems
	Comparable to LR006RC
	*WHILE QUANTITIES LAST!



14327A



13288A

HALOTRON® I VALVE STEMS. Amerex. Pkg/5 (priced each).

P/N	DESCRIPTION
14327A	Amerex Valve Stems
13288A	Amerex Valve Stems



23068B



23355B

HALOTRON® I VALVE STEMS. Badger. Pkg/5 (priced each).

P/N	DESCRIPTION
23068B	Badger Valve Stems
23355B	Badger Valve Stems
23086B	Badger Valve Stems

HALOTRON® I VALVE STEMS. Buckeye. Pkg/5 (priced each).

P/N	DESCRIPTION
103216W	Buckeye Valve Stems



103216W

Cleanguard FE-36 VALVE STEMS. Ansul. Pkg/5 (priced each).

P/N	DESCRIPTION
ASVS4	Valve Stems ♦
	Comparable to 24489AS
429099AS	Ansul Valve Stems ♦



ASVS4



429099AS

CO₂ VALVE STEMS. Amerex, Ansul, Badger, Buckeye, RS, and Superior. Pkg/5 (priced each).

P/N	DESCRIPTION
1539A	Amerex Valve Stems
418682AS	Ansul Valve Stems
5558B	Badger Valve Stems
20981B	Badger Valve Stems
900321W	Buckeye Valve Stems
418682AS	RS/Superior Valve Stems (P5970-21)



1539A



418682AS

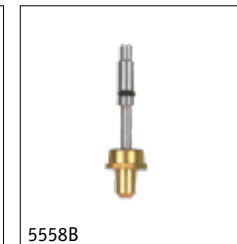

5558B

Our **VALVE STEM KIT** contains five each of our 16 best selling valve stems (see valve stems marked with an ♦). Stems come in a handy clear storage box with a full-scale illustration of each one.

P/N	DESCRIPTION
VSKIT	Valve Stem Kit
LPC16	Clear Parts Bin Box (Empty)

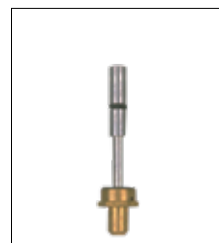

20981B



900321W



VSKIT

♦ Item in Valve Stem Kit, (VSKIT), see above.



O-RINGS

O-RINGS

UL RECOGNIZED COMPONENT VALVE STEM and GAUGE O-RINGS. Pkg/10 (priced each).

P/N	DESCRIPTION
OR4	Valve Stem Shaft O-Rings
OR5	Valve Stem Shaft & Gauge O-Rings
OR6	Valve Stem Shaft O-Rings
OR25	Valve Stem O-Rings Comparable to 70567AS, 33030G

UL RECOGNIZED COMPONENT HOSE, NOZZLE, and ELBOW O-RINGS. Pkg/10 (priced each).

P/N	DESCRIPTION
OR8	Nozzle/Hose O-Rings ♦ Comparable to 1532A, 14911B, 5857G, 64350011K
OR10	Nozzle/Hose O-Rings ♦ Comparable to 6978A, 320914K
OR18	Nozzle/Hose O-Rings Comparable to 3469AC, 701B
OR165	Elbow O-Rings Comparable to 5689A, 21101B, 900331W
OR906	Hose O-Rings Comparable to 6263AC
OR908	Hose O-Rings Comparable to 6323AC
OR910	Hose O-Rings Comparable to 6324AC

UL RECOGNIZED COMPONENT COLLAR O-RINGS

for Water and Dry Chemical Extinguishers. Pkg/10 (priced each).

P/N	DESCRIPTION
OR22	Collar O-Rings Comparable to 14913B
OR31	Collar O-Rings Comparable to 32518G
OR32	Collar O-Rings Comparable to 33806G
OR33	Collar O-Rings Comparable to 64350226K
OR35	Collar O-Rings Comparable to 320005K
OR37	Collar O-Rings ♦ Comparable to 900001W
OR43	Collar O-Rings Comparable to 56610327K
OR315	Collar O-Rings Comparable to 64350222K

UL RECOGNIZED COMPONENT COLLAR O-RINGS

for Water, Dry Chemical, Halon 1211, and FE-36 Extinguishers.

Pkg/10 (priced each).

P/N	DESCRIPTION
OR20	Collar O-Rings ♦ Comparable to 900004W, 552007FG, 11178G
OR21	Collar O-Rings ♦ Comparable to 33178G, RR008RC, 161345SF
OR26	Collar O-Rings ♦ Comparable to 53PA
OR27	Collar O-Rings ♦ Comparable to 5241A, 429537AS, 20745B, 900010W, 10513FG, 320680K
OR28	Collar O-Rings ♦ Comparable to 428327AS, L3PA
OR29	Collar O-Rings ♦ Comparable to 5240A, 56909AS, 20746B
OR30	Collar O-Rings Comparable to 64350218K
OR195	Collar O-Rings ♦ Comparable to 79122AS
OR305	Collar O-Rings Comparable to 35786G

♦ Item in O-Ring Kit (ORKIT), see page 231.



O-RINGS



O-RINGS



O-RINGS

COLLAR O-RINGS for Carbon Dioxide Extinguishers. Pkg/10 (priced each).

P/N	DESCRIPTION
OR39	Collar O-Rings ♦ Comparable to 1124A, 900329W
OR295	Collar O-Rings ♦ Comparable to 79805AS, 16464B, 320130K

GASKETS for Dry Chemical Extinguishers. Pkg/10 (priced each).

P/N	DESCRIPTION
G45	Cartridge Receiver Gaskets Comparable to 181AC
G48	Fill Cap Gaskets Comparable to 6190AC

QUAD RINGS for Dry Chemical Extinguishers. Pkg/10 (priced each).

P/N	DESCRIPTION
QR39	Fill Cap Quad Rings Comparable to 6273AS
QR40	Collar Quad Rings ♦ Comparable to 16222AS
QR41	Collar Quad Rings ♦ Comparable to 25765AS

QUAD RINGS for Halon 1211 and FE-36 Extinguishers. Pkg/10 (priced each).

P/N	DESCRIPTION
QRH43	Collar Quad Rings Comparable to 21882AS

Our **O-RING KIT** comes in a handy clear storage box (16 compartment) with a full-scale illustration of each one and includes O-rings marked with an (♦) as well as the **259535K** and **340035K**.

P/N	DESCRIPTION
ORKIT	O-Ring Kit

V-711 SILICONE GREASE is stiff, tacky, and dielectric.

P/N	DESCRIPTION
SLUBE	Silicone Grease, 4.32 oz Tube

Parker O-LUBE is an outstanding general-purpose grease for O-rings and seals. Protects O-rings against abrasion in DC units.

P/N	DESCRIPTION
OLUBE2	O-Ring Lubricant, 2 oz Tube

♦ Item in O-Ring Kit (ORKIT), see above.

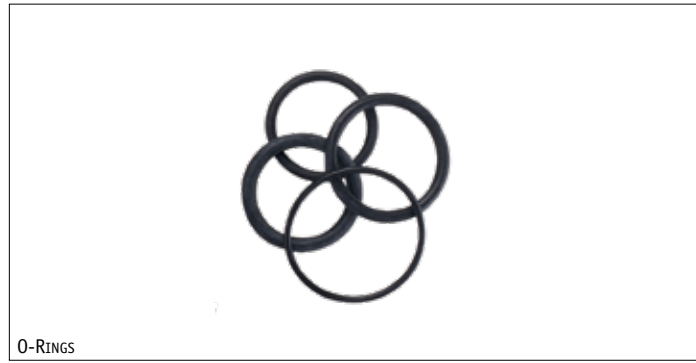

O-RINGS

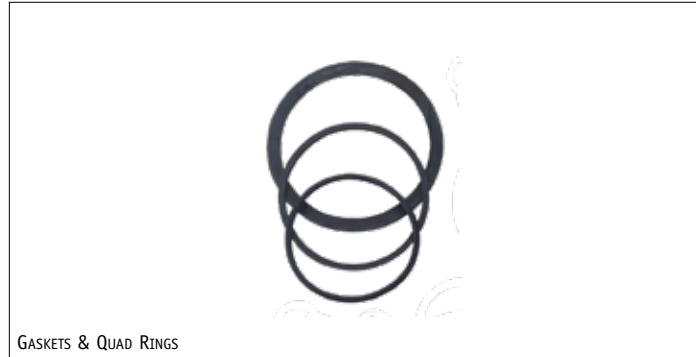

GASKETS & QUAD RINGS



ORKIT



SLUBE



OLUBE2



RIVETS

RIVETS. Pkg/50 (priced per pack).

P/N	DESCRIPTION
RV5	Handle Rivets Comparable to 1564A, 900052W
RV7	Handle Rivets Comparable to 1563A
RV14	Lever Rivets Comparable to 13145G, 32057G
RV30	Handle Rivets Comparable to 6561B, 16517B
RV33	Handle/Lever Rivets Comparable to 9992100PP
RV38	Handle/Lever Rivets Comparable to 900042W

RIVETS. Pkg/50 (priced per pack).

P/N	DESCRIPTION
RV44	Handle Rivets Comparable to 25719AS
RV46	Handle Rivets Comparable to RV001RC, 32075G
RV47	Handle Rivets Comparable to 25720AS
RV48	Lever Rivets Comparable to RV002RC, RV003RC, 32061G
RV49	Handle Rivets Comparable to 32058G
RV53	Handle/Lever Rivets Comparable to 33699G, 33027G
RV59	Handle Rivets Comparable to 123PN

RIVETS. Pkg/50 (priced per pack).

P/N	DESCRIPTION
RV63	Handle Rivets Comparable to 34076G
RV64	Handle Rivets Comparable to 35774G
RV67	Handle Rivets Comparable to 32062G
RV71	Handle Rivets Comparable to 34991G
RV78	Lever Rivets Comparable to RV004RC, 17050AS
RV80	Handle/Lever Rivets Comparable to 162803SF
RV81	Handle Rivets Comparable to 206363K, 50013F

Our **RIVET KIT** contains 50 each of the rivets listed above (for a total of 1000 rivets) that come in a handy clear storage box with full-scale illustrations.

P/N	DESCRIPTION
RKIT	Rivet Kit

SMALL PARTS STORAGE

Designed to hang, stack, or nest, these **PLASTIC STORAGE BINS** are made of industrial-grade polymer and come with hopper front openings for easy access. They are also injection molded to help resist weak acids and alkalis while remaining water, rust, and corrosion proof. Blue.

P/N	DESCRIPTION	L X H X D
→ 30210TF	Plastic Bin	5 ³ / ₈ " x 3" x 4 ¹ / ₈ "
→ 30220TF	Plastic Bin	7 ³ / ₈ " x 3" x 4 ¹ / ₈ "
→ 30230TF	Plastic Bin	10 ⁷ / ₈ " x 5" x 5 ¹ / ₂ "
→ 30235TF	Plastic Bin	10 ⁷ / ₈ " x 5" x 11"
→ 30240TF	Plastic Bin	14 ³ / ₄ " x 7" x 8 ¹ / ₄ "
→ 30250TF	Plastic Bin	14 ³ / ₄ " x 7" x 16 ¹ / ₂ "

Made of corrosion-proof, industrial-grade polymers, these hang or stack, **STANDARD STORAGE BINS** have reinforced sides and extra-wide ledges to help prevent spills or spreading when stacked. They also come standard with anti-slide stops, curved-bottom hopper fronts, and large label areas. Acid and alkali resistant as well as water and rust proof. Colors available: Red (R), Yellow (Y), Green (G), Blue (B), Stone (S), and Clear (CL).

P/N	DESCRIPTION	L X H X D
→ 30210_AM	AkroBin Standard Bin	5 ³ / ₈ " x 3" x 4 ¹ / ₈ "
→ 30220_AM	AkroBin Standard Bin	7 ³ / ₈ " x 3" x 4 ¹ / ₈ "
→ 30224_AM	AkroBin Standard Bin	10 ⁷ / ₈ " x 4" x 4 ¹ / ₈ "
→ 30230_AM	AkroBin Standard Bin	10 ⁷ / ₈ " x 5" x 5 ¹ / ₂ "
→ 30240_AM	AkroBin Standard Bin	14 ³ / ₄ " x 7" x 8 ¹ / ₄ "
→ 30250_AM	AkroBin Standard Bin	14 ³ / ₄ " x 7" x 16 ¹ / ₂ "
→ 30260_AM	AkroBin Standard Bin	18" x 10" x 11"

More AKROBINS Available — Call for Pricing.

Our five-drawer **PARTS BIN RACK** holds our **CLEAR PARTS BIN BOXES** (sold separately).

P/N	DESCRIPTION
PBR1	Parts Bin Rack (Empty)
LPC16	Clear Parts Bin Box, 16 Compartments
LPC24	Clear Parts Bin Box, 24 Compartments

This **PLASTIC STORAGE CASE** has 15 compartments and a clear lid for easy viewing. Measures 11"L x 2³/₈"H x 7"W.

P/N	DESCRIPTION
05805AM	Plastic Storage Case

The **PORTABLE STORAGE ORGANIZER** comes with 46 compartments that use countersunk partitions (with dovetail ends) to stop part migration. A built-in carry handle adds easy transport. Measures 15"L x 3¹/₄"H x 11⁵/₆"W. Blue/Clear.

P/N	DESCRIPTION
06115AM	Portable Storage Organizer



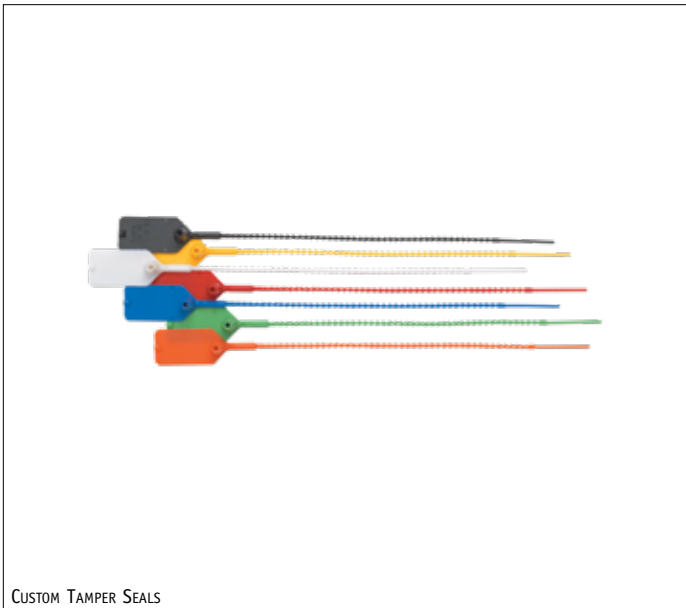

CUSTOM TAMPER SEALS

CUSTOM TAMPER SEALS

Brooks' CUSTOM TAMPER SEALS feature $\frac{13}{16}$ " x $\frac{19}{32}$ " medium and $1\frac{3}{8}$ " x $\frac{19}{32}$ " large print areas. These matted seals are available in seven colors: Black, Yellow, Red, Blue, Green, White, and Orange. There are five imprint colors: Dark Blue, Red, Yellow, Black, and White. Bag/1000 (10,000 minimum).

NOTE: Please select both colors (seal/print). **A signed proof is required to process all orders!** The Custom Die Charge is waived for exact re-orders only.

P/N	DESCRIPTION
SSPFLAG	9" Custom Tamper Seals, Medium
SSPLGFG	10" Custom Tamper Seals, Large
SSPFLAGDIE	Custom Die Charge (Initial Set-Up Fee)

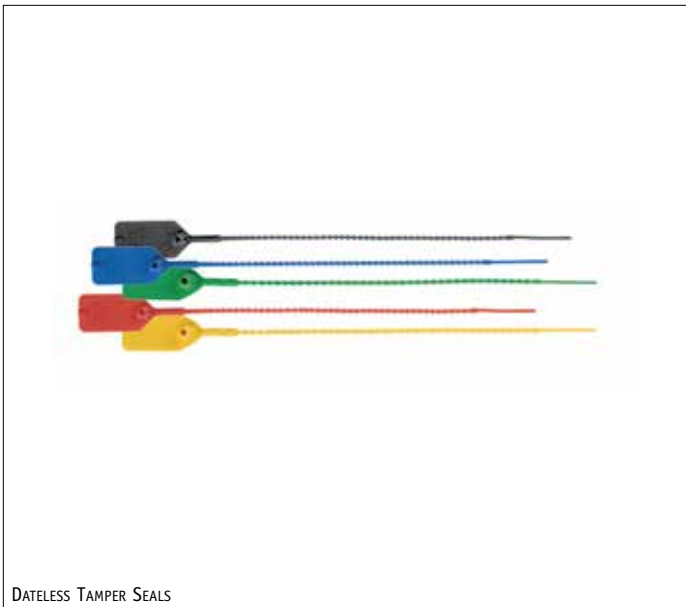

DATELESS TAMPER SEALS

NON-CUSTOM TAMPER SEALS

Brooks' DATELESS TAMPER SEALS are UL recognized components for fire extinguishers and are available in five colors. Measures 9". Bag/500.

P/N	DESCRIPTION
CNDSY	Dateless Tamper Seals, Yellow
CNDSR	Dateless Tamper Seals, Red
CNDSBL	Dateless Tamper Seals, Blue
CNDSG	Dateless Tamper Seals, Green
CNDSBK	Dateless Tamper Seals, Black

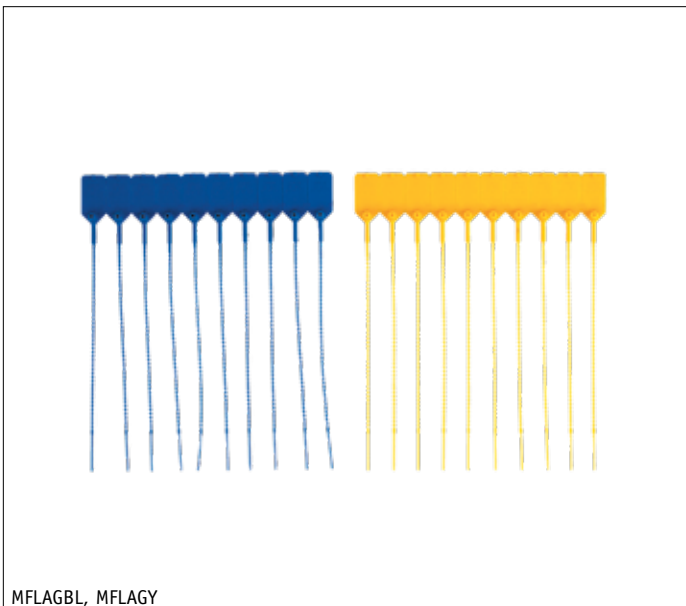

MFLAGBL, MFLAGY

Brooks' DATELESS MEDIUM MATTED TAMPER

SEALS are UL recognized components for fire extinguishers and come in seven colors. Measures 9". Bag/500 (50 matted sheets of 10 each).

P/N	DESCRIPTION
MFLAGY	Dateless Medium Tamper Seals, Yellow
MFLAGBK	Dateless Medium Tamper Seals, Black
MFLAGR	Dateless Medium Tamper Seals, Red
MFLAGBL	Dateless Medium Tamper Seals, Blue
MFLAGG	Dateless Medium Tamper Seals, Green
MFLAGW	Dateless Medium Tamper Seals, White
MFLAGO	Dateless Medium Tamper Seal, Orange

LARGE DATE TAMPER SEALS are available in many color combinations. Dated with the current year (shows seal has been replaced during annual maintenance, according to NFPA 10). Measures 9". Bag/500.

P/N	DESCRIPTION
FTSRW	Large Date Tamper Seal, Red w/ White Imprint
FTSYBK	Large Date Tamper Seal, Yellow w/ Black Imprint
FTSBW	Large Date Tamper Seal, Blue w/ White Imprint
FTSBKGD	Large Date Tamper Seal, Black w/ Gold Imprint
FTSWB	Large Date Tamper Seal, White w/ Blue Imprint
FTSGW	Large Date Tamper Seal, Green w/ White Imprint
FTSWR	Large Date Tamper Seal, White w/ Red Imprint
FTSOBK	Large Date Tamper Seal, Orange w/ Black Imprint

More LARGE DATE TAMPER SEALS Available. Call for Pricing.

Brooks' DATED MEDIUM TAMPER SEALS are UL recognized components for fire extinguishers. Available in seven colors, they come dated (current year) to show seals have been replaced during annual maintenance (in accordance with NFPA 10). Measures 9". Bag/500.

NOTE: Add two-digit year to part number, ie. **FLAGY18**.

P/N	DESCRIPTION
FLAGY	Dated Medium Tamper Seals, Yellow
FLAGR	Dated Medium Tamper Seals, Red
FLAGBL	Dated Medium Tamper Seals, Blue
FLAGG	Dated Medium Tamper Seals, Green
FLAGW	Dated Medium Tamper Seals, White
FLAGO	Dated Medium Tamper Seals, Orange
FLAGBK	Dated Medium Tamper Seals, Black

PULL-TITE DATELESS TAMPER SEALS are UL recognized components for fire extinguishers and come in seven colors. Measures 9". Bag/500.

P/N	DESCRIPTION
EJBY	Pull-Tite Dateless Tamper Seals, Yellow
EJBBK	Pull-Tite Dateless Tamper Seals, Black
EJBBL	Pull-Tite Dateless Tamper Seals, Blue
EJBG	Pull-Tite Dateless Tamper Seals, Green
EJBO	Pull-Tite Dateless Tamper Seals, Orange
EJBR	Pull-Tite Dateless Tamper Seals, Red
EJBW	Pull-Tite Dateless Tamper Seals, White

Dennison Secure-A-Seal tamper-evident POLYPROPYLENE SEALS. Yellow. Pkg/2000.

P/N	DESCRIPTION
SST	8" Polypropylene Seals

Multi-purpose **METAL WIRE SEALS.** Pkg/100.

P/N	DESCRIPTION
CS10	10" Copper Wire w/ 1/4" Lead Seals
SS10	10" Galvanized Steel Wire w/ 1/4" Lead Seals
SS16	16" Galvanized Steel Wire w/ 7/16" Lead Seals

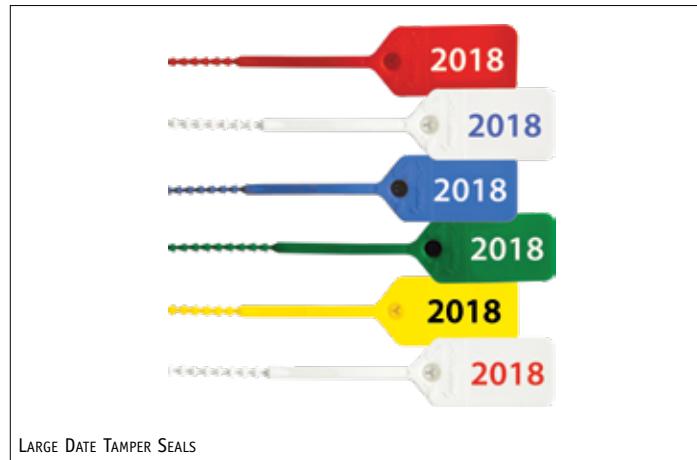

LARGE DATE TAMPER SEALS

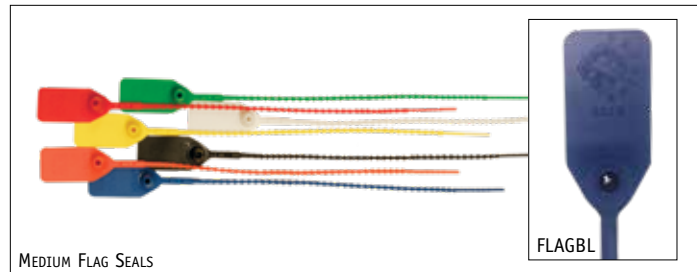

MEDIUM FLAG SEALS

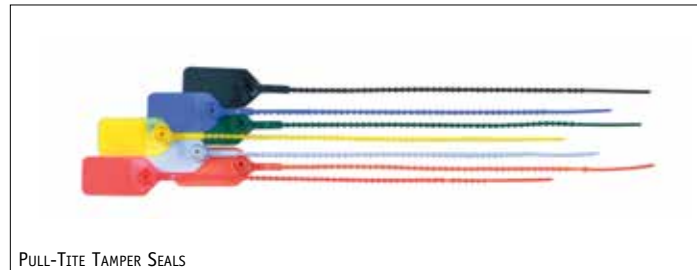

PULL-TITE TAMPER SEALS



CS10

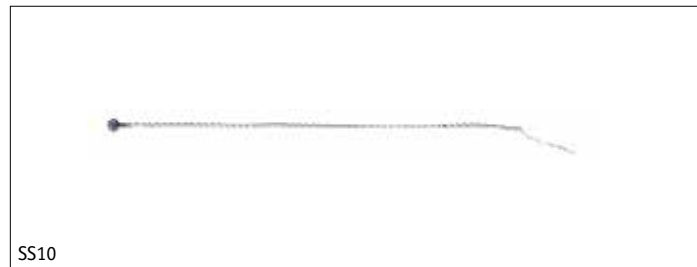

SS10

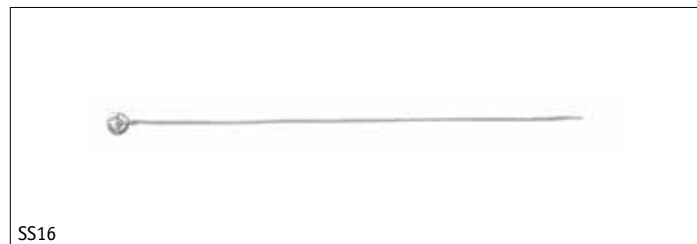

SS16

11 FIRE EXTINGUISHER PARTS

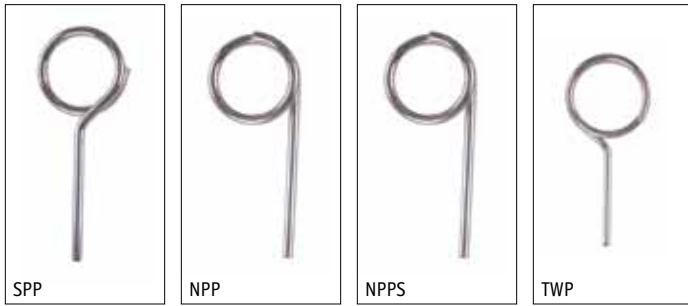

PULL PINS

PULL PINS. Pkg/100 (priced per pack).

P/N	DESCRIPTION
SPP	Single-Point Pull Pins, Steel
NPP	New-Type Pull Pins, Steel

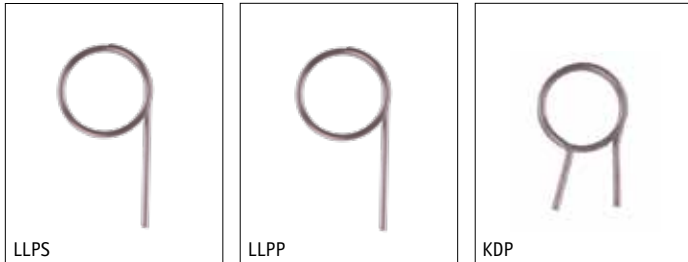

PULL PINS. Priced each.

P/N	DESCRIPTION
NPPS	New-Type Pull Pin, Stainless Steel
TWP	Thin Wire Pull Pin, Steel

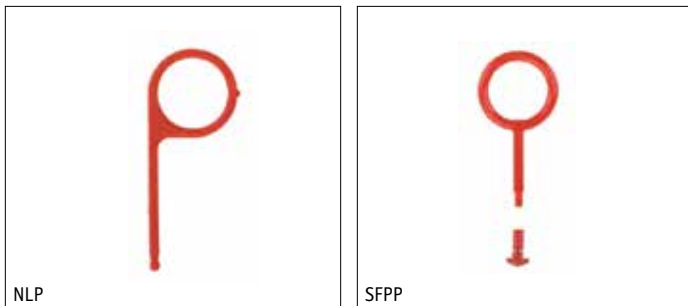

PULL PINS. Priced each.

P/N	DESCRIPTION
LLPS	Large Loop Pull Pin, Stainless Steel
LLPP	Large Loop Pull Pin, Steel
KDP	Kidde Type Double Point Pull Pin, Stainless Steel
NLP*	Red Pull Pin, Plastic
SFPP*	Strike First Type Red Pull Pin Assembly, Plastic

*NON-MAGNETIC

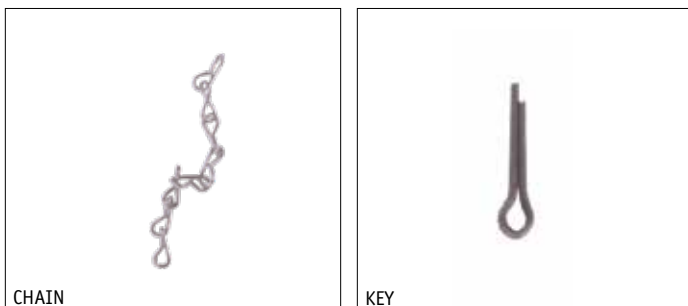

PULL PIN ACCESSORIES. Priced each.

P/N	DESCRIPTION
CHAIN	4" Single Jacket Galvanized Chain
KEY	Cotter Key
532A*	Nylon Chain
	For Amerex Pull Pin

*NON-MAGNETIC

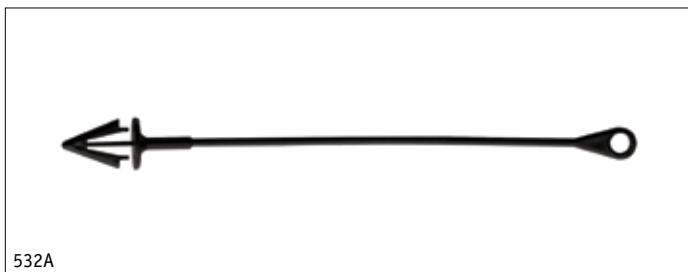

CARTRIDGE BUSHINGS AND SHIPPING CAPS

FILLING BONNETS



P/N	DESCRIPTION
B2081	Filling Bonnet
	Use with Ansul & General D/C CO ₂ Cartridges
B2082	Filling Bonnet
	Use with System Cartridges
OR26	Bonnet O-Rings
B209	Bushing Tool
	For B2081 & B2082 Bonnets
OR165	B209 Stem O-Rings

“A” and “AA” BUSHINGS should be tightened to 40 ft-lb torque at room temperature.
NOTE: SEE WARNING below.

P/N	DESCRIPTION
A	Bushing For Ansul Portable D/C Extinguisher Cartridges
AA	Bushing For Ansul D/C Systems & Nitrogen Cartridges



“E” BUSHINGS should be tightened to 25 ft-lb torque at room temperature.
NOTE: SEE WARNING below.

P/N	DESCRIPTION
E	Bushing For General Outside Mounted D/C Extinguisher Cartridges
TW	18" Torque Wrench w/ 1/2" Drive, 10–150 ft-lb



Cartridge **SHIPPING CAPS.**

P/N	DESCRIPTION
LHSC	LH Thread Cartridge Shipping Cap
RHSC	RH Thread Cartridge Shipping Cap

WARNING: The above parts and accessories are only a partial list of items and equipment needed to safely refill carbon dioxide and nitrogen cartridges. These parts and accessories should be purchased and used **only** by personnel who are thoroughly familiar with, and understand, the standards published in the Compressed Gas Association pamphlets G-6 and S-1.1, Code of Federal Regulations title 49, parts 100 thru 199, and who have received “hands-on” training under the direct supervision of someone experienced in cartridge refilling. If you lack the knowledge, training, or experience described above, **do not** attempt to refill either carbon dioxide or nitrogen cartridges. Instead, we recommend that you purchase either new cartridges or have them refilled by an established service facility. **Failure to adhere to the above instructions could result in serious injury or death.**

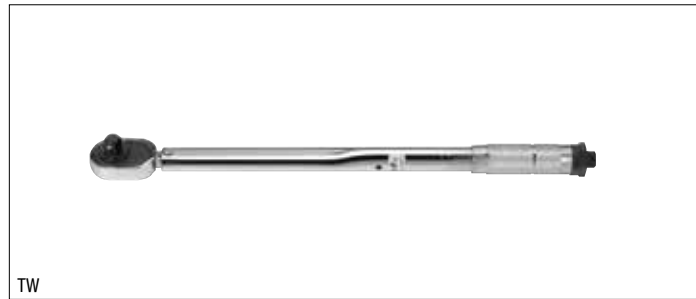

CO₂ FIRE EXTINGUISHER VALVES

CO₂ FIRE EXTINGUISHER VALVES for 1/2"-neck steel cylinders.

P/N	DESCRIPTION
BHV50	FireTech CO ₂ Valve
PSH2	RS CO ₂ Valve
SW50	Swivel Discharge Assembly For PSH2 Valves & BHV50
DCT	1/8" Brass Discharge Tube For BECO PSH Valves

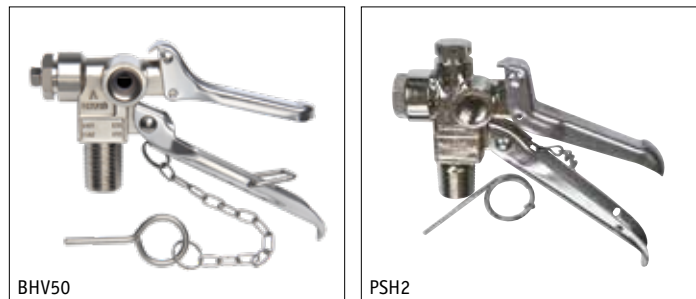

11 FIRE EXTINGUISHER PARTS



BHV100



PSH1

CO₂ FIRE EXTINGUISHER VALVES for 1"-neck steel cylinders. See page 293 for replacement parts.

P/N	DESCRIPTION
BHV100	FireTech CO ₂ Valve w/ Latch
PSH1	RS CO ₂ Valve w/ Latch
EL250	1/4" Elbow w/ Diffuser
EL375	3/8" Elbow w/ Diffuser



3090A



EL10, EL5

CO₂ FIRE EXTINGUISHER VALVES for 1 1/8"-neck aluminum cylinders.

P/N	DESCRIPTION
3090A	CO ₂ Valve
EL10	3/8" Elbow w/ Diffuser For 10-20 lb 3090A Valves
EL5	Elbow For 5 lb 3090A Valves
DCT	1/8" Brass Discharge Tube For 3090A w/ EL5



EL250



BA100

WHEELED UNIT VALVES for 50-100 lb CO₂ units.

P/N	DESCRIPTION
BA100	1" Handwheel Valve
BA100STEMD	Valve Stem For BA100
RS5	Disc, Washer, & Nut Assembly For BA100



EL375

WHEELED UNIT VALVES

P/N	DESCRIPTION
CEV	3/4" Nitrogen Valve w/ 3000 psi Gauge For Dry Chemical Wheeled Units
→ CEV4	3/4" Nitrogen Valve w/ 4000 psi Gauge For Dry Chemical Wheeled Units
CEVDW	Safety Disc & Washer For CEV & CEVQR
CEVSN	Safety Nut For CEV & CEVQR
→ CEVSN4	Safety Nut For CEV4 & CEVQR4
CEVQR	3/4" Quick-Release Nitrogen Valve w/ 3000 psi Gauge For Dry Chemical Wheeled Units
CEVQR4	3/4" Quick-Release Nitrogen Valve w/ 4000 psi Gauge
CEVDW4	Safety Disc & Washer For CEVQR4
CEVSTEM	Lower Seat Stem For CEV
CEVSPINDLE	Upper Spindle For CEV
G3000	3000 psi Replacement Gauge For CEV, CEVQR, & 12467A



CEV



CEVQR

QUICK-RELEASE VALVES

P/N	DESCRIPTION
9895A	3/4" Quick-Release Valve For 50-100 lb CO ₂ Cylinders
12467A	3/4" T-Handle Quick-Release Nitrogen Valve w/ Gauge
4000A	Safety Disc, Washer, & Nut Assembly For 9895A

Brass **COMMERCIAL CO₂ VALVES** are for aluminum and steel cylinders and come threaded to accept siphon tubes (except **CV50**) when used with **COMB** adapters. See page 293 for size information.

P/N	DESCRIPTION
CV50	CO ₂ Valve For 1/2" Neck Steel Cylinders
CV75	CO ₂ Valve For 3/4" Neck Steel Cylinders
CV100	CO ₂ Valve For 1" Neck Steel Cylinders
CV100A	CO ₂ Valve For 1 1/8" Straight-Thread Aluminum Cylinders
OR39	O-Ring For CV100A Valves

Brass **COMMERCIAL NITROGEN VALVES.**

P/N	DESCRIPTION
NV75	3/4" Nitrogen Valve w/ CGA 580 Outlet
NV100	1" Nitrogen Valve w/ CGA 580 Outlet
PC1	Plastic Thread Protector For 1/2" Outlet Valves
PC2	SCBA Thread Saver For Scott, MSA, & Survivair w/ 18" Cord
HWG	Handwheel Grip For Valves

CO₂ SIPHON TUBES

SIPHON TUBES for extinguisher and commercial CO₂ valves.
NOTE: Always verify siphon tube is the correct length. More specifically, the siphon tube bottom should rest approximately 1/4" from the inside bottom of the cylinder (with the valve in place).
 If cutting is necessary, make it at 45°. This prevents the tube from sealing against the cylinder bottom.

P/N	DESCRIPTION
2ST	2.5 & 5 lb CO ₂ Siphon Tube
10ST	10 lb CO ₂ Siphon Tube
15ST	15 & 20 lb CO ₂ Siphon Tube
COMB	Siphon Tube Adapter Fits 2ST, 10ST, & 15ST
50ST	50 & 75 lb CO ₂ Siphon Tube Fits BA100 & 24128G (Only)
50BIST	Black Iron Siphon Tube, 53 1/2" x 1/4", NPT Fits CV75 & CV100 Valves

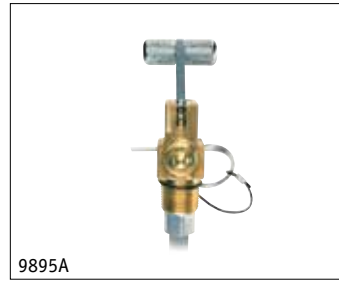

9895A



12467A



CV50



CV100A



NV75



NV100

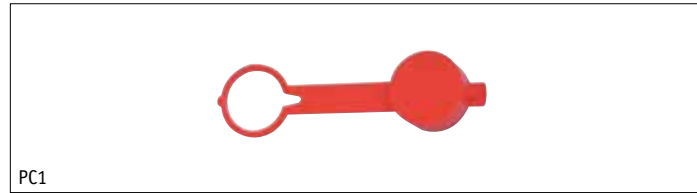

PC1



PC2



HWG



10ST



15ST



50ST



COMB

CO₂ SAFETY DISCS & WASHERS

CO₂ SAFETY DISCS AND WASHERS

CO₂ SAFETY DISCS and **WASHERS** are for CO₂ fire extinguisher valves only. See pages 294 and 295 for **Sherwood** and **Superior** commercial valve safety disc assemblies.

P/N	DESCRIPTION
4000A	Amerex Disc, Washer, & Nut Assembly – 3090A & 9895A Valves 250 in-lb (21 ft-lb)
429515AS	Ansul Disc, Washer, & Nut Assembly 35 ft-lb
RS5	Ansul Disc, Washer, & Nut Assembly – Canadian Valves 35 ft-lb
24643B	Badger Disc, Washer, & Nut Assembly 25-30 ft-lb
200081W	Buckeye Disc, Washer, & Nut Assembly 32 ft-lb
50115F	Fyr-Fyter Safety Disc 20 ft-lb
50116F	Fyr-Fyter Copper Washer
24643B	Kidde Disc, Washer, & Nut Assembly 25-30 ft-lb
260299K	Kidde Safety Disc – Aluminum Valves 250-275 in-lb (21-23 ft-lb)
258443K	Kidde Aluminum Washer
29450K	Kidde Copper Washer
RS5	RS Valve Disc, Washer, & Nut Assembly - PSH1, PSH2 & BA100 Valves 27 ft-lb
C16SV	Superior Safety Disc (Small Style for Extinguisher Valve) 72-84 in-lb (6-7 ft-lb)
C15SV	Superior Copper Washer (Small Style for Extinguisher Valve)
16ASV	Superior Safety Disc (Large Style for Military Valve) 35 ft-lb
15SV	Superior Copper Washer (Large Style for Military Valve)



B114, STB114



B115



RDH10, RDH15

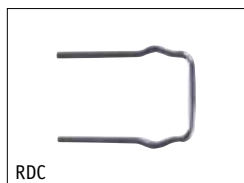

RDC



B128

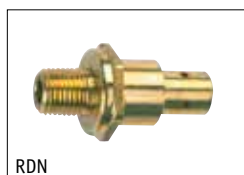

RDN



B222

See page 205 for Torque Wrenches.

CO₂ HORNS, NIPPLES, AND HANDLES

CO₂ HORNS, NIPPLES, HANDLES, and CLIPS.

NOTE: There are several different 5 lb horn and discharge tube designs. To ensure correct replacement parts, carefully check the old horn and tube. Some discharge tubes have a long diffuser tip and will not work with certain horns. Test for CO₂ flow through discharge tube and horn assembly to be sure.

P/N	DESCRIPTION
B114	5 lb CO ₂ Horn w/ Diffuser For Discharge Tubes w/o Diffuser
STB114	5 lb CO ₂ Horn For Discharge Tubes w/ Built-In Diffuser
B11510	Conical Horn w/ Brass Diffuser For 10 lb CO ₂ Extinguishers
B115	Conical Horn w/ Brass Diffuser For 15 & 20 lb CO ₂ Extinguishers
RDH10	Rapid Discharge Horn & Handle For 10 lb CO ₂ Extinguishers
RDH15	Rapid Discharge Horn & Handle For 15 & 20 lb CO ₂ Extinguishers
RDC	Diffuser Clip For RDH CO ₂ Horns
RDN	Diffuser For RDH CO ₂ Horns
B128	Rubber Handle For All Conical Horns
B222	1/4" x 6" Galvanized Steel Nipple For All Conical Horns

This safety **HORN HOLDER** keeps the horn in the down position, against the extinguisher, preventing water from entering the hose and horn. Use the **UHS35** strap to install.

P/N	DESCRIPTION
SHH	Safety CO ₂ Horn Holder
UHS35	Universal Hose Strap



SHH w/ UHS35 In Use

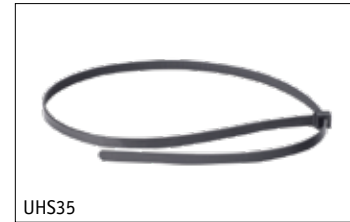

UHS35



SHH

WHEELED CO₂ UNIT HORN ASSEMBLY

NOTE: The nipple/handle attaches to the 3/8" female side of valve assembly. Horn attaches to other end of nipple, while hose attaches to 1/2" male side of valve.

P/N	DESCRIPTION
CSV	Valve Assembly For 50 & 75 lb CO ₂
CSH	CO ₂ Horn w/ Diffuser
CSN	3/8" x 18" Galvanized Steel Nipple
CSR	Rubber Handle For CSN Nipples



CSV, CSH, CSN, CSR

CO₂ HOSE ASSEMBLIES

CO₂ FIRE EXTINGUISHER HOSE assemblies meet or exceed UL Standard 154 and feature perforated rubber-covered wire-braided hose with heavy-duty brass couplings. They are rated at 10,000 lb bursting pressure and 2500 lb working pressure.

P/N	DESCRIPTION
32A	32" Hose, 1/4" F x 1/4" F For 10-20 lb CO ₂ Extinguishers
32B	32" Hose, 1/4" F x 3/8" F For 10-20 lb CO ₂ Extinguishers
36A	36" Hose, 1/4" F x 1/4" F For 10-20 lb CO ₂ Extinguishers
36B	36" Hose, 1/4" F x 3/8" F For 10-20 lb CO ₂ Extinguishers



32A, 36A

CO₂ WHEELED UNIT HOSE assemblies meet or exceed UL Standard 154 and come with the same features as our **CO₂ Fire Extinguisher Hose** assemblies above.

WARNING: Leaving hose charged for long periods may result in jacket blistering.

P/N	DESCRIPTION
15FF	15' CO ₂ Hose, 1/2" F x 1/2" F For 50 lb & Larger Wheeled & Stationary Units
40FF	40' CO ₂ Hose, 1/2" F x 1/2" F For 50 lb & Larger Wheeled & Stationary Units
CPLF	Coupling, 1/2" F x 1/2" F To Change Hose End from Male to Female
CPLM	Adapter, 1/2" M x 1/2" M To Change Hose End from Female to Male



15FF



CPLF



CPLM

11 FIRE EXTINGUISHER PARTS

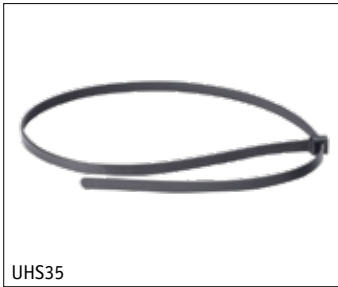

UHS35



UHC

REPLACEMENT BANDS AND STRAPS

UNIVERSAL HOSE STRAPS and CLIPS.

P/N	DESCRIPTION
UHC	Universal Hose Clip
UHS35	Universal Hose Strap



UHC w/ UHS35 In Use



LCC38 In Use

1-PIECE HOSE STRAP and **CLIP** assemblies fit cylinders up to 7" Dia.

P/N	DESCRIPTION
LCC12	1-Piece Hose Strap & Clip Fits 1/2" Dia Hose
LCC38	1-Piece Hose Strap & Clip Fits 3/8" Dia Hose



AX20570



AX20571

CO₂ REPLACEMENT STRAPS and **CLIPS** for **Amerex®** 10–20 lb cylinders.

P/N	DESCRIPTION
AX20570	Amerex Strap & Clip For AX330 & AX331
AX20571	Amerex Strap & Clip For AX332

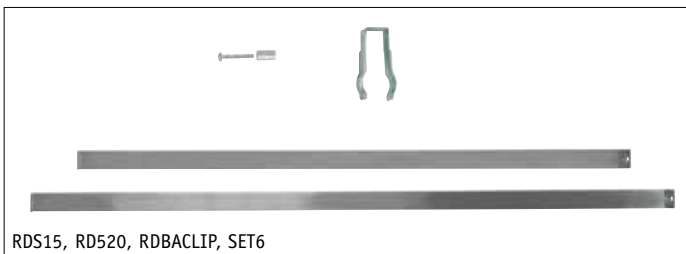

RDS15, RD520, RDBACLIP, SET6

CO₂ REPLACEMENT STRAPS for 10–20 lb cylinders.

P/N	DESCRIPTION
RDS15	Strap For Rapid Discharge Style Horns, 10–15 lb
RDS20	Strap For Rapid Discharge Style Horns, 20 lb
RDBACLIP	Clip For Rapid Discharge Style Horns
SET6	Screw & Spacer For RDS15 & RDS20



SET6 w/ RDBACLIP & RDS15 In Use

RDBACLIP

CO₂ REPLACEMENT BANDS for units with rapid discharge horns.

P/N	DESCRIPTION
RDBA	Aluminum Rapid Discharge Horn Band
SET2	Hardware – Spacer, Nut, & Screw For RDBA Bands
RDBB	Brass Rapid Discharge Horn Band
SET4	Hardware – Spacer, Nut, & Screw For RDBB Bands

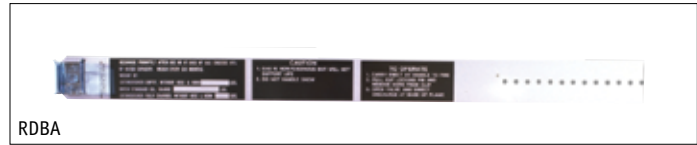

CO₂ REPLACEMENT BANDS for units with conical discharge horns.

P/N	DESCRIPTION
UBA	Aluminum Conical Discharge Horn Band
SET1	Hardware – Bar, Nut, & Screw For UBA Bands
UBB	Brass Conical Discharge Horn Band
SET3	Hardware – Bar, Nut, & Screw For UBB Bands

Reduce valve damage and make transporting cylinders easier with these **CARRYING HANDLES** and **ADAPTERS**. They provide protection for virtually all CO₂ cylinders. Adapters fit steel cylinders with neck diameters of 1⁵/₈"–1⁷/₈".

P/N	DESCRIPTION
CCH1	Luxfer Carry Handle w/ Ring, 2 ³ / ₈ " Neck
CCH2	Kidde Carry Handle w/ Ring, 2 ³ / ₁₆ " Neck
CCH3	Catalina Carry Handle w/ Ring, 2 ³ / ₈ " Neck
RING1	CCH1 Replacement Snap Ring
RING2	CCH2 Replacement Snap Ring
RING3	CCH3 Replacement Snap Ring
LHA	CCH1 Carry Handle Adapter For Steel Cylinders



BEVERAGE CYLINDER EQUIPMENT

BEVERAGE REGULATORS are for CO₂ beverage cylinders only.

NOTE: Not to be used on vacuum filling systems for extinguishers.

P/N	DESCRIPTION
BEV3	100 psi CO ₂ Beverage Regulator
100G	100 psi Replacement Gauge For BEV3
BEV4	1800/160 psi CO ₂ Beverage Regulator
160G	160 psi Replacement Gauge For BEV4
BEV5	1800/60 psi CO ₂ Beverage Regulator
60G	60 psi Replacement Gauge For BEV5
2000G	0–2000 psi Replacement Gauge w/ Right-Hand Threads
L2000G	0–2000 psi Left-Hand Thread Gauge Fits Cornelius & Watts Fluidair (BEV4)



In Use photos may show items not included or available separately.

11 FIRE EXTINGUISHER PARTS



WALL HANGERS

WALL HANGERS

P/N	DESCRIPTION
WH2	Universal Hanger For 2.5 gal Water, 10 lb D/C, & 13 lb Halon
WH5	Universal Hanger For 5 lb CO ₂ , 6-10 lb D/C, & 9 lb Halon
WH15	Universal Hanger For 10-15 lb CO ₂ & 11-15.5 lb Halotron I
WH20	Universal Hanger For 20 lb CO ₂ , 20 lb D/C, 17 lb Halon, & Class D



The **HANGER LOOP KIT** replaces broken loops on the back of stainless steel cylinders. Use it with a **WH2** wall hanger.

P/N	DESCRIPTION
HLK	Hanger Loop Kit

WALL HANGERS. Amerex.



P/N	DESCRIPTION
4834A	Amerex Hanger For 1.25 & 2.5 lb Halon & 2.5 lb D/C
1521A	Amerex Hanger For 5 lb D/C Extinguishers (Thru 2007)
16591A	Amerex Hanger For 5 lb D/C Extinguishers (2008 & Later)
5525A	Amerex Hanger For 6-13 lb Extinguishers

WALL HANGERS. Ansul.



P/N	DESCRIPTION
ACWH1	Ansul Compatible Hanger For 10-30 lb Cartridge Extinguishers
ASWH2	Ansul Compatible Hanger For 4.5-9 lb Sentry "SY Model" Extinguishers
ASWH3	Ansul Compatible Hanger For 10-14 lb Sentry "SY Model" Extinguishers
ASWH4	Ansul Compatible Hanger For 17-20 lb Sentry "SY Model" Extinguishers
A430056	Ansul Hanger For 2.5 gal Water & 6 L Wet Chem

WALL HANGERS. Kidde.



P/N	DESCRIPTION
202208K	Kidde Hanger For 4 lb CO ₂ Extinguishers
293263K	Kidde Hanger For 6 lb D/C Extinguishers
1141K	Kidde Hanger For Pro-Line Extinguishers
340357K	Kidde Hanger For 2.6-2.75 lb D/C Extinguishers
340358K	Kidde Hanger For 4-6 lb D/C Extinguishers
340791K	Kidde Hanger For 10 lb D/C Extinguishers
14260K	Kidde Hanger For 20 lb D/C Extinguishers

WALL HANGERS. Pem All and RC Ind.



P/N	DESCRIPTION
WB1PA*	Pem All Hanger For 5-10 lb Small Valve Extinguishers
WB2PA*	Pem All Hanger For 10-20 lb Large Valve Extinguishers
BT029RC	RC Ind. Hanger For 2.5-10 lb Extinguishers

*WHILE QUANTITIES LAST!

No Drilling Required!

Dual mounting, this **"I" BEAM ADAPTER** facilitates hanging portable extinguishers on "I" beams.

P/N	DESCRIPTION
IBA1	"I" Beam Adapter (Only)
IBA2	Screws, Pkg/100

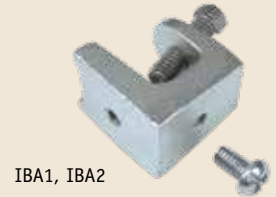

VEHICLE, SPRING CLIP, AND HEAVY-DUTY BRACKETS

VEHICLE BRACKETS. Amerex.

P/N	DESCRIPTION
817A	Amerex Bracket For 2.5 lb Extinguishers
817SA	Amerex Bracket For 2.5 lb Extinguishers w/ Double Strap
818A	Amerex Bracket For 5 lb Extinguishers
818SA	Amerex Bracket For 5 lb Extinguishers w/ Double Strap
821A	Amerex Bracket For 5 lb Extinguishers
808A	Amerex Bracket For 6 lb Extinguishers
846A	Amerex Bracket For 10 lb Extinguishers
861HA	Amerex Bracket For 5 lb Extinguishers
860A	Amerex Bracket For 3"-4 1/4" Dia Shells w/ Cord
862A	Amerex Bracket For 5"-7" Dia Shells w/ Cord
864A	Amerex Bracket For 7"-8" Dia Shells w/ Cord
7166A	Replacement Cord For 860A & 862A
7802A	Replacement Cord For 864A
RG	Heavy-Duty Rubber Grommet



817A



821A



846A



861HA

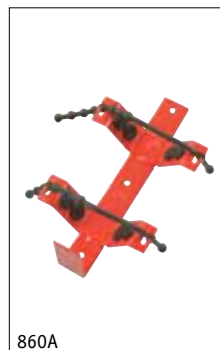

860A



862A



864A

VEHICLE BRACKETS. Ansul.

P/N	DESCRIPTION
24610AS	Ansul Sentry Bracket For 2.5 & 2.75 lb Extinguishers
415824AS	Ansul Sentry Bracket For 5 lb Extinguishers (Current Models)
429146AS	Ansul Sentry Bracket For 5 lb Extinguishers ("SY" Models, Except SY-0515)
79758AC	Ansul Bracket For 5 lb Cartridge-Operated Extinguishers

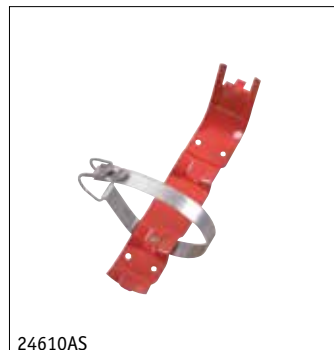

24610AS



79758AC

In Use photos may show items not included or available separately. Ansul® and Sentry® are registered marks of Tyco Fire Products LP.

11 FIRE EXTINGUISHER PARTS



MB250



700270W In Use

VEHICLE BRACKETS. Badger and Buckeye.

P/N	DESCRIPTION
MB250	Badger Bracket For 2.5 & 2.75 lb Extinguishers
MB5	Badger Bracket For 5 lb Extinguishers
700287W	Buckeye Bracket For 2.5 lb Extinguishers
700270W	Buckeye Bracket For 5 lb Extinguishers
700430W	Buckeye Bracket For Tall 10 lb Extinguishers



466400K, 466401K



21009952K In Use

VEHICLE BRACKETS. Kidde.

P/N	DESCRIPTION
466400K	Kidde Bracket For 5 & 6 lb Extinguishers
466401K	Kidde Bracket For 2.5 & 2.6 lb Extinguishers

Made to fit a rectangular forklift support, this **FORKLIFT BRACKET** is ideal for hanging an extinguisher.

NOTE: Requires a strap bracket (not included) to secure an extinguisher.

P/N	DESCRIPTION
21009952K	Forklift Bracket



UPB25



UPB5

VEHICLE BRACKETS. Universal.

P/N	DESCRIPTION
UPB25	Universal Bracket For 2.5 & 2.75 lb Extinguishers
UPB5	Universal Bracket For 5 & 6 lb Extinguishers

SPRING CLIP BRACKETS

P/N	DESCRIPTION
2SC	Spring Clip Bracket For 2.5 lb CO ₂ Extinguishers
4SC	Spring Clip Bracket For 5 & 6 lb D/C, Halon, & CO ₂ Extinguishers
15SC	Spring Clip Bracket w/ Hanger For 10 & 15 lb D/C, Halon, & CO ₂ Extinguishers



4SC

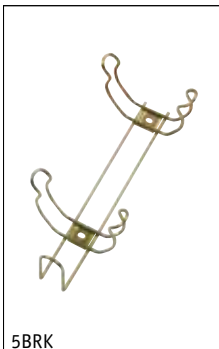

5BRK

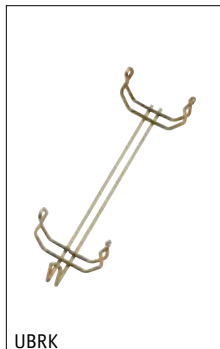

UBRK

SPRING CLIP BRACKETS

P/N	DESCRIPTION
UBRK	Spring Clip Bracket For 2.5 & 2.75 lb D/C & Halon Extinguishers
5BRK	Spring Clip Bracket For 5 & 6 lb D/C & Halon Extinguishers
HWC5	Spring Clip Bracket For 5"-5 1/8" Dia Shells

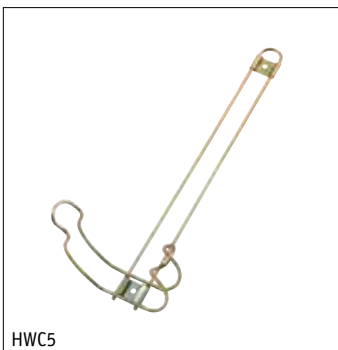

HWC5



25UPB

PLASTIC UNIVERSAL SPRING CLIP BRACKETS

P/N	DESCRIPTION
25UPB	Universal Spring Clip Bracket Fits 2.5 lb Extinguishers
5UPB	Universal Spring Clip Bracket Fits 5 lb Extinguishers
10UPB	Universal Spring Clip Bracket Fits 10 lb Extinguishers

Featuring welded-steel construction, these **VEHICLE BRACKETS** will not vibrate apart. Order **HPIN** separately.

P/N	DESCRIPTION
5DC	Running Board Bracket For 4 ¹ / ₄ "-4 ¹ / ₂ " Dia Shells
807A	Amerex Heavy-Duty Bracket For 4 ¹ / ₄ " Dia Shells
5HB	Running Board Bracket For 4 ⁷ / ₈ "-5 ⁵ / ₈ " Dia Shells
809A	Amerex Heavy-Duty Bracket For 5" Dia Shells
AX809G	Amerex Heavy-Duty Bracket, Galvanized For 5" Dia Shells
10HB	Running Board Bracket For 5 ³ / ₄ "-6 ¹ / ₄ " Dia Shells
366242K	Badger/Kidde Heavy-Duty Bracket For 5 ⁷ / ₈ " Dia Shells
15HB	Running Board Bracket For 6 ¹ / ₂ "-7" Dia Shells
810A	Amerex Heavy-Duty Bracket For 7" Dia Shells
AX810G	Amerex Heavy-Duty Bracket, Galvanized For 7" Dia Shells
AX810CG	Amerex Heavy-Duty Bracket – USCG Models For Models B250CG, B260CG, & B262CG
292474K	Badger/Kidde Heavy-Duty Bracket For 7"-7 ¹ / ₆₄ " Dia Shells
15HBL	Running Board Bracket For 7 ¹ / ₄ "-7 ¹ / ₂ " Dia Shells
20HB	Running Board Bracket For 7 ³ / ₄ "-8" Dia Shells
811A	Amerex Heavy-Duty Bracket For 8" Dia Shells
AX811G	Amerex Heavy-Duty Bracket, Galvanized For 8" Dia Shells
RG	Heavy-Duty Rubber Grommet

VEHICLE BRACKETS for **Ansul** and **General** have steel-bolted construction and include hasps and latch pins. Brackets will not vibrate open (pin must be removed to free extinguisher).

P/N	DESCRIPTION
A10C	10 lb Cartridge-Operated Extinguisher Bracket Ansul Compatible
AG20C	20 lb Cartridge-Operated Extinguisher Bracket Ansul & General Compatible
AG30C	30 lb Cartridge-Operated Extinguisher Bracket Ansul & General Compatible
AGRG	Heavy-Duty Rubber Grommet For Cartridge Bracket
HPIN	"Hair Pin" Clips, Pkg/5

These **VEHICLE BRACKETS** are designed for **Badger™ Brigade** cartridge-operated models.

P/N	DESCRIPTION
466541B	Badger 10 lb Cartridge-Operated Extinguisher Bracket
466542B	Badger 20 lb Cartridge-Operated Extinguisher Bracket
466543B	Badger 30 lb Cartridge-Operated Extinguisher Bracket



5HB



809A



366242K

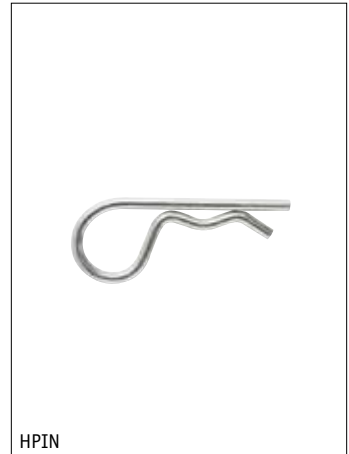

HPIN

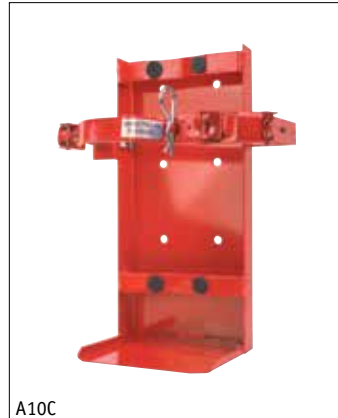

A10C

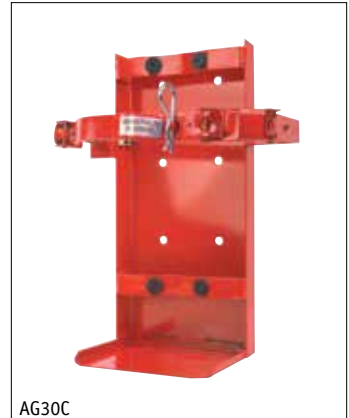

AG30C



466541B



466542B

Make Moving From Jobsite To Jobsite Easy



FES1 In Use

Make moving fire extinguishers from jobsite to jobsite easy with this **PORTABLE EXTINGUISHER STAND**. It holds a 5, 10, or 20 lb dry chemical extinguisher and has a molded-in handle for ease of movement, and a large 2½" fill hole for the addition of sand (up to 35 lb—not included). Constructed of red powder-coated steel, it is pre-drilled for a fire extinguisher wall hook.

P/N	DESCRIPTION	H X W X D
FES1	Portable Extinguisher Stand	48" x 16" x 16"



FGSWC10 In Use



FMRGC In Use

PORTABLE EXTINGUISHER CABINETS & STANDS

solve the problem of locating fire extinguishers on jobsites, project areas, and in remote locations. Constructed from rust/fade proof materials that meet Cal and OSHA requirements, these cabinet/stand combos come with handles for convenient carry. Other standard features include scored break fronts, cylinder locks, heavy-duty rubber stand bases, informational decals, and stackable storage/transport. Units measure 43"H x 20"W x 20"D. White/Red.

P/N	DESCRIPTION	H X W X D
FGSWC10	Portable Cabinet & Stand, 10 lb	
FGSWC20	Portable Cabinet & Stand, 20 lb	

The **Original Firemate** is a stackable **PORTABLE FIRE EXTINGUISHER STAND** that is made of tough HDPE plastic. The stand holds 5, 10, or 20 lb extinguishers and its wide base resists tipping. Meets OSHA requirements. 8"H x 7¼"W x 7¼"D recess for extinguisher. Red.

P/N	DESCRIPTION	H X W X D
FMRGC	Extinguisher Stand	34" x 21" x 21"



859A



FES2 w/ FGC26 In Use

Amerex's HEAVY-DUTY DOLLY CART moves larger, heavier extinguishers with ease. Fits cylinders 7"–8" in diameter.

P/N	DESCRIPTION	H X W X D
859A	Heavy-Duty Dolly Cart	

The **FireTech™ FIBERGLASS STAND** is designed for use with the **FGC26 Fiberglass Cabinet** (not included). Its red finish perfectly matches this cabinet, and it comes with four pre-drilled holes for permanent attachment to docks or other locations, or sand can be added for temporary placement. Mounting holes and hardware for attaching the cabinet to the stand are standard. 8¼" x 11¾" top surface. Red.

P/N	DESCRIPTION	H X W X D
FES2	Fiberglass Stand For FGC26 Cabinet	27½" x 15½" x 15½"

In Use photos may show items not included or available separately.

FIRE EXTINGUISHER PICTOGRAMS

DRY CHEMICAL

400, 400T, 403, 403T, 409T, 410T, 416T, 417, 417T, 425, 425T, 442, 443, 453, 454, 456, 459, 479T, 500, 500T

HALON 1211

344, 344T, 352, 354A, 355T, 358

FIG.	P/N	SERVICE & MAINTENANCE PART DESCRIPTION
1	11823A	Valve Assembly All Dry Chemical
2		Pull Pin
2A	532A	Chain (Nylon) for Pull Pin
3		Tamper Seal
4	2625A	Lever & Rivet
5	1060A	Lever Rivet Only
6	G100H	Gauge - 100 (Halon) 344, 344T
6	G125H	Gauge - 125 (Halon) 352T, 355T
6	G195	Gauge - 195 All Dry Chemical
6	G195H	Gauge - 195 (Halon) 354A, 358
7	9001A	Handle & Rivet 344, 344T
7	9003A	Handle & Rivet 400, 400T, 443, 454, 456, 358, 442, 459
8	1064A	Handle Rivet Only
9	5241A	Collar O-Ring
10	6092A	Valve Stem Assembly
12	1074A	Spring
13	1519A	Siphon Tube Assembly 456
13	6212A	Siphon Tube Assembly 409T, 425, 425T, 416T, 355T, 453, 479T, 500, 500T
14	2162A	Hose & Horn Assembly (.140) 454
14	5248A	Hose & Horn Assembly (.152) 479T, 500, 500T, 443
14	5564A	Hose & Horn Assembly (.191) 456
14	6215A	Hose & Horn Assembly (.147) 453
14	7641A	Hose & Horn Assembly (.149) 400, 400T
14	1253A	Nozzle (.166) 425, 425T
14	1276A	Nozzle (.120) 410T
14	1926A	Nozzle (.129) 417, 417T
14	3211A	Nozzle (.120ST) 403T
14	3741A	Nozzle (.173P) 409T, 416T
14	7115A	Nozzle w/ O-Ring (.098) 352T, A352T
15	1532A	Hose Gasket O-Ring
FIG.	P/N	ACCESSORY PART DESCRIPTION
21		Universal Hose Strap/Clip
N/S	1521A	Wall Hanger 400, 425, 453, 479, 500
N/S	4834A	Wall Hanger 344, 417
N/S	5525A	Wall Hanger 442, 443, 454, 456, 459
N/S	861HA	Heavy-Duty Strap Bracket 355, 400, 409, 453, 479, 500
22	5DC	Heavy-Duty Vehicle Bracket 355, 400, 409, 453, 479, 500
22	5HB	Heavy-Duty Vehicle Bracket 443, 456
N/S	AD21	Recharge Adapter
N/S	HTA11	Hydrostatic Test Adapter

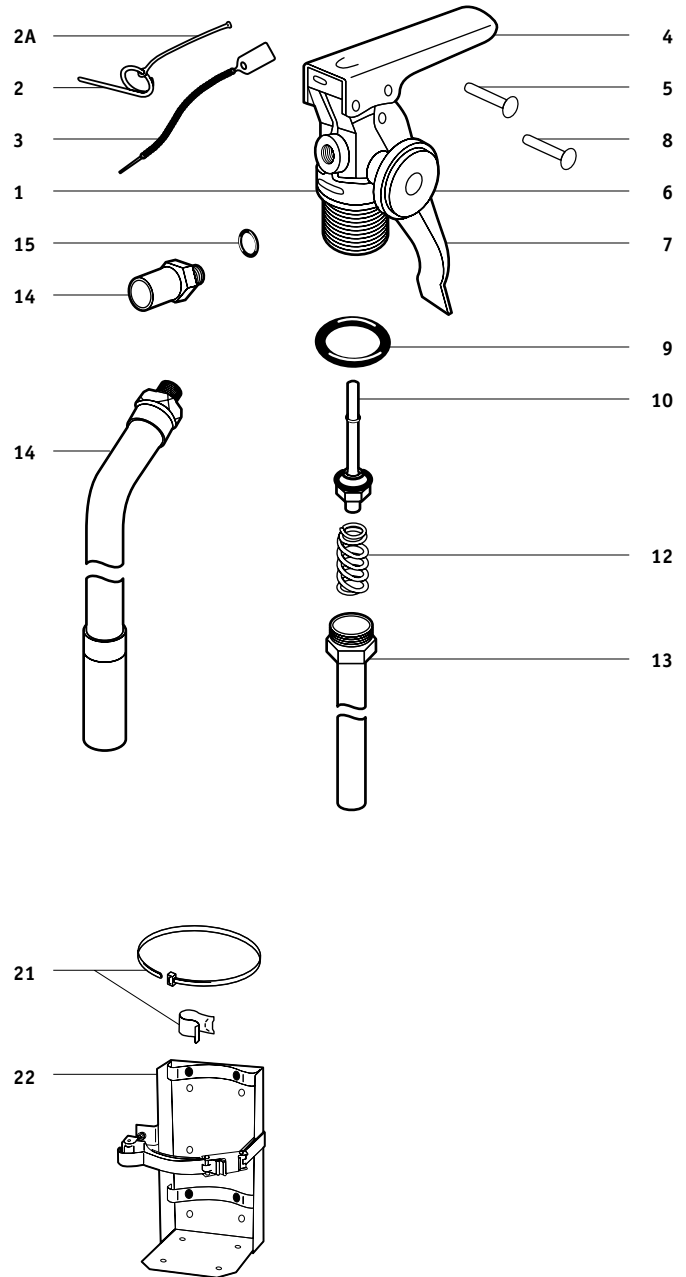

11 AMEREX - FIRE EXTINGUISHER PARTS

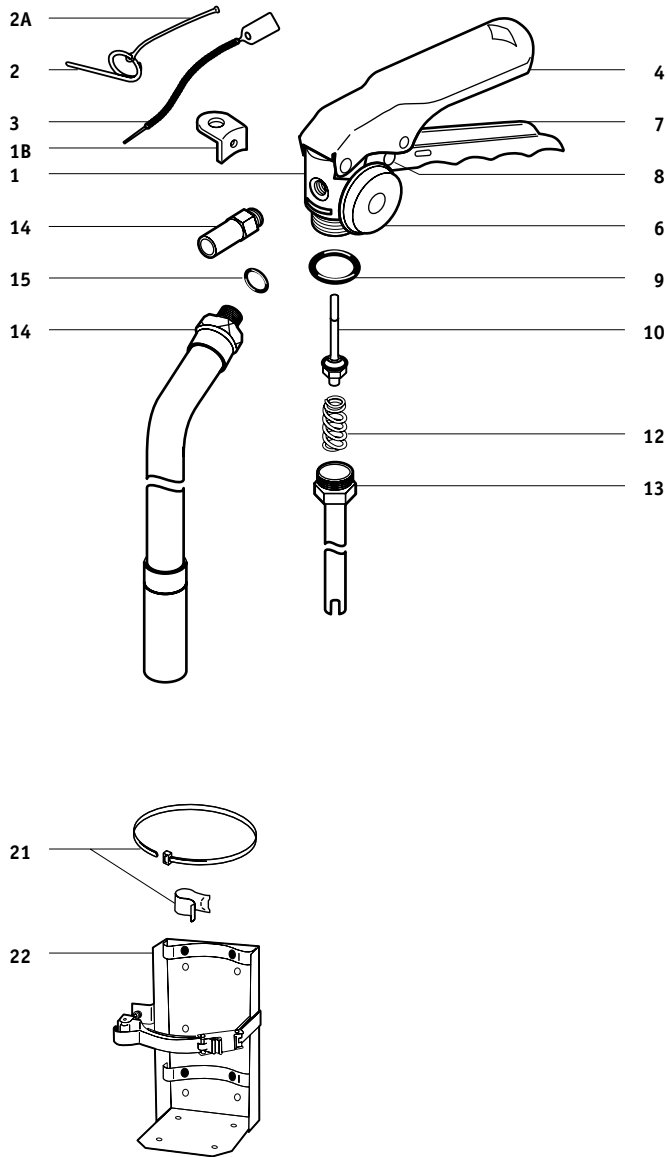

DRY CHEMICAL

A400, A400T, A402, A402T, A403T, A409T, A410T, A411, A412, A413, A416T, A417, A417T, A443, A453, A456, A457, A459, A479T, A500, A500T, A620T, B402, B402T, B403T, B409T, B410T, B416T, B417, B417T, B443, B456, B457, B459, B453, B479T, B500, B500T

HALON 1211

A352T, A354A, C354, A355, A355T, B355T, C352T

HALOTRON I

A384T, A385TS, A386T, B385TS, B386T, B394TS

FIG. P/N SERVICE & MAINTENANCE PART DESCRIPTION

1	11823A	Valve Assembly All Dry Chemical, Except 20 lb, A620T
1	11824A	Valve Assembly 20 lb
1B	14220A	Hanger Loop w/ Screw
2		Pull Pin
2A	532A	Chain (Nylon) for Pull Pin
3		Tamper Seal
4	11825A	Lever & Rivet All, Except A384T
N/S	1060A	Lever Rivet Only
6	G195	Gauge - 195 All Dry Chemical
6	G125H	Gauge - 125 (Halon) A352T, A355T
6	G195H	Gauge - 195 (Halon) A354A, C354
6	G100T	Gauge - 100 (Halotron I) A385TS, A386T
6	G125T	Gauge - 125 (Halotron I) A384T
7	11826A	Handle & Rivet All, Except A620T, A411, A412, A413, A384T
7	12405A	Handle & Rivet A411, A412, A413
8	1064A	Handle Rivet Only All, Except A411, A412, A413
9	5241A	Collar O-Ring All Dry Chemical, Halon 1211
9	14268A	Collar O-Ring (Green) All Halotron I
10	6092A	Valve Stem Assembly All Dry Chemical, Halon 1211
10	14327A	Valve Stem Assembly (Green Seal) All Halotron I
12	1074A	Spring
13	1519A	Siphon Tube Assembly A456, A457, B456, B457
13	11674A	Siphon Tube Assembly A411, A412, A413
13	6212A	Siphon Tube Assembly A402, A402T, A409T, A355T, A453, A479T, A500, A500T, A386T, B402, B402T, B403T, B409T, B410T, B416T, B417, B417T, B453, B479T, B500, B500T, B385TS, B386T
14	11221A	Hose & Horn Assembly (.209) A411
14	5248A	Hose & Horn Assembly (.152) A479T, A443, B479T, B443
14	5564A	Hose & Horn Assembly (.191) A456, A457, B456, B457
14	6215A	Hose & Horn Assembly (.147) A453, A500, A500T, B453, B500, B500T
14	7641A	Hose & Horn Assembly (.149) A400, A400T
14	14849A	Hose & Horn Assembly (.157) A402, A402T, B402, B402T
14	1276A	Nozzle (.120) A410T, B410T
14	1926A	Nozzle (.129) A417, A417T, B417, B417T
14	3211A	Nozzle (.120ST) A403T, B403T
14	3741A	Nozzle (.173P) A409T, A416T, B409T, B416T
14	14407A	Nozzle (.121) A384T
14	14408A	Nozzle (.166) A385TS
14	14409A	Nozzle (.277) A386T

CONTINUED FROM PAGE 250

FIG.	P/N	SERVICE & MAINTENANCE PART DESCRIPTION
14	7115A	Nozzle w/ O-Ring (.098), Pkg/3 A352T
15	6978A	Hose Gasket (O-Ring) A411, A412, A413
15	1532A	Hose Gasket (O-Ring) All 5, 5½, 6, 10 lb
FIG.	P/N	ACCESSORY PART DESCRIPTION
21		Universal Hose Strap/Clip
N/S	1521A	Wall Hanger A386T, A400, A402, A453, A479T, A500, B402*, B453, B479T, B500* (*Thru 2007)
N/S	16591A	Wall Hanger B402, B500 (2008 & Later)
N/S	4834A	Wall Hanger A384T, A385TS, A403T, A410T, A417, A620T, B403T, B410T, B417T
N/S	5525A	Wall Hanger A443, A456, A457, B456, B457
N/S	WH2	Wall Hanger A411, A412, A413
N/S	861HA	Heavy-Duty Strap Bracket A355, A400, A402, A409, A453, A479, A500
22	5DC	Heavy-Duty Vehicle Bracket A355, A400, A402, A409, A453, A479, A500, B402, B409, B453, B479, B500, B386T
22	5HB	Heavy-Duty Vehicle Bracket A443, A456, A457, B456, B457
22	15HB	Heavy-Duty Vehicle Bracket A411, A412, A413
N/S	AD21	Recharge Adapter All, Except A411, A412, A413
N/S	AD24	Recharge Adapter A411, A412, A413
N/S	HTA11	Hydrostatic Test Adapter

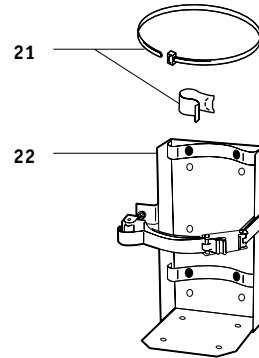
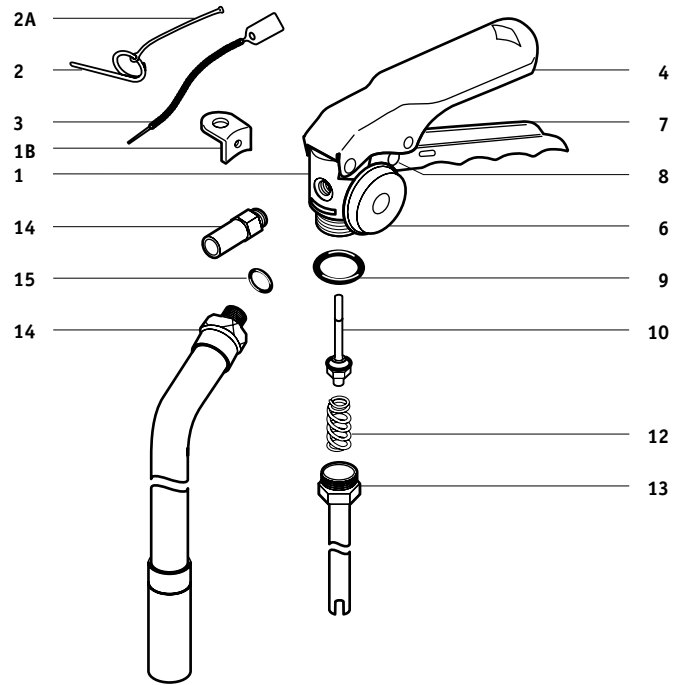

11 AMEREX - FIRE EXTINGUISHER PARTS

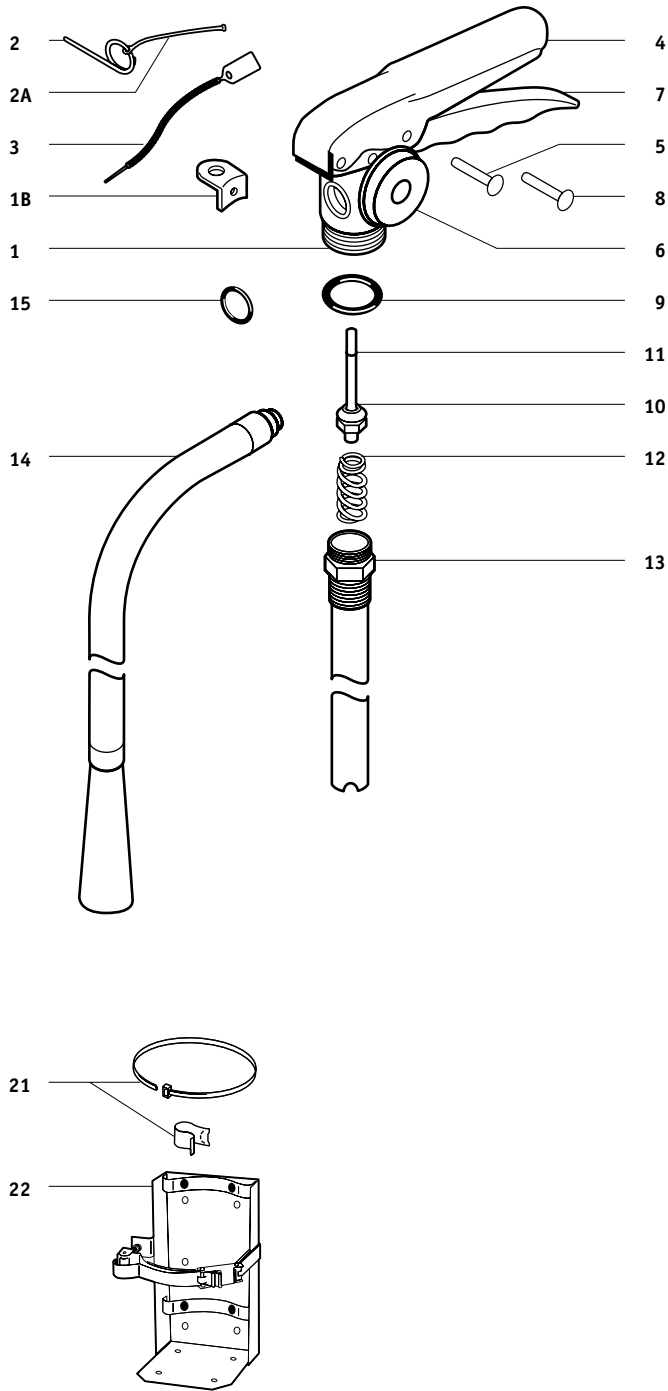

DRY CHEMICAL

408, 415, 418T, 419, 423, 424, 441, 447, 460, 461, 462, B424, B441, B447, B460, B461, B462, 692, 693

HALON 1211

357, 361, 369, B369, 371, B371, 372

HALOTRON I

387, 388, 397, 398

CLASS D

570, 571, B570, B571

FIG. P/N SERVICE & MAINTENANCE PART DESCRIPTION

1	11952A	Valve Assembly All Dry Chemical, Class D
1B	15363A	Hanger Loop w/ Screw B441, B447, B460, B461, B462, B371
2		Pull Pin, Stainless Steel
2A	532A	Chain (Nylon) for Pull Pin
3		Tamper Seal
4	7762A	Lever & Rivet
5	1563A	Lever Rivet Only
6	G195	Gauge - 195 All Dry Chemical, Class D
6	G125H	Gauge - 125 (Halon)
6	G195H	Gauge - 195 (Halon) 361, 369, B369, 371, B371, 372
6	G125T	Gauge - 125 (Halotron I) 387, 388, 397, 398
7	9020A	Handle & Rivets
8	1564A	Handle Rivet Only
9	5240A	Collar O-Ring All Dry Chemical, Halon 1211
9	13305A	Collar O-Ring (Green) All Halotron I
10	6093A	Valve Stem Assembly All Dry Chemical & Halon 1211
10	13288A	Valve Stem Assembly (Green Seals) All Halotron I
11	5243A	Valve Stem O-Ring
12	383A	Spring
13	1667A	Siphon Tube 408, 415, 423
13	2609A	Siphon Tube 441, 447, 460, B441, B447, B460
14	1178A	Hose & Horn Assembly (.173) 447, 441, B447, B441
14	1945A	Hose & Horn Assembly (.157) 424, B424
14	3339A	Hose & Horn Assembly (.174) 423
14	6095A	Hose & Horn Assembly (.152) 419, 460, B460
N/S	Z10744AD	Hose Assembly* 570, 571, B570, B571
N/S	Z9073AD	O-Ring* 570, 571, B570, B571
N/S	Z10800AD	Extension Applicator, w/ Horn & Quick Connect* 570, 571, B570, B571
N/S	Z14595AD	Horn* 570, 571, B570, B571
N/S	Z10802AD	Female Quick Connect* 570, 571, B570, B571
15	6978A	Hose Gasket (O-Ring)

FIG. P/N ACCESSORY PART DESCRIPTION

21		Universal Hose Strap/Clip
N/S	WH2	Wall Hanger All, Except 418T, 387, 388
N/S	861HA	Heavy-Duty Strap Bracket 357, 424
22	5DC	Heavy-Duty Vehicle Bracket 357, 424
22	5HB	Heavy-Duty Vehicle Bracket 369, 371, 441, 447, 460, 461, 462
22	10HB	Heavy-Duty Vehicle Bracket 419
22	15HB	Heavy-Duty Vehicle Bracket 361, 372, 408, 415, 423
N/S	AD24	Recharge Adapter
N/S	HTA9	Hydrostatic Test Adapter

*NOTE: These parts fit extinguishers manufactured after Aug. 1991 and can be retrofitted to earlier models, provided that all parts are replaced.

DRY CHEMICAL (High Performance)

564, 566, 567, 568, 569, 580, 581, 582, 584, 589, 591, 592, 594, 595, 599

FIG. P/N SERVICE & MAINTENANCE PART DESCRIPTION

1B	9584A	Hanger Loop w/ Screw
2		Pull Pin, Stainless Steel
2A	532A	Chain (Nylon) for Pull Pin
3		Tamper Seal
4	9840A	Lever & Rivet
5	1563A	Lever Rivet Only
6	G240	Gauge - 240
7	9020A	Handle & Rivets
8	1564A	Handle Rivet Only
9	5240A	Collar O-Ring
10	6093A	Valve Stem Assembly
11	5243A	Valve Stem O-Ring
12	383A	Spring
13	1667A	Siphon Tube
14	14787A	Hose & Horn Assembly (.166) 564 (Oct. 1999 & later)
14	14786A	Hose & Horn Assembly (.157) 566 (Oct. 1999 & later)
14	14789A	Hose & Horn Assembly (.312) 567, 568, 569, 584 (Oct. 1999 & later)
15	6978A	Hose Gasket (O-Ring)

FIG. P/N ACCESSORY PART DESCRIPTION

N/S		Universal Hose Strap/Clip All 1999 later
N/S	AD36	Recharge Adapter All Prior to 1999
N/S	AD24	Recharge Adapter All 1999 later
N/S	HTA9	Hydrostatic Test Adapter

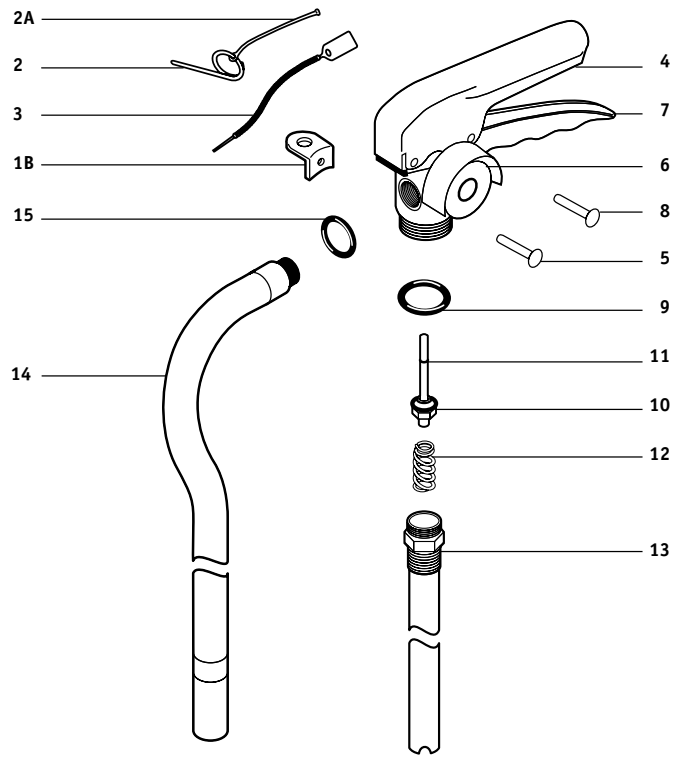

11 AMEREX - FIRE EXTINGUISHER PARTS

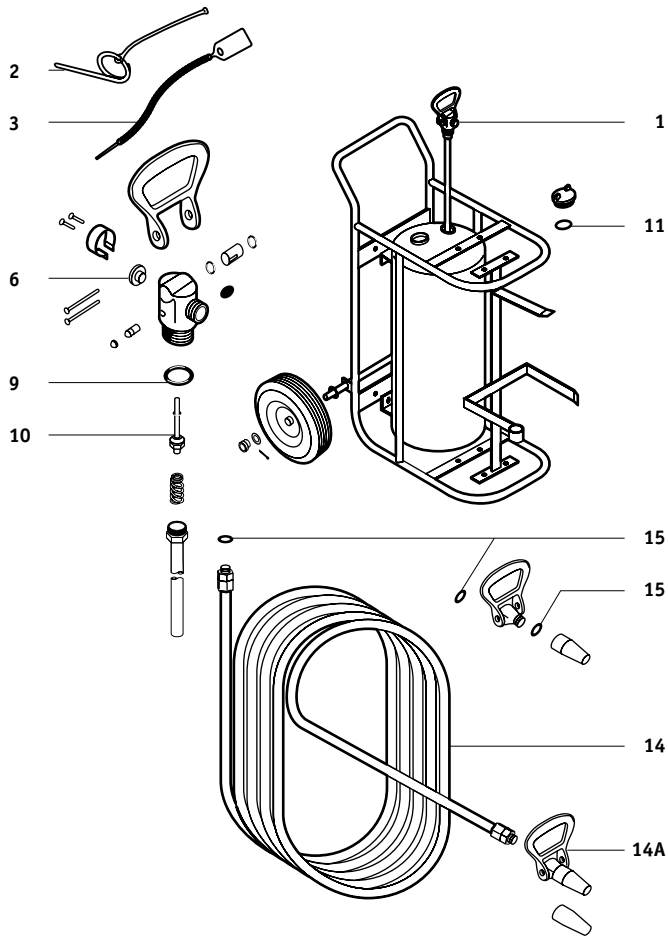

DRY CHEMICAL
 476, 477, 478, 488, 489, 490
HALON 1211
 600, 610
HALOTRON I
 673, 674, 675, B674, B675

FIG.	P/N	SERVICE & MAINTENANCE PART DESCRIPTION
1	5197AD	Valve Assembly w/ Siphon Tube (Special Order) Dry Chemical
N/S	3787A	Safety Disc Assembly
2		Large Loop Pull Pin
3		Tamper Seal
6	G240	Gauge - 240 Dry Chemical
6	G100T	Gauge - 100 (Halotron I) 673
6	G125T	Gauge - 125 (Halotron I) 674, 675
9	5239A	Collar O-Ring Dry Chemical & Halon 1211
10	5067A	Valve Stem Assembly Dry Chemical & Halon 1211
11	8392A	Fill Cap Gasket Dry Chemical
14	3501AD	Hose, 3/4" x 50' (Special Order)
14A	Z5191AD	Nozzle Assembly - Ball Valve & Tip (Special Order) 476, 477, 488, 489
14A	Z7432AD	Nozzle Assembly - Ball Valve & Tip (Special Order) 478, 490
14A	Z5295AD	Nozzle Assembly - Ball Valve & Tip (Special Order) 600, 610
15	3877A	Nozzle & Hose Gasket
FIG.	P/N	ACCESSORY PART DESCRIPTION
N/S	AV1	Air Valve
N/S	5720A	Recharge/Hose Hydrotest Adapter
N/S	HTA24	Hydrotest Adapter Cylinder

CYLINDER OPERATED DRY CHEMICAL

450, 451, 452, 467, 468, 469, 470, 471, 472

FIG.	P/N	SERVICE & MAINTENANCE PART DESCRIPTION
2	2272A	Gasket, Cap
5	12467A	Nitrogen Valve w/ Gauge T-Handle, Quick-Release Valve
N/S	9897AD	Valve Stem Assembly T-Handle, Quick-Release Valve
6	G3000	Gauge - 3000
8	2234A	Nitrogen Hose Assembly 467, 468, 469, 470, 471, 472
8	3818AD	Nitrogen Hose Assembly 450, 451, 452
9	7411A	Moisture Seal
10	3877A	Gasket, Hose, & Nozzle
11	3501AD	Hose Assembly, 50' (Special Order)
12	6717AD	Nozzle Assembly 450, 451, 452

FIG.	P/N	ACCESSORY PART DESCRIPTION
N/S	4892A	Hydrostatic Test Adapter, Cylinder
N/S	5720A	Hydrostatic Test Adapter, Hose

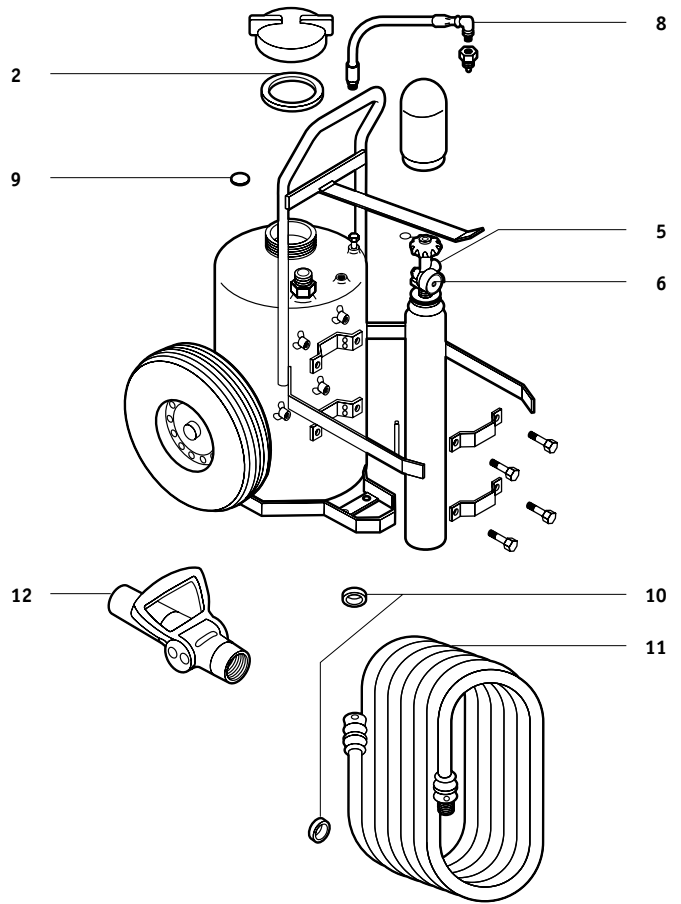

DRY CHEMICAL

473, 474, 475, 495, 496, 497

HALON 1211

611, 695

FIG.	P/N	SERVICE & MAINTENANCE PART DESCRIPTION
1	Z6018AD	Valve Assembly w/ Siphon Tube (Special Order) Dry Chemical
2		Large Loop Pull Pin
3		Tamper Seal
6	G240	Gauge - 240 Dry Chemical
9	5240A	Collar O-Ring
10	6022A	Valve Stem Assembly
12	383A	Spring
14	6015A	Hose, 1/2" x 25' (Special Order)
14A	Z6395AD	Nozzle Assembly—Ball Valve & Tip (Special Order) 496 Dry Chemical, 695 Halon
14A	Z6396AD	Nozzle Assembly—Ball Valve & Tip (Special Order) 497
14C	3877A	Nozzle Gasket

FIG.	P/N	ACCESSORY PART DESCRIPTION
N/S	AV1	Air Valve
N/S	6160A	Recharge Adapter
N/S	HTA9	Hydrotest Adapter

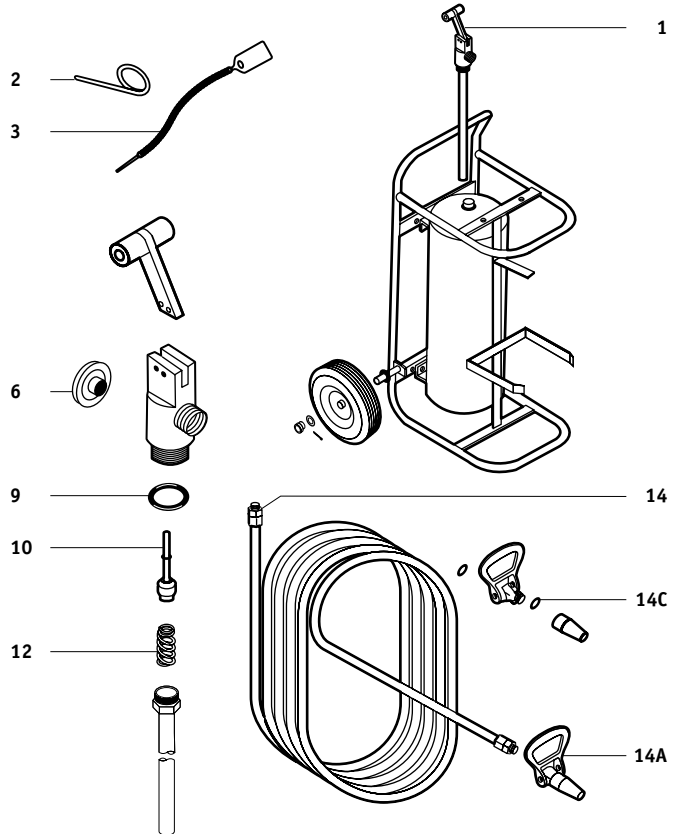

11 AMEREX - FIRE EXTINGUISHER PARTS

CARBON DIOXIDE

322, 330, 331, 332

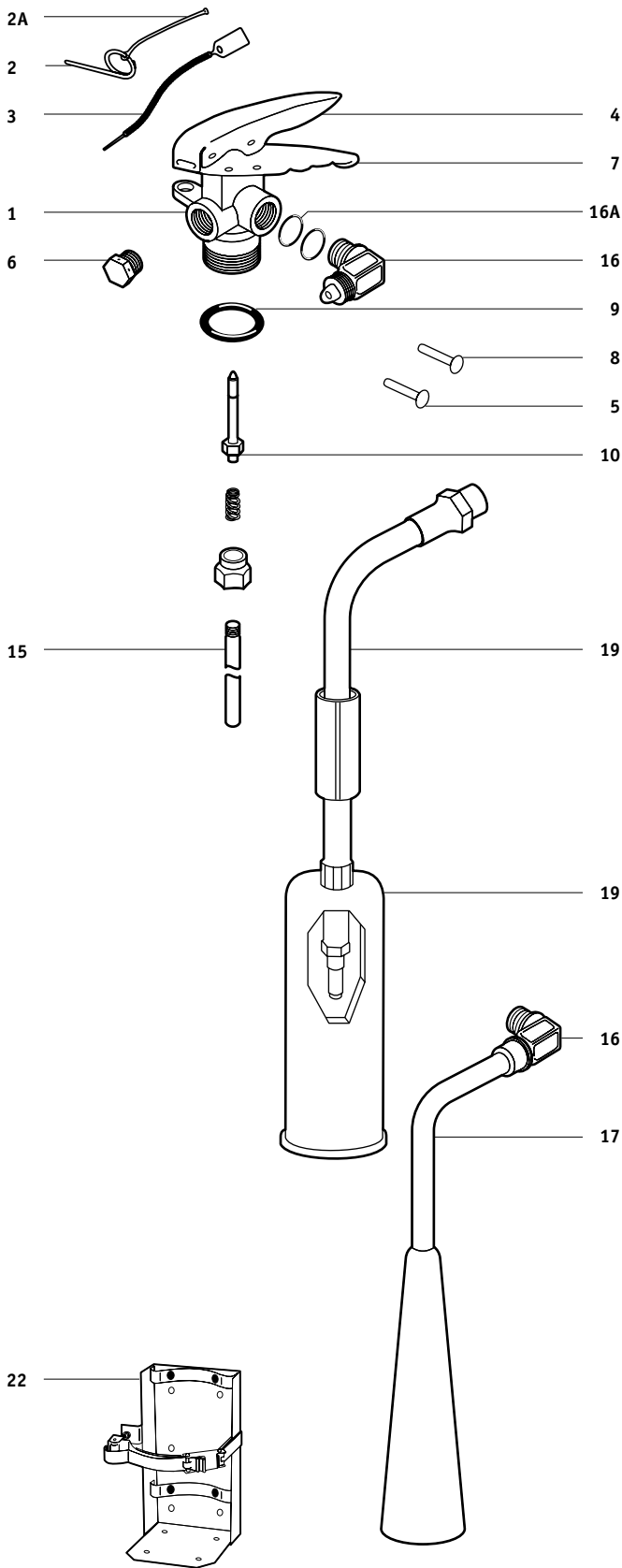

FIG.	P/N	SERVICE & MAINTENANCE PART DESCRIPTION
1	3090A	Valve Assembly w/o Elbow or Siphon Tube
2		Pull Pin, Stainless Steel
2A	532A	Chain (Nylon) for Pull Pin
3		Tamper Seal
4	7762A	Lever & Rivet
5	1563A	Rivet Only for Lever
6	4000A	Safety Disc, Gasket, & Nut Assembly
7	9020A	Handle & Rivets
8	1564A	Handle Rivet Only
9	1124A	Collar O-Ring
10	1539A	Valve Stem Assembly
15	564A	Siphon Tube
15	589A	Siphon Tube
15	533A	Siphon Tube
16	2309A	Elbow w/ O-Ring & Spacer
16	2735A	Elbow w/ O-Ring
16A	5689A	O-Ring for Elbow
17	1769A	Discharge Tube
19	1782A	Hose & Horn Assembly
19	1705A	Hose & Horn Assembly

FIG.	P/N	ACCESSORY PART DESCRIPTION
N/S	AX20570	Strap & Clip
N/S	AX20571	Strap & Clip
N/S	RDS20	Strap
N/S	RDS15	Strap
N/S	RDBACLIP	Horn Clip
N/S	SET6	Hardware Set
N/S	BL209	Replacement Nameplate 5 lb (Non-UL)
N/S	BL210	Replacement Nameplate 10-20 lb (Non-UL)
N/S	WH5	Wall Hanger
N/S	WH15	Wall Hanger
N/S	WH20	Wall Hanger
22	5HB	Heavy-Duty Vehicle Bracket
22	15HB	Heavy-Duty Vehicle Bracket
22	20HB	Heavy-Duty Vehicle Bracket

WATER/FOAM/LOADED STREAM

240, 250, 250CG, 252, 254

WET CHEMICAL

260, 262, B260, B262

WATER MIST

270, 272, B270, B272, B270NM, B272NM

FIG.	P/N	SERVICE & MAINTENANCE PART DESCRIPTION
2		Pull Pin, Stainless Steel
2A	532A	Chain (Nylon) for Pull Pin
3		Tamper Seal
4	7762A	Lever & Rivet
5	1563A	Lever Rivet Only
6	G100WS	Gauge - 100
6	G100K	Gauge - 100 All, Except Wet Chemical Models
7	9020A	Handle & Rivets
8	1564A	Handle Rivet Only
9	5240A	Collar O-Ring
10	6093A	Valve Stem Assembly All, Except Wet Chemical
10	14878A	Valve Stem Assembly All Wet Chemical
11	5243A	Valve Stem O-Ring
12	383A	Spring
13	15941A	Siphon Tube Assembly 254, 270, B270, B270NM
13	15943A	Siphon Tube Assembly 240, 250, 252, 272, B272, B272NM
13	16266A	Siphon Tube Assembly B260
13	16267A	Siphon Tube Assembly B262
13A	5690A	O-Ring - Siphon Tube
14	14588A	Hose & Wand Assembly (Replaces 13576) 260, 262
14	16043A	Hose & Nozzle Assembly B260
14	16101A	Hose & Nozzle Assembly B262
14	6982A	Hose & Aspirated Nozzle Assembly 252
14	6999A	Hose & Nozzle Assembly 240
14	7000A	Hose & Aspirated Nozzle Assembly 250
14	14184A	Hose & Nozzle Assembly 272, B272, B272NM
15	6978A	Hose Gasket (O-Ring)
18	3109A	Foot Stand (Black) 260, 262, B260, B262
18	3576A	Foot Stand w/ Clip (Black) 240
18	3776A	Foot Stand w/ Post (Black) 250, 252
19	2595A	Fill Tube
N/S	AX502AR	Model 502, 23 oz, AR-AFFF Premix Charge 250, 250CG, 252, 254
N/S	AX506B2	Anti-Freeze Charge, Pkg/2
N/S	AX5302	Wet Chemical Recharge, 6 L
N/S	AX660	Wet Chemical Charge, 2.5 gal
N/S	AX6702	Deionized Water Charge, 6 L
N/S	AX6712	Deionized Water Charge, 2.5 gal

FIG.	P/N	ACCESSORY PART DESCRIPTION
1A	AV1	Pressure Valve & Cap Assembly
N/S	CORE	Pressure Valve Core, Pkg/50
N/S	AVC	Pressure Cap, Pkg/50
21	14838A	Hose Strap & Clip 270, 272, B270, B272, B270NM, B272NM
21	LCC38	Universal Hose Strap/Clip 260, 262, B260, B262
22	15HB	Heavy-Duty Vehicle Bracket
N/S	AD24	Recharge Adapter 250, 252, 254, 260, 262 (w/o Air Valves)
N/S	AD36	Recharge Adapter 270, 272, B260, B262, B270, B272, B270NM, B272NM
N/S	HTA10	Hydrostatic Test Adapter

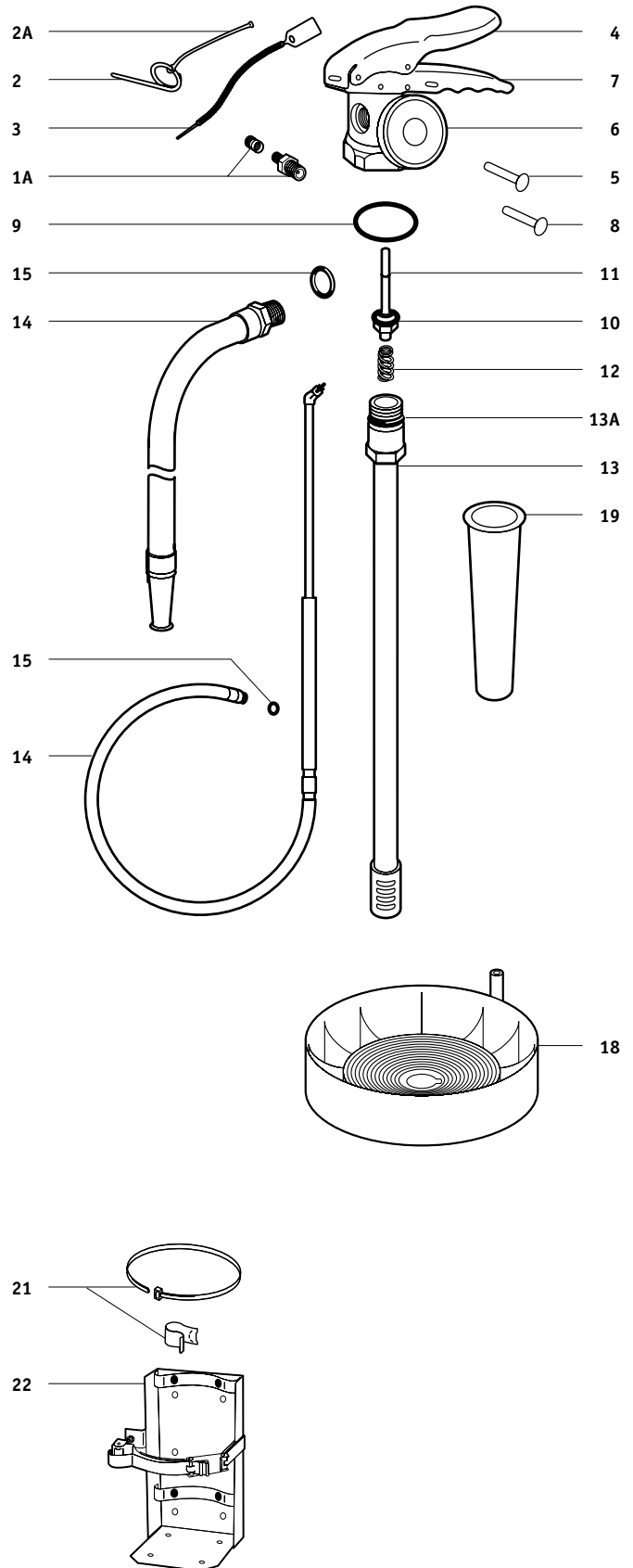

11 ANSUL - FIRE EXTINGUISHER PARTS

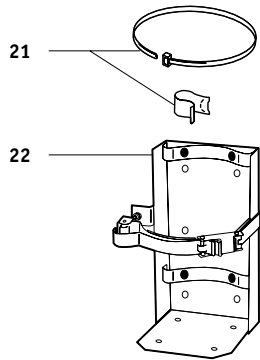
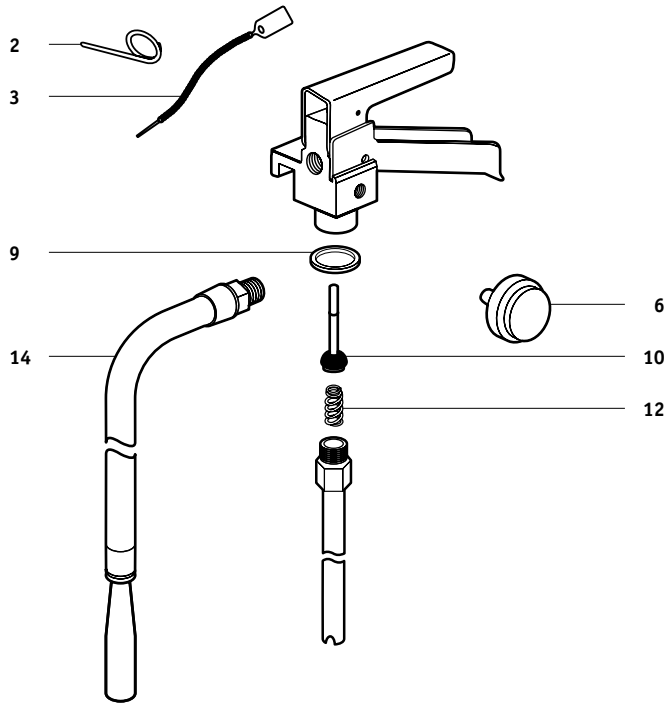

DRY CHEMICAL

SY-0513, SY-0514, SY-0613, SY-0614, SY-0623, SY-0624, SY-0633, SY-0634, SY-1013, SY-1014, SY-1015, SY-1023, SY-1024, SY-1033, SY-1034, SY-2013, SY-2014, SY-2023, SY-2024, SY-2033, SY-2034

HALON 1211

SY-0541, SY-0942, SY-1441, SY-1741

CLEANGUARD (FE36)

CA-0581, CA-0681, CA-0981, CA-1081, CA-1381, CA-1481

FIG. P/N SERVICE & MAINTENANCE PART DESCRIPTION

2		Pull Pin
3		Tamper Seal
6	G100H	Gauge - 100 (Halon)
6	G125H	Gauge - 125 (Halon)
6	G195	Gauge - 195 All Dry Chemical
6	G195H	Gauge - 195 (Halon)
6	428940AS	Gauge (FE36) (Replaces 419493) All Cleanguard
9	16222AS	Collar Quad Ring All Dry Chemical
9	21882AS	Collar Quad Ring All Halon, Cleanguard
10	ASVS4	Valve Stem Assembly
12	29256AS	Spring
14	30617AS	Hose & Nozzle Assembly SY-2013, 2014, 2033, 2034
14	30618AS	Hose & Nozzle Assembly SY-2023, 2024

FIG. P/N ACCESSORY PART DESCRIPTION

21		Universal Hose Strap/Clip
22	10HB	Heavy-Duty Vehicle Bracket 9-14 lb
22	15HB	Heavy-Duty Vehicle Bracket 17, 20 lb
N/S	ASWH2	Wall Hanger Up to 9 lb, SY-1015
N/S	ASWH3	Wall Hanger 10, 14 lb (Except SY-1015)
N/S	ASWH4	Wall Hanger 17, 20 lb
N/S	AD30	Recharge Adapter
N/S	HTA9	Hydrostatic Test Adapter

DRY CHEMICAL

SY-0212, SY-0214, SY-0215, SY-0216, SY-0236, SY-0515, SY-0516, SY-0517, SY-0521, SY-0531, SY-0635

HALON 1211

SY-0241, SY-0242, SY-0243

FIG.	P/N	SERVICE & MAINTENANCE PART DESCRIPTION
2		Pull Pin
3		Tamper Seal
4	ASL1	Lever (Replaces 68169)
5	25719AS	Lever Rivet
6	G100H	Gauge - 100 (Halon)
6	G195	Gauge - 195 All Dry Chemical
7	ASH1	Handle (Replaces 79119)
8	25720AS	Handle Rivet
9	79122AS	Collar O-Ring (Replaces Quad-Ring 25765) Dry Chemical
10	ASVS5	Valve Stem Assembly All Dry Chemical, Except SY-0516, 0517, 0521, 0531
10	429099AS	Valve Stem Assembly SY-0516, 0517, 0521, 0531, SY-0241, 0242, 0243
12	415565AS	Spring SY-0516, 0517, 0521, 0531
14	ASN1	Nozzle (Replaces 27099) SY-0212, 0214, 0215, 0216
14	54444AS	Nozzle SY-0515 w/o Hose
15	16047AS	O-Ring, Nozzle SY-0212, 0214, 0215, 0216, 0236, 0515

FIG.	P/N	ACCESSORY PART DESCRIPTION
21		Universal Hose Strap/Clip
N/S	24610AS	Bracket Assembly SY-0212, 0214, 0216, 0236
N/S	415824AS	Bracket Assembly SY-0516, 0517, 0521, 0531
22	5DC	Heavy-Duty Vehicle Bracket SY-0516, 0517, 0521, 0531
N/S	AD22	Recharge Adapter SY-0212, 0214, 0215, 0216, 0236, 0515
N/S	AD35	Recharge Adapter SY-0516, 0517, 0521, 0531
N/S	HTA11	Hydrostatic Test Adapter

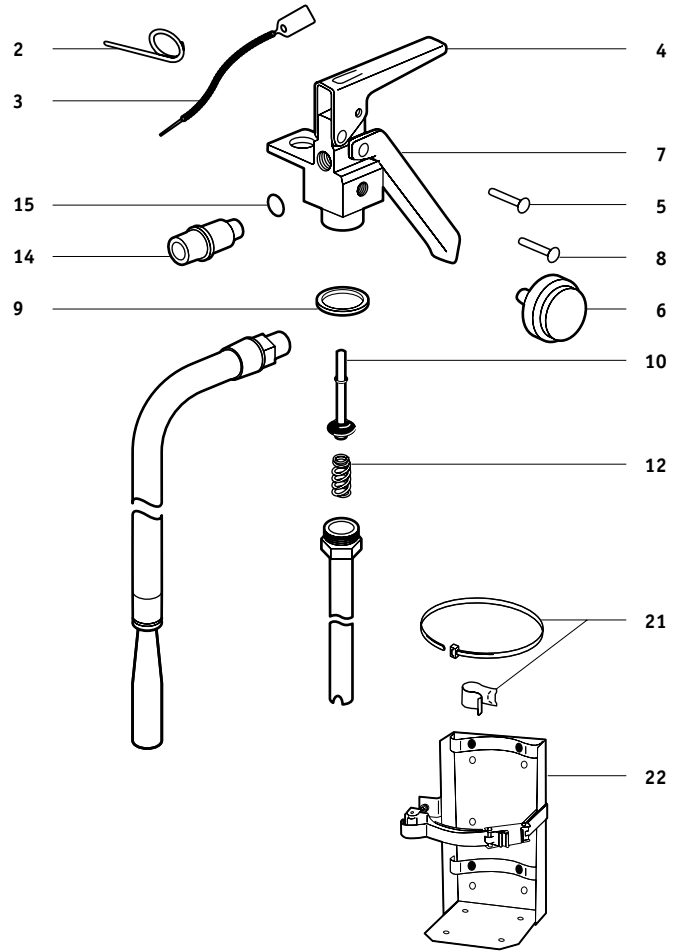

11 ANSUL - FIRE EXTINGUISHER PARTS

DRY CHEMICAL

A10I, AA10SI, PK10I, PK10SI, A20I, AA20I-1, PK20I

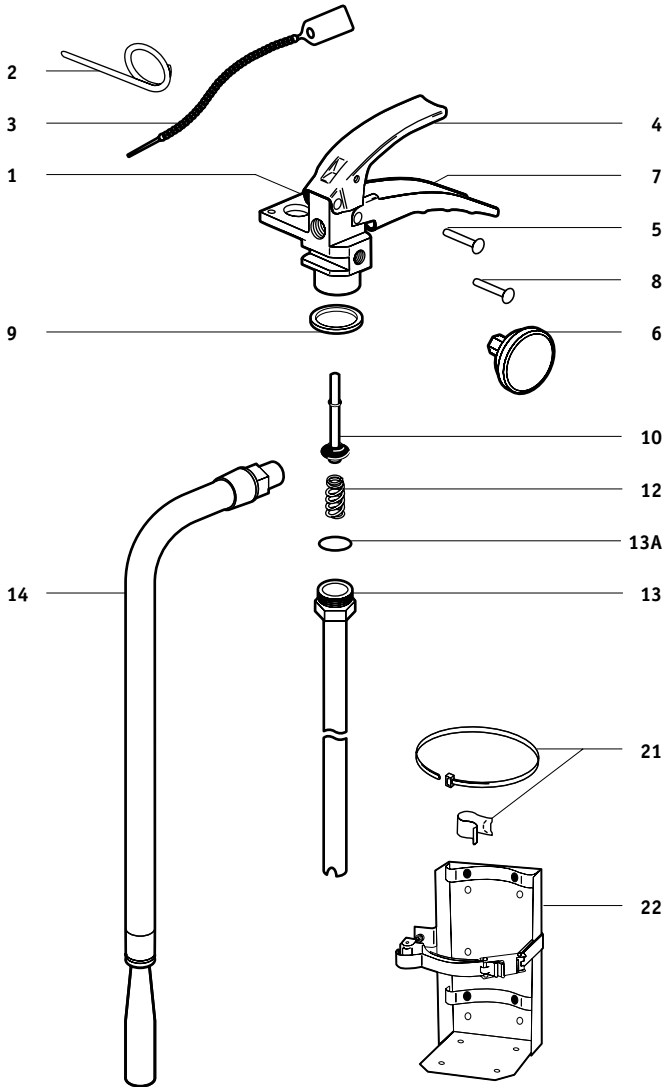

FIG. P/N SERVICE & MAINTENANCE PART DESCRIPTION

2		Pull Pin
3		Tamper Seal
4	428428AS	Lever
5	428130AS	Lever Rivet
6	G195	Gauge - 195
7	428429AS	Handle
8	428130AS	Handle Rivet
9	428327AS	Collar O-Ring
10	428431AS	Valve Stem Assembly
12	415565AS	Spring
→ 13	436843AS	Siphon Tube All 10 lb, Except AA10SI & PK10SI
→ 13	437091AS	Siphon Tube AA10SI, PK10SI
→ 13	436845AS	Siphon Tube All 20 lb
13A	76076AS	Siphon Tube O-Ring
14	428733AS	Hose & Nozzle Assembly A10I, C10I
12	428735AS	Hose & Nozzle Assembly PK10I
13A	428737AS	Hose & Nozzle Assembly A20I, AA20I-1
14	428739AS	Hose & Nozzle Assembly PK20I

FIG. P/N ACCESSORY PART DESCRIPTION

21		Universal Hose Strap/Clip
22	10HB	Heavy-Duty Vehicle Bracket All 10 lb
22	15HB	Heavy-Duty Vehicle Bracket All 20 lb
N/S	WH15	Wall Hanger All 10 lb
N/S	WH20	Wall Hanger All 20 lb
N/S	AD23	Recharge Adapter
N/S	HTA43	Hydrostatic Test Adapter

DRY CHEMICAL

A02, A02VB, A02S, A02SVB, C02, A05, A05VB, AA05, AA05VB, AA05-1, AA05-1VB, A05S, A05SVB, AA05S-1, AA05S-1VB, PK05, PK05S, C05, A10H, A10T, AA10S, PK10, PK10S, C10, C10S, AA20, AA20-1, PK20, C20

CLEANGUARD (FE36)

FE02VB, FE05, FE05S, FE09, FE13

FIG.	P/N	SERVICE & MAINTENANCE PART DESCRIPTION
1	429084ASD	Valve Assembly All 5 lb, Except A05S, AA05S-1, & Cleanguard
1	429085ASD	Valve Assembly A10H, C10, PK10
1	429087ASD	Valve Assembly All 20 lb
2		Pull Pin
3		Tamper Seal
4	429096AS	Lever All Except A02S, A02SVB
5	428130AS	Lever Rivet
6	G125	Gauge - 125 A02S, A02SVB
6	G195	Gauge - 195 All Dry Chemical Except A02S, A02SVB
6	426264AS	Gauge (FE36) FE02VB, FE05
6	428940AS	Gauge (FE36) FE09, FE13
7	429097AS	Handle All Except A02S, A02SVB
8	428130AS	Handle Rivet
9	428327AS	Collar O-Ring
10	429099AS	Valve Stem Assembly
12	415565AS	Spring
→ 13	436841AS	Siphon Tube A02, A02VB, C02
→ 13	436758AS	Siphon Tube A02S, A02SVB
→ 13	436842AS	Siphon Tube A05, A05VB, AA05, AA05VB, AA05-1, AA05-1VB, PK05, C05
→ 13	442367AS	Siphon Tube A05S, A05SVB, AA05S-1, AA05S-1VB, PK05S
→ 13	436843AS	Siphon Tube A10H, PK10, C10
→ 13	436844AS	Siphon Tube A10T
→ 13	437091AS	Siphon Tube AA10S, PK10S, C10S
→ 13	436845AS	Siphon Tube AA20, AA20-1, PK20, C20
13	428795AS	Siphon Tube FE02VB
13	428796AS	Siphon Tube FE05
→ 13	442367AS	Siphon Tube FE05S
13	428797AS	Siphon Tube FE09
13	428799AS	Siphon Tube FE13
13A	76076AS	Siphon Tube O-Ring
14	428269AS	Nozzle A02, A02VB
→ 14	442405AS	Nozzle A02S, A02SVB
14	428729AS	Hose & Nozzle Assembly AA05, AA05VB
14	428728AS	Hose & Nozzle Assembly A05, A05VB
14	434908AS	Hose & Nozzle Assembly AA05-1, AA05VB-1
14	442350AS	Hose & Nozzle Assembly A05S, A05SVB
14	442354AS	Hose & Nozzle Assembly AA05S-1, AA05S-1VB
14	428732AS	Hose & Nozzle Assembly A10T, A10H, C10, C10S
14	436592AS	Hose & Nozzle Assembly AA10S

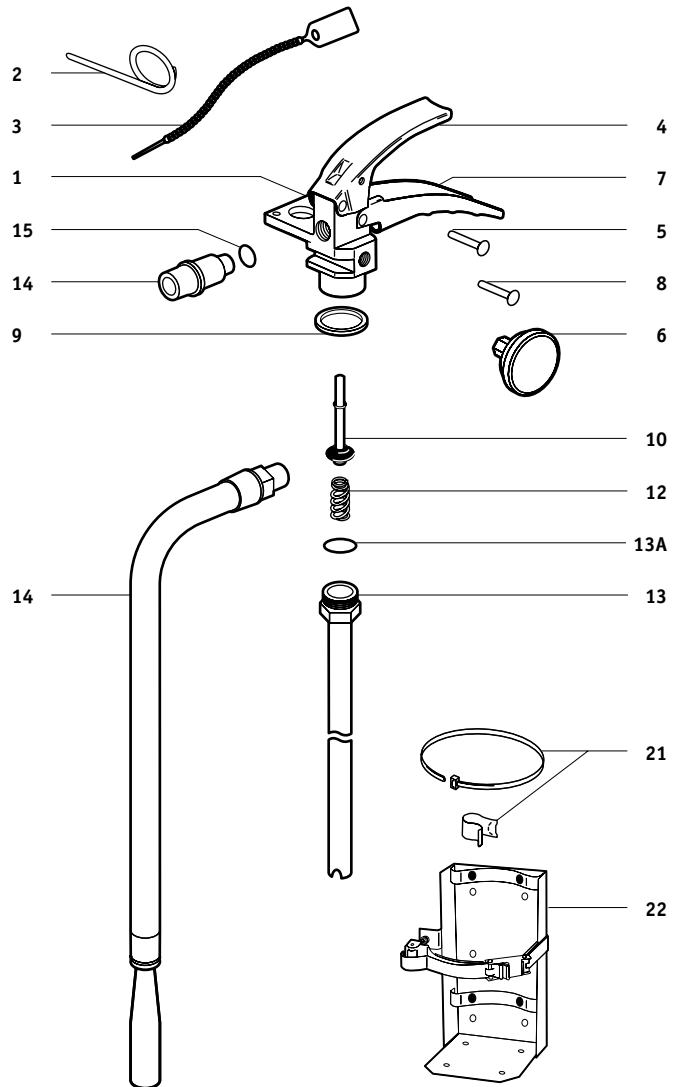

FIG.	P/N	SERVICE & MAINTENANCE PART DESCRIPTION
14	428734AS	Hose & Nozzle Assembly PK10, PK10S
14	428736AS	Hose & Nozzle Assembly AA20, AA20-1
14	428738AS	Hose & Nozzle Assembly PK20
14	428740AS	Hose & Nozzle Assembly C20
15	57744AS	Nozzle O-Ring FE02VB

FIG.	P/N	ACCESSORY PART DESCRIPTION
21		Universal Hose Strap/Clip
22	5DC	Heavy-Duty Vehicle Bracket 5 lb
22	10HB	Heavy-Duty Vehicle Bracket 9-14 lb
22	15HB	Heavy-Duty Vehicle Bracket 17, 20 lb
N/S	WH5	Wall Hanger Up to 9 lb
N/S	WH15	Wall Hanger 10, 14 lb
N/S	WH20	Wall Hanger 17, 20 lb
N/S	AD23	Recharge Adapter
N/S	AD38	Recharge Adapter A02S, A02SVB
N/S	HTA43	Hydrostatic Test Adapter

11 ANSUL - FIRE EXTINGUISHER PARTS

WATER & WET CHEMICAL

W02, K01

FIG. P/N SERVICE & MAINTENANCE PART DESCRIPTION

2		Pull Pin, Stainless Steel
3		Tamper Seal
6	G100WS	Gauge - 100
10	552144FG*	Valve Stem Assembly
N/S	A430182	PRX Liquid Agent, 6 L K01
N/S	A423320	PRX Liquid Agent, 5 gal K01

FIG. P/N ACCESSORY PART DESCRIPTION

1A	AV1	Pressure Valve & Cap Assembly W02
N/S	CORE	Pressure Valve Core, Pkg/50 W02
N/S	AVC	Pressure Cap, Pkg/50 W02
21		Universal Hose Strap/Clip
22	15HB	Heavy-Duty Vehicle Bracket
N/S	WH20	Wall Hanger
N/S	AD24	Recharge Adapter K01
N/S	HTA46	Hydrostatic Test Adapter
N/S	429656AS	Service Manual (Wet Chemical)

*WHILE QUANTITIES LAST!

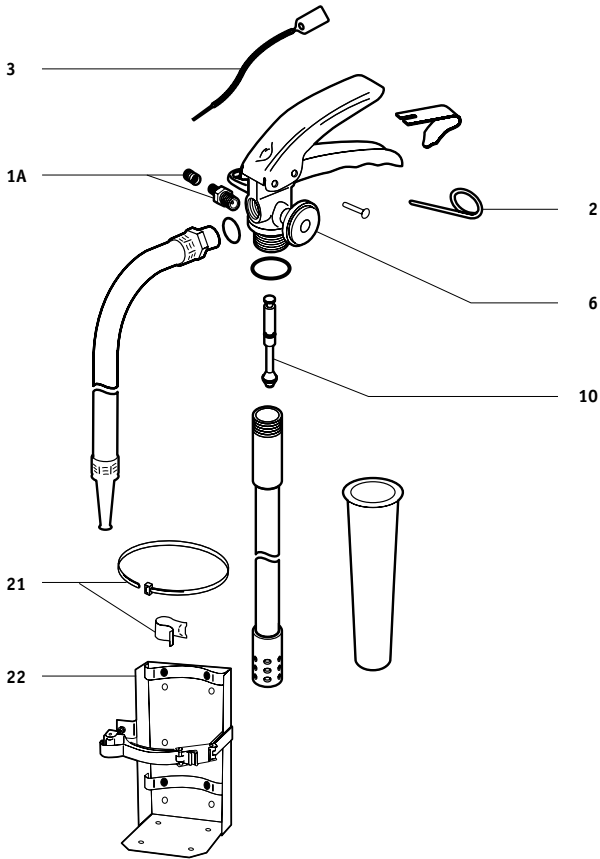

PRX® is a registered mark of Tyco Fire Products LP.

WATER & WET CHEMICAL

W02-1, K01-1, K01-2, K01-3

FIG. P/N SERVICE & MAINTENANCE PART DESCRIPTION

2		Pull Pin, Stainless Steel
3		Tamper Seal
4	430924AS	Lever
5	430250AS	Lever Rivet
6	G100WS	Gauge - 100
7	430273AS	Handle
9	56909AS	Collar O-Ring
10	429099AS	Valve Stem Assembly
12	430004AS	Spring
13	439713AS	Siphon Tube
13	430793AS	Siphon Tube K01-1, K01-2, K01-3
14	439495AS	Hose & Nozzle Assembly W02-1
14	429543AS	Hose & Nozzle Assembly K01-1, K01-2, K01-3
N/S	A430182	PRX Liquid Agent, 6 L K01-1
N/S	A423320	PRX Liquid Agent, 5 gal K01-1
N/S	A79372	Ansulex Chemical Agent, 3 gal K01-2

FIG. P/N ACCESSORY PART DESCRIPTION

1A	AV1	Pressure Valve & Cap Assembly W02-1
N/S	CORE	Pressure Valve Core, Pkg/50 W02-1
N/S	AVC	Pressure Cap, Pkg/50 W02-1
21		Universal Hose Strap/Clip
22	15HB	Heavy-Duty Vehicle Bracket
N/S	WH2	Wall Hanger
N/S	AD24	Recharge Adapter
N/S	429656AS	Service Manual (Wet Chemical) K01-1, K01-2

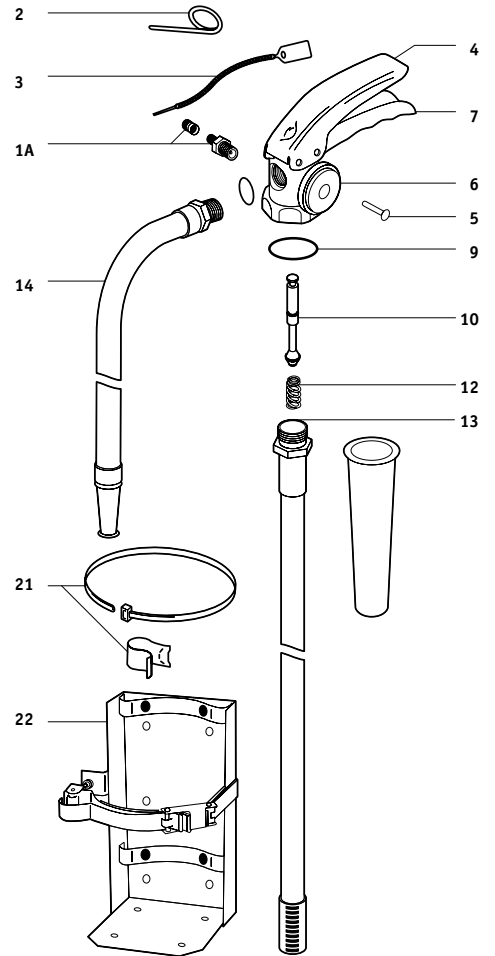

Ansulex® and PRX® are registered marks of Tyco Fire Products LP.

11 ANSUL - FIRE EXTINGUISHER PARTS

CARTRIDGE OPERATED

All 10 - 30 lb E & G Series

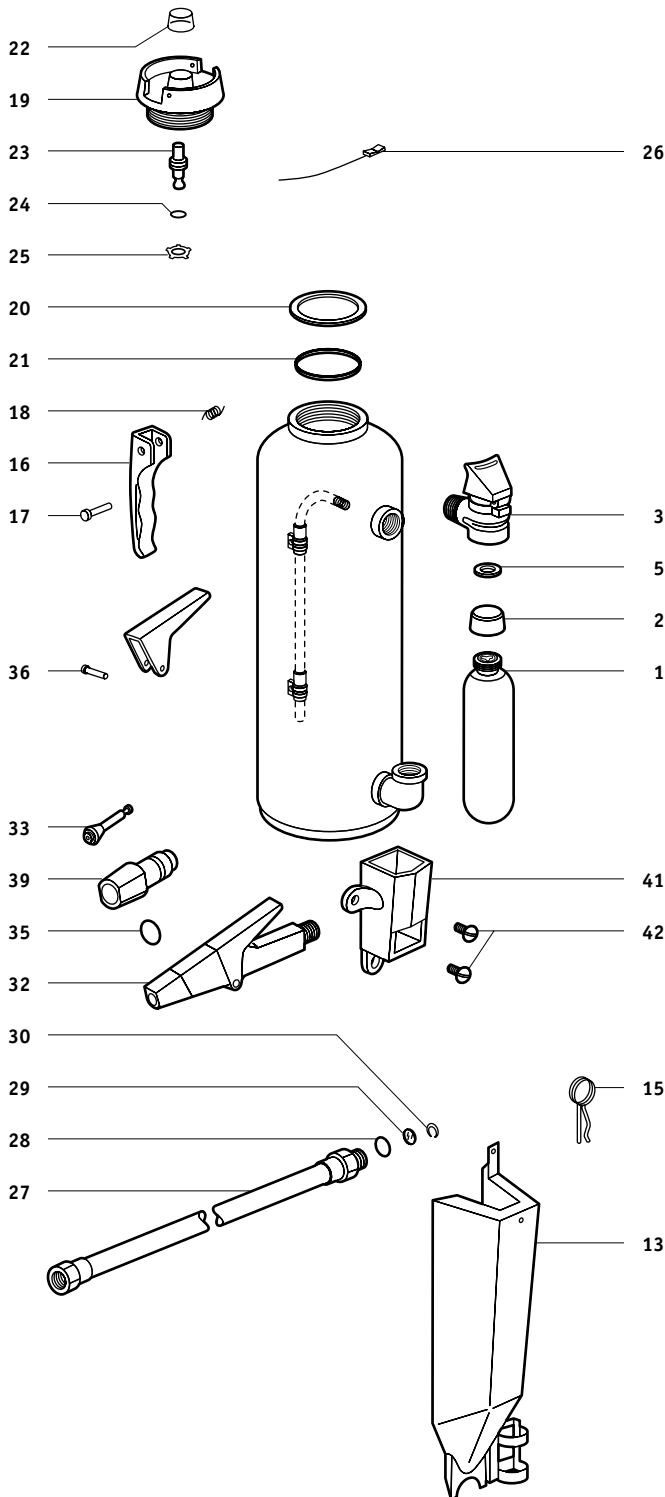

FIG.	P/N	SERVICE & MAINTENANCE PART DESCRIPTION
1	A5373	Cartridge, Nitrogen 30 lb LT, ML
1	A7032	Cartridge, Nitrogen 20 lb LT
1	4616AC	Cartridge, Carbon Dioxide All 10 lb, Except LT
1	4614AC	Cartridge, Carbon Dioxide All 20 lb, Except LT
1	4615AC	Cartridge, Carbon Dioxide All 30 lb, Except LT, ML
2		Cartridge Shipping Cap
3	3626AC	Cartridge Receiver Assembly All, Except CR, LT, ML
5	181AC	Gasket, Cartridge Receiver
13	3652AC	Cartridge Guard Assembly, Metal All 10 lb E Series, Except CR, RP, LT
13	6287AC	Cartridge Guard Assembly, Metal All 30 lb E Series, Except CR, RP, LT
13	6302AC	Cartridge Guard Assembly, Metal All 20 lb E Series, Except CR, RP, LT
13	416346AC	Cartridge Guard Assembly, Plastic All 20 lb G Series, Except RP, LT
13	418025AC	Cartridge Guard Assembly, Plastic All 30 lb G Series, Except RP, LT
15	7066AC	Ring Pin
16	6169AC	Carrying Handle
17	1265AC	Carrying Handle Rivet
18	2902AC	Carrying Handle Spring
19	17999AC	Fill Cap Assembly w/ Indicator
20	6190AC	Gasket, Fill Cap
21	6273AC	Quad Ring, Fill Cap
22	17633AC	Cap, Plastic
23	27648AC	Stem, Indicator
24	17630AC	Quad Ring
25	1239AC	Retaining Ring
26	VIS10	Visual Inspection Seal, Pkg/10
27	7083AC	30 lb Hose Assembly
27	7091AC	20 lb Hose Assembly
27	13005AC	10 lb Hose Assembly
28	6263AC	Hose O-Ring (10 lb)
28	6323AC	Hose O-Ring (20 lb)
28	6324AC	Hose O-Ring (30 lb)
29	415659AC	Hose Seal (10 lb G Series)
29	415660AC	Hose Seal (20 lb E & G Series)
29	415661AC	Hose Seal (30 lb G Series)
30	415855AC	Retaining Ring (10 lb G Series), Pkg/10
30	415856AC	Retaining Ring (20 lb E & G Series), Pkg/10
30	415857AC	Retaining Ring (30 lb G Series), Pkg/10
32	14045AC	Nozzle Assembly 30 lb Regular Dry Chemical
32	14551AC	Nozzle Assembly 20 lb Regular Dry Chemical
32	30778AC	Nozzle Assembly 30 lb ABC, PK
32	30789AC	Nozzle Assembly 20 lb ABC, PK
32	31407AC	Nozzle Assembly 10 lb ABC
33	56117AC	Nozzle Plunger
35	1230AC	O-Ring, Nozzle (w/o O-Ring Groove)
35	3469AC	O-Ring, Nozzle
36	3621AC	Rivet, Nozzle Handle
39	17908AC	Tip, Nozzle Assembly 20 lb Regular Dry Chemical
39	17932AC	Tip, Nozzle Assembly 30 lb Regular Dry Chemical
39	30790AC	Tip, Nozzle Assembly 20 lb ABC, PK
39	30791AC	Tip, Nozzle Assembly 30 lb ABC, PK
41	74206AC	Nozzle Holder Assembly (E Series)
42	14908AC	Nozzle Platform Screw (E Series)
N/S	ACWH1	Hanger Hook
N/S	DCA	Discharge Adapter
N/S	CCW1	Cap Wrench
N/S	13133ACD	Cartridge Receiver Wrench
N/S	AGTSET	Hydrostatic Test Adapter Set
N/S		Vehicle Brackets
N/S	7674AC	Service Manual

CARBON DIOXIDE (w/ Flag Valve)

CD05, CD05A, CD10, CD10A, CD15, CD15A, CD20, CD20A, CD05-1, CD05A-1, CD10-1, CD10A-1, CD15-1, CD15A-1, CD20-1, CD20A-1

FIG.	P/N	SERVICE & MAINTENANCE PART DESCRIPTION
2		Pull Pin, Stainless Steel
3		Tamper Seal
4	441006AS	Lever (Black)
5	429165AS	Lever Rivet
6	429515AS	Safety Disc, Gasket, & Nut Assembly
7	435291AS	Handle (Black)
10	441004AS	Valve Stem Assembly
12	415565AS	Spring (Coil Style)

FIG.	P/N	ACCESSORY PART DESCRIPTION
N/S	RDS15	Band 10, 15 lb Aluminum Cylinder
N/S	RDS20	Band 20 lb Aluminum Cylinder
N/S	RDBACLIP	Horn Clip All 10, 15, 20 lb
N/S	SET6	Hardware Set All 10, 15, 20 lb
N/S	BL209	Replacement Nameplate 5 lb (Non-UL) All 5 lb
N/S	BL210	Replacement Nameplate 10-20 lb (Non-UL) All 10, 15, 20 lb
N/S	WH5	Wall Hanger All 5 lb
N/S	WH15	Wall Hanger All 10, 15 lb
N/S	WH20	Wall Hanger All 20 lb
22	5HB	Heavy-Duty Vehicle Bracket All 5 lb
22	15HB	Heavy-Duty Vehicle Bracket All 10, 15 lb
22	20HB	Heavy-Duty Vehicle Bracket All 20 lb
N/S	429425AS	Service Manual

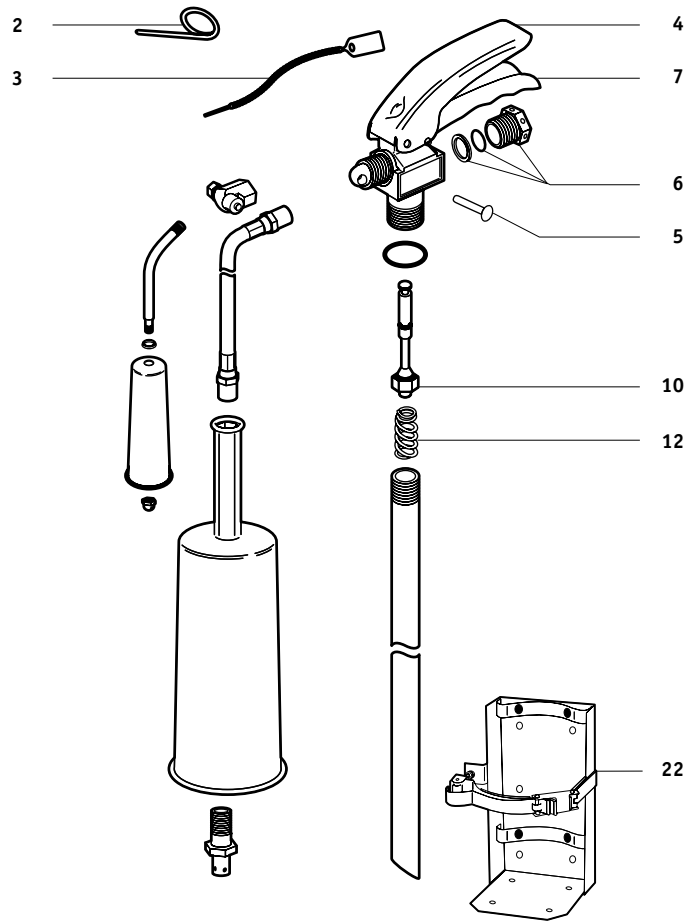

CARTRIDGE OPERATED DRY CHEMICAL

5, A-5, K-5, LR-5, LT-5, LT-A-5, LT-K-5

FIG.	P/N	SERVICE & MAINTENANCE PART DESCRIPTION
1	4523AC	Cartridge All, Except LT
5	181AC	Gasket, Cartridge Receiver
20	615AC	Gasket, Fill Cap
27	15799AC	Hose Assembly w/ Couplings After 1967
28	6263AC	O-Ring
32	6673AC	Nozzle Assembly 5, LT-5

FIG.	P/N	ACCESSORY PART DESCRIPTION
N/S	79758AC	Bracket
2	LHSC	Cartridge Shipping Cap All, Except LT
26	VIS10	Visual Inspection Seal, Pkg/10
N/S	AGTSET	Hydrostatic Test Adapter Set
N/S	HTA13	Hydrostatic Test Adapter (Cylinder Only)

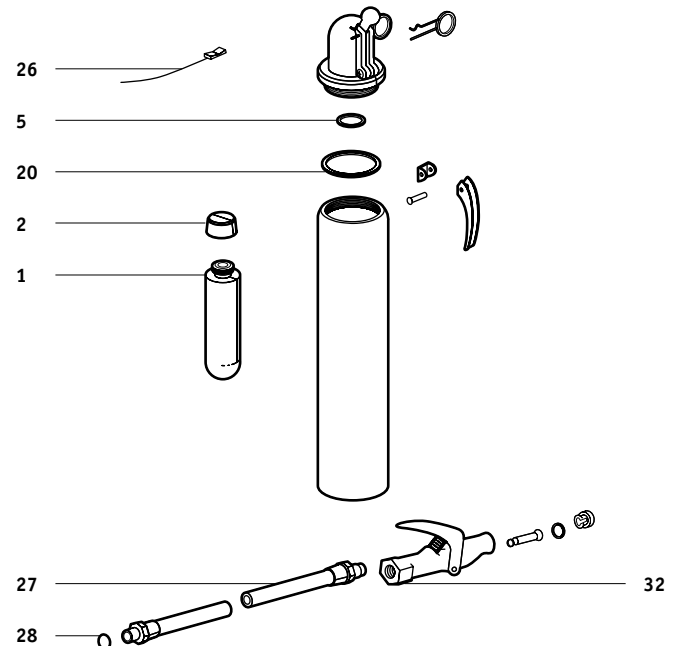

11 ANSUL - FIRE EXTINGUISHER PARTS

CARBON DIOXIDE (w/ R.S. Valve) SY-0571, SY-0572, SY-1071, SY-1072, SY-1571, SY-1572, SY-2071, SY-2072

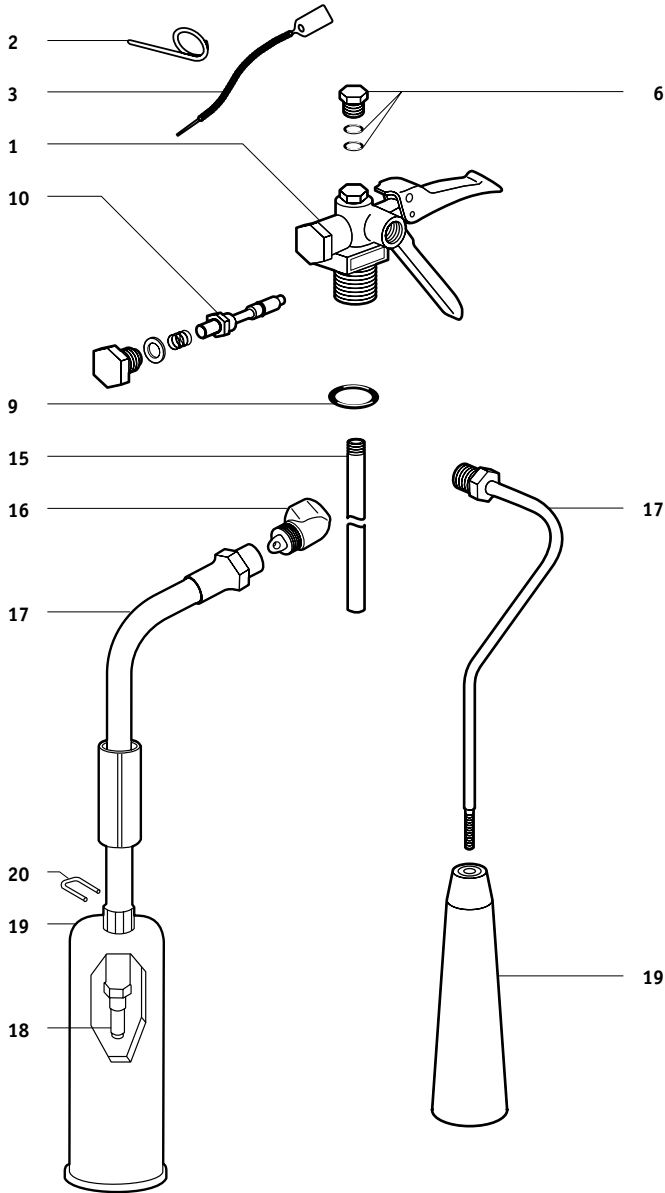
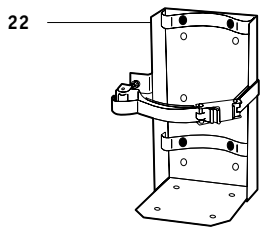

FIG.	P/N	SERVICE & MAINTENANCE PART DESCRIPTION
1	79438AS	Valve Assembly SY-1072, 1572, 2072 (Aluminum Cylinder)
2		Pull Pin, Stainless Steel
3		Tamper Seal
6	RS5	Safety Disc, Gasket, & Nut Assembly
9	79805AS	Collar O-Ring
10	418682AS	Valve Stem Assembly
15	79478AS	Siphon Tube All 15-20 lb
16	79352AS	Elbow All 10, 15, 20 lb
17	73861AS	Discharge Tube Assembly All 5 lb
17	77628AS	Hose Assembly All 10, 15, 20 lb
18	79474AS	Nozzle All 15, 20 lb
19	79350AS	Horn All 5 lb
19	77892AS	Horn w/ Handle All 10, 15 lb
19	77893AS	Horn w/ Handle All 20 lb
20	77894AS	U-Pin All 10, 15, 20 lb

FIG.	P/N	ACCESSORY PART DESCRIPTION
N/S	RDS15	Strap 10-15 lb Aluminum Cylinder
N/S	RDS20	Strap 20 lb Aluminum Cylinder
N/S	RDBACLIP	Horn Clip All 10, 15, 20 lb
N/S	SET6	Hardware Set All 10, 15, 20 lb
N/S	BL209	Replacement Nameplate (Non-U.L.) All 5 lb
N/S	BL210	Replacement Nameplate (Non-U.L.) All 10, 15, 20 lb
N/S	WH5	Wall Hanger All 5 lb
N/S	WH15	Wall Hanger All 10-15 lb
N/S	WH20	Wall Hanger All 20 lb
22	5HB	Heavy-Duty Vehicle Bracket All 5 lb
22	15HB	Heavy-Duty Vehicle Bracket All 10-15 lb
22	20HB	Heavy-Duty Vehicle Bracket



CYLINDER OPERATED WHEELED EXTINGUISHERS

150, 350 lb ("C" Models)

FIG.	P/N	SERVICE & MAINTENANCE PART DESCRIPTION
1	27335AW	Fill Cap, Indicator All, Except Met-L-X, NAX
1A	17633AC	Indicator Cap
1B	27648AC	Indicator Stem
1C	17630AC	Quad Ring
2	3461AW	Gasket
5	Z78705AWD	Valve (Special Order)
8	423581AW	Nitrogen Hose Assembly (Valve to Regulator)
N/S	8750AW	Low Pressure Hose (Regulator to Tank) 150-350 lb (1969-1973)
9	14236AW	Hose Visual Inspection Disc, Strips of 6 ea 150 lb
9	14237AW	Hose Visual Inspection Disc, Strips of 5 ea 350 lb
10	670AW	Gasket 150 lb
10	8105AW	Gasket 350 lb
11	960AWD	Hose, 3/4" x 50', Special Order 150 lb, Except LT
12A	8101AWD	Ball Valve 150 lb, Except Met-L-X, NAX
12C	11112AW	Gasket, Valve To Hose 150 lb
12D	8105AW	Gasket, Nozzle All, Except LR
12E	12703AW	Nozzle Tip 150 lb, Except Met-L-X, NAX
12E	12707AW	Nozzle Tip 350 lb, Except Met-L-X, NAX
12F	29507AWD	Body, Nozzle All, Except LR
N/S	79012AW	Service Manual
N/S	53141AW	Regulator Test Manual

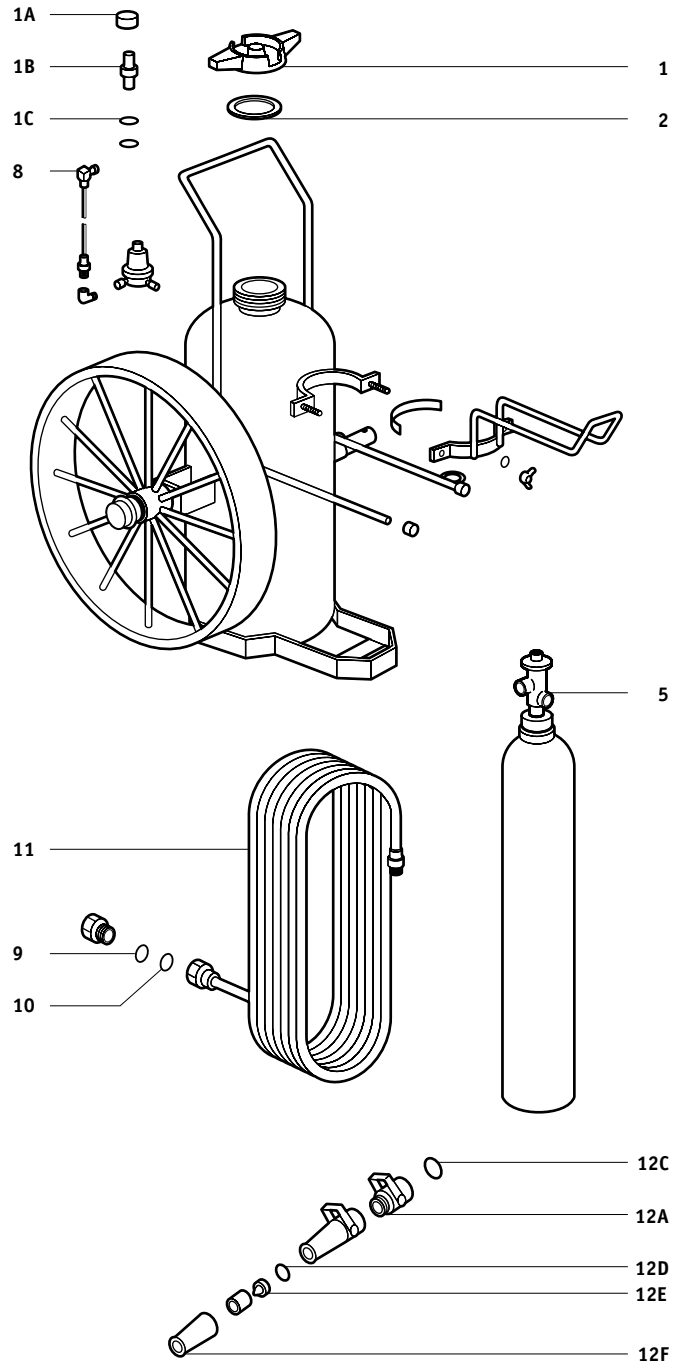

11 BADGER - FIRE EXTINGUISHER PARTS

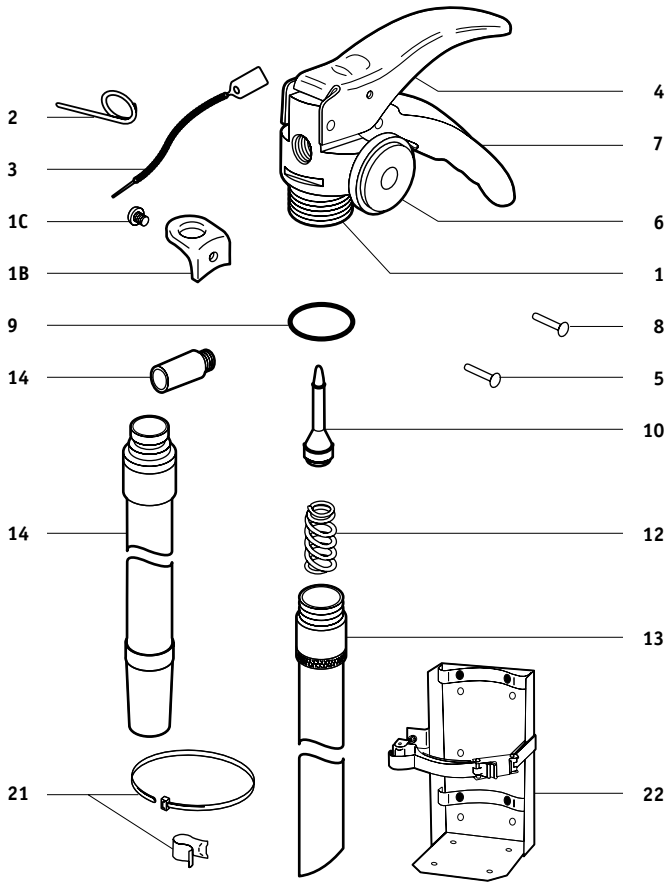

DRY CHEMICAL ADV-250, ADV-550, ADV-10, ADV-20

FIG.	P/N	SERVICE & MAINTENANCE PART DESCRIPTION
1	21008376B	Valve Assembly 2.5 lb Model
7	21008377B	Valve Assembly 5.5, 10, 20 lb Model
1B	8516B	Hanger Loop
10C	19622B	Hanger Loop Screw
2		Pull Pin
N/S	23535B	Chain (Nylon) for Pull Pin
3		Tamper Seal
4	21007875B	Lever
8	320750B	Lever Rivet
6	G100	Gauge - 100 2.5 lb Model
6	G195	Gauge - 195 5.5, 10, 20 lb Model
7	21007873B	Handle 2.5, 5.5 lb Model
7	21007874B	Handle 10, 20 lb Model
8	320751B	Handle Rivet
9	340035K	Neck Seal
10	440068K	Valve Stem
12	322063B	Spring
13	21007861B	Siphon Tube Assembly 2.5 lb Model
13	21007862B	Siphon Tube Assembly 5.5 lb Model
13	21007863B	Siphon Tube Assembly 10 lb Model
13	21007864B	Siphon Tube Assembly 20 lb Model
N/S	320167K	Siphon Tube O-Ring
14	21005805B	Nozzle 2.5 lb Model
14	21006335B	Hose & Nozzle Assembly 5.5 lb Model
14	21007908B	Hose & Nozzle Assembly 10 lb Model
14	21006338B	Hose & Nozzle Assembly 20 lb Model

FIG.	P/N	ACCESSORY PART DESCRIPTION
21		Universal Hose Strap/Clip
22	466401K	Heavy-Duty Vehicle Bracket 2.5 lb Model
22	5DC	Heavy-Duty Vehicle Bracket 5.5 lb Model
22	5HB	Heavy-Duty Vehicle Bracket 10 lb Model
22	15HB	Heavy-Duty Vehicle Bracket 20 lb Model
N/S	1141K	Wall Hook 2.5 lb Model
N/S	WH5	Wall Hook 5.5 & 10 lb Model
N/S	14260K	Wall Hook 20 lb Model
N/S	AD23	Recharge Adapter
N/S	HTA18	Hydrostatic Test Adapter

DRY CHEMICAL

275RB-1, 250MB-1, 5RB-4H, 5MB-4H, 5MB-5H, 5MB-6H, 5MB-7H, 5MB-8H, 6MB-4H, 10MB-3H, 10MB-4H, 10MB-8H

HALON 1211

2.5-1211B, 5-1211B, 9-1211B-S, 9-1211B-T

HALOTRON I

2.5HB, 5HB

FIG.	P/N	SERVICE & MAINTENANCE PART DESCRIPTION
1	19824B	Valve Assembly 5MB-5H, 5MB-6H, 5MB-7H, 5MB-8H
1	19520B	Valve Body
1B	8516B	Hanger Loop All, Except 275RB-1, 250MB-1, 2.5-1211B
1C	19622B	Hanger Loop Screw All, Except 275RB-1, 250MB-1, 2.5-1211B
2		Pull Pin
3		Tamper Seal
4	18363B	Lever
5	18404B	Lever Rivet
6	G195	Gauge - 195 All Dry Chemical
6	G125H	Gauge - 125 (Halon) 2.5-1211B, 5-1211B
6	G195H	Gauge - 195 (Halon) 9-1211B-S, 9-1211B-T
6	G100T	Gauge - 100 (Halotron I) All Halotron I
7	18361B	Handle
8	16517B	Handle Rivet
9	20745B	Collar O-Ring All Dry Chemical, Halon
9	23074B	Collar O-Ring All Halotron I
10	18672B	Valve Stem All Halon
10	19010B	Valve Stem All Dry Chemical
10	23068B	Valve Stem All Halotron I
12	19393B	Spring 5MB-5H, 5MB-6H, 5MB-7H, 5MB-8H, 6MB-4H, 10MB-3H, 2.5HB, 5HB
13	19825B	Siphon Tube 5MB-5H, 5MB-6H, 5MB-7H, 5MB-8H
14	14816B	Nozzle 250MB-1
14	22363B	Hose & Nozzle Assembly 10MB-4H, 10MB-8H
14	19548B	Hose & Nozzle Assembly 5MB-4H, 5MB-5H
14	21028B	Hose & Nozzle Assembly 5MB-6H, 5MB-8H

FIG.	P/N	ACCESSORY PART DESCRIPTION
21		Universal Hose Strap/Clip All, Except 250MB-1, 275RB-1, 2.5-1211B
N/S	WH5	Wall Hanger All 5-10 lb, Except 10MB-3H, 9-1211B-S
N/S	WH15	Wall Hanger 10MB-3H, 9-1211B-S
N/S	MB250	Vehicle Bracket 250MB-1, 275RB-1, 2.5-1211B
N/S	MB5	Vehicle Bracket 5-6 lb
22	5DC	Heavy-Duty Vehicle Bracket 5-6 lb
22	5HB	Heavy-Duty Vehicle Bracket 10MB-4H, 10MB-8H, 10RB-7H, 9-1211B-T
22	10HB	Heavy-Duty Vehicle Bracket 10MB-3H, 9-1211B-S
N/S	AD21	Recharge Adapter
N/S	HTA45	Hydrostatic Test Adapter

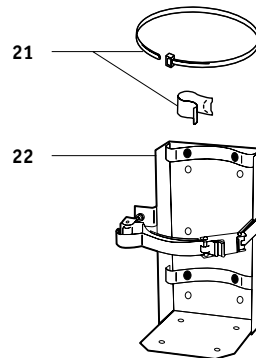
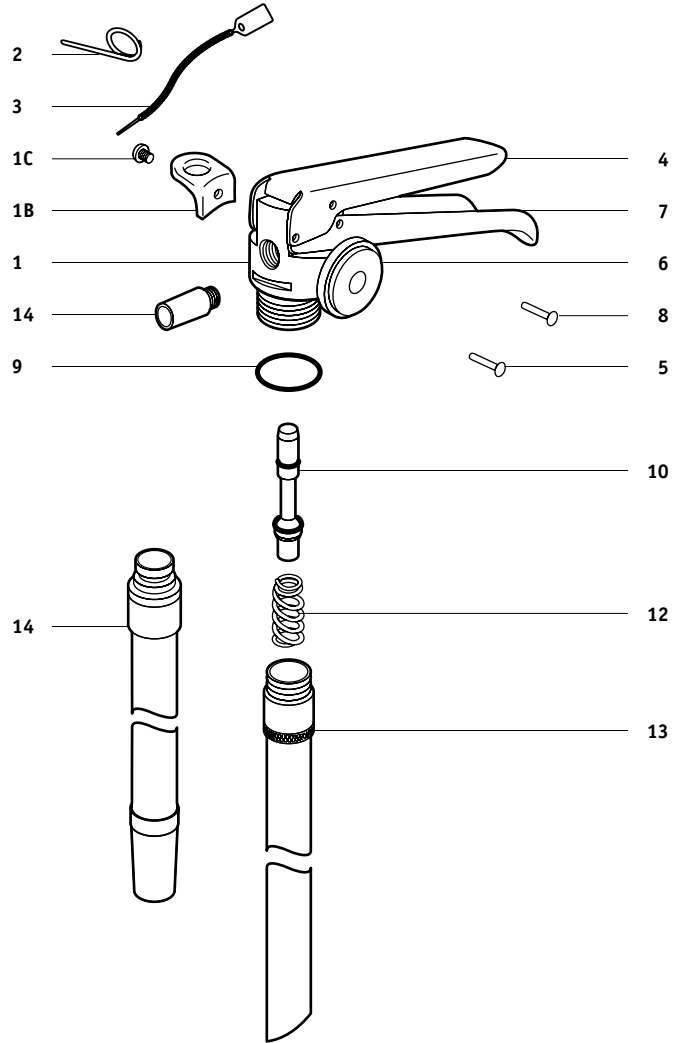

11 BADGER - FIRE EXTINGUISHER PARTS

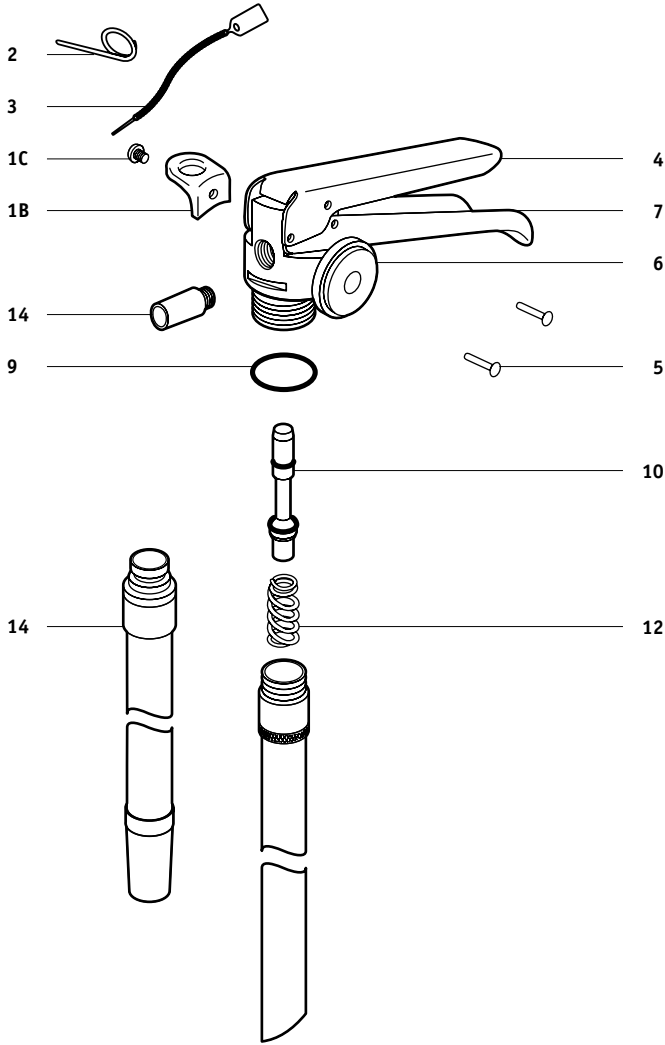

DRY CHEMICAL

B250M, B275BC, B250P, B5M, B5M1, B5BC, B5P, B10M, B10BC1, B10P1

HALOTRON I

2.5HB-1, 2.5HB-2, 5HB-1, 5HB-2

FIG. P/N SERVICE & MAINTENANCE PART DESCRIPTION

1B	23358B	Hanger Loop
1C	21390B	Hanger Loop Screw
2		Pull Pin
3		Tamper Seal
4	23351B	Lever
5	23352B	Lever Rivet
6	G195	Gauge - 195 All Dry Chemical
6	G100T	Gauge - 100 (Halotron I) All Halotron I
7	23353B	Handle
9	20745B	Collar O-Ring All Dry Chemical
9	23074B	Collar O-Ring All Halotron I
10	23389B	Valve Stem All Dry Chemical
10	23355B	Valve Stem Assembly All Halotron I
12	19393B	Spring
14	23393B	Hose & Nozzle Assembly B5M, B5M1
14	23399B	Hose & Nozzle Assembly B10M

FIG. P/N ACCESSORY PART DESCRIPTION

21		Universal Hose Strap All 5, 10 lb
N/S	WH5	Wall Hanger All 5, 10 lb
N/S	MB250	Vehicle Bracket All 2.5 lb
N/S	MB5	Vehicle Bracket All 5 lb
22	5DC	Heavy-Duty Vehicle Bracket All 5 lb
22	5HB	Heavy-Duty Vehicle Bracket All 10 lb
N/S	AD21	Recharge Adapter
N/S	HTA45	Hydrostatic Test Adapter

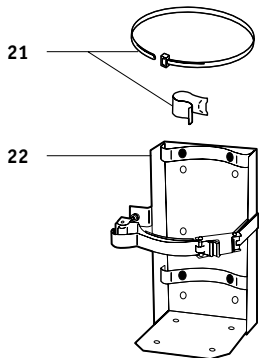

DRY CHEMICAL

5RB-2, 6MB-1, 10MB-1H, 10MB-2H, 10RB-2H, 10PB-2H, 20MB-1H, 20RB-1H, 20PB-1H, 20MB-2H, 20PB-2H, 20MB-6H, 20RB-7H

HALON 1211

13-1211B-S, 13-1211B-T, 17-1211B, 20-1211B

FIG. P/N SERVICE & MAINTENANCE PART DESCRIPTION

1A	16459B	Valve Body
1B	8516B	Hanger Loop
1C	19622B	Hanger Loop Screw
2		Pull Pin
3		Tamper Seal
4	16438B	Lever
5	16518B	Lever Rivet
6	G195	Gauge - 195 Dry Chemical
6	G195H	Gauge - 195 (Halon)
7	16513B	Handle
8	16517B	Handle Rivet
9	20746B	Collar O-Ring
10	12426B	Valve Stem Assembly Dry Chemical
12	7630B	Spring
14	20580B	Hose & Nozzle Assembly 20MB-2H, 20MB-6H

FIG. P/N ACCESSORY PART DESCRIPTION

21	WH5	Universal Hose Strap/Clip
N/S	WH5	Wall Hanger
N/S	WH15	Wall Hanger 10 lb Dry Chemical, 13-1211B-T
N/S	WH20	Wall Hanger 13-1211B-S
N/S	MB5	Vehicle Bracket 20 lb Dry Chemical, 17-1211B, 20-1211B
22	5DC	Heavy-Duty Vehicle Bracket 5 lb
22	5HB	Heavy-Duty Vehicle Bracket 5-6 lb
22	10HB	Heavy-Duty Vehicle Bracket 10 lb Dry Chemical, 13-1211B-T
22	15HB	Heavy-Duty Vehicle Bracket 13-1211B-S
22	15HB	Heavy-Duty Vehicle Bracket 20 lb Dry Chemical, 17-1211B, 20-1211B
N/S	AD24	Recharge Adapter
N/S	HTA44	Hydrostatic Test Adapter

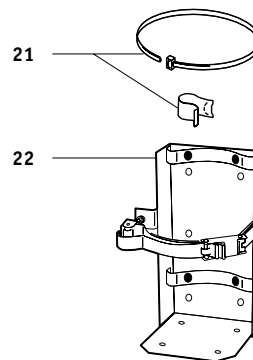
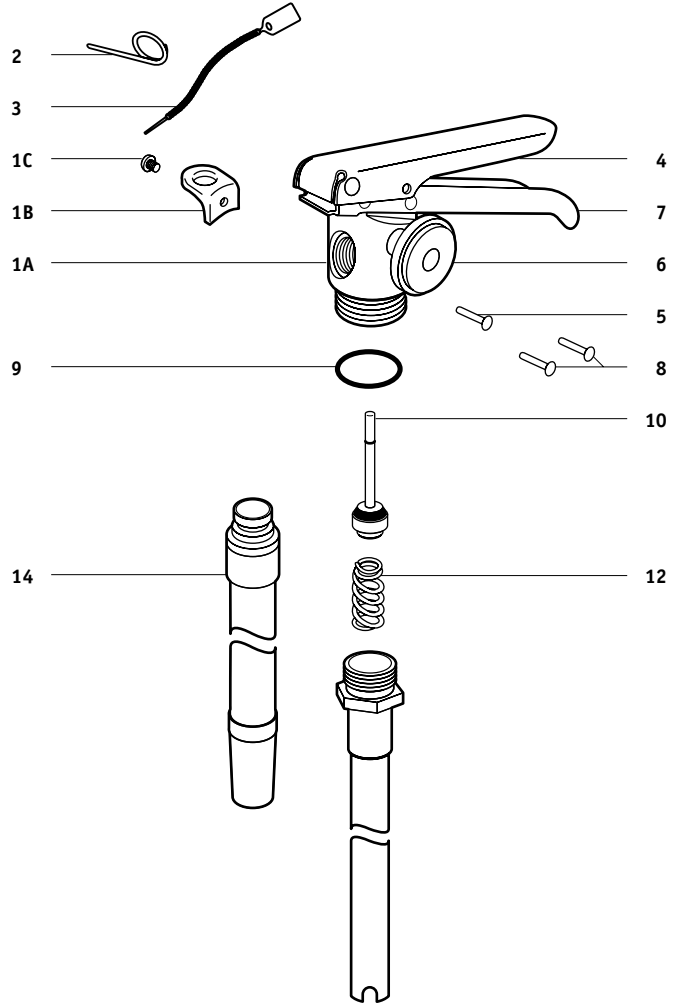

11 BADGER - FIRE EXTINGUISHER PARTS

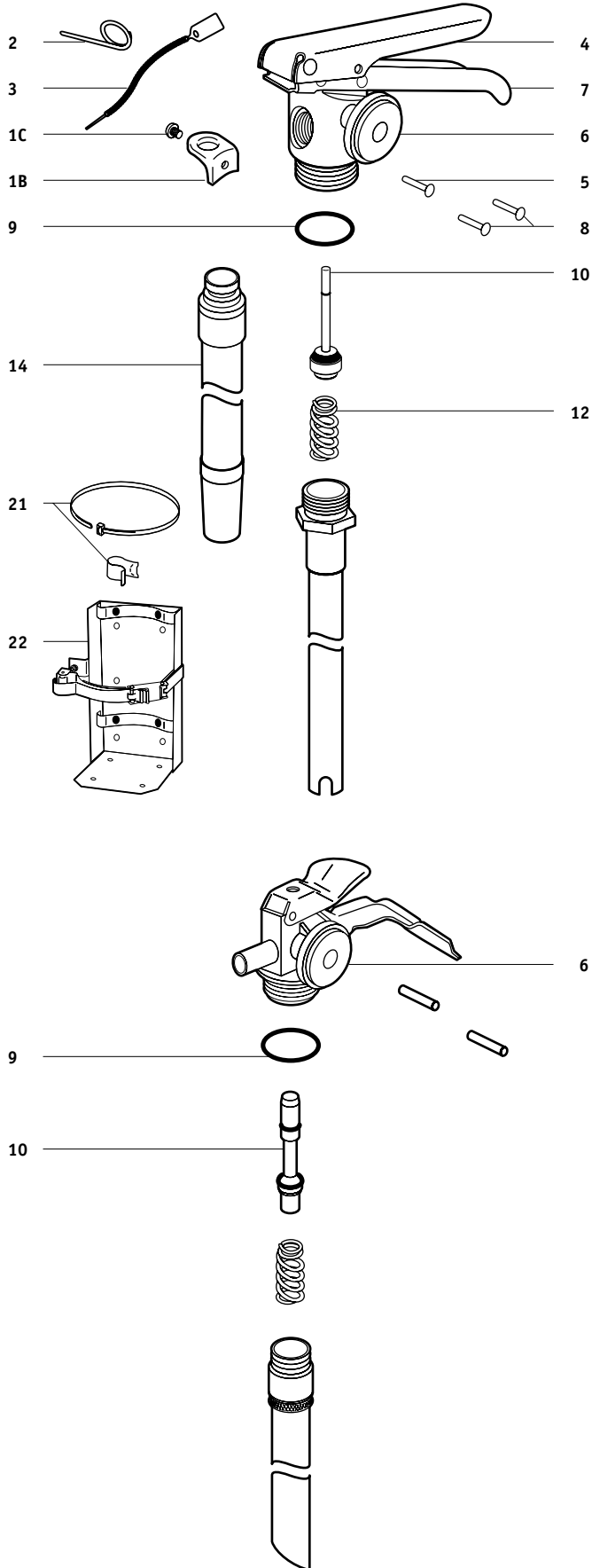

DRY CHEMICAL

10MB-5H, 10MB-9H, 10RB-3H, 10PB-9H, 10RB-6H, 20MB-3H, 20RB-2H, 20PB-3H, 20MB-5H, 20RB-4H, B10M1, B20M, B20BC, B20P, B10M1-HF, B10P1-HF, B20M-HF, B20P-HF

HALOTRON I

11HB, 11HB-1, 15.5HB-1, 15.5HB

FIG. P/N SERVICE & MAINTENANCE PART DESCRIPTION

1B	23358B	Hanger Loop
1C	21390B	Hanger Loop Screw
2		Pull Pin, Stainless Steel
3		Tamper Seal
4	16438B	Lever
5	16633B	Lever Rivet
6	G195	Gauge - 195 All Dry Chemical
6	G125T	Gauge - 125 (Halotron I) All Halotron I
7	16437B	Handle
8	23354B	Handle Rivet
9	20746B	Collar O-Ring All Dry Chemical
9	23089B	Collar O-Ring All Halotron I
10	12426B	Valve Stem Assembly All Dry Chemical
10	23086B	Valve Stem Assembly All Halotron I
12	7630B	Spring
14	21407B	Hose & Nozzle Assembly 20MB-3H, 20MB-5H
14	22601B	Hose & Nozzle Assembly 10MB-9H, B10M1
14	21006168B	Hose & Nozzle Assembly All High Flow (HF) Models

FIG. P/N ACCESSORY PART DESCRIPTION

21		Universal Hose Strap/Clip
N/S	WH5	Wall Hanger 10 lb
N/S	WH20	Wall Hanger 20 lb
22	5HB	Heavy-Duty Vehicle Bracket 10 lb
22	15HB	Heavy-Duty Vehicle Bracket 20 lb
N/S	AD24	Recharge Adapter
N/S	HTA44	Hydrostatic Test Adapter

DRY CHEMICAL

P200RA, P275RA, P250MA

HALON 1211

P1.25-1211A, P2.5-1211A

FIG. P/N SERVICE & MAINTENANCE PART DESCRIPTION

6	G100	Gauge - 100 P200RA
6	G195	Gauge - 195 P275RA, P250MA
6	G100H	Gauge - 100 (Halon) P1.25-1211A
6	G125H	Gauge - 125 (Halon) P2.5-1211A
9	20745B	Collar O-Ring
10	19010B	Valve Stem Assembly All Dry Chemical
10	18672B	Valve Stem Assembly All Halon

FIG. P/N ACCESSORY PART DESCRIPTION

N/S	AD21	Recharge Adapter P275RA, P250MA, P2.5-1211A
N/S	HTA45	Hydrostatic Test Adapter

DRY CHEMICAL

B-10-RG, B-10-RG-LT, B-10-PK, B-10-PK-LT, B-10-PK-HF, B-10-A, B-10-A-LT, B-10-A-HF, B-20-RG, B-20-RG-LT, B-20-PK, B-20-PK-LT, B-20-PK-HF, B-20-PK-HF-LT, B-20-A, B-20-A-LT, B-20-A-HF, B-20-A-HF-LT, B-30-RG, B-30-RG-LT, B-30-PK, B-30-PK-LT, B-30-PK-HF, B-30-PK-HF-LT, B-30-A, B-30-A-LT, B-30-A-HF, B-30-A-HF-LT

FIG P/N SERVICE & MAINTENANCE PART DESCRIPTION

1	21009612BC	Cartridge All 10 lb, Except LT
1	21009613BC	Cartridge All 20 lb, Except LT
1	21009614BC	Cartridge All 30 lb, Except LT
3	440384BC	Cartridge Receiver Assembly
5	320934BC	Gasket, Cartridge Receiver
13	21009967BC	Cartridge Guard Assembly All 10 lb
13	440324BC	Cartridge Guard Assembly All 20, 30 lb
15	320911BC	Ring Pin
16	23678BC	Carrying Handle
17	320837BC	Carrying Handle Rivet
18	320838BC	Carrying Handle Spring
19	440314BC	Fill Cap Assembly w/ Indicator
20	320779BC	Gasket, Fill Cap
21	320780BC	Quad Ring, Fill Cap
22	340744BC	Cap, Plastic
24	320769BC	Quad Ring
25	320778BC	Retaining Ring
27	440332BC	10 lb Hose Assembly
27	440333BC	20 lb Hose Assembly
27	440334BC	30 lb Hose Assembly
28	320914K	Hose O-Ring
31	320905BC	Nozzle O-Ring
32	440360BC	Nozzle Assembly (Less Tip)
35	320958BC	Pin, Nozzle
39	341010BC	Nozzle Tip 20 lb ABC
39	341016BC	Nozzle Tip 30 lb ABC
39	341017BC	Nozzle Tip 30 lb Regular Dry Chemical
41	320928BC	Nozzle Holster All 20, 30 lb
42	320929BC	Nozzle Holster Screw

FIG P/N ACCESSORY PART DESCRIPTION

26	VIS10	Visual Inspection Seal
2	LHSC	Cartridge Shipping Cap
N/S	ACWH1	Hanger Hook
N/S	DCA	Discharge Adapter

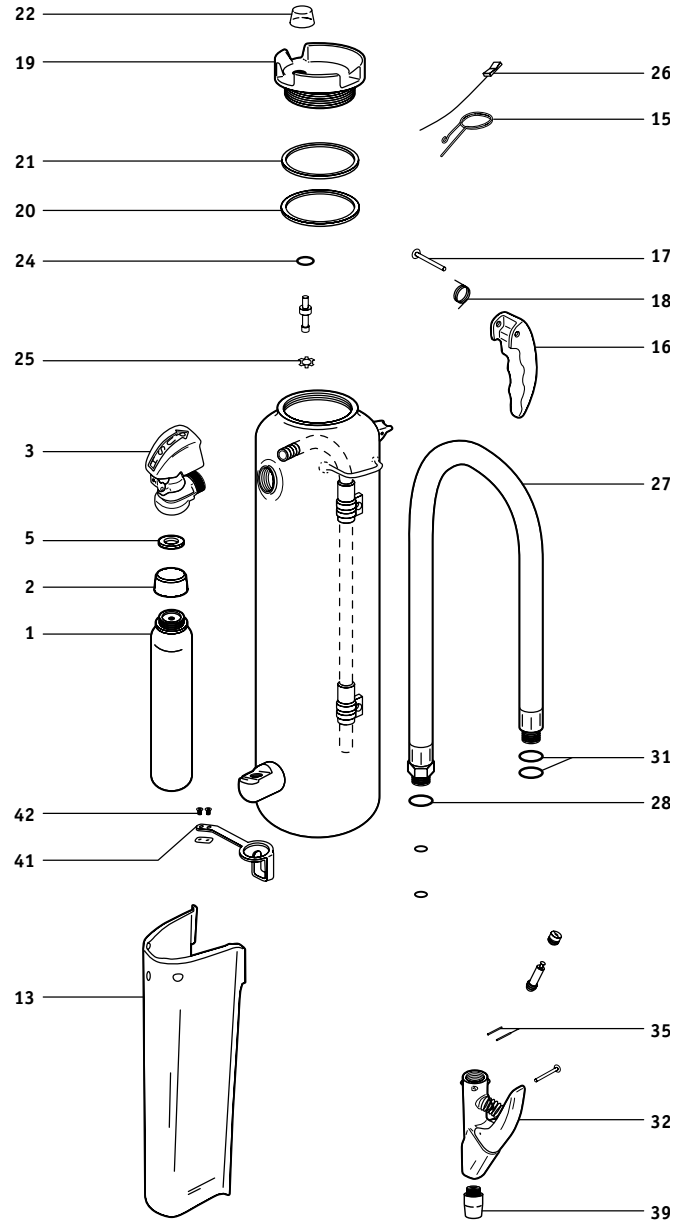

11 BADGER - FIRE EXTINGUISHER PARTS

CARBON DIOXIDE

B5H-1, B5H-1A, B10H-2, B10HA, B15H-2, B15HA, B20H-2, B20HA

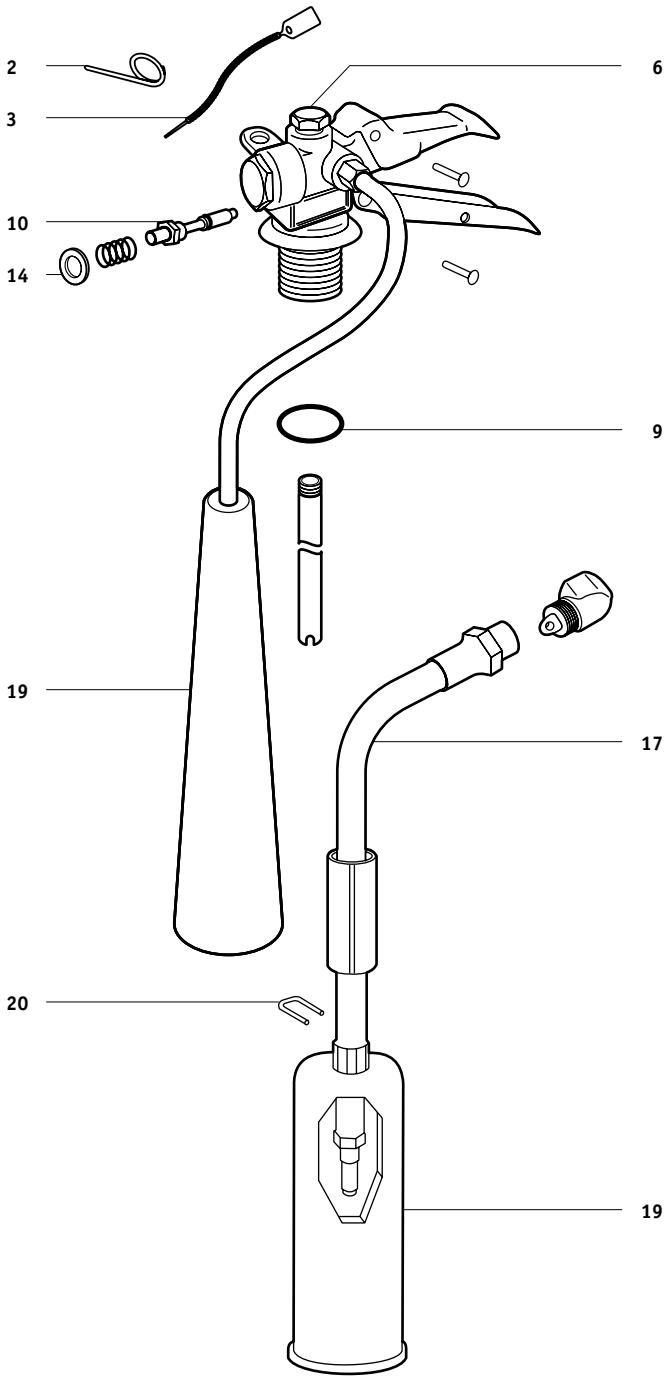
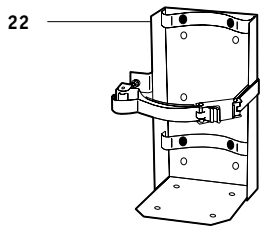

FIG.	P/N	SERVICE & MAINTENANCE PART DESCRIPTION
2		Pull Pin, Stainless Steel
3		Tamper Seal
6	24643B	Safety Disc, Gasket, & Nut Assembly
9	16464B	Collar O-Ring B5H-1A, B10HA, B15HA, B20HA
10	5558B	Valve Stem Assembly
14	3524B	Retainer Washer
17	23005B	Hose & Nozzle Assembly (.110) 10 lb
17	23010B	Hose & Nozzle Assembly (.099) 15-20 lb
19	1840B	Horn w/ Handle All 10 lb
19	1841B	Horn w/ Handle All 15-20 lb
20	1838B	U-Pin All 10, 15, 20 lb

FIG.	P/N	ACCESSORY PART DESCRIPTION
N/S	RDBACLIP	Horn Clip All 10, 15, 20 lb
N/S	RDS15	Strap B10HA, B15HA
N/S	RDS20	Strap B20HA
N/S	SET6	Hardware Set 10-20 lb Aluminum Cylinder
N/S	BL209	Replacement Nameplate (Non-UL) All 5 lb
N/S	BL210	Replacement Nameplate (Non-UL) All 10, 15, 20 lb
N/S	WH5	Wall Hanger All 5 lb
N/S	WH15	Wall Hanger All 10, 15 lb
N/S	WH20	Wall Hanger All 20 lb
22	5HB	Heavy-Duty Vehicle Bracket All 5 lb
22	15HB	Heavy-Duty Vehicle Bracket All 10, 15 lb
22	20HB	Heavy-Duty Vehicle Bracket All 20 lb



CARBON DIOXIDE

B5V, B10V, B15V, B20V

FIG. P/N SERVICE & MAINTENANCE PART DESCRIPTION

2		Pull Pin, Stainless Steel
3		Tamper Seal
4	16438B	Lever
5	16633B	Lever Rivet
6	24643B	Safety Disc, Gasket, & Nut Assembly
7	16437B	Handle
8	23354B	Handle Rivet
9	16464B	Collar O-Ring
10	20981B	Valve Stem Assembly
16	20991B	Elbow Assembly B10V, B15V, B20V
16A	21101B	O-Ring for Elbow
16B	3524B	Washer for Elbow
17	21116B	Discharge Tube B5V
17	23005B	Hose & Nozzle Assembly (.110) B10V
17	23010B	Hose & Nozzle Assembly (.099) B15V, B20V
19	8886B	Horn B5V
19	1840B	Horn w/ Handle B10V
19	1841B	Horn w/ Handle B15V, B20V
20	1838B	U-Pin B10V, B15V, B20V

FIG. P/N ACCESSORY PART DESCRIPTION

N/S	RDS15	Strap B10V, B15V
N/S	RDS20	Strap B20V
N/S	RDBACLIP	Horn Clip B10V, B15V, B20V
N/S	SET6	Hardware Set B10V, B15V, B20V
N/S	BL209	Replacement Nameplate (Non-UL) B5V
N/S	BL210	Replacement Nameplate (Non-UL) B10V, B15V, B20V
N/S	WH5	Wall Hanger B5V
N/S	WH15	Wall Hanger B10V, B15V
N/S	WH20	Wall Hanger B20V
22	5HB	Heavy-Duty Vehicle Bracket B5V
22	15HB	Heavy-Duty Vehicle Bracket B10V, B15V
22	20HB	Heavy-Duty Vehicle Bracket B20V

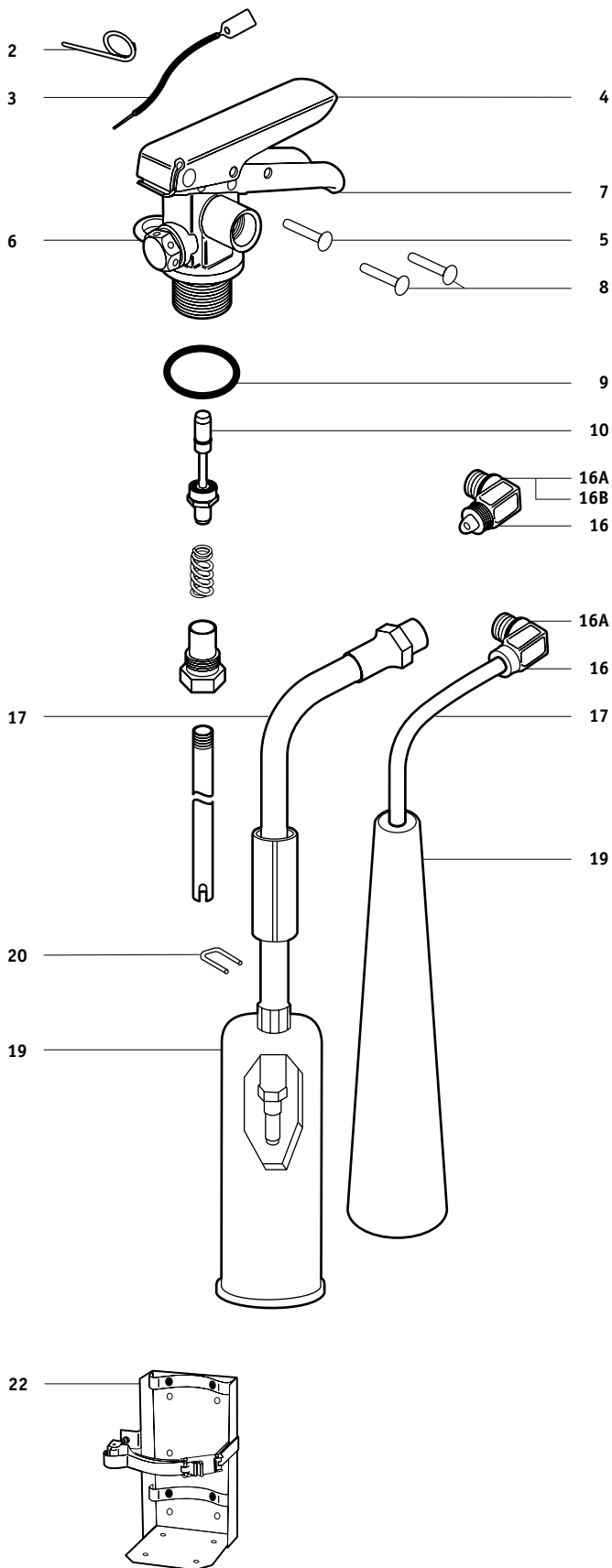

11 BADGER - FIRE EXTINGUISHER PARTS

WATER/LOADED STREAM

WP61, PWA-61

WET CHEMICAL

WC-10, WC-25, WC-100, WC-250

AR-AFFF FOAM

F-100, F-250

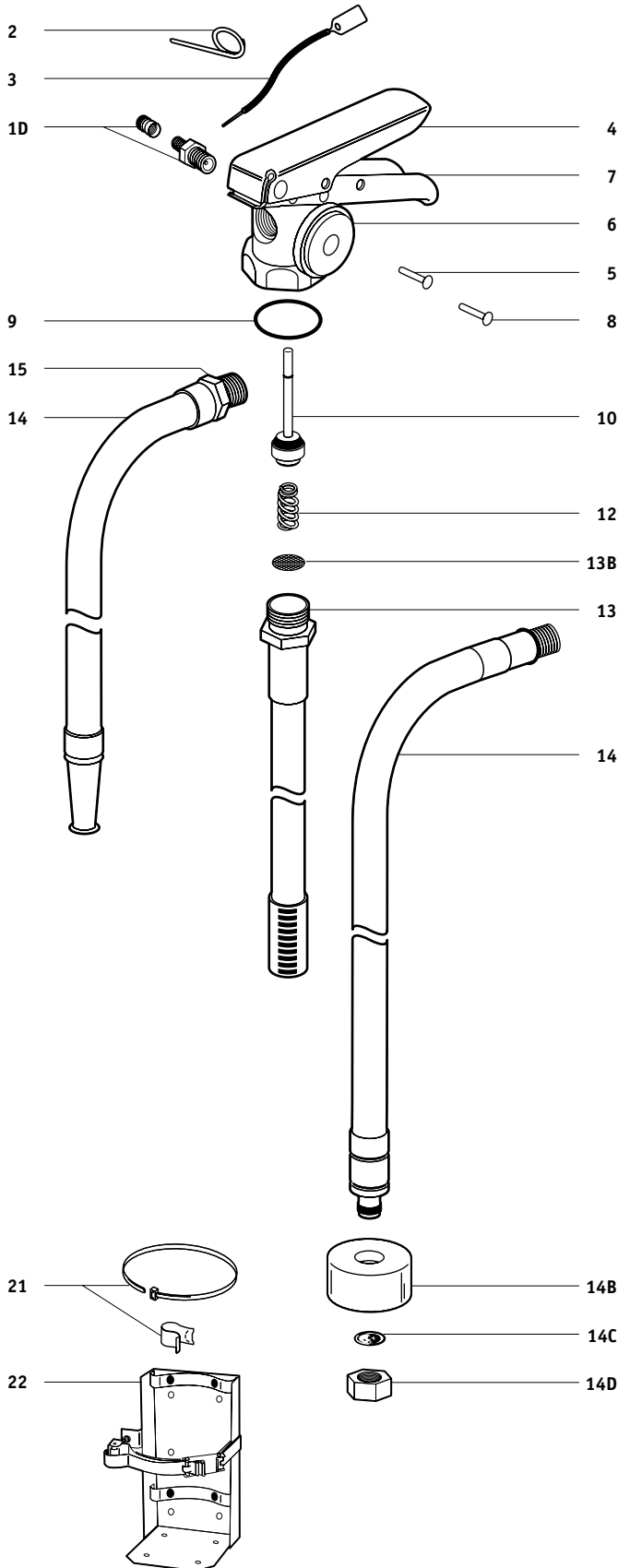

FIG.	P/N	SERVICE & MAINTENANCE PART DESCRIPTION
2		Pull Pin, Stainless Steel
3		Tamper Seal
4	16438B	Lever
5	16633B	Lever Rivet
6	G100WS	Gauge - 100
7	16437B	Handle
8	23354B	Handle Rivet
9	20746B	Collar O-Ring
10	12426B	Valve Stem Assembly
12	7630B	Spring
13	14992B	Siphon Tube Assembly WP61, PWA-61, WC-25, WC-250
13	21539B	Siphon Tube Assembly WC-10, WC-100
13B	22445B	Screen Disk For Siphon Tube (WC-10, WC-25, WC-100, WC-250)
14	8844B	Hose & Nozzle Assembly WP61, PWA-61
14	23161B	Hose Assembly w/ Tip (Replaces 22338) WC-10, WC-25, WC-100, WC-250
14B	23162B	Finger Guard WC-10, WC-25, WC-100, WC-250
14C	KR97054	Foil Inspection Disc, Pkg/10 WC-10, WC-25, WC-100, WC-250
14D	KR97290	Nozzle Tip Cap, Pkg/10 WC-10, WC-25, WC-100, WC-250
N/S	AC100	Wet Chemical Recharge, 6 L WC-100
N/S	AC250	Wet Chemical Recharge, 2.5 gal WC-250

FIG.	P/N	ACCESSORY PART DESCRIPTION
1D	AV1*	Pressure Valve & Cap Assembly
N/S	CORE*	Pressure Valve Core, Pkg/50
N/S	AVC*	Pressure Cap, Pkg/50
21		Universal Hose Strap/Clip WC-10, WC-25, WC-100, WC-250, F-100, F-250
N/S	792B	Loaded Stream Anti-Freeze Charge PWA-61
N/S	WH2	Wall Hanger
22	15HB	Heavy-Duty Vehicle Bracket
N/S	AD24	Recharge Adapter WP61, PWA-61, WC-100, WC-250, F-100, F-250
N/S	HTA10	Hydrostatic Test Adapter

*WP61 & PWA-61 (up to 2002)

STORED PRESSURE DRY CHEMICAL WHEELED

50RB, 50MB, 50PB

HALON WHEELED

50-1211B

FIG.	P/N	SERVICE & MAINTENANCE PART DESCRIPTION
1	Z20135BD	Valve Assembly (Special Order) <i>Dry Chemical</i>
2		Pull Pin, Stainless Steel
3		Tamper Seal
6	G240	Gauge - 240 <i>Dry Chemical</i>
9	20746B	Collar O-Ring
10	12426B	Valve Stem Assembly <i>Dry Chemical</i>
12	7630B	Spring
14	Z20131BD	Hose, 1/2" x 25' (Special Order)
14A	Z440360BD	Nozzle Assembly (Less Tip) (Special Order)
14B	Z20133BD	Nozzle Tip (Special Order) 50MB

FIG.	P/N	ACCESSORY PART DESCRIPTION
N/S	6160A	Recharge Adapter
N/S	HTA44	Hydrostatic Test Adapter

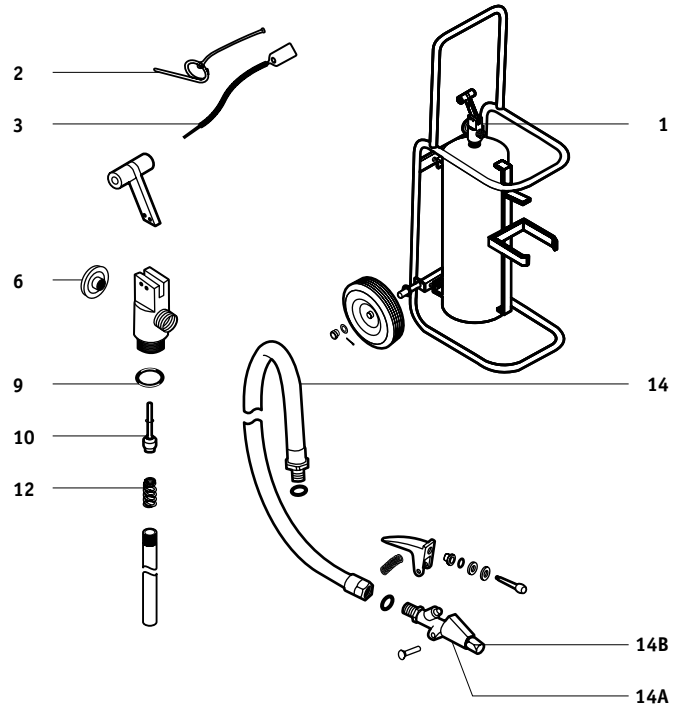

STORED PRESSURE DRY CHEMICAL WHEELED

150RB, 150MB, 150PB

HALON WHEELED

150-1211B

FIG.	P/N	SERVICE & MAINTENANCE PART DESCRIPTION
2		Pull Pin, Stainless Steel
3		Tamper Seal
6	G240	Gauge - 240 <i>Dry Chemical</i>
9	20510B	Collar O-Ring
10	23658BD	Valve Stem Assembly (Special Order)
14	20079BD	Hose, 3/4" x 50' (Special Order)
14A	Z23123BD	Nozzle Assembly (Less Orifice) (Special Order) <i>Dry Chemical</i>
14D	Z23446BD	Nozzle Orifice (Special Order) 150RB
14D	Z23447BD	Nozzle Orifice (Special Order) 150MB
N/S	Z20556BD	Swivel (Special Order)
15	4045B	Washer

FIG.	P/N	ACCESSORY PART DESCRIPTION
N/S	5720A	Recharge/Hose Hydrotest Adapter
N/S	HTA24	Hydrostatic Test Adapter

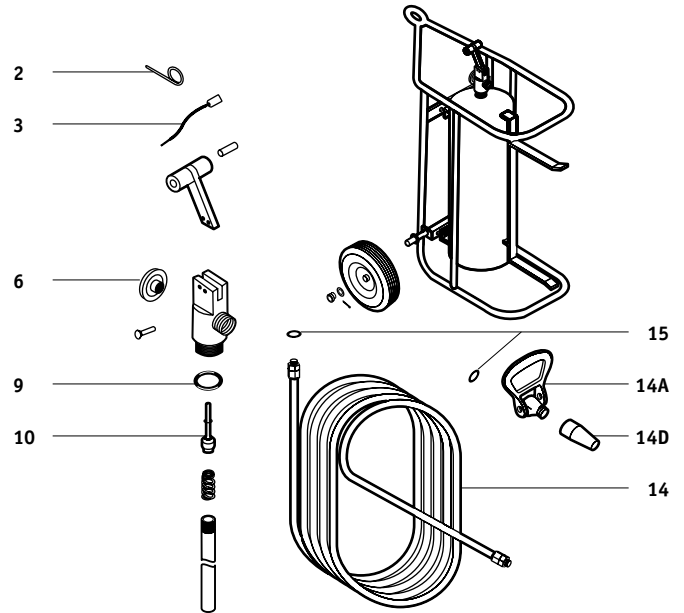

CYLINDER OPERATED DRY CHEMICAL WHEELED

B150A, B150AL, B125K, B125KL, B150R, B150RL, B150-A1, B150AL-1, B125K-1, B125KL-1, B150R-1, B150RL-1

FIG.	P/N	SERVICE & MAINTENANCE PART DESCRIPTION
3	3031BD	Pressure Regulator
8	3034B	Nitrogen Hose
10	4045B	Chemical Hose & Nozzle Gasket
11	20079BD	Chemical Hose Assembly (Special Order)

FIG.	P/N	ACCESSORY PART DESCRIPTION
N/S	CS10	Nitrogen Valve Lock Wire

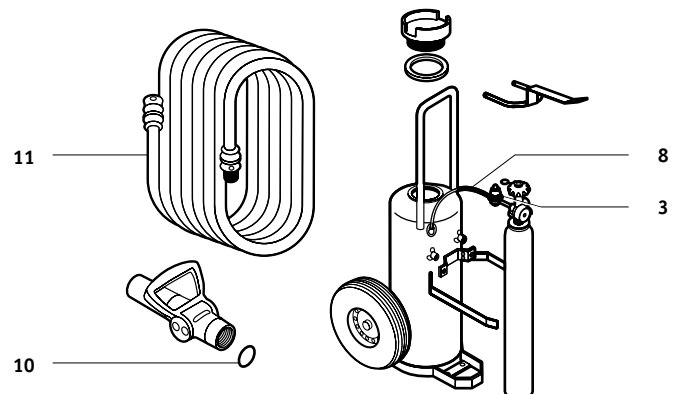

11 BUCKEYE - FIRE EXTINGUISHER PARTS

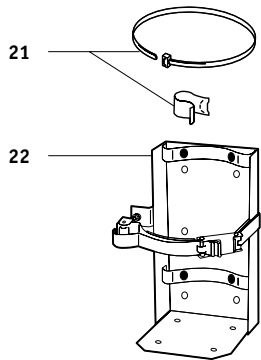
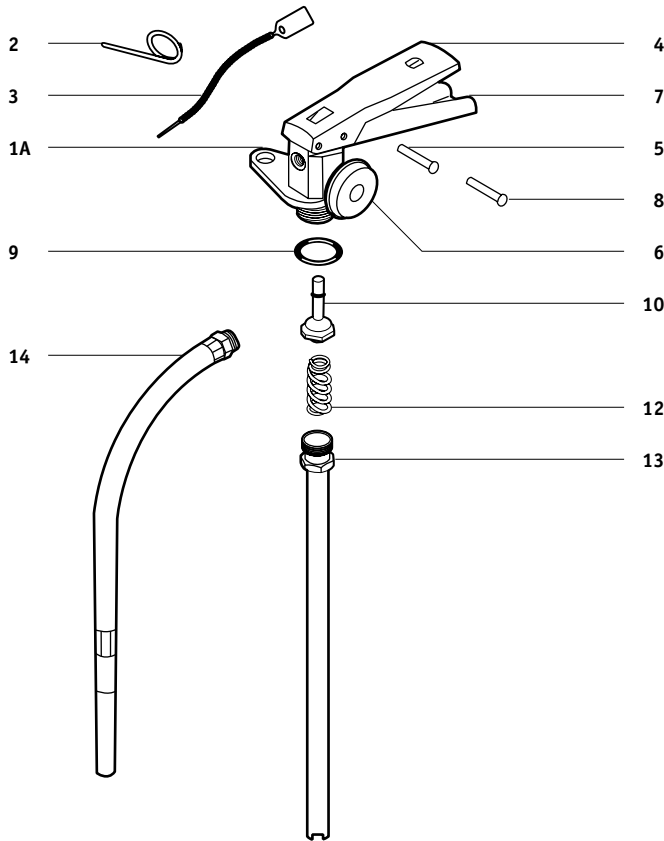

DRY CHEMICAL

5HI-SA40-ABC, 5HI-SB40-ABC, 5HI-SA-PK, 5.5HI-SA40-STD, 10HI-SA80-ABC, 10HI-SB80-ABC, 10S HI-SA-ABC, 10S HI-SA-STD, 10S HI-SA-PK, 10T HI-SA80-ABC, 10T HI-SB80-ABC, 10T HI-SA-STD, 10T HI-SB-STD, 10T HI-SA-PK, 10T HI-SB-PK, 20S HI-SA-ABC, 20S HI-SB-ABC, 20S HI-SA-STD, 20S HI-SA-PK, 20S HI-SB-PK, 30S HI-SB-ABC, 30S HI-SB-PK

HALON 1211

5HI-SA-1211-A, 5HI-SB-1211-A, 9HI-SA-1211, 9HI-SB-1211, 9S HI-SA-1211, 13HI-SA-1211, 13HI-SB-1211, 13S HI-SA-1211, 17S-SA-1211, 20S-SA-1211, 20S-SB-1211

HALOTRON I

5 - 24 lb, 5 FSA, 5HSA, 11SA, 11SB, 15SA, 15SB

FIG. P/N SERVICE & MAINTENANCE PART DESCRIPTION

1A	700201W	Hanger Loop (SA)
2		Pull Pin
3		Tamper Seal
4	900210W	Lever (SA)
4	900214W	Lever (SB)
5	900050W	Lever Rivet (SA)
5	900053W	Lever Rivet (SB)
6	G195	Gauge - 195 All Dry Chemical
6	G100H	Gauge - 100 (Halon) All 5 lb Halon
6	G195H	Gauge - 195 (Halon) All 9, 13, 17, 20 lb Halon
6	G100T	Gauge - 100 (Halotron I) All 5-11 lb Halotron I
6	G125T	Gauge - 125 (Halotron I) All 12, 14, 15 lb Halotron I
7	900228W	Handle (SA)
7	900232W	Handle (SB)
8	900049W	Handle Rivet (SA)
8	900052W	Handle Rivet (SB)
9	900001W	Collar O-Ring
9	900004W	Collar O-Ring All Halon
9	900010W	Collar O-Ring
9	900013W	Collar O-Ring All Steel Cylinder Halotron I
10	103215W	Valve Stem All Dry Chemical
10	103214W	Valve Stem All Halon
10	103216W	Valve Stem All Halotron I
12	900105W	Spring (Replaces 900101)
13	900960W	Siphon Tube All 5 HI, 5.5 HI
13	900962W	Siphon Tube All 10S HI
13	900963W	Siphon Tube All 10T HI
13	900971W	Siphon Tube All 10 HI, 20 HI
14	109267W	Hose & Nozzle Assembly (.128) 5 HI SA40 ABC
14	113277W	Hose & Nozzle Assembly (.144) 10 HI SA80 ABC, 10T HI SA80 ABC
14	126216W	Hose & Nozzle Assembly (.180) 20S HI SA ABC

FIG. P/N ACCESSORY PART DESCRIPTION

21		Universal Hose Strap/Clip
N/S	WH5	Wall Hanger All 5-5½ lb
N/S	WH15	Wall Hanger All 10 lb
N/S	WH20	Wall Hanger ALL 20S, 30S
N/S	700270W	Vehicle Bracket All 5 lb
22	5DC	Heavy-Duty Vehicle Bracket All 5 lb
22	5HB	Heavy-Duty Vehicle Bracket All 9-17 lb, Except 9S, 10S, 13, 17S
22	10HB	Heavy-Duty Vehicle Bracket All 9S, 10S, 13S, 17S
22	15HB	Heavy-Duty Vehicle Bracket All 20-30 lb
N/S	AD23	Recharge Adapter
N/S	HTA7	Hydrostatic Test Adapter

WET CHEMICAL

6 liter, 2.5 gallon

FIG.	P/N	SERVICE & MAINTENANCE PART DESCRIPTION
2		Pull Pin, Stainless Steel
3		Tamper Seal
4	900322W	Lever
5	900053W	Lever Rivet
6	G100K	Gauge - 100 psi
7	900919W	Handle
8	900052W	Handle Rivet
9	900916W	Collar O-Ring
10	900921W	Valve Stem Assembly
12	900928W	Spring
13	300465W	Siphon Tube, 6 L
13	300464W	Siphon Tube, 2.5 gal
13A	900930W	Siphon Tube O-Ring
14	WC6LDA	Hose & Wand Assembly w/ Nozzle, 6 L
14	900637W	Hose & Wand Assembly w/ Nozzle, 2.5 gal
14A	NOZ001WCA	Nozzle Assembly, 6 L
15	900941W	Hose O-Ring
N/S	BK600872	Wet Chemical Charge, 6 L

FIG.	P/N	ACCESSORY PART DESCRIPTION
1D	AV1	Pressure Valve & Cap Assembly
N/S	AVC	Pressure Cap, Pkg/50
N/S	CORE	Pressure Valve Core, Pkg/50
21		Universal Hose Strap/Clip
22	15HB	Heavy-Duty Vehicle Bracket
N/S	HTA10	Hydrostatic Test Adapter

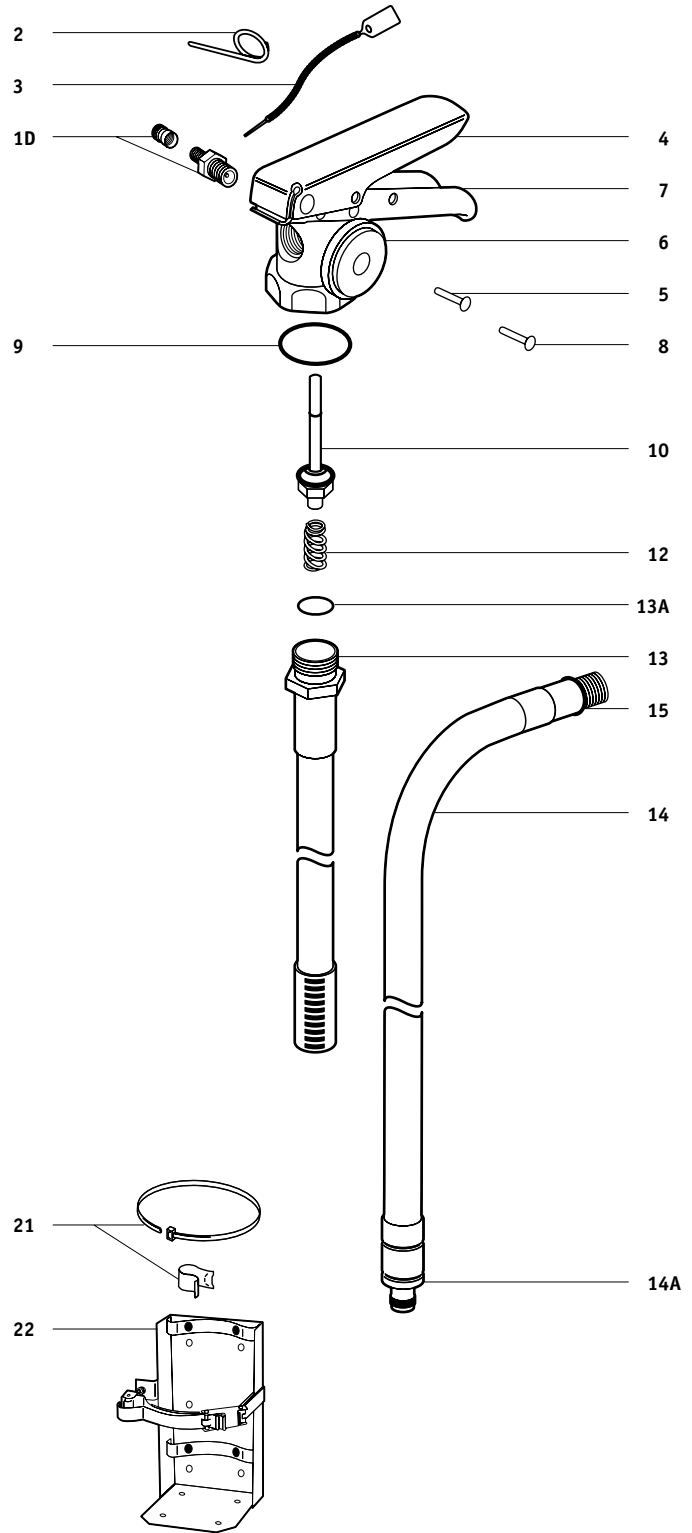

11 BUCKEYE - FIRE EXTINGUISHER PARTS

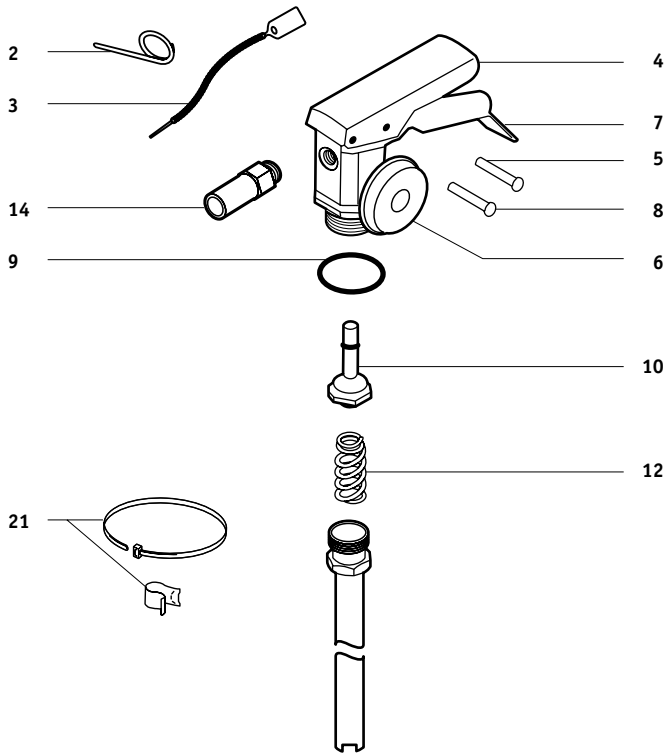

DRY CHEMICAL

2 STD-100, 2 PK-100, 2.5 STD-100, 2.5 ABC-100, 2.5 PK-100, M-5 ABC-II-100,
2.5 SA ABC, 2.5 SA STD, 2.5 SA PK

HALON 1211

1-1211, 2.2-1211, 2.5-1211

HALOTRON I

2.5 lb & 3 lb Models, 2.5 F SA, 2.5 H SA

FIG.	P/N	SERVICE & MAINTENANCE PART DESCRIPTION
2		Pull Pin
3		Tamper Seal
4	900209W	Lever (Aluminum Cylinders)
4	900217W	Lever (Steel Cylinders)
5	900050W	Lever Rivet
6	G100	Gauge - 100 All Dry Chemical
6	G100H	Gauge - 100 (Halon) All Halon
6	G100T	Gauge - 100 (Halotron I) All Halotron I
7	900218W	Handle (Steel Cylinders)
8	900049W	Handle Rivet
9	900004W	Collar O-Ring (Aluminum Cylinders) Dry Chemical, Halon 1211
9	900001W	Collar O-Ring (Steel Cylinders) Dry Chemical, Halon 1211
9	900013W	Collar O-Ring (Steel Cylinders) Halotron I
10	103215W	Valve Stem All Dry Chemical
10	103214W	Valve Stem All Halon
10	103216W	Valve Stem All Halotron I
12	900105W	Spring
14	101145W	Nozzle 2.5 ABC-100, 2.5 STD-100

FIG.	P/N	ACCESSORY PART DESCRIPTION
21		Universal Hose Strap/Clip M5 ABC-II-100
N/S	AD23	Recharge Adapter
N/S	HTA7	Hydrostatic Test Adapter

CARBON DIOXIDE

451, 456, 461, 466

FIG.	P/N	SERVICE & MAINTENANCE PART DESCRIPTION
1	149250WD	Valve Assembly
2		Pull Pin, Stainless Steel
3		Tamper Seal
4	900322W	Lever (200083)
5	900053W	Lever Rivet
6	200081W	Safety Disc, Gasket, & Nut Assembly
8	900052W	Handle Rivet
9	900329W	Collar O-Ring
10	900321W	Valve Stem Assembly
16	450202W	Elbow w/ O-Ring 5 lb
16A	900331W	Elbow O-Ring
17	453231W	Hose & Nozzle Assembly 10, 15, 20 lb
17	900310W	Swivel - Discharge Tube 5 lb
19	900313W	Horn 5 lb
19	900314W	Horn w/ Handle 10, 15, 20 lb

FIG.	P/N	ACCESSORY PART DESCRIPTION
N/S	RDS15	Hose Strap 10-15 lb
N/S	RDS20	Hose Strap 20 lb
N/S	RDBACLIP	Horn Clip 10, 15, 20 lb
N/S	SET6	Hardware Set 10, 15, 20 lb
N/S	BL209	Replacement Nameplate (Non-UL) 5 lb
N/S	BL210	Replacement Nameplate (Non-UL) 10-20 lb
N/S	WH5	Wall Hanger 5 lb
N/S	WH15	Wall Hanger 10, 15 lb
N/S	WH20	Wall Hanger 20 lb
22	5HB	Heavy-Duty Vehicle Bracket 5 lb
22	15HB	Heavy-Duty Vehicle Bracket 10, 15 lb
22	20HB	Heavy-Duty Vehicle Bracket 20 lb

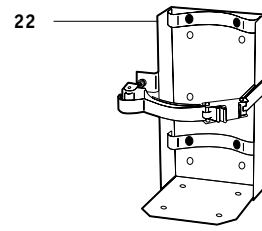
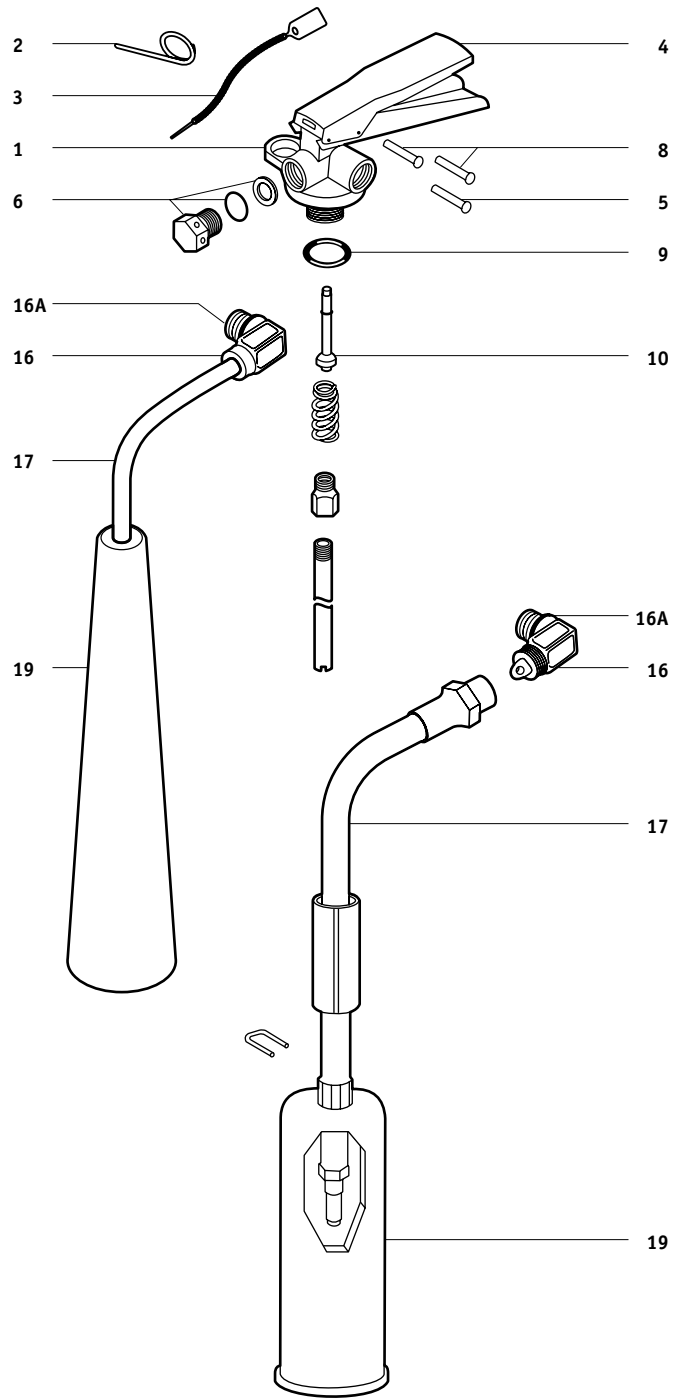

11 FLAG - FIRE EXTINGUISHER PARTS

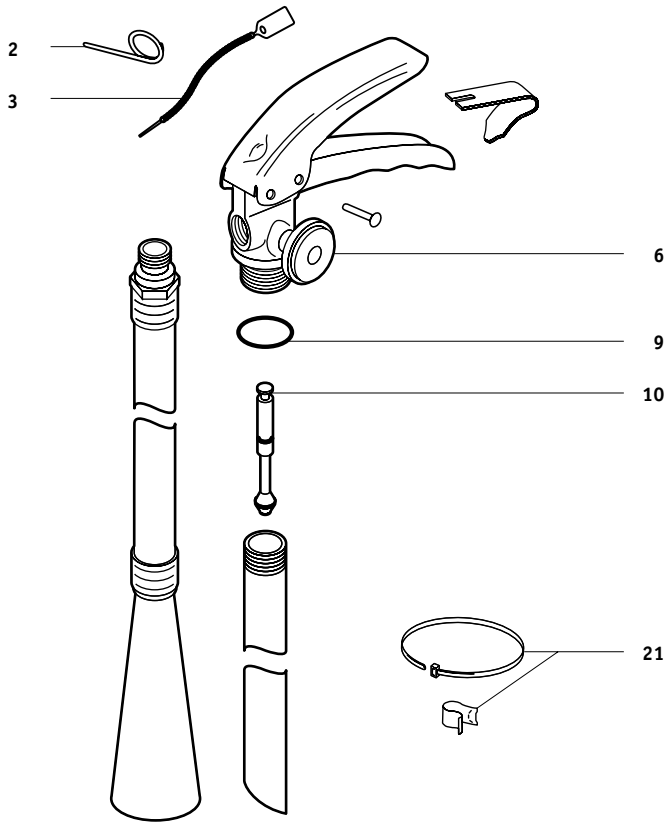

DRY CHEMICAL

10 - 30 lb G, H

FIG.	P/N	SERVICE & MAINTENANCE PART DESCRIPTION
2		Pull Pin
3		Tamper Seal
6	G175	Gauge - 175
9	429537AS	Collar O-Ring (Replaces 10513)
10	552144FG*	Valve Stem (Replaces 10990 & 429538)

FIG.	P/N	ACCESSORY PART DESCRIPTION
21		Universal Hose Strap/Clip
N/S	AD24	Recharge Adapter
N/S	HTA7	Hydrostatic Test Adapter

*WHILE QUANTITIES LAST!

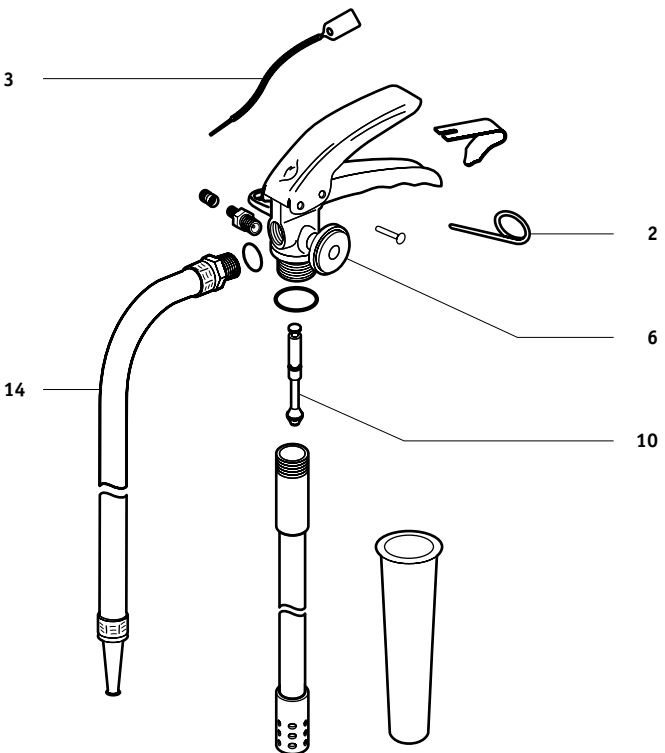

WATER

W02

WET CHEMICAL

K01

FIG.	P/N	SERVICE & MAINTENANCE PART DESCRIPTION
2		Pull Pin
3		Tamper Seal
6	G100WS	Gauge - 100
10	552144FG*	Valve Stem Assembly (Replaces 429538)
14	439495AS	Hose & Nozzle Assembly

FIG.	P/N	ACCESSORY PART DESCRIPTION
21		Universal Hose Strap/Clip
22	15HB	Heavy-Duty Vehicle Bracket
N/S	WH20	Wall Hanger

*WHILE QUANTITIES LAST!

DRY CHEMICAL

ProPlus 2.5MP, 5MP

HALOTRON I

ProPlus 2.5HM, 5HM

FIG. P/N SERVICE & MAINTENANCE PART DESCRIPTION

1A	19520B	Valve Body
1B	8516B	Hanger Loop
1C	19622B	Hanger Loop Screw
2		Pull Pin
3		Tamper Seal
5	18404B	Lever Rivet
6	G195	Gauge - 195
		All Dry Chemical
6	G100T	Gauge - 100 (Halotron I)
		All Halotron I
8	16517B	Handle Rivet
9	20745B	Collar O-Ring
		All Dry Chemical
9	23074B	Collar O-Ring
		All Halotron I
10	19010B	Valve Stem
		All Dry Chemical
10	23068B	Valve Stem
		All Halotron I
12	19393B	Spring
13	19825B	Siphon Tube
14	14816B	Nozzle
		2.5MP
14	19548B	Hose & Nozzle Assembly
		5MP

FIG. P/N ACCESSORY PART DESCRIPTION

21		Universal Hose Strap
N/S	WH5	Wall Hanger
N/S	MB250	Vehicle Bracket
		2.5MP
N/S	MB5	Vehicle Bracket
		5MP
22	5DC	Heavy-Duty Vehicle Bracket
		5MP
N/S	AD21	Recharge Adapter
N/S	HTA45	Hydrostatic Test Adapter

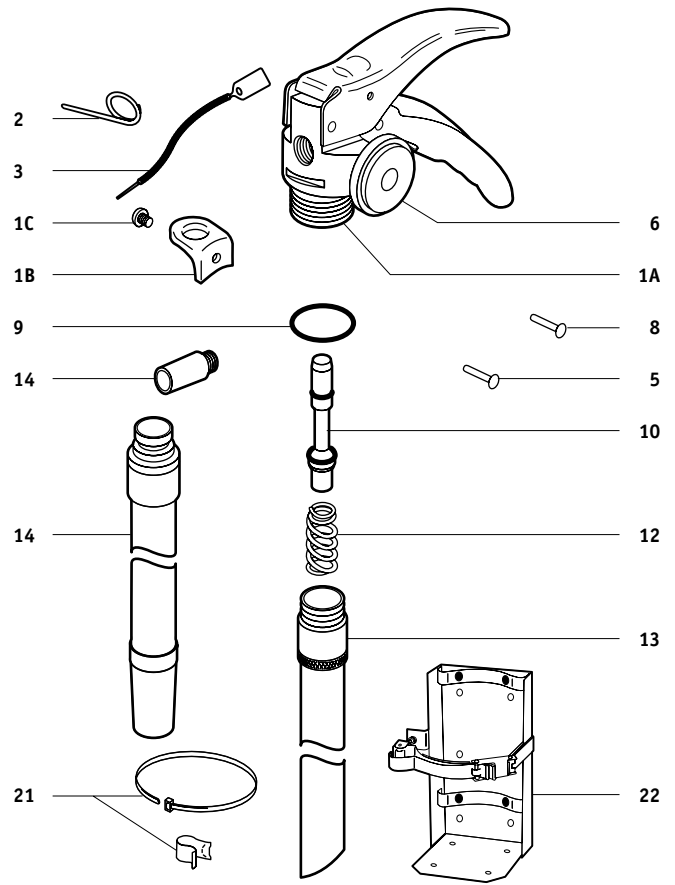

11 KIDDE - FIRE EXTINGUISHER PARTS

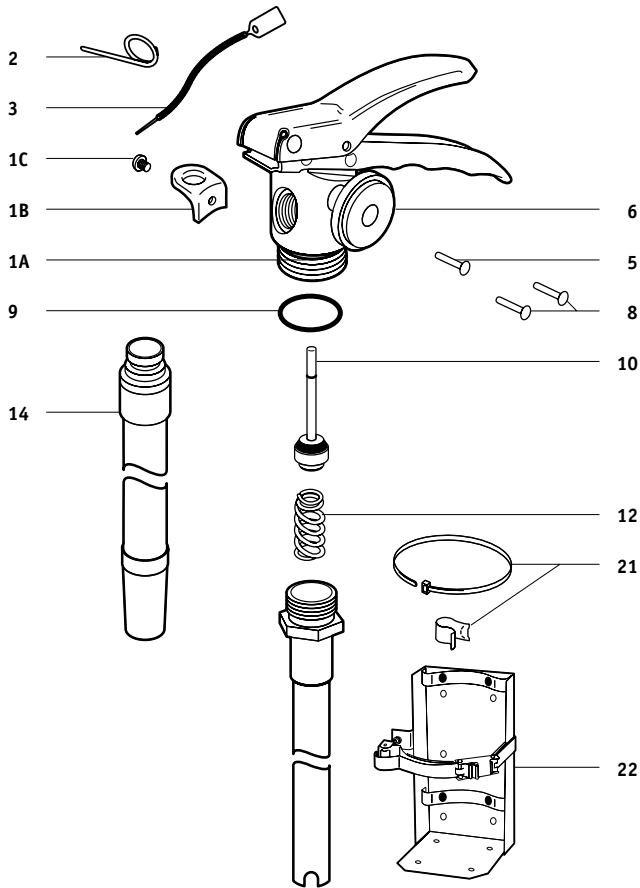

DRY CHEMICAL

ProPlus 10MP, 20MP

FIG.	P/N	SERVICE & MAINTENANCE PART DESCRIPTION
1A	16459B	Valve Body
1B	8516B	Hanger Loop
1C	19622B	Hanger Loop Screw
2		Pull Pin
3		Tamper Seal
5	16633B	Lever Rivet
6	G195	Gauge - 195
8	23354B	Handle Rivet
9	20746B	Collar O-Ring
10	12426B	Valve Stem
12	7630B	Spring
14	22601B	Hose & Nozzle Assembly 10MP

FIG.	P/N	ACCESSORY PART DESCRIPTION
21		Universal Hose Strap
N/S	WH5	Wall Hanger 10MP
N/S	WH15	Wall Hanger 20MP
22	5HB	Heavy-Duty Vehicle Bracket 10MP
22	15HB	Heavy-Duty Vehicle Bracket 20MP
N/S	AD24	Recharge Adapter
N/S	HTA44	Hydrostatic Test Adapter

HALOTRON I

ProPlus 11HM, 15.5HM

FIG.	P/N	SERVICE & MAINTENANCE PART DESCRIPTION
1B	23358B	Hanger Loop
1C	21390B	Hanger Loop Screw
2		Pull Pin
3		Tamper Seal
5	16633B	Lever Rivet
6	G125T	Gauge-125 (Halotron I) All Halotron I
8	23354B	Handle Rivet
9	23089B	Collar O-Ring
10	23086B	Valve Stem
12	7630B	Spring

FIG.	P/N	ACCESSORY PART DESCRIPTION
21		Universal Hose Strap
N/S	WH5	Wall Hanger 11HM
N/S	WH15	Wall Hanger 15.5HM
22	5HB	Heavy-Duty Vehicle Bracket 11HM
22	15HB	Heavy-Duty Vehicle Bracket 15.5HM
N/S	AD24	Recharge Adapter
N/S	HTA44	Hydrostatic Test Adapter

DRY CHEMICAL

PRO2.5TCM-8, PRO4TCM-8, PRO5TCM-8, PRO10TCM-9, PROM10TCM-8, PRO20TCM-9, PRO20TCM-8

FIG.	P/N	SERVICE & MAINTENANCE PART DESCRIPTION
1A	8516B	Hanger Loop
1B	19622B	Hanger Loop Screw
2		Pull Pin
3		Tamper Seal
4	21007875B	Lever
5	320750B	Lever Rivet
6	G100	Gauge - 100
6	G195	Gauge - 195
→7	300558K	Handle 1.5-10 lb
→7	21007874K	Handle 20 lb
8	320751B	Handle Rivet
9	340035K	Collar Seal
10	440068K	Valve Stem
11	259772K	Valve Stem O-Ring
12	322063B	Spring
N/S	320167K	Siphon Tube O-Ring
14	21006335B	Hose & Nozzle Assembly 5 lb
14	21007908B	Hose & Nozzle Assembly 10 lb

FIG.	P/N	ACCESSORY PART DESCRIPTION
21		Universal Hose Strap/Clip
N/S	1141K	Wall Hanger 2.5 lb
N/S	23704B	Wall Hanger 4-10 lb
N/S	14260K	Wall Hanger 20 lb
N/S	AD23	Recharge Adapter
N/S	HTA18	Hydrostatic Test Adapter

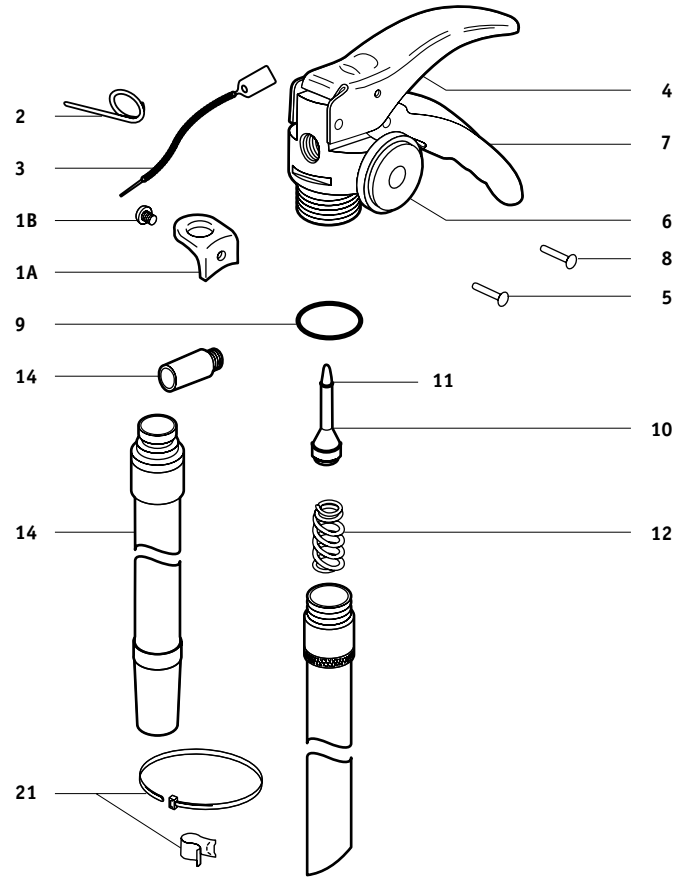

11 KIDDE - FIRE EXTINGUISHER PARTS

DRY CHEMICAL

PRO2.5TCM-6, PRO2.62TCM-5, PRO2.5MP, PRO2.75RM-6, PRO2.75RM-5, PRO2.75R, PRO4TCM-6, PRO4TCM-4, PRO4MP, PRO5TCM-6, PRO5TCM-4, PRO5MP, PRO6RM-4, PRO6R, PRO10TCM-6, PRO10TCM-5, PRO10TCM-4, PRO10MP, PRO10RM-5, PRO10RM-4, PRO10R, PRO10PKM-3, PRO10PK, PRO20TCM-6, PRO20TCM-5, PRO20TCM-4, PRO20MP, PRO20RM-5, PRO20RM-4, PRO20R, PRO20PKM-5, PRO20PKM-3, PRO20PK

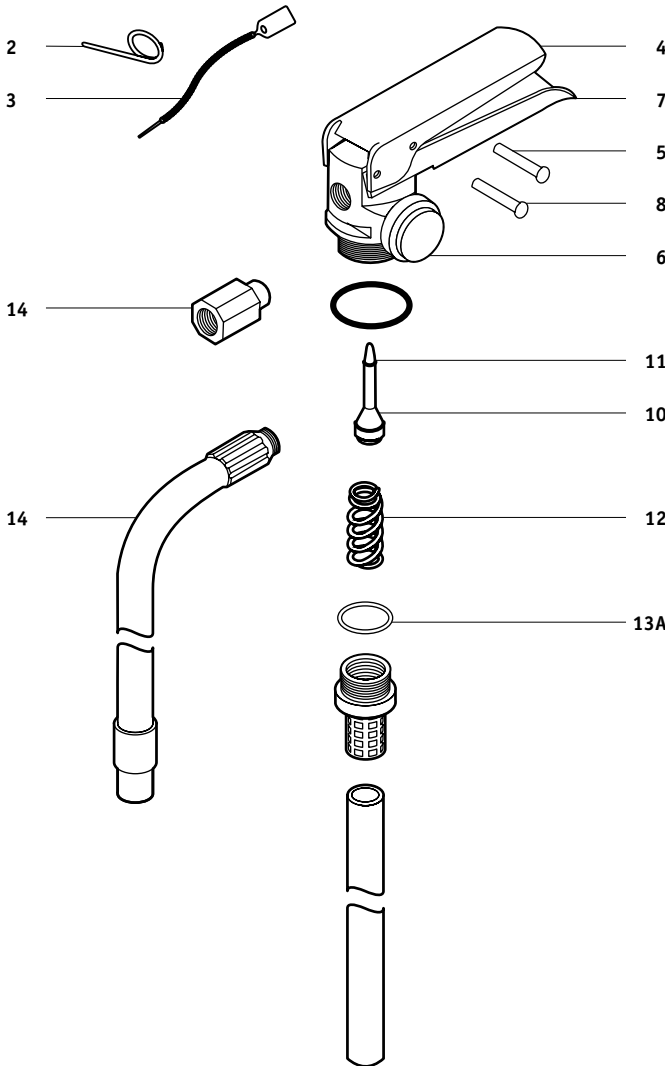
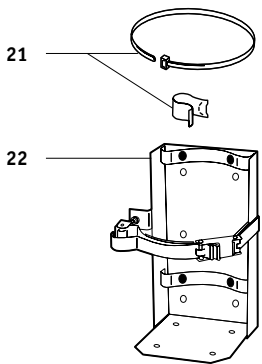

FIG. P/N SERVICE & MAINTENANCE PART DESCRIPTION

2		Pull Pin
3		Tamper Seal
4	18363B	Lever
5	18404B	Lever Rivet
6	G100	Gauge - 100 2.5-4 lb
6	G195	Gauge - 195 5-20 lb
7	18361B	Handle
8	16517B	Handle Rivet
10	440068K	Valve Stem
11	259772K	Valve Stem O-Ring
12	320732K	Spring
13A	320167K	Siphon Tube O-Ring
14	440089K	Hose & Nozzle Assembly PRO5TCM-4, PRO5MP
14	440330K	Hose & Nozzle Assembly PRO20TCM-5, PRO20MP

FIG. P/N ACCESSORY PART DESCRIPTION

21		Universal Hose Strap/Clip
N/S	340357K	Wall Hanger All 2.5-2.75 lb
N/S	340358K	Wall Hanger All 4-6 lb
N/S	340791K	Wall Hanger All 10 lb
22	5DC	Heavy-Duty Vehicle Bracket All 4-6 lb
22	5HB	Heavy-Duty Vehicle Bracket All 10 lb
22	15HBL	Heavy-Duty Vehicle Bracket All 20 lb
N/S	AD23	Recharge Adapter
N/S	HTA45	Hydrostatic Test Adapter
N/S	HTA18	Hydrostatic Test Adapter



DRY CHEMICAL (To 1991)

2 3/4RM, 2 5/8TCM, 5TCM, 6RM, 6TCM, 10RM, 10RM-1, 10TCM, 10TCM-1, 20RM, 20RM-1, 20TCM, 20TCM-1

HALON 1211 (To 1991)

2.5HM, 5HM, 9HM, 13HM-1, 17HM-1, 20HM-1

FIG. P/N SERVICE & MAINTENANCE PART DESCRIPTION

2		Pull Pin
3		Tamper Seal
6	G100	Gauge - 100 All 2.6-4 lb Dry Chemical
6	G195	Gauge - 195 All 5-20 lb Dry Chemical
6	G100H	Gauge - 100 (Halon) All 2.5-6 lb Halon
6	G195H	Gauge - 195 (Halon) All 9-20 lb Halon
9	340035K	Collar Seal All Dry Chemical, Except 20 lb RM, RM-1, TCM, TCM-1
9	340037K	Collar Seal 10-20 lb RM, RM-1, TCM, TCM-1
10	440020K*	Valve Stem All Dry Chemical
11	259772K	Valve Stem O-Ring All Dry Chemical
13A	320167K	Siphon Tube O-Ring

FIG. P/N ACCESSORY PART DESCRIPTION

21		Universal Hose Strap/Clip
N/S	1141K	Wall Hanger (Replaces 320075 & 320688K) 2-10 lb RM, TCM, 5-13 lb Halon
N/S	466400K	Vehicle Bracket (Replaces 896697) 6RM, 6TCM, 5TCM, 5HM, 9HM
N/S	466401K	Vehicle Bracket (Replaces 896698) 2 3/4RM, 2 5/8TCM, 2.5HM
N/S	AD35	Recharge Adapter
N/S	AD23	Recharge Adapter
N/S	HTA18	Hydrostatic Test Adapter
N/S	HTA5	Hydrostatic Test Adapter

*WHILE QUANTITIES LAST!

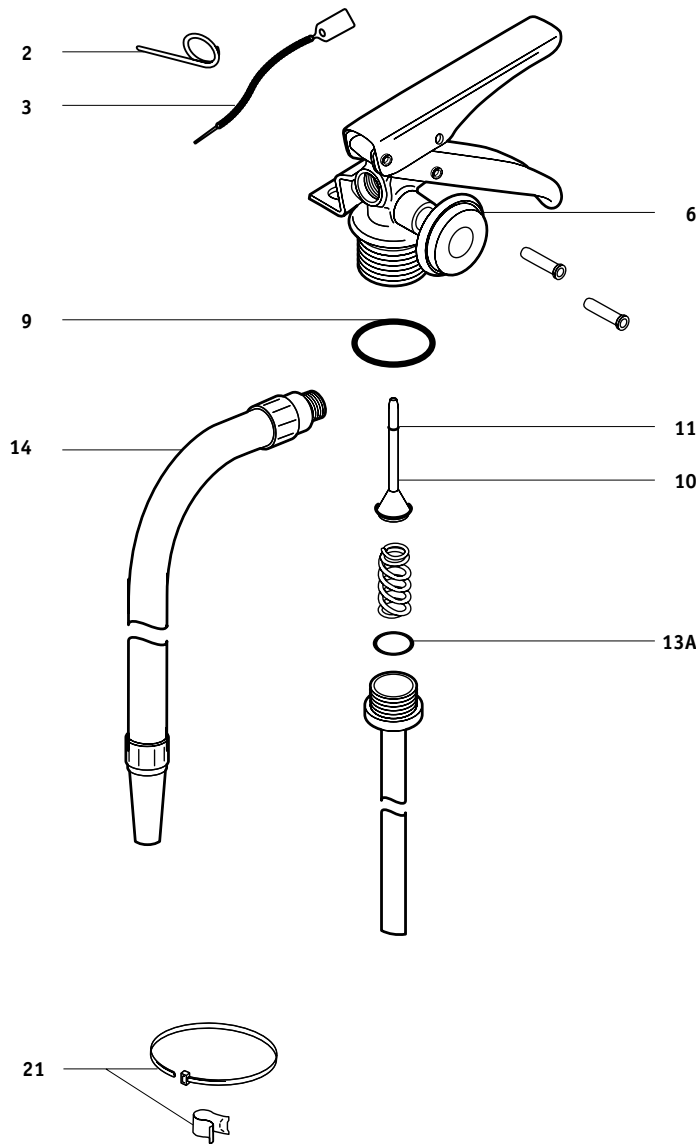

11 KIDDE - FIRE EXTINGUISHER PARTS

DRY CHEMICAL (From 1991)

2 3/4RM-2, -3, -4, 2 5/8TCM-2, -3, -4, 4TCM-3, 5TCM-2, -3, 6RM-2, -3, 10RM-2, 10TCM-2, 20RM-2, -3, 20TCM-2, -3

HALON 1211 (From 1991)

2.5HM-2, -3, 5HM-2, -3, 9HM-2, -3, 13HM-3, 17HM-2, 20HM-2

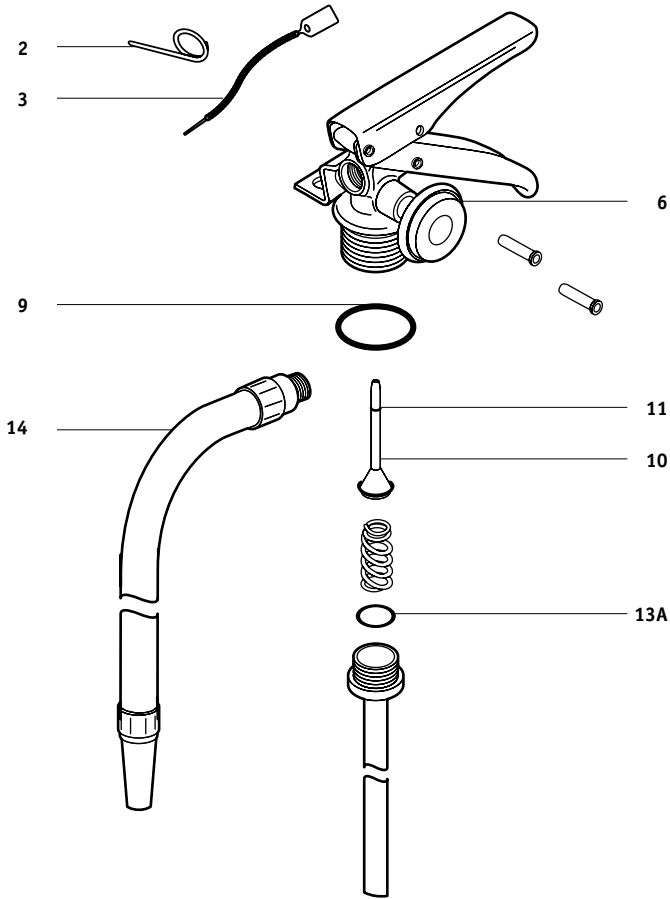

FIG. P/N SERVICE & MAINTENANCE PART DESCRIPTION

2		Pull Pin
3		Tamper Seal
6	G100	Gauge - 100
6	G195	All 2.6-4 lb Dry Chemical Gauge - 195
6	G100H	All 5-20 lb Dry Chemical Gauge - 100 (Halon)
6	G195H	All 2.5-6 lb Halon Gauge - 195 (Halon)
9	340035K	All 9-20 lb Halon Collar Seal
10	440020K*	All Dry Chemical Valve Stem
11	259772K	All Dry Chemical Valve Stem O-Ring
13A	320167K	All Dry Chemical Siphon Tube O-Ring
14	440089K	Hose & Nozzle Assembly 5TCM-2, 5TCM-3

FIG. P/N ACCESSORY PART DESCRIPTION

21		Universal Hose Strap/Clip
N/S	1141K	Wall Hanger (Replaces 320075 & 320688K) 5TCM-2, 6RM-2, 10RM-2, -3, 10TCM-2, -3, 5-13 lb Halon
N/S	466400K	Vehicle Bracket (Replaces 896697) 5TCM-2, 6RM-2, 5HM-2, 9HM-2
N/S	466401K	Vehicle Bracket (Replaces 896698) 2 3/4RM-2, -3, 2 5/8TCM-2, -3, 2.5HM-2
N/S	AD23	Recharge Adapter
N/S	HTA18	Hydrostatic Test Adapter

*WHILE QUANTITIES LAST!

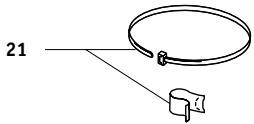

DRY CHEMICAL

10RAS-3, -4, -5, -6, 10TAS-3, -4, -5, -6, 20RAS-3, -4, -5, -6, -7, 20TAS-3, -4, -5, -6, -7, 30RAS-3

FIG.	P/N	SERVICE & MAINTENANCE PART DESCRIPTION
2		Pull Pin
3		Tamper Seal
6	G195	Gauge - 195 All 10 lb, 20RAS-7, 20TAS-7
6	G235	Gauge - 235 All 20 lb, 30RAS-3, Except 20RAS-7, 20TAS-7
9	340037K	Collar Seal 1985 & After
9	64350218K	Collar O-Ring 1985 & Before
10	877546K	Valve Stem Assembly
11	259772K	Valve Stem O-Ring

FIG.	P/N	ACCESSORY PART DESCRIPTION
21		Universal Hose Strap/Clip
N/S	WH5	Wall Hanger 10 lb
22	5HB	Heavy-Duty Vehicle Bracket 10 lb
22	15HB	Heavy-Duty Vehicle Bracket 20-30 lb
N/S	AD34	Recharge Adapter
N/S	HTA5	Hydrostatic Test Adapter

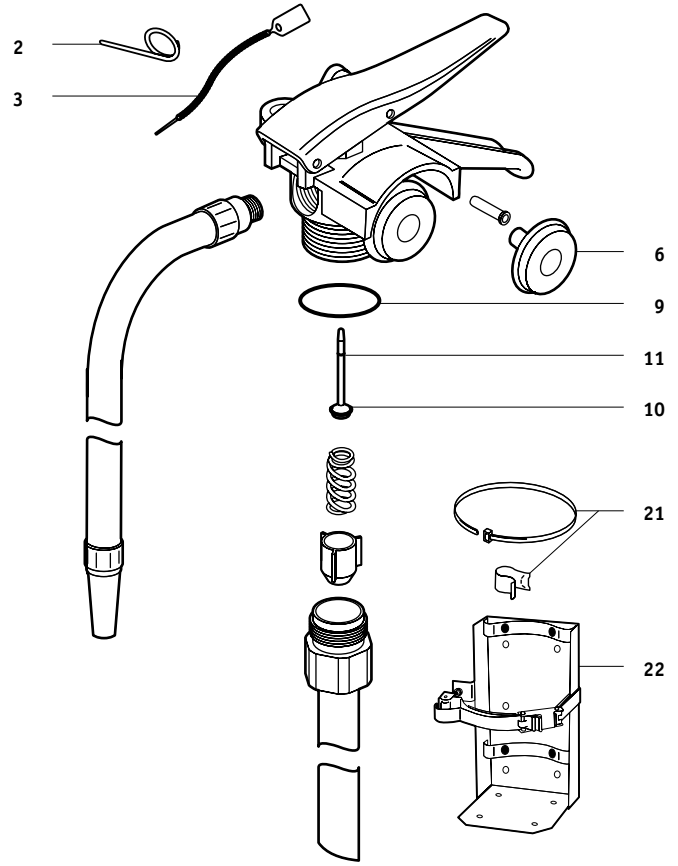

DRY CHEMICAL

10TAP, 10RAP, XL10TCZ, XL10RZ, FA460

FIG.	P/N	SERVICE & MAINTENANCE PART DESCRIPTION
2		Pull Pin
3		Tamper Seal
6	293266K	Gauge - 195
6A	259535K	Gauge O-Ring
9	340037K	Collar Seal Newer w/ Molded Seal
10	877546K	Valve Stem
11	259772K	Valve Stem O-Ring

FIG.	P/N	ACCESSORY PART DESCRIPTION
21		Universal Hose Strap/Clip
N/S	WH5	Wall Hanger
22	5HB	Vehicle Bracket
N/S	AD32	Recharge Adapter
N/S	HTA39	Hydrostatic Test Adapter

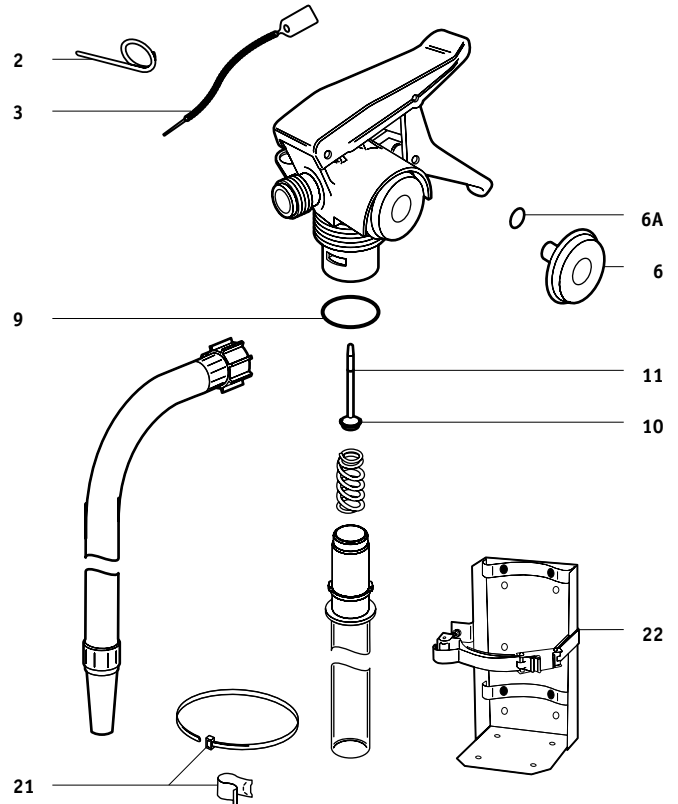

11 KIDDE - FIRE EXTINGUISHER PARTS

CARBON DIOXIDE

5CDM, 5KS-3, 10CDM, 10KS-3, 15CDM, 15KS-3, 15KS-4, 20CDM, 20KS-4

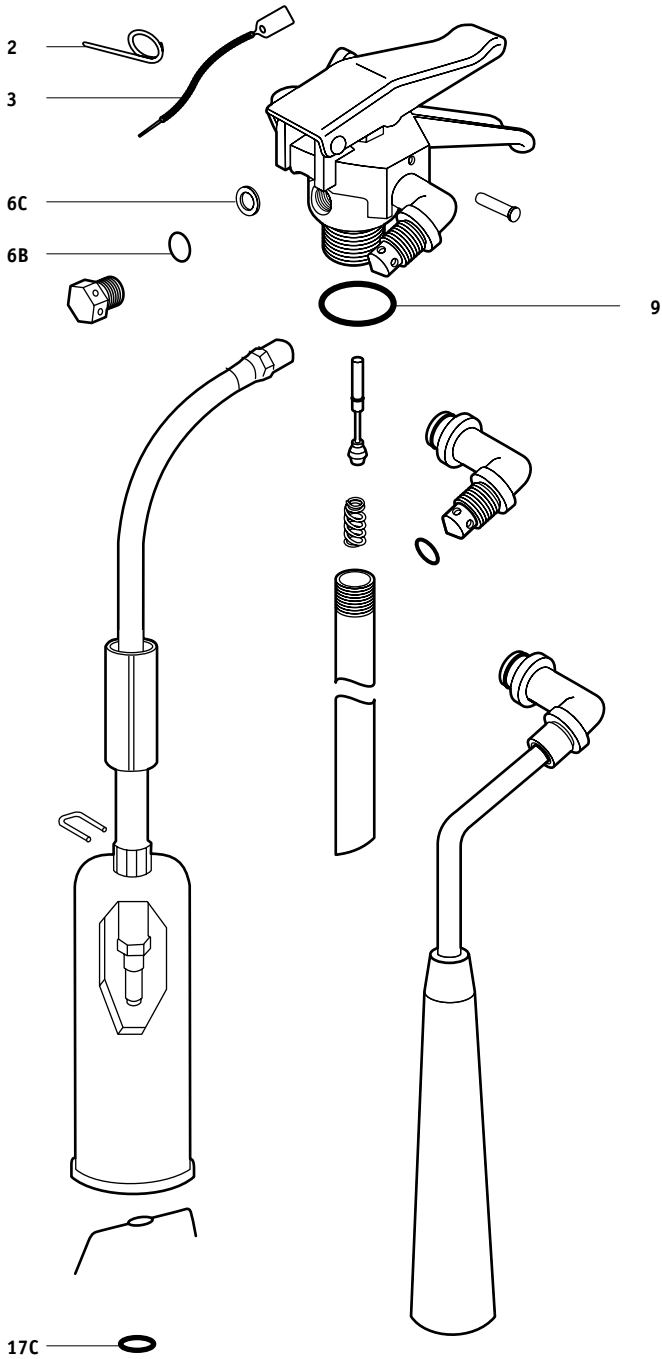
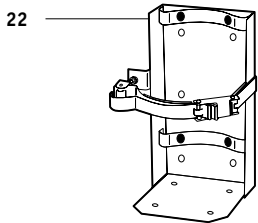

FIG.	P/N	SERVICE & MAINTENANCE PART DESCRIPTION
2		Pull Pin
3		Tamper Seal
6B	260299K	Safety Disc
6C	258443K	Safety Disc Gasket
9	320130K	Collar O-Ring
17C	213885K	Push Nut

FIG.	P/N	ACCESSORY PART DESCRIPTION
N/S	RDS15	Strap 10, 15 lb
N/S	RDS20	Strap 20 lb
N/S	RDBACLIP	Horn Clip 10-20 lb
N/S	SET6	Hardware Set 10-20 lb
N/S	BL209	Replacement Nameplate (Non-UL) 5 lb
N/S	BL210	Replacement Nameplate (Non-UL) 10-20 lb
N/S	WH5	Wall Hanger 5 lb
N/S	WH15	Wall Hanger 10, 15 lb
N/S	WH20	Wall Hanger 20 lb
22	5HB	Heavy-Duty Vehicle Bracket 5 lb
22	15HB	Heavy-Duty Vehicle Bracket 10, 15 lb
22	20HB	Heavy-Duty Vehicle Bracket 20 lb



CARBON DIOXIDE

5CDM-1, 5CDM-2, 10CDM-1, 10CDM-2, 15CDM-1, 15CDM-2, 20CDM-1, 20CDM-2

FIG.	P/N	SERVICE & MAINTENANCE PART DESCRIPTION
2		Pull Pin
3		Tamper Seal
6B	260299K	Safety Disc
6C	258443K	Safety Disc Gasket
9	320130K	Collar O-Ring

FIG.	P/N	ACCESSORY PART DESCRIPTION
N/S	RDS15	Strap All 10, 15 lb
N/S	RDS20	Strap 20 lb
N/S	RDBACLIP	Horn Clip 10-20 lb
N/S	SET6	Hardware Set 10-20 lb
N/S	BL209	Replacement Nameplate (Non-UL) 5 lb
N/S	BL210	Replacement Nameplate (Non-UL) 10, 15, 20 lb
N/S	WH5	Wall Hanger 5 lb
N/S	WH15	Wall Hanger 10, 15 lb
N/S	WH20	Wall Hanger 20 lb
22	5HB	Heavy-Duty Vehicle Bracket 5 lb
22	15HB	Heavy-Duty Vehicle Bracket 10, 15 lb
22	20HB	Heavy-Duty Vehicle Bracket 20 lb

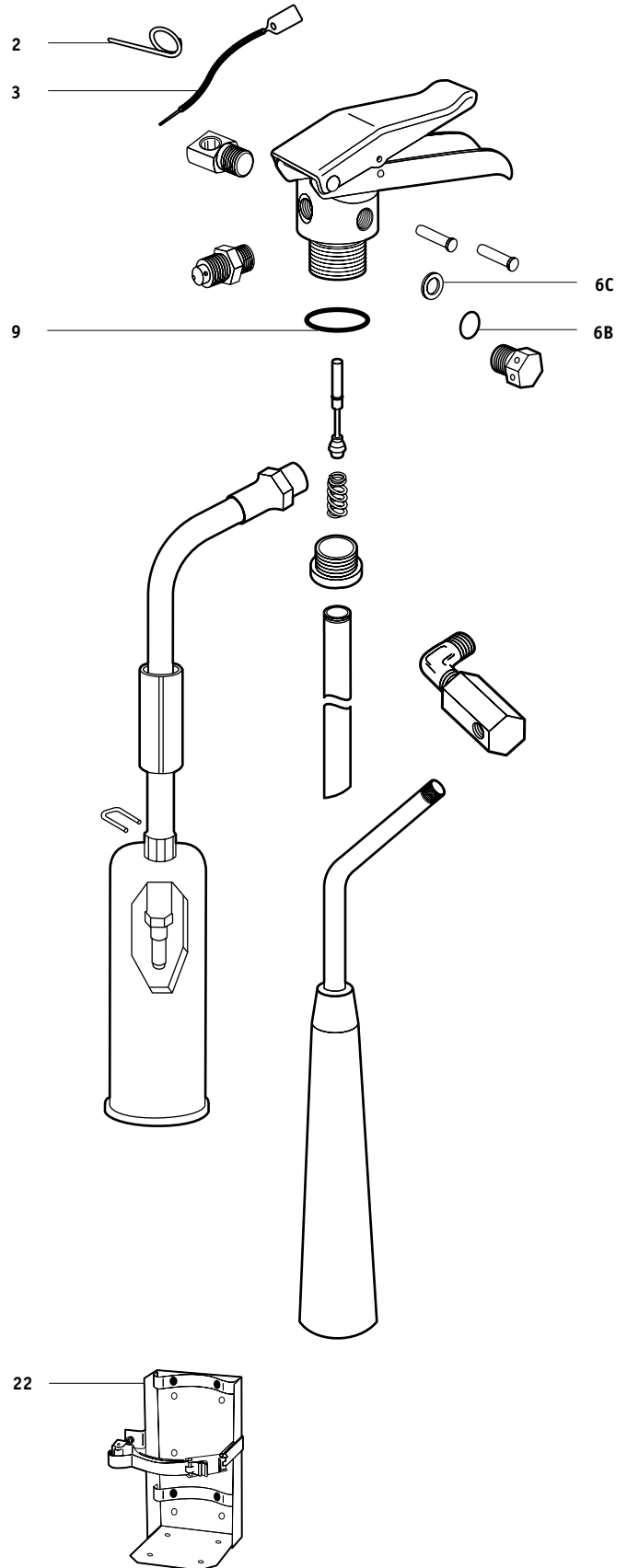

Carbon Dioxide Pro CDM-3 Models with "Model B-9" Valves manufactured by Badger, see page 275.

11 STRIKE FIRST - FIRE EXTINGUISHER PARTS

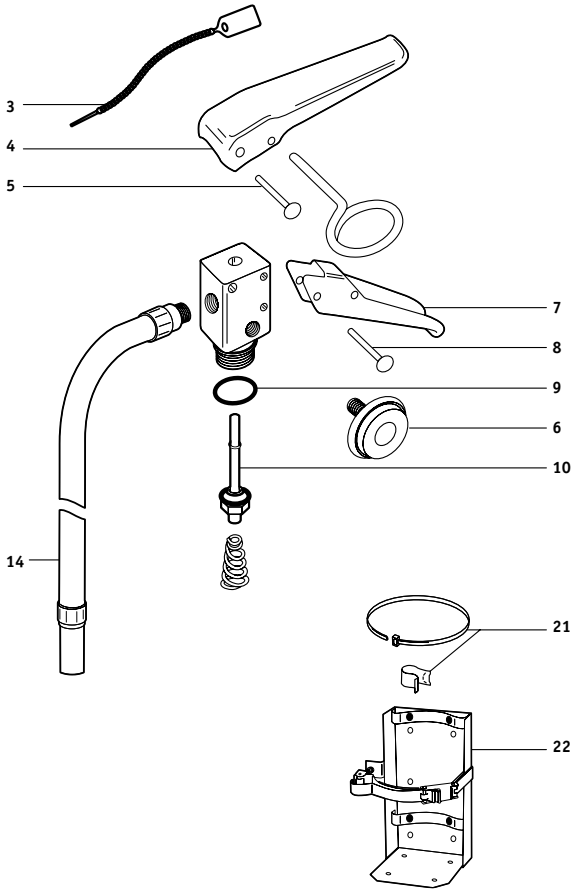

DRY CHEMICAL (Large Valve) SF-5, SF-5HP, SF-10, SF-20

FIG	P/N	SERVICE & MAINTENANCE PART DESCRIPTION
3		Tamper Seal
4	160414SF	Lever 5-20 lb
5	162803SF	Lever Rivet
6	G195	Gauge - 195 5 lb
6	G235	Gauge - 235 10-20 lb
7	160395SF	Handle 5-20 lb
8	162803SF	Handle Rivet
9	161345SF	Collar O-Ring
10	161428SF	Valve Stem
14	161605SF	Hose & Nozzle Assembly SF - 5

FIG.	P/N	ACCESSORY PART DESCRIPTION
21		Universal Hose Strap
22	5DC	Heavy-Duty Vehicle Bracket 5 lb
N/S	AD24	Recharge Adapter
N/S	HTA7	Hydrostatic Test Adapter

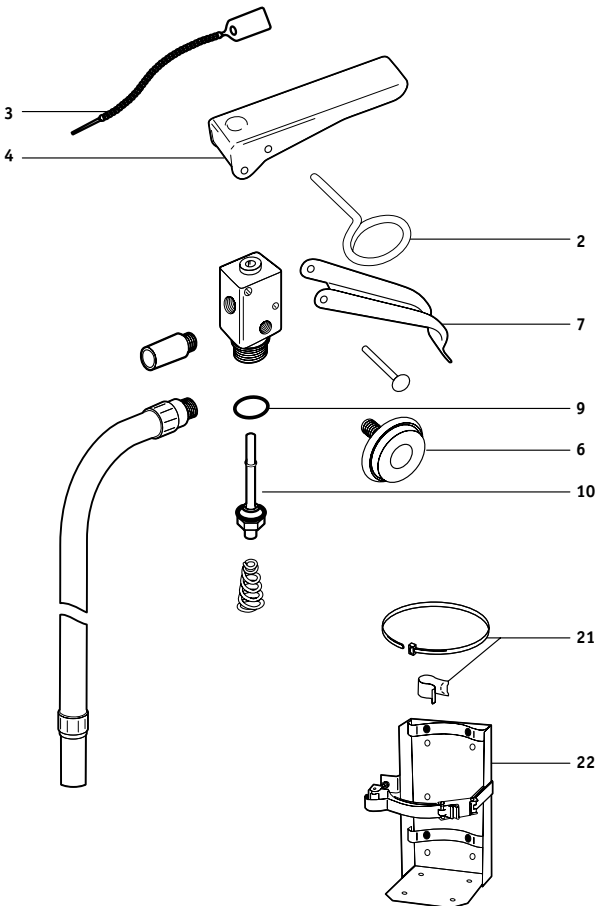

DRY CHEMICAL (Small Valve) SF-2.5, SF-5 & SF-5HP

FIG	P/N	SERVICE & MAINTENANCE PART DESCRIPTION
2		Pull Pin
3		Tamper Seal
4	110414SF	Lever 2.5 lb
6	G150	Gauge - 150 2.5 lb
6	G195	Gauge - 195 5 lb
7	110396SF	Handle
9	110345SF	Collar O-Ring
10	110427SF	Valve Stem

FIG.	P/N	ACCESSORY PART DESCRIPTION
21		Universal Hose Strap
N/S	AD23	Recharge Adapter
22	5DC	Heavy-Duty Vehicle Bracket 5 lb

CARBON DIOXIDE FIRE EXTINGUISHER VALVES

5 - 20 lb Brooks (BECO), Fyr-Fyter, C-0-TWO, RS, Superior, BHV50, BHV100

FIG	P/N	SERVICE & MAINTENANCE PART DESCRIPTION
2	NPPS	Pull Pin, Stainless Steel BECO, RS, Superior
4	RS0102	Lever (P5970-8S) BECO, RS, Superior
4	4BHV	Lever BHV50, BHV100
5	RV10	Lever Rivet BECO
5	RS0103	Lever Roll Pin (P5970-6S) RS, Superior
5	5BHV	Lever & Handle Rivet Set BHV50, BHV100
6	RS5	Safety Disc, Washer & Nut Assembly RS
6	16ASV	Safety Disc (P1200-16AS) Superior Military-Style Extinguisher
6	C16SV	Safety Disc (P5970-16S) Superior 5-20 lb
6	C15SV	Washer (P6038A-15SB) Superior 5-20 lb
6	50116F	Washer Fyr-Fyter, C-0-Two
6	50115F	Safety Disc Fyr-Fyter, C-0-Two
6	6BHV	Safety Disc, Washer & Nut Assembly BHV50, BHV100
7	PSH4	Handle BECO
7	RS0104	Handle (P6037-12SS) RS, Superior
7	7BHV	Handle BHV50, BHV100
9	OR295	Collar O-Ring RS PSH-A, PSH-5AL
10	PSH6	Valve Stem BECO
10	418682AS	Valve Stem (P5970-21SB, RS-0108) RS, Superior
10	10BHV	Valve Stem BHV50, BHV100
11	OR4	Valve Stem O-Ring BECO, RS, Superior
12	12BHV	Spring BHV50, BHV100
14	RS0110	Copper Seal, Lead Coated, Pkg/10 BECO, RS
14	14BHV	Copper Seal BHV50, BHV100
15	EL250	Siphon Tube 1/4" Elbow & Diffuser All 10-20 lb
16	EL375	3/8" Elbow & Diffuser All 10-20 lb
N/S	DC	Discharge Tube BECO, Fyr-Fyter, C-0-Two 2 1/2-5 lb
17	SW50	Swivel Discharge Assembly RS, Superior, BHV50 2 1/2-5 lb
17		Hose Assembly All 10-20 lb
18	RDN	Diffuser All 10-20 lb
19	STB114	Horn 5 lb w/ Diffuser in Discharge Tube
19	RDH10	Horn w/ Handle 10 lb
19	RDH15	Horn w/ Handle 15-20 lb
20	RDC	Diffuser Clip 10-20 lb

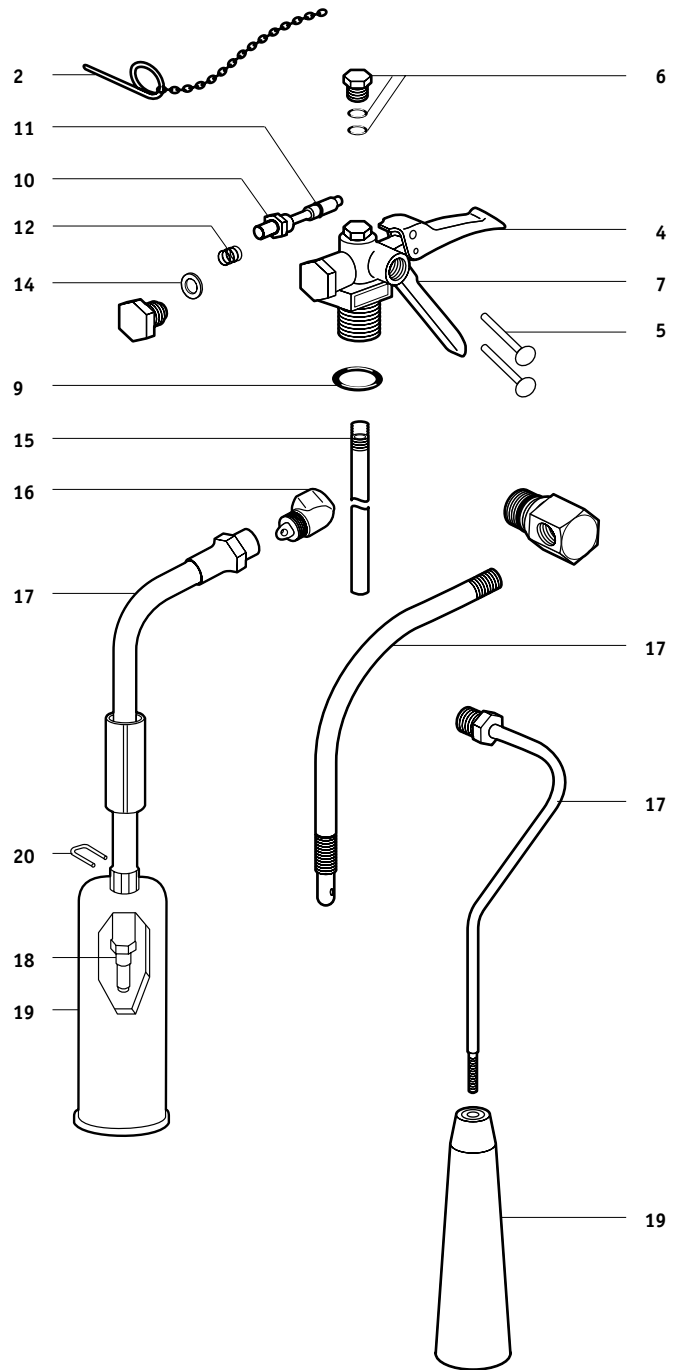

11 SHERWOOD - FIRE EXTINGUISHER PARTS

"GLOBAL" SERIES

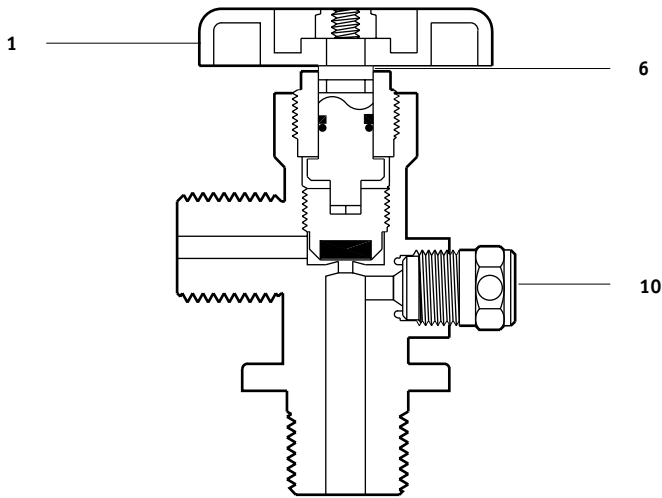

CARBON DIOXIDE & NITROGEN COMMERCIAL VALVES

GV Series "Global" Industrial Valves

FIG.	P/N	SERVICE & MAINTENANCE PART DESCRIPTION
1	A1919GV	Hand Wheel, Aluminum
1	L1919GV	Hand Wheel, Plastic
6	30101GV	Bonnet & Operating Stem Assembly
10	N928GV	Safety Plug, Disc & Gasket Carbon Dioxide (For DOT 1800 Cylinders)
10	N932GV	Safety Plug, Disc & Gasket Nitrogen (For DOT 2015 Cylinders)
N/S	OR39	Collar O-Ring GV Valves w/ Straight Threads for Aluminum Cylinders

CARBON DIOXIDE & NITROGEN COMMERCIAL VALVES

TV Series Industrial Valves

FIG.	P/N	SERVICE & MAINTENANCE PART DESCRIPTION
1	1401TV	Hand Wheel, Metal
1	L1401TV	Hand Wheel, Plastic
2	1003TV	Hand Wheel Nut, Pkg/10
5	1012TV	Hand Wheel Spring
6	5030TV	Operating Stem
7	5006TV	Packing
8	5040TV	Lower Stem & Seat Insert Assembly
9	1413TV	Hand Wheel Gasket (Fibre)
10	928TV	Safety Cap, Disc & Gasket Carbon Dioxide (For DOT 1800 Cylinders)
10	932TV	Safety Cap, Disc & Gasket Nitrogen (For DOT 2015 Cylinders)
N/S	OR39	Collar O-Ring TV Valves w/ Straight Threads for Aluminum Cylinders

TV SERIES

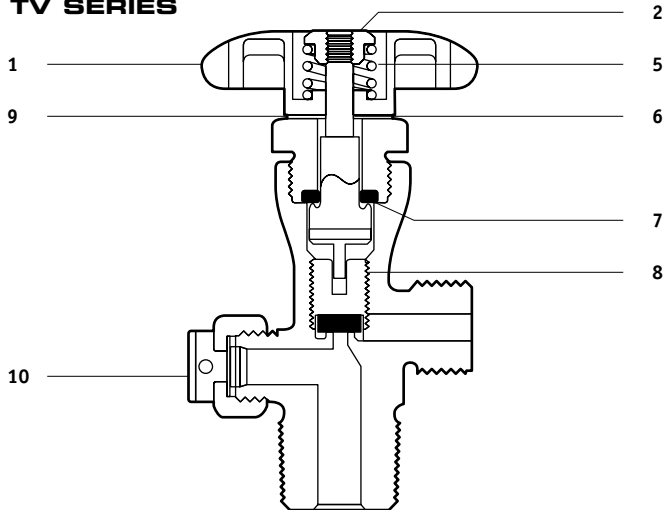

CARBON DIOXIDE & NITROGEN COMMERCIAL VALVES

All Sherwood Carbon Dioxide & Nitrogen Commercial Valves

FIG.	P/N	SERVICE & MAINTENANCE PART DESCRIPTION
N/S	PC1	Plastic Thread Protector Fits CGA-320 Outlet on Carbon Dioxide Valves
N/S	NITA	Adapter (Valve to Regulator) CGA-580 for Nitrogen Valves
N/S	C017	Nut (Valve to Regulator) CGA-320 for Carbon Dioxide Valves
N/S	C013	Nipple (Valve to Regulator) CGA-320 for Carbon Dioxide Valves
N/S	COMB	Adapter for Siphon Tube Will Not Work w/ 1/2" Valves or 50ST Siphon Tubes
N/S	15ST	Siphon Tube (21 1/8") Must Be Cut to Correct Length

Assembly Torques Packing Nut 70-80 ft-lb
Safety Assembly 30-40 ft-lb

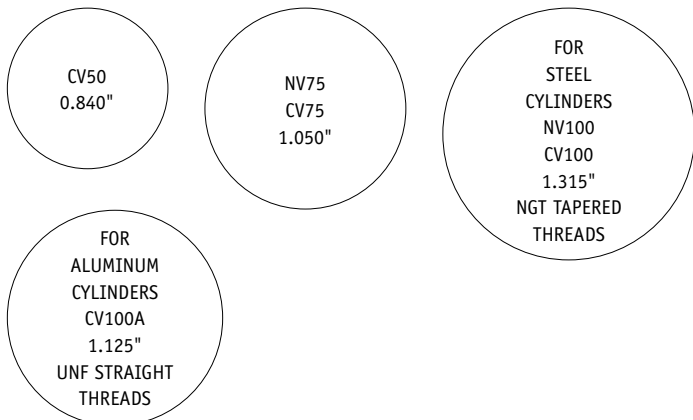

CARBON DIOXIDE & NITROGEN COMMERCIAL VALVES

Type 1100 (COM50, COM75, COM100, COM100A, NIT75, NIT100)
 Type 1200 (Older Style)

FIG.	P/N	SERVICE & MAINTENANCE PART DESCRIPTION
10	16ASV	Safety Disc Only Carbon Dioxide (For DOT 1800 Cylinders)
10	15SV	Safety Gasket
11	OR39	Collar O-Ring Type 1100 w/ Straight Threads for Aluminum Cylinders

FIG.	P/N	ACCESSORY PART DESCRIPTION
N/S	PC1	Plastic Thread Protector Fits CGA-320 Outlet on Carbon Dioxide Valves
N/S	NITA	Adapter (Valve to Regulator) CGA-580 for Nitrogen Valves
N/S	C017	Nut (Valve to Regulator) CGA-320 for Carbon Dioxide Valves
N/S	C013	Nipple (Valve to Regulator) CGA-320 for Carbon Dioxide Valves
N/S	COMB	Adapter for Siphon Tube Will Not Work w/ 1/2" Valves or 50ST Siphon Tubes
N/S	15ST	Siphon Tube (21 1/8") Must Be Cut to Correct Length

Assembly Torques Packing Nut 50 ft-lb
 Safety Assembly 35-40 ft-lb

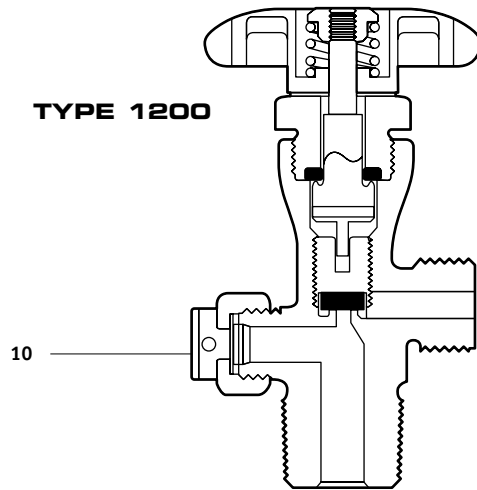
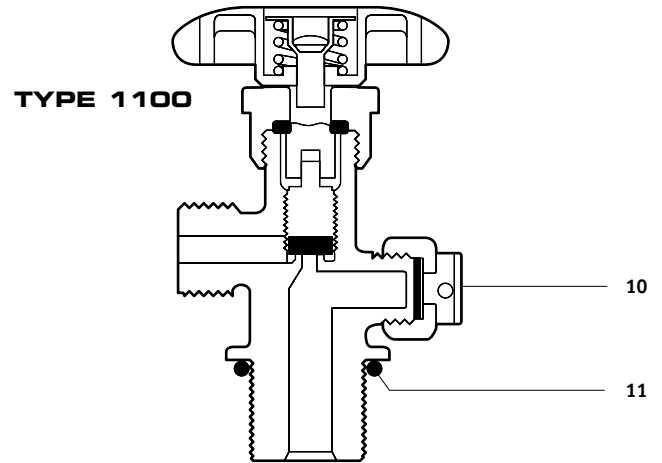

COM50
0.840"

NIT75
COM75
1.050"

FOR
STEEL
CYLINDERS
NIT100
COM100
1.315"
NGT TAPERED
THREADS

FOR
ALUMINUM
CYLINDERS
COM100A
1.125"
UNF STRAIGHT
THREADS

11 FIRE EXTINGUISHER PARTS

BUCKEYE - DRY CHEMICAL

1¹/₈" Valves 1975 to 1984 & 1¹/₄" Valves Prior to 1975

P/N	DESCRIPTION
WVS13	Valve Stem Dry Chemical 1 ¹ / ₈ " Valve
WVS15	Valve Stem Dry Chemical 1 ¹ / ₄ " Valve
700207W*	Wall Hanger
AD23	Recharge Adapter
HTA7	Hydrostatic Test Adapter

FYR-FYTER, BUFFALO, PYRENE, C-O-TWO - DRY CHEMICAL, & WATER

P/N	DESCRIPTION
G40*	Collar Gasket Dry Chemical, Water
OR24	Collar O-Ring Water
OR28	Collar O-Ring 5-20 lbs
OR34*	Collar O-Ring 20-30 lb Heavy Duty
FVS19*	Valve Stem 2M, 6M, 10M, 10H
FVS21	Valve Stem D/C & Newer Models 20S, 20M, 20H
OR30	Siphon Tube O-ring Heavy Duty
AV1	Air Valve Assembly 2 ¹ / ₂ Gal Water
109942F*	Wall Hanger 5-6 lb Dry Chemical
AD29	Recharge Adapter

GENERAL - DRY CHEMICAL

TCP-2 1/2J, KCP-2 1/2J

P/N	DESCRIPTION
G195	Gauge - 195
39622G*	Nozzle
AD24	Recharge Adapter
HTA20	Hydrostatic Test Adapter

GENERAL - WATER/LOADED STREAM

WS-900, LS-900

P/N	DESCRIPTION
G100WS	Gauge - 100
AV1	Air Valve Assembly
HTA10	Hydrostatic Test Adapter

KIDDE - DRY CHEMICAL

10-30 lb Brass Valve

P/N	DESCRIPTION
OR315	Collar O-Ring
KVS46*	Valve Stem Assembly
AD25	Recharge Adapter

KIDDE - CARBON DIOXIDE

5-20 lb Brass Valve

P/N	DESCRIPTION
KDP	Double Point Pin
260299K	Safety Disc
202208K	Wall Hanger

*WHILE QUANTITIES LAST!

PEM ALL

Small Valve 2.5 - 14 lb D/C & Halon 1211

P/N	DESCRIPTION
S4PA	Valve Stem Assembly (PA100-10)
WB1PA	Wall Hanger
AD21	Recharge Adapter
HTA21	Hydrostatic Test Adapter

POWER-PACK - DRY CHEMICAL

P/N	DESCRIPTION
RV33	Lever & Handle Rivet
OR37	Collar O-Ring
5502P	Wall Hanger 5 lb
1010P	Wall Hanger 10 lb
AD24	Recharge Adapter
HTA7	Hydrostatic Test Adapter

PYRONAUTS - DRY CHEMICAL

P/N	DESCRIPTION
RV59	Lever & Handle Rivet
OR20	Collar O-Ring
PNVS51*	Valve Stem
AD23	Recharge Adapter
HTA7	Hydrostatic Test Adapter

STOP-FIRE - DRY CHEMICAL

P/N	DESCRIPTION
OR21	Collar O-Ring HV1
OR27	Collar O-Ring HV6
OR295	Collar O-Ring HV2, HV3
OR333	Cylinder O-Ring HV2, HV3

STRIKE FIRST - DRY CHEMICAL

P/N	DESCRIPTION
SFPP	Pull Pin
RV80	Lever & Handle Rivet
OR20	Collar O-Ring (161345 Obsolete)
AD24	Recharge Adapter
HTA7	Hydrostatic Test Adapter

*WHILE QUANTITIES LAST!



12

SYSTEM PARTS

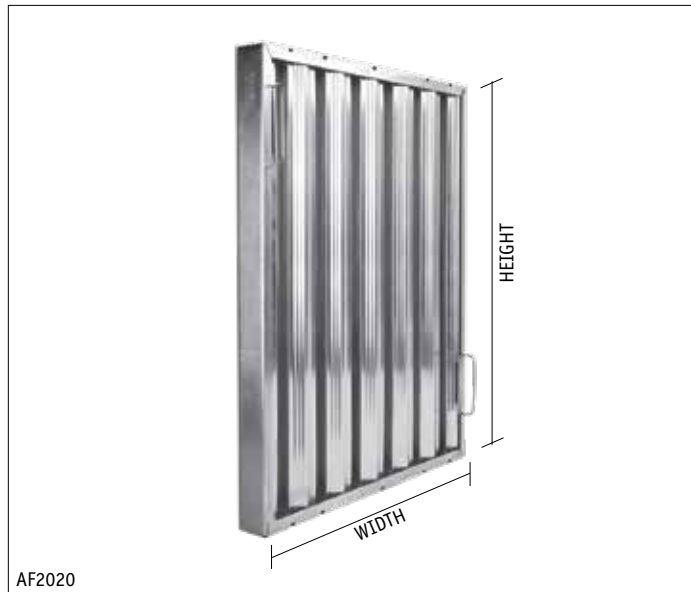

AF2020



GVF1616



LHF2020



FLH2



FP1230

HOOD FILTERS AND ACCESSORIES

ALUMINUM GREASE FILTERS are lightweight for easy handling (replace mesh filters that are no longer acceptable, per NFPA 96). Filters come standard with bale handles. UL listed.

NOTE: Actual height and width measures ⁷/₁₆" less than nominal sizes. All filters measure 1³/₄" thick.

P/N	DESCRIPTION	H X W
AF1016	Aluminum Grease Filter	10" x 16"
AF1020	Aluminum Grease Filter	10" x 20"
AF1216	Aluminum Grease Filter	12" x 16"
AF1220	Aluminum Grease Filter	12" x 20"
AF1616	Aluminum Grease Filter	16" x 16"
AF1620	Aluminum Grease Filter	16" x 20"
AF1625	Aluminum Grease Filter	16" x 25"
AF2016	Aluminum Grease Filter	20" x 16"
AF2020	Aluminum Grease Filter	20" x 20"
AF2025	Aluminum Grease Filter	20" x 25"
AF2516	Aluminum Grease Filter	25" x 16"
AF2520	Aluminum Grease Filter	25" x 20"

GALVANIZED GREASE FILTERS

P/N	DESCRIPTION	H X W
GVF1616	Galvanized Grease Filter	16" x 16"
GVF1620	Galvanized Grease Filter	16" x 20"
GVF1625	Galvanized Grease Filter	16" x 25"
GVF2016	Galvanized Grease Filter	20" x 16"
GVF2020	Galvanized Grease Filter	20" x 20"
GVF2025	Galvanized Grease Filter	20" x 25"
GVF2516	Galvanized Grease Filter	25" x 16"
GVF2520	Galvanized Grease Filter	25" x 20"

STAINLESS STEEL GREASE FILTERS

P/N	DESCRIPTION	H X W
SSF1616	Stainless Steel Grease Filter	16" x 16"
SSF1620	Stainless Steel Grease Filter	16" x 20"
SSF1625	Stainless Steel Grease Filter	16" x 25"
SSF2020	Stainless Steel Grease Filter	20" x 20"
SSF2025	Stainless Steel Grease Filter	20" x 25"
SSF2520	Stainless Steel Grease Filter	25" x 20"

Aluminum **LOCKING HANDLE GREASE FILTERS** are required in MD, VA, and Washington, D.C.

P/N	DESCRIPTION	H X W
LHF2020	Locking Grease Filter	20" x 20"
LHF2025	Locking Grease Filter	20" x 25"
LHF2520*	Locking Grease Filter	25" x 20"

*WHILE QUANTITIES LAST!

FILTER LOCKING HANDLES come complete with springs, washers, clips, and instructions. Pkg/2.

P/N	DESCRIPTION
FLH2	Filter Handles

Brooks' FRYER PANELS are made from stainless steel with deburred edges and have a large radius corner for protection. Meets NFPA 96, which requires that a plate be installed when a fryer is closer than 16" to surface flames on an adjacent appliance.

P/N	DESCRIPTION	H X W
FP1230	Fryer Panel	12" x 30"
FP1830	Fryer Panel	18" x 30"

Fill in the uncovered plenum space that results from using standard-size filters with **FireTech™ FILTER SPACERS**. They offer 20 ga 430 stainless steel construction with brushed finishes.

NOTE: Never place fusible links directly above a spacer, due to limited air flow. Actual heights are ⁷/₁₆" shorter than listed.

P/N	DESCRIPTION	H X W
FGF210	Filter Spacer	10" x 2"
FGF212	Filter Spacer	12" x 2"
FGF216	Filter Spacer	16" x 2"
FGF220	Filter Spacer	20" x 2"
FGF225	Filter Spacer	25" x 2"
FGF310	Filter Spacer	10" x 3"
FGF312	Filter Spacer	12" x 3"
FGF316	Filter Spacer	16" x 3"
FGF320	Filter Spacer	20" x 3"
FGF325	Filter Spacer	25" x 3"
FGF410	Filter Spacer	10" x 4"
FGF412	Filter Spacer	12" x 4"
FGF416	Filter Spacer	16" x 4"
FGF420	Filter Spacer	20" x 4"
FGF425	Filter Spacer	25" x 4"

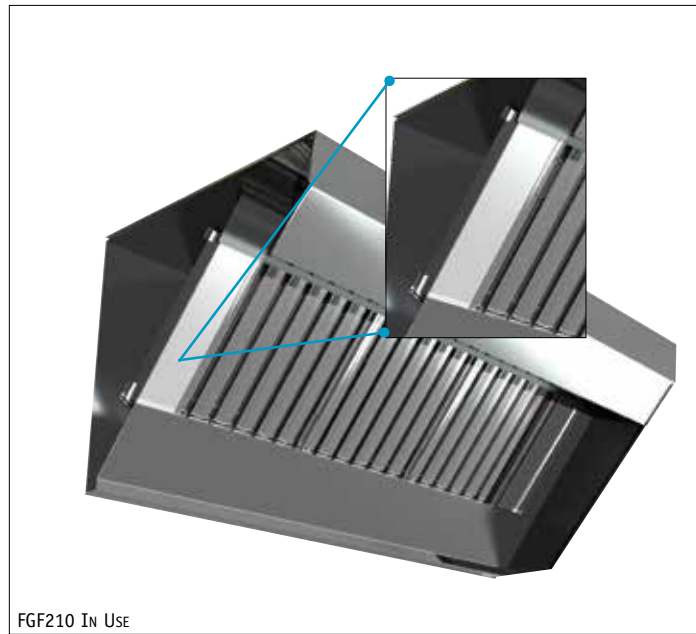

FGF210 In Use

These are complete **HOOD LIGHT FIXTURES** with 6" leads and your choice of heat-tempered globes (with or without plastic coatings). Globes will not discolor with heat.

P/N	DESCRIPTION
HLF1	Hood Light Fixture w/ Standard Globe
HLF2	Hood Light Fixture w/ Coated Globe
PCG	Replacement Globe w/ Plastic Coating
HFSG	Replacement Standard Globe w/o Plastic Coating
HLWG	Wire Guard
	For Hood Light
→ HLWG2	Wire Guard w/ Cut Opening
	For Hood Light



HLF2

HLWG2

Regin SMOKE CARTRIDGES are easy to handle, non-explosive, and great for studying exhaust air and smoke stacks or leak-testing duct work, pipelines, and tanks.

P/N	DESCRIPTION	WEIGHT	SMOKE VOL.	BURN TIME	PKG QTY
S102	Fumax	0.10 oz	150 cu ft	45 sec	10
S103	Fumax KS	0.33 oz	600 cu ft	1½ min	10
S104	Ventax	0.66 oz	1200 cu ft	3-4 min	5
S105	Brandax	2.11 oz	2500 cu ft	3-4 min	5
S107	Brandax KS	1 lb	18,000 cu ft	5-6 min	1



SMOKE CARTRIDGES

SYSTEM TEST BALLOONS are used to show the AHJ that the chemical lines are open. Pkg/25.

WARNING: Do not use for chemical discharge!

P/N	DESCRIPTION
STB25	Test Balloons



STB25 In Use



DC8GA



DU106GA



D106F2GA



D1612F2GA



DRU12814GA



D106ULBI



DR10612ULBI



FS900



HS1

Simple to install, **Ductmate® Sandwich® DUCT ACCESS DOORS** provide easy access and a leak-resistant seal to grease ducts or high-temperature duct systems. Includes stick-on template for hole cutting. All fit rectangular ducts except as noted in the description. **NOTE:** Call the Sales Department for complete specs.

P/N	DESCRIPTION	DOOR SIZE	MAX TEMP RATING
DC8GA	Circular Clean-Out	8 ³ / ₄ " Dia	200°
DU106GA	Sandwich, Non-Insulated	11" x 7"	200°
DU128GA	Sandwich, Non-Insulated	13" x 9"	200°
DI128GA	Sandwich, Insulated	13" x 9"	200°
D106F1GA	Hi-Temp	11" x 7"	1000°
D128F1GA	Hi-Temp	13" x 9"	1000°
D106F2GA	Hi-Temp Grease Duct	11" x 7"	2300°
D128F2GA	Hi-Temp Grease Duct	13" x 9"	2300°
D1814F2GA	Hi-Temp Grease Duct	19" x 15"	2300°
D1612F2GA	Hi-Temp Grease Duct	16" x 12"	2300°
DRU12814GA	Non-Insulated	12 ¹ / ₂ " x 8 ⁹ / ₁₆ "	200°
DRU161224GA	Non-Insulated	16" x 12"	200°
	For 12"-14" Round Duct		
	For 23"-24" Round Duct		

→ **More DOOR SIZES Available - Call for Pricing.**

UL 1978 listed, **Ductmate® Ultimate Door™ DUCT ACCESS DOORS** meet NFPA 96 standards and are simple to install—no welding, drilling, or special tools needed. Doors are tough, consisting of two layers of 11 ga steel and a high-temperature ceramic board (rated to 2300°). Self-adhesive templates for making duct openings are included. Stainless steel doors available too. All fit rectangular ducts except as noted in the description.

NOTE: For steel duct use only!

P/N	DESCRIPTION	DOOR SIZE	MAX TEMP RATING
D106ULBI	Ultimate Door	10" x 6"	2300°
D1010ULBI	Ultimate Door	10" x 10"	2300°
D128ULBI	Ultimate Door	12" x 8"	2300°
D1814ULBI	Ultimate Door	18" x 14"	2300°
DR10612ULBI	Ultimate Door	12" x 8"	2300°
DR12812ULBI	Ultimate Door	14" x 10"	2300°

Flame•Safe's FIRESTOP CAULK seals penetrations in fire walls and is UL classified under "Fill or Cavity Materials." It produces a sandable, paintable surface with up to a three-hour fire rating. Water based (no solvents or silicones). 10.3 oz tube. Red.

WARNING: Not for hood use!

P/N	DESCRIPTION
FS900	Firestop Caulk Data Sheet Online at BrooksEquipment.com

Made of 100% silicone, this **HOOD CAULK** can be applied overhead (up to 400°F) and meets federal and NSF standards for food service use. 10.3 oz tube. Gray (aluminum color).

NOTE: Does not meet NFPA requirements for sealing hood penetrations.

P/N	DESCRIPTION
HS1	Hood Caulk

SAFETY-SET BRACKETS are designed to precisely relocate mobile cooking equipment under the exhaust hood, at the approved designed location, in accordance with NFPA 96 and NFPA 17A requirements. Each pair of **Safety-Set Brackets** include installation hardware.

P/N	DESCRIPTION
PS2	Safety-Set Brackets



PS2 In Use

This plastic **FireTech™ GREASE COMB** accurately measures the amount of grease buildup on hoods, fans, ducts, and other surfaces using depth-gauge teeth (clearly printed in microns). White.

P/N	DESCRIPTION	L X H X W
FTGC	Grease Comb	6" x 2 ⁵ / ₁₆ " x 7/ ₈ "

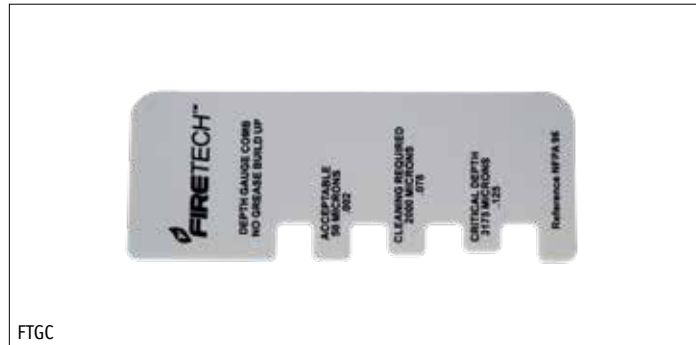

FTGC

Brooks' biodegradable **STAINLESS STEEL CLEANER/POLISH** is a clear thin liquid with a pleasant smell. It does not contain harsh ingredients nor will it harm skin or metal surfaces (when used as directed). Perfect for use in restaurants and other buildings with stainless steel, brass, or bronze surfaces.

P/N	DESCRIPTION
BRSSPQ	Stainless Steel Cleaner/Polish, 1 qt
BRSSPG	Stainless Steel Cleaner/Polish, 1 gal



BRSSPQ

BRSSPG

Sheila Shine STAINLESS STEEL CLEANER/POLISHER removes grease film and finger marks and covers scratches, leaving a protective coating that preserves surfaces.

NOTE: Low VOC formula versions comply with CARB regulations and are suitable for sale and distribution in California.

P/N	DESCRIPTION
SSCPA	Stainless Steel Cleaner/Polish, 10 oz Aerosol
SSCPQ	Stainless Steel Cleaner/Polish, 1 qt
SSCPG	Stainless Steel Cleaner/Polish, 1 gal
SSCA10	Stainless Steel Cleaner/Polish (Low VOC Formula), 10 oz Aerosol
SSCA32	Stainless Steel Cleaner/Polish (Low VOC Formula), 1 qt
SSCA128	Stainless Steel Cleaner/Polish (Low VOC Formula), 1 gal



SSCPG

COMMERCIAL APPLIANCE CLEANERS include **Grease Out**, which safely removes carbonized soils and greases from grills and oven surfaces. **Slash** oven, grill, and fryer cleaner handles moderately soiled stovetops, burners, griddles, and deep fryers. For the really tough jobs, **Blast** thickened oven cleaner cuts through grease, fats, and burnt-on foods in ovens and on ranges, range hoods, vents, grills, and broilers.

NOTE: Not for use on soft metals. For shipping, SLASH1 and BLAST1 must be sold in case quantity of four.

P/N	DESCRIPTION
OCA18	Grease Out Oven Cleaner, 18 oz Aerosol, Pkg/12
SLASH1	Slash Oven, Grill, & Fryer Cleaner, 1 gal, Pkg/4
BLAST1	Blast Oven Cleaner & Degreaser, 1 gal, Pkg/4



OCA18

SLASH1



KCW180



KCHWM w/ KCHDW475 In Use



KCHDD w/ KCHDW475 In Use



KCST55

WIPERS AND DISPENSERS

WypAll® WIPERS provide better absorption than shop rags and come in different thicknesses for different jobs. Using **Hydroknit®** technology, they combine excellent absorbing power in a lightweight wiper that takes up less space than rags. The **JUMBO ROLL DISPENSER** makes dispensing wipers easy.

P/N	DESCRIPTION
KCW180	Brag Box Wipers, 12 ¹ / ₂ " x 16 ³ / ₄ ", White, Box/180 Replaces 25 lb of Scrap Rags
KCHDW475	Jumbo Roll Wipers, 12 ¹ / ₂ " x 13 ³ / ₈ ", Red, Roll/475 Replaces 75 lb of Scrap Rags
KCHDD	Jumbo Roll Dispenser, 16 ³ / ₄ "L x 33"H x 18 ¹ / ₂ "W
KCHWM	Jumbo Roll Wall Mount Dispenser, 16 ³ / ₄ "L x 8 ³ / ₄ "H x 10 ³ / ₄ "W

Scott® SHOP TOWELS are strong, soft, and absorbent and work like cloths. They are great for wiping hands and cleaning tools and easily absorb liquids, oil, and grease. They fit on standard towel holders for convenient dispensing. 10³/₈" x 11" sheets. Blue. Roll/55.

P/N	DESCRIPTION
KCST55	Shop Towels



KCRB200

Scott® RAGS IN A BOX are specifically designed for hands-on work. These soft, absorbent towels perform with the strength, durability, and absorbency of a cloth and come in a convenient **Pop-Up Box** with a built-in handle for easy transport. 10" x 13" sheets. White. Box/200.

P/N	DESCRIPTION
KCRB200	Rags In A Box



PS1003

PROTECTIVE EQUIPMENT

Clear **PLASTIC SHEETING** is ideal for keeping appliances protected from dirt, grime, and chemicals. Dispensed from a 4' roll.

P/N	DESCRIPTION
PS1003	Plastic Sheeting, 12' x 100', 3 mil
PS10015	Plastic Sheeting, 16' x 100', 1.5 mil

These economical **SAFETY GOGGLES** feature a comfortable, soft frame; direct ventilation; and a wide, one-piece polycarbonate lens. Meets ANSI Z87.1+ requirements. 99.9% UV protection. Clear frame, clear lens.

P/N	DESCRIPTION
EW201	Safety Goggles



EW201

Ergonomically designed and multi-dipped, **Black Jack® NEOPRENE GLOVES**, from **MCR**, create a liquid-proof barrier against abrasions and chemicals. Gloves have gauntlet cuffs, brushed-cotton interlock linings, and an etched rough finish. Large. FDA compliant. Black.

P/N	DESCRIPTION
MG6932	Neoprene Gloves, 12" Gauntlet
MG6944	Neoprene Foam-Lined Gloves, 14" Gauntlet



MG6932

PROTECTIVE COVERALLS come with open wrists and ankles, serged seams, and a front zipper and collar.

P/N	DESCRIPTION	SIZE
555L	Coveralls, White	LG
555XL	Coveralls, White	XL
555XXL	Coveralls, White	2XL
TYBC	18" Boot Covers, Non-Skid, Gray	Universal



TYBC In Use



555L

MCR's 15" STEEL TOE PVC BOOTS feature a heavy-duty over-the-sock design and cleated soles with traction grips. Flexible and 100% waterproof, with polyester linings and kick-off lugs for easy on/off, they offer excellent comfort and abrasion resistance. Steel toe meets ASTM 2412 and ASTM 2413 specifications. Black.

P/N	DESCRIPTION	SIZE
STB10	15" PVC Boots	10
STB11	15" PVC Boots	11
STB12	15" PVC Boots	12
STB13	15" PVC Boots	13
STB14	15" PVC Boots	14



STB10

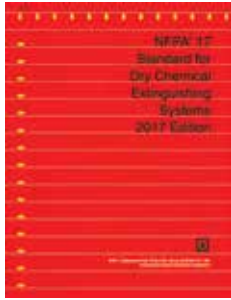

NFPA1717



IT525



G16524PHL



G165ETL



CODES AND REGULATIONS

For nearly a century, people have relied on **NFPA® PUBLICATIONS**—your blueprints to safety.

P/N	DESCRIPTION
NFPA1717	NFPA 17: Standard for Dry Chemical Extinguishing Systems, 2017 ed
NFPA17A17	NFPA 17A: Standard for Wet Chemical Extinguishing Systems, 2017 ed
NFPA9617	NFPA 96: Standard for Ventilation Control & Fire Protection of Commercial Cooking Operations, 2017 ed

For other NFPA Publications, See Page 60

Raytek's MiniTemp® INFRARED LASER THERMOMETER

measures surface temperatures, identifying potential problems before they start. Or, as in the case of fusible links, it demonstrates the temperature at which they may activate. Safe, fast, and contamination-free, its infrared technology provides nearly instantaneous readings without actually touching an object.

MiniTemp is small enough to fit in your pocket and includes a backlit display for easy viewing and a laser point to pinpoint your target.

SPECIFICATIONS

Temperature Range: 0°F to 750°F
 Max. Target (Spot) Distance: 4'
 Optical Resolution (D:S): 8:1
 Accuracy (+/- 2% or +/- 2°C (+/- 3°F) of reading, whichever is greater)
 Sighting: Laser Point
 Emissivity: Pre-Set to 0.95

P/N	DESCRIPTION
IT525	Laser Thermometer

FUSIBLE LINKS AND HEAT DETECTORS

PHL Links™ McCabe® RESETTABLE BI-METAL FIRE LINKS are UL 33 permanent replacements for fusible links.

Utilizing a corrosion-resistant, bi-metal configuration, **McCabe Links** are resettable and reusable (after testing), making them environmentally friendly and cost effective. Load range 1–25 lb.

P/N	DESCRIPTION
G16524PHL	McCabe 165°F Thermal Electric Link, 24 VDC Link w/ 55 W Electric Heater
G21224PHL	McCabe 212°F, 24 VDC/2.3 A Link w/ 55 W Electric Heater
G212120PHL	McCabe 212°F, 120 VAC/0.46 A Link w/ 55 W Electric Heater
GUB165PHL	McCabe 165°F Reusable Link w/ Grommet Universal Link Base

SR ELECTRO THERMAL LINK (ETL) is a UL listed, dual-responsive fusible link and release device designed to substantially improve life safety and minimize property damage. It creates an instantaneous fusible link response and separation in the event of fire. The **ETL** has a protruding cylinder to house the heating element and attachment wires, and it provides a means to attach a standard EMT conduit connector adapter. Load range 2–40 lb.

P/N	DESCRIPTION
G165ETL	ETL 165° Fusible Link/Release Device

Globe MODEL K FUSIBLE LINKS are UL listed and UL classified for use with extinguishing systems. Load range 3–50 lb.
NOTE: Order in bags of 20 to receive UL classified links with cross reference chart.

P/N	DESCRIPTION
G165K	165°F Model K Link
G212K	212°F Model K Link
G280K	280°F Model K Link
G360K	360°F Model K Link
G450K	450°F Model K Link

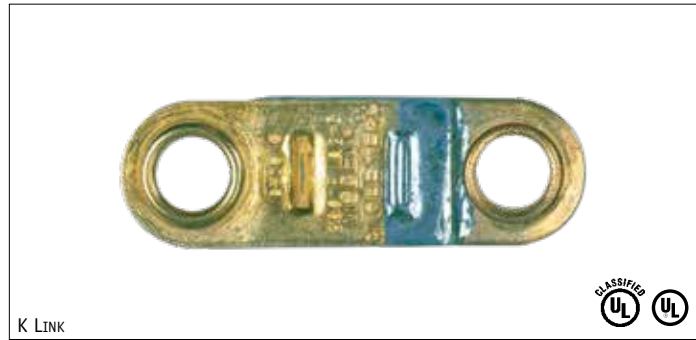

Globe MODEL ML FUSIBLE LINKS are UL listed and UL classified for use with extinguishing systems. Load range 10–40 lb.
NOTE: Order in bags of 20 to receive UL classified links with cross reference chart.

P/N	DESCRIPTION
G135ML	135°F Model ML Link
G165ML	165°F Model ML Link
G212ML	212°F Model ML Link
G280ML	280°F Model ML Link
G360ML	360°F Model ML Link
G450ML	450°F Model ML Link
G500ML	500°F Model ML Link



Globe MODEL A FUSIBLE LINKS are UL listed, and the **G360A** is UL classified for use with extinguishing systems. Load range 3–45 lb.
NOTE: Order the G360A in bags of 20 to receive UL classified links with cross reference chart.

P/N	DESCRIPTION
G165A	165°F Model A Link
G212A	212°F Model A Link
G280A	280°F Model A Link
G360A	360°F Model A Link
G450A	450°F Model A Link



Globe MODEL B FUSIBLE LINKS are UL listed and FM approved for use with extinguishing systems. Load range 3–20 lb.

P/N	DESCRIPTION
G135B	135°F Model B Link
G165B	165°F Model B Link
G212B	212°F Model B Link
G280B	280°F Model B Link
G360B	360°F Model B Link



TEST LINKS are used in place of more expensive fusible links for testing detection lines. They are the same size as **Globe Model ML**, **K**, and **B** links. Pkg/10.

P/N	DESCRIPTION
GTL1	Test Links



Fusible links used in cooking operations should be replaced during semi-annual maintenance, unless conditions require more frequent replacement. To verify that proper maintenance has been performed, write the date of installation and the date of the fusible link on the inspection tag.

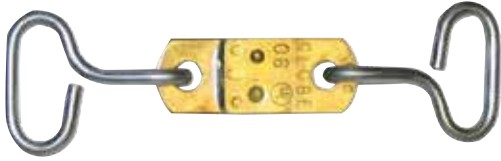

JS LINK



Globe MODEL JS FUSIBLE LINKS are specifically designed for standard-type fire dampers and have a load range of 3–10 lb. UL listed.

P/N	DESCRIPTION
G165JS	165°F Model JS Link
G212JS	212°F Model JS Link

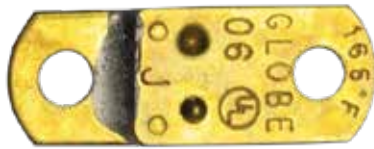

J LINK



Globe MODEL J FUSIBLE LINKS are heat activated and made with brass components to resist corrosion. They have a high-strength symmetrical shape with a load range of 3–10 lb. UL listed.

P/N	DESCRIPTION
G165J	165°F Model J Link
G212J	212°F Model J Link



D LINK



Globe MODEL D FUSIBLE LINK is UL listed with a load range of 1–8 lb.

P/N	DESCRIPTION
G165D	165°F Model D Link



ET194

Thermotech HEAT DETECTORS are normally open devices designed specifically for fire detection and alarm systems. These rate-compensation-type detectors are available with 135°F or 194°F ratings. All are self-restoring, hermetically sealed, shock and corrosion resistant, as well as tamperproof. Approvals/Listings: UL, FM (except for **EPM194**), California State Fire Marshal Listing No. 7270 0021:001, and New York City Department of Buildings, MEA 193-03-E.

NOTE: Not for use in direct sunlight. Explosion-proof model EPM194 for indoor use only. Refer to NFPA 72 for application requirements, testing, and maintenance.

P/N	DESCRIPTION
ET135	135°F All-Weather Heat Detector
ET194	194°F All-Weather Heat Detector
EPM194	194°F Explosion-Proof Heat Detector

FUSIBLE LINK BRACKETS AND CONDUIT FITTINGS

This **10" FUSIBLE LINK BRACKET** is UL classified for use in **Pyro-Chem®** and **Range Guard®** systems, per NFPA 17 and 17A.

P/N	DESCRIPTION
LBK1	10" Link Bracket



LBK1

Offering better air flow around fusible links, this **10" HIGH STAND OFF FUSIBLE LINK BRACKET** is UL classified for use in **Pyro-Chem®** and **Range Guard®** systems, per NFPA 17 and 17A. It will match up to a **CP5** when coming through the top of a hood with a **GSA12**.

P/N	DESCRIPTION
LBK3	10" High Stand Off Link Bracket



LBK3

This **8" FUSIBLE LINK BRACKET** is UL classified for use in **Kidde** systems, per NFPA 17 and 17A.

P/N	DESCRIPTION
LBK2	8" Link Bracket



LBK2

Facilitating the attachment of an **Ansul®** or **Pyro-Chem®** large-threaded corner pulley to an **LBK3** fusible link bracket, this **LINK HOUSING ADAPTER KIT** reduces the larger threads of the corner pulley to fit the smaller-diameter link bracket hole. No conduit or conduit fittings are required either. Kit comes with (1) reducing adapter and (1) steel nut.

P/N	DESCRIPTION
LHAK	Link Housing Adapter Kit

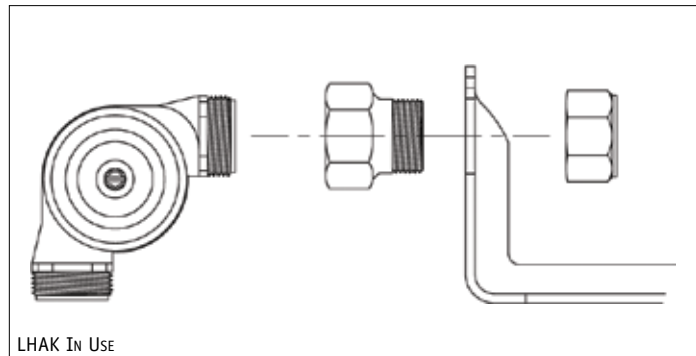

LHAK In Use

These **500°F TEMPERATURE LABELS** feature dots that turn black when the required temperature is reached, indicating the links are reacting as designed. Labels are 1/2" square with a 1/4" dot center. Card/21.

P/N	DESCRIPTION
BL500	Temperature Labels



BL500



500C16

CABLE, CRIMPS, AND S-HOOKS

FireTech™ aircraft-type 7 x 7 **STAINLESS STEEL CABLE** is for automatic suppression systems.

P/N	DESCRIPTION
1000C16	1/16" x 1000', Stainless Steel Cable
500C16	1/16" x 500', Stainless Steel Cable
250C16	1/16" x 250', Stainless Steel Cable
50C16	1/16" x 50', Stainless Steel Cable
250C64	3/64" x 250', Stainless Steel Cable

CRIMPS and **S-HOOKS** are for automatic suppression systems.

P/N	DESCRIPTION
OS1	3/64" Oval Zinc-Plated Copper Crimps, Pkg/100
OS2	1/16" Oval Zinc-Plated Copper Crimps, Pkg/100
OS3	1/16" Copper Stop Crimps, Pkg/100
OS4	1/16" Kidde-Style Plated Copper Crimps, Pkg/100
BHN	Brass Hex Nut
SHK	1" S-Hooks, Pkg/100

These **CABLE CUTTERS** leave clean square cuts on stainless steel cable, while their cadmium-plated, heat-treated alloy construction ensures maximum rust prevention and durability.

NOTE: Do not use on S-Hooks or Links!

P/N	DESCRIPTION
CC093	6" Cable Cutters

Made of aircraft-quality alloy steel, these **CRIMPING TOOLS** feature thick, comfortable vinyl handles for all-day use.

P/N	DESCRIPTION
ST116	8" Crimping Tool For 1/16" Copper Oval & Stop Sleeves
ST364	8" Crimping Tool For 3/64" Copper Oval & Stop Sleeves

EMT CONDUIT FITTINGS

P/N	DESCRIPTION
1210	1/2" EMT Set Screw Connectors, Pkg/50
1220	1/2" EMT Set Screw Couplings, Pkg/50
2105	1/2" EMT Compression Connectors, Pkg/50
2205	1/2" EMT Compression Couplings, Pkg/50
1505	1/2" EMT & 3/8" Pipe Single Hole Straps, Pkg/100
7800	Standoff Clamps w/ Bolts, Pkg/100 For 1/2" EMT, 1/2", & 3/8" Pipe
6515	1/2" Steel Compression Connector
2232	1/2" Steel EMT Fitting For Hood Seals/Link Brackets (Will Screw into QSA2)



OS1, OS2



OS3



OS4



BHN



SHK

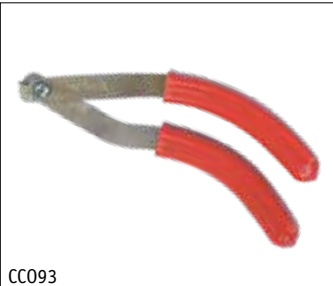

CC093



ST364



1210



1220



2105



2205



1505



7800



6515



2232

“GREASE-TITE” ADAPTERS

Featuring chrome-plated steel construction, **Jiffy THREADED “GREASE-TITE” ADAPTERS** are UL listed and conform to NFPA 96 requirements.

P/N	DESCRIPTION	H SIZE	P SIZE
QSA1	Pipe Adapter	7/8"	3/8"
QSA38	Pipe Adapter	1 1/8"	3/8"
QSA2	Pipe & Rigid Conduit	1 1/8"	1/2"
QSA3	Pipe Adapter	1 3/8"	3/4"
QSA4	Pipe Adapter	1 5/8"	1"
QSA5	Pipe Adapter	7/8"	1/4"

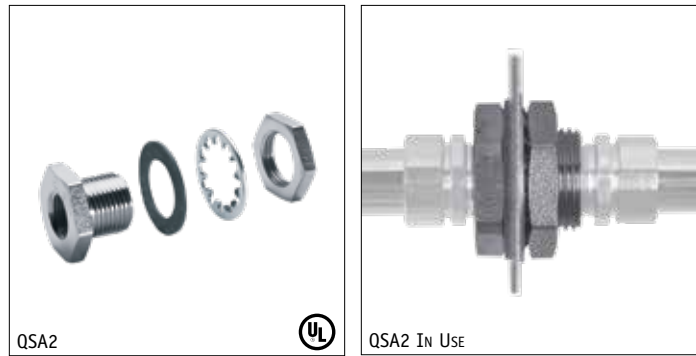

COMPRESSION “GREASE-TITE” ADAPTERS are UL listed and conform to NFPA 96 requirements and provide a grease-tight seal without welding.

P/N	DESCRIPTION	H SIZE	P SIZE
QSA8	Pipe Adapter	1 1/8"	3/8"
QSA9	EMT/Conduit Adapter	1 1/8"	1/2"
QSA10	Pipe Adapter	1 1/8"	1/2"
QSA11	Pipe Adapter	1 3/8"	3/4"



UL listed **Jiffy PATCH “GREASE-TITE” SEALS** cover unwanted holes without welding and conform to NFPA 96 requirements.

P/N	DESCRIPTION	H SIZE
QP1	Patch Seal	1 1/8"–1 1/4"
QP2	Patch Seal	7/8"–1"
QP3	Patch Seal	1 5/8"–1 3/4"
QP4	Patch Seal	1 3/8"–1 1/2"



Jiffy CORNER PULLEY “GREASE-TITE” ADAPTERS screw directly onto corner pulleys, for a quick 90° turn, when coming through the top of a hood. UL listed.

P/N	DESCRIPTION	H SIZE
QSA12	Corner Pulley Adapter <i>Fits CP5 Corner Pulley</i>	1 1/8"
QSA13	Corner Pulley Adapter <i>Fits Ansul, Pyro-Chem Corner Pulleys</i>	1 1/8"



BLIND COMPRESSION “GREASE-TITE” ADAPTERS are UL listed and conform to NFPA 96, 17, & 17A requirements. They can be installed without accessing the back of the hood to tighten their nuts. These are an excellent choice for tight hood installations with little access.

P/N	DESCRIPTION	H SIZE
QSA15	Pipe Adapter, 1/4" Tube Size	1 1/8"
QSA16	EMT/Conduit Adapter, 1/2" EMT	1 1/8"
QSA17	Pipe Adapter, 3/8" Pipe Size	1 1/8"



In Use photos may show items not included or available separately.

Ansul® and Pyro-Chem® are registered marks of Tyco Fire Products LP.

Fits Where Sockets Won't!



TL1218



TL1228 In Use

Jiffy Seal RATCHETING WRENCHES are ingenious tools that tighten/loosen hex nuts and bodies in ventilation hoods. Their unique design fits into tight spaces easily and works with any $\frac{3}{8}$ " drive flexible T-handle. Made of heat-treated steel with carbonitride/zinc plating, they automatically find the right slot angle and index to the next position when in use. **Wrenches** and **driver** sold separately.

P/N	DESCRIPTION
TL388	1 $\frac{1}{2}$ " Ratcheting Wrench For $\frac{3}{8}$ " & $\frac{1}{2}$ " Penetration Seals w/ $\frac{1}{8}$ " Hole
TL1218	1 $\frac{1}{4}$ " Ratcheting Wrench For $\frac{3}{8}$ " & $\frac{1}{2}$ " Penetration Seals w/ $\frac{7}{8}$ " Hole
TL1228	$\frac{3}{8}$ " Drive Flexible T-Handle



QMT00L



QMT00LM



QMS, QMT

Quick Mount FASTENERS and **INSTALLATION TOOLS** are for hood penetration. Per NFPA 96, any penetrations in the hood exterior are to be sealed with a listed device or by a liquid-tight, continuous external weld. The **QMT (Quick Mount Fastener)** is UL listed for mounting hardware in the hood or duct and meet code without welding. To install: drill hole with **QDRILL**, insert **QMT**, and clinch it with **QMT00L** or **QMT00LM**. **QMS** screws are ideal for mounting fusible link brackets, using the installed **QMT**.

P/N	DESCRIPTION
QMT	Quick Mount Fasteners, Pkg/10
QMS	$\frac{1}{4}$ "-20 Screws, Pkg/100 For QMT
QMT00L	Lever-Type Installation Tool
QMTA	Replacement Arbor For QMT00L
QMT00LM	Wrench-Type Installation Tool
QDRILL	Quick Mount Cobalt Drill Bit, Size "Q"



GTF1



TL1395



1399DB

Jiffy "GREASE-TITE" SEAL FASTENERS are UL listed and conform to NFPA 96 requirements. Designed for fastening items to hoods and plenums in a kitchen ventilation system, they combine thread-producing features with a high-temperature thread-jamming coating. The friction from installing them activates the thread jammers, ensuring a grease-tight seal every time. They come with a **Double Ended 1/8" Pilot Drill Bit** (with a 135° split point design) for drilling through stainless steel. The **10 mm Magnetic Driver** is used with most drills to drive screws into $\frac{1}{8}$ " pilot holes.

P/N	DESCRIPTION
GTF1	Grease-Tite Seal Fasteners, Pkg/24
TL1395	10 mm Magnetic Power Driver For Grease-Tite Fasteners
1399DB	Double Ended $\frac{1}{8}$ " Pilot Drill Bit

A **Brooks** exclusive, this **EMT FITTING** is custom made to fit **Jiffy "Grease-Tite"** 1/2" pipe-threaded adapters quickly, easily, and without force. Since a zinc diecast fitting can melt (when there is a fire), this zinc-plated steel fitting is a better choice, inside of a hood to guard against failure (due to high heat), helping to ensure proper fire suppression system operation.

P/N	DESCRIPTION
2232	1/2" EMT Fitting For Hood Seals/Link Brackets (Screws into QSA2)



2232

BROOKS CORNER PULLEYS

Brooks' high-temperature ball bearing **COMPRESSION CORNER PULLEY** is UL listed with the **Amerex®** system and UL classified for **Ansul®, Kidde, Pyro-Chem®, and Range Guard®** systems, per NFPA 17 and 17A. Its steel compression nuts eliminate thread stripping, and it has more threads than most for a stronger, easier-to-install corner pulley. Its ball bearing roller is pressed into place and stays when you remove the cover.

P/N	DESCRIPTION
CP5	Compression Corner Pulley



CP5

Brooks' high-temperature **SET SCREW CORNER PULLEY** comes with a ball bearing roller.

P/N	DESCRIPTION
CP8	Set Screw Corner Pulley



CP8

Brooks' low-temperature **SWING COVER CORNER PULLEYS.**

P/N	DESCRIPTION
CP2	Swing Cover Corner Pulley
CP6	Swing Cover Conduit Corner Pulley
CP7	Swing Cover 1/2" Threaded Corner Pulley, NPT



CP6



CP7

Brooks' **3-WAY CORNER PULLEY** comes with dual rollers.

P/N	DESCRIPTION
CP3	3-Way Corner Pulley



CP2



CP3



AX12309



AX12506

OEM CORNER PULLEYS**Amerex® CORNER PULLEYS.**

P/N	DESCRIPTION
AX12309	Amerex Corner Pulley
AX12506	Amerex Tee Pulley



A423250



A427929

Ansul® CORNER PULLEYS.

P/N	DESCRIPTION
A423250	Ansul Corner Pulley
A415670	Ansul Set Screw Corner Pulley
A427929	Ansul Tee Pulley



B843792



K844648

Badger™ Range Guard® CORNER PULLEYS.

P/N	DESCRIPTION
B844648	Badger Corner Pulley
B843792	Badger Tee Pulley

Kidde CORNER PULLEYS.

P/N	DESCRIPTION
K844648	Kidde Compression Corner Pulley
K843792	Kidde Tee Pulley

Pyro-Chem® CORNER PULLEYS.

P/N	DESCRIPTION
PC423250	Pyro-Chem Compression Corner Pulley
PC415670	Pyro-Chem Set Screw Corner Pulley
PC427929	Pyro-Chem Tee Pulley

These heavy-duty **TUBING CUTTERS** come with hardened steel reamers and spare cutting wheels.



ITC1000



1000TC

P/N	DESCRIPTION
ITC1000	Tubing Cutter
1000TC	Tubing Cutter (Domestic)
TCB	Tube Cutter Blades, Pkg/2

CHROME SLEEVING

High-luster **CHROME SLEEVING** is made of 22 ga steel (minimum). (**CS25** is the actual chrome conduit size, so there is no need for sleeving.)

P/N	DESCRIPTION
CS25	6' x 1/2" Chrome Conduit
CS38	6' Chrome Sleeving For 3/8" Pipe
CS50	6' Chrome Sleeving For 1/2" Pipe
CS75	6' Chrome Sleeving For 3/4" Pipe
CS100	6' Chrome Sleeving For 1" Pipe

Designed to make installations of conduit and pipe neat and rigid, these **STAND OFF BRACKETS** feature zinc-plated 16 ga steel construction, making pipe installations neat and rigid (pipes will not move). Conduit brackets line up to link bracket holes as indicated. Available in low- and high-profile versions. Box/25.

P/N	DESCRIPTION	A	B
SBC05	Stand Off Brackets For 1/2" Conduit (Compatible w/ Ansul, Amerex, Buckeye, Pyro-Chem, & LBK3)	2 5/8"	1 7/8"
SBC20	Stand Off Brackets For 1/2" Conduit (Compatible w/ Range Guard & Kidde)	3 1/4"	2 1/2"
SBP10	Stand Off Brackets, Low Profile For 3/8" Pipe	2 1/4"	1 1/2"
SBP38	Stand Off Brackets, High Profile For 3/8" Pipe	3 1/4"	2 1/2"
SBP15	Stand Off Brackets, Low Profile For 1/2" Pipe	2 5/8"	1 7/8"
SBP25	Stand Off Brackets, High Profile For 1/2" Pipe	3 1/4"	2 1/2"

A= OVERALL HEIGHT OF BRACKET
B= TO CENTER OF HOLE

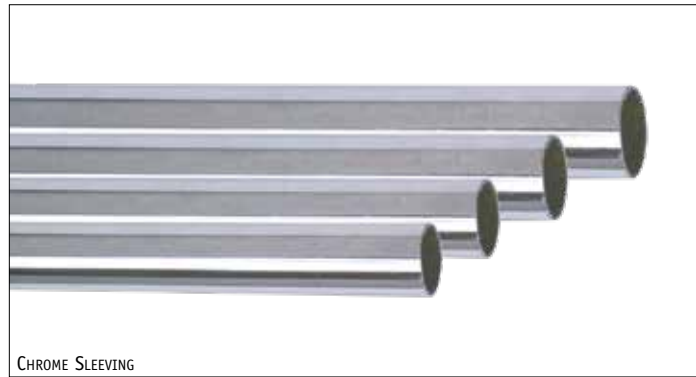

CHROME SLEEVING

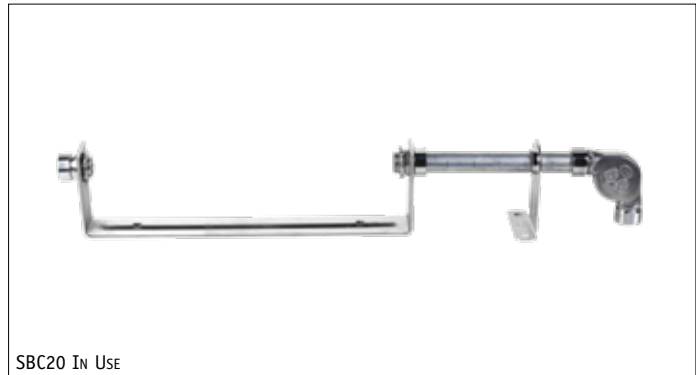

SBC20 IN USE



SBP15 IN USE



SBP25 IN USE

PIPE NIPPLES

Strong yet lightweight, the **FireTech™ NIPPLE TOTE BOX** holds 3/8" and 1/2" nipples (close—6") and features a fold-away handle for easy storage. Made of 18 ga steel with a red enamel finish and 77 compartments. Measures 10 5/8"L x 6 1/2"H x 7 3/8"W. Red.

P/N	DESCRIPTION
PNT1	Nipple Tote Box



PNT1 IN USE

In Use photos may show items not included or available separately.

Ansul® and Pyro-Chem® are registered marks of Tyco Fire Products LP.

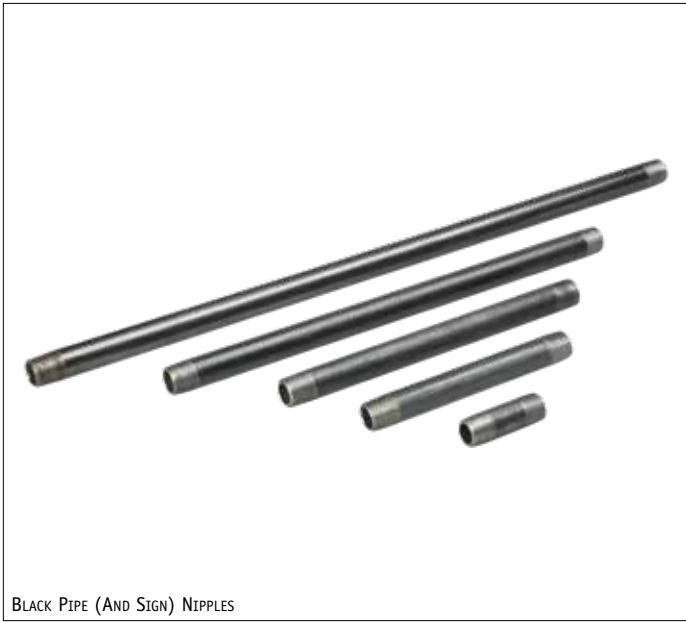

BLACK PIPE (AND SIGN) NIPPLES

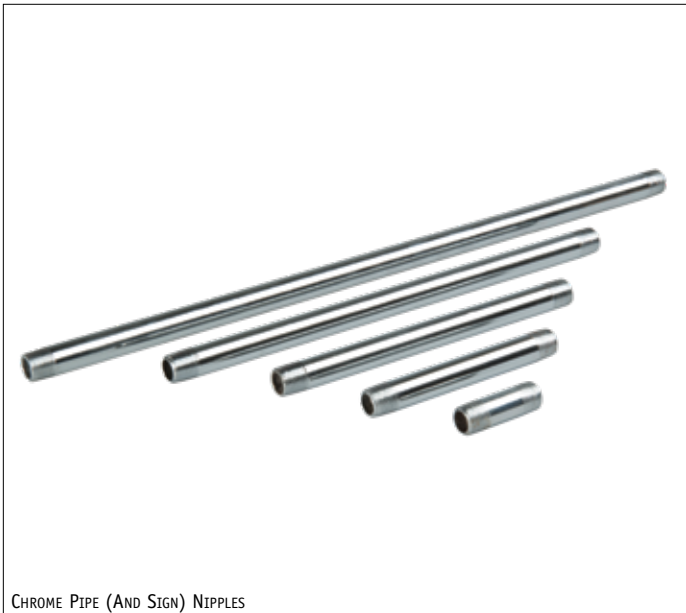

CHROME PIPE (AND SIGN) NIPPLES



N388410

$\frac{1}{8}$ " and $\frac{1}{4}$ " **BLACK PIPE NIPPLES** are threaded on both ends. Box/25 (priced each).

P/N	DESCRIPTION
N1800	$\frac{1}{8}$ " Close Black Pipe Nipples
N2500	$\frac{1}{4}$ " Close Black Pipe Nipples
N2515	$\frac{1}{4}$ " x $1\frac{1}{2}$ " Black Pipe Nipples
N2520	$\frac{1}{4}$ " x 2" Black Pipe Nipples
N2525	$\frac{1}{4}$ " x $2\frac{1}{2}$ " Black Pipe Nipples
N2530	$\frac{1}{4}$ " x 3" Black Pipe Nipples
N2540	$\frac{1}{4}$ " x 4" Black Pipe Nipples
N2550	$\frac{1}{4}$ " x 5" Black Pipe Nipples
N2560	$\frac{1}{4}$ " x 6" Black Pipe Nipples

$\frac{3}{8}$ " **BLACK** and $\frac{3}{8}$ " **CHROME PIPE** and **NIPPLES** are threaded on both ends. Box/25 (up to 12"); Box/10 (over 12"). Priced each.

BLACK PIPE NIPPLES

P/N	DESCRIPTION
N3800	$\frac{3}{8}$ " Close
N3815	$\frac{3}{8}$ " x $1\frac{1}{2}$ "
N3820	$\frac{3}{8}$ " x 2"
N3825	$\frac{3}{8}$ " x $2\frac{1}{2}$ "
N3830	$\frac{3}{8}$ " x 3"
N3835	$\frac{3}{8}$ " x $3\frac{1}{2}$ "
N3840	$\frac{3}{8}$ " x 4"
N3845	$\frac{3}{8}$ " x $4\frac{1}{2}$ "
N3850	$\frac{3}{8}$ " x 5"
N3855	$\frac{3}{8}$ " x $5\frac{1}{2}$ "
N3860	$\frac{3}{8}$ " x 6"
N3880	$\frac{3}{8}$ " x 8"
N3810	$\frac{3}{8}$ " x 10"
N3812	$\frac{3}{8}$ " x 12"

BLACK PIPES

P/N	DESCRIPTION
N3814	$\frac{3}{8}$ " x 14"
N3816	$\frac{3}{8}$ " x 16"
N3818	$\frac{3}{8}$ " x 18"
N3824	$\frac{3}{8}$ " x 24"
N38300	$\frac{3}{8}$ " x 30"
N3836	$\frac{3}{8}$ " x 36"
N3848	$\frac{3}{8}$ " x 48"

CHROME PIPE NIPPLES

P/N	DESCRIPTION
CRN3800	$\frac{3}{8}$ " Close
CRN3815	$\frac{3}{8}$ " x $1\frac{1}{2}$ "
CRN3820	$\frac{3}{8}$ " x 2"
CRN3825	$\frac{3}{8}$ " x $2\frac{1}{2}$ "
CRN3830	$\frac{3}{8}$ " x 3"
CRN3835	$\frac{3}{8}$ " x $3\frac{1}{2}$ "
CRN3840	$\frac{3}{8}$ " x 4"
CRN3845	$\frac{3}{8}$ " x $4\frac{1}{2}$ "
CRN3850	$\frac{3}{8}$ " x 5"
CRN3855	$\frac{3}{8}$ " x $5\frac{1}{2}$ "
CRN3860	$\frac{3}{8}$ " x 6"
CRN3880	$\frac{3}{8}$ " x 8"
CRN3810	$\frac{3}{8}$ " x 10"
CRN3812	$\frac{3}{8}$ " x 12"

CHROME PIPES

P/N	DESCRIPTION
CRN3816	$\frac{3}{8}$ " x 16"
CRN3818	$\frac{3}{8}$ " x 18"
CRN3824	$\frac{3}{8}$ " x 24"
CRN38300	$\frac{3}{8}$ " x 30"
CRN3836	$\frac{3}{8}$ " x 36"

$\frac{1}{2}$ " **BLACK PIPE** and **NIPPLES** are threaded on both ends. Box/25 (up to 12"); Box/10 (over 12"). Priced each.

P/N	DESCRIPTION
N5000	$\frac{1}{2}$ " Close Black Pipe Nipples
N5015	$\frac{1}{2}$ " x $1\frac{1}{2}$ " Black Pipe Nipples
N5020	$\frac{1}{2}$ " x 2" Black Pipe Nipples
N5025	$\frac{1}{2}$ " x $2\frac{1}{2}$ " Black Pipe Nipples
N5030	$\frac{1}{2}$ " x 3" Black Pipe Nipples
N5035	$\frac{1}{2}$ " x $3\frac{1}{2}$ " Black Pipe Nipples
N5040	$\frac{1}{2}$ " x 4" Black Pipe Nipples
N5045	$\frac{1}{2}$ " x $4\frac{1}{2}$ " Black Pipe Nipples
N5050	$\frac{1}{2}$ " x 5" Black Pipe Nipples
N5055	$\frac{1}{2}$ " x $5\frac{1}{2}$ " Black Pipe Nipples
N5060	$\frac{1}{2}$ " x 6" Black Pipe Nipples
N5012	$\frac{1}{2}$ " x 12" Black Pipe Nipples

P/N	DESCRIPTION
N5018	$\frac{1}{2}$ " x 18" Black Pipe
N5024	$\frac{1}{2}$ " x 24" Black Pipe
N5036	$\frac{1}{2}$ " x 36" Black Pipe

$\frac{3}{8}$ " and $\frac{1}{2}$ " **BLACK PIPE** is threaded on both ends. Boxes of 10 ship UPS. Priced each.

P/N	DESCRIPTION
N3884	$\frac{3}{8}$ " x 84" Black Pipe
N388410	$\frac{3}{8}$ " x 84" Black Pipe, Box/10
N5084	$\frac{1}{2}$ " x 84" Black Pipe
N508410	$\frac{1}{2}$ " x 84" Black Pipe, Box/10

BLACK PIPE FITTINGS

90° ELBOWS

P/N	DESCRIPTION	PKG QTY
BP1	1/4" 90° Black Elbows	35
BP2	3/8" 90° Black Elbows	45
BP3	1/2" 90° Black Elbows	50
BP4	3/4" 90° Black Elbows	35

45° ELBOWS

P/N	DESCRIPTION	PKG QTY
BP7	3/8" 45° Black Elbows	50
BP8	1/2" 45° Black Elbows	50
BP9	3/4" 45° Black Elbows	40

90° REDUCING and STREET ELBOWS.

P/N	DESCRIPTION	PKG QTY
BP36	1/2" x 3/8" 90° Black Reducing Elbows	50
BP37	1/2" x 3/4" 90° Black Reducing Elbows	40
BP49	3/8" 90° Black Street Elbows	40

TEES

P/N	DESCRIPTION	PKG QTY
BP11	1/4" Black Tees	45
BP12	3/8" Black Tees	25
BP13	1/2" Black Tees	35
BP14	3/4" Black Tees	20
BP45	1/2" x 1/2" x 3/8" Black Bulls	20
BP52	1/2" x 1/2" x 3/4" Black Bulls	30

COUPLINGS

P/N	DESCRIPTION	PKG QTY
BP16	1/4" Black Couplings	40
BP17	3/8" Black Couplings	50
BP18	1/2" Black Couplings	40
BP19	3/4" Black Couplings	50

REDUCING COUPLINGS

P/N	DESCRIPTION	PKG QTY
BP26	3/8" x 1/4" Black Reducing Cplg's	30
BP27	1/4" x 1/8" Black Reducing Cplg's	50
BP28	1/2" x 3/8" Black Reducing Cplg's	40
BP29	3/4" x 1/2" Black Reducing Cplg's	60

UNIONS

P/N	DESCRIPTION	PKG QTY
BP21	1/4" Black Unions	20
BP22	3/8" Black Unions	20
BP23	1/2" Black Unions	40
BP24	3/4" Black Unions	40

BUSHINGS

P/N	DESCRIPTION	PKG QTY
BP38	3/8" x 1/4" Black Bushings	75
BP39	3/4" x 1/2" Black Bushings	40
BP44	1/2" x 3/8" Black Bushings	100
BP46	3/4" x 3/8" Black Bushings	40
BP47	1/2" x 1/4" Black Bushings	100

LOCKNUTS

P/N	DESCRIPTION	PKG QTY
BP41	3/8" Black Locknuts	125
BP42	1/2" Black Locknuts	125
BP43	3/4" Black Locknuts	60

PLUG

P/N	DESCRIPTION	PKG QTY
BP48	1/4" Black Plugs	100
BP50	3/8" Black Plugs	100
BP51	1/2" Black Plugs	50



BP3



BP8



BP36



BP49



BP13



← BULL

BP45



BP18



BP28



BP23



BP44



BP42



BP50



PFT2 In Use

The **FireTech™ FITTINGS TOTE TRAY** is ideal for organizing and carrying a wide variety of fittings. Manufactured from 18 ga epoxy-coated steel for superior durability and strength, it comes with seven compartments and features a fold-away handle for easy storage. Measures 15"L x 5"H x 10"W. Red.

P/N	DESCRIPTION
PFT2	Fittings Tote Tray

CHROME PIPE FITTINGS

90° CHROME ELBOWS

P/N	DESCRIPTION	PKG QTY
CR1	1/4" 90° Chrome Elbows	35
CR2	3/8" 90° Chrome Elbows	45
CR3	1/2" 90° Chrome Elbows	50
CR4	3/4" 90° Chrome Elbows	35

45° CHROME ELBOWS

P/N	DESCRIPTION	PKG QTY
CR7	3/8" 45° Chrome Elbows	50
CR8	1/2" 45° Chrome Elbows	50

90° CHROME REDUCING and STREET ELBOWS.

P/N	DESCRIPTION	PKG QTY
CR36	1/2" x 3/8" 90° Chrome Reducing Elbows	50
CR49	3/8" 90° Chrome Street Elbows	40

CHROME TEES

P/N	DESCRIPTION	PKG QTY
CR12	3/8" Chrome Tees	25
CR13	1/2" Chrome Tees	35
CR45	1/2" x 1/2" x 3/8" Chrome Bulls	20

CHROME COUPLINGS and BUSHINGS.

P/N	DESCRIPTION	PKG QTY
CR17	3/8" Chrome Couplings	50
CR18	1/2" Chrome Couplings	40
CR28	1/2" x 3/8" Chrome Reducing Couplings	40
CR44	1/2" x 3/8" Chrome Bushings	100

CHROME UNIONS

P/N	DESCRIPTION	PKG QTY
CR22	3/8" Chrome Unions	20
CR23	1/2" Chrome Unions	40
CR24	3/4" Chrome Unions	40

CHROME PLUGS

P/N	DESCRIPTION	PKG QTY
CR50	3/8" Chrome Plugs	100



CR2



CR7



CR36



CR49



CR12



CR45



CR17



CR28



CR44



CR22

GAS VALVES

Pull-Tite ASCO™ MECHANICAL GAS VALVES are UL classified for use in **Range Guard®**, **Pro-Chem®**, And **Kidde** fire systems (Per NFPA 17 And 17A) and listed with the **Amerex®** system.
NOTE: Valve disassembly voids the manufacturer warranty.

P/N	DESCRIPTION
GVA75	3/4" Mechanical Gas Valve
GVA100	1" Mechanical Gas Valve
GVA125	1 1/4" Mechanical Gas Valve
GVA150	1 1/2" Mechanical Gas Valve
GVA200	2" Mechanical Gas Valve
GVA250	2 1/2" Mechanical Gas Valve
GVA300	3" Mechanical Gas Valve

Trip-to-Close ASCO™ MECHANICAL GAS VALVES are UL classified for use in **Ansul®** systems as well as listed with the **Amerex®** system, per NFPA 17 and 17A.
NOTE: Valve disassembly voids the manufacturer's warranty.

P/N	DESCRIPTION
GVB75	3/4" Mechanical Gas Valve
GVB100	1" Mechanical Gas Valve
GVB125	1 1/4" Mechanical Gas Valve
GVB150	1 1/2" Mechanical Gas Valve
GVB200	2" Mechanical Gas Valve
GVB250	2 1/2" Mechanical Gas Valve
GVB300	3" Mechanical Gas Valve
GVBGP	Cover Plate For GVB-Style Gas Valve

For actuation of a mechanical gas valve (**GVB**), this **PNEUMATIC PISTON** is UL classified for use in **Ansul®** systems, per NFPA 17 and 17A and the manufacturer's installation instructions.

P/N	DESCRIPTION
PKA	Pneumatic Piston Kit Compare to Ansul
PKAKIT	Replacement Hardware (Only)

ASCO™ ELECTRICAL GAS VALVES are for use in all systems and come normally closed without power.
NOTE: All valves must be mounted with the solenoid vertical and upright. Valve disassembly voids the manufacturer's warranty.

P/N	DESCRIPTION
GVC75	3/4" Electric Gas Valve, 110 VAC
GVC100	1" Electric Gas Valve, 110 VAC
GVC125	1 1/4" Electric Gas Valve, 110 VAC
GVC150	1 1/2" Electric Gas Valve, 110 VAC
GVC200	2" Electric Gas Valve, 110 VAC
GVC250	2 1/2" Electric Gas Valve, 110 VAC
GVC300	3" Electric Gas Valve, 110 VAC
GVG24100	1" Electric Gas Valve, 24 VDC
GVG24125	1 1/4" Electric Gas Valve, 24 VDC
GVG24150	1 1/2" Electric Gas Valve, 24 VDC
GVG24200	2" Electric Gas Valve, 24 VDC
COIL7	Replacement Coil For GVC75 Gas Valves
COIL8	Replacement Coil For GVC100-200 Gas Valves
COIL11	Replacement Coil For GVC250-300 Gas Valves
RCAP	Red Plastic Cap

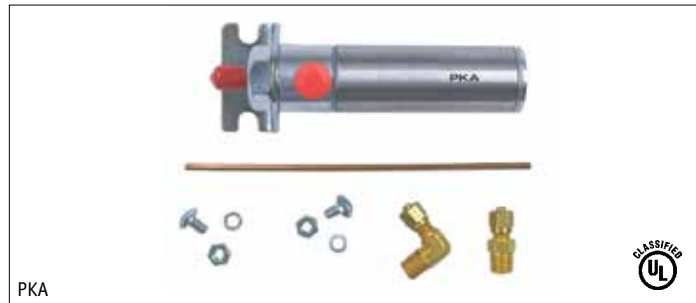



GVBOX



GVNUT

GAS VALVE ACCESSORIES

This **GAS VALVE BOX** is for use with a **GVA** gas valve. (Use **Channellock® Locknut Pliers** for quick and easy adjustments of **GVNUT**).

P/N	DESCRIPTION
GVBOX	Box & Cover For GVA Valve
GVNUT	Special Nut For Fastening GVBOX to GVA Valve



GVK

The **UNIVERSAL GAS VALVE KIT** fits all **GVA** gas valves and comes with the hardware to install the gas valve for release-to-close or trip-to-close operation. (Use **Channellock® Locknut Pliers** for quick and easy adjustments of **GVNUT**).

P/N	DESCRIPTION
GVK	Universal Gas Valve Kit



TL960



TL960 In Use

Channellock® LOCKNUT PLIERS are designed for quick, easy adjustment of electrical locknuts and **GVNUT**. Their thin profile is ideal for use in tight wire-confined electrical boxes. They have spring-loaded locking handles and fit 1/2", 3/4", 1", 1 1/4", and 1 1/2" locknuts.

P/N	DESCRIPTION
TL960	Locknut Pliers



TL960 In Use



KCB

This **CABLE BLOCK** is for use with a **GVA** valve on a **Kidde** system.

P/N	DESCRIPTION
KCB	Cable Block

RESET RELAYS AND CONTRACTORS

Required when using electrical gas valves, these **RESET RELAYS** are UL listed and come complete with wiring and installation instructions. They have wiring diagrams attached to their inside covers and their contacts are rated at 10 A.

NOTE: Must be installed in accordance with system manufacturer's instructions (not included).

P/N	DESCRIPTION
SRR	Reset Relay, 110/120 VAC
SRR24	Reset Relay, 24 VDC



SRR

ELECTRICAL CONTACTORS are 3-pole-resistive, UL recognized components.

P/N	DESCRIPTION
40A110	Electrical Contactor, 40 A, 110 VAC
40A220	Electrical Contactor, 40 A, 220 VAC
50A110	Electrical Contactor, 50 A, 110 VAC
50A220	Electrical Contactor, 50 A, 220 VAC
75A110	Electrical Contactor, 75 A, 110 VAC



50A110

These **STEEL ENCLOSURES** (with baked-on finishes) are pre-drilled with mounting holes to fit our **Electrical Contactors**.

P/N	DESCRIPTION
4050CE*	Steel Enclosure For 40/50 A, 3-Pole Contactors
4075CE	Steel Enclosure For 40 to 75 A, 3-Pole Contactors

*WHILE QUANTITIES LAST!



4050CE



4075CE

The **P2RHK120 HORN STROBE** is UL listed for outdoor use and can operate in extreme temperatures (-40°F to 151°F) and wet or dry conditions. Includes back box.

P/N	DESCRIPTION
P2RHK120	Horn Strobe w/ Box, 120 VAC



P2RHK120



AB6

These 6" **ALARM BELLS** are available in either 120 VAC or 24 VDC operation.

NOTE: NFPA requires an audible or visual indicator to show that the system has operated, that personnel response is needed, and that the system is in need of recharge.

P/N	DESCRIPTION
AB6	Alarm Bell, 120 VAC
AB624	Alarm Bell, 24 VDC
ABBB	Weatherproof Backbox For Alarm Bells





HCSM



HCSD

Offered with either a 1/2" Milwaukee® Holeshooter variable speed corded drill or a 1/2" DeWalt® 3-speed 18V cordless drill (with two batteries and a charger), these **HOLECUTTING SYSTEM II KITS** are designed to simplify and expedite the job of drilling holes in stainless steel, carbon steel, and other hardened metals. Their patented cutter design and coaxial speed reducer offer a 4:1 gear reduction (for the cutter) without reducing the pilot drill speed, making them ideal for cutting holes in stainless steel. Their pilot drills feature a 135° split-point design to ease starting and centering holes. (An existing hole can be enlarged by simply nesting the current hole size cutter inside the new size cutter.)

SYSTEMS INCLUDES:

(1) Arbor, (1) 4" Arbor Extension, (1) 1/2" Stem Adapter, (1) Cutting Lubricant Stick, (1) Speed Reducer, (2) Pilot Drills, Loosening Washers, (1) Hex-Key Wrench, (2) Open-End Wrenches, (1) Clamp & Handle, (1) Original Drill Motor Chuck, Cases, (5) Cutters—3/4", 7/8", 1 1/8", 1 3/8", & 1 5/8".

P/N	DESCRIPTION
HCSM	Hole Cutting System II w/ Milwaukee Drill, Corded
HCSD	Hole Cutting System II w/ Dewalt Drill, Cordless



HC614



HC600

These patented **HOLE CUTTERS** were designed to withstand the hardness of stainless steel, making drilling holes easier than using a standard hole saw. Their triple-tooth design increases cutting pressure for quicker cut holes and increased cutter life. The **ARBOR** is used when placing the cutters into an ordinary drill chuck (without a speed reducer).

P/N	DESCRIPTION
HC614	7/8" Hole Cutter
HC618	1 1/8" Hole Cutter
HC622	1 3/8" Hole Cutter
HC626	1 5/8" Hole Cutter
HC600	Arbor
HC437	Arbor Extension
HC490	Replacement Collar
HC455	Replacement Set Screw
HC705	Cutting Lubricant Stick



HC437



HC490



HC455

Blu-Mol® Xtreme HOLE CUTTERS feature **Tri-Cut Tungsten Carbide Tips** with three distinct cutting edges that balance their cutting performance for longer blade life and better heat resistance. They come with safety collar stops to prevent over-cutting and side holes that remove chips for increased operating speed. They offer 1" depth of cut with self-ejecting plug removal and cut steel, aluminum, and iron. 3/8" (10 mm) chuck shanks are standard.

P/N	DESCRIPTION
E0102338	3/4" Xtreme Hole Cutter
E0102340	7/8" Xtreme Hole Cutter
E0102342	1" Xtreme Hole Cutter
E0102350	1 1/2" Xtreme Hole Cutter



HC705



E0102338

These **PILOT DRILL BITS** are optimized for cutting stainless steel. Their 135° split-point design improves the ease of starting the hole and finish drilling. You get “two bits in one”, just turn them around and their other end is a brand new bit.

P/N	DESCRIPTION
1399DB	1/8" Pilot Drill Bit
HC435	3/16" Pilot Drill Bit

Quick Mount FASTENERS and **INSTALLATION TOOLS** are for hood penetration. Per NFPA 96, any penetrations in the hood exterior are to be sealed with a listed device or by a liquid-tight, continuous external weld. The **QMT (Quick Mount Fastener)** is UL listed for mounting hardware in the hood or duct and meet code without welding. To install: drill hole with **QDRILL**, insert **QMT**, and clinch it with **QMT00L** or **QMT00LM**. **QMS** screws are ideal for mounting fusible link brackets, using the installed **QMT**.

P/N	DESCRIPTION
QMT	Quick Mount Fasteners, Pkg/10
QMS	1/4"-20 Screws, Pkg/100 For QMT
QMT00L	Lever-Type Installation Tool
QMTA	Replacement Arbor For QMT00L
QMT00LM	Wrench-Type Installation Tool
QDRILL	Quick Mount Cobalt Drill Bit, Size “Q”

CARBIDE TIPPED HOLE SAWS feature heat-resistant teeth for maximum performance and service life. They are excellent at cutting stainless steel when using a lubricant at slow speeds.

P/N	DESCRIPTION
HS214	7/8" Carbide Tipped Hole Saw
HS218	1 1/8" Carbide Tipped Hole Saw
HS222	1 3/8" Carbide Tipped Hole Saw
HSA5	Arbor For 7/8", 1 1/8" Saw
HSA6	Arbor For 1 3/8" Saw
HSD297	1/4" Carbide Tipped Pilot Drill Bit
HSD851	1/4" Pilot Drill Bit

The **Vari-Bit® STEP DRILL BIT** cuts faster and lasts longer than hole saws. It needs no pilot holes and cuts up to a 1 3/8" Dia hole. **NOTE:** Use lubricant and slow speeds to maximize life of cutting edges.

P/N	DESCRIPTION
VB12	Step Drill Bit

COBALT DRILL BITS are made of 8% cobalt HSS and designed for heavy-duty drilling through stainless steel.

P/N	DESCRIPTION
40324DB	3/8" Cobalt Drill Bit
41327DB	#27 Cobalt Drill Bit For #10 Sheet Metal Screw
QDRILL	Quick Mount Cobalt Drill Bit, Size “Q”



HC435



QMT00L



QMS, QMT



QMT00LM



HSA5



HS218 w/ HSA5 IN USE



VB12

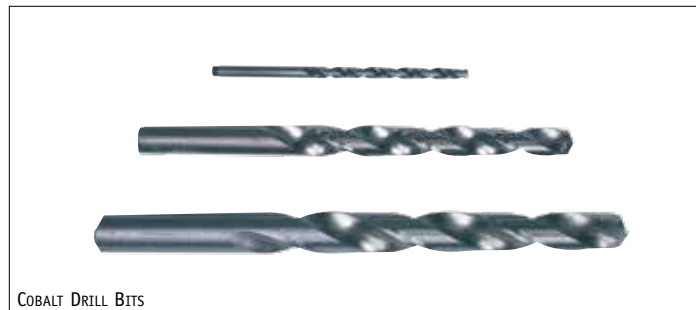

COBALT DRILL BITS

For Additional Tools, See Section 10.

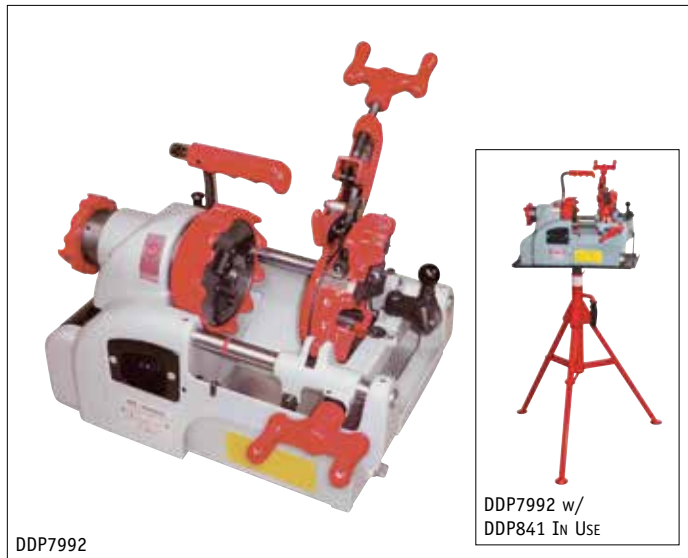

DDP7992

DDP7992 w/
DDP841 In Use

The **Sidekick II** is a full-featured **PIPE THREADING MACHINE** with a manual opening die head for $\frac{1}{4}$ "–1" NPT dies. Its front and rear chucks are great features as are its safety auto shut-off, larger carriage, and unique single-blade reamer. The **Sidekick II** has a noise level of 88 dB, no-load RPM of 55, and a net weight of 63 lb. Three-year warranty (includes the electric motor and $\frac{1}{2}$ "– $\frac{3}{4}$ " and 1" NPT dies). An optional threader stand is available separately.

P/N	DESCRIPTION
DDP7992	Pipe Threading Machine
DDP841	Folding Threader Stand Use w/ DDP7992
DDP60210	$\frac{1}{4}$ "– $\frac{3}{8}$ " NPT Dies For DDP7992
60210	$\frac{1}{4}$ "– $\frac{3}{8}$ " NPT Dies For DDP7992
60211	$\frac{1}{2}$ "– $\frac{3}{4}$ " NPT Dies For DDP7992



TCOG

For optimal cutting performance, keep your pipe threaders filled with premium **THREAD-CUTTING OIL** from **Circle Cut**.

P/N	DESCRIPTION
TCOG	Thread Cutting Oil, 1 gal
TCOG5	Thread Cutting Oil, 5 gal



14CPW

Craftsman® HEAVY-DUTY IRON PIPE WRENCHES

feature tough cast-iron housings and I-beam handles. They come with full-floating hookjaws that use self-cleaning threads.

P/N	DESCRIPTION
10CPW	10" Pipe Wrench $1\frac{1}{2}$ " Capacity
14CPW	14" Pipe Wrench 2" Capacity

These heavy-duty **TUBING CUTTERS** come with hardened steel reamers and spare cutting wheels.



ITC1000

1000TC

P/N	DESCRIPTION
ITC1000	Tubing Cutter
1000TC	Tubing Cutter (Domestic)
TCB	Tubing Cutter Blades, Pkg/2

Easy-to-use, this **FLARING TOOL** efficiently flares tubing ends of seven common sizes ($\frac{3}{16}$ "– $\frac{5}{8}$ ").



TL2880

P/N	DESCRIPTION
TL2880	Flaring Tool

For Additional Tools, See Section 10.

Make changing links fast and easy with these **LINKAGE PLIERS** from **Brooks**. No more scrunching fingers and busting knuckles trying to release cable pressure on scissor brackets. Simply place the specially curved steel jaws in the bracket holes and squeeze for fast, effortless link replacement.

P/N	DESCRIPTION
TL915	Linkage Pliers, Locking
TL910	Linkage Pliers, Non-Locking



TL915 In Use



TL910 In Use

The **HOOD GREASE SCRAPER** comes with a 4" heavy-duty blade and a 6" handle for maximum hood-cleaning efficiency. The **LABEL SCRAPER** comes with a standard razor blade and a trigger for safe, easy blade adjustment.

P/N	DESCRIPTION
SB109	Razor Blades, Pkg/100
LS105	Label Scraper w/ Razor Blade
HS690	Hood Grease Scraper
SB698	Replacement Blades, Pkg/10 For HS690

Our **FOLDING RAZOR SCRAPER** has a quick release so it can be folded, tucking the blade away safely. 8" open, 5" closed.

P/N	DESCRIPTION
HS723	Folding Scraper

The **25" TELESCOPIC MATCH EXTENDER** is for those hard-to-reach pilot lights. It compresses to pen size and comes with a pocket clip.

P/N	DESCRIPTION
ME25	Match Extender

Using a solid aluminum frame, this **TORPEDO LEVEL** features a powerful magnetic edge for hands-free use. Its durable acrylic vials read plumb, level, and 45°.

P/N	DESCRIPTION
TL9919	9" Torpedo Level



HS690



LS105



HS723



ME25 In Use



TL9919

Cools Feet. Protects Appliances.

Our **SYSTEM SERVICE MAT** keeps your feet cool, while protecting appliances, during system maintenance. Made of highly texturized silica-based yarns, it is asbestos-free and heat resistant (up to 2000°F). Measures 20" x 36".

P/N	DESCRIPTION
SSM	System Mat

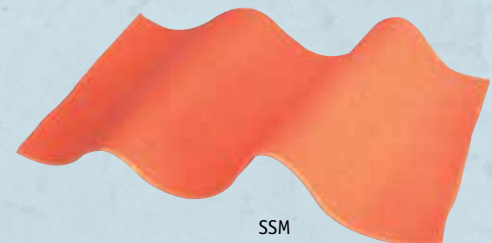

SSM



EZFILL In Use



TL960

FireTech's EZ-FILL SIPHON is not only easy but fast—transferring up to 3.5 gal of liquid per minute. The 6' clear hose is durable, flexible, non-toxic, and has a copper nipple that is anti-static and anti-spark for safety. Use it to transfer liquids, including fuels, oils, water, paint, and more. To operate, make sure the liquid to be transferred is higher than the empty container. Submerge the **EZ-Fill Siphon** and shake it to start the transfer.

P/N	DESCRIPTION
EZFILL	EZ-Fill Siphon



TL960 In Use

Channellock® LOCKNUT PLIERS are designed for quick, easy adjustment of electrical locknuts and **GVNUT**. Their thin profile is ideal for use in tight wire-confined electrical boxes. They have spring-loaded locking handles and fit 1/2", 3/4", 1", 1 1/4", and 1 1/2" locknuts.

P/N	DESCRIPTION
TL960	Locknut Pliers

MANUAL PULL STATION GUARDS

Compatible with **Ansul®** remotes or older **Kidde** remotes, this **SURFACE-MOUNT ROUND REMOTE PULL GUARD** reduces false discharges of fire systems from accidental snagging of manual remote pulls on clothing, food carts, etc. Measures 2 3/4"D x 4 5/8" Dia.

P/N	DESCRIPTION
PG1	Surface-Mount Round Remote Pull Guard

Compatible with **Ansul®** remotes, this **RECESSED ROUND REMOTE PULL GUARD** reduces false discharges of fire systems from accidental snagging of manual remote pulls on clothing, food carts, etc. Measures 1 1/2"D x 4 1/4" Dia.

P/N	DESCRIPTION
PG2	Recessed Round Remote Pull Guard

This **SURFACE-MOUNT REMOTE PULL GUARD** works with **Pyro-Chem®**, **Range Guard®**, **Kidde**, **Amerex®**, or **Buckeye** remotes, reducing false discharges of fire systems from accidental snagging of manual remote pulls on clothing, food carts, etc. Measures 5 3/16"H x 4 3/16"W x 3"D.

P/N	DESCRIPTION
PG3	Surface-Mount Remote Pull Guard

This **SURFACE-MOUNT ROUND REMOTE PULL GUARD** is compatible with **Amerex®** or **Ansul®** remotes and reduces false discharges of fire systems from accidental snagging of manual remote pulls on clothing, food carts, etc. Measures 2 5/8"D x 6" Dia.

P/N	DESCRIPTION
PG4	Surface-Mount Round Remote Pull Guard



PG2 w/ ASRP In Use



PG3 w/ B120110 In Use



PG4 w/ A434618 In Use

IDENTIFICATION SIGNS AND INSPECTION AND INSTALLATION FORMS

SPECIAL USE SIGNS. Per NFPA, a placard identifying the use of the extinguisher as a secondary back-up means to the automatic fire suppression system shall be conspicuously placed near each portable fire extinguisher in the cooking area.

P/N	DESCRIPTION
BL189	Self-Adhesive Vinyl K-Class "Fire Extinguisher" Arrow Sign, 8" x 12"
A273	Aluminum "Fire System to be Activated..." Sign, 3" x 5"

These adhesive-backed aluminum **HOOD IDENTIFICATION SIGNS** come with red lettering and borders for added visibility.

P/N	DESCRIPTION
A272	"Remote Pull Station..." Sign, 3" x 5"
A276	"Fryer" Sign, 2" x 4"
A277	"Griddle" Sign, 2" x 4"
A278	"Broiler" Sign, 2" x 4"
A281	"Hood #1" Sign, 2" x 4"
A282	"Hood #2" Sign, 2" x 4"
A283	"Hood #3" Sign, 2" x 4"
A284	"Hood #4" Sign, 2" x 4"

Custom Signs also Available, See Page 173

Self-adhesive aluminum **HOOD "CAUTION" SIGNS** are designed for suppression system hood use. Red.

P/N	DESCRIPTION
A106	"Caution..." Sign, 2" x 5"
A106S	Spanish "Caution..." Sign, 2" x 5"

Three-part carbonless **PRE-ENGINEERED SYSTEMS INSPECTION FORMS** protect your company by providing a record of service performed. **FLA100** is approved and required by the State of Florida. Pkg/100.

P/N	DESCRIPTION
IF100	Pre-Engineered Systems Inspection Forms
FLA100	Florida Pre-Engineered Systems Inspection Forms

ZIP-LOCK REPORT HOLDER attaches directly to equipment for easy access. Holds 8½" x 11" forms.

P/N	DESCRIPTION
ZLRH	Zip-Lock Holder

CERTIFICATES OF INSPECTION. Measures 8½" x 11". Pkg/100.

P/N	DESCRIPTION
CI100	Certificates of Inspection



BL189



A273



A272



A276



A277



A278



A283



A106



IF100



ZLRH In Use



CI100

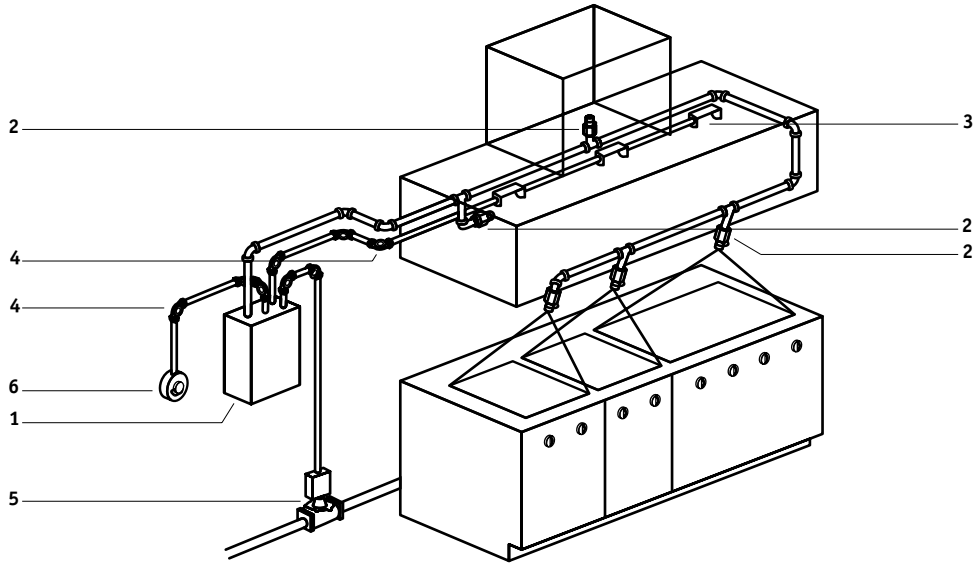

AMEREX® KITCHEN SYSTEM PARTS

ENCLOSURES, TANKS, and BRACKETS (FIG 1).

P/N	DESCRIPTION
AX16921	Model 2.75 Agent Cylinder (Filled & Charged)
AX13334	Model 3.75 Agent Cylinder (Filled & Charged)
AX17379	Model 4.75 Agent Cylinder (Filled & Charged)
AX15196	Model 6.14 Agent Cylinder (Filled & Charged)
AX16920	Bracket w/ Swivel Adapter For 2.75, 3.75, & 4.75 gal Cylinder
AX21583	Bracket w/ Swivel Adapter For 6.14 gal Cylinder
✓ AX18001	MRM II w/ SS Enclosure
✓ AX10147	Pneumatic Actuator
AX10199	Discharge Adapter Kit, 6.14 gal Cylinder
AX10173	Vent Check
AX17484	Low-Pressure Module
AX12854	16" Actuation Hose
AX16448	24" Actuation Hose

✓ **Authorized Distributors Only**



AX13334

CARTRIDGE (FIG 1)

P/N	DESCRIPTION
AX12856	Nitrogen Actuation Cartridge



AX10147



AX10173

CHEMICAL (FIG 1)

P/N	DESCRIPTION
AX16924	Amerex Wet Chemical, 2.75 gal
AX12866	Amerex Wet Chemical, 3.75 gal
AX17450	Amerex Wet Chemical, 4.80 gal
AX15416	Amerex Wet Chemical, 6.14 gal



AX12856



AX12866

MICROSWITCHES (FIG 1)

P/N	DESCRIPTION
AX12524	SPDT Snap Action Microswitch w/ 18" Leads
AX18312	Alarm Microswitch



NOZZLES (FIG 2)

P/N	DESCRIPTION
AX16440	Nozzle Swivel Adapter
AX13729	Fryer & Griddle
AX11982	Appliance & Plenum
AX11983	Solid Fuel Charbroiler
AX11984	Upright Broiler
AX16416	Duct
AX14178	Range & Zone Defense
AX17461	Back Shelf Nozzle



NOZZLE CAPS (FIG 2)

P/N	DESCRIPTION
AX12334	Blow Off Cap, Standard
AX12504	Blow Off Cap, High Temperature



DETECTORS (FIG 3)

P/N	DESCRIPTION
AX12508	Detector Assembly (Bracket, Linkage, & Conduit Fittings)



CORNER PULLEYS (FIG 4)

P/N	DESCRIPTION
AX12309	Amerex Corner Pulley
AX12506	Tee Pulley
AX16444	Corner Pulley (CP5)



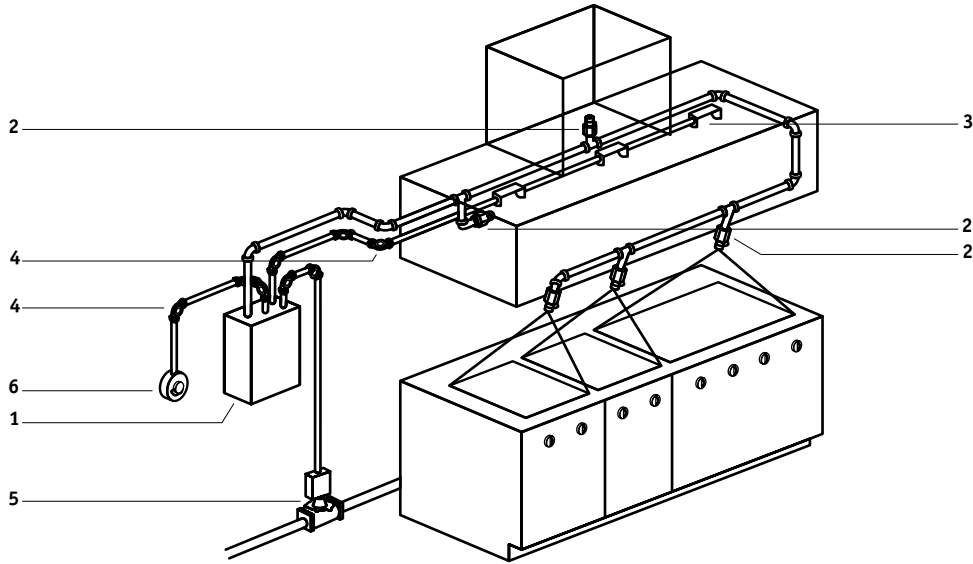

AMEREX® KITCHEN SYSTEM PARTS (CONTINUED)

GAS VALVES and ACCESSORIES (FIG 5).

P/N	DESCRIPTION
AX12790	3/4" Amerex Mechanical Gas Valve
AX12791	1" Amerex Mechanical Gas Valve
AX12792	1 1/4" Amerex Mechanical Gas Valve
AX12793	1 1/2" Amerex Mechanical Gas Valve
AX12794	2" Amerex Mechanical Gas Valve
GVA250	2 1/2" ASCO Mechanical Gas Valve
GVA300	3" ASCO Mechanical Gas Valve
AX13622	Gas Valve Actuator Kit
AX12740	Gas Valve Trip Assembly



AX12791



AX12740

MANUAL PULL STATIONS (FIG 6)

P/N	DESCRIPTION
AX21481	Manual Pull Station (Recess or Surface Mount)



AX21481



AX14899

SERVICE TOOLS and REPAIR PARTS.

P/N	DESCRIPTION
AX14899	Misc Parts Kit
AX20659	Tank Valve Rebuild Kit For 2.75, 3.75, & 4.75 gal Amerex Cylinder
AX12738	Set Up/Lock-Out Tool
AX13341	Cocking Tool
AD36	Recharge Adapter
HTA10	Hydrostat Adapter KP/ZD (275, 375, & 475)
HTA24	Hydrostat Adapter KP/ZD (600)
AX13430	Nitrogen Cylinder Recharge Adapter/ Bracket Kit
AX12855	T-Handle Adapter
EZFILL	EZ-Fill Siphon
AX5239*	Collar O-Ring For 6.14 gal Amerex Cylinder
AX10097	Spring For 6.14 gal Amerex Cylinder
AX10102*	Washer For 6.14 gal Amerex Cylinder
AX10732*	Screw For 6.14 gal Amerex Cylinder
AX15063	Valve Stem For 6.14 gal Amerex Cylinder
AX10733**	Valve Stem O-Ring For 6.14 gal Amerex Cylinder



AX13341



AX13430



AX12855

* MUST BE PURCHASED IN QUANTITIES OF 12

** MUST BE PURCHASED IN QUANTITIES OF 24

SERVICE MANUAL

P/N	DESCRIPTION
AX20150	Service Manual

BRASS FLARE FITTINGS (for system installations) meet SAE J513, as specified in the manufacturer’s manual. Tees and connectors do not include flare nuts.

P/N	DESCRIPTION
FC25	1/4", 45° Flare x 1/4" NPT Male Connector
FN25	1/4", 45° Flare Nut
FT25	1/4", 45° Flare Tee
FC13	1/4", 45° Flare x 1/8" NPT Male Connector



COPPER TUBING for Amerex® system installations.

P/N	DESCRIPTION
ACT049	1/4" x 50' Copper Tubing (0.049" Wall)



Make changing links fast and easy with these **LINKAGE PLIERS** from Brooks. No more scrunching fingers and busting knuckles trying to release cable pressure on scissor brackets. Simply place the specially curved steel jaws in the bracket holes and squeeze for fast, effortless link replacement.

P/N	DESCRIPTION
TL915	Linkage Pliers, Locking
TL910	Linkage Pliers, Non-Locking

Easy-to-use, this **FLARING TOOL** efficiently flares tubing ends of seven common sizes (3/16"–5/8").

P/N	DESCRIPTION
TL2880	Flaring Tool



These heavy-duty **TUBING CUTTERS** come with hardened steel reamers and spare cutting wheels.

P/N	DESCRIPTION
ITC1000	Tubing Cutter
1000TC	Tubing Cutter (Domestic)
TCB	Tubing Cutter Blades, Pkg/2



In Use photos may show items not included or available separately.

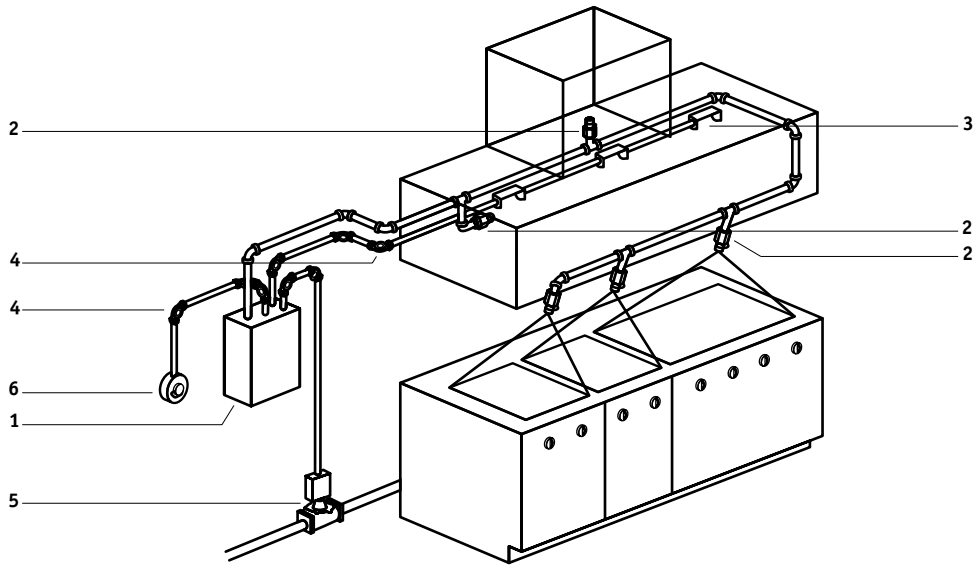

ANSUL® KITCHEN SYSTEM PARTS

Automan® REGULATED RELEASE and **TANKS** (FIG 1).

P/N	DESCRIPTION
✓ A429853	Mechanical Automan Regulated Release**
✓ A429856	Electrical Automan Regulated Release**
✓ A429859	24 VDC Automan Regulated Release**
✓ A429850	Regulated Actuator & Enclosure
✓ A79493	OEM Mechanical Regulated Release
✓ A418054	OEM Electrical Regulated Release
✓ A418691	OEM Regulated Actuator w/ Bracket
✓ A418522	OEM Regulated Actuator w/o Bracket
A429870	Stainless Steel Enclosure (Only)
A429872	Two Tank Stainless Steel Enclosure (Only)
A429864	1.5 gal Stainless Steel Tank
A429862	3 gal Stainless Steel Tank
A429878	3 gal Stainless Steel Tank Bracket
A423744	Replacement Automan Cover
A417582	8" Actuation Hose, Stainless Steel
A31809	16" Actuation Hose, Stainless Steel
A32336	24" Actuation Hose, Stainless Steel
A430815	42" Actuation Hose, Stainless Steel

**ORDER TANKS AND CARTRIDGES SEPARATELY.

✓ **Authorized Distributors Only**



A429853



A429862



A7032, A5373

CARTRIDGES and CAP (FIG 1).

P/N	DESCRIPTION
A7032	LT-20-R Nitrogen Cartridge
A5373	LT-30-R Nitrogen Cartridge
A73022	R-102 Double Cartridge
A17492	101-20 Cartridge
A15851	101-30 Cartridge
A29187	LT-A-101-30 Multiple Cartridge
A77251	RH Threaded Cartridge Shipping Cap

CHEMICAL (FIG 1)

P/N	DESCRIPTION
A79372	Ansulex Liquid Chemical, 3 gal
A79694	Ansulex Liquid Chemical, 1.5 gal
A426199	Ansulex Liquid Chemical, 55 gal Drum
A423320	PRX Liquid Agent, 5 gal
A430182	PRX Liquid Agent, 6 L
A79656	Flushing Concentrate, 32 oz



A79372



A79656

MICROSWITCHES (FIG 1)

P/N	DESCRIPTION
A423878	SPDT Microswitch
A423879	DPDT Microswitch
A423880	3PDT Microswitch
A423881	4PDT Microswitch
A428311	Alarm Release Microswitch
AES	Extension Studs, Pkg/6

NOZZLES for **Ansul® R-102®** and **Piranha®** fire suppression systems (FIG 2) come with replaceable rubber caps.

NOTE: When no longer available, use the streamlined body nozzles below.

P/N	DESCRIPTION
A418569	Nozzle Swivel Adapter
A419337	2W Nozzle (419348)
A419343	2120 Nozzle (419354)

Streamlined **NOZZLES** with metal blow-off caps are direct replacements for the older rubber blow-off cap nozzles above.

P/N	DESCRIPTION
A418569	Nozzle Swivel Adapter
A439825	1F Nozzle (439836/443319)
A439826	1/2N Nozzle (439837/443321)
A439827	1N Nozzle (439838/443317)
A439828	1W Nozzle (439839/443323)
A439829	2W Nozzle (439840/443325)
A439830	3N Nozzle (439841/443327)
A439831	230 Nozzle (439842/443329)
A439832	245 Nozzle (439843/443331)
A439833	260 Nozzle (439844/443333)
A439834	290 Nozzle (439845/443335)
A439835	2120 Nozzle (439846/443337)
A440005	Piranha AP Nozzle (440006/443339)
A440008	Piranha DL Nozzle (440009/443341)
A434455	Henny Penny Nozzle Kit

OLD STYLE NOZZLE CAPS (FIG 2)

BLOW-OFF CAPS help protect system nozzles from accumulation of dirt and grime. Rubber blow-off caps are to be replaced annually.

NOTE: Not for use on the new streamlined nozzles.

P/N	DESCRIPTION
A77695	Rubber Blow-Off Caps, Pkg/50
A433208	CB Metal Blow-Off Caps, Pkg/10
PC551530	Metal Cap O-Rings, Pkg/10

STREAMLINED NOZZLE CAPS (FIG 2)

BLOW-OFF CAPS help protect system nozzles from accumulation of dirt and grime.

P/N	DESCRIPTION
A439861	Streamlined Metal Blow-Off Caps, Pkg/10
A433208	R-102 Nozzle O-Rings, Pkg/25

DETECTORS and PARTS (FIG 3).

P/N	DESCRIPTION
A435546	Terminal Scissor-Style Detector Kit
A435547	Series Scissor-Style Detector Kit
A435545	Replacement Linkage Scissors, Stainless Steel

CORNER PULLEYS (FIG 4)

P/N	DESCRIPTION
A423250	Ansul Corner Pulley
A415670	Ansul Set Screw Corner Pulley
A427929	Ansul Tee Pulley

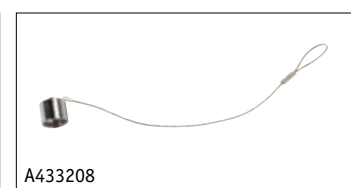
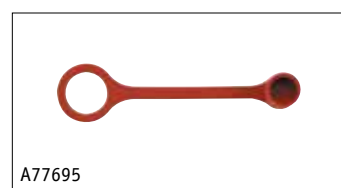
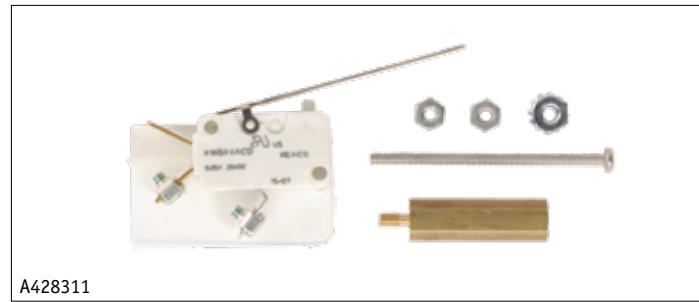

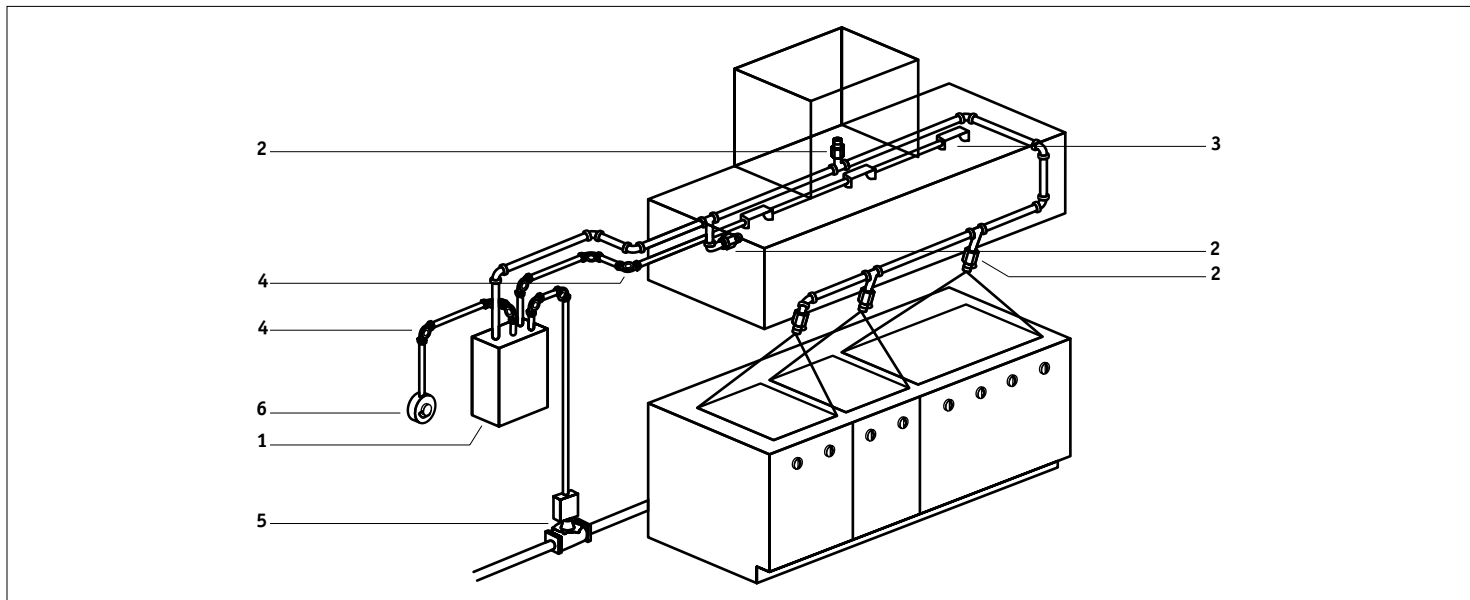

ANSUL® KITCHEN SYSTEM PARTS (CONTINUED)

GAS VALVES and ACCESSORIES (FIG 5).



P/N	DESCRIPTION
A55598	3/4" Ansul Mechanical Gas Valve
A55601	1" Ansul Mechanical Gas Valve
A55604	1 1/4" Ansul Mechanical Gas Valve
A55607	1 1/2" Ansul Mechanical Gas Valve
A55610	2" Ansul Mechanical Gas Valve
GVB250	2 1/2" ASCO Mechanical Gas Valve**
GVB300	3" ASCO Mechanical Gas Valve**
A15733	Pneumatic Piston Kit
A416018	Cocking Lever – Mechanical Gas Valve

**ORDER P/N A15733 SEPARATELY FOR THE ASCO VALVES. ANSUL® VALVES INCLUDE THE PNEUMATIC PISTON KIT.



REMOTE PULL STATIONS and ACCESSORIES (FIG 6).



P/N	DESCRIPTION
A434618	Remote Pull Station w/o Cable
A435960	Remote Pull Station w/ 50' Cable
A435725	Bearings & Bolts, Pkg/10
A435726	For Remote Pull Pull Tabs, Pkg/10
RPBOX	Non-Chrome Remote Pull Box
ARBOX	Chrome Remote Pull Box

FLEXIBLE CONDUIT and ACCESSORIES.



P/N	DESCRIPTION
A434525	Flexible Conduit, 500'
A435959	Flexible Conduit w/ Wire Rope, 500'
A435979	Flexible Conduit Strain Relief, Pkg/50
A434347	Flexible Conduit Inserts, Pkg/50
A436150	P-Clip, Pkg/50
A436063	Conduit Offset, Pkg/6

ACCESSORIES

P/N	DESCRIPTION
A79318	R-102 Regulator
A417911	R-102 Bursting Discs, Pkg/10
56909AS	Collar O-Ring – System Tank
A68800	Vent Plug
A79007	R-102 Hose Assembly
A418511	Hose/Grommet Package
A417700	Siphon Tube Assembly
A416970	Bursting Disc Union Assembly
N1800	1/8" Close Nipple For Actuating Line
BP27	1/4" x 1/8" Reducing Cplg For Actuating Line
435982AS	Agent Dist Kit, 5'

SERVICE TOOLS

P/N	DESCRIPTION
A441041	Cocking Lever & Bar
A441042	Short Locking Lever & Bar
A14985	Locking Bar (Only)
A416018	Cocking Lever – Mechanical Gas Valve
TL915	System Linkage Pliers, Locking
TL910	System Linkage Pliers, Non-Locking
EZFILL	EZ-Fill Siphon
HTA42	Hydro Adapter – R-102 w/ Internal Threads
A438031	Locking Pin

SERVICE MANUALS

P/N	DESCRIPTION
A2006144	R-102 UL300 Wet Chemical Fire Suppression System Manual

ANSUL® INDUSTRIAL SYSTEM PARTS

ACCESSORIES

P/N	DESCRIPTION
A13193	LT-10-R Cartridge, 10 lb
A15850	101-10 Cartridge, 10 lb
A416698	Valve Stem & O-Ring Assembly (IND-X)
A415843	Replacement O-Ring (IND-X) For Stem
A417809	Recharge Adapter (IND-X)
A416018	Cocking Lever – Mechanical Gas Valve
A26310	Cocking Lever – Ansul Automan II-C
A9336	Ansul® Plus-Fifty C™ Dry Chemical, 50 lb Pail

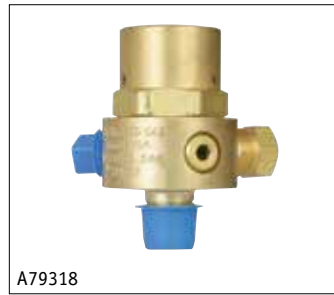

A79318



A417700



A416970



A416018 In Use



A441041



TL915



TL910

ANSUL® INDUSTRIAL SYSTEM PARTS

ACCESSORIES

P/N	DESCRIPTION
A13193	LT-10-R Cartridge, 10 lb
A15850	101-10 Cartridge, 10 lb
A416698	Valve Stem & O-Ring Assembly (IND-X)
A415843	Replacement O-Ring (IND-X) For Stem
A417809	Recharge Adapter (IND-X)
A416018	Cocking Lever – Mechanical Gas Valve
A26310	Cocking Lever – Ansul Automan II-C
A9336	Ansul® Plus-Fifty C™ Dry Chemical, 50 lb Pail



EZFILL In Use



A416698



A9336

In Use photos may show items not included or available separately.

Ansul®, Piranha®, Automan®, and Plus-Fifty® are registered marks of Tyco Fire Products LP.



CP5



Brooks' high-temperature ball bearing **COMPRESSION CORNER PULLEY** is UL classified for use in **Ansul®** fire suppression systems, per NFPA 17 and 17A. Its steel compression nuts eliminate thread stripping, and it has more threads than most for a stronger, easier-to-install corner pulley. Its ball bearing roller is pressed into place and stays when you remove the cover.

P/N	DESCRIPTION
CP5	Compression Corner Pulley

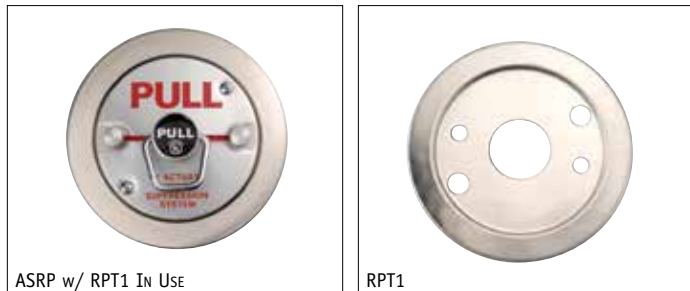

ASRP w/ RPT1 In Use



RPT1

The **REMOTE PULL** is UL classified for use in **Ansul®** fire suppression systems, per NFPA 17 and 17A.

P/N	DESCRIPTION
ASRP	Remote Pull
RPT1	ASRP Stainless Steel Trim
RSS	Set Screws, Pkg/10 For ASRP Break Rod Post

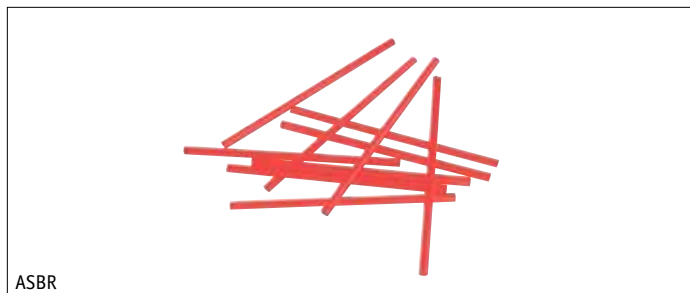

ASBR

These **BREAK RODS** are compatible with the **Ansul®** remote pull and the **ASRP**. Pkg/10.

P/N	DESCRIPTION
ASBR	Remote Break Rods



ARBOX

JUNCTION BOXES for mounting remote pulls.

P/N	DESCRIPTION
RPBOX	Non-Chrome Remote Pull Box
ARBOX	Chrome Remote Pull Box

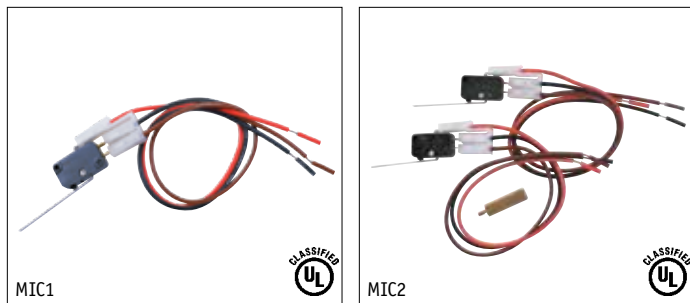

MIC1



MIC2



UL classified **MICROSWITCHES** for **Ansul®** systems come complete with wiring harnesses and hardware.

P/N	DESCRIPTION
MIC1	SPDT Microswitch
MIC2	DPDT Microswitch
AES	Extension Studs, Pkg/6 To Add More Switches

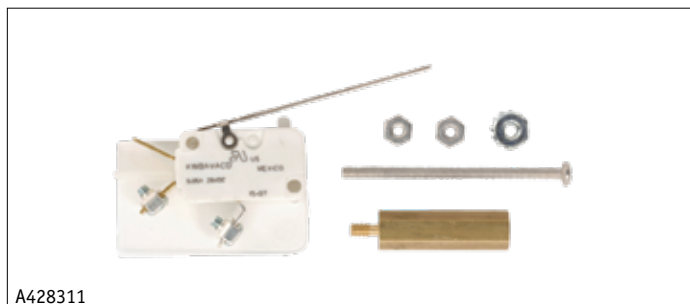

A428311

Alarm initiating **MICROSWITCH KIT** is for connection between **Ansul® Automan** and a fire alarm control panel.

P/N	DESCRIPTION
A428311	Alarm Microswitch

In Use photos may show items not included or available separately.

Automan® is a registered mark of Tyco Fire Products LP.

Take the guesswork out of nozzle positioning with this **NOZZLE AIMING DEVICE**. It mounts directly onto a nozzle and uses a small laser light to reflect on the surface at which it is aimed. Move the nozzle until it is aimed correctly, then tighten it into place.
NOTE: Adapters for nozzle aiming device sold separately.

P/N	DESCRIPTION
PC551265	Nozzle Aiming Device (Only)
A439876	Adapter, White (Ansul)

For Aiming Device
 EL1CR2* Replacement Batteries, Pkg/2

*UNAVAILABLE IN AK, HI, PR, OR CATALINA



PC551265



A439876

Dow Corning® SILICONE GREASE NO. 111 is recommended by **Ansul** for use with rubber and metal blow-off caps on discharge nozzles, protecting both caps and nozzle orifices.
NOTE: Re-application required at each semi-annual maintenance examination.

P/N	DESCRIPTION
SL111	Silicone Grease No. 111



SL111

These aluminum **BURSTING DISCS** are installed to prevent the extinguishing agent from entering the pipe during extreme temperature variations. Pkg/25.

NOTE: BDA is for dry chemical systems only.

P/N	DESCRIPTION
BDA	Aluminum Bursting Discs



BDA



R102BDA

R-102® BURSTING DISCS are installed to prevent extinguishing agents from entering the pipe during extreme temperature variations. Pkg/10.

NOTE: R102BDA is for R-102 wet chemical systems only.

P/N	DESCRIPTION
R102BDA	R-102 Bursting Discs

The **PNEUMATIC PISTON KIT** is for actuating a mechanical gas valve and is UL classified for use in **Ansul®** systems, per NFPA 17 and 17A.

P/N	DESCRIPTION
PKA	Pneumatic Piston Kit
PKAKIT	Replacement Hardware (Only)

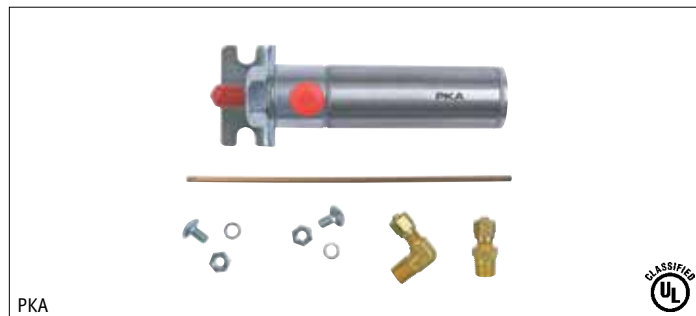

PKA



As required every 12 years, per the **Ansul®** maintenance manual, this **REGULATOR TEST KIT** is for testing the **Ansul Automan®** regulator.

P/N	DESCRIPTION
RTK	R-102 Regulator Test Kit
RTK6	RTK Gauge, 300 psi

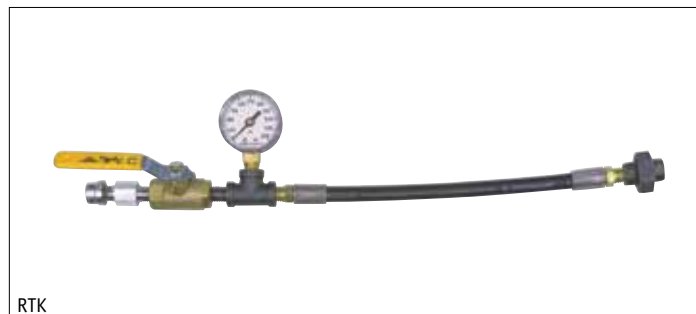

RTK

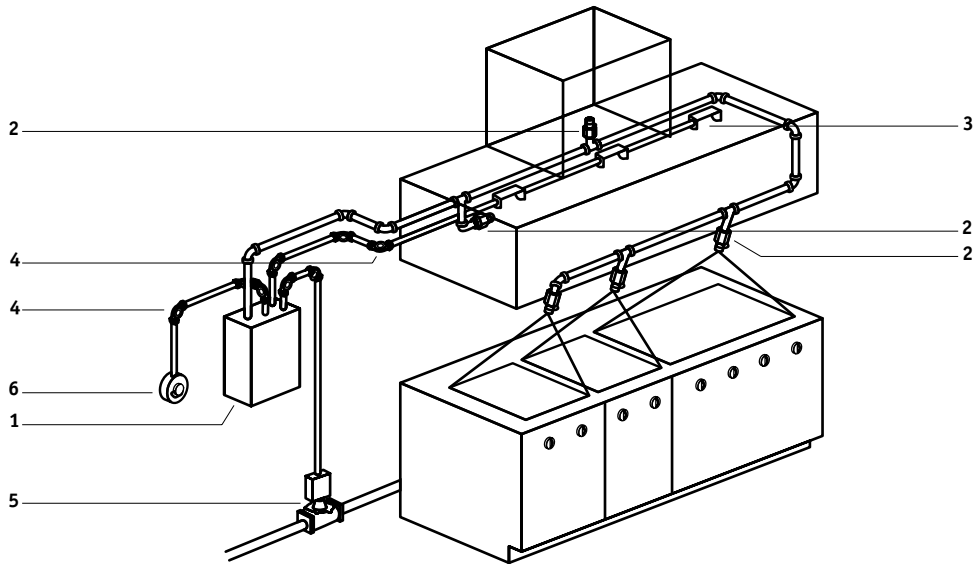

KIDDE AND BADGER™ RANGE GUARD® KITCHEN SYSTEM PARTS

CYLINDERS, CONTROL HEADS, and BRACKETS (FIG 1).

P/N	DESCRIPTION
K120001	WHDR-125 Charged Cylinder, 1.25 gal – Kidde
B120001	RG-1.25G Cylinder/Valve, 1.25 gal – Badger
K120002	WHDR-260 Charged Cylinder, 2.6 gal – Kidde
B120002	RG-2.5G Cylinder/Valve, 2.5 gal – Badger
K120003	WHDR-400S Charged Cylinder, 4 gal – Kidde
B120003	RG-4S Short Cylinder/Valve, 4 gal – Badger
K120006	WHDR-400M Charged Cylinder, 4 gal – Kidde
B120006	RG-4M Medium Cylinder/Valve, 4 gal – Badger
K120005	WHDR-600 Charged Cylinder, 6 gal – Kidde
B120005	RG-6G Cylinder/Valve, 6 gal – Badger
KR844908	Discharge Adapter Kit
✓ K1200992	New XV Control System – Kidde
✓ B1200992	New UCH Control System – Badger
✓ K1200101	KRS-50 Control Box Assembly – Kidde
✓ B1200101	A+ Control Box Assembly – Badger
KR120042	System Valve Actuator
B9189412	Pneumatic Release – Badger
KR045001	High-Pressure Hose, 7½"
KR045002	High-Pressure Hose, 24"
KR045003	High-Pressure Hose, 60"
KR9197430	Wall Bracket, 1.3 gal Cylinder
KR9197263	Wall Bracket, 2.6 gal Cylinder
KR9197415	Wall Bracket, 4 gal Short Cylinder
KR9197414	Wall Bracket, 4 gal Medium Cylinder
KR100013	Shelf Bracket, 4 gal Med & 6 gal Cylinders
KR100010	Floor Mtg. Kit, 4 gal Med & 6 gal Cylinders

Requires KR100013 Bracket
✓ **Authorized Distributors Only**

ACTUATOR CARTRIDGES (FIG 1) KR120043 and

KR235557 must be periodically replaced in accordance with the **Kidde/Range Guard®** manual. Refer to manual for replacement intervals and installation instructions. **KR120044** is a test cartridge used during semi-annual and annual service only.

NOTE: Make sure to check cartridge weight before installation.

P/N	DESCRIPTION
KR120043	Nitrogen Actuator Cartridge XV, UCH Control
KR235557	12 g CO ₂ Actuator Cartridge KRS-50, A+
KR120044	Nitrogen Test Cartridge XV, UCH Control



K120001



B120002



K1200992



B1200101



KR844908



KR120043



KR235557



KR120044

CHEMICAL (FIG 1)

P/N	DESCRIPTION
KR120030	APC Wet Chemical, 1.25 gal
KR120031	APC Wet Chemical, 2.5 gal
KR120032	APC Wet Chemical, 4 gal
KR120033	APC Wet Chemical, 6 gal



KR120031



KR120032

MICROSWITCHES and PRESSURE SWITCH (FIG 1).

P/N	DESCRIPTION
KR120039	SPDT Microswitch <i>XV, UCH Control</i>
KRST120039	SPDT Striped Microswitch <i>XV, UCH Control</i>
KR120047	Alarm Release Microswitch <i>XV, UCH Control</i>
KR97227	SPDT Microswitch <i>KRS-50, A+</i>
KR97228	DPDT Microswitch <i>KRS-50, A+</i>
KR100034	Electric Actuator Kit, 24 VDC Solenoid <i>XV, UCH Control</i>
KR9197023	SPDT Pressure Switch



KR120039



KR120047

NOZZLES (FIG 2)

P/N	DESCRIPTION
KR120021	Swivel Adapter, 3/8"
KR120011	ADP Nozzle
KR120012	F Nozzle
KR120013	GRW Nozzle
KR120014	R Nozzle
KR120015	DM Nozzle
KR120022	LPF Nozzle
KR120024	LPR Nozzle



KR120021



KR120011



KR120014

NOZZLE SEALS and CAPS (FIG 2).

P/N	DESCRIPTION
KR97054	Foil Nozzle Seals/Discs, Pkg/10
KR97290	Chrome Nozzle Caps, Pkg/10
KR120026	Nozzle Cap (LPR Nozzle Only)

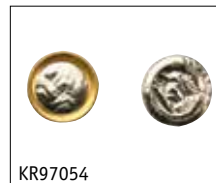

KR97054



KR97290



KR120026

DETECTORS (FIG 3)

P/N	DESCRIPTION
KR804548	Link Detector Kit <i>XV, UCH Control</i>
KR120064	Universal Link Detector Kit



K844648



B844648

CORNER PULLEYS (FIG 4)

P/N	DESCRIPTION
K844648	Kidde Corner Pulley
B844648	Badger Corner Pulley
KR843792	Kidde/Badger Double Tee Pulley

GAS VALVES (FIG 5)

P/N	DESCRIPTION
KR120071	3/4" Mechanical Gas Valve
KR120072	1" Mechanical Gas Valve
KR120073	1 1/4" Mechanical Gas Valve
KR120074	1 1/2" Mechanical Gas Valve
KR120075	2" Mechanical Gas Valve
KR120076	2 1/2" Mechanical Gas Valve
KR120077	3" Mechanical Gas Valve



KR120071

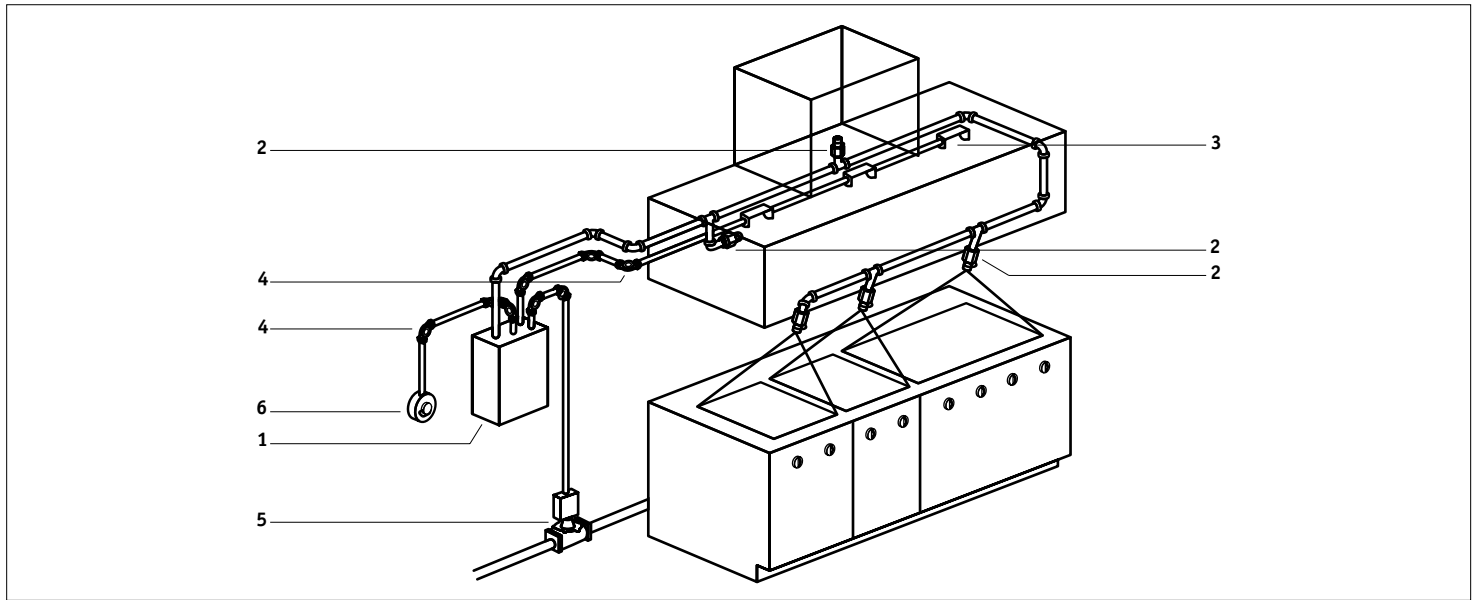

KIDDE AND BADGER™ RANGE GUARD® KITCHEN SYSTEM PARTS (CONTINUED)

REMOTE PULL STATIONS (FIG 6)

P/N	DESCRIPTION
K120110	Remote Manual Release – Kidde
B120110	Remote Manual Release – Badger

ACCESSORIES

P/N	DESCRIPTION
KR120067	Valve Assembly Rebuild Kit
KR120046	Rebuild Kit, XV, UCH Control System Valve
KR131024	Gauge Shield
KR87120072	UCH Valve Body Update Kit
KR237167	Piercing Pins, Yellow, Pkg/10
KR197215	Piercing Pins (KRS-50), Pkg/10
KR490004	Valve Stem Snap Rings, Pkg/10
OR43	O-Ring, Valve Neck (64350327)
OR4	O-Ring, Valve Stem
KR1419239*	O-Ring, Puncture Stem
KR236204	Flat Gasket, XV, UCH Control
KR97220	Cable Tensioning Block, A+
KR120068	Solid Plug
KR96984	Vent Plug
GPC175	Wet Chemical Gauge, 175 psi
GPC225	Wet Chemical Gauge, 225 psi
B120009	Valve Assembly For Range Guard Cylinders
KR117989	Replacement Straps For Cylinder Mounting Brackets

*WHILE QUANTITIES LAST!

SERVICE TOOLS

P/N	DESCRIPTION
KR844908	Discharge Adapter Kit
KR253538	Crimp Tool
KR255096	Valve Top Protection Plate
KR255681	Anti-Recoil Plate
HTA24	Hydrotest Adapter
KR279262	Recharge Adapter
KR9197108	Keeper Pin

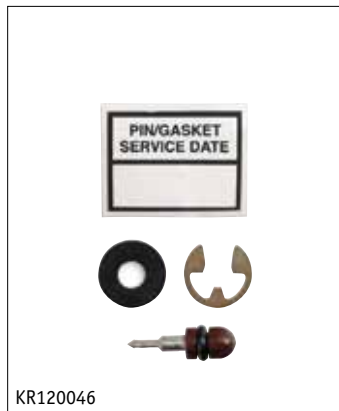

OLDER RANGE GUARD® PARTS

UL classified **Range Guard®-style MICROSWITCHES** (for older control heads) come complete with wiring harnesses and hardware.

P/N	DESCRIPTION
MIC4	Range Guard-Style SPDT Microswitch
MIC5	Range Guard-Style DPDT Microswitch
MIC6	Range Guard & Kidde-Style SPDT "A+", KRS-50, Series Microswitch
MIC7	Range Guard & Kidde-Style DPDT "A+", KRS-50, Series Microswitch

MISCELLANEOUS PARTS

P/N	DESCRIPTION
RG118031	System Gauge, 175 psi
RGVS	Valve Stem For Old RG Cylinder
RG97009	Cocking Tool For Mechanical Control Head
OR45	O-Ring – Ring Nut (00061) For Old RG Cylinder

Brooks' high-temperature ball bearing COMPRESSION CORNER PULLEY is UL classified for use in **Kidde** and **Range Guard®** fire suppression systems, per NFPA 17 and 17A. Its steel compression nuts eliminate thread stripping, and it has more threads than most for a stronger, easier-to-install corner pulley. Its ball bearing roller is pressed into place and stays when you remove the cover.

P/N	DESCRIPTION
CP5	Compression Corner Pulley

CO₂ ACTUATOR CARTRIDGES are UL classified for **Kidde** and **Range Guard** and, along with O-rings, must be periodically replaced in accordance with the **Kidde** or **Range Guard** manual. Refer to manual for replacement intervals and installation instructions. Pkg/3.

TIP: Make sure to weigh cartridge before installation.

P/N	DESCRIPTION
KRC	12 g CO ₂ Actuator Cartridges

BRASS FLARE FITTINGS are for system installations and meet SAE J513, as specified in the manufacturer's manual.

NOTE: Tees and connectors do not include flare nuts.

P/N	DESCRIPTION
FC25	1/4", 45° Flare x 1/4" NPT Male Connector
FN25	1/4", 45° Flare Nut
FT25	1/4", 45° Flare Tee
FC13	1/4", 45° Flare x 1/8" NPT Male Connector

COPPER TUBING for system installations.

P/N	DESCRIPTION
CT50	1/4" x 50' Copper Tubing (1/32" Wall)

KIDDE CO₂ SYSTEM ADAPTER

P/N	DESCRIPTION
KC02	CO ₂ System Adapter

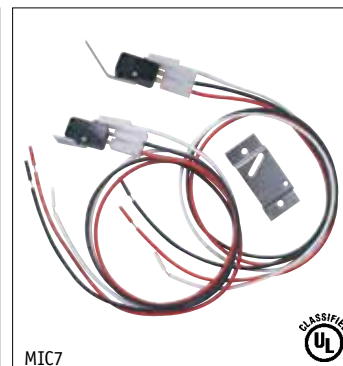

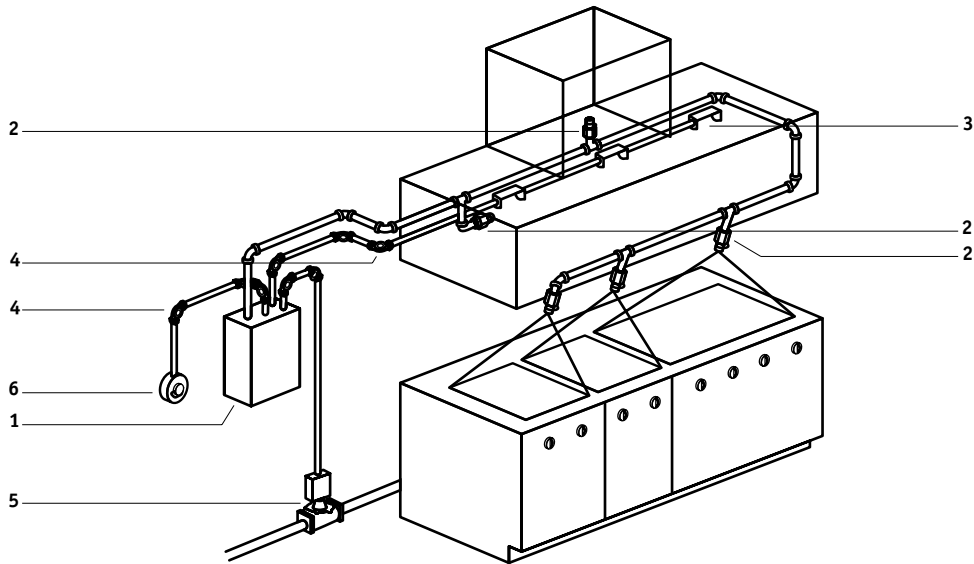

PYRO-CHEM® KITCHEN SYSTEM PARTS

CYLINDERS, ENCLOSURES, and BRACKETS (FIG 1).

P/N	DESCRIPTION
PC553163	PCL 160 Charged Cylinder, 1.6 gal
PC551194	PCL 300 Charged Cylinder, 3 gal
PC551193	PCL 460 Charged Cylinder, 4.6 gal
PC551196	PCL 600 Charged Cylinder, 6 gal
PC550053	MB-1 Cylinder Bracket For PLC 600
PC550054	MB-15 Cylinder Bracket For PLC 160, PCL 300, and PCL 460
PC550103	PAC-10 Cylinder Bracket
PC550966	EN-S Enclosure For Secondary Cylinders
✓ PC551204	NMCH-DPT Control Head w/ Switch
PC550853	MB-P2 Control Head Mounting Bracket
PC550104	PAC-10 Pneumatic Actuating Cylinder
PC550093	PAC-100 Pneumatic Actuating Cylinder
PC417582	8" Actuation Hose, Stainless Steel
PC31809	16" Actuation Hose, Stainless Steel
PC32336	24" Actuation Hose, Stainless Steel
PC430815	42" Actuation Hose, Stainless Steel

✓ **Authorized Distributors Only**



PC551194



PC550853



PC550104



PC551059

ACTUATOR CARTRIDGES (FIG 1) and O-rings must be

periodically replaced in accordance with the **Pyro-Chem®** manual.

Refer to manual for replacement intervals and installation instructions.

TIP: Make sure to check cartridge weight before installation.

P/N	DESCRIPTION
PC551059	16 g CO ₂ Actuator Cartridge
PC55531	O-Ring For Actuator Cartridge



PC79656



PC551188

CHEMICAL (FIG 1)

P/N	DESCRIPTION
PC553176	RL-160, 1.6 gal Recharge Agent
PC551188	RL-300, 3.0 gal Recharge Agent
PC79656	Flushing Concentrate, 32 oz

MICROSWITCHES (FIG 1)

P/N	DESCRIPTION
PC550227	SPDT Microswitch (Old Style)
PC550237	DPDT Microswitch (Old Style)
PC551154	SPDT Microswitch
PC551155	DPDT Microswitch
PC551156	3PDT Microswitch
PC551157	4PDT Microswitch
PC550077	Alarm Microswitch
PC552173	Microswitch Extension Kit

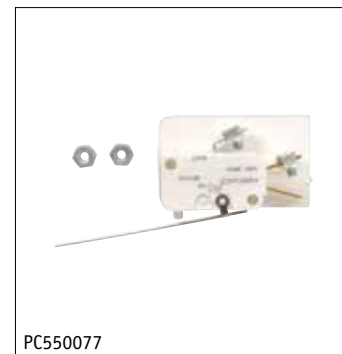

NOZZLES (FIG 2)

P/N	DESCRIPTION
PC418569	Swivel Adapter
PC551026	1L Nozzle
PC551027	2L Nozzle
PC551028	2H Nozzle
PC551029	1H Nozzle
PC551038	2D Nozzle



Replacement **NOZZLE CAPS (FIG 2)**.

NOTE: Pyro-Chem requires that the rubber caps (PC550016) be replaced annually.

P/N	DESCRIPTION
PC623	NL Series Nozzle Cap
PC550016	Rubber Nozzle Caps, Pkg/12
PC551530	Nozzle O-Rings (PC625), Pkg/10



DETECTORS and PARTS (FIG 3).

P/N	DESCRIPTION
PC435547	Series Detector ASM
PC435546	Terminal Detector ASM
PC435545	Scissor Linkage
PCFLH	Fusible Link Hanger



CORNER PULLEYS (FIG 4)

P/N	DESCRIPTION
PC423250	Compression Corner Pulley
PC415670	Set Screw Corner Pulley
PC427929	Tee Pulley



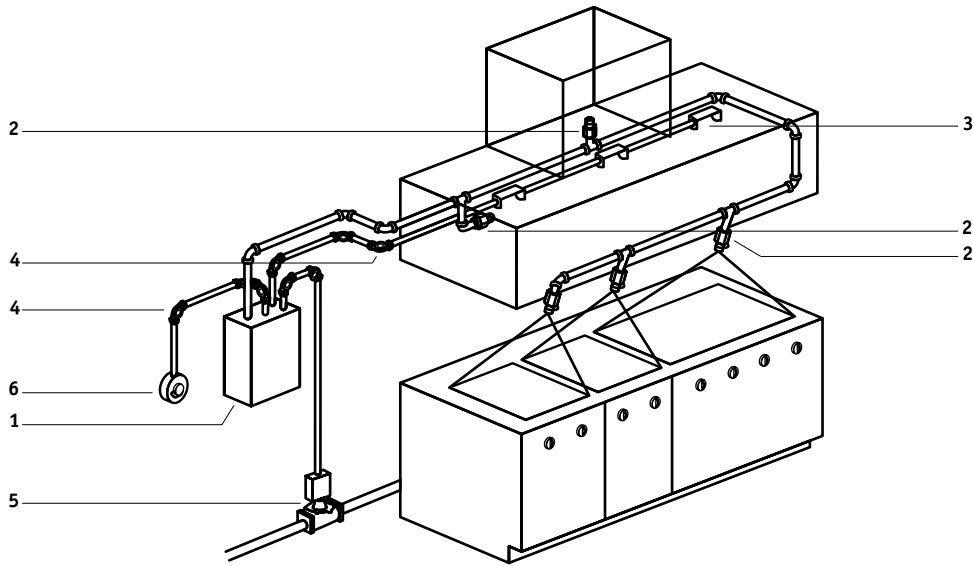

PYRO-CHEM® KITCHEN SYSTEM PARTS (CONTINUED)

GAS VALVES (FIG 5)

P/N	DESCRIPTION
PC550593	3/4" Mechanical Gas Valve
PC550594	1" Mechanical Gas Valve
PC550595	1 1/4" Mechanical Gas Valve
PC550596	1 1/2" Mechanical Gas Valve
PC551049	2" Mechanical Gas Valve
PC550185	2 1/2" Mechanical Gas Valve
PC550186	3" Mechanical Gas Valve



PC550595

REMOTE PULL STATION (FIG 6)

P/N	DESCRIPTION
PC551074	Remote Pull (RPSM)
PC551167	Electrical Remote Pull
ASBR	Remote Break Rods, Pkg/10



PC551074



ASBR

FLEXIBLE CONDUIT and ACCESSORIES.

P/N	DESCRIPTION
A434525	Flexible Conduit, 500'
A435959	Flexible Conduit w/ Wire Rope, 500'
A435979	Flexible Conduit Strain Relief, Pkg/50
A434347	Flexible Conduit Inserts, Pkg/50
A436150	P-Clips, Pkg/50
A436063	Conduit Offsets, Pkg/6



A435979



A434347

ACCESSORIES

P/N	DESCRIPTION
PC550698	Wet Valve Rebuild Kit
PC551061	Regulator Rebuild Kit
GPC225	Wet Chemical Gauge, 225 psi
PC550716	Wet Valve Neck O-Ring (420716)



PC550698



PC551061

SERVICE TOOLS

P/N	DESCRIPTION
PC550788	Wet Valve Tool
PC551240	Recharge Adapter For Kitchen Knight II
HTA41	Hydrotest Adapter
EZFILL	EZ-Fill Siphon
PC550938	Bleed Down Adapter

SERVICE MANUAL

P/N	DESCRIPTION
PC551274	Kitchen Knight II Manual (2009)

Take the guesswork out of nozzle positioning with this **NOZZLE AIMING DEVICE**. It mounts directly onto a nozzle and uses a small laser light to reflect on the surface at which it is aimed. Move the nozzle until it is aimed correctly, then tighten it into place.
NOTE: Adapters for nozzle aiming device sold separately.

P/N	DESCRIPTION
PC551265	Nozzle Aiming Device (Only)
PC550926	Pyro-Chem Adapter, Black For Aiming Device
EL1CR2*	Replacement Batteries, Pkg/2

*UNAVAILABLE IN AK, HI, PR, OR CATALINA

PYRO-CHEM® INDUSTRIAL DRY SYSTEM PARTS

NOZZLES and CAPS.

P/N	DESCRIPTION
PC551650	NV-WA Nozzle
PC551651	NV-UF Nozzle
PC551652	NV-P1 Nozzle
PC551653	NV-DP2 Nozzle
PC551098	N-SCR Nozzle
PC551099	N-OTF Nozzle
PC551100	N-PLU Nozzle
PC551101	N-DCT Nozzle
PC551678	NF-ABC Nozzle
PC550646	N-LA-ABC Nozzle
PC550342	N-LA-BC Nozzle
PC550337	NF-TS Nozzle
PC550333	Nozzle Cap
PC550644	Nozzle Cap

ACCESSORIES

P/N	DESCRIPTION
PC550037	Dry Valve Rebuild Kit
PC550877	VT-2 Dry Valve Tool
PC553565	Pyro-Chem Industrial Manual
PC550026	Safety Release Plug
PC550130	Dry Valve Recharge Adapter
10064	1/2" Hex Wrench



EZFILL In Use



PC550788

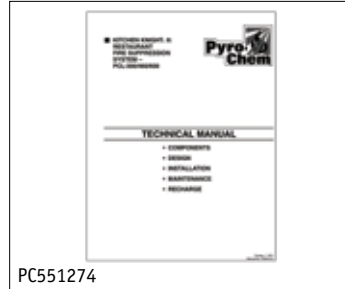

PC551274



PC551265



PC551265 w/ PC550926 In Use



PC551265 w/ PC550926 In Use



PC551650



PC551653



PC551099



PC551100



PC550337



PC550644



PC550037



PC550877

In Use photos may show items not included or available separately.

Pyro-Chem® is a registered mark of Tyco Fire Products LP.



CP5



Brooks' high-temperature ball bearing **COMPRESSION CORNER PULLEY** is UL classified for use in **Pyro-Chem®** fire suppression systems, per NFPA 17 and 17A. Its steel compression nuts eliminate thread stripping, and it has more threads than most for a stronger, easier-to-install corner pulley. Its ball bearing roller is pressed into place and stays when you remove the cover.

P/N	DESCRIPTION
CP5	Compression Corner Pulley



LBK1



This **10" FUSIBLE LINK BRACKET** is UL classified for use in **Pyro-Chem®** systems, per NFPA 17 and 17A.

P/N	DESCRIPTION
LBK1	10" Link Bracket



LBK3



Offering better air flow around fusible links, this **10" HIGH STAND OFF FUSIBLE LINK BRACKET** is UL classified for use in **Pyro-Chem®** systems, per NFPA 17 and 17A. (It matches up to a **CP5** when coming through the top of a hood with a **GSA12**.)

P/N	DESCRIPTION
LBK3	10" High Stand Off Link Bracket

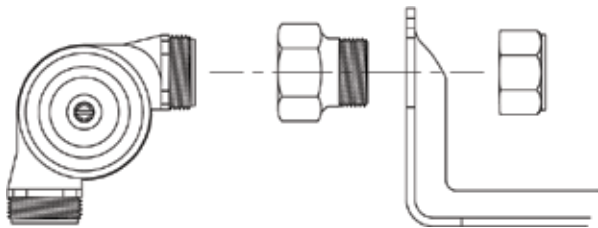

LHAK In Use

Facilitating the attachment of a **Pyro-Chem®** large-threaded corner pulley to an **LBK3** fusible link bracket, this **LINK HOUSING ADAPTER KIT** reduces the larger threads of the corner pulley to fit the smaller-diameter link bracket hole. No conduit or conduit fittings are required either. Kit comes with one reducing adapter and one steel nut.

P/N	DESCRIPTION
LHAK	Link Housing Adapter Kit

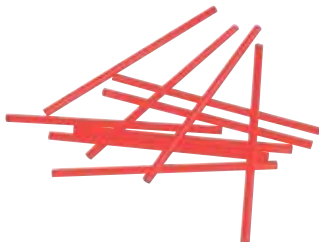

ASBR

These **BREAK RODS** are compatible with remote pulls. Pkg/10.

P/N	DESCRIPTION
ASBR	Remote Break Rods

MICROSWITCHES

NOTE: You can stack two MIC1s to make a DPDT. For more than two switches, use OEM models.

P/N	DESCRIPTION
MIC1	SPDT Microswitch For MCH3 Head

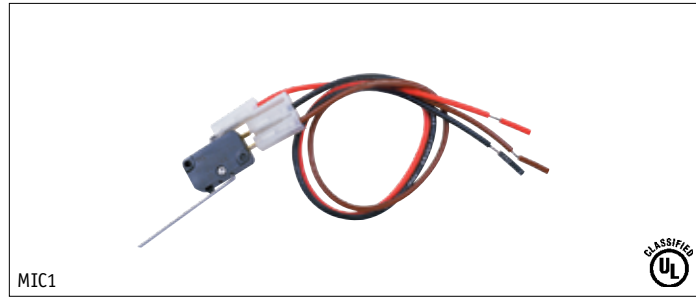

MIC1



CO₂ ACTUATOR CARTRIDGES are UL classified for **Pyro-Chem** and, along with O-rings, must be periodically replaced in accordance with the **Pyro-Chem**® manual. Refer to manual for replacement intervals and installation instructions.

NOTE: Make sure to check cartridge weight before installation

P/N	DESCRIPTION
PCC	16 g CO ₂ Actuator Cartridges, Pkg/3
PC55531	O-Ring Actuator Cartridge



PCC



BRASS FLARE FITTINGS are for system installations and meet SAE J513, as specified in the manufacturer's manual.

NOTE: Tees and connectors do not include flare nuts.

P/N	DESCRIPTION
FC25	1/4", 45° Flare x 1/4" NPT Male Connector
FN25	1/4", 45° Flare Nut
FT25	1/4", 45° Flare Tee
FC13	1/4", 45° Flare x 1/8" NPT Male Connector



FC25

FN25

FT25

COPPER TUBING for **Pyro-Chem**® system installations.

P/N	DESCRIPTION
CT50	1/4" x 50' Copper Tubing (1/32" Wall)



CT50

Easy-to-use, this **FLARING TOOL** efficiently flares tubing ends of seven common sizes (3/16"-5/8").

P/N	DESCRIPTION
TL2880	Flaring Tool



TL2880 In Use

These heavy-duty **TUBING CUTTERS** come with hardened steel reamers and spare cutting wheels.

P/N	DESCRIPTION
ITC1000	Tubing Cutter
1000TC	Tubing Cutter (Domestic)
TCB	Tubing Cutter Blades, Pkg/2



ITC1000

1000TC

In Use photos may show items not included or available separately.

A

- Adapters
 - Battery, 148, 160
 - Brass Hose, 45-46
 - Carry Handle, 243
 - CO₂, Recharge, 193
 - DC, Recharge, 192
 - Grease Tite, 313
 - HydroTest, 196-197, 337
 - I-Beam, 245
 - Recharge, 185, 332
 - T-Handle, 332
- Addressable
 - Duct Detectors, 127, 133
 - Modules, 128
 - Pull Stations, 128
 - Smoke Detectors, 127
- Adhesive
 - Remover, 202
 - Spray On, 167, 202
- Adhesive Tape
 - Duct, 204
 - First Aid, 101
 - PTFE, 112, 201
- AED
 - Cabinets, 107
 - Defibrillators, 106-107
 - Replacement Parts, 106, 108
 - Signs, 108, 170
- Aerosols, 139-140, 202, 305
- AFFF Foam, 58
- Air
 - Blow Gun, 185
 - Canned, 140, 202
 - Gauge, 115
 - Horn, 64
 - Hose, 185
 - Hose Reel, 185
 - Pump, Hydrostatic Test System, 194
 - Valves, 192
- Alarm
 - Batteries, 129, 147-148, 158-160
 - Bells, 122, 138, 323
 - Break Glass Cover, 136
 - Covers, 136
 - Guard, 122, 147
 - Panels, 124-126
 - Pull Stations, 128, 135-136
 - Signs, 113, 169, 171
- Alarms
 - Cabinet, 32
 - Carbon Monoxide, 132, 146-147
 - Exit Door Lock, 157
 - Exit Stopper, 157
 - Fire Extg Theft Stopper, 32
 - Heat, 144
 - Smoke, 143-146
- Alcohol Wipes, 102
- Alkaline Batteries, 158-159, 216
- Amerex
 - Extinguishers, 8-16
 - Pictograms, 249-257
 - Service Manual, 332
 - System Parts, 330-333
- Anchors, Concrete, 200
- Angle Valves, 117
- Annunciators, Remote, 125
- Ansul
 - Pictograms, 258-267
 - System Parts, 334-339
- Antifreeze, 12, 20, 24, 184
- Antiseptics, 103
- Apparel/Welding, 72
- Appliance Cleaners, 305
- Apron, Denim, 78
- Axes, 45, 57

- B**
 - Backpack Extg System, 58
 - Back Supports, 65
 - Badger
 - Extinguishers, 17-21
 - Pictograms, 268-277
 - System Parts, 340-343
 - Bags
 - Blow-Out, 188
 - Gear, Firefighters, 52
 - Powder Pail, 188
 - Tool, 213
 - Ball Valves, 120, 187
 - Balloons, System Test, 303
 - Bandages, 100-101
 - Bands, CO₂, 243
 - Barricade Tape, 55, 80
 - Batteries
 - Alarm Panel, 129, 148
 - Alkaline, 158-159, 216
 - BAT Series Replacement, 148, 159-160
 - Lantern, 158
 - Lead Acid, 159
 - Lithium, 147, 158, 217
 - NiCad, 158
 - Power Rite, 148, 159-160
 - Power Sonic, 148, 159-160
 - Pure-Lead, 159
 - Battery
 - Adapter, 148, 160
 - Analyzers, 141, 162
 - Leads, 160, 163
 - Tester, 141, 162
 - Bells, Alarm, 122, 138, 323
 - Bench
 - Beam Scale, 190
 - Vise, 187
 - Beverage Cylinder
 - Carry Handle, 243
 - Regulators, 243
 - Bin Boxes & Racks, 215, 229, 233
 - Bio Med Wash, 103
 - Biohazard
 - Bags, 100
 - Container, 100
 - Kit, 100
 - Black Pipe
 - Fittings, 319
 - Nipples, 115, 318
 - Plugs, 115, 319
 - Blankets, 66-67, 104-105
 - Blow Gun, 185
 - Blow-Out Bag, 188

Booster Hose, 40, 56
 Boots, 52, 78-79, 307
 Box
 Document Storage, 88
 Gas Valve, 322
 Group Lock, 83
 Junction, 338
 Nipple Tote, 111, 317
 Tool, 163, 214
 Brackets
 Extinguisher, 245-247
 Forklift, 246
 Fusible Links, 311, 345, 348
 Safety-Set, 305
 Stand Off, 311, 317
 System, 330, 340, 344
 Brass
 Adapters, 45-46
 Bushings, 46
 Caps, 46, 121
 Fittings, 45-46, 333, 343
 Hose Valves, 47-48, 117-118
 Nipples, 46, 193
 Nozzles, 41-42
 Plugs, 47, 121
 Reducers, 45
 Snoots, 46
 Break Caps, 47, 121
 Break Glass Cover, Alarm, 136
 Break Rods
 Alarm Pull, 136
 Pyro-Chem Remote, 348
 Breaker Bar & Hammer, 27, 32, 34
 Briefcase/Portfolio, 214
 Brushes, 112, 198
 Bubble Covers, 33
 Bucket Boss, 213
 Buckeye Pictograms, 278-281
 Bug Remedies, 103
 Bulbs, 161
 Burn Products, 105-106
 Bursting Discs, 339
 Bushings, 237, 319-320

C

Cabinet
 Accessories, 32
 AED, 107
 Alarms, 32
 Covers, 27, 33
 Fire Blanket, 66-67
 Fire Extinguisher, 26-31
 Key Box/Set, 35
 Labels/Decals, 33
 Locks, 27, 30, 33-35
 Safety Storage, 86-88
 Sprinkler Head, 111
 CABINETS, ACCESSORIES, &
 COVERS, 25-36
 Cable
 Block, 322
 Crimps, 312
 Cutter & Crimper Tool, 312
 Fire Alarm, 142
 Stainless Steel, 312
 Ties, 85
 Cages, Sprinkler, 110
 Cam Lock, 35
 Canned Air, 140, 202
 Canned Smoke, 139
 Cans
 Safety, 89-90
 Waste, 91
 Capillary Tees, 130
 Caps
 Blow-Off, 335, 337
 Brass, 46, 121
 Break, 47, 121
 Cylinder, 61, 188
 Plastic, 47, 121, 321
 Shipping, 237, 334
 Carbon Monoxide Alarms, 132, 146-
 147
 Cargo Bar, 61, 215
 Cart
 Dolly, 13, 248
 Utility, 215

Cartridge
 Actuator, 340, 343-344, 349
 Bushings, 237
 Filling Bonnet, 236
 Hydrotest Adapter, 197
 Nitrogen, 330, 334, 340
 Shipping Caps, 237, 334
 Smoke, 303
 Caulk, Fire-Rated, 304
 Certificate of Inspection, 329
 Chain, Double Jack, 112
 Chain Reel, 184
 Chemical
 Antifreeze, 12, 24, 184
 Extinguisher, 24, 184
 Foam, 58
 Recharge, 24, 184
 Wet, System, 330, 334, 337, 341,
 344
 Chrome
 Fittings, 320
 Sleeving, 317
 Cigarette Butt Receptacles, 91
 Circuit Breaker Lockouts, 82
 Cleaners
 Fryer, 305
 Grill, 305
 Hand, 77, 103, 203
 Multi-Purpose, 202
 Oven, 305
 Stainless Steel Polish, 305
 Clothing
 Apron, 78
 Coveralls, 73, 307
 Hood, 51
 Rainsuit, 79
 Suspenders, 52
 CO₂
 Actuator Cartridges, 340, 343-344,
 349
 Bands, 243
 Beverage Regulators, 243
 Carry Handles, 243
 Clips, 242

- Cylinder Caps, 61, 188
- Extinguishers, 11, 16, 19-21
- Filling Bonnet, 236
- Handles, 240
- Horn Holder, 241
- Horns, 240
- Hose Continuity Tester, 211
- Hoses, 241
- Nipples, 240
- Recharge Equipment, 186-190
- Safety Discs & Washers, 240
- Siphon Tubes, 185, 239
- Straps, 242
- Transfer Pump, 192
- Valve Pictograms, 297
- Valve Stems, 229
- Valves, 237-239
- Codes/Regulations, 60, 308
- Coiled Hose, 185
- Collars, VOS, 180
- Concrete Anchors, 200
- Condemned Tag, 181
- Conductivity Test Label, 176
- Conduit Fittings, 312
- Contactors, Electrical, 323
- Continuity Tester, 211
- Control Modules, Fire Alarm, 128
- Control Panels, Fire Alarm, 124-126
- Copper Tubing, 333, 343, 349
- Corner Pulleys, 315-316, 331, 335, 338, 341, 345, 348
- Coveralls, 73, 307
- Covers
 - Alarm, 136
 - Boot/Shoe, 72, 78, 307
 - Bubble, 33
 - Cabinet, 27, 33
 - Drum, 91
 - Extinguisher, 36
 - Fire Hydrant, 36
 - Rack & Reel, 44
 - Tag, 182
 - Vinyl, 36, 44
 - Wheel Unit, 36
- CPR/Biohazard Supplies, 99-100
- Crimps & Crimping Tools, 312
- Custom Sign Order Form, 173
- Custom Signs, 172
- Cutters, 207, 312, 324, 326, 333, 349
- Cutting Lubricant Stick, 324
- Cylinder
 - Cap, 61, 188
 - Dryer, 195
 - Floor Vise, Pneumatic, 193
 - Inspection Lights, 195
 - Inspection Mirrors, 196, 198
 - Lockers, 89
 - Rack System, 61
 - Stamp Sets, 198
 - Tag, 181
 - Test w/ Master Gauge, 194
 - Test Labels, 177
- Cylinders, 330, 340, 344
- D**
- DACT, 126
- Danger Signs, 169
- Decals, 33, 131
- Defibrillator Replacement Parts, 106, 108
- Defibrillators, 106-107
- De-icer, 202
- Detector Assembly, 331
- Detectors
 - Addressable, 127
 - Carbon Monoxide, 132
 - Duct, 127, 133
 - Heat, 134, 310
 - Leak, 199
 - Smoke, 127, 129, 132
 - System, 331, 335, 341, 345
 - Tester, 138-139, 202
 - Waterflow, 122, 134
- Discs, Bursting, 339
- Dispenser
 - Barricade Tape, 55, 80
 - Hand Sanitizer, 77, 103
 - Wipes, 77, 203, 306
- Dispensing Bottle, 90
- Disposable Gloves, 76, 102, 108
- Document Storage Box, 88, 142
- Dolly Cart, 13, 248
- Door(s)
 - Duct Access, 304
 - Holder, Fire, 137-138
 - Lock, Exit, 157
 - Pouch, 61
- DOT
 - Labels, 175-176
 - Stamps, 197
 - Supplies, 61
- Double Jack Chain, 112
- Drill
 - Bits, 209, 325
 - Vari-Bit Step, 325
- Drills, 324
- Drum
 - Covers, 91
 - Funnel, 91
 - Wrench, 90
- Dry Chemical
 - Extinguishers, 8-9, 11, 18, 21
 - Gaskets, 231
 - Gauges, 226
 - Powder, 24, 184
 - Recharge Kit, 191
 - Valve Stems, 227-229
 - Wheeled Unit Hose, 241
- Dryers, Cylinder, 195
- Dual Gauge Assembly, 195
- Duct
 - Access Doors, 304
 - Detector Test Tool, 140
 - Smoke Detectors, 127, 133
 - Tape, 204
- Dust Masks, 74, 188

E

Ear Plugs & Muffs, 74
 Eductors, Foam, 58
 Elbow Sleeve, 213
 Elbow Support, 213
 Electric Hose Tester, 41
 Electrical Contactors, 323
 Electrical Tape, 204
 Electrical Tester, 162
 Electronic Digital Scale, 190
 Emergency
 Blanket, 66-67, 104-105
 CPR/Fluid Barrier Kit, 99
 Exit Signs, 150-153, 168, 170
 Fluorescent Pack, 156
 Light Cross Reference Guide, 164
 Light Parts Tray, 163
 Light Test Button Pick, 162
 Lights, 152-157
 Preparedness Kits, 67
 Response Guidebook, 60
 Roadside Kit, 63
 EMERGENCY RESPONSE
 PRODUCTS, 49-58
 Epoxy, 177
 Escutcheons, 111, 120
 Exit
 Door Lock, 157
 Signs, 150-153, 168, 170
 Stopper, 157
 EXIT & EMERGENCY LIGHTING,
 149-164
 Expansion Rings, 40
 Extinguisher
 Alarms, 32
 Cabinets/Covers, 26-31, 33
 Signs, 34, 166-167
 Stands, 28-29, 248
 Vinyl Covers, 36
 Extinguishers, 8-22
 Eye Care Products, 71, 104-105
 Eye Protection, 51, 69-70
 Eyewash, 71, 104-105
 Eyewash Inspection Tags, 71

Eyewear Lanyard, 71
 E-Z Anchors & Toggles, 201
 E-Z Fill Siphon, 185, 328, 337, 347

F

Face Shields, 68
 Fall Protection, 81
 Fasteners
 Anchors, 200-201
 Quick Mount, 314, 325
 Seal, 314
 Tag, 182
 Fiberglass Extinguisher Stand, 29,
 248
 Fill Systems, DCX, 187
 Filling Bonnet, 236
 Filter
 Grease, 302
 Hood, 302
 Locking Handles, 302
 Spacers, 303
 Finger Cots, 102
 Fire
 Alarm Bells, 122
 Alarm Cables, 142
 Alarm Signs, 169
 Alarms, 124-126, 135-137
 Axes, 45, 57
 Blankets, 66-67, 104-105
 Boots, 52
 Dept Connections, 120
 Dept Fittings, 45-47
 Dept Foam, 58
 Dept Lockbox, 35
 Dept Nozzles, 58
 Dept Tools, 45, 57
 Document Box, 142
 Door Holders, 137-138
 Extinguisher Brackets, 245-247
 Extinguisher Chemical, 24, 182
 Extinguisher Signs, 12, 34, 166-167
 Extinguisher Stands, 28-29, 248
 Extinguishers, 8-22
 Gloves, 50

Helmets, 51
 Hood, 51
 Hose, 38-40, 56
 Hose Couplings, 40
 Hose Covers, 44
 Hose Hangers, 43
 Hose Nozzles, 41-42, 58
 Hose Racks, 43
 Hose Reels, 43
 Hose Signs, 169
 Hose Testing Equipment, 41
 Hose Tote Straps, 40, 56
 Hose Valves, 47-48, 58, 117-118
 Retardant, 66
 Training Torch Kit, 216
 FIRE ALARM PRODUCTS, 123-148
 FIRE EXTINGUISHER PARTS, 225-
 300
 FIRE EXTINGUISHERS &
 CHEMICAL, 7-24
 FIRE HOSE, NOZZLES, BRASS, &
 HOSE VALVES, 37-48
 Fireboy
 Accessories, 23
 Extinguishers, 22
 First Aid
 Bug Remedies, 103
 Burn Relief, 105-106
 Cabinets, 92-93
 Cream/Ointments, 103
 Eyewash, 71, 104-105
 Finger Cots, 102
 Gauze, 101
 Gloves, 76, 102, 108
 Hot Packs, 104
 Ice Packs, 102, 104
 Instruments, 104
 Kits, 93-99
 Medications, 101
 Signs, 71, 96, 105, 170
 Sprays, 104
 Supplies, 71, 92-108
 Tape, 101
 Wash, 103

Wipes, 102-103
 Wraps, 101
 Fittings
 Black Pipe, 319
 Brass, 45-46, 343, 349
 Chrome Pipe, 320
 Conduit, 312
 EMT, 315
 Flare, 333, 343, 349
 Tote Tray, 111, 320
 Flag Pictograms, 282-283
 Flag Seals, 234-235
 Flags, Traffic, 64
 Flame-Resistant
 Coveralls, 73
 Jeans, 73
 Shirts, 73
 Flame Retardant, 66
 Flame Safe Caulk, 304
 Flare Container, 64
 Flares, 64
 Flaring Tool, 209, 326, 333, 349
 Flashlights, 52-55, 218-223
 Flexible Conduit, 336, 346
 Florida Truss Signs, 174
 Foam
 AFFF, 58
 AR-AFFF, 12-13, 24
 Eductors, 58
 Extinguisher, 13, 19
 Nozzle, 58
 Foam Adhesive Tape, 112
 Fog Nozzles, 41-42, 58
 Forestry Hose, 40, 56
 Forklift Bracket, 246
 Form(s)
 Holder, 61, 64, 88, 212, 329
 Inspection, 61, 329
 Fryer Panels, 302
 Funnels, 89, 185
 Fusible
 Link Brackets, 311, 345, 348
 Link Hangers, 345
 Links, 309-310

G

Gas
 Labels, 175-176
 Valves, 321, 332, 336, 341, 346
 Valve Box, 322
 Valve Kit, 322
 Gate Valves, 48, 57, 118
 Gated Wye, 47, 57
 Gauge(s)
 Cap, 56
 Certified Test, 195
 Clean Agent, 226
 Dry Chemical, 226
 Dual Assembly, 195
 Line, 56
 Pitot, 56
 Recharge, 188
 Regulator, 243
 Sprinkler, 115
 Tester, Water Extg, 199
 Valve, Three-Way, 115, 189
 Water Based Extinguisher, 226
 Wrench, 199, 226
 Gauze, 101
 Gear Bag, Firefighter's, 52
 General Pictograms, 284
 Glasses, Safety, 69-70
 Gloves
 Fire, 50
 First Aid, 76, 102, 106
 Latex, 76, 102
 Neoprene, 307
 Nitrile, 76, 102, 106
 Welding, 72
 Work, 75-76
 Glow-In-The-Dark
 Lightsticks, 64
 Signs, 96, 151, 170
 Goggles, 51, 70-71, 307
 Grabbers, 214
 Grease
 Comb, 305
 Filters, 302
 Scraper, 327

Silicone, 231, 339

Guards

Alarm Bell, 122, 147
 Cylinder Valve, 61, 188
 Exit Sign, 156
 Hood Light, 303
 Pull Station, 328
 Smoke Alarm, 147
 Sprinkler Heads, 110

H

Hacksaw, 209
 Halon
 Extinguishers, 10
 Gauges, 226
 Valve Stems, 228-229
 Halotron I Extinguishers, 10, 15, 19
 Hammers, 198, 207
 Hand
 Cleaners, 77, 103, 203
 Sanitizer, 77, 103
 Soap, 203
 Truck, Single Cylinder, 215
 Wipes, 77, 103, 203
 Handles
 CO₂ Carry, 243
 Grip, Valve, 193
 Rubber CO₂, 240
 Handwheels, 48, 118
 Hanger Loop Kit, 244
 Hanger(s)
 Fusible Link, 345
 Hose, 43
 Wall, 244
 Hanging Scales, 190
 Hard Hat Lanyards, Coiled, 69
 Hard Hats, 68
 Harness, 81
 Hazard Signs, 176
 Head Protection, 68
 Headlamps, 54, 218
 Headlights, 54, 217
 Hearing Impaired Smoke Alarm, 146
 Hearing Protection, 74

Heat
 Alarm, 144
 Detector Tester, 138-139
 Detectors, 134, 310
 Height Indicator, 170
 Helmets
 Firefighting, 51
 Hard Hats, 68
 Hex Tools, 208
 Hole
 Cutters, 324
 Punch Holder, 184, 211
 Punches, 184
 Saws, 325
 Holsters, 211
 Hood
 Adapters, Grease Tite, 313
 Caulks, 304
 Duct Access Doors, 304
 Filters, 302
 Grease Scraper, 327
 Installation Tool, 314
 Light, 303
 Nomex Firefighting, 51
 Patch Seals, 313
 Signs, 329
 Horn(s)
 Air, 64
 CO₂, 240
 Holder, 241
 Strobe, 323
 Hose
 Air, 185
 Booster, 40, 56
 Clip, 242
 CO₂, 241
 Continuity Tester, CO₂, 211
 Couplings, 40
 Covers, 44
 Electric Tester, 41
 Fire, 38-40, 56
 Gaskets, 40
 Hanger, 43
 Hump Rack, 44

Nitrogen, 188
 Nozzles, 41-42, 58
 Racks, Pin, 43
 Reels, 43, 185
 Rings, 40
 Straps, 241-242
 Tote Strap System, 40, 56
 Valves, 47-48, 57, 117
 Hot Packs, 104
 Hump Racks, 44
 Hydrant
 Cover, 36
 Flow Test Kit, 56
 Valves, 47-48, 57, 118
 Wrenches, 45, 57
 Hydro Aid Complete, 194
 Hydrostatic Test System, Air Pump,
 194
 Hydrotest
 Adapters, 196-197, 337
 Labels, 177
 Pump, 194

I
 Ice Packs, 102, 104
 Industrial Mat, 85, 306
 Infrared Laser Thermometer, 308
 Insect Sting Itch Relief, 103
 Inspection
 Certificate, 329
 Forms, System, 329
 Lights, 195
 Mirrors, 196, 198
 Tags, 71, 181-182
 Vehicle Report, 61
 Installation Tool, 314, 325

J
 Jeans, Flame-Resistant, 73

K
 Key Box/Set, 35
 Key Chain Reel, 184
 Kidde
 Pictograms, 285-294
 System Parts, 340-343
 Kits
 Bloodborne Pathogen, 100
 Bodily Fluid Clean-Up, 99
 Burn, 106
 Connector, 131
 CPR & Fluid Barrier, 100
 Detector Kit, 335
 Discharge Adaptor, 330
 Dry Chemical Refill, 191
 Emergency Preparedness, 67
 Fire Training Torch, 216
 First Aid, 92-98
 Gas Valve Actuator, 332
 Hanger Loop, 244
 Hydrotest Adapter, 196
 LED Retrofit, 161
 Link Housing Adapter, 311, 348
 Number, 174
 O-Ring Removal, 199
 O-Rings, 231
 Paintball Cylinder Recharge, 193
 Recharge Adapter, 191
 Rivet, 233
 Roadside Emergency, 63
 Service Truck, 187
 Snake Bite, 99
 Sprinkler Gauge Valve, 115
 Stamp, 179
 Start-Up, 191
 Triangle Kit, 63
 Universal Gas Valve, 322
 Valve Stem, 229
 Wheeled Unit, 191
 Knee Pad, 212
 Kneeling Pad, 213
 Knives, 210

L

Labels
 Agent Replacement, 180
 Call For Service, 180
 Composite Retest, 177
 Conductivity Test, 176
 DOT, 175-176
 Extinguisher Operating, 174-175
 Hazmat, 176
 Hydrotest/Maintenance, 177
 Installation, 180
 Lighting Service, 163
 Scraper, 210, 327
 Service, 116, 179
 Sprinkler, 114-115
 Sprinkler Gauge, 115
 Temperature, 311
 Ladders, Escape, 66
 Lanyards, 69, 71, 81, 212
 Laser Thermometer, 308
 Leak Detector, 199
 LED Bulbs, 161
 Lens Cleaning Station, 71
 Level, 211, 327
 Life Vest, 65
 Light(s)
 Cylinder Inspection, 195
 Emergency, 152-157
 Exit, 150-153
 Flashlights, 52-55, 218-223
 Headlamps, 54, 218
 Headlights, 54, 217
 Hood Fixture, 303
 Lanterns, 53, 221-222, 224
 Parts Tray, 163
 Pen, 54, 195, 218-219
 Protector Case, 224
 Remote Area, 222
 Spot, 220, 223
 Sticks, 64
 Strobe, 122, 137, 146, 323
 Work, 221-222
 Line Tester, 117
 Linkage Pliers, 206, 327

Link(s)

Brackets, 311, 345, 348
 Fusible, 309-310
 Hanger, 345
 Housing Adapter Kit, 311
 Resettable, 308
 Test, 309
 Thermal, 308
 Lithium Batteries, 147, 158, 217
 Lock Box, 35, 83
 Lockers, Cylinder, 89
 Locknut Pliers, 207, 322, 328
 Lockout/Tagout, 81-83
 Locks, 33-35, 84
 Lubricant, 202, 231, 324

M

Magnetic Strip Tape, 34, 112
 Mallet, Rubber, 188
 Marine Systems, 22-23
 Marking
 Pens, 199-200
 Tape, 80
 Mask, Dust, 74, 188
 Match Extender, Telescopic, 327
 Mats
 Floor Safety, 85, 306
 System Service, 327
 Measuring
 Tape, 211
 Wheels, 63
 Medicated Sprays, 104
 Medications, 101
 Megaphone, 65
 Metal Stamps, 197
 Microswitches, 331, 335, 338, 341, 345, 349
 Mirrors, Inspection, 196, 198
 Mobile Desk, 65, 212
 Monitor/Control Modules, 128
 Multi-Meter, 140, 162
 Multi-Pliers, 209
 Municipal
 Boots, 52

Foam, 58
 Gear, 50-52
 Gloves, 50
 Hose, 56
 Lighting, 52-55
 Nozzles, 58
 Tools, 57
 Valves, 57

N

NFPA Publications, 60, 308
 NiCad Batteries, 158
 Nipples
 Brass, 46, 193
 Pipe, 115, 318
 Rack, 43
 Tote Box, 111, 317
 Nitrogen Cartridges, 330, 334, 340
 Nitrogen Regulator, 188
 Nitrogen Valves, 239
 Non-Compliance Tag, 181
 Notification Devices, 137
 Nozzle(s)
 Aiming Device, 339, 347
 Caps, 331, 335, 341, 345, 347
 Fire Hose, 41-42, 58
 Systems, 331, 341, 345, 347
 Number Kit, 174
 Nutdriver Set, 208

o
 Oil, Thread Cutting, 326
 Ointments, 103
 O-Ring(s)
 Extinguisher, 230-231
 Kit, 231
 Lubricant, 231
 Removal Kit, 199
 Operating Labels, 174-175
 Oven Cleaners, 305

P

Padlocks, 33-34, 84
 Pail Opener, 186
 Paintball Cylinder Recharge Kit, 193
 Particulate Respirator, 74
 Parts Bin Rack, 215, 233
 Patch Seals, 313
 Pem All Pictograms, 295
 Pen(s)
 Ball Point, 199
 Lights, 54, 192, 218-219
 Marking, 199-200
 Pepper Spray, 65
 PERSONAL PROTECTION &
 SAFETY PRODUCTS, 59-108
 Photo-Luminescent, Exit Signs, 151
 Pick Set, 199
 Pictograms, Miscellaneous, 300
 Pin Racks, 43
 Pipe
 CPVC, 130
 Cutters, 130
 Dope Brush, 112, 198
 Fittings, 319-320
 Nipples, 115, 318
 Sleeving, Chrome, 317
 Thread Sealant, 112
 Threading Machine, 326
 VESDA, 130
 Wrenches, 205, 326
 Pitot Gauge, 56
 Placard, DOT, 61
 Plastic Bottle, 216
 Plastic Sheeting, 307
 Plates, Escutcheons, 120
 Platform Truck, 215
 Playpipe, 41
 Pliers, 206-207, 322, 328, 333
 Plugs
 Black Pipe, 115, 319
 Brass, 47
 Chrome, 320
 Lockout, 83
 Pneumatic Cylinder Floor Vise, 193

Pneumatic Piston, 321, 339
 Polycarbonate Nozzles, 41
 Poncho, Rain, 79
 Powder Pail Bags, 188
 Power Supplies, 129, 141-142
 Pressure Switches, 122, 135
 Protective Boot/Shoe Covers, 72, 78,
 307
 Protective Coveralls, 73, 307
 Protector Case, 224
 PTFE Tape, 112, 201
 Publications
 CFR, 60
 Compliance Guide, 60
 DOT, 60
 Emergency Response Guide, 60
 Fed Motor Carrier, 60
 NFPA, 60, 308
 Pull Pins & Chains, 236
 Pull Station
 Addressable, 128
 Alarm, 128, 135-136
 Guards/Protectors, 136, 328
 Manual, 128, 135-136, 332
 Pull Tabs, 336
 Remote, 336, 338, 342, 346
 System, 332, 336, 338, 342, 346
 PVC Boots, 78, 307
 Pyro-Chem System Parts, 344-349

Q

Quad Rings, 231
 Quick Disconnect Couplers, 192
 Quick Mount Fasteners, 314, 325

R

Rack
 Covers, 44
 Cylinder Drying, 194
 Hump, 44
 Nipples, 43
 Parts Bin, 215, 233
 Pin, 43

System, Cylinder, 61
 Wall Brackets, 43
 Rainwear, 79
 Range Guard System Parts, 340-343
 Recharge
 Adapters, 192
 Antifreeze, 12, 20, 24, 184
 Chemical, 12, 24, 184, 334, 337,
 344
 Equipment, 186-193
 Foam, 13, 19, 24
 Gauge, 188
 Recovery System, 187
 Wet Chemical, 12, 20, 184, 330,
 341
 Reducers, Brass, 45
 Reel Covers, 44
 Reels, 43, 185
 Reflector Triangle Kit, 63
 Regulator
 Beverage, 243
 Nitrogen, 188
 System, 337
 Test Kit, 339
 Remote Annunciators, 125
 Remote Heads, 153, 157
 Remote Pull Station, 336, 338, 342,
 346
 Remote Test Station, 127
 Repair Tag, 181
 Report Holder, 61, 64, 88, 329
 Rescue Tools, 45, 57, 208
 Reset Relay, 323
 Respiratory Protection, 74, 188
 Retardant, Fire, 66
 Rivets, 232
 Roadside Emergency Kit, 63
 Rubber Mallet, 188

S

S-Hooks, 312
 Safes, 85
 Safety
 Cabinets, 86-88

Cans, 89-90
 Discs & Washers, 240
 Fence, 63
 Flare Container, 64
 Flares, 64
 Glasses, 69-70
 Goggles, 51, 70-71, 307
 Knives, 210
 Lockers, 89
 Mats, 85, 306
 Self-Defense Spray, 65
 Set Brackets, 305
 Supports, 65
 Training Posters, 170
 Vests, 51, 79
 Whistle, 65
 Scales, 189-190
 Scoops, 186
 Scrapers, 210, 327
 Screwdrivers, 208
 Seals
 Patch, 313
 Tamper, 116, 234-235
 Self-Defense Spray, 65
 Self-Luminous Exit Signs, 151
 SERVICE EQUIPMENT, 183-224
 Service Manuals, 332, 337, 347
 Sherwood Pictograms, 298
 Shipping Caps, 61, 237, 334
 Shipping Document, DOT, 61
 Shirts, Flame-Resistant, 73
 Shop Towels, 77, 203, 306
 Siamese Connections, 118-119
 Sign On Adhesive, 167, 202
 Signs, 12, 34, 71, 96, 105, 108,
 113-114, 150-153, 166-171, 174
 SIGNS, LABELS, & TAGS, 165-182
 Silicone Grease, 231, 339
 Single Jacket Fire Hose, 38-39
 Siphon Tubes, 185, 239
 Sleeving, Chrome, 317
 Six-Year Maintenance Labels, 177
 Smoke
 Alarm Guard, 147

Alarms, 143-146
 Cartridges, 303
 Detector Tester, 138-140, 202
 Detectors, 127, 129, 132
 Snake Bite Kit, 99
 Snips, 207
 Soap, Hand, 203
 Solvent Cement, 130
 Sound Level Meter, 140
 Spanner Wrenches, 45, 57
 Spotlights, 220, 223
 Sprayers, 216
 Sprays
 Medicated, 104
 Self Defense, 65
 Spring Clip Brackets, 246
 Sprinkler
 Accessories, 120
 Cabinet, Head, 111
 Cages, 110
 Escutcheons, 111, 120
 Gauge Valve Kit, 115
 Gauges, 115
 Heads, 111
 Installation Labels, 115
 Line Labels, 114
 Service Tags & Labels, 116
 Shut-Off, 112
 Signs, Identification, 113-114, 120,
 171
 Supervisory Switch, 122, 135
 Tamper Seals, 116
 Wrenches, 112
 SPRINKLER ACCESSORIES &
 STANDPIPE EQUIPMENT, 109-122
 Stainless Steel Cable, 312
 Stamp
 DOT Identification, 197
 Holder, 198
 Kit, 179
 Number Set, 198
 Stamping Hammer, 198, 207
 Standpipe Escutcheons, 120
 Start-Up Kit, Service, 191

Steel
 Enclosures, 323
 Stamps, 198
 Tanks, 334
 Toe Boots, 78, 307
 Storage
 Cabinets, 86-88
 Case, 233
 Document Box, 88
 Organizer, Portable, 233
 Straight Stream Nozzle, 41
 Strapping Tape, 162
 Strike First Pictograms, 296
 Strobe Light, 122, 137, 146, 323
 Stud Finder, 211
 Superior Pictograms, 299
 Supervisory Switch, 122, 135
 Supports
 Back, 65
 Wrist, 65
 Suspenders, H-Back, 52
 System
 Brackets, 330, 340, 344, 348
 Detectors, 331, 335, 341, 345
 Enclosures, 330, 344
 Holecutting, 324
 Inspection Certificate, 329
 Inspection Form, 329
 Service Mat, 327
 Service Tools, 332, 337, 342, 347
 Signs, 171
 Smoke Cartridges, 303
 Test Balloons, 303
 SYSTEM PARTS, 301-349

T
 Tag Covers, 182
 Tag Fasteners, 182
 Tags, 71, 83, 116, 178-182
 Tamper Seals, 116, 234-235
 Tape
 Adhesive, 101, 204
 Aisle Marking, 80
 Barricade, 55, 80

- Dispenser, 55, 80
 - Double-Sided Foam, 112
 - Duct, 204
 - Electrical, 204
 - Glass Strapping, 162
 - Gun, 204
 - Magnetic, 34, 112
 - Measure, 211
 - Packing, 204
 - PTFE, 112, 201
 - Warning, 55, 80
 - Tee Pulley, 316, 331, 335, 341, 345
 - Telescopic Match Extender, 327
 - Temperature Labels, 311
 - Test Balloons, 303
 - Test Cage, 194
 - Test Cylinder w/ Master Gauge, 194
 - Test & Drain Valves, 117
 - Test Equipment, Hydraulic, 56
 - Test Gauge, Certified, 195
 - Test Link, 309
 - Test Pump, 194
 - Test System, Air Pump Hydrostatic, 194
 - Tester
 - Battery, 141, 162
 - Continuity, 211
 - Electric, Hose, 41
 - Gauge, 199
 - Heat Detector, 138-139
 - Line, 117
 - Smoke Alarm/Detector, 138-140, 202
 - Thermometer, Infrared Laser, 308
 - Thread
 - Cutting Oil, 326
 - Pipe Machine, 326
 - Sealant, 112
 - Tie Hooks, 214
 - Toggle Anchors, 201
 - Tool(s)
 - Aviation Snips, 207
 - Axes, 45, 57
 - Bags & Belts, 213
 - Box, 163, 214
 - Brushes, 110, 198
 - Bushing, 237
 - Core Removing, 192
 - Drill Bits, 209, 325
 - Flaring, 209, 326, 333, 349
 - Grabber, 214
 - Hacksaw, 209
 - Hammers, Stamping, 198, 207
 - Hex, 208
 - Holder, 198
 - Installation, 325
 - Hole Saw, 325
 - Knives, 210
 - Lanyard, 212
 - Magnetic Power Driver, 314
 - Mallet, Rubber, 188
 - Multi-Pliers, 209
 - Nutdrivers, 208
 - Pipe Threading Machine, 326
 - Pliers, 206-207, 322, 327-328
 - Rescue, 45, 57, 208
 - Screwdrivers, 208
 - Sets, 205, 208-209
 - Straight Snips, 207
 - System Service, 332, 337, 342, 347
 - Torpedo Level, 211, 327
 - Wiring, 163, 206
 - Wrenches, 45, 57, 90, 112, 199, 204-206, 237, 314, 326
 - Tourniquet, 92, 99
 - Towels, Shop, 77, 203, 306
 - Traffic
 - Cones, 62
 - Cones, Collapsible, 63
 - Delineator, 62
 - Flags, 64
 - Flares, 64
 - Light Baton, 64
 - Lightsticks, 64
 - Triangle Kit, 63
 - Vests, 51, 79
 - Training Torch Kit, 216
 - Transfer Cans, 89-90
 - Transfer Pump, CO₂, 192
 - Triangle Kit, 63
 - Trigger Sprayers, 216
 - Truck, Platform, 215
 - Truss Signs, 174
 - Tubes, Siphon, 185, 239
 - Tubing, Copper, Polyethylene, 131, 333, 343, 349
 - Tubing Cutter, 316, 326, 333
- U**
- Unitized, First Aid, 98-99
 - Utility
 - Cart, 215
 - Cutter, 207
 - Knives, 210
 - Scales, 190
- V**
- Vacu-Fill Parts, 186
 - Vacu-Fill Systems, 186
 - Valve Stems, 227-229
 - Valve(s)
 - 3-Way, 115, 189
 - Air, 192
 - Angle, 47-48, 117
 - Ball, 120, 187
 - CO₂, 237-239
 - Flip, 193
 - Gas, 321, 332, 336, 341, 346
 - Gate, 48, 57, 118
 - Gated Wye, 47, 57
 - Globe, 117
 - Guard & Cap, 61, 188
 - Handle Grip, 193
 - Handwheels, 48, 118
 - Hose, 47-48, 57
 - Hydrant, 48, 118
 - Lockouts, 81-82
 - Municipal, 57
 - Nitrogen, 239
 - Quick Release, 239
 - Replacement Parts, 48, 118

Test & Drain, 117
 Wheeled Unit, 238
 Vehicle Brackets, 245-247
 Vehicle Inspection Report, 61
 Verification of Service Collars, 180
 VESDA
 Aspirator, 129
 Capillary Tees, 130
 Decals, 131
 Detector, 129
 Expansion Card, 129
 Filter, 129
 Imager, 129
 Pipe, 130
 Pipe Cutters, 130
 Power Supply, 129
 Solvent Cement, 130
 Vests
 Life, 65
 Safety, 79
 Traffic, 51, 79
 Vinyl Covers, 36, 44
 Vise, Bench, 187
 Vise, Pneumatic Cylinder Floor, 193
 Voltage Probe, 162

W

Wall Anchors, 201
 Wall Bracket, Pin Rack, 43
 Wall Hangers, 244
 Warning Tape, 55, 80
 Washers, 192-193, 201
 Waste Can, 91
 Water
 Extinguishers, 12-13, 20
 Gauges, 115, 226
 Waterflow Detectors, 122, 134
 Water-Jel Burn Products, 105-106
 Weights, Class 7, 190
 Welding Apparel, 72
 Welding Gloves, 72
 Wet Chemical
 Charges, 12, 20, 184
 Wet System Parts

Amerex, 330-333
 Ansul, 334-339
 Badger, 340-343
 Kidde, 340-343
 Pyro-Chem, 344-349
 Range Guard, 340-343
 Wheel Chocks, 62
 Wheeled
 CO₂ Unit Horn Assy, 241
 CO₂ Unit Hose, 241
 Fire Extinguishers, 13-16, 21
 Unit Covers, 36
 Unit Service Kit, 191
 Unit Valves, 238
 Whistle, Safety, 65
 Wildland Backpack
 Extinguishing System, 58
 Wipes, 77, 103, 203, 306
 Wire
 Brush, 198
 Connectors, 163
 Cutter, 163, 207
 Tools, 163, 206
 Wraps, First Aid, 101
 Wrenches
 Adjustable, 205
 Cap, 204
 Drum, 90
 Gauge, 199, 226
 Hydrant, 45, 57
 Pipe, 205, 326
 Ratcheting, 314
 Slip Joint, 204
 Spanner, 45, 57
 Sprinkler, 112
 Storz, 45, 57
 Torque, 205, 237
 Wrist Support, 65