

- Folding Shower Seat
- African Teak Slats

### Product Materials

**FRAME:** 1" dia. 18 gauge stainless steel tubing. Welded.

**WALL BRACKET:** 16 gauge stainless steel with stainless steel piano hinges.

**RETAINING BRACKET:** 16 gauge stainless steel. Positive bullet-type catch holds seat securely in up or down position.

**SEAT:** three handrubbed African teak slats, each 1/2" thick and 4" wide with rounded edges.

### Operation

Hinged seat folds up and out of the way when not in use. When properly installed, seat can support up to 250 lbs. – static load.

### Installation

Verify all rough-in dimensions prior to installation. Provide concealed backing or anchors as specified by architect before finished wall is applied. Secure to wall with mounting screws (included) at holes provided. Locate mounting holes 16 1/16" above finished floor for comfortable adult use.

### Guide Specification

Folding African teak shower seat shall be fabricated of 1/2" thick handrubbed teakwood slats secured to a stainless steel frame of 1" diameter, 18 gauge tubing. Wall bracket of 16 gauge stainless steel with heavy duty hinges.

Overall dimensions: 17"W x 16"H x 1 1/2" thick.

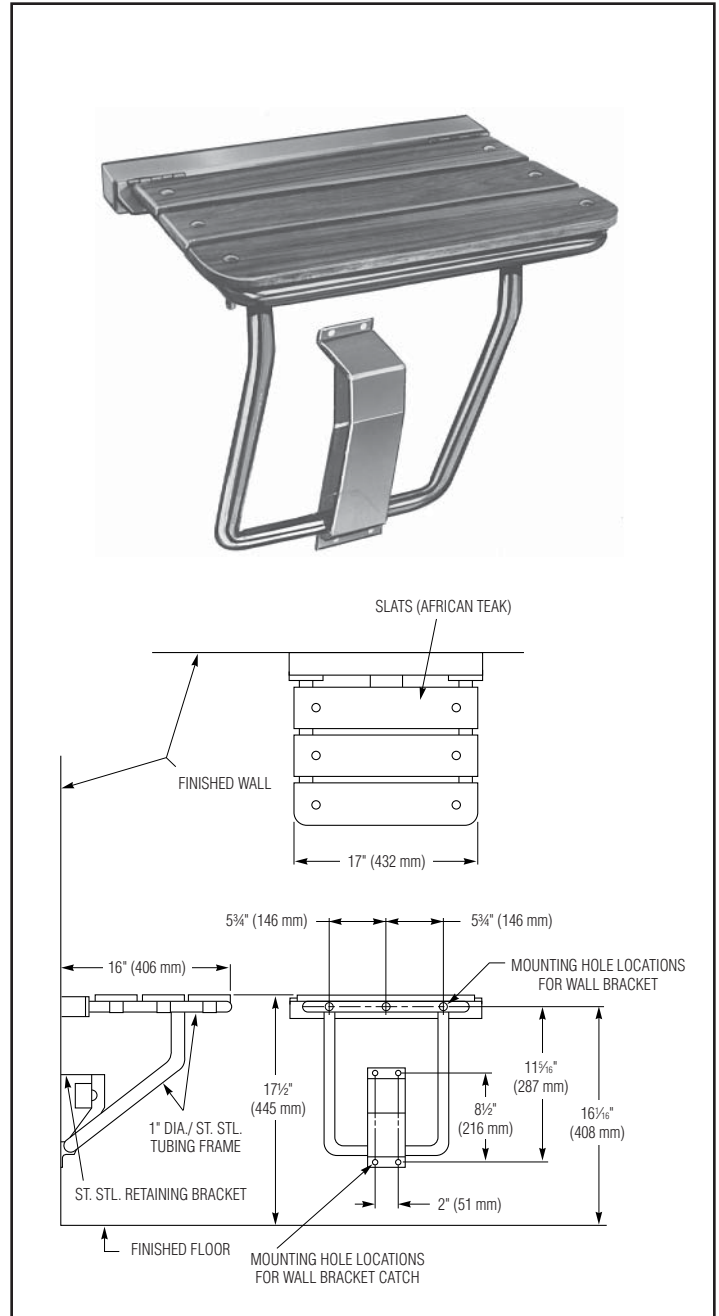

**Washroom Accessories  
Document No. 9005**