

INSTALLATION INSTRUCTIONS

SureFlo® SOAP DISPENSING SYSTEM











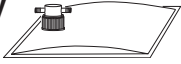

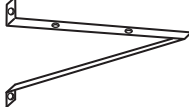
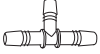











Bobrick SureFlo Soap Dispensing System Soap Cabinets, Soap Dispensers and connections are available from all Bobrick Distributors. Bobrick SureFlo Soap is available only from limited authorized Bobrick SureFlo Soap Dispensing System Distributors.





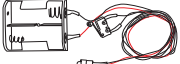



B-830 Soap Cabinet Installation..... Pages 2-8
Prior to beginning installation, read instructions and familiarize yourself with parts and procedure.



Parts List

Items Included			Purchase Separately		
Part #	Description	Qty.	Part #	Description	Qty.
830-306	Bladder Assembly 	1	830-341	Soap Pump Conversion Kit <i>(Items Included in Kit)</i>	1
830-57	Drip Tray 	1	830-313	Vertical Tube 10" Length 	1
830-278	Brackets 	2	830-311	Tee, 3-Barb 	1
830-207	Hardware Packet <i>(Items Included in Packet)</i>	1	830-312	Reducing Connector, 3-Barb 	1
687-6	Spacer 	1	830-72	Intermediate Tube 50" Length 	1
830-242	Adhesive Tape 	1	830-28	Cable Support 	2
1000160	Toggle Bolt 	6	124-62	Cable Tie 	2
1000085	Stud Screw 	6	528-19	Screw Packet 	1
5067-11	Washer 	6	830-162 Tubing 25' Length 	1	
232-11	Hex Nut 	2	822-408 Long Shank <i>for Countertops more than 1-3/4" (45mm) Thick</i>	1	
576-181	Lock Washer 	2	830-359 Soap Pump Assembly with Shank 4" Spout <i>(Items Included in Assembly)</i>	1	
24-17	BobKey 	1	830-355	Soap Pump 	1
830-113	Inline Tubing Connector 	1	8221-402	Short Shank 	1
830-16	Snapper Clamp 	2	830-372 Soap Pump Assembly with Shank 6" Spout <i>(Items Included in Assembly)</i>	1	
830-319	Light Switch Indicator (LSI) 	1	830-356	Soap Pump 	1
			8221-402	Short Shank 	1

Tools Required

<p>Drill</p> 	<p>Pliers</p> 	<p>Level</p> 	<p>PVC Cutter or Hack Saw</p> 
<p>Drill Bits 5/8" diameter for Toggle bolt 3/16" diameter for Stud Screw Masonry Bit for Tile</p> 	<p>Tape Measure and Pencil</p> 	<p>Screw Drivers Phillips Slotted #2 and #3</p> 	<p>Utility Knife or Cutter</p> 

Cabinet Installation

1. Tape Template to desired position and mark holes as indicated:

Cabinet can be installed on left or right side of wall. Clearance: If cabinet is mounted under soap pump, allow 5" (130mm) under top surface of counter for shank extension connection.

Thick Countertop Installer Note:

If counter top is more than 1-3/4" (45mm) thick and a 6" (150mm) shank (Part No. 822-408) is used, 8" (205mm) clearance under top surface of counter is required.

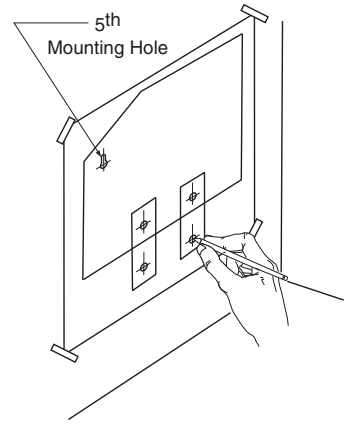

2. Drill 5/8" holes as marked by template.

If drilling into stud, drill 3/16" hole. Provide adequate backing where necessary.

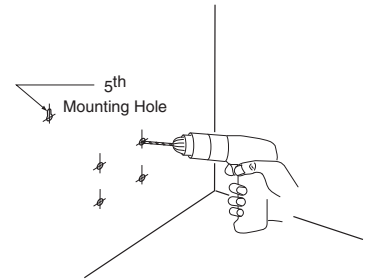

3. **Important:** Keep bolt loose until cabinet has been placed on brackets.

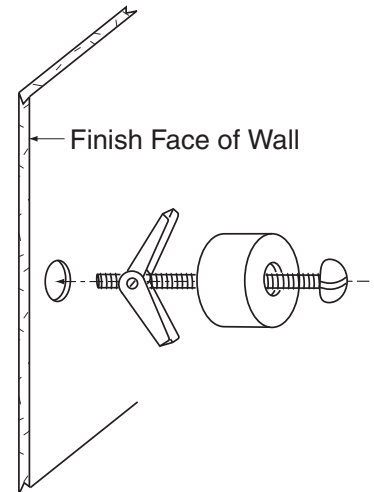

4. Attach Brackets to Wall with Toggle Bolts (supplied). Use a level to ensure brackets are leveled horizontally.

*** For Tile Only:** Bottom 2 toggle bolts can be replaced with #10 screws and blue anchors (not provided).

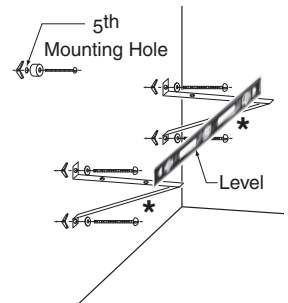

5. Route tubing through hole in cabinet side panel or back wall.

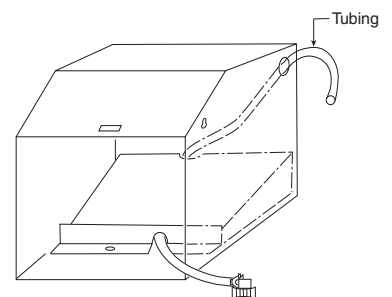

Cabinet Installation cont'd

6. Place double sided adhesive tape on top of back bracket and remove protective strip from adhesive.

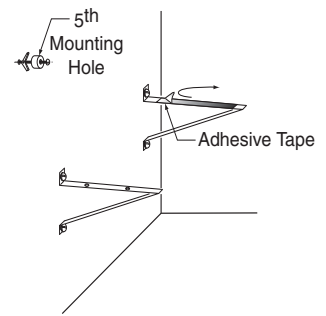

7. Without lowering the back of the cabinet. Place Cabinet on front Bracket aligning weld studs on bottom of cabinet through holes in front bracket and gently place back of cabinet on the back bracket which has the adhesive tape.

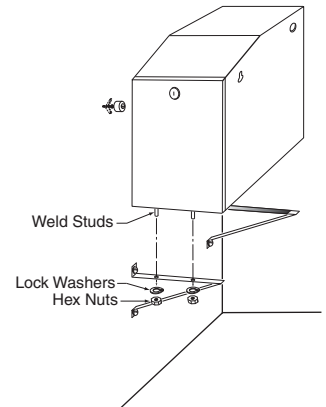

8. Place 2 lock washers and 2 hex nuts supplied on the weld studs on bottom of cabinet and tighten to secure cabinet to front bracket.

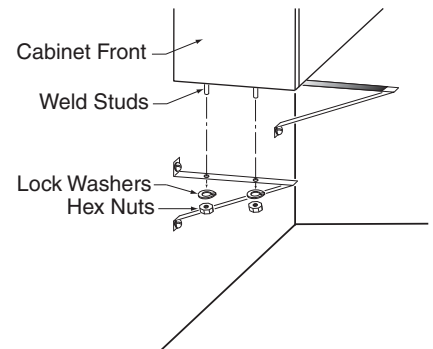

9. To secure cabinet to wall, insert 5th Toggle Bolt head through key hole located at top side of cabinet. Slide bolt head through top of keyhole and tighten.

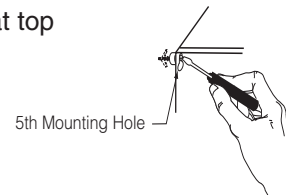

10. Hook up. Low Soap Indicator (LSI) Light.

Connect two "C" sized batteries (supplied) to battery connector. Place clear lens through the hole from outside of cabinet. Insert Black retaining ring on clear lens. Insert LED (Red Light) from the inside, through the retainer ring into clear lens.

Note: Red LED Light should flash when the batteries are connected. LED light will stop flashing when reservoir bladder is filled with soap. (Red light may flash for 3-6 hours after SureFlo soap cartridge is connected.)

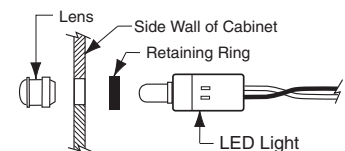

Tubing Connections and Soap Pump Installation (Existing and New Soap Dispensers)

1. Remove Existing B-822 Dispenser pump(s), Soap Bottle(s) and Cap(s), if applicable.

Caution - Black rubber must be between plastic shank and countertop.

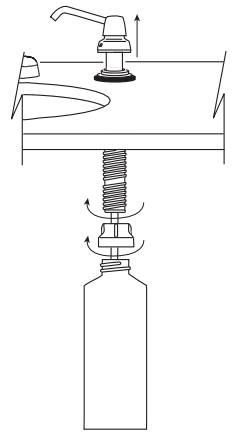

2. If existing B-822 Shank is 6" long, you may cut shank at non-threaded area in the center with a PVC cutter or hack saw, if desired.

Thick Countertop

Installer Note:

If counter top is more than 1-3/4" (45mm) thick, use standard 6" (105mm) shank (Part No. 822-408) without cutting it. 8" (205mm) clearance under top surface of counter is required.

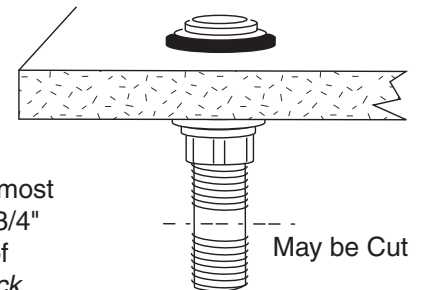

For new installations, mount 8221-408 Short Shank 3" (75mm) for installation in most countertops or 822-408 Long Shank 6" (150mm) for countertops thicker than 1-3/4" (45mm). Make sure countertop surface around mounting hole is clean and free of soap residue. Insert Shank through 1" (25mm) diameter hole. *Make sure the Black Rubber Washer is in place between the countertop and Shank.* Place 822-43 Rosette Washer and Retaining Nut onto Shank under counter top. *Tighten Retaining Nut against underside of countertop.*

Caution: Do not over-tighten Retaining Nut.

3. Connect 830-313 vertical tubes to 3-barb connections of all Soap Pump Cylinders. Make sure tube is completely engaged on the Cylinder fittings.

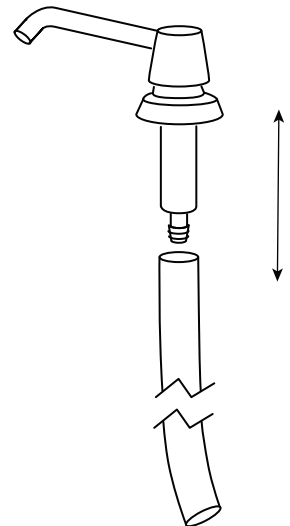

Tubing Connections and Soap Pump Installation (Existing and New Soap Dispensers)

4. Insert soap pump assemblies with vertical tubes into Shanks.

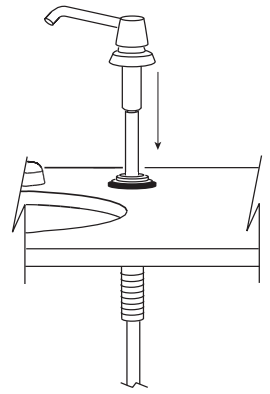

5. Secure the escutcheons by turning clockwise until lock snaps into position. Position Spout over the lavatory.

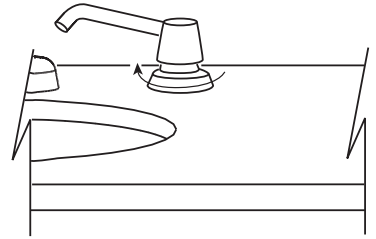

6. Connect Tubing from cabinet to one horizontal arm of 830-311 3-Barb Tee placed under first soap pump in the line. Make sure tube is completely engaged on the Tee fitting.

Note: Excess tubing may need to be cut-off.

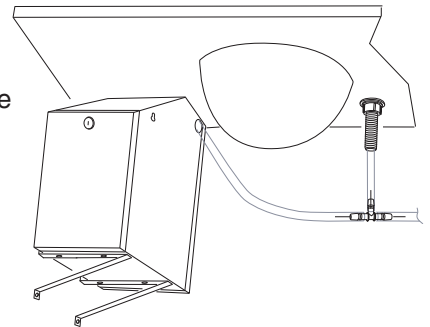

7. Connect bottom end of all soap pump vertical tubes to vertical arms of all Tees except the last soap pump in the line.

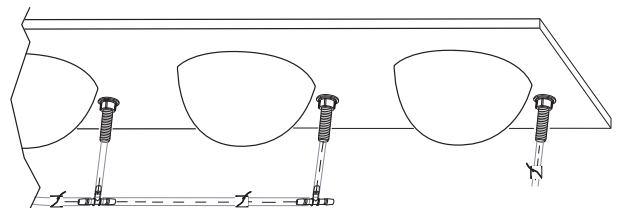

Tubing Connections and Soap Pump Installation (Existing and New Soap Dispensers)

8. Connect a length of 830-72 Intermediate Tubing from the first Tee to the next Tee locations. Cut Tubing to desired length between soap pumps and connect to successive locations except the last soap pump in the line. Make sure tube is completely engaged on the Tee fittings.

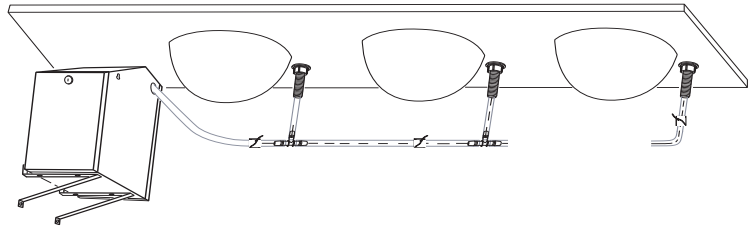

9. Connect intermediate tube to last horizontal arm of Tee at next to last soap pump in the line. Connect 830-312 3-barb reducing connector to other end of last intermediate tube under last soap pump in the line. Connect bottom end of vertical tube of the last soap pump in the line to small end of 830-312 3-Barb reducing connector. Make sure tube is completely engaged on the fittings.

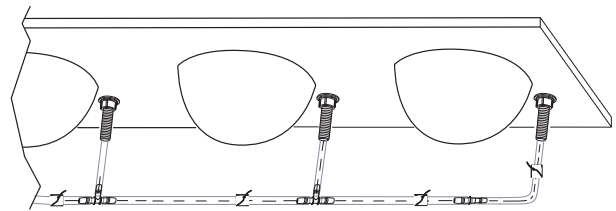

10. Screw Cable Supports into wall between each Soap Pump to support along wall.

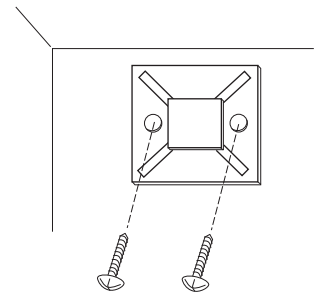

11. Attach intermediate tubing to cable supports with the cable ties between soap pumps

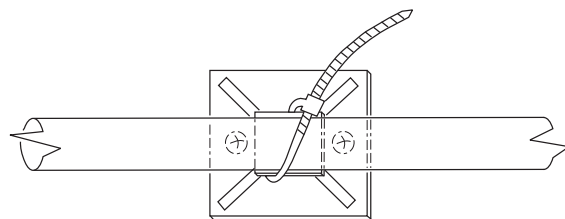

Prime Soap System

1. Place Soap Tank Cartridge into Soap Cabinet and remove protective cover.

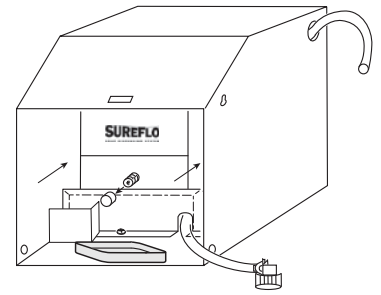

2. Screw Soap Supply Line Cap to Cartridge Outlet by turning clockwise. Soap should flow through the tubing.

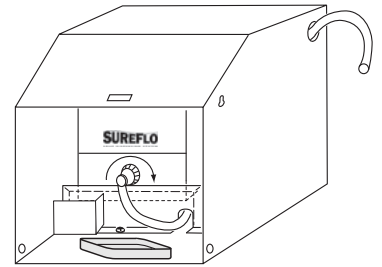

3. Prime Soap System beginning with the dispenser closest to Cabinet until soap is dispensed.

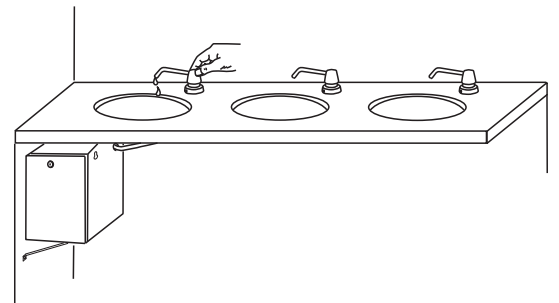

4. Pump each successive dispenser until soap is dispensed and the entire line of tubing is free of air and filled with soap.

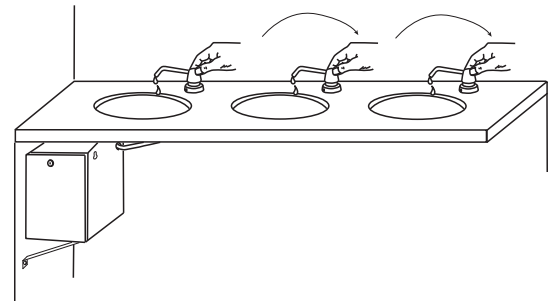



In the United States: BOBRICK WASHROOM EQUIPMENT, INC.

200 Commerce Drive, Clifton Park, NY 12065-1350, Telephone: (518) 877-7444, FAX: 518-877-5029
11611 Hart Street North Hollywood, CA 91605-5882

Washroom Accessories: (818) 982-9600, FAX: (818) 503-1102, e-mail: customerserviceca@bobrick.com
Toilet Partitions: (818) 982-9070, FAX: (818) 503-9287, e-mail: lacspartitions@bobrick.com

In Canada: BOBRICK WASHROOM EQUIPMENT COMPANY

45 Rolark Drive, Scarborough, Ontario M1R 3B1

Ontario East: (877) 423-6555, FAX (877) 423-8555 Email: customerserviceeca@bobrick.com
Manitoba West: (877) 423-444, FAX (877) 423-8444 Email: customerservicewca@bobrick.com

SureFlo® is a trademark of Bobrick Washroom Equipment, Inc.