



Besam UniSlide Installation, Adjustment and Troubleshooting Manual for Concealed and Surface Applied Packages



Complies with ANSI/BHMA A156.10-1999 standard for Power Operated Pedestrian Doors. UL 325 Listed



IAA007AUS

Issue 08-03-2004

© Copyright 2004 Besam Automated Entrance Systems, Inc. May not be reprinted without permission



CAUTION

AAE407

Improperly adjusted doors can cause injury and equipment damage.

Inspect door operation daily using safety checklist in Owner's Manual.

Have door adjusted as described in Owner's Manual.

Safety devices must be in place and operational.

Have door inspected at least once a year by an AAADM inspector, and always after any adjustment or repair.

In the following manual, the word:

Caution means that injury or property damage can result from failure to follow instructions;

Note indicates important steps to be followed or important differences in equipment.

At each revision all revised pages will get a new updated issue number (month-day-year).

The first page will always have the same issue number as the revised pages.

Changes will be marked with a vertical line in the margin.

The table below shows the latest issue numbers.

Page	Issue No.	Page	Issue No.	Page	Issue No.
01	10-15-2001	22	10-15-2001	43	10-15-2001
02	06-29-2001	23	10-15-2001	44	10-15-2001
03	10-15-2001	24	10-15-2001	45	10-15-2001
04	10-15-2001	25	06-29-2001	46	10-15-2001
05	10-15-2001	26	10-15-2001	47	06-29-2001
06	06-29-2001	27	10-15-2001	48	10-15-2001
07	06-29-2001	28	10-15-2001	49	06-29-2001
08	10-15-2001	29	10-15-2001	50	10-15-2001
09	10-15-2001	30	06-29-2001	51	06-29-2001
10	10-15-2001	31	10-15-2001	52	10-15-2001
11	10-15-2001	32	10-15-2001	53	10-15-2001
12	10-15-2001	33	10-15-2001	54	10-15-2001
13	10-15-2001	34	06-29-2001	55	10-15-2001
14	06-29-2001	35	06-29-2001	56	06-29-2001
15	06-29-2001	36	10-15-2001	57	10-15-2001
16	10-15-2001	37	10-15-2001	58	10-15-2001
17	10-15-2001	38	10-15-2001	59	06-29-2001
18	10-15-2001	39	10-15-2001	60	06-29-2001
19	10-15-2001	40	10-15-2001	61	06-29-2001
20	10-15-2001	41	10-15-2001	62	06-29-2001
21	10-15-2001	42	10-15-2001		

Caution	2
Revision	3
Content	4-5
Important information	6
Introduction	7
Technical specifications	8
Design and function description	9
Models	10
Part Identification & Options	11
Active Leaf Panic Break Out system	12
Side Light, fixed	13
Side Light, break out	13
Bottom Guide System	14
Various Options	15
Space required	16
Pre Installation Questions	17
Installation Overview	18
Installation Examples	19
Concealed	19
Surface Applied	20
Installation Requirements	21
Site Inspection	22
Mechanical Installation	23-38
Checking - Marking out - Fastening	23
Levelling Header and Jambs	23
Fitting the floor guide track	24-25
Fixed Sidelite Installation Procedure	26
Full Beak-out Sidelite Installation Procedure	27
Setting the active leaf roller guide pivot (Fixed Sidelite)	28
Hanging the active door leaves	29
Setting the active leaf pin guide pivot (Full Break Out)	30
Height adjustment	31
Attachment of tooth belt fittings	32
Adjustment of the leading edge (to avoid finger traps)	33
Checking and adjusting the belt tension	34
Interlocks for FBO units	35
Adjusting ball catches	36
Manual lock system adjustment and re-keying	37
Installing/Removing the cover	38

Contents cont.

Transom	39-45
General preparation	40
Frame preparation	40
Flush glaze system	41
Setting the frame	42
UniSlide Transom system: 1/4" Flush glaze	43
UniSlide Transom system: 5/8" Thermopane glaze	44
UniSlide Transom system: 1" Thermopane glaze	45
Electrical connections	46
Installation	46
Main connection	46
Control unit	47
Contacts for connection of standard units	47
Terminal block for connection of auxiliary units	47
Function selector, FS	48
Potentiometers and learn button	48
Connection of program selectors	49
Connection of activation units	50
Extension units	51-53
Fitting the extension units	51
Extension unit, EXU-1	52
Extension unit, EXU-3	52
Convenience battery, UPS	53
Start-Up	54
Program selectors and functions	55
Sign Placement	56
Troubleshooting	57-58
ANSI / BHMA A156.10 - 1999	59
Maintenance/Service	60
Planned Maintenance Checklist	61
Door Handing and Layout	62

Radio and television reception

This equipment generates and uses radio frequency energy and if not installed and used properly, that is, in strict accordance with the manufacturer's instructions, may cause interference to radio and television reception. It has been designed to comply with the emission limits in accordance with EN 50081-1 (US market FCC Part 15) which are designed to provide reasonable protection against such interference in a residential installation. However, there is no guarantee that interference will not occur in a particular installation. If this equipment does cause interference to radio or television reception, which can be determined by turning the equipment off and on, the user is encouraged to try to correct the interference by one or more of the following measures:

Re-orient the receiving antenna.

Relocate the receiver with respect to the equipment.

Move the receiver away from the equipment.

Plug the receiver into a different outlet so that equipment and receiver are on different branch circuits.

If necessary, the user should consult the dealer or an experienced radio/television technician for additional suggestions.

Note!

Instructions, design, specifications and illustrations which are contained in this manual are not binding. Rights reserved for changes without previous notice.

Environment

This operator may be equipped with batteries containing materials which are hazardous to the environment. Remove the batteries from the operator before it is scrapped. The batteries must be disposed of safely.

This manual contains the necessary details and instructions for the installation, maintenance and service of the sliding door operator, Besam UniSlide.

The Besam UniSlide is designed for an overhead concealed installation between two vertical jambs or surface applied. The header holds the drive and control units and supports the sliding doors, sidelites and transom above the operator, if required.

A Besam UniSlide operator ensures all-around safety. It can be combined with the full range of Besam safety units, such as UniScan presence and motion detector. It is easy to install for both new construction and retrofit application and can be adapted to a wide range of concealed or surface applied installations.

Technical specifications

Mains power supply	100 V AC -15% to 240 V AC +10% 50/60 Hz, 3 Amp
	Note! Switch with clearly marked off-position, having a contact separation of at least 3 mm (1/8") in all poles, must be incorporated in the mains wiring.
Power consumption	max. 250 W
Auxiliary voltage	24 V DC, 0.64 Amp (640 mA)
Control unit fuse	6.3 Amp (6,3 AT)
Recommended max. door weight	<u>Bi-parting</u> UniSlide-2 100 kg/leaf (220 lb./leaf) <u>Single Slide</u> UniSlide-R/L 200 kg (440 lb.)
Clear opening	<u>Bi-parting</u> UniSlide-2: 900 – 2400 mm (35.5" – 94.5") [optional up to 2800 mm (110")] <u>Single Slide</u> UniSlide-R/L: 900 – 2000 mm (35.5" – 78.5") [optional up to 2800 mm (110")]
*Opening and closing speed	<u>Bi-parting</u> (UniSlide -2) variable up to approx. 1.4 m/s (4.5 ft/sec.)
*Hold open time	0-60 seconds
Ambient temperature	-20°C to +50°C (-4°F to 122°F) [-35°C to +50°C (-31°F to 122°F) with silicone belt]
Relative humidity (non-condensing)	5%-85%

To be installed internally or with suitable weather protection externally.

* To be adjusted to comply with ANSI/BHMA A156.10.
Note that local codes may vary.

Note!

The glazing material of all doors shall comply with the requirements in the American National Standard Performance Specification and Methods of Test for Safety Glazing Material Used in Buildings, Z97.1-1975.

Design

The sliding door operator Besam UniSlide works electro-mechanically. The motor, control unit, transmission – and optional emergency unit and electromechanical locking device – are all assembled in a support beam with integrated cover. The motor and gear box transmit movement to the door leaves by means of a tooth belt. The door leaf is attached to a door adapter/carriage wheel fitting and hangs on a sliding track. The guiding at the bottom is carried out by means of floor guides. (Full Break Out) or Side Panel Guides (Fixed Sidelights)

Function

Opening

When an opening impulse is received by the control unit the motor starts and transmits movement to the door leaves which move to open position.

Closing

The closing starts when the “opening impulse” and the “hold open time” has run out.

Safety functions integrated in the operator

To permit safe passage between closing doors, the doors immediately reverse to open position if an obstruction is detected, then resume their interrupted movement at low speed to check whether the obstruction has disappeared or not. If an obstruction is detected between opening doors and surrounding walls or interior fittings, the doors immediately stop and then close after a time delay.

Microprocessor for precise control

The microprocessor has an integral self-monitoring device which detects most interference or faulty signals in door operation. If an input signal does not correspond to the preprogramming, the microprocessor automatically takes necessary measures to ensure a safe operation.

Emergency escape

The Besam UniSlide can be combined with an emergency unit that automatically opens or closes¹ the doors in the event of a power failure and can also be interfaced with the fire alarm or smoke detector.

Safety is further reinforced by incorporating a panic fitting. This enables the doors and/or sidelites to be swung outwards in an emergency situation by applying light pressure.

¹ Electronic emergency unit only

Safety sensors

Safety sensors must be installed per ANSI 156.10 on Pedestrian Applications.

Besam provides several layouts for the UniSlide sliding door system. Operators can be bi-parting or single slide (left or right handed), and sidelites may be installed fixed to the interior or hinged to break out in emergency situations. (See page 62 for illustrations of various layouts.)

All UniSlide systems are ready for installation when delivered. The sidelites and active leaves are fully prepared and all hardware is installed. Operators are supplied with all mounting hardware, and rivnuts have been installed in the side jambs.

Before installing the UniSlide system, check to see that you have been supplied the correct equipment and that all necessary tools and hardware are at hand (see page 21). Also, check the installation site for any factors that might interfere with proper installation (see page 22).

Naming conventions

Explanation

UniSlide OC S-R FSL	length height finish	overhead concealed,	standard,	single slide right hand, fixed sidelite
UniSlide OC S-R FBO	length height finish	overhead concealed,	standard,	single slide right hand, full break out
UniSlide OC S-L FSL	length height finish	overhead concealed,	standard,	single slide left hand, fixed sidelite
UniSlide OC S-L FBO	length height finish	overhead concealed,	standard,	single slide left hand, full break out
UniSlide OC S-B FSL	length height finish	overhead concealed,	standard,	bi-part, fixed sidelite
UniSlide OC S-B FBO	length height finish	overhead concealed,	standard,	bi-part, full break out

Notes!

Length and height is specified in inches and fractions of an inch after the dash - based on the following list.
 0/8" = -- 00; 1/8" = -- 18; 1/4" = -- 14; 3/8" = -- 38; 1/2" = -- 12; 5/8" = -- 58; 3/4" = -- 75; 7/8" = -- 78;

Finish is specified by the following list

CL = Clear Anodize; DB = Dark Bronze Anodize SP = Special (May consist of Wet Process, Powder Coat or Cladding)

Bi-Part FBO Model No.	COW	FW	DW
UniSlide OC S-B FBO 96.0	36"	96"	24-3/8"
UniSlide OC S-B FBO 120.0	48"	120"	30-3/8"
UniSlide OC S-B FBO 144.0	60"	144"	36-3/8"
UniSlide OC S-B FBO 168.0	72"	168"	42-3/8"
Key:	(FW/2) - 12"	ROW - 1/2"	(FW/4)+3/8"

Single Slide FBO Model No.	COW	FW	DW
UniSlide OC S-R FBO 84.0	35-1/4"	84"	41-1/2"
UniSlide OC S-L FBO 84.0			
UniSlide OC S-R FBO 96.0	41-1/4"	96"	47-1/2"
UniSlide OC S-L FBO 96.0			
UniSlide OC S-R FBO 102.0	44-1/4"	102"	50-1/2"
UniSlide OC S-L FBO 102.0			
Key:	(FW/2)-6-3/4"	ROW - 1/2"	(FW/2)-1/2"

Note: Charts are for narrow stile doors with 1/4" glazing. Wider stiles or thicker glazing will reduce the COW dimension accordingly.

FW = Frame width COW = Clear opening width/Net opening
 SW = Sidelite width ROW = Rough opening width
 DW = Door leaf width

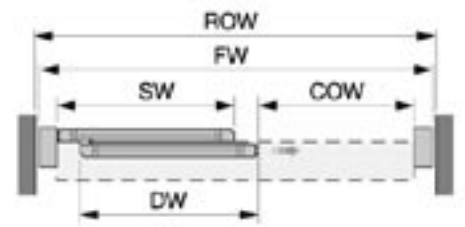
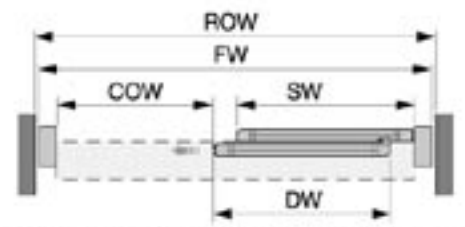
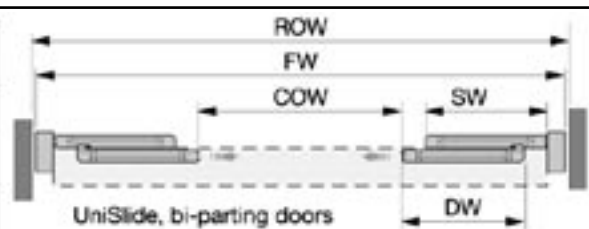

AAE900

Part Identification & Options

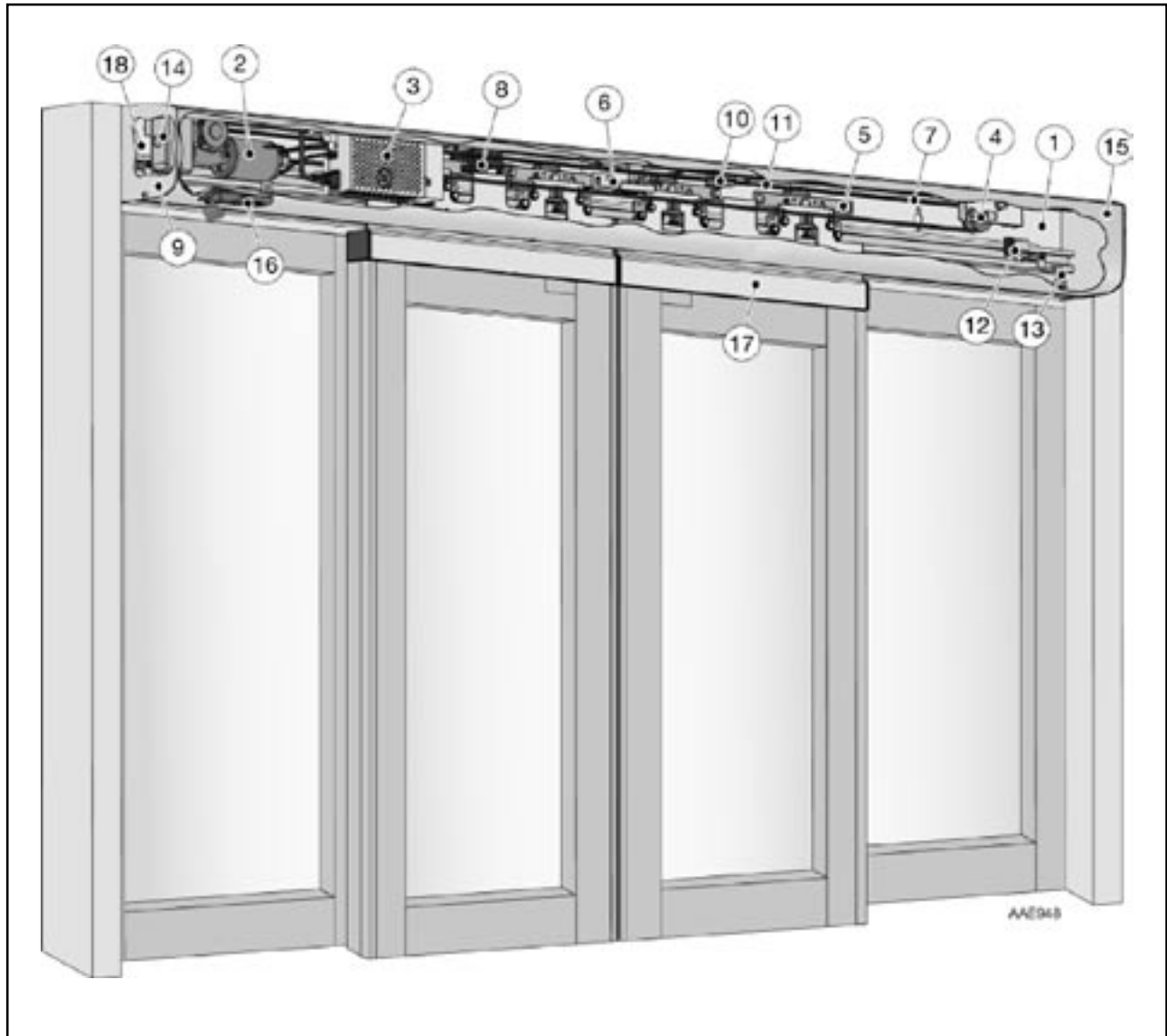

- | | |
|---------------------------------------|------------------------|
| 1. Support beam | 11. Belt joining clamp |
| 2. Drive unit | 12. Door stop |
| 3. Control unit | 13. Cover lock |
| 4. Tension wheel | 14. Connection box |
| 5. Carriage wheel bracket | 15. Cover |
| 6. Locking device (option) | 16. Program selector |
| 7. Tooth belt | 17. Door carrier |
| 8. Electronic emergency unit (option) | 18. Cable inlet |
| 9. End plate | |
| 10. Tooth belt fitting | |

Active Leaf Panic Break Out System

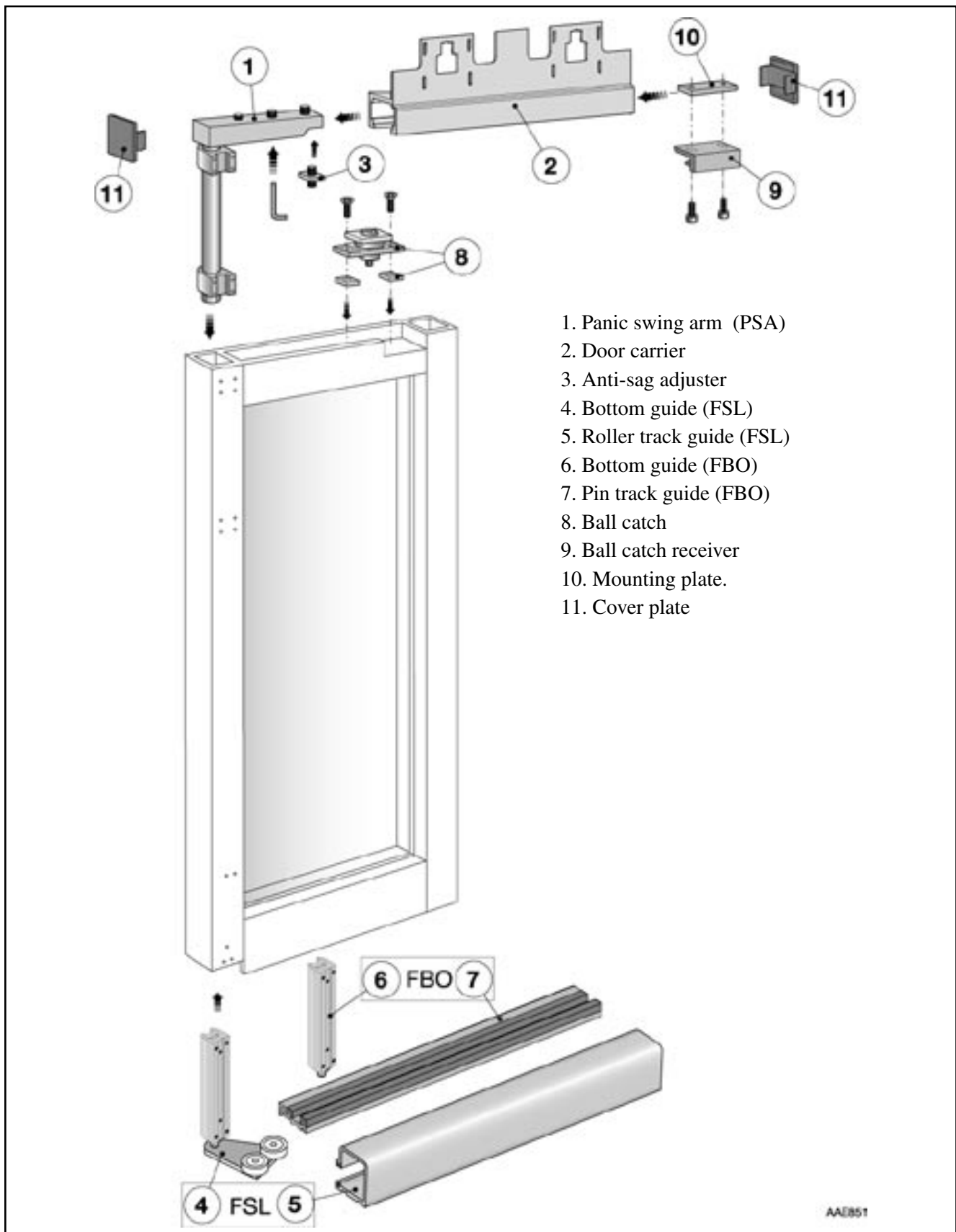

Sidelight, Fixed

Sidelight, Break Out

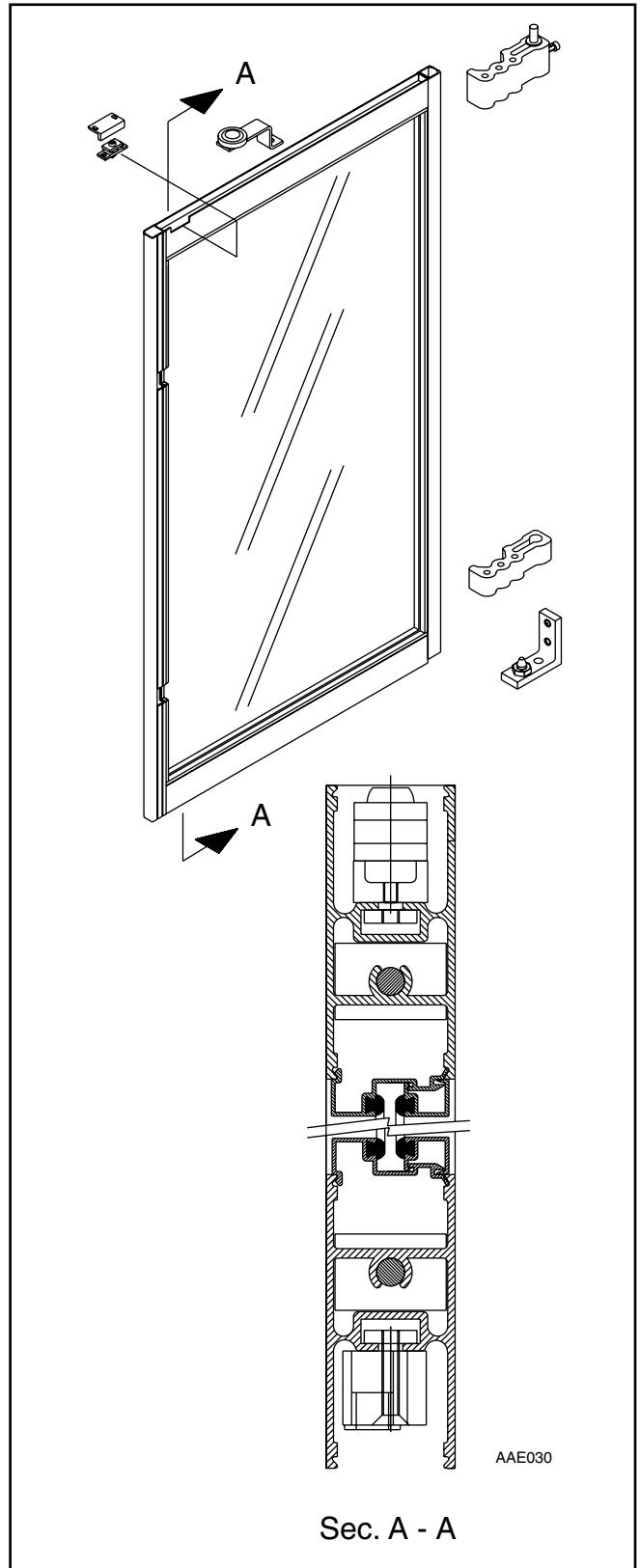
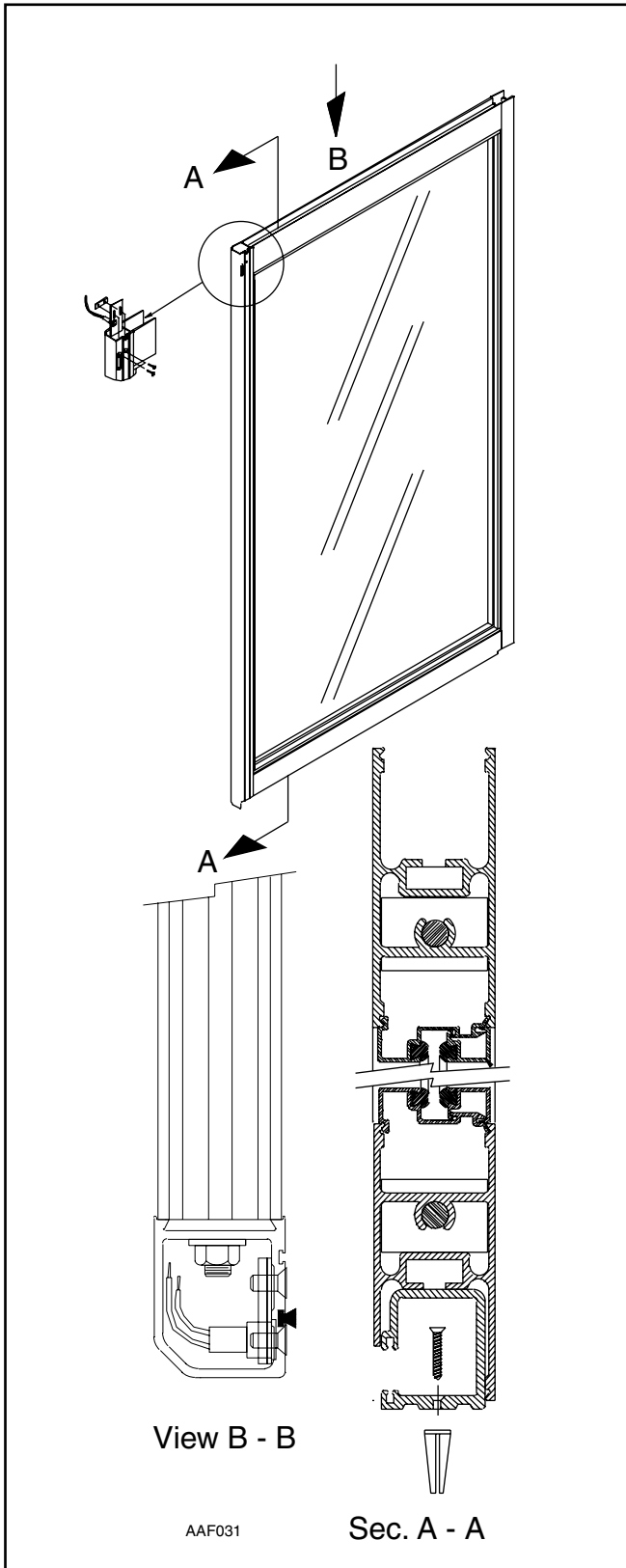

Bottom Guide Systems

Three basic guide systems are available:

- The standard pin guide (FBO, or Full Break Out) with guide track.
- The roller guide (FSL, or Fixed sidelite) with fixed sidelite track.
- The non-panic floor guide.

The FBO pin guide has several options for guide tracks, including:

- Recessed track (flush with floor level)
- Recessed threshold, and surface threshold.

See pages 24-25, 28 and 30 for guide installation.

Pin Guide
P/N: 50-15-390

Roller Guide
P/N: 50-15-147

Non-Panic Floor Guide
P/N: 50-15-015

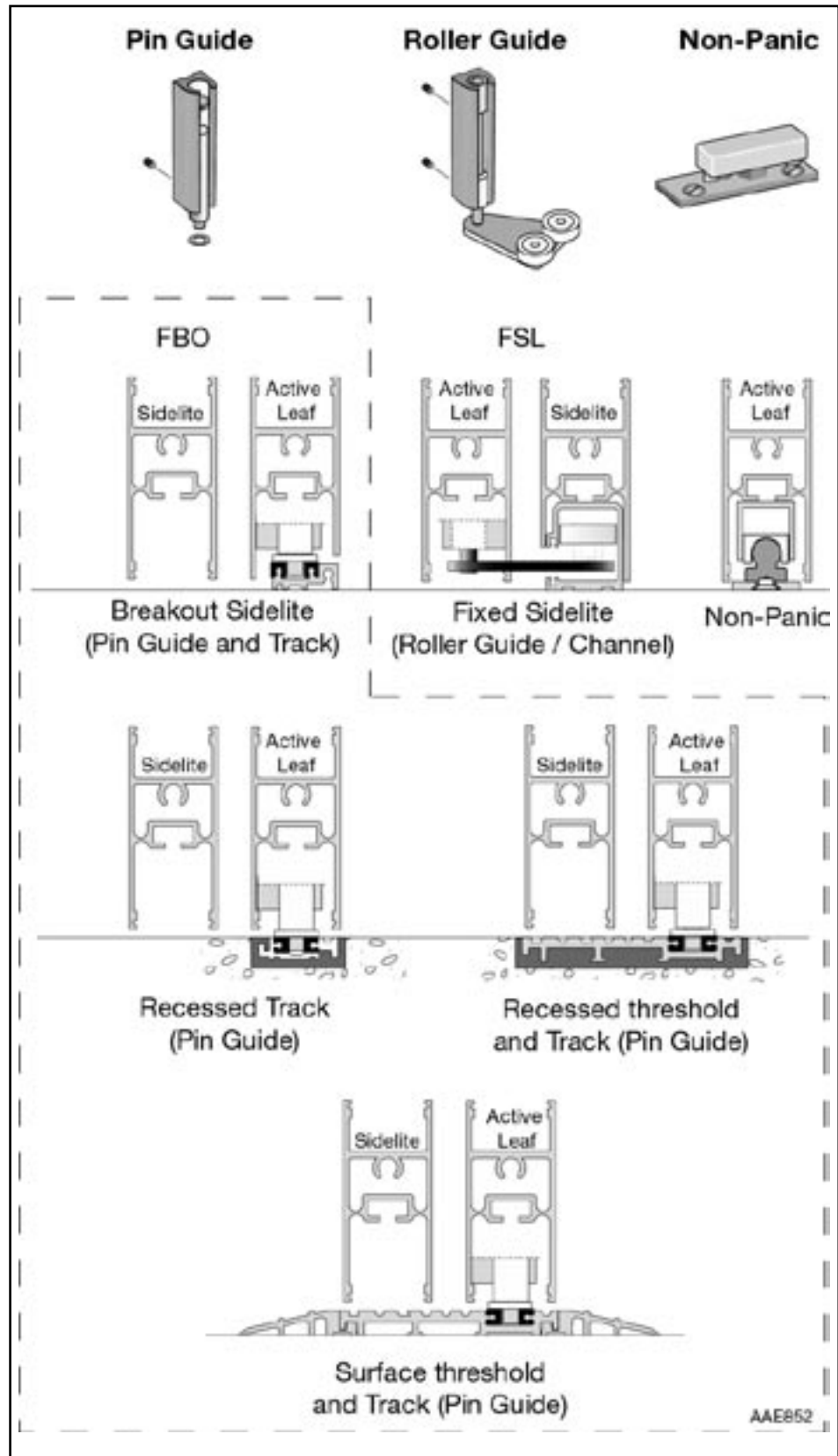

Various Options

Push button PB
 Art. No. 600134
 See installation drawing 656005



Program selector PS-5R
 Always integrated in the cover or plank trim (std)
 Part number 600135



Knob part number 1000474

Electromechanical lock LD
Fail secure (Locked without power)
 Art. No. 550494
 See installation drawing 656007

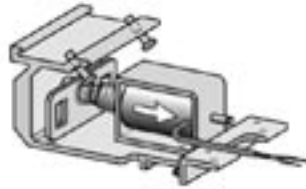

Program selector PS-5M
 Art. No. 600139
Program selector PSMB-5
(box only) Art. No. 600093
 See installation drawing 600037



Electromechanical lock LDP
Fail safe (Locked with power)
 Art. No. 550516
 See installation drawing 656007

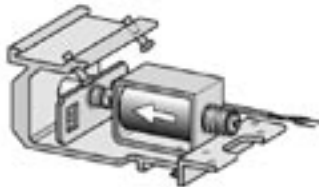

Extension Unit EXU-3
 Art. No. 655953

Convenience battery UPS
 Art. No. 550473



AAE987

Space required

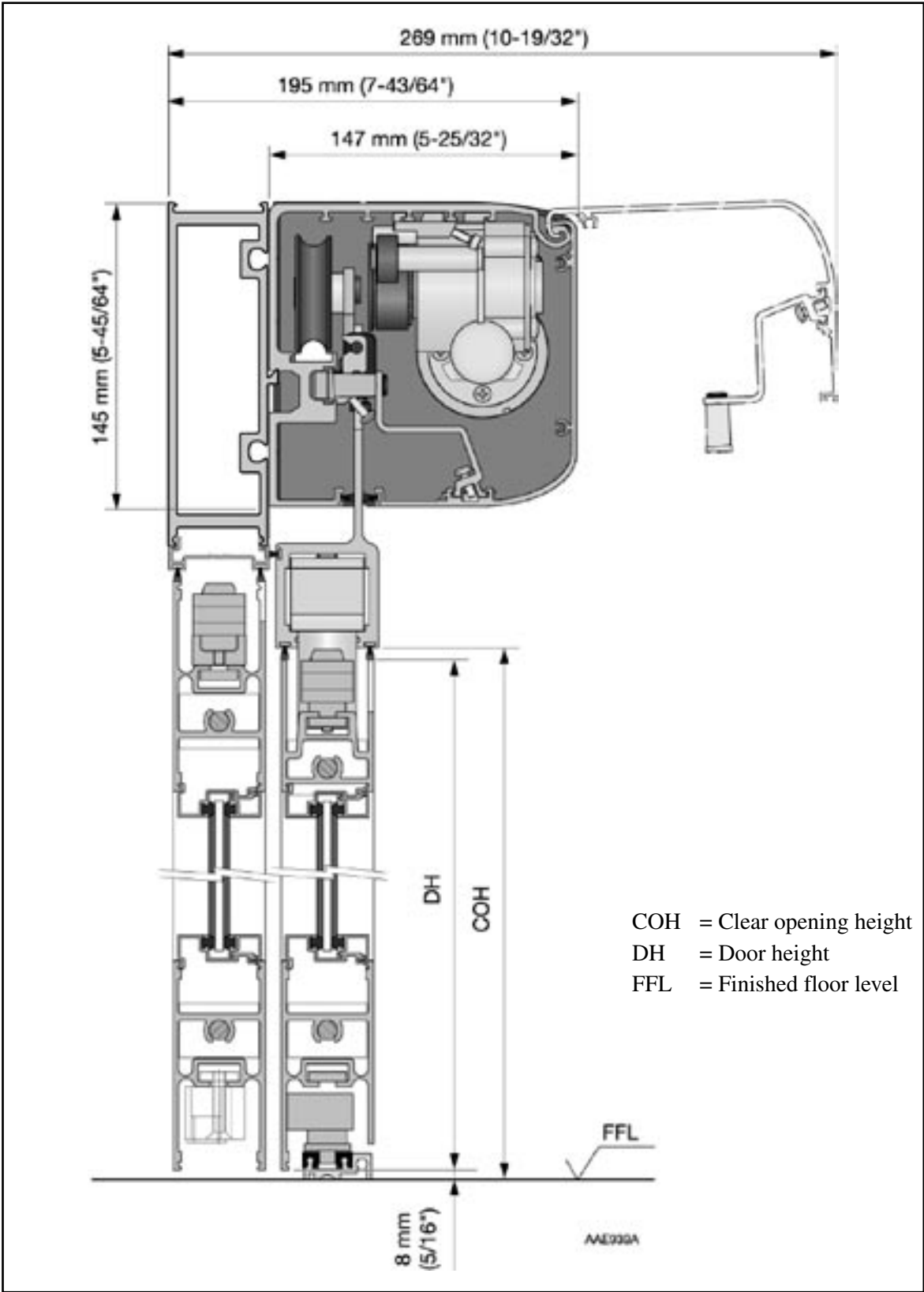

This section will help you to determine the right configuration and preparation for your doors.

- A. Is this a Surface Applied or Concealed Package?
- B. Is this installation a bi-parting or single-slide?
- C. If a single slide, what is the handing, left or right? (See page 62).
- D. Does this installation include a transom? (See pages 39-45).
- E. Where will power and signal wires enter the operator housing? (Back, End cover, Transom tube.)
- F. Is this a Full Break out (FBO), Fixed Sidelite (FSL), or Non Panic installation?

General Tips / Safety Concerns

Caution!

Make sure that the power is off before installing, including battery backup if so equipped.

Caution!

Make sure that the wall is properly reinforced at the installation points. See page 20 for specifications and suggestions.

This is only a summary of the installation process. See the rest of this manual for detailed information.

1. Start by determining the answers to the pre-installation questions on page 17.
2. First install header to jamb tubes if concealed, tilt into place, level and plumb, then secure to rough opening with shims and appropriate fasteners. See page 20 for fastener recommendations.
If surface applied mount operator to rough opening header and level.
3. Full Breakout: mount the pin or threshold guide track.
Fixed Sidelite: mount the roller guide track.
Non-Panic: mount the non-panic floor guide(s).
4. Mount the sidelites.
5. Mount the moving door panels.
6. Adjust all door panels for alignment and smooth manual movement. Adjust all break outs to comply with applicable building codes.
7. Connect tooth belt from drive unit to active door panels.
8. Complete all electrical connections to other operators or optional equipment.
9. Adjust the control unit for optimal and safe performance, in accordance with current ANSI/BHMA A156.10 specifications.
10. Adjust sensor systems for optimal and safe performance in accordance with current ANSI/BHMA A156.10 specifications.
11. Apply safety signage to the door(s).
12. Train facility manager in operation.
13. Explain to the facility manager the daily safety check described in the owner's manual, and leave a copy of the owner's manual with the facility manager.

Concealed

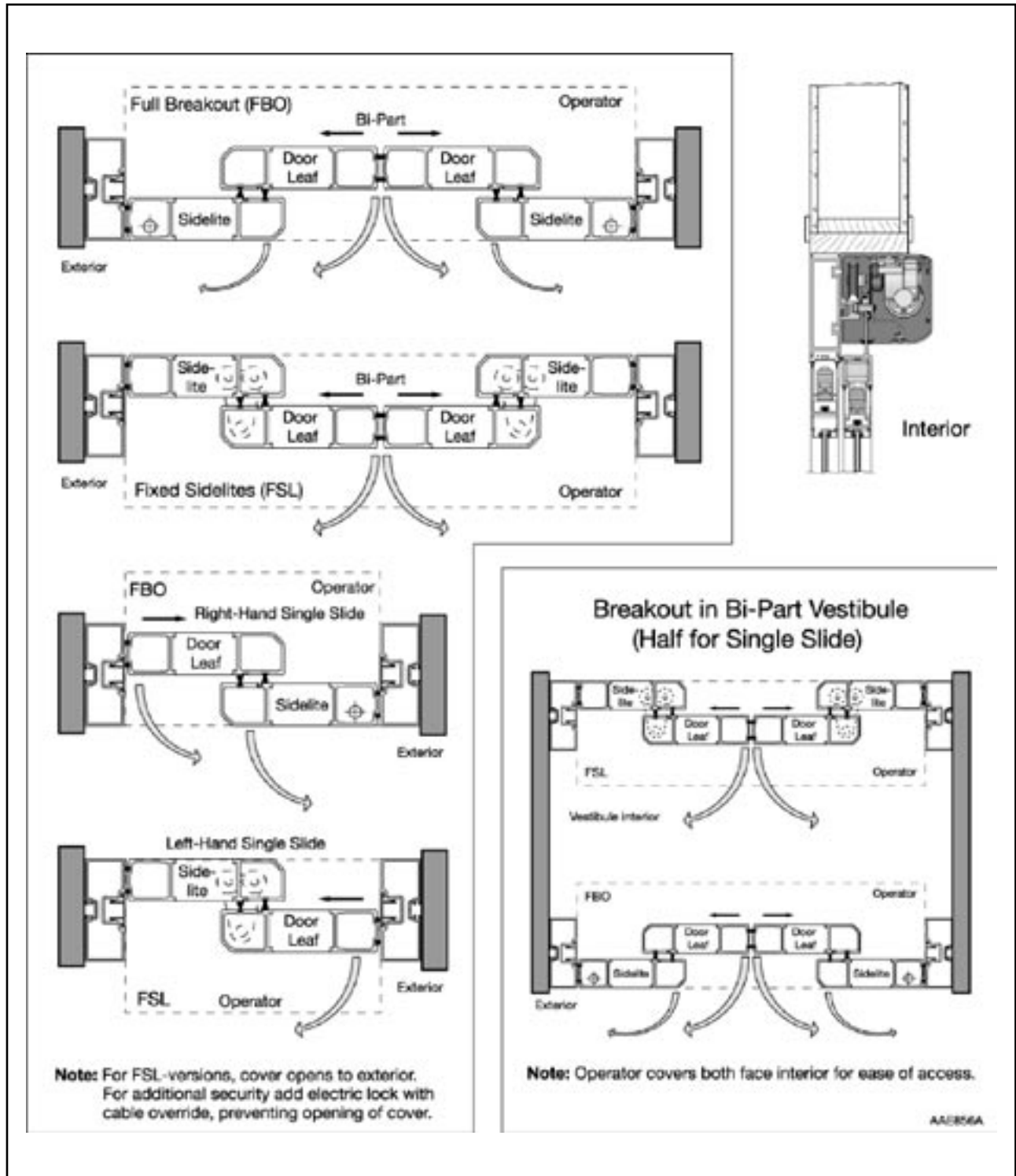

Surface Applied

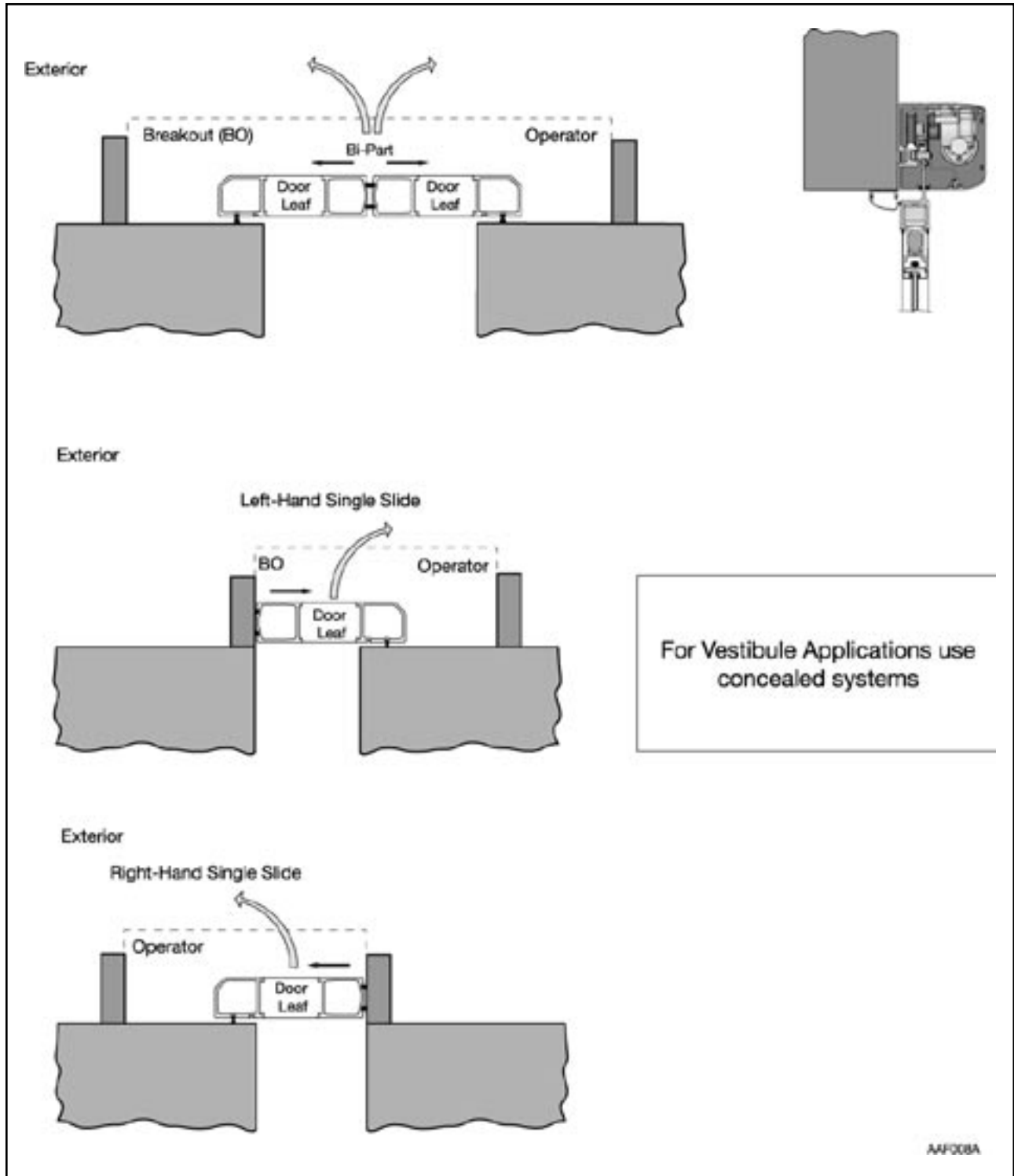

Fastening Requirements

Base door / wall material	Minimum anchor / bolt requirement*
Steel	5 mm (3/16")*
Aluminium	6 mm (1/4")*
Reinforced concrete	min. 50 mm (2") from the underside
Wood	50 mm (2")
Brick wall	Expansion-shell bolt, min. (1/4" x 3 1/2"), min. 50 mm (2") from the underside

* Besam minimum recommended requirements. Building Codes may give different specifications.

* Thinner wall profiles must be reinforced with rivnuts

Test Equipment

Stopwatch
Force gauge (50 lb. force range)
Multimeter

Tools required

Set of metric box and wrenches
Carpenter's level
Tape rule
Power drill and set of drill bits, Unibit, Hammer drill
Metric hex key set 6, 5, 4 mm and 2.5 mm
Screw driver Torx T10, T20
Flat blade screw driver (small/medium/large)
Screw driver for adjustment of potentiometers
#2 Phillips screw driver
Center punch
Wire stripper
Plumb bob
Silicone sealant
Pencil
Additional mounting hardware (not supplied - see fastening requirements above)

The rough opening must be plumb and square and the finished floor must not vary by more than 3/8" from the highest to the lowest point. If necessary, have the floor levelled before attempting to install the sliding door system.

It is important to check the floor level within the path of the doors in break out mode. The doors must not encounter any obstruction when broken out. The grade of the floor in the direction of break out should ideally be 90° or greater, measuring from the highest point of the floor (see below).

For concealed the rough opening width should be 1/2" wider than the overall frame width of the sliding door system, and the rough opening height should be 1/4" higher than the overall frame height. For standard installations, the overall frame height will be 89-3/4", higher with transoms (see pages 39-45).

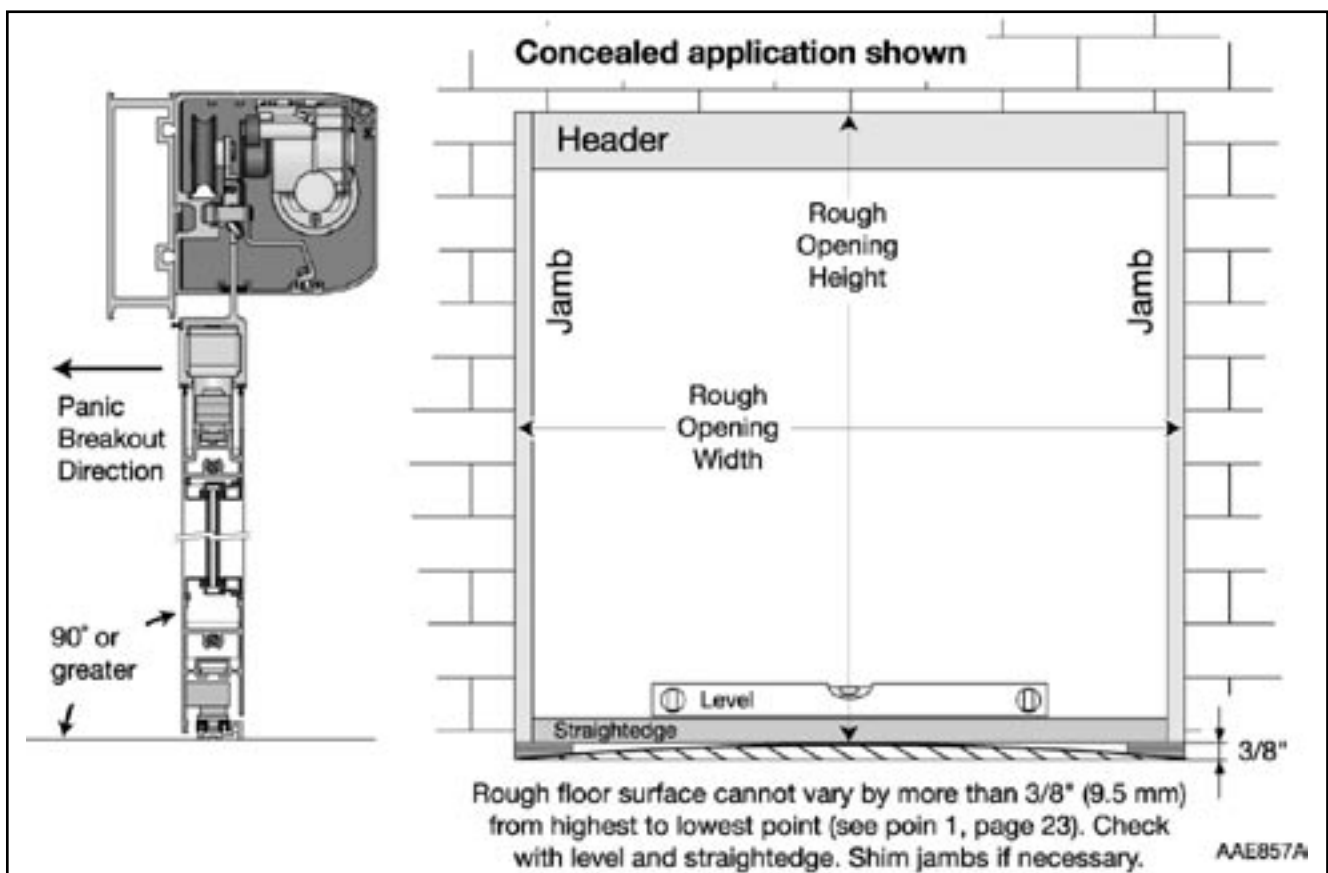

For Surface Applied Standard Applications all narrow frame with 1/4" glass, both Single Slide and Biparts, the overall frame height is 89 3/4".

For Biparts the overall frame width is equal to twice the rough opening plus 9 1/2". [FW= 2(ROW) + 9 1/2"].

For Single Slides the overall frame width is equal to twice the rough opening plus 6 1/4". [FW= 2(ROW) + 6 1/4"]

Concealed Mechanical Installation

Note! Surface applied similar process, however fasten through operator header to building header. Fasten jambs.

Checking – Marking out – Fastening

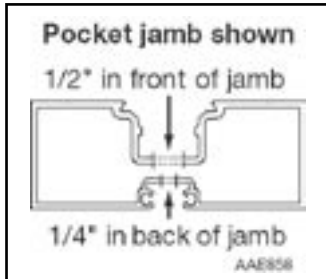

Mark the center of the rough opening width and the center of the header. The center marks will be aligned during installation.

Drill holes at the top, middle and bottom of the jambs for securing to the door opening, adjusting for site conditions that may require the holes to be at a certain height.

Drill 1/2" holes through the face or pocket of the jamb and then drill the back holes to a maximum of 1/4". See illustration.

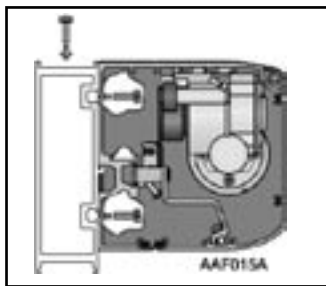

Besam jambs are factory prepared for header installation. Mount jambs to header using three screws per jamb.

Leveling header and jambs

Note! The header and jambs must be square and level to ensure a proper installation!

1. Inspect the rough door opening, measuring from side to side and using a level, to find areas where shims may be needed. Look for high spots in the floor (see page 22); if there is a slight rise in the floor at any point then the bottom of the jambs should be set level with the highest point of the floor, with the header levelled across the opening.
2. Tilt header/jamb assembly up into rough opening in wall, being careful to pull power through access hole in jamb.
3. Start with one jamb. Loosely install the middle fastener, using a level on the outside of the frame to plumb the jamb. Confirm that the header is level across the opening. Repeat for the opposing jamb, loosely installing first the middle fastener, then the top and bottom. Return to the first jamb and install the remaining top and bottom fasteners loosely.
4. Starting with the top screws on both jambs, equally shim behind both jambs, leaving equal gaps and centering the package in the door opening. Tighten the top fasteners. Use your level on the inside of one jamb to determine shim requirements for the middle fastener, then shim and tighten. Repeat for the bottom fastener. Shim and tighten the middle and bottom fasteners on the other jamb in the same way. Check for jamb bowing with a straightedge and correct if present.
5. Recheck the jambs, using a level on the outside and inside of each jamb, and the header. If the header and jambs are truly square, the top jamb to jamb and bottom jamb to jamb measurement should be identical. If necessary, strings can be taped from corner to corner on the outside of the jambs. The strings should cross in the center of the door opening, slightly touching each other. If there is a gap between the strings or the strings are pushing against each other, than the package is twisted and needs adjustment before proceeding

Fitting the floor guide track

Note! It is important that the floor guide track is fixed absolutely level to prevent derailment of the floor guide foot when the door is swung out.

Installation steps for floor mounted guide tracks, recess and surfaced mounted pin guide tracks and G channel tracks for fixed sidelite applications.

1. Inspect the floor for conditions such as high and low spots that can cause the track to twist and rock. High spots (such as small rocks) should be removed; shim the track assembly at the low spots.
2. Using a chalk line, snap a reference line from jamb to jamb on the side where the track is being installed.
3. Using the measurements provided (see page 25), lay the track in place. While standing on the track and keeping it in line with the chalk line, mark the holes to be drilled.
4. Secure the track to the floor with concrete anchors and screws, levelling it with shims from end to end. If possible, a sealant should be used under the track assembly. To check for proper levelling, measure from the top of the track to the bottom of the header, checking for the same result at each fastener.

Note: All screws must be countersunk and fully tightened to avoid interference with pivot travel.

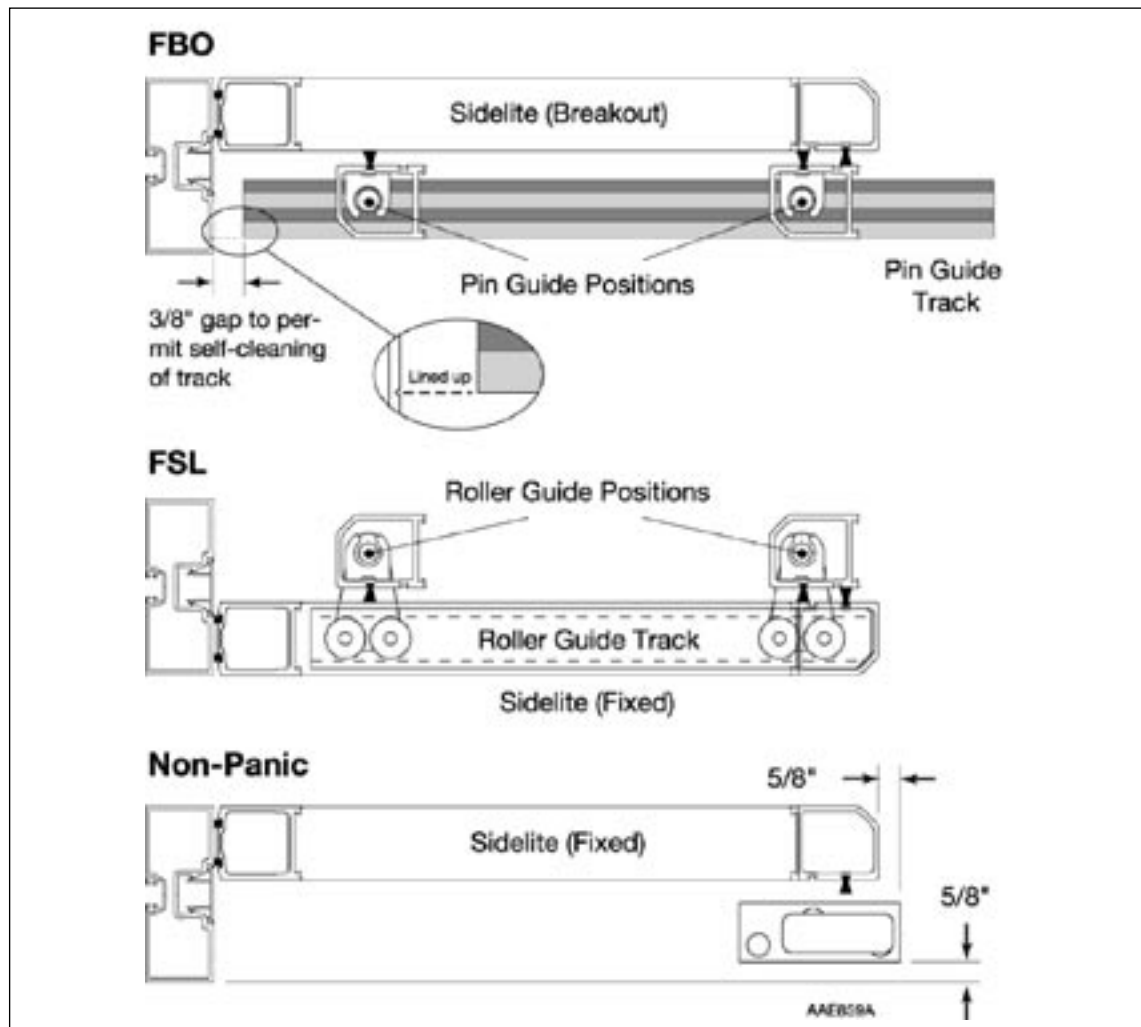

Fitting the floor guide track cont.

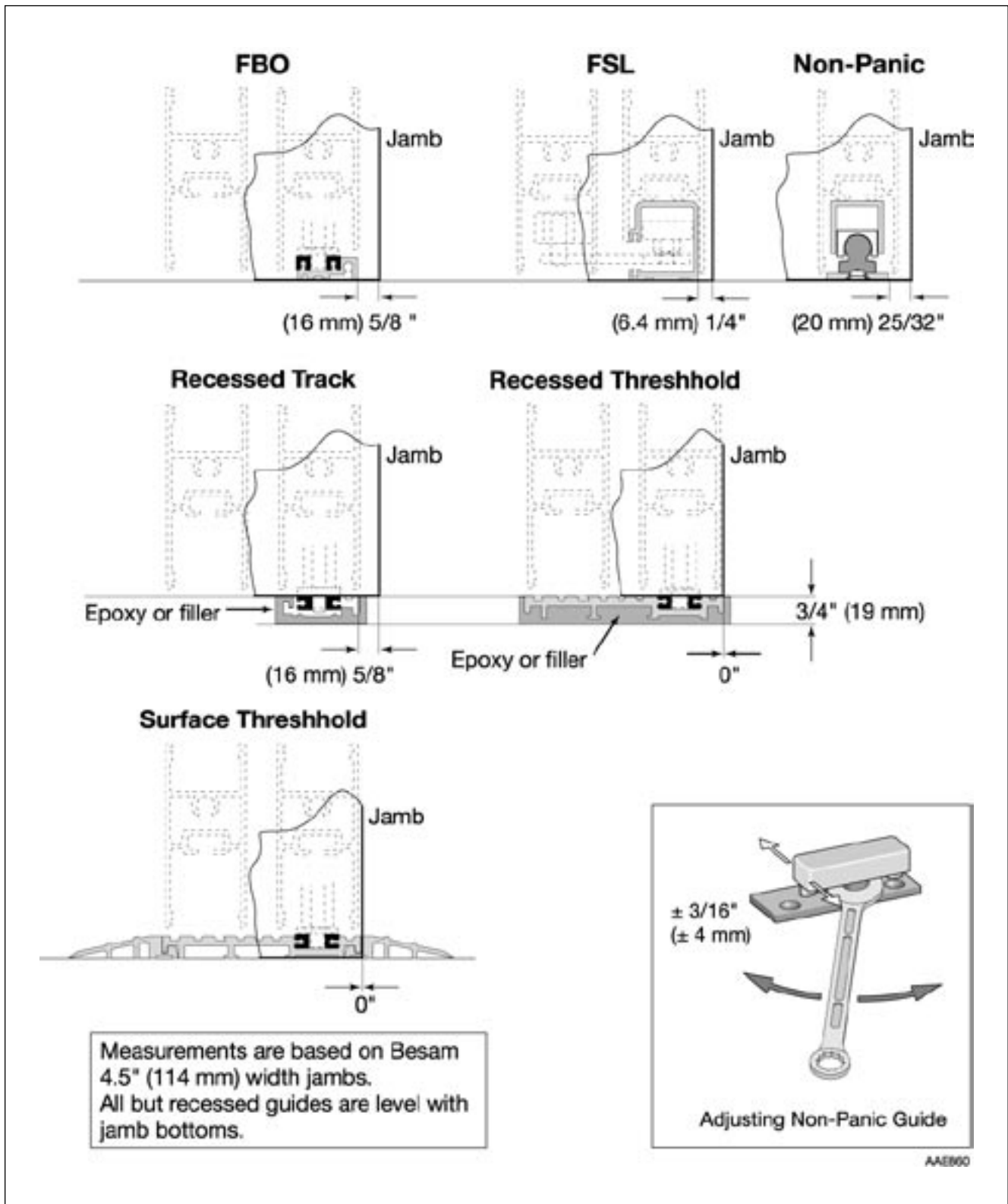

Fixed Sidelite Installation Procedure

Note: Remove any glass stop or packing material from the sidelight before installation.

1. End load the sidelite panel on the roller track guide, and top lower edge extrusion. Slide the panel fully to jamb and fasten with screw through door panel to top lower edge extrusion where active panel hides screw. Run break out pigtailed up through hole in plank to header.
2. For bipart install 2:nd sidelite as above.

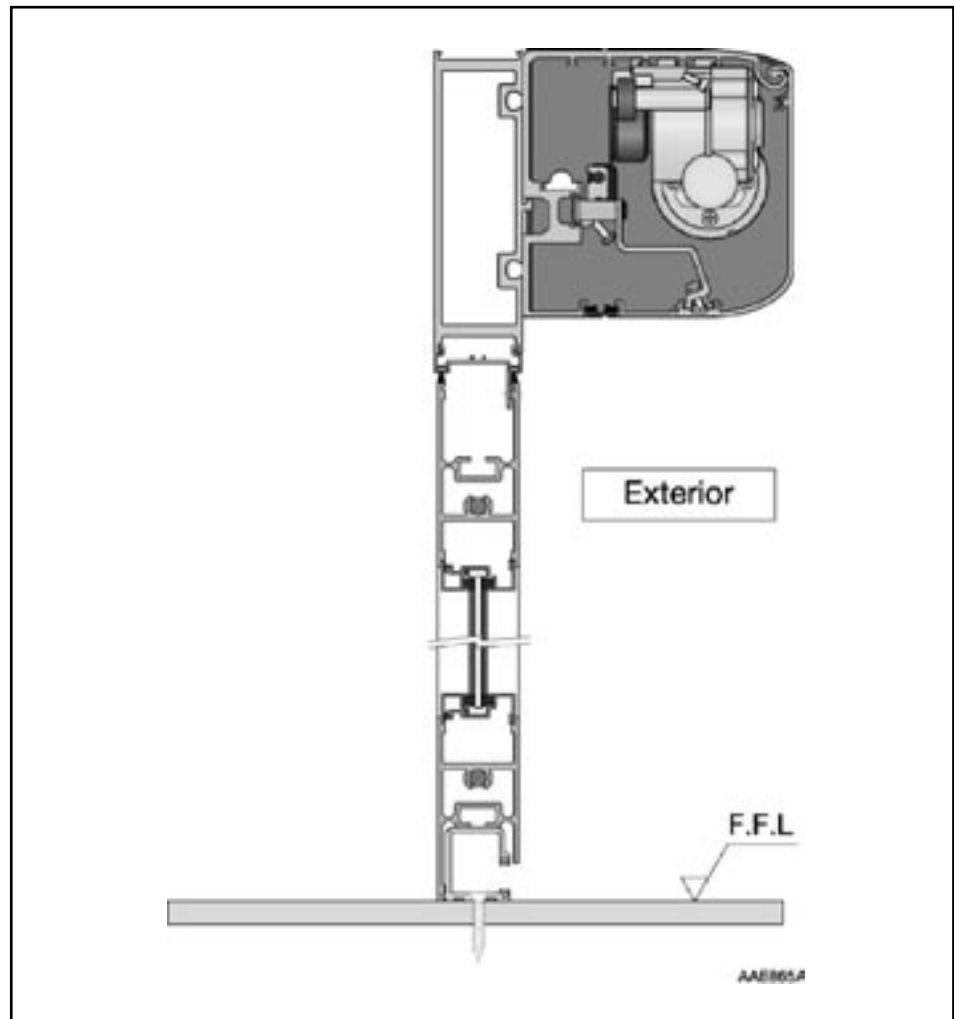

Full Breakout Sidelite Installation Procedure

Note: Remove any glass stop or packing material from the sidelight before installation.

1. Install and level any thresholds (surface or recessed) before installing any of the door panels.
2. Check that jamb mounted bottom pivot is installed and tight.
3. If the pivot base does not rest fully on the floor, support the pivot base with shims.
4. Place the bearing washer on the pivot base. Set the sidelite on the pivot and tilt it into place. There should be no more than 1/8" between the bottom of the header and the top of the sidelite. To adjust, raise or lower the bottom pivot by loosening the set screw at the side of the floor portion of the pivot and turn the shaft clockwise to lower the sidelite and counter clockwise to raise the sidelite; then retighten the set screw. With the sidelite on the bottom pivot, carefully push down the top spring-loaded pivot pin and line it up with its receiving hole in the header portion of the pivot until the shaft pops into place.
5. Check all clearances and make adjustments to the break out latch (See page 36).
6. When all sidelite panels are installed, tighten top pivot security set screw to prevent depressing (carding) pivot pin.

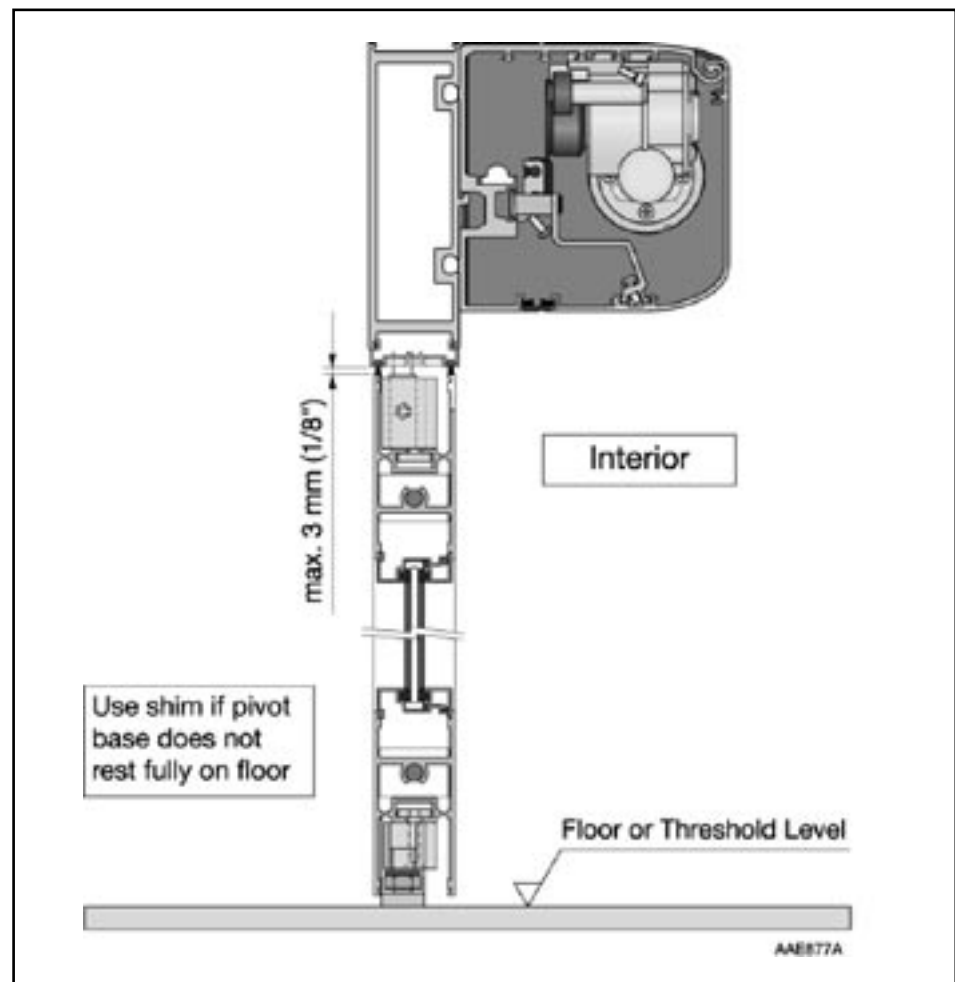

Setting the active leaf roller guide pivot (Fixed Sidelite)

1. Temporarily loosen and remove the door stops. With the door positioned so that the carriage wheels are riding on the plastic track in the header beam, adjust the carriage wheels to a height that will raise the door slightly off the finished floor.
2. Slide the door to the open position until the roller guide lines up with the cut out in the roller track, and insert the bottom guide. (If the roller guide does not line up properly with the cut out, loosen the top set screw, which is accessible when the panel is broken out. Adjust the roller guide until it will slide into the cut out.) Slide the door closed.
3. Proceed to adjust the door as instructed on page 31. With the door(s) adjusted properly, position the roller guide so that it has clearance to slide open and closed without any drag on the top or bottom of the track assembly. Retighten top set screw. Reposition the door stops and adjust accordingly to avoid finger traps at trailing edge (see page 33).
4. The bottom set screw on the roller guide can be adjusted to create drag on the door pivot when the door is broken out.

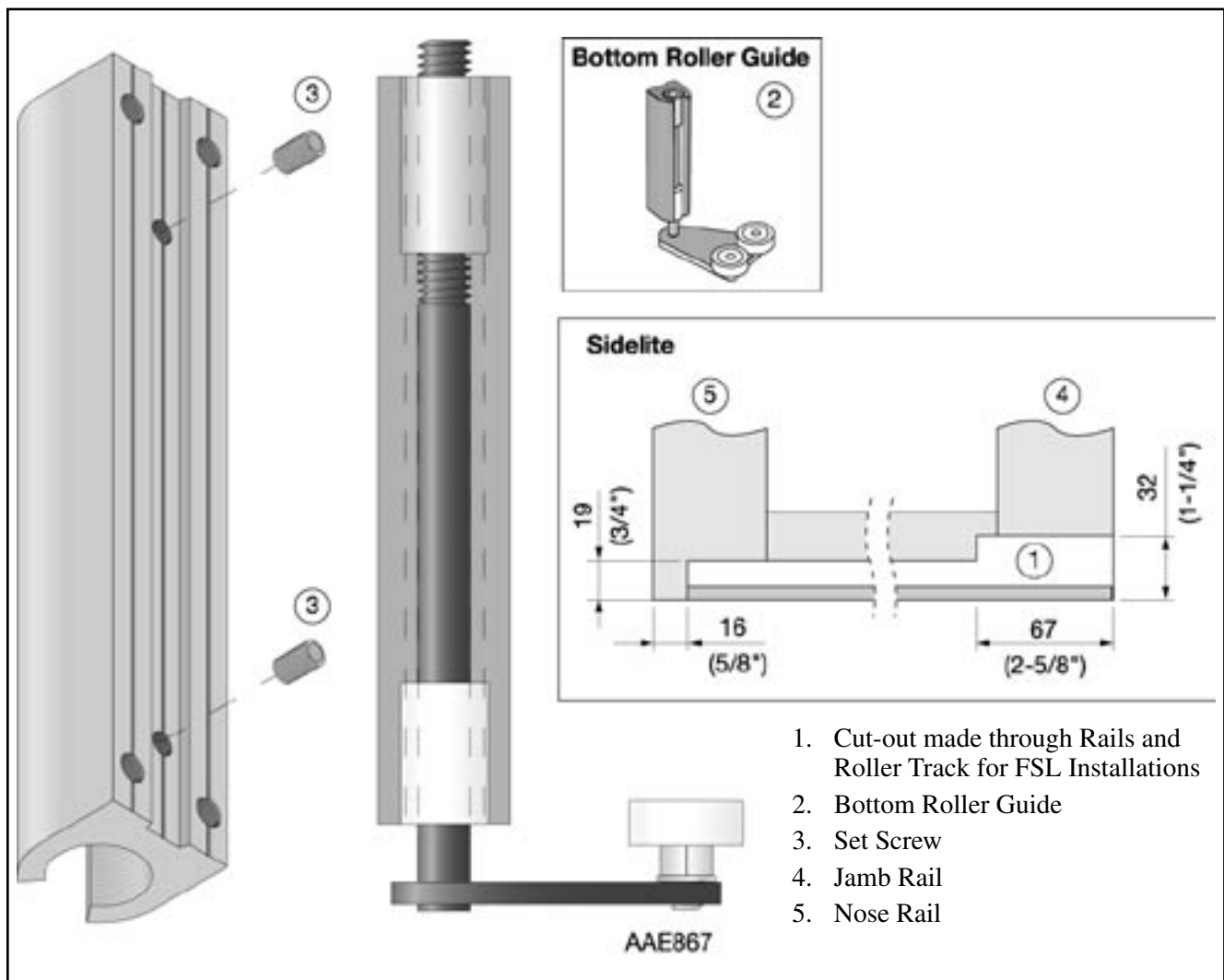

Hanging the active door leaves (Full Break Out)

1. Ensure that the sliding track ① in the support beam is clean.
2. Raise the door leaf and place it **carefully** over the floor guide, ensuring the pin washer is in place.
3. Lean the door leaves against the frame and lift the wheel fittings over the sliding track, lifting the drive belt over the carrier.
4. Loosen the fastening screws ② and let door settle to desired position.
5. Adjust screw ③ until the door leaf is about 6.5 mm (1/4") above the floor. Adjustment range ± 8 mm ($\pm 5/16$ ").
6. Tighten the fastening screws ② and thereafter the adjustment screw ③ to secure the assembly.
7. Place the blocks in the support beam groove and slide them behind the carriage wheel brackets (one in each bracket) and screw the blocks tight.
 - Note! • Belt drive brackets are factory installed to door.
 - Both carriage wheel brackets should be adjusted in the same way.
 - Adjust carriage wheel brackets prior to installing the anti-risers.

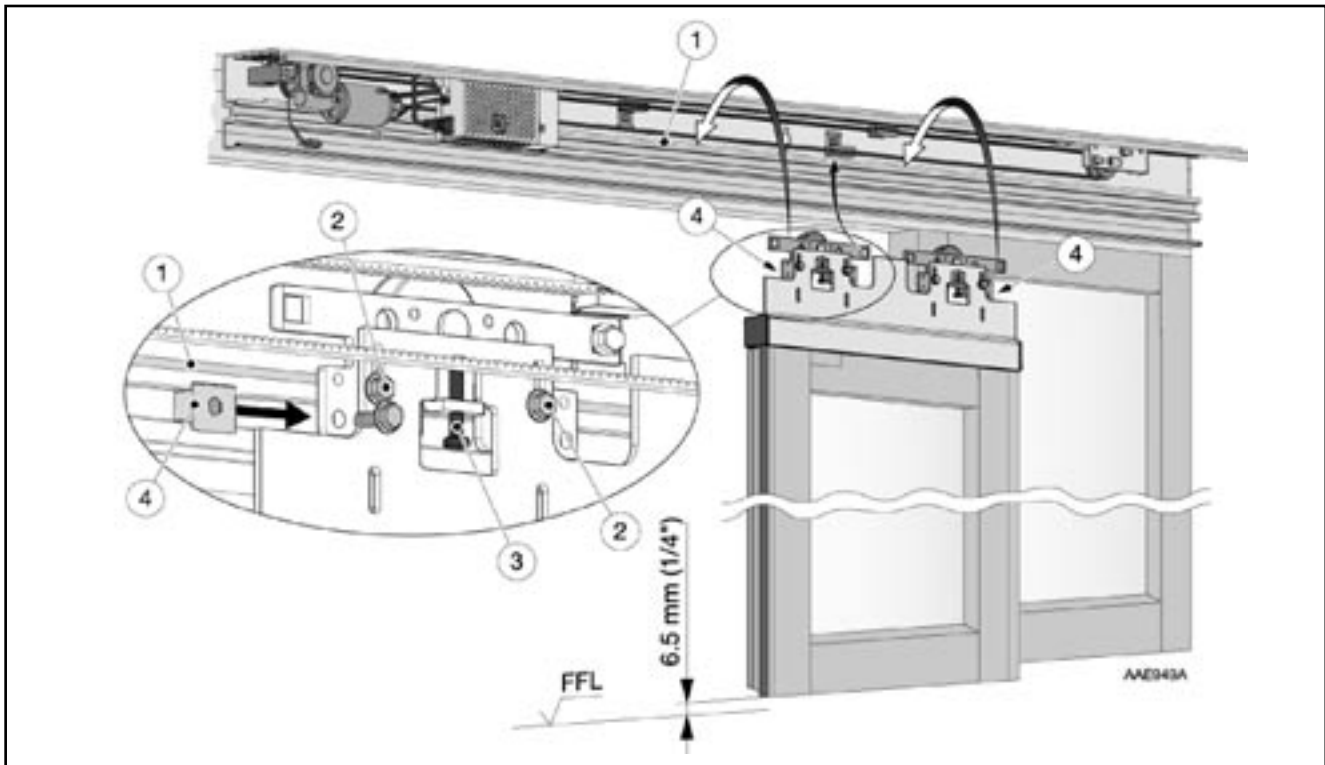

- ① Sliding track
- ② Fastening screw
- ③ Height adjustment screw
- ④ Anti-rise plastic block with fastening screw

Setting the active leaf pin guide pivot (Full Break Out)

Spring tension has been factory adjusted; It may be changed to ensure that pin stays engaged in track. Readjustment requires removing the pivot from the door and adjusting the threaded slug.

For additional security: the pin guide may be locked at its highest point of travel along the floor track, using the set screw.

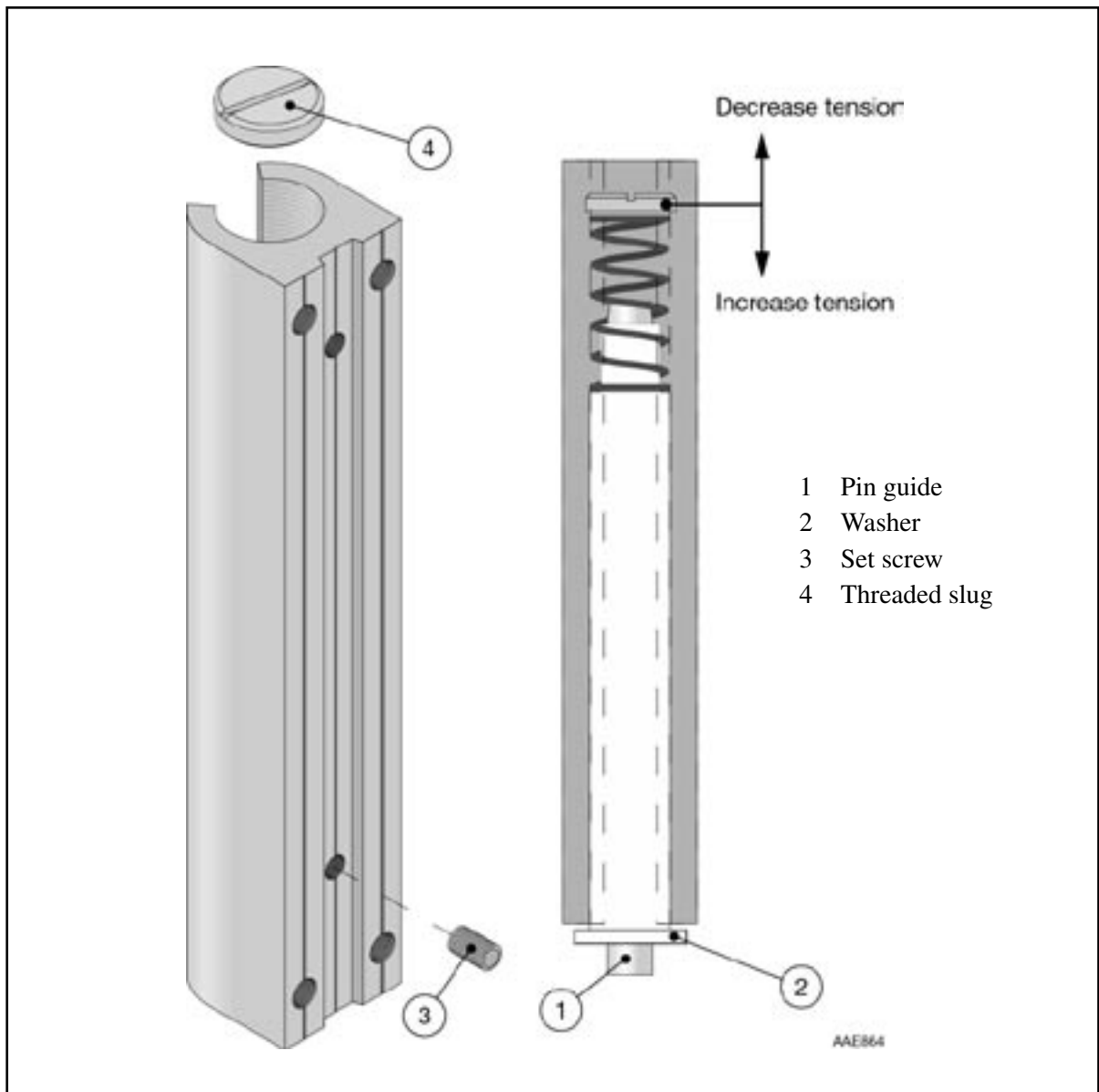

Height adjustment

The height adjustment is to be carried out with the vertical adjustment screw ③ as described on page 29.

1. It is very important that the door leaf hangs vertically after the adjustment and that bi-parting doors are parallel in the closed position (no gap at the top or bottom).
2. The guide pin roller (frame doors) should not touch the upper edge of the door guide track or become easily disengaged.
3. If a weather brush is used on the lower edge of the door leaf, it should only lightly touch the floor.
4. Check that the door leaf is parallel with the fixed panel.

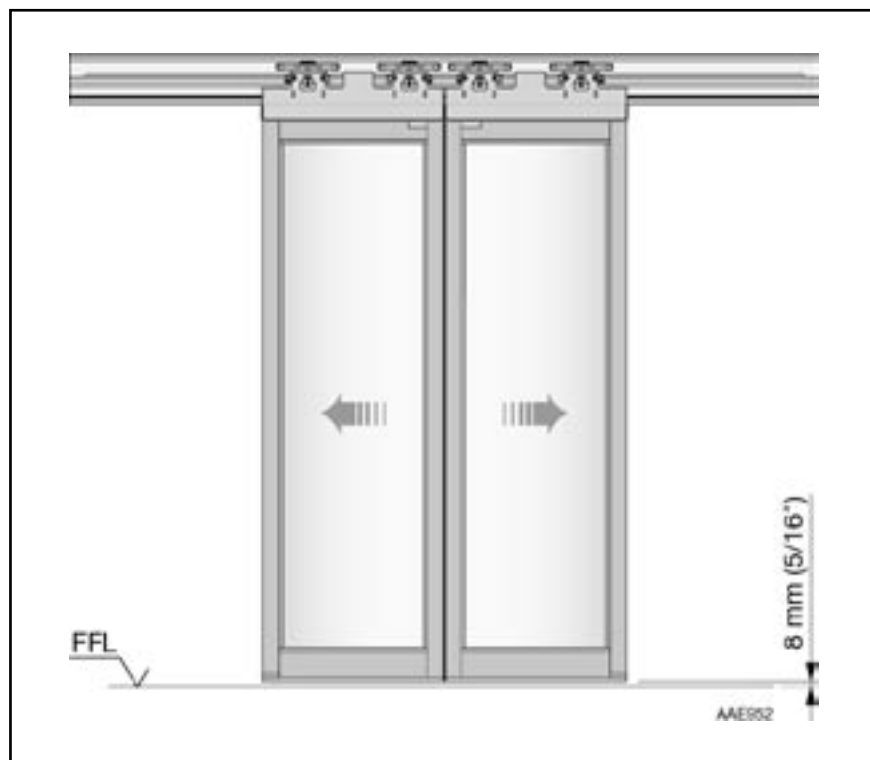

FFL = Finished floor level

Attachment of tooth belt fittings

UniSlides are viewed from the cover side.

Bi-parting operators

1. Put doors in fully closed position.
2. Pull belt joining clamp to left door panel and center it over the (nose) carriage wheel bracket.
3. Insert tooth belt into left door carrier (upper) belt fitting.
4. Insert tooth belt into right door carrier (lower) belt fitting.
5. Check door panels for proper centering.

Single-sliding operators

1. Put door in fully open position.
2. Pull belt joining clamp next to carrier belt fitting (away from nose of door)
3. Insert tooth belt into belt fitting (L.H. upper, R.H. lower)
4. Check door panel for fully closed position.

Note!

Control function selector setting #1—ON—(clockwise). Actual belt movement is counter clockwise.

- ① Tooth belt
- ② Tooth belt fitting, left door leaf
- ③ Carriage wheel bracket
- ④ Tooth belt fitting, right door leaf
- ⑤ Flanged screw
- ⑥ Belt joining clamp

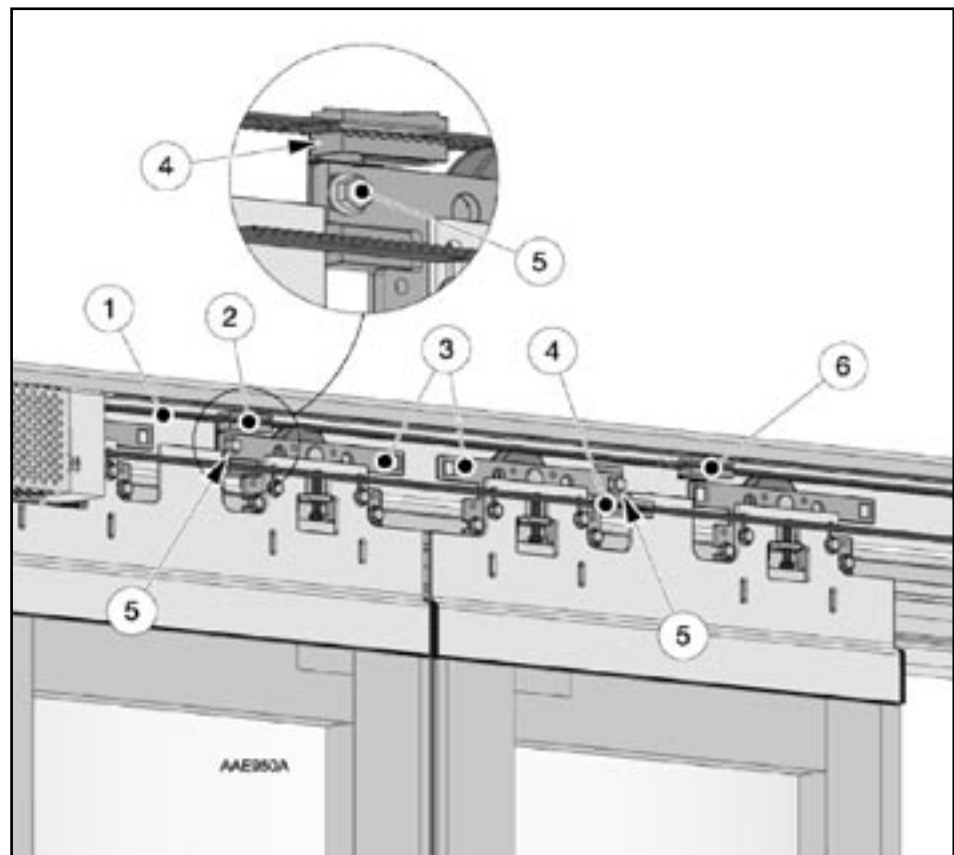

Adjustment of the leading edge (to avoid finger traps)

1. Push the doors by hand to the desired opening.
Note! For frame doors made by others, the lead edge of the door leaf must not pass the vertical rail of the sidelite leaf, but must stop at least 25 mm (1") before to avoid finger traps.
2. Loosen the door stops, move them in against the carriage wheel brackets and tighten firmly.
3. Check that the required opening and finger protection (if any) are achieved.

Frame doors by others

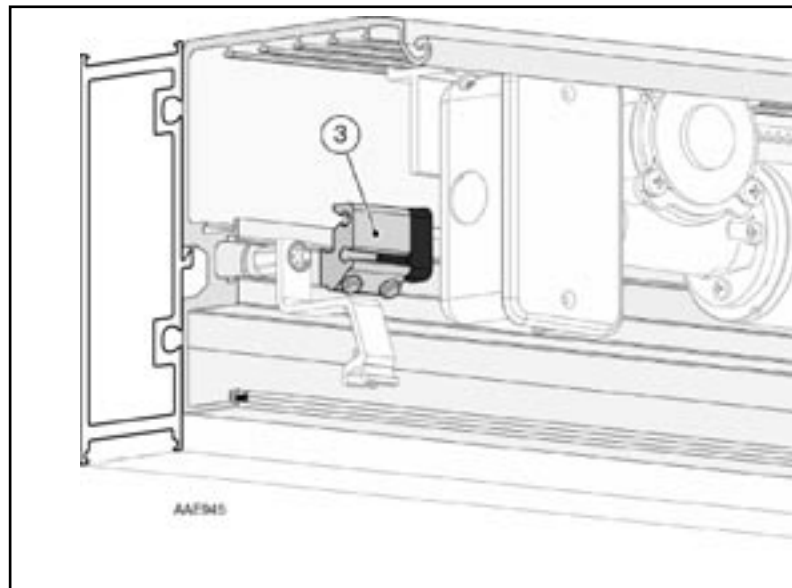
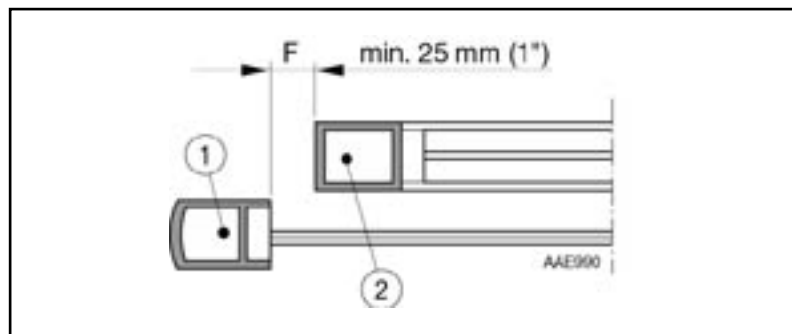

F= Safety distance (finger protection)

- ① Door leaf
- ② Vertical rail of the sidelite leaf
- ③ Door stop

Checking and adjusting the belt tension

The belt tension is factory-adjusted and readjustment is normally not needed. If despite this the belt tension has to be corrected proceed in the following way:

1. Loosen the two fixing screws ①.
2. Tighten the belt adjustment screw ② to a torque of $2 \text{ Nm} \pm 0,25 \text{ Nm}$
($283 \text{ oz}\cdot\text{in} \pm 35 \text{ oz}\cdot\text{in}$)
3. Tighten the two fixing screws ①.

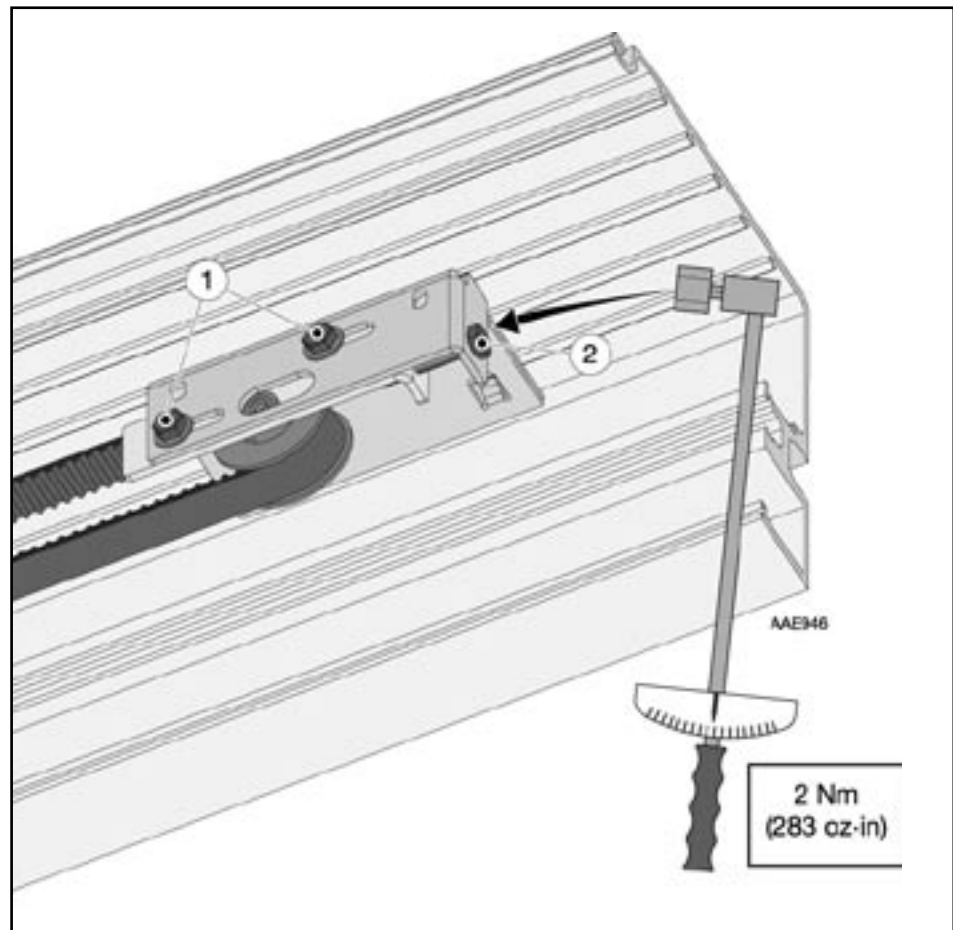

Interlocks for FBO units

Slide the active leaf(s) into the closed position and check to see that the interlock hardware engages the sidelite cutouts. Adjust (and shim if necessary) for proper alignment.

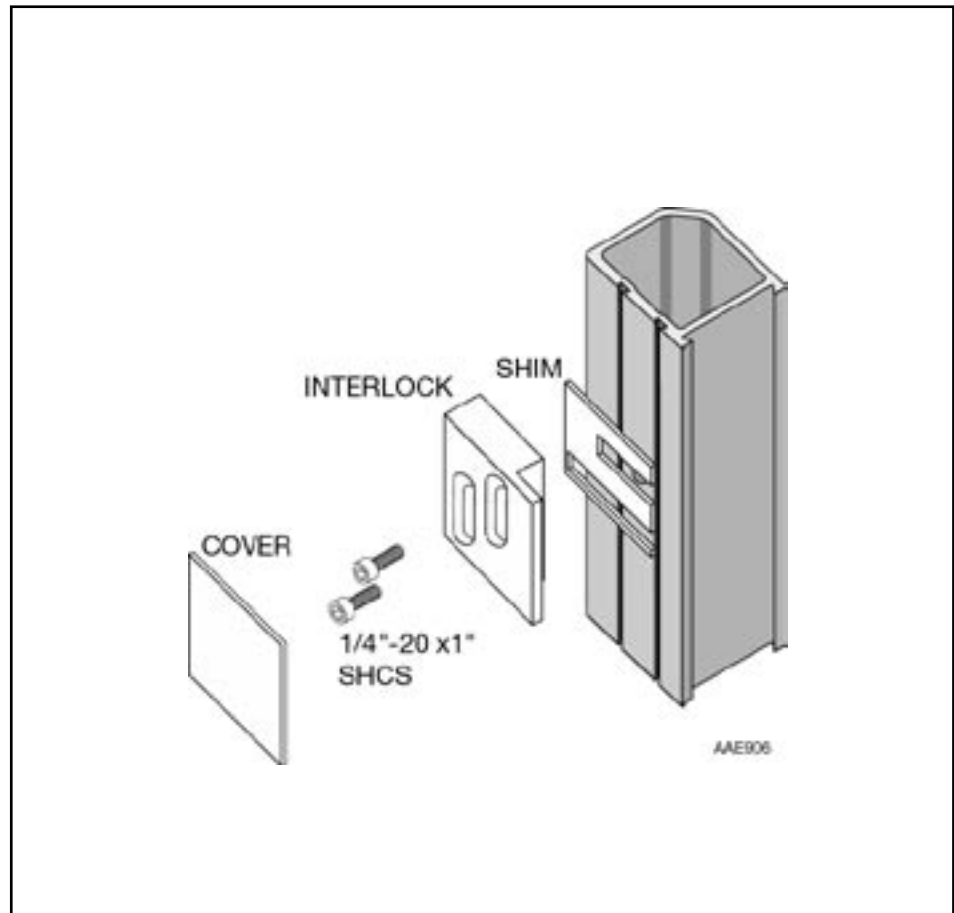

Adjusting ball catches

1. Check that the sidelite door assembly engages properly with the sidelite header assembly. Both can be repositioned slightly if necessary.
2. Adjust the tension on the ballcatch by turning the adjustment screw, as required by local egress codes. Tension is not to exceed 50 lbs. break out force; see page 55 for ANSI/BHMA standards.

A magnetic panic break out switch (bi-parting units have two) shuts the operator off when the sidelite is opened. A ceramic magnet is located in the upper horizontal sidelite rail. The switch(s) are located over the magnet in the lower edge of the support plank. The magnet location can be field adjusted by loosening the bracket mounting screw. See page 47 to wire the break out switches (terminals 10 and 13).

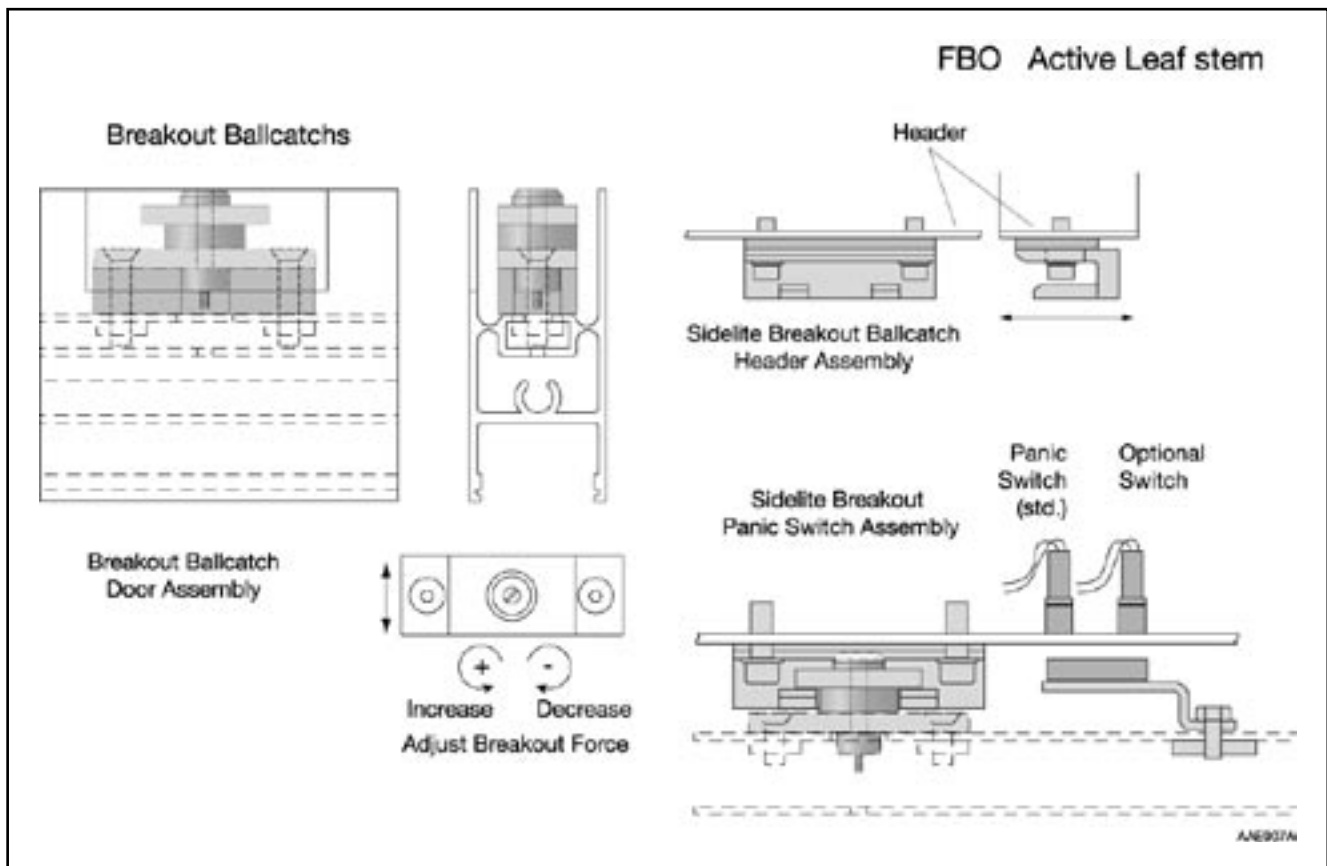

Note! FSL fixed Sidelites utilize a strip magnet on top rail of the active panel and a reed switch in the sidelite.

Manual lock system adjustment and re-keying

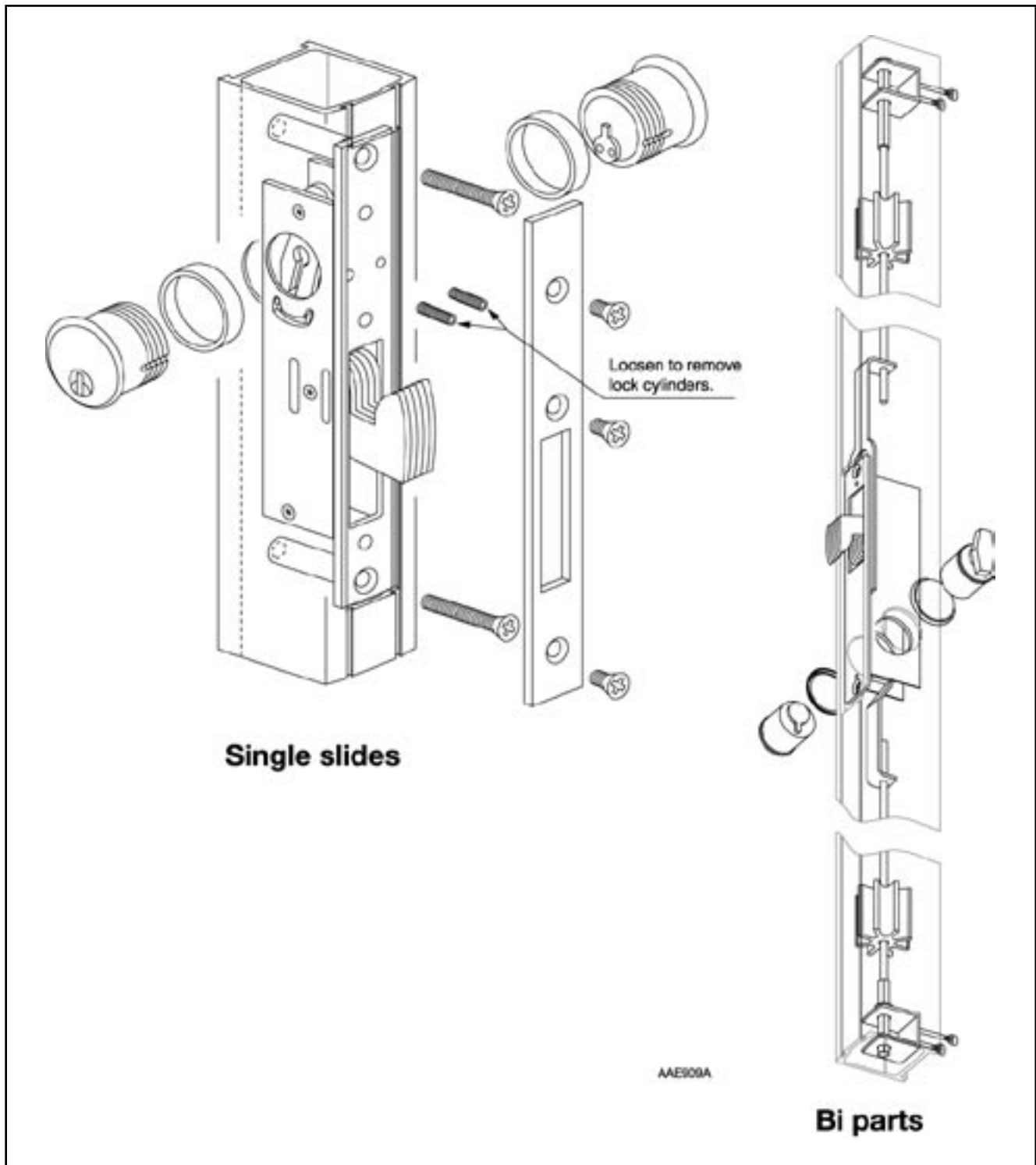

Installing/Removing the cover

For single-sliding operators two pre-mounted rotary locks are hooked into a groove in each end of the cover and tightened. Bi-parting operators may have a third lock in the center. When the cover is closed the rotary locks fit into a groove in the support beam. By turning the locks clockwise the cover is secured.

Installing

1. The rotary locks are made rectangular with guide grooves to secure the horizontal position. Make sure they are turned “horizontally”.
2. Fit the upper part of the cover into the hinge and place the support tool to keep the cover open.
3. a) Connect the cable coming from the program selector (if installed in the cover) to the modular socket in the control unit (see page 47).
b) If UniScan is installed, do not connect it to the control unit CU until “Start-Up” on page 51 has been carried out (see also separate installation manual for UniScan IAA015).
4. Remove the support tool ③ and push the lower part of the cover in against the support beam.
5. Make sure the rotary locks fit into the groove. Fasten the cover by inserting a 10 mm standard wrench from the underside and turn the rotary locks clockwise (approx. 90°). Test to ensure engaged and locked.

Removing is made in reversed order

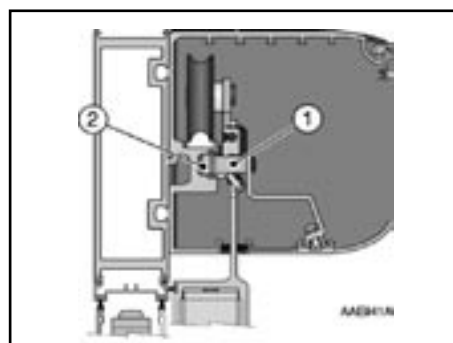
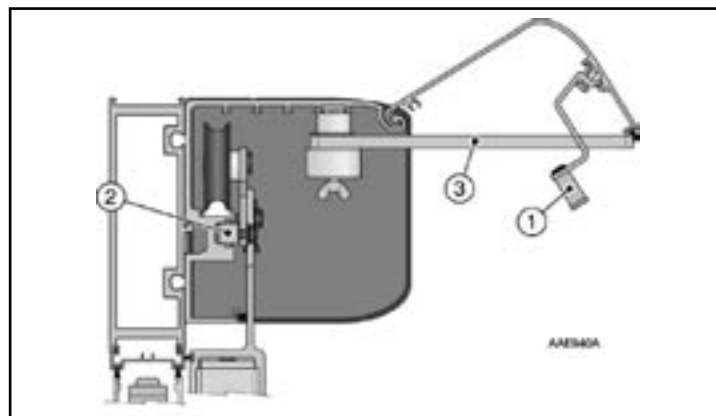

Note! On exterior covers using electrical locks, use manual unlocking device MOLD

- ① Rotary lock
- ② Groove in the support beam
- ③ Support tool

Transom

Flush Glaze Only

- 1: *Pull-In Vinyl* installed prior to frame assembly.



- 2: *Roll-In Vinyl* installed after setting glass.



Universal

- 3: *Push-In Vinyl* gutter and stop installed on top of operator header for flush glaze.



Transoms are supplied as standard with a flush glazing system for 1/4" glass (page 43). This system has no visible glass stops in the vertical and transom header channel extruded elements.

Alternate systems are available (pages 44-45) with readily visible snap-in gutter members and different glass stops with push-in vinyl to accept either 5/8" or 1" Thermopane lites.

1/4" Flush Glaze (Page 43)

5/8" Thermopane (Page 44)

1" Thermopane (Page 45)

Each system has jambs in the form of hollow extrusions which can be field cut in order to fit the frame into tight finish opening widths. The transom header assembly (compensating channel) permits increasing or decreasing overall frame height by as much as 1". The flush glazed system has fewer glazing components and is less labor intensive to install.

Note: In a flush glazed system, certain installation steps must be carefully followed when installing the pull in glazing vinyl. The pull-in vinyl (type 1, above) must always be installed prior to assembling the frame. The pull-in vinyl in the vertical jambs must be temporarily positioned below the operator header (to prevent damage) until all anchoring procedures have been completed.

 Transom cont.

General preparation

Carry out site inspection (see page 18) Establish the overall frame width (FW) and overall frame height (FH). Check that all components are available.

Unpackage transom header channel (3) which is the same length as the FW and check fit at various points in the opening height. If the header channel fits properly, the sliding door package will fit also.

Note: If the rough opening is determined to be short, one or both jambs (hollow) may be carefully field cut (maximum 3/4" each jamb) as desired. Be certain to cut header channel also.

Establish the high point of the finished floor (FFL) and the finished opening height (FOH). Lay the header channel, unexposed side down, across the finished opening. Shim, level and measure the distance from the underside of the channel to the underside of the finished opening header. This measurement is the finished opening height (FOH) and can be no larger than 3/4" or smaller than 5/16" of the established FH.

The transom header channel is adjustable (see below) to allow for differences between the FOH and the FH.

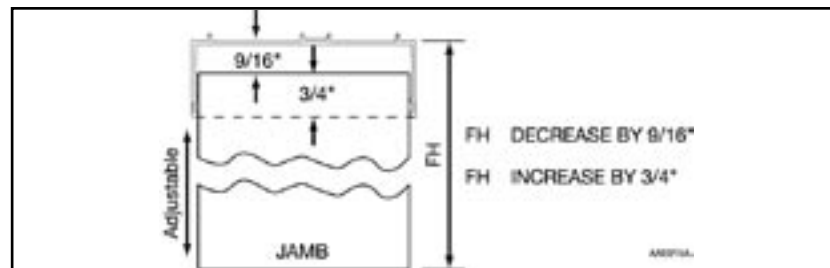

Frame preparation

Position the right and left jambs in their proper position in the finished opening. Mark the desired anchoring points. It's important that the jambs are shimmed to the established finished floor height before marking. Drill necessary anchoring clearance holes. Be certain to countersink all anchoring holes located in the transom area. This will help to prevent glass breakage when setting the transom glass. Due to clearances, the countersink tool must be slid down from the top of the jamb tubes.

Reposition both prepped jambs to their permanent position in the finished opening, shim jambs to the finished floor height, then plumb, level and drill (see page 23 for guidelines). Use jamb anchoring notes as template for appropriate anchoring locations. Remove jambs, complete drilling procedure and install anchoring shields if required.

Carefully remove header channel inserts (4). Drill anchoring clearance holes 1-1/2" from the center line of the header channel (see below).

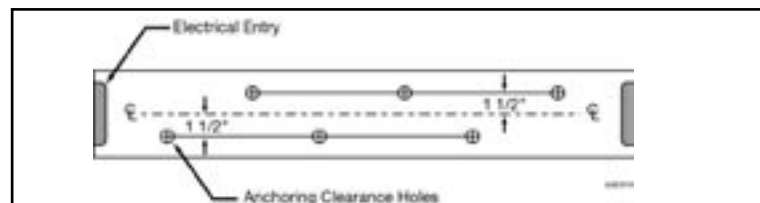

Transom cont.

IMPORTANT Flush glaze system

Install pull-in vinyl (6) to the exterior side of all channel inserts (4) and all transom mullions (9).

Cut two lengths of pull-in vinyl (6) to fit between top of jamb tubes (1) to the top of the operator. Install vinyl (6) to the exterior side and tape temporarily to prevent damage in the operator area of jamb tube. See diagram below.

Note: Vinyl will be pulled up into transom area after all anchoring procedures have been completed.

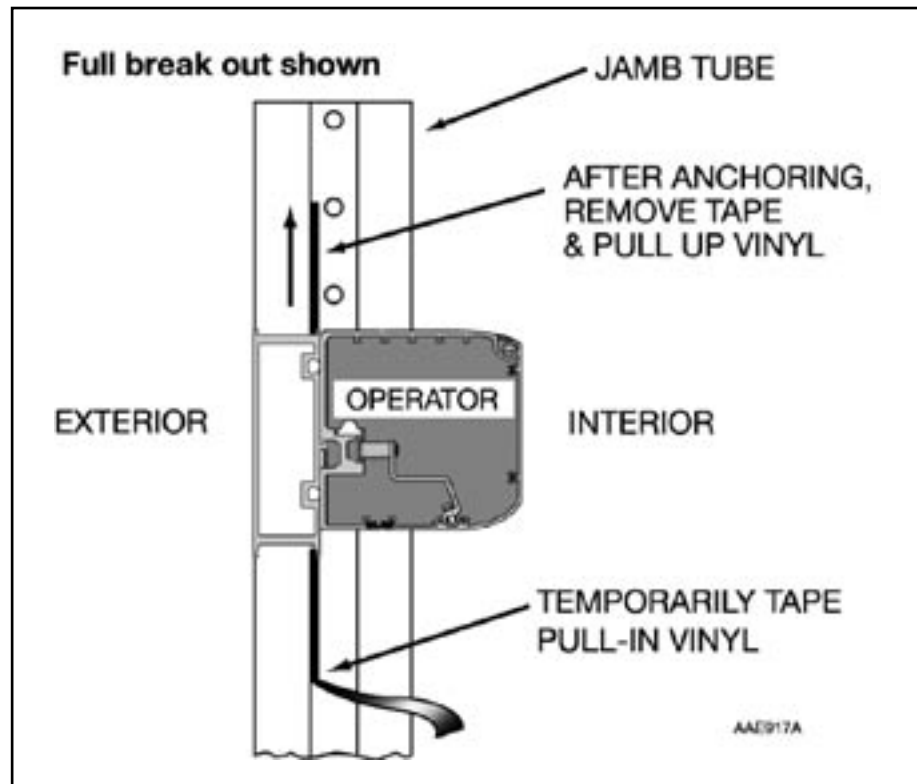

Secure both jambs (1) to the plank. Check to see that vinyl (6) is free and can be easily repositioned into transom area.

Install into the top of plank and tight to jamb tube (1) the appropriate length of snap-in gutter member (13). This will correctly locate the transom mullion (9) and proper positioning of transom mullion clip (10). Secure mullion clip with mounting screws (11).

Install transom mullion(s) (9) and remaining gutter members. Push-in vinyl (15) can be installed into all gutter members (13) and glass stops (14) at this time.

Transom cont.

Setting the frame

Install transom header channel (3) by carefully sliding it over and completely down on all transom verticals. Position frame in its correct position (pre-drilled anchoring holes must align) in the finished opening. Shim jambs in the operator area until frame is centered and secured in the finished opening. Check level of operator.

Plumb and secure one jamb. Measure FW at the operator height, shim and secure opposite jamb at established FW measurement. Measure clearance, at several points, between the finished opening header (see fig. 6) and the top of the header channel (3). Measurement must be 1" or smaller and finished opening header must be level to within 1/4". Perform the following header channel adjustments according to conditions.

Clearance 1" or less – Push header channel (3) tight to opening header and secure.

Clearance 1-1/8" or greater – Shim between header channel (3) and header opening and secure.

Out of level – If more than 1/4", shim header channel (3), level and secure.

Install header channel inserts (4) and secure verticals to channel with self-tapping screws (8). Note: Be certain inserts have pull-in vinyl (6) installed and positioned to exterior (Note! FSL will be interior).

Measure transom glass requirements (Flush Glaze System Only):

Width = daylight opening plus 3/4".

Height = daylight plus 9/16".

Install transom glass. Block and install roll-in vinyl (7).

Install jamb tube closures (2), then proceed to install the rest of the door system.

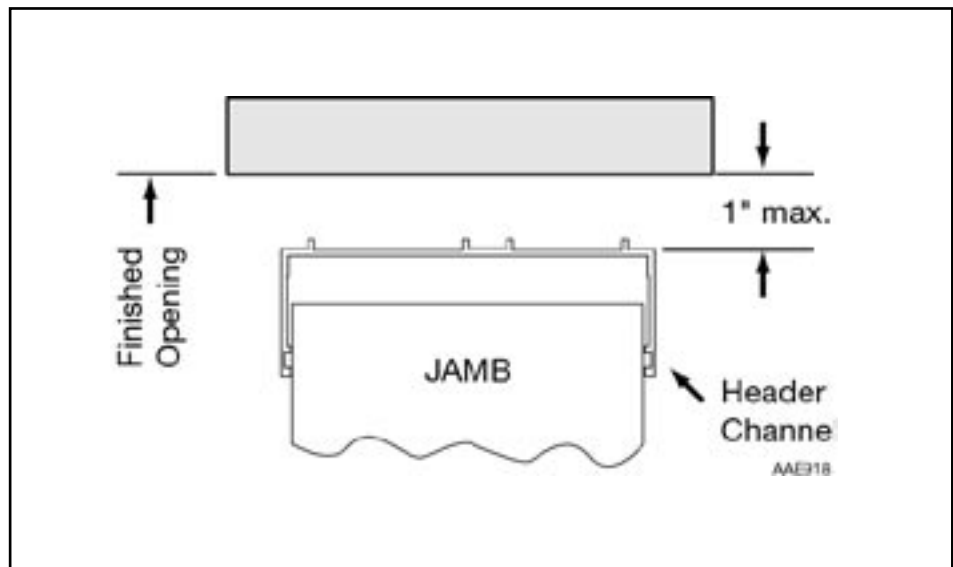

Transom cont.

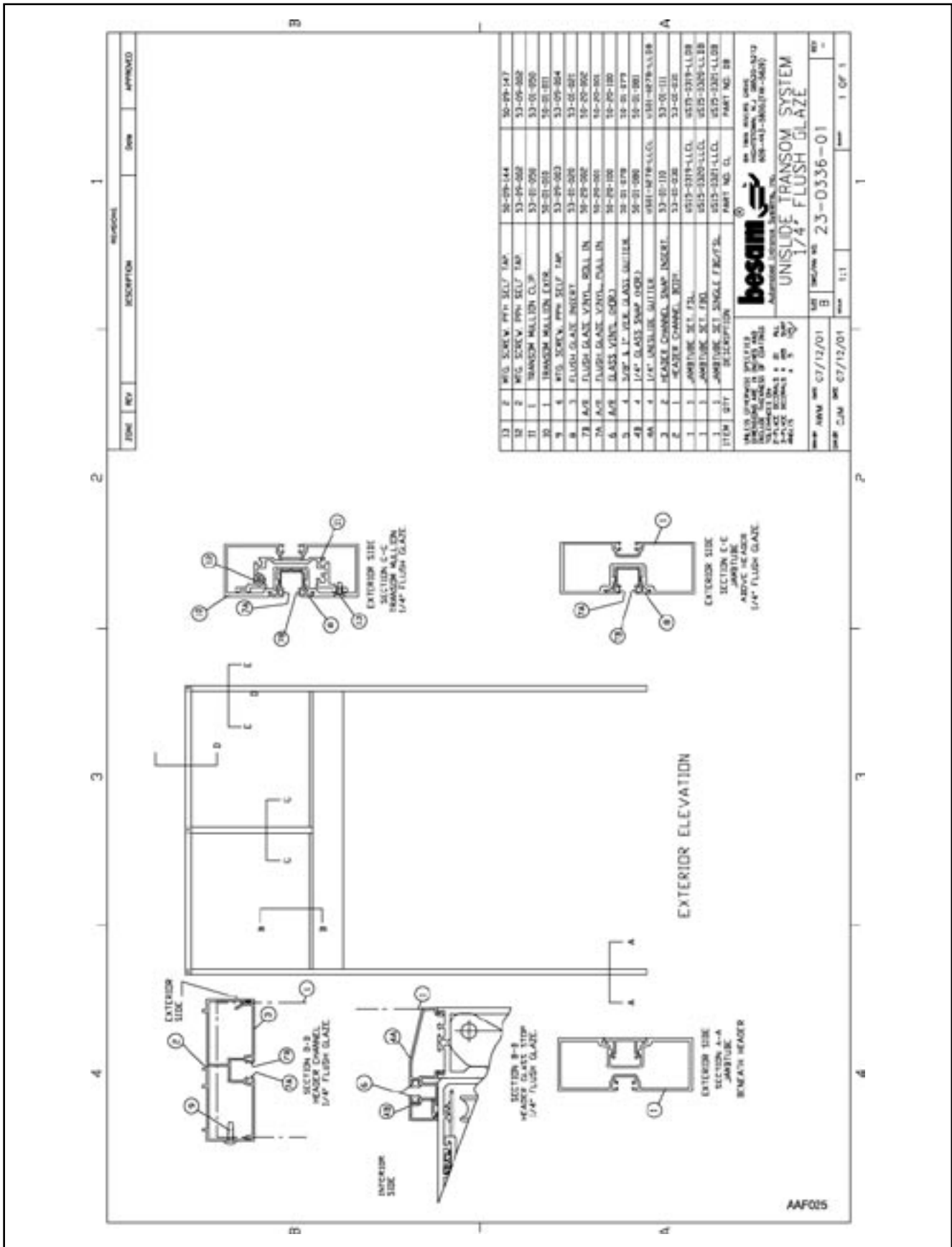

Transom cont.

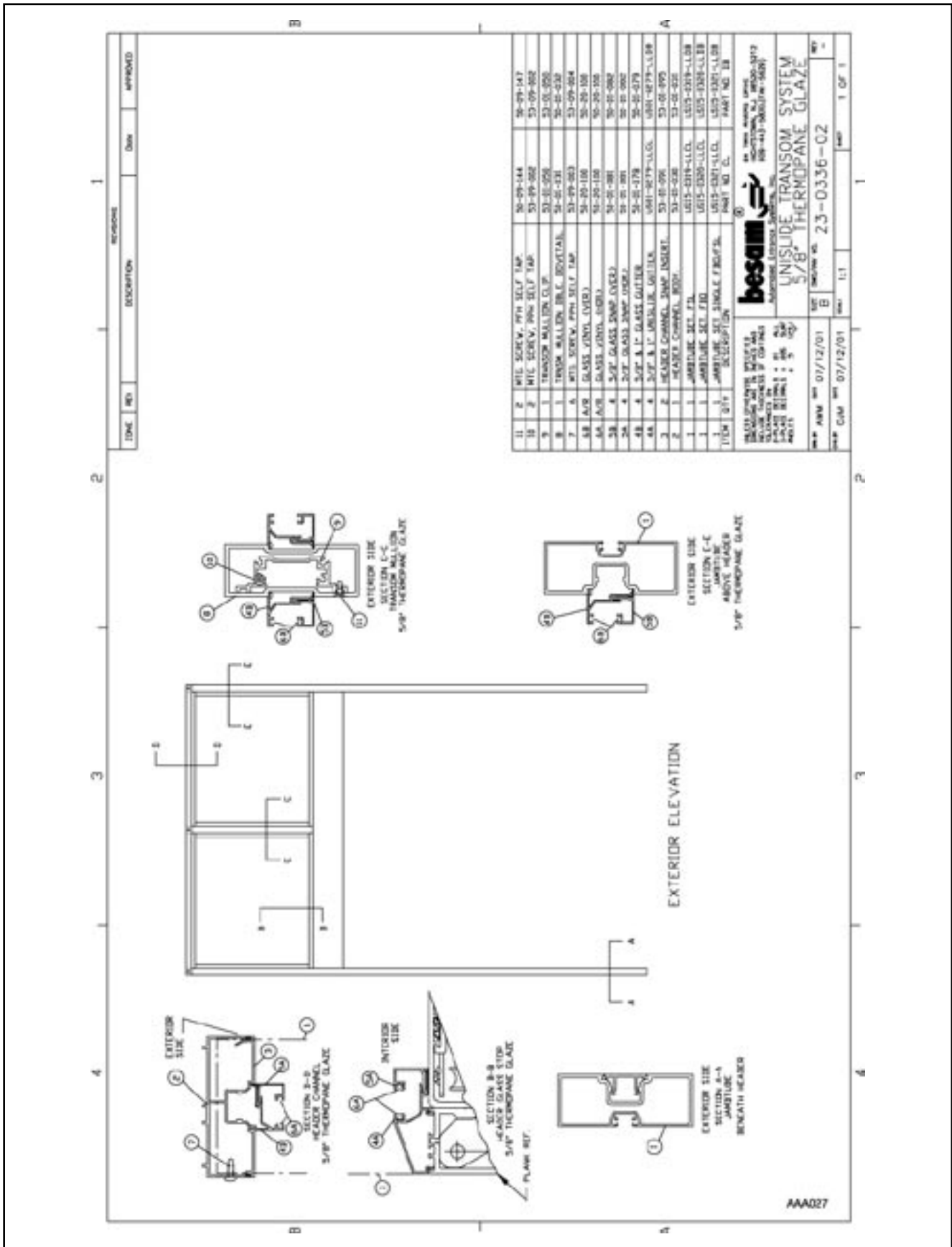

Transom cont.

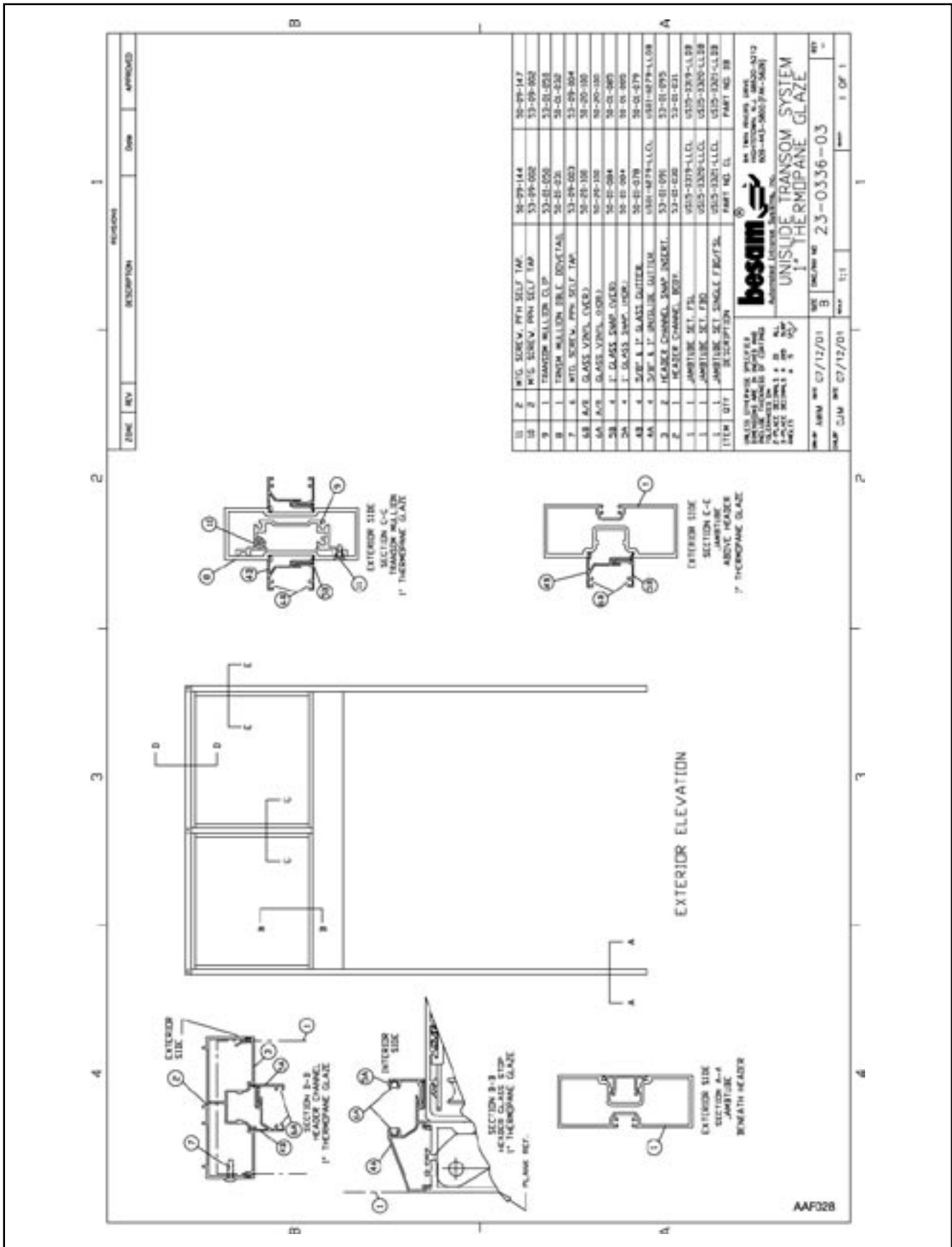

Note!

During any work with the electrical connections the
- **main power** and the
- **electronic emergency unit must be disconnected.**

A suitable Lockout is required for OSHA regulation compliance and highly recommended for personal safety.

Installation

1. Open the cover (see page 38).
2. Install extension unit EXU-1 or EXU-3 if required (see page 51).
3. Install and connect the main cables (see below).
4. Install, but do not connect activation units, presence sensors and accessories.
5. Carry out "Start-Up" (see page 54).

Note! Basic adjustments and function selections can be carried out with the potentiometers and the function selector on the control unit (see page 48).

Main connection

1. Remove the cover plate from the work box.
2. Connect the incoming main power through the strain relief
 - White wire to white wire
 - Black wire to black wire
 - Green wire to green wire
3. Replace the cover plate

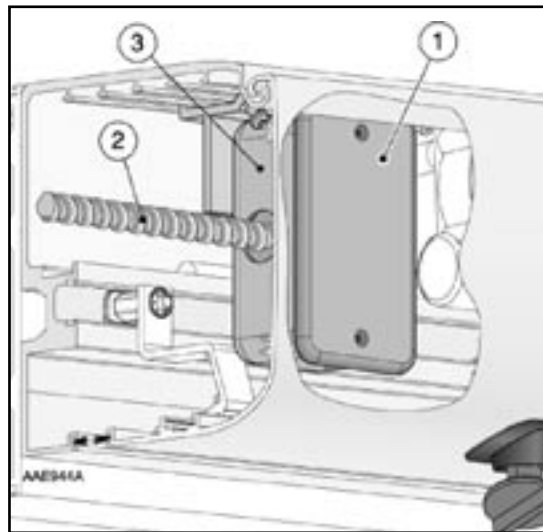

- ① Cover plate
- ② Mains power
- ③ Work box

The control unit is equipped with:

Contacts for connection of standard units

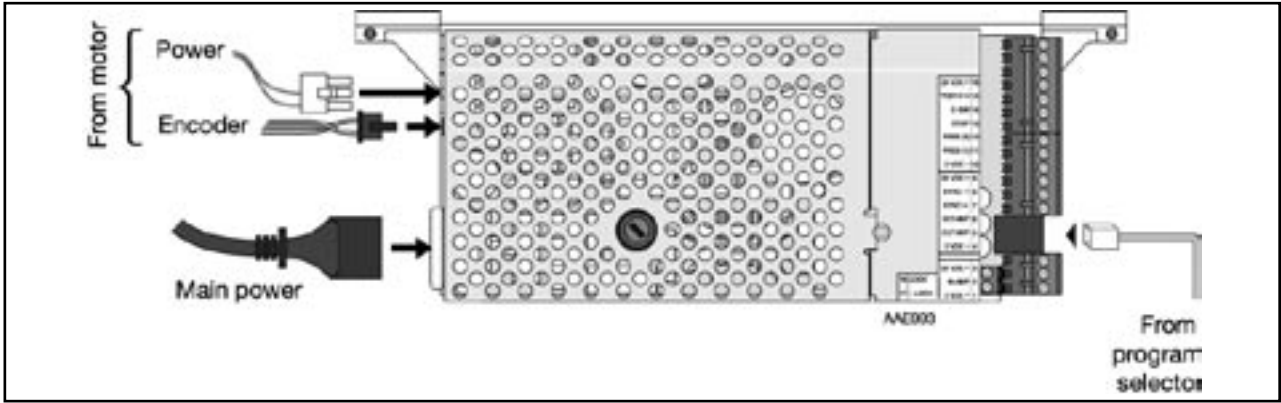

Terminal block for connection accessories

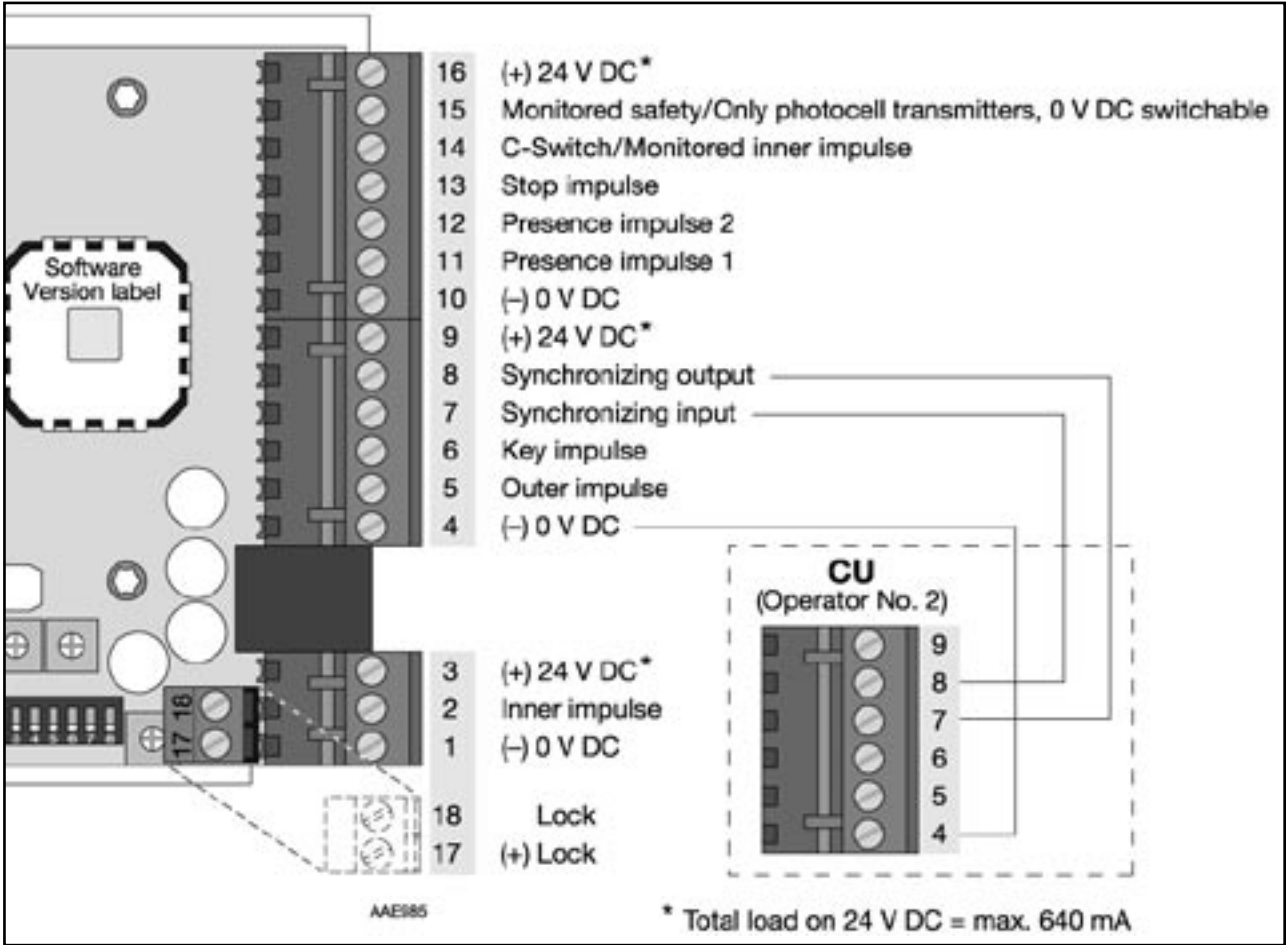

Note! To be able to adjust the functions below the lid must be removed (see page 49).

Function selector, FS, used to select special operating functions

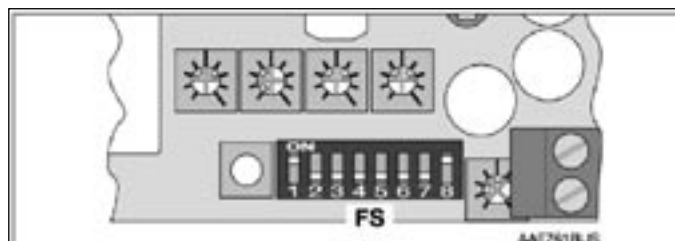

Function selector FS	OFF	ON
1. Belt travel direction on opening facing cover side	CW	CCW
2. Lock configuration (locked with/without power)	With	Without
3. Lock release ¹	No	Yes
4. Presence detection type (normally open/closed) ²	NO	NC
5. Emergency unit type ³	Electric.	Mech.
6. Emergency unit monitoring	No	Yes
7. Inner imp. monitoring & No. of monit. pres. imp.	No&0	Yes&1
8. Hold force on closed door ⁴ (0 N / 45 N)	No	Yes

- ¹ If “Lock release” is active, the door will apply force in the closing direction when the lock is unlocked. This is made to prevent a lock from being stuck in locked position when opening.
- ² Applies in common for the terminals 11, 12 and 13 on the control unit CU.
- ³ Choose between “Electrical” (Battery) or “Mechanical” (Rubber band). If no emergency unit is installed the parameter should be set to “Electrical” (default setting). When convenience battery is used the function selector FS-5 must be set to ON (Mechanical).
- ⁴ Used to **keep** the door in closed position.

Potentiometers and learn button

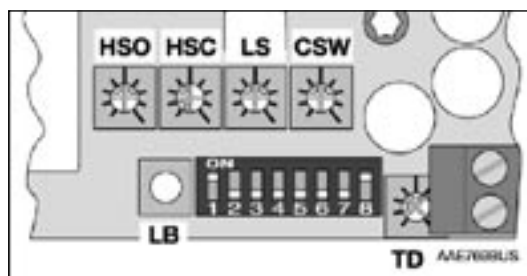

Note!
Potentiometers factory settings
see arrows on potentiometers

Parameter (speed applies to single panel)		
HSO:	High speed opening	0.10 – 0.70 m/s (0.33– 2.30 ft/s)
HSC:	High speed closing	0.10 – 0.70 m/s (0.33– 2.30 ft/s)
LS:	Low speed	0.05 – 0.70 m/s (0.17– 2.30 ft/s)
CSW:	C-switch distance	Min. = 0 mm / Middle = 700 mm (2.3 ft) / Max. = 1400 mm (4.6 ft)
TD:	Hold open time	0 – 60 s (setting applies also to “Partial Hold Open Time”)
LB:	Learn button	

Connection of program selectors

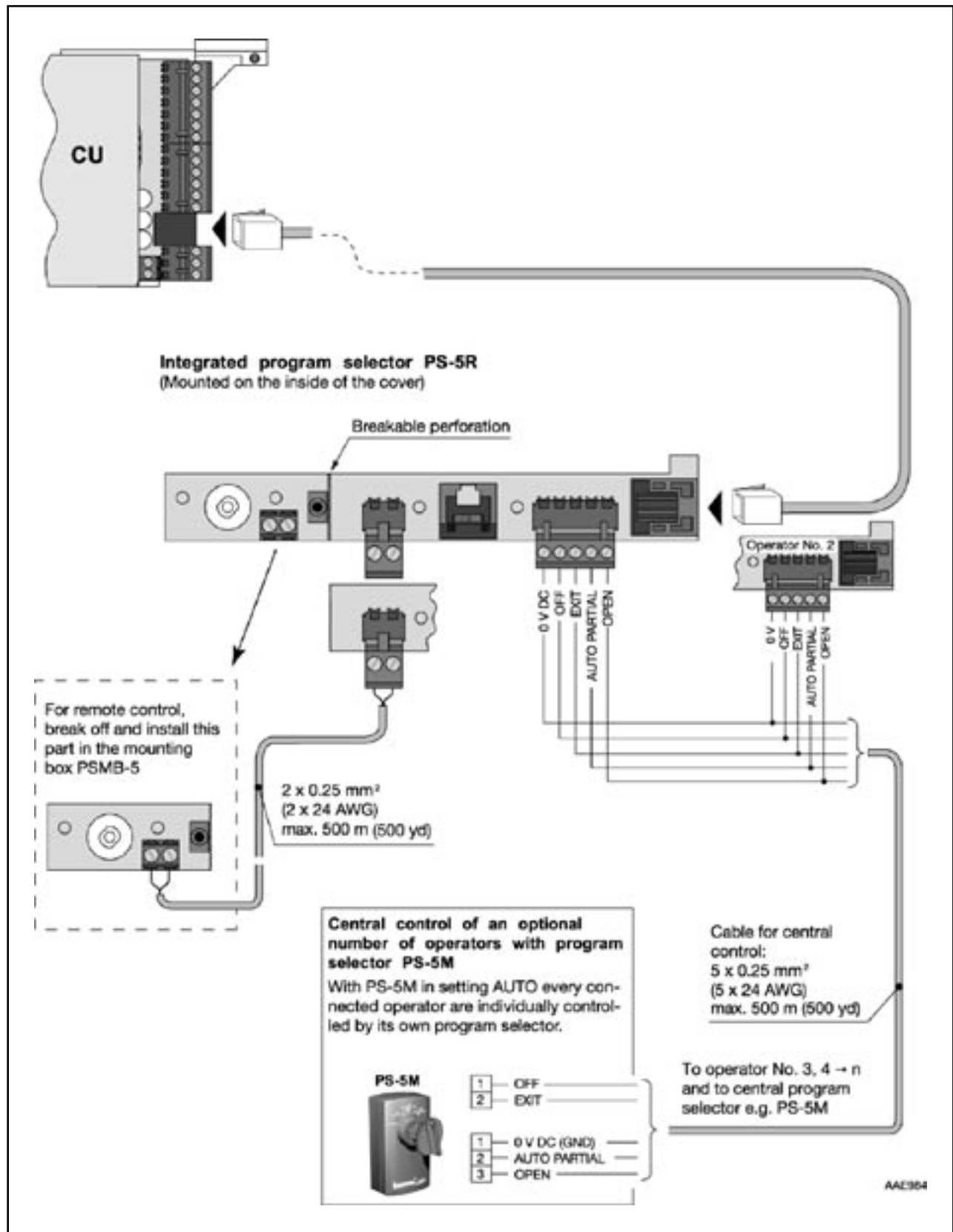

Connection of activation units

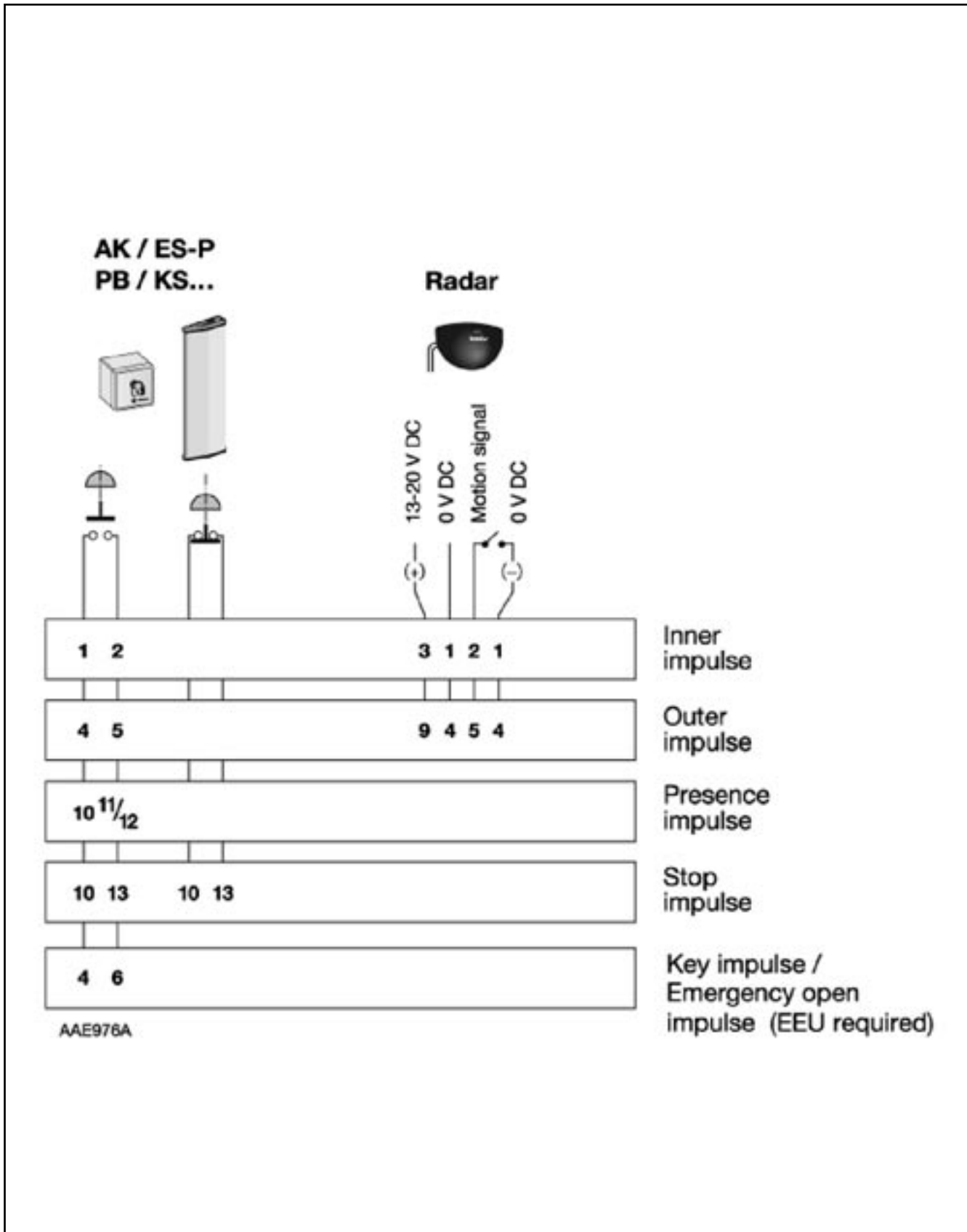

When functions beyond those implemented on the main control unit are required, two extension units are available, EXU-1 and EXU-3. These units are to be applied on top of the control unit.

Fitting the extension units EXU-1 or EXU-3 to the control unit CU

- ① Fastening screws (2 pcs)
- ② Inter connect strip (long pins to be fitted into the EXU)
- ③ Extension unit, EXU-1 or EXU-3
- ④ Label (EXU-1 or EXU-3)
- ⑤ Lid
- ⑥ Screw to fix the lid

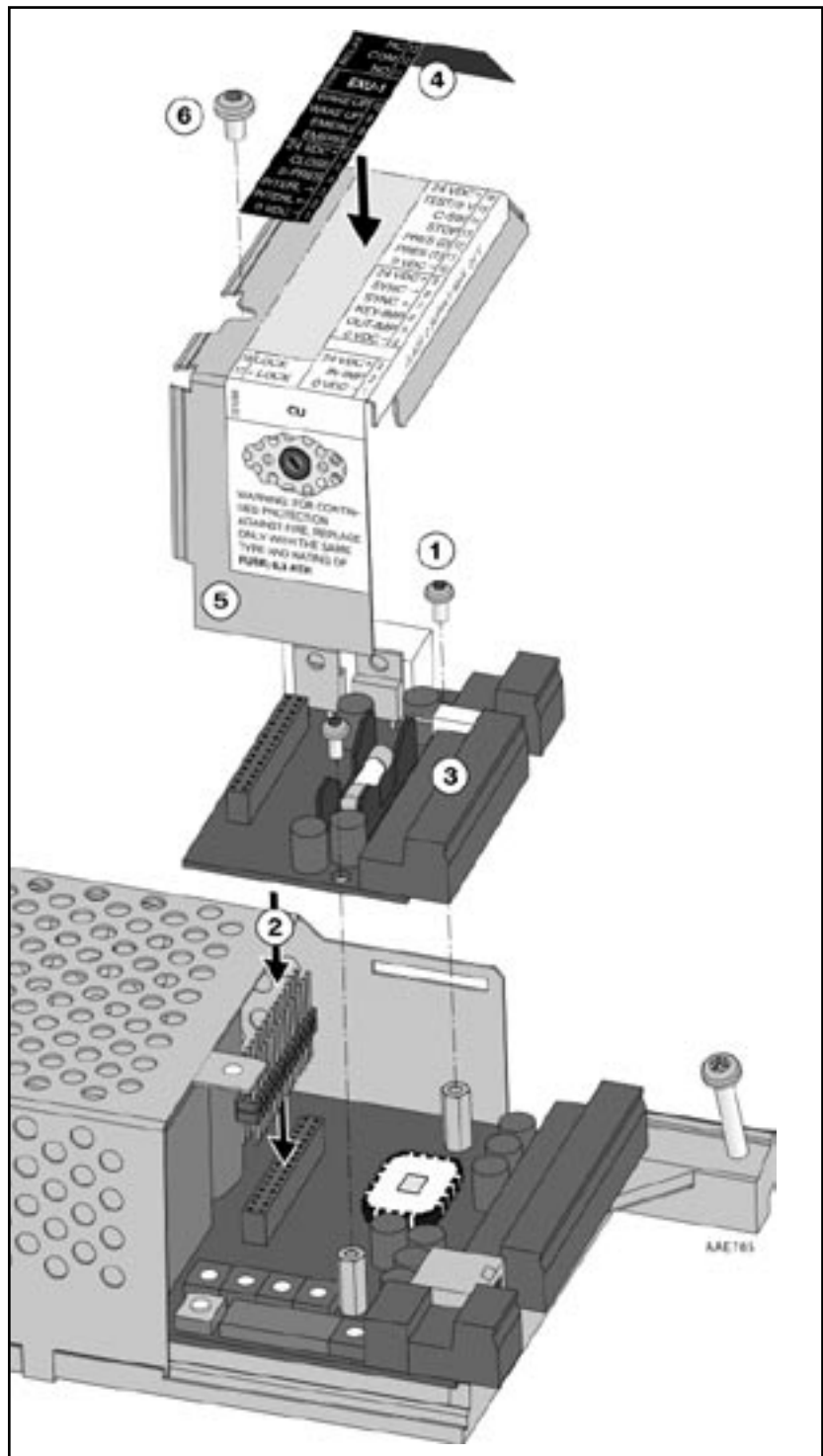

Extension unit, EXU-1

Following functions can be obtained with this unit:

1. Connection of Error/Status indication relay.
2. Connection of “emergency opening push button” (fireman's opening).
The cable from the emergency unit (battery) is to be connected to the EXU-1.
3. Connection of interlocking

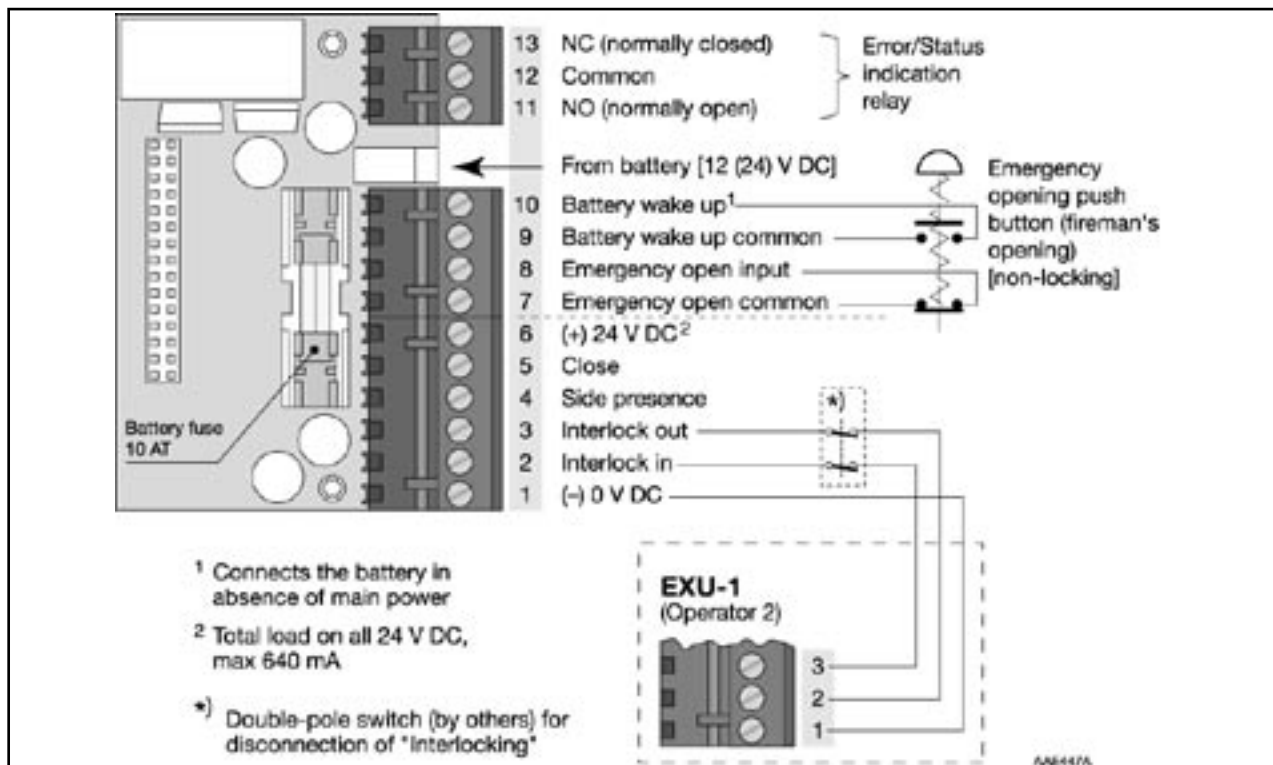

Extension unit, EXU-3

This extension unit has only one function (**electrical emergency opening**) which opens the door in absence of main power.

The cable from the emergency unit (battery) is to be connected to the EXU-3.

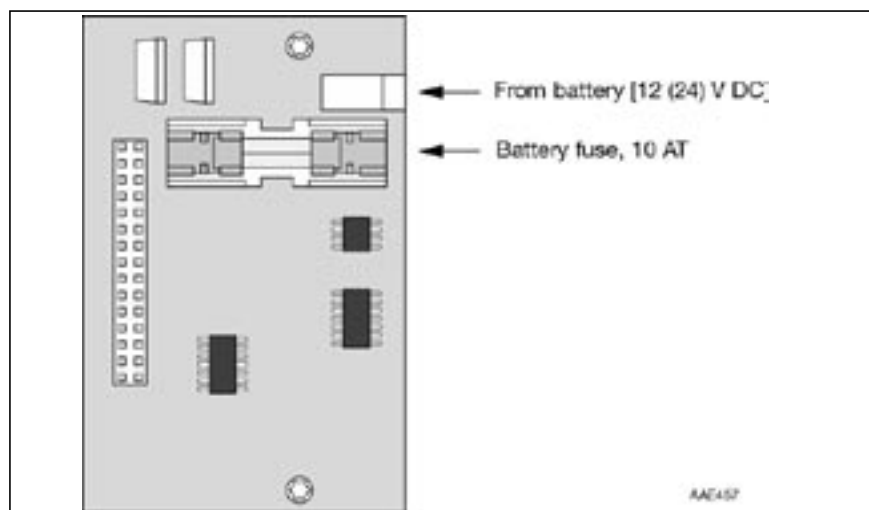

Convenience battery UPS (stand-by supply)

The convenience battery UPS makes the door operate normally in short absence of main power.

1. Remove the diode D10 (EXU-1) or D9 (EXU-3).
2. Set the function selector FS-5 to ON (Mechanical).

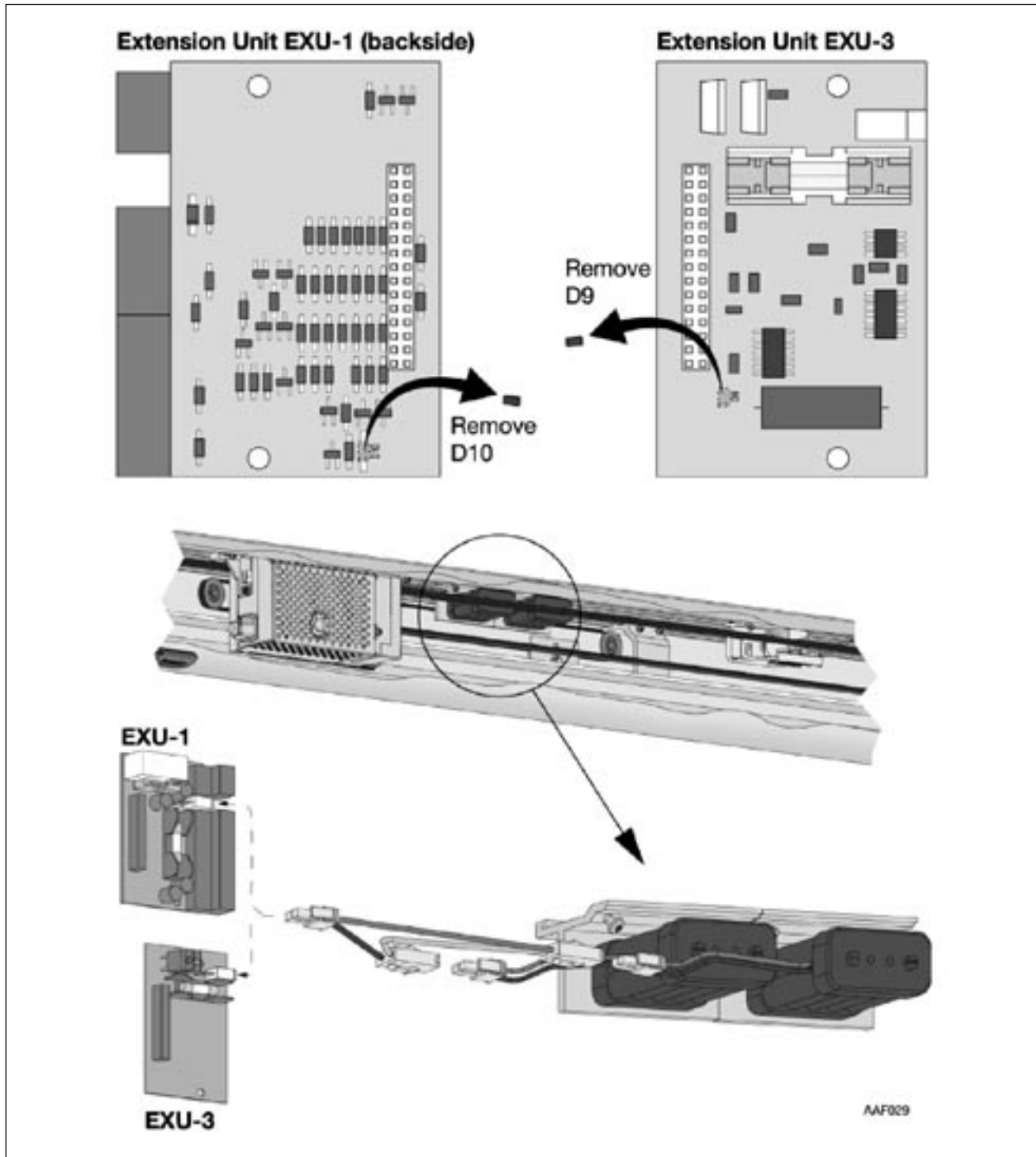

After installing the operator, the Start-up and adjustment must be carried out in the following order (see also electrical connections).

1. If a lock is installed, make sure the “Lock configuration” is correctly set (locked with or without power) and that lock release is correctly set to Yes (ON)
2. Make sure that correct belt direction of rotation is selected, CCW or CW, (see page 48).
3. Disconnect UniScan teleplug.
4. Set the program selector PS-5 to “Auto”. Apply the main power plug to the control unit. If the door is open and no opening impulse is active, it will move to closed position with low speed.
5. Push the learn button, LB (see page 48). The operator will carry out a complete open/close cycle at low speed to learn the opening width and the closed position.
6. To check the door movement, give opening impulse by shorting the terminals No. 1 and 2 on the control unit.
7. If necessary adjust the door speeds with the potentiometers to the required values (see page 48).
8. Select correct functions with the function selector FS, for the accessories to be connected (see page 48).
9. Press UniSlide “Reset”.
10. Disconnect the main power, install activation units and accessories and reconnect UniScan.
11. Connect the mains power and check that the installation complies with valid regulations and requirements from the authorities.

Note! The door must stand still when adjustments are carried out.

Program selectors and functions

Operation

The functions of the door are set with key program selectors:

- PS-5R, recessed in the cover, can be remote-controlled by PS-5M.
- PS-5M, flush or surface mounted, for central control of an optional number of operators. In setting “Auto” every connected operator are individually controlled by its own program selector.
- PSMB-5, mounting box, flush or surface mounted on the sidelite or on the wall close to the door.

Recessed in the cover



Flush mounted



Surface mounted



Program selector functions

--	“Off”	The inner and outer activation units are disconnected. The door is locked if an electromechanical locking device has been installed. The door can be opened with an emergency push-button/key switch (if installed).
- ↑ -	“Exit”	Passage through doorway from inside only. The door is locked if an electromechanical locking device has been attached. The door can only be opened with the inner activation unit and with an emergency push-button/key switch (if installed).
- ↑↓ -	“Auto”	Two-way traffic, normal operation of the door. The door can be opened with the inner and outer activation units and with an emergency push-button/key switch (if installed).
- ↑↓ -	“Auto partial”	Two-way traffic. The door can be opened partially with the inner and outer activation units and with an emergency push-button/key switch (if installed).
- -	“Open”	The door is permanently held open.
	“Reset”	Set the program selector to “Auto”. Insert a narrow object in the small hole on the program selector board and push. The operator makes a system test of the battery, electro-mechanical lock, watch dog relay and closed position. It also reads FS switch settings, CSW distance and Time delays. After closing the operator is reset and ready for normal operation again.
	“Learn”	Learn can only be achieved by pressing the learn button on the control unit. The door must stand still, either open or closed. The door opens as much it can and clears its position register, then it closes as much as possible and calculates and saves the opening width. Closed position is always zero and open always the calculated opening width. Learn is normally only performed when the door is installed and never more. The door adapts temporarily to obstacles but never changes its learned opening width.

Sign Placement

ANSI/BHMA standard 156.10-1999 and Besam standards specify that caution signs must be affixed to both sides of any power operated pedestrian door. With double doors, signs should be applied to each door.

Sliding doors with swinging (break out leaves) shall be provided with signs reading "IN EMERGENCY PUSH TO OPEN". The signs shall have red backgrounds with contrasting letters one inch high minimum. The signs shall read horizontally and be located adjacent to the lockstile on a center line 36 inches minimum and 60 inches maximum from the floor, applied to the side appropriate for egress. ANSI/BHMA A156.10 . In addition, the sign "AUTOMATIC DOOR" with letters 1/2" high minimum will be applied to the door, visible from both sides. If switch activated, use "AUTOMATIC DOOR - ACTIVATE SWITCH TO OPERATE"

Note – the kit decals are double-sided and normally will only need to be applied to one side of a clear glass door. If the decals are not clearly visible on the other side due to the condition of the glass (e.g., tinted or textured glass), the decals should be placed on both sides.

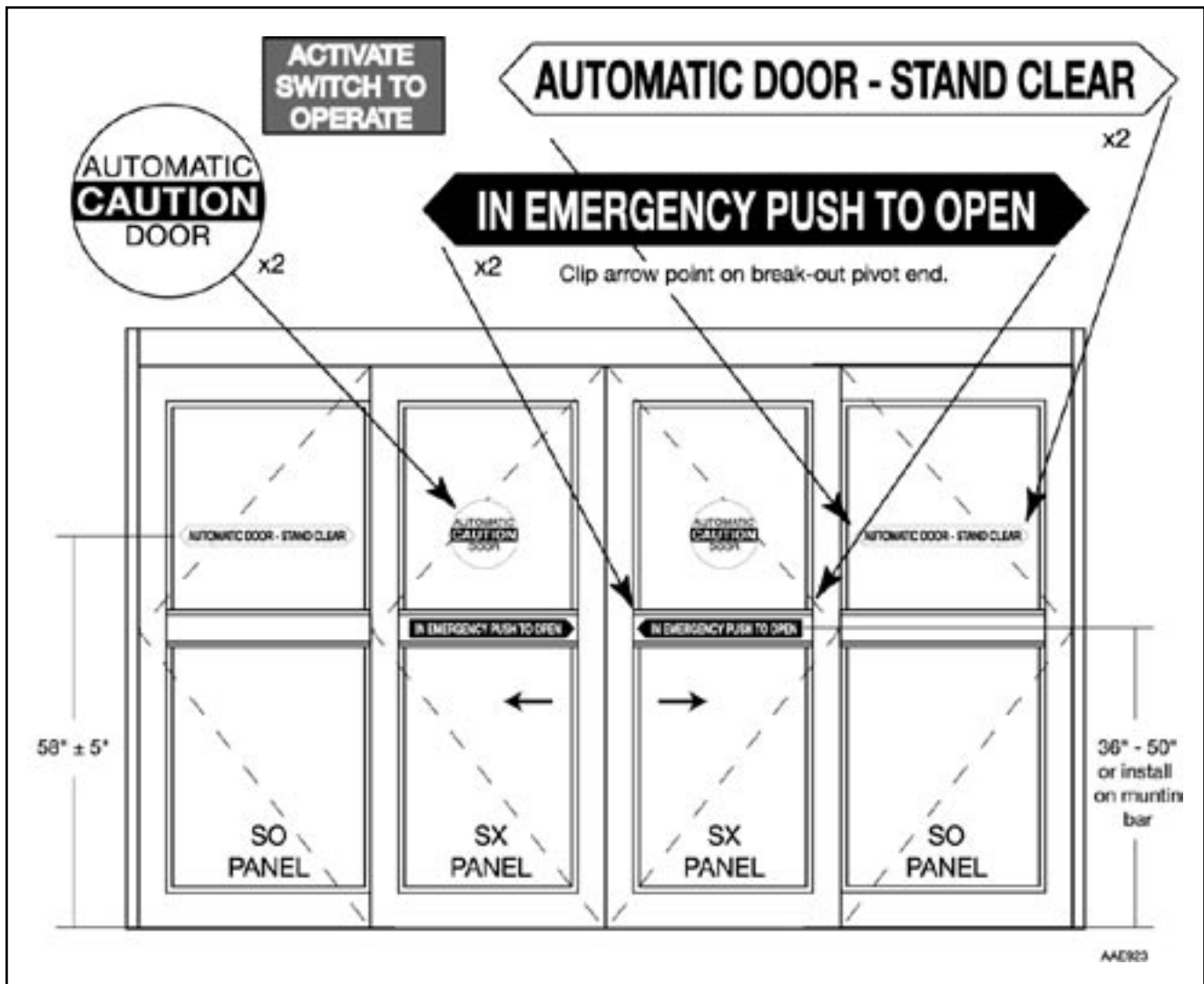

Always start any troubleshooting by checking the mechanical and electrical parts of the operator in the following order.

The control unit, emergency unit and electromechanical lock are fixed with brackets in the support beam. To replace, the complete unit is to be loosened and replaced.

1. Mechanical checking and remedies

Disconnect the main power. Remove the tooth belt from the tooth belt fitting. Pull the door leaf manually and check that the door can be easily moved over the complete sliding track/floor guide. If the door leaf stops or is hard to move, the reason may be sand, stones, rubbish etc. in the floor guide. The door leaf may also be jamming on the floor or on the weather brush. Clean the floor guide, adjust the door leaf height/depth or take other necessary measures until the door leaf is running smoothly when manually operated. Repeat for the other door if bi-parting.

2. Error indication

During normal operation the light emitting diode (LED) on the control unit is illuminated.

A flashing light on the LED or an extinguished LED indicates that the operator is out of function or waiting for monitoring acknowledgement.

LED

FLASH FREQUENCY	REASON	REMEDY
4 fast flashes, pause; repeats	Motor temperature high	Wait one minute for the operator to recover. If necessary replace the control unit
2 fast flashes, pause; repeats	EEProm access error	Reset the operator. Replace the control unit if necessary
Continuos; no pause	Battery system	Check battery connection Check battery fuse Check that battery is charged
	Motor/Encoder	Check motor connection Check encoder connection Check door moves with low friction Check that EXU-1 or 3 is seated properly Replace the motor/encoder unit Replace the control unit
	Processor error	Press reset

3. No Error Indication, no Control LED illumination

1. Check Fuse
2. Check Mains Power
3. Check Main Wiring

4. After remedy or replacement the operator has to be checked as follows:

1. Study the door movement and adjust the functions to the values required for a smooth door operation.
2. Check that correct functions and values have been selected for the installed accessories and that the installation complies with valid regulations and requirements from the authorities.
3. Clean the cover and the doors.

From American National Standard for power-operated pedestrian doors. Please refer to full standard if necessary, obtainable through BHMA at (212) 661-4261. All figures referred to below can be found in the full standard. Excerpts reprinted with BHMA permission.

Sliding Doors

Automatic Sliding Doors are flat panels that slide horizontally or linearly. These systems have a variety of configurations. No matter what the configuration or system, automatic sliding doors shall include sensors, or control mats and signage for the safety and convenience of the user.

For control mats, joining of control mats and performance requirements of control mats, refer to the full ANSI/BHMA standard.

Motion sensors shall detect a 28 inch (710 mm) minimum high person or equivalent and moving at a rate of 6 inches (150 mm) per second towards the center of the door within the detection areas described.

Presence sensors shall detect a 28 inch (710 mm) minimum high person or equivalent within the detection areas described.

8.2 Sliding Doors

8.2.1 Activating detection areas shall have a minimum width equal to the width of the clear opening measured at 15 inches (380 mm) and 30 inches (760 mm) perpendicular from the face of the closed door(s). The length from the face of the door shall be 43 inches (1090 mm) minimum measured at the center of the clear opening. Detection shall be effective to within 5 inches (125 mm) from the face of the door measured at the center of the clear opening. (See Figures A-13 & 18A, B & C.)

8.2.2 A presence sensor shall be used to prevent a fully open door(s) from closing when a person

is in the space between two non-overlapping activation detection areas. (See Figure 18A, B & C.)

8.2.2.1 If photoelectric beams are used (See Figure A-18A):

- 1) A minimum of two photo electric beams shall be installed with the lower beams installed 6"-28" (150-710 mm) and top beam 45"-55" (1145-1400 mm) from the floor; and
- 2) They shall be installed within 3" (76 mm) from the center of the slide door if both are installed on the same side or within 5" (125 mm) of the centerline of the slide door if more than two photo electric beams are installed on each side of the sliding door; and
- 3) The beams shall remain active from fully open to within 6 inches (150 mm) of closed.

8.2.2.2 If an area presence sensor is used through the door opening it (See Figure A-18B):

- 1) Shall detect a 28 inch (710 mm) minimum high person or equivalent and extend out a minimum of 5 inches (125 mm) from the face of the door on each side; and
- 2) The detection zone shall remain active from fully open to within 6 inches (150 mm) of close or shall have a photo electric beam at 6"-28" (150-710 mm) from the floor or a time delay of 4 seconds minimum after the activation signal ceases. (See Figure 18B.)

8.2.2.3 If presence sensors are installed on each side of the sliding door opening (See Figure A-18C):

- 1) They shall not have an inactive area more than 5 inches (125 mm) extending out from the face of the door. If the inactive area exceeds 3 inches, (76 mm) from the face of the door, one beam is required at 6"-28" (150 - 710 mm) from the floor; and
- 2) The detection zone shall remain active from fully open to within 6 inches (150 mm) of closed or shall have a photo electric beam at 6"-

28" (150-710 mm) from the floor or a time delay of 4 seconds minimum after the activation signal ceases. For Knowing Acts, see full standard.

10. Entrapment Protection

10.1 Entrapment Protection measures shall be taken under neutral air conditions.

10.6 Swing, sliding and folding doors utilizing sensors or control mats shall remain open a minimum of 1.5 seconds after loss of detection.

10.9 A stopped sliding or folding door shall not require more than a 30 lbf (133 N), measured at the leading edge, to prevent it from closing at any point in the closing cycle.

10.10 A sliding door shall be adjusted so that the closing speed is one foot per second maximum for doors weighing up to and including 160 lbs (71 kg) per leaf.

For doors weighing more than 160 lbs (71 kg):

$$V = \sqrt{(161 / W)}$$

V = Velocity in ft/sec

W = weight of door in pounds

11. Signage

For Signage, see full standard.

12.4 Break Away Device for Sliding Doors.

Sliding doors provided with a break away device shall require no more than a 50 lbf (222 N) applied 1 inch (25 mm) from the leading edge of the lock stile for the break out panel to open. Break away devices (swinging panels) for doors that slide on the egress side of an opening shall be equipped with a self-closing device or interrupt action of the operator when used in the break out mode. Break away devices incorporating swing out side lites shall interrupt actuation of the operator when used in the break out mode.

Planned Maintenance Checklist

To perform a proper Planned maintenance inspection, you must follow the checklist below. Please use your service tickets to note that this was done and record any problems discovered and the action(s) taken.

- 1. Visually inspect door operation.
- 2. Check activation and threshold detection devices.
- 3. Check for tripping hazards.
- 4. Check door function switch.
- 5. Check for proper operation of lock assembly.
- 6. Check for required signage.
- 7. Check for loose glass stops or damaged glass.
- 8. Check all panels for damage and missing or damaged weather stripping.
- 9. Check panic latches for proper release force.
- 10. Check panic circuit operation for operator cut off or spring return.
- 11. Clean and inspect bottom guide tracks.
- 12. Check bottom guide assembly for proper adjustment and excessive wear.
- 13. Check door closing speed and closing force.
- 14. Check closing latch location.
- 15. Check that door hold open time is 1.5 seconds or longer.
- 16. Remove access cover and check motor and gearbox for leakage and noise.
- 17. Inspect drive pulleys and belt for proper alignment.
- 18. Inspect drive belt for proper tension and excessive wear.
- 19. Clean hanger rollers and repair or replace if damaged. Adjust roller height if necessary.
- 20. Clean roller track and remove any debris. (Do not lubricate track.)
- 21. Inspect anti-riser block or rollers for damage and/or binding.
- 22. Insure that all wiring in the header is properly routed and protected from any moving components.
- 23. Reinstall and secure access cover and recheck the complete door operation.
- 24. Clean door, glass and header thoroughly.
- 25. Note on the Planned Maintenance review any recommendations to improve door performance and reliability, and review with customer.

Door Handing and Layout

Door Handing (Automatic door industry)

Sliding door handing is referenced from the exterior side of the door opening. Bi-parting sliders are not handed.

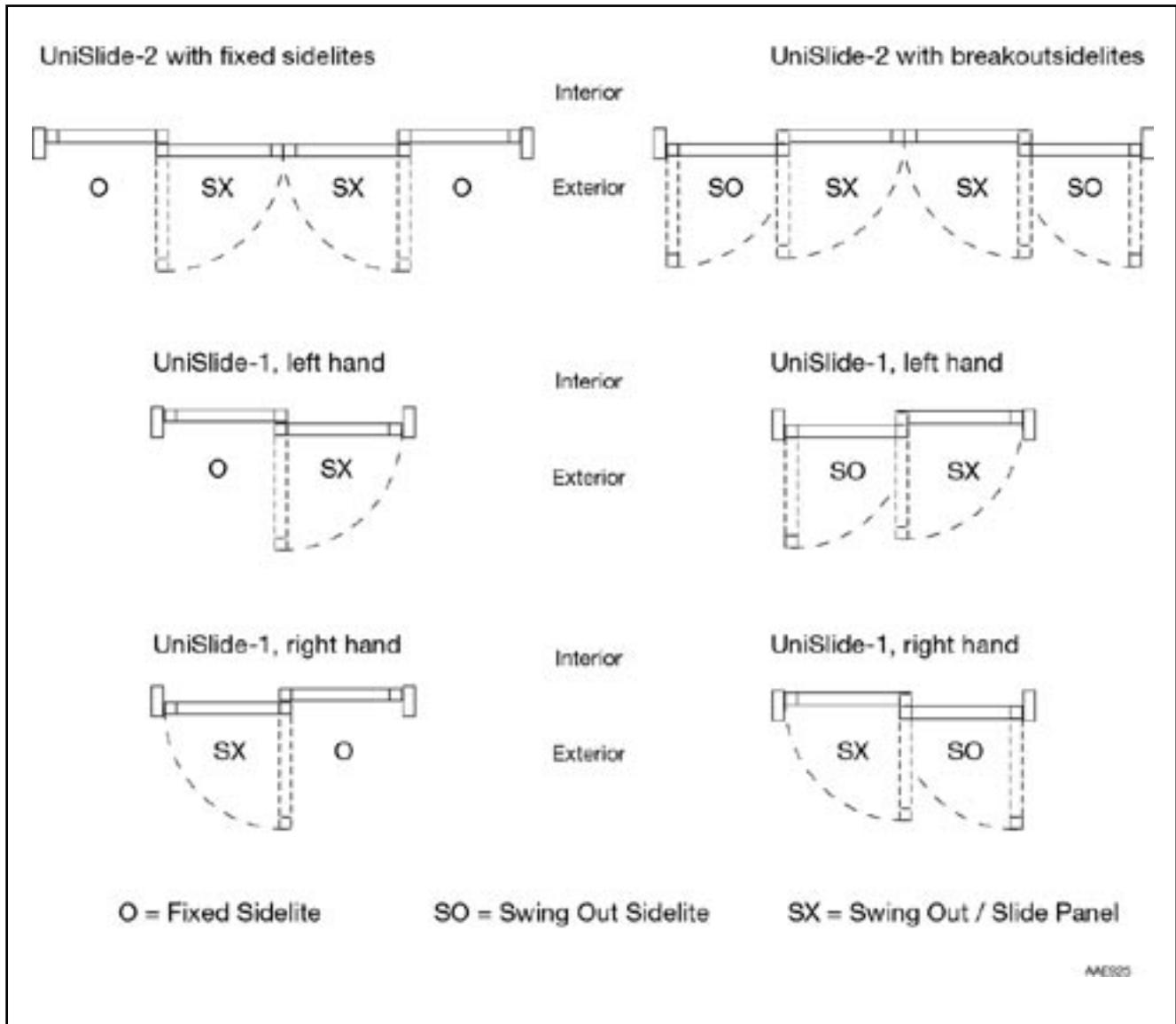



Besam Automated Entrance Systems, Inc.
1900 Airport Road
Monroe, NC 28110
Tel: (866) BESAM-US, Fax: (704) 290-5555