



## FCM-1 Control Module (IQ-318/IQ-636X-2)

### Features

- Built-in type identification automatically identifies these devices to the control unit
- Internal circuitry and relay powered directly by two-wire SLC loop; requires power for notification
- Integral LED blinks green each time a communication is received from the control unit and turns on in steady red when activated
- LED blink may be deselected globally (affects all devices)
- High noise immunity (EMF/RFI)
- Wide viewing angle of LED
- SEMS screws with clamping plates for wiring ease
- Direct-dial entry of address (01-159)
- Audible/visual applications may be wired for Class B or A (Style Y or Z)
- Face plate is made of off-white Noryl®
- Configured for a single Class B (Style Y) or Class A (Style Z) Notification Appliance Circuit
- FlashScan® communication protocol

### Applications

The FCM-1 Addressable Control Module provides the AUTOPULSE IQ-318, or IQ-636X-2 control unit a circuit for Notification Appliances (horns, strobes, speakers, etc.). Addressability allows the FCM-1 to be activated, either manually or through panel programming, on a select (zone or area of coverage) basis.

FlashScan (U.S. Patent 5,539,389) is a new communication protocol that greatly enhances the speed of communication between analog intelligent devices. Intelligent devices communicate in a grouped fashion. If one of the devices within the group has new information, the panel CPU stops the group poll and concentrates on single points. The net effect is response speed greater than five times that of other designs.

### Description

Each FCM-1 Control Module uses one of 159 possible module addresses on a SLC loop. It responds to regular polls from the control unit and reports its type and status, including the open/normal/short status of its Notification Appliance Circuit (NAC). The LED blinks with each poll received. On command, it activates its internal relay. The FCM-1 supervises Class B (Style Y) or Class A (Style Z) notification or control circuits. The FCM-1 can be used to replace the CMX-2 module, Part No. 417479, in existing systems.

Upon code command from the unit, the FCM-1 will disconnect the supervision and connect the external power supply in the proper polarity across the load device. The disconnection of the supervision provides a positive indication to the panel that the control relay actually turned ON. The external

power supply is always relay isolated from the communication loop so that a trouble condition on the external power supply will never interfere with the rest of the system.

Rotary switches set a unique address for each module. The address may be set before or after mounting. The built-in TYPE CODE (not settable) will identify the module to the control panel, so as to differentiate between a module and a sensor address.

The FCM-1 is used to switch 24 VDC audible/visual or releasing appliance power.

### Technical Information

- Normal Operating Voltage: . . . . . 15 to 32 VDC
- Maximum Current Draw: . . . . . 5.1 mA (LED on)
- Average Operating Current: . . . . . 390  $\mu$ A (LED flashing)
- Maximum NAC Current Rating:
  - Class B wiring system: . . . . . 3A
  - Class A wiring system: . . . . . 2A
- External Supply Voltage . . . . . max 80 volts (RMS or DC) between T3 and T4:
- Drain on External . . . . . 2  $\mu$ A max. (using internal EOL relay) Supply:
- EOL Resistance: . . . . . 47 K ohms
- Temperature Range: . . . . . 32 °F to 120 °F (0 °C to 49 °C)
- Humidity Range: . . . . . 10% to 93% non-condensing

### FCM-1 CONTROL MODULE

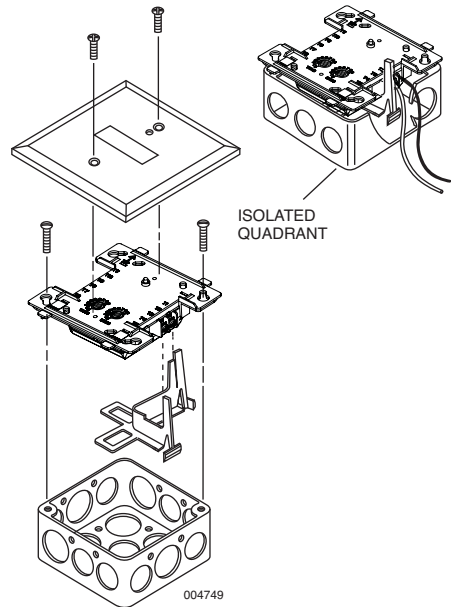

**Note:** The CB500 barrier is required by UL for separating power-limited and non-power limited wiring in the same junction box.

FCM-1 MODULE

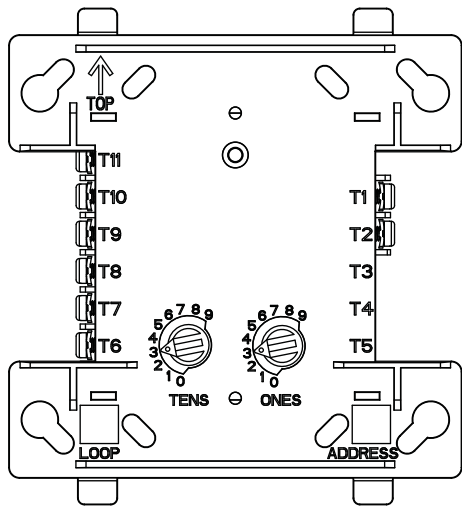

Ordering Information

Part No.	Description	Shipping Weight	
		lb	(kg)
428101	FCM-1 Intelligent Control Module	1	(0.45)
437066	FCM-1A Intelligent Control Module (ULC)	1	(0.45)
419639	Releasing Device, REL-47K	0.5	(0.23)
437071	Releasing Device, REL-47K BP (ULC)	1	(0.45)
436202	CB500 Barrier	0.5	(0.23)

Listings and Approvals\*

- UL..... S635
- ULC..... CS669
- Factory Mutual (FM)..... Approved
- California State Fire Marshal (CSFM)..... 7300-0028:202
- MEA (NYC)..... 457-99-E
- Maryland State Fire Marshal..... Permit # 2020
- USCG..... 161.002/A42/1

\* Listings and Approvals are under NOTIFIER.

TYPICAL CONNECTION OF A 24 VDC NOTIFICATION DEVICE TO THE FCM-1 MODULE

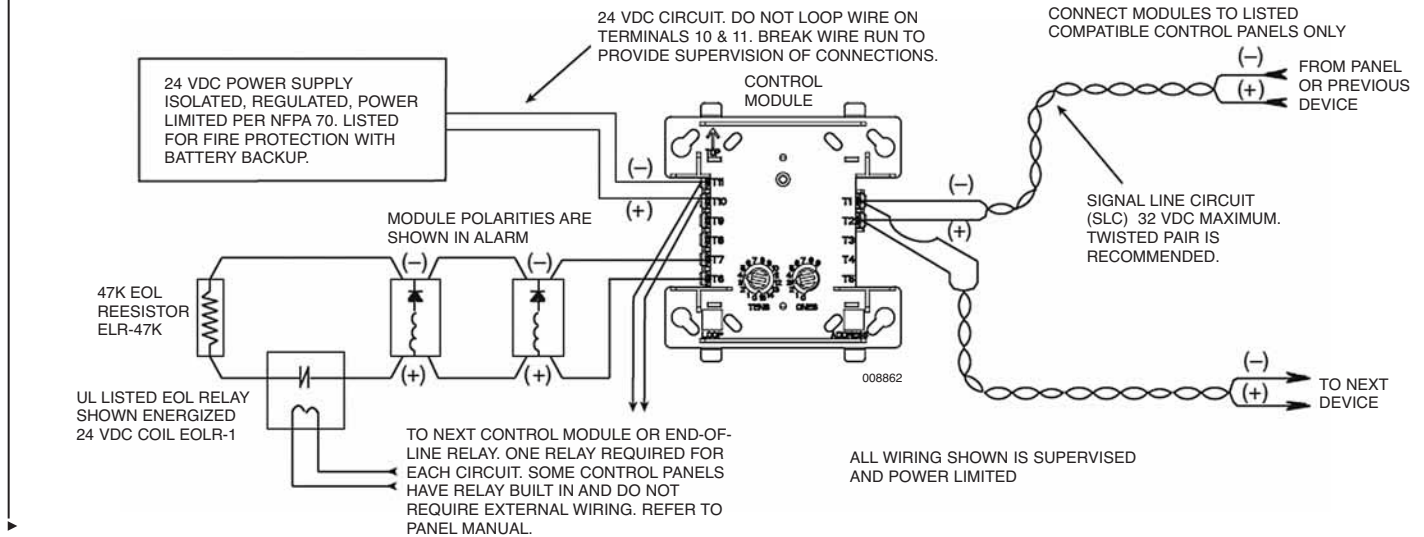

FlashScan is a trademark of Honeywell International. Noryl is a registered trademark of GE Plastics, a subsidiary of General Electric Company.



## FCM-1-REL(A) Releasing Control Module (IQ-318/IQ-636X-2)

### Features

- Redundant protocol for added protection
- Configurable for Class A or Class B operation
- External supply voltage monitoring
- Can power one 24V or two 12V solenoids
- SEMS screws for easing wiring
- Panel controlled status LED
- Analog communications
- Rotary address switches
- Low standby current
- Mounts in standard 4 in. (10.16 cm) junction box
- FlashScan® operation

### Description

The FCM-1-REL(A) Releasing Control Module is specifically designed for fire suppression releasing applications in Flash-Scan systems. Power to the release agent solenoid(s) runs through the module for full-time monitoring and supervision.

The FCM-1-REL(A) Releasing Control Module uses a redundant protocol; the module must be armed with a pair of signals in order to activate. It will then enter a 3-second window awaiting a pair of confirmation signals. If no confirmation is received, the module will automatically reset. It also supervises the wiring to the connected load and reports the status to the panel as NORMAL, OPEN, or SHORT CIRCUIT. The module has two pairs of output termination points available for fault-tolerant wiring and a panel-controlled LED indicator. The module may be connected to either one 24VDC solenoid or up to two 12VDC solenoids that are listed with the IQ-318 and IQ-636X-2 panels. To ensure proper operation, this module shall be connected to a compatible AUTOPULSE system control panel only (list available upon request). In addition, please refer to AUTOPULSE Device Compatibility Document, Part No. 50054, for the list of compatible solenoids.

**Note:** FCM-1-REL(A) is required for all new FlashScan-mode releasing applications with IQ-318 (version 12.0 or higher) and IQ-636X-2 (version 12.0 or higher) panels. Use FCM-1 for releasing applications on IQ-636X, IQ-301, and IQ-396X panels.

### Technical Information

#### GENERAL

Operating Voltage	15 to 32 VDC
Communication Line Loop Impedance	40 Ohm max.
Temperature Range	14°F to 140°F (-10° to 60°C)
Relative Humidity	10% to 95% noncondensing
Shipping Weight	5.5 oz (156 g)
Dimensions: High	4.7 in. (119 mm)
Wide	4.3 in. (109 mm)
Deep	1.4 in. (36 mm)



#### SLC

Average Operating Current . . . . . 700  $\mu$ A max @ 24 VDC  
(one communication every 5 sec. with LED enabled)

Maximum Activation Current. . . . . 9.0 mA (LED on)

#### EXTERNAL SUPPLY

Normal Operating Voltage . . . . . 24 VDC Nominal

Maximum Line Loss . . . . . 2.3 VDC (total allowable loss  
from power supply to module and  
from module to solenoid)

Minimum Operating Voltage  
to Activate Solenoid . . . . . 18 VDC (at solenoid)

Standby Current . . . . . 6.4 mA

Activation Current . . . . . 10 mA

#### SOLENOID

Supervisory Loop Voltage . . . . . 3.3 V

Supervisory Loop Current (Normal) . . . . . 30 mA

Maximum Activation Current. . . . . 2 A

#### Listings and Approvals\*

These listings and approvals apply to the modules specified in this document. In some cases, certain modules or applications may not be listed by certain approval agencies, or listings may be in process. Consult factory for latest listing status.

UL Listed . . . . . S635

ULC Listed . . . . . (FCM-1-RELA)

FM . . . . . Approved

CSFM . . . . . 7300-0028:249

\*Listings and Approvals are under NOTIFIER.

▶ TYPICAL CLASS B, SOLENOID CONFIGURATION

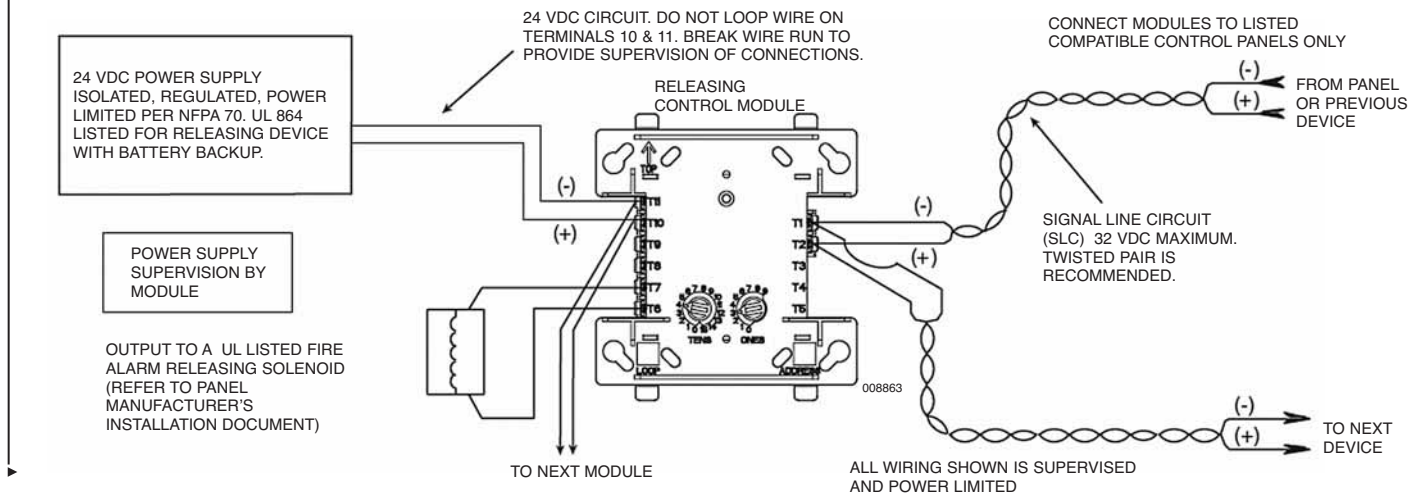

**Ordering Information**

Part No.	Description	Shipping Weight	
		lb	(kg)
436861	FCM-1-REL Releasing Control Module	1	(0.5)
436942	FCM-1-RELA Releasing Control Module (ULC Version)	1	(0.5)
436202	CB500 Control Module Barrier	0.5	(0.2)

FlashScan is a trademark of Honeywell International.

TYCO FIRE PROTECTION PRODUCTS  
ONE STANTON STREET  
MARINETTE, WI 54143-2542 715-735-7411

Copyright © 2011 Tyco Fire Protection Products  
All rights reserved.  
Form No. T-2009134-3



## FRM-1 Relay Module (IQ-318/IQ-636X-2)

### Features

- Built-in type identification automatically identifies these devices to the control unit
- Internal circuitry and relay powered directly by two-wire SLC loop
- Integral LED blinks green each time a communication is received from the control unit and turns on in steady red when activated
- LED blink may be deselected globally (affects all devices)
- High noise immunity (EMF/RFI)
- Wide viewing angle of LED
- SEMS screws with clamping plates for wiring ease
- Face plate is made of off-white Noryl®
- Controls include two rotary switches for direct-dial entry of address (01-159)
- Two Form-C dry contacts that switch together
- FlashScan® communication protocol

### Applications

The FRM-1 Addressable Relay Module provides the AUTOPULSE IQ-318 or IQ-636X-2 with dry-contact outputs for activating a variety of auxiliary devices, such as fans, dampers, control equipment, etc. Addressability allows the dry contact to be activated, either manually or through panel programming, on a select basis.

FlashScan (U.S. Patent 5,539,389) is a communication protocol that greatly enhances the speed of communication between analog intelligent devices. Intelligent devices communicate in a grouped fashion. If one of the devices within the group has new information, the unit CPU stops the group poll and concentrates on single points. The net effect is response speed greater than five times that of other designs.

### Description

Each FRM-1 module uses one of 159 possible module addresses on a SLC loop. It responds to regular polls from the control unit and reports its type and status, including the open/normal/short status of its Notification Appliance Circuit (NAC). The LED blinks with each poll received. On command, it activates its internal relay. The FRM-1 can be used to replace the CMX-2 module (Part No. 417479) in existing systems.

Rotary switches set a unique address for each module. The address may be set before or after mounting. The built-in TYPE CODE (not settable) will identify the module to the control unit, so as to differentiate between a module and a sensor address.

The FRM-1 may be programmed to operate dry contacts for door holders, Air Handling Unit shutdown, etc., and to re-set four-wire smoke detector power.

### Technical Information

Normal Operating Voltage: . . . . . 15 to 32 VDC  
 Maximum Current Draw: . . . . . 6.5 mA (LED on)  
 Average Operating Current: . . . . . 300  $\mu$ A (LED flashing)  
 EOL Resistance: . . . . . not used  
 Temperature Range: . . . . . 32 °F to 120 °F (0 °C to 49 °C)  
 Humidity Range: . . . . . 10% to 93% non-condensing

### RELAY CONTACT RATINGS

Load Description	Application	Maximum Voltage	Current Rating
Resistive	Non-Coded	30 VDC	3.0 A
Resistive	Coded	30 VDC	2.0 A
Resistive	Non-Coded	110 VDC	0.9 A
Resistive	Non-Coded	125 VAC	0.9 A
Inductive (L/R = 5 ms)	Coded	30 VDC	0.5 A
Inductive (L/R = 2 ms)	Coded	30 VDC	1.0 A
Inductive (PF = 0.35 )	Non-Coded	125 VAC	0.3 A
Inductive (PF = 0.35)	Non-Coded	25 VAC	1.5 A
Inductive (PF = 0.35)	Non-Coded	70.7 VAC	0.7 A
Inductive (PF = 0.35)	Non-Coded	25 VAC	2.0 A

**⚠ WARNING**

All relay switch contacts are shipped in the standby (open) state, but may have transferred to the activated (closed) state during shipping. The presence of high voltage may cause serious injury or death. To ensure that the switch contacts are in their correct state, modules must be made to communicate with the panel before connecting circuits controlled by the module.

### MOUNTING THE FRM-1 TO A 4 INCH SQUARE, 2 1/8 INCH DEEP JUNCTION BOX

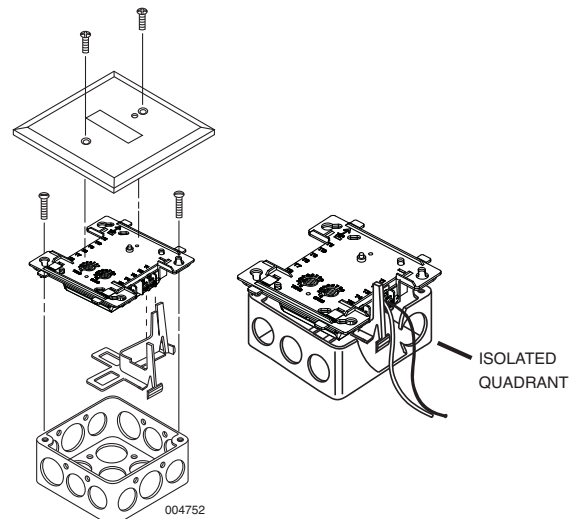



**Listings and Approvals\***

UL.....S635  
 ULC.....CS669  
 Factory Mutual (FM).....Approved  
 California State Fire Marshal (CSFM).....7300-0028:202  
 MEA (NYC).....457-99-E  
 Maryland State Fire Marshal.....Permit # 2020  
 USCG.....161.002/A42/1

\* Listings and Approvals are under NOTIFIER.

**Ordering Information**

Part No.	Description	Shipping Weight	
		lb	(kg)
428102	FRM-1 Intelligent Relay Module	1	(0.45)
437067	FRM-1A Intelligent Relay Module (ULC)	1	(0.45)
436202	CB500 Barrier	0.5	(0.23)

**WIRING DIAGRAM**

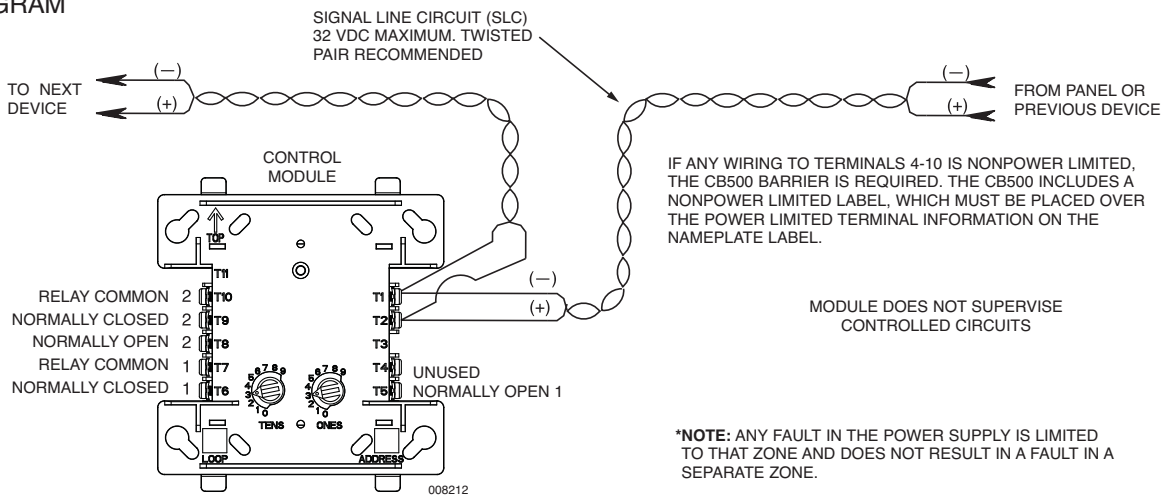

**RELAY CONTROL MODULE USED TO DISCONNECT A POWER SUPPLY**

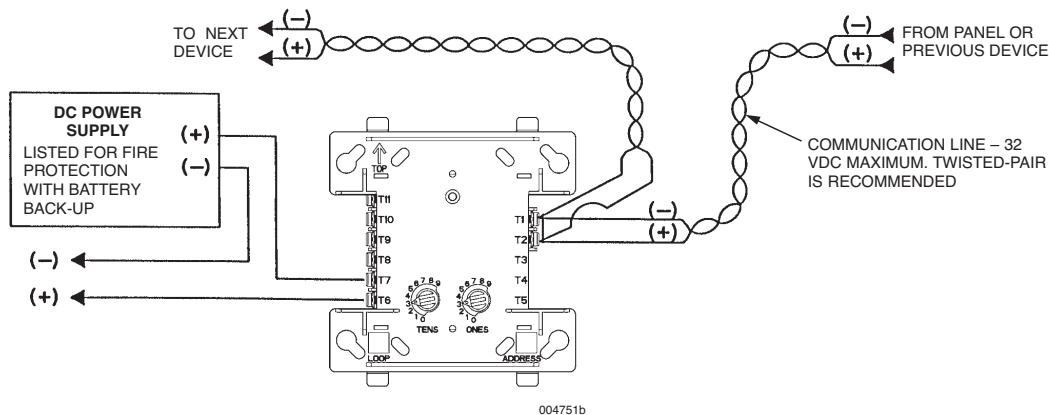

FlashScan is a trademark of Honeywell International. Noryl is a registered trademark of GE Plastics, a subsidiary of General Electric Company.



## ISO-X Fault Isolator Module (IQ-318/IQ-636X-2)

### Features

- Powered by Signaling Line Circuit (SLC) loop directly, no external power required
- Meets NFPA 72 Style 7 requirements
- Mount in standard 4 inch (102 mm) square junction box, minimum 2 1/8 inch (54 mm) deep
- Integral LED blinks to indicate normal condition; illuminates steady when short circuit condition is detected
- High noise (EMI/RFI) immunity
- Wide viewing angle of LED
- SEMS screws with clamping plates for ease of wiring
- Opens SLC loop automatically on detection of short, preventing the short from causing failure of the entire loop
- Automatically resets on correction of short

### Applications

The Fault Isolator Modules should be spaced between groups of sensors in a loop to protect the rest of the loop. It is used to isolate short circuit problems within a section of a loop so that other sections can continue to operate normally.

### Description

The ISO-X Fault Isolator Module is used with the AUTOPULSE IQ-318 and IQ-636X-2 control system to isolate short circuits on the SLC loop, so that unshorted sections of the loop can continue to operate normally. In Style 4 loops, the ISO-X is generally used at each T-tap branch to limit the effect of short circuits on a branch to the devices on that branch.

The module automatically opens a circuit when the line voltage drops below 4 volts. Fault Isolator Modules should be spaced between groups of sensors in a loop to protect the rest of the loop. If a short should occur between any two isolators, then both isolators immediately switch to an open circuit state and isolate the group of sensors between them. The remaining units on the loop continue to operate normally.

The ISO-X Fault Isolator Module automatically restores the shorted portion of the communications loop to normal condition when the short circuit condition is removed.

It mounts on a standard 4 in. (102 mm) mounting junction box which is at least 2 1/8 in. (54 mm) deep. Installation instructions are provided with each module and terminal screws are provided for “in and out” wiring.

The Fault Isolator Module (ISO-X) is used to protect critical elements of the communications loop from faults on other branches or sections of the loop. The ISO-X continuously monitors the circuit connected to terminals 3 (-) and 4 (+). Upon power-up, an integral relay is latched on.

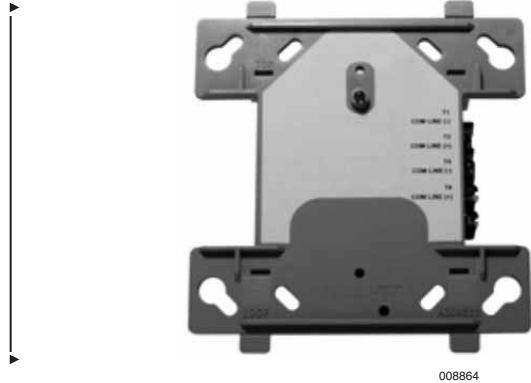

008864

The ISO-X periodically pulses the coil of this relay. A short circuit on the loop resets the relay. The ISO-X sees this short and disconnects the faulted branch by opening the positive side of the loop (terminal 4). This effectively isolates the faulted branch from the remainder of the loop. The LED indicator is on continuously during a short circuit condition. Once the fault is removed, the ISO-X automatically reapplies power to the communications loop branch.

**Note:** During a fault condition, the AUTOPULSE IQ-318 and IQ-636X-2 control system will register a trouble condition for each zone mapped to the isolated loop branch.

The face plate is made of LEXAN® with off-white color. It includes a yellow LED indicator that pulses when normal and turns on solid when a short is detected.

### Technical Information

- Operating Voltage: . . . . . 15 – 28 VDC (peak)
- Current Range: . . . . . 5 mA for LED latched in alarm
- Standby Current: . 400  $\mu$ A maximum, plus supervision current
- Temperature Range: . . . . +32 °F to +120 °F (0 °C to +49 °C)
- Relative Humidity: . . . . . 10% to 95%
- Weight: . . . . . 5 oz (150 g)

### MOUNTING THE ISO-X ISOLATOR MODULE TO A 4 INCH SQUARE, 2 1/8 INCH DEEP, JUNCTION BOX

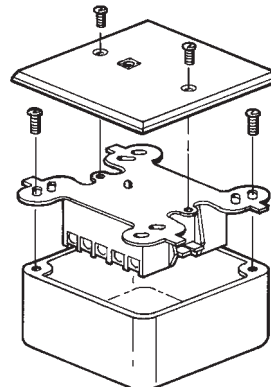

007348

**Listings and Approvals\***

UL ..... S635  
ULC ..... CS118, CS733 (ISO-XA)  
Factory Mutual (FM). .... Approved  
California State Fire Marshal (CSFM) . . . . . 7165-0028:243;  
7170-0028:244  
USCG . . . . . 161.002/A42/1  
MEA . . . . . 128-07-E

\* Listings and Approvals are under NOTIFIER

**Ordering Information**

Part No.	Description	Shipping Weight	
		lb	(kg)
417480	ISO-X Fault Isolator Module	2	(0.9)
437069	ISO-XA Fault Isolator Module (ULC)	2	(0.9)

LEXAN is a registered trademark of General Electric Corporation.





## ACS Series Annunciator Modules (IQ-318/IQ-636X-2)

### Features

- Speaker control mode for use with the AUTOPULSE IQ-318 and IQ-636X-2 panels; enables the ACS to control operation of groups of multi-channels mapped to groups of multi-speakers
- Compatible with existing annunciators
- Color-programmable LEDs
- On-board end-of-line resistors can be enabled/disabled by setting a switch
- Alarm/Circuit On and Trouble LED per point option or more dense Alarm-only option
- Touch-pad control switch option for remote control of system relays; or silence, reset, and evacuate
- LEDs may be programmed to display status of indicating circuits or control relays as well as system status conditions
- System Trouble LED indicator
- On-Line/Power LED indicator
- Alarm and trouble resound with flash of new conditions
- Local sounder for both alarm and trouble conditions with silence/acknowledge button (program options)
- May be powered by 24 VDC from the panel or by remote power supplies
- Microprocessor-controlled electronics, fully supervised
- Slip-in custom labels, lettered with standard typewriter or LabelEase program
- Plug-in terminal blocks for ease of installation and service.

### Applications

The ACS Series Annunciators provide a modular line of products for annunciation and control of the AUTOPULSE IQ-318 and IQ-636X-2 control panels, the NCA-2, and legacy addressable panels. The ACS line provides arrays of LEDs to indicate point status and, in some versions, switches to control the state of output circuits. These ACS units use a serial interface and maybe located at distances of up to 6,000 ft (1,828.8 m) from the panel.

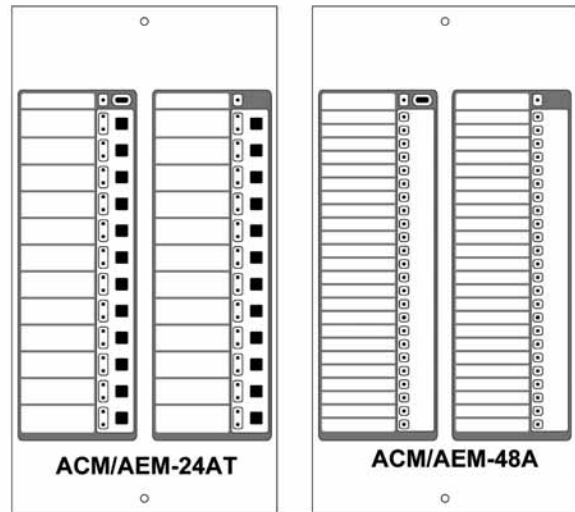

008916

### Construction

The ACS modules are provided in two basic controller modules, each with its expander module. The ACM-24AT provides 24 annunciation and control points per module, each with a red, green, or yellow Alarm/Circuit On LED, a yellow Trouble LED, and a touch-key switch. The ACM-48A provides 48 annunciation points per module, each with a red, green, or yellow Alarm/Circuit On LED (for annunciating control relays, the LED indicates ON/OFF).

On the ACM-24AT, each LED point is individually color-programmable. On ACM-48A, each column of 24 LED points can be color-configured using a DIP switch.

**Temperature and humidity ranges:** This system meets NFPA requirements for operation at 32 °F to 120 °F (0 °C to 49 °C), and at a relative humidity (non-condensing) of 85% at 86 °F (30 °C) per NFPA, and 93% ± 2% at 90 °F ± 1 °F (32 °C ± 2 °C) per ULC. However, the useful life of the system's standby batteries and the electronic components may be adversely affected by extreme temperature ranges and humidity. Therefore, it is recommended that this system and all peripherals be installed in an environment with a nominal room temperature of 60 °F to 80 °F (15 °C to 27 °C).

## ► Installation

The ACS Series annunciator and control subsystems use modular hardware assemblies which allow the custom configuration of the annunciator panel to fit the individual job requirements.

Standard back boxes and mounting hardware schemes, including special remote cabinets, allow the annunciators to be constructed and configured with other system components.

When used with the AUTOPULSE IQ-318, IQ-636X-2, or legacy panels, the ACS modules can be used for manual selection of speaker and telephone circuits. In this application, they are typically mounted in the main control near the microphone and telephone handset.

For remote annunciation applications, the modules are typically mounted in special ABF or ABS boxes. Control switch key locks (AKS-1B) are available.

Communication between the ACS Series annunciators and the host Fire Alarm Control Panel is made through an EIA-485 multi-drop loop, eliminating the need for costly wiring schemes. Four wires are required, two for the EIA-485 communications (twisted pair), and two for 24 VDC regulated power.

Retrofit of ACS Series annunciators into existing systems is easily accomplished. Software may require upgrading, and some legacy panels may require an interface board.

All field-wiring terminations use removable, compression-type terminal blocks for ease of installation, wiring, and circuit testing.

## Operation

The ACS Series annunciator and control system provides the AUTOPULSE system with up to 32 remote serially connected annunciators, each with a capacity of 96 points, for a total capacity of 3072 points (subject to the capability of the FACP). The NFS2-3030 and NCA-2 are capable of using the full 96 points.

Local or remote power supplies and serial communications allow the ACS to be located virtually anywhere on the protected premises.

On AUTOPULSE IQ-318, IQ-636X-2 and the legacy panels, system alarm and/or trouble conditions may be annunciated on a per-point basis, or in a grouped or zone configuration.

Control of system operational controls, such as Signal Silence, System Reset, and local annunciation controls (such as Local Acknowledge and Lamp Test) may be accomplished through the module's rubber keypad.

## Agency Listings and Approvals\*

► The listings and approvals below apply to the ACM/AEM-24AT and the ACM/AEM-48A. In some cases, certain modules or applications may not be listed by certain approval agencies, or listing may be in process. Consult factory for latest listing status.

- UL . . . . . S635
- ULC . . . . . S635
- • FDNY . . . . . COA #6067 (NFS2-640),  
COA #6065 (NFS2-3030)
- • CSFM. . . . . 7120-0028:0156, 7165-0028:0243,  
7165-0028:0224
- FM. . . . . Approved

\*Listings and Approvals are under NOTIFIER.

## Ordering Information

► **ACM-24AT:** The Annunciator Control Module-24AT contains 24 color-programmable (red/green/yellow) Active and 24 yellow Trouble LEDs, 24 momentary touch-pad switches, a System Trouble LED, an On-Line/Power LED, and a local piezo sounder with a silence/acknowledge switch for audible indication of alarm and trouble conditions. Includes instructions. The ACM-24AT is 8.375 in. (213 mm) high x 4.375 in. (111 mm) wide.

**AEM-24AT:** The Annunciator Expander Module-24AT expands the ACM-24AT by 24 system points. The AEM-24AT is identical in size and in frontal appearance to the ACM-24AT. Up to three of these expander modules can be supported by an ACM-24AT, for a maximum of 96 system points. The AEM-24AT is 8.375 in. (213 mm) high x 4.375 in. (111 mm) wide.

**Note:** The AEM-24AT cannot be used to expand the ACM-48A.

**ACM-48A:** The Annunciator Control Module-48A contains 48 color-programmable (red/green/yellow) Active LEDs, a System Trouble LED, an On-Line/Power LED, and a local piezo sounder with a Silence/Acknowledge switch for audible indication of alarm and trouble conditions. Includes instructions. The ACM-48A is 8.375 in. (213 mm) high x 4.375 in. (111 mm) wide.

**AEM-48A:** The Annunciator Expander Module-48A expands the ACM-48A by 48 system points. The AEM-48A is identical in frontal appearance to the ACM-48A. One expander module can be supported by an ACM-48A, providing a maximum of 96 points (subject to the capability of the FACP). The AEM-48A is 8.375 in. (213 mm) high x 4.375 in. (111 mm) wide.

**Note:** The AEM-48A cannot be used to expand the ACM-24AT.

**ABS-1TB:** The ABS-1TB is an attractive black surface-mount back box for mounting one ACS Series Annunciator. Unlike the ABS-1B, the ABS-1TB has an increased depth that allows mounting of the AKS-1B Annunciator Key Switch. The ABS-1TB is 9.938 in. (252 mm) high x 4.625 in. (117 mm) wide x 2.5 in. (64 mm) deep.

► **Note:** An earlier gray model ABS-1TB will not accommodate the ACM/AEM-24AT or ACM/AEM-48A. The slightly deeper ABS-1TB will accommodate both the ACM/AEM-24AT or ACM/AEM-48A models.

## Ordering Information (Continued)

► **ABF-1B:** The Annunciator Flush Box-1B (black) provides for the remote mounting of a single annunciator module in a flush-mount enclosure. Knockouts are provided for use with 1/2 in. (13 mm) conduit. The ABF-1B includes a painted black metal trim plate (11 in. (279 mm) high x 6.25 in. (159 mm) wide), mounting hardware, and an adhesive-backed annunciator label for the dress plate. The ABF-1B is 9.938 in. (252 mm) high x 4.625 in. (117 mm) wide x 2.5 in. (64 mm) deep.

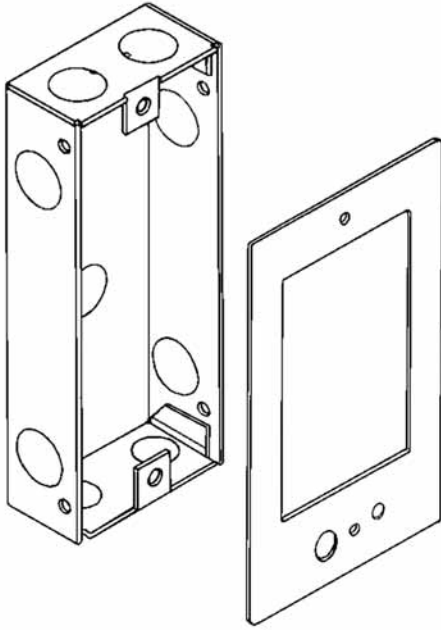

008917

**ADP-4B:** The Annunciator Dress Panel-4B (black) provides for the cabinet mounting of one to four modules. The ADP-4B hinge-mounts to the CAB-4 Series cabinet. Modules mount directly to threaded studs on the dress panel.

**DP-DISP2:** Dress Panel accommodates up to two annunciator modules (no expanders).

**BMP-1:** Annunciator Blank Module is a flat black dress plate that covers unused module positions in the annunciator back box or in the ADP-4B. The BMP-1 is 8.375 in. (213 mm) high x 4.375 in. (111 mm) wide. Studs for a variety of module mounting options are available.

**AKS-1B:** The Annunciator Key Switch-1B (black) provides access security for the control switches on the ACM/AEM-24AT. The key switch kit includes a key and hardware for mounting to the ABF-1B. Also included is an adhesive-backed annunciator label for use with the key switch/dress plate assembly.

► **Note:** The AKS-1B can only be employed with the ABS-1TB.

Part No.	Description	Shipping Weight	
		lb	(kg)
432787	ACM-24AT, Annunciator Control Module, 24 Zone Alarm/Trouble	2	(0.9)
432790	AEM-24AT, Annunciator Expander Module, 24 Zone Alarm	2	(0.9)
432788	ACM-48A, Annunciator Control Module, 48 Zone Alarm/Trouble	2	(0.9)
432791	AEM-48A, Annunciator Expander Module, 48 Zone Alarm	2	(0.9)
417493	ABS-1TB, Annunciator Back Box, Surface, Single, Deep	1	(0.5)
417657	ABF-1B, Annunciator Back Box, Flush, Single	1	(0.5)
433520	ADP-4B, Annunciator Dress Panel	2	(0.9)
433614	DP-DISP2, Dress Panel	2	(0.9)
432794	BMP-1, Annunciator Blank Module	2	(0.9)
417660	AKS-1B, Annunciator Key Switch	1	(0.5)





## ACM-8R Relay Module (IQ-318/IQ-636X-2)

### Features

- Provides eight Form-C relays with 5-amp contacts
- The relays can be employed to track any group of 8 software zones in the AUTOPULSE IQ-301 control system or track a variety of devices and panel points, in a group fashion, on the IQ-318 or IQ-636X-2
- Removable terminal blocks for ease of installation and service
- DIP switch selectable memory mapping of relays
- Compatible with AUTOPULSE IQ-318 and IQ-636X-2 control units

### Applications

The ACM-8R is a module in the ACS class of annunciators and will mount to an ABS-8RB annunciator surface-mount back box with blank faceplate. It provides the AUTOPULSE IQ-318 or IQ-636X-2 control system with a mappable relay control module. The relays on this module can be selected for mapping anywhere in the AUTOPULSE IQ-318 or IQ-636X-2 (by groups of eight) control system memory map.

### Description

Communication between the control unit and the ACM-8R is accomplished over a two-wire EIA-485 serial interface. This communication, to include the wiring, is supervised by the AUTOPULSE control system. Power for the annunciators is provided via a separate power loop from the control unit which is inherently supervised (loss of power also results in a communication failure at the control unit). Up to 32 annunciators may be installed on an EIA-485 circuit.

- ▶ **ABS-8RB BACK BOX:** 9 15/16 IN. x 4 5/8 IN. x 2 1/2 IN. DEEP (252 mm x 117 mm x 64 mm DEEP)

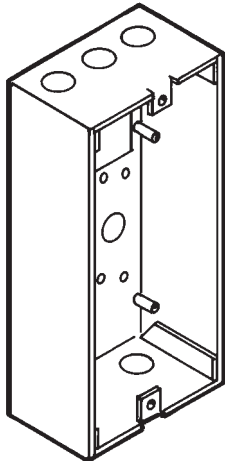

007252

### RELAY TERMINAL ASSIGNMENTS

THE ACM-8R PROVIDES EIGHT RELAYS WITH FORM-C CONTACTS RATED FOR 5 AMPS. THE TERMINAL ASSIGNMENTS ARE ILLUSTRATED BELOW.

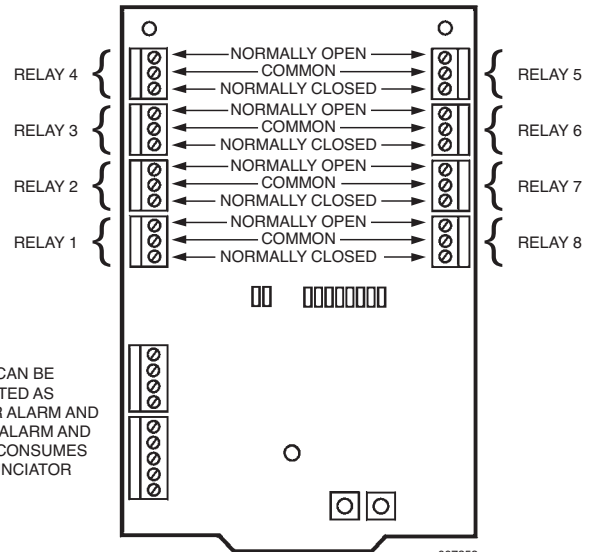

CIRCUITS CAN BE ANNUNCIATED AS ALARM, OR ALARM AND TROUBLE. ALARM AND TROUBLE CONSUMES TWO ANNUNCIATOR POINTS.

007253

### THE ACM-8R RELAY MODULE

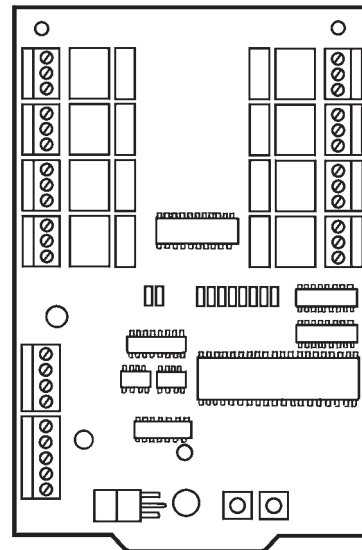

007254

## Technical Information

Voltage: . . . . . 24 VDC

Standby Current: . . . . . 30 mA

Maximum Current (all relays activated): . . . . . 158 mA

### Data Communications

Port: . . . . . EIA-485 operating at 20 K baud

### Relay Contact Rating

Resistive: . . . . . 5 amps @ 125 VAC or 30 VDC

Inductive: . . . . . 2 amps @ 125 VAC

**Note:** Form-C gold-plated, silver alloy relay contacts are for medium duty switching and are not intended for motor control or pilot duty.

## Listings and Approvals\*

UL . . . . . S635

ULC . . . . . CS635 Vol. 1

MEA (NYC) . . . . . 128-07-E Vol. 5\*\*

Factory Mutual (FM) . . . . . Approved

California State Fire Marshal (CSFM) . . . . . 7120-0028: 156

\*Listings and Approvals are under NOTIFIER.

▶ \*\*Listing under Tyco Fire Protection Products.

## Ordering Information

Part No.	Description	Shipping Weight	
		lb	(kg)
417653	ACM-8R, Annunciator Control Module with 8 Relays	2	(0.9)
▶ 436996	ABS-8RB, Surface Back Box	1	(0.5)



# Detection and Control Components



## XP10-M Ten-Input Monitor Module (IQ-318/IQ-636X-2)

### Features

- Ten addressable Class B or five addressable Class A initiating device circuits
- Removable 12 AWG (3.25 mm<sup>2</sup>) to 18 AWG (0.9 mm<sup>2</sup>) plug-in terminal blocks
- Status indicators for each point
- Panel-Controlled Green LED Indicators
- Unused addresses may be disabled
- Rotary address switches
- Class A or Class B operation
- FlashScan® or CLIP operation
- Mount one or two modules in a BB-XP cabinet (optional)
- Mount up to six modules on a CHS-6 chassis in a CAB-3 Series or BB-25 cabinet (optional)
- Mounting hardware included

### Description

The XP10-M ten-input monitor module provides an interface between the addressable AUTOPULSE IQ-318 and IQ-636X-2 control units and normally open contact devices, such as pull stations, heat detectors, or flow switches.

The first address on the XP10-M is set from 01 to 150 and the remaining modules are automatically assigned to the next nine higher addresses. Provisions are included for disabling a maximum of two unused addresses.

The supervised state (normal, open, or short) of the monitored device is sent back to the panel. A common SLC input is used for all modules, and the initiating device loops share a common supervisory supply and ground – otherwise each monitor operates independently from the others. Each XP10-M module has panel-controlled green LED indicators.

FlashScan (U.S. Patent 5,539,389) is a communication protocol that greatly enhances the speed of communication between analog intelligent devices. Intelligent devices communicate in a grouped fashion. If one of the devices within the group has new information, the unit's CPU stops the group poll and concentrates on single points. The net effect is response speed **greater than five times** that of earlier designs.

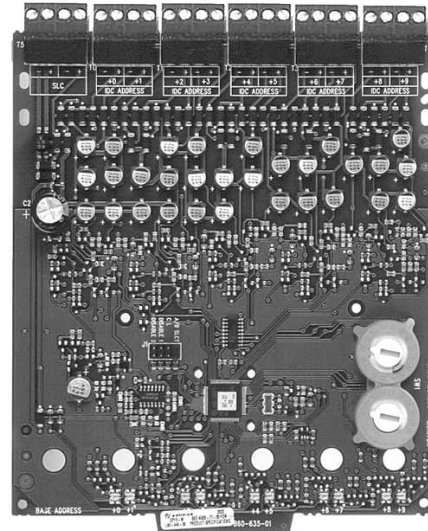

007000

### Technical Information

Standby Current:	3.5 mA (SLC current draw with all addresses used; if some addresses are disabled, the standby current decreases.)
Alarm Current:	55 mA (assumes all ten LEDs solid ON)
Temperature Range:	32 °F to 120 °F (0 °C to 49 °C) for UL applications; 14 °F to 131 °F (-10 °C to 55 °C) for EN54 applications
Humidity Range:	10% to 85% noncondensing for UL applications; 10% to 93% noncondensing for EN54 applications
Dimensions:	
Height:	6.8 in. (172.7 mm)
Width:	5.8 in. (147.3 mm)
Depth:	1.25 in. (31.75 mm)
Wire Gauge:	12 AWG (3.25 mm <sup>2</sup> ) to 18 AWG (0.9 mm <sup>2</sup> )
Maximum SLC Wiring Resistance:	40 or 50 ohms, panel dependent
Maximum IDC Wiring Resistance:	40 ohms
Maximum IDC Voltage:	12 VDC
Maximum IDC Current:	1 mA

**Installation**

Power-limited circuits must employ type FPL, FPLR, or FPLP cable as required by Article 760 of the NEC. The XP10-M is shipped in Class B position. Remove shunt for Class A operation. Up to six XP10-M modules can be mounted on a CHS-6 chassis, which mounts in a BB-25, CAB 3 or 4, or suitably grounded metallic cabinet. One or two modules can be mounted in a BB-XP cabinet. Mounting hardware and installation instructions are provided with each module.

**Wiring**

Each XP10-M module comes with removable 12 AWG (3.25 mm<sup>2</sup>) to 18 AWG (0.9 mm<sup>2</sup>) plug-in terminal blocks.

**Typical Initiating Device Circuit Configuration – Class B, Style B.**

**Note:** Any number of UL-Listed contact closure devices may be used. **DO NOT MIX** fire alarm initiating and supervisory devices on the same initiating device circuit. Install contact closure devices per manufacturer’s installation instructions.

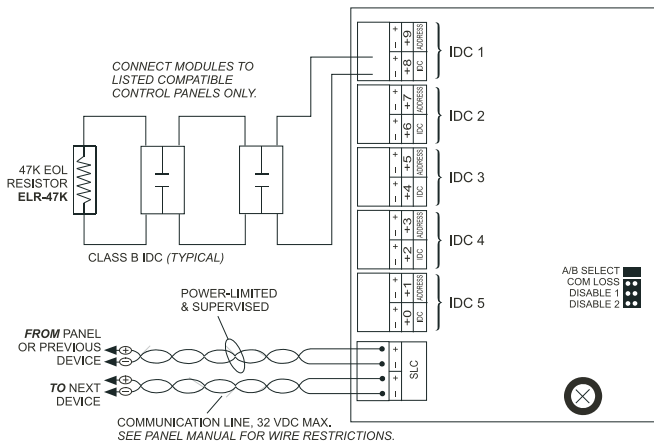

007001

**Typical Fault-Tolerant Initiating Device Circuit Configuration – Class A, Style D.**

**Note:** Any number of UL-Listed contact closure devices may be used. **DO NOT MIX** fire alarm initiating and supervisory devices on the same initiating device circuit. Install contact closure devices per manufacturer’s installation instructions.

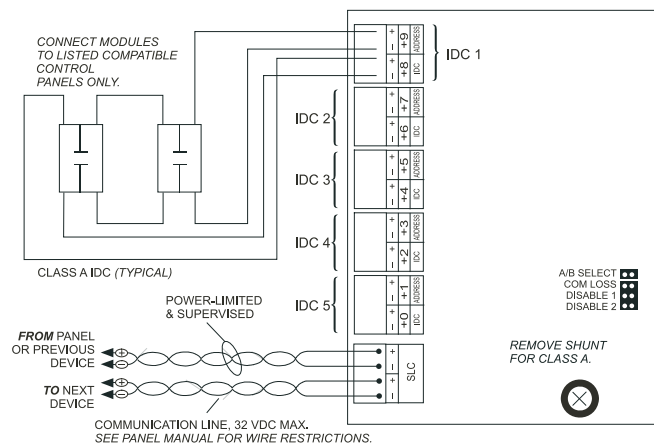

007002

**Listings and Approvals\***

UL .....	S635
Factory Mutual (FM).....	Approved
California State Fire Marshal (CSFM) .....	7300-0028:219
MEA (NYC) .....	43-02-E
Maryland State Fire Marshal .....	Permit #2106
USCG.....	161.002/A42/1

\* Listings and Approvals are under NOTIFIER.

**Ordering Information**

Part No.	Description	Shipping Weight	
		lb	(kg)
432714	XP10-M Ten-input Monitor Module (UL)	1.1	(0.5)
428078	BB-XP Cabinet for One or Two Modules	7	(3.2)
428079	BB-25 Cabinet	15	(6.8)
428080	CHS-6 Chassis	2	(0.9)

**CHS-6 CHASSIS**

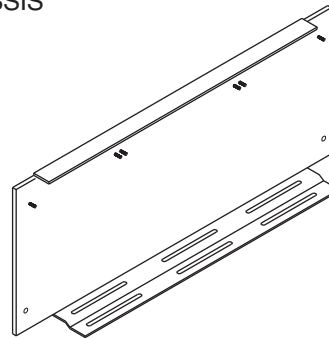

004754

19 IN. WIDE X 7 5/16 IN. HIGH X 2 3/16 IN. DEEP (483 mm wide x 186 mm high x 56 mm deep)

**BACK-BOX/CABINET**

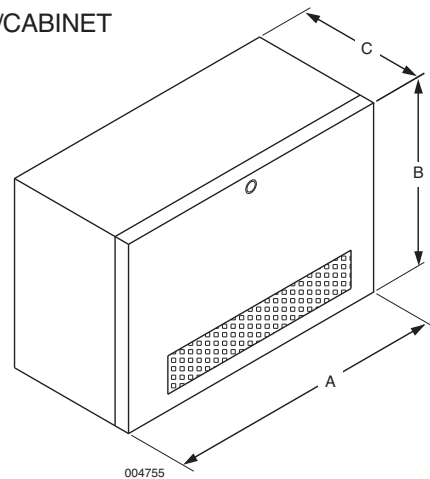

004755

	Dimensions		
	A – Width	B – Height	C – Depth
BB-25 Battery Back Box	24 in (610 mm)	12 5/8 in (321 mm)	5 1/4 in (133 mm)
BB-XP Cabinet	9 1/2 in (241 mm)	12 1/2 in (318 mm)	3 in (76 mm)

FlashScan is a registered trademark of Honeywell International.



(Page Left Intentionally Blank)





## XP6-R Six-Relay Control Module (IQ-318/IQ-636X-2)

### Features

- Six addressable Form-C relay contacts
- Removable 12 AWG (3.25 mm<sup>2</sup>) to 18 AWG (0.9 mm<sup>2</sup>) plug-in terminal blocks
- Status indicators for each point
- Panel-Controlled Green LED Indicators
- Unused addresses may be disabled
- Rotary address switches
- FlashScan® or CLIP operation
- Mount one or two modules in a BB-XP cabinet (optional)
- Mount up to six modules on a CHS-6 chassis in a CAB-3 Series or BB-25 cabinet (optional)
- Mounting hardware included

### Description

The XP6-R six-relay control module provides the addressable AUTOPULSE IQ-318 and IQ-636X-2 control units with six Form-C relays. The first module is addressed from 01 to 154 while the remaining modules are automatically assigned to the next five higher addresses. Provisions are included for disabling a maximum of three unused modules. A single isolated set of dry relay contacts is provided for each module address, which is capable of being wired for either a normally-open or normally-closed operation. The module allows the control panel to switch these contacts on command. No supervision is provided for the controlled circuit. Each XP6-R module has panel-controlled green LED indicators.

FlashScan® (U.S. Patent 5,539,389) is a communication protocol that greatly enhances the speed of communication between analog intelligent devices. Intelligent devices communicate in a grouped fashion. If one of the devices within the group has new information, the unit's CPU stops the group poll and concentrates on single points. The net effect is response speed **greater than five times** that of earlier designs.

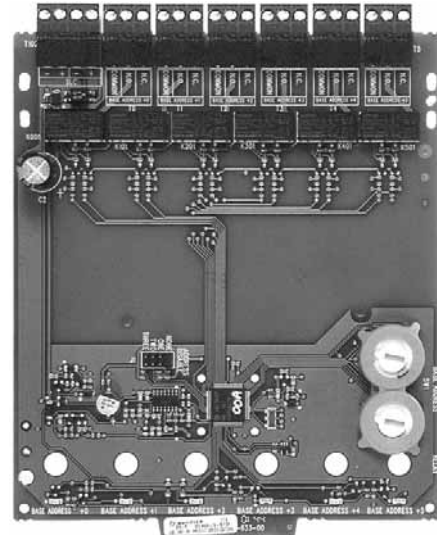

007003

### Technical Information

Standby Current:	1.45 mA (SLC current draw with all addresses used; if some addresses are disabled, the standby current decreases.)
Alarm Current:	32 mA (assumes all six relays have been switched once and all six LEDs solid ON)
Temperature Range:	32 °F to 120 °F (0 °C to 49 °C)
Humidity Range:	10% to 85% noncondensing
Dimensions: Height:	6.8 in. (172.7 mm)
Width:	5.8 in. (147.3 mm)
Depth:	1.0 in. (25.4 mm)
Wire Gauge:	12 AWG (3.25 mm <sup>2</sup> ) to 18 AWG (0.9 mm <sup>2</sup> )
Maximum SLC Wiring Resistance:	40 or 50 ohms, panel dependent
Relay Current:	30 mA/relay pulse (15.6 ms pulse duration), pulse under panel control
Relay Contact Ratings:	30 VDC; 125 VAC
Current Ratings:	<ul style="list-style-type: none"> <li>3.0 A @ 30 VDC maximum, resistive, non-coded</li> <li>2.0 A @ 30 VDC maximum, resistive, coded</li> <li>1.0 A @ 30 VDC maximum, inductive (L/R=2 ms), coded</li> <li>0.5 A @ 30 VDC maximum, inductive (L/R=5 ms), coded</li> <li>0.9 A @ 110 VDC maximum, resistive, non-coded</li> <li>0.9 A @ 125 VAC maximum, resistive, non-coded</li> <li>0.7 A @ 70.7 VAC maximum, inductive (PF=0.35), non-coded</li> <li>0.5 A @ 125 VAC maximum, inductive (PF=0.35), non-coded</li> </ul>

**Installation**

Up to six XP6-R modules can be mounted on a CHS-6 chassis, which mounts in a BB-25, CAB-A3, CAB 3 or 4 series cabinet. One or two modules can be mounted in BB-XP cabinet. Mounting hardware and installation instructions are provided with each module.

**Wiring**

Each XP6-R module comes with removable 12 AWG (3.25 mm<sup>2</sup>) to 18 AWG (0.9 mm<sup>2</sup>) plug-in terminal blocks.

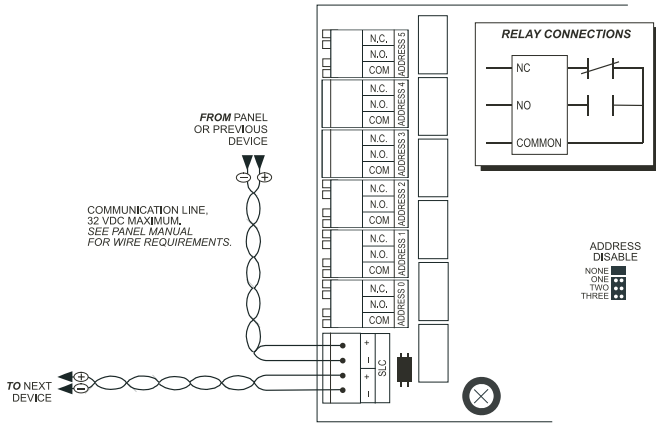

007004

**Listings and Approvals\***

- UL . . . . . S635
- ULC . . . . . CS118 (XP6-RA)
- Factory Mutual (FM) . . . . . Approved
- California State Fire Marshal (CSFM) . . . . . 7300-0028:219
- MEA (NYC) . . . . . 368-01-E
- Maryland State Fire Marshal . . . . . Permit #2099
- USCG . . . . . 161.002/A42/1

\*Listings and Approvals are under NOTIFIER.

**Ordering Information**

Part No.	Description	Shipping Weight	
		lb	(kg)
432716	XP6-R Six-relay Control Module (UL)	1.1	(0.5)
428078	BB-XP Cabinet for One or Two Modules	7	(3.2)
428079	BB-25 Cabinet	15	(6.8)
428080	CHS-6 Chassis	2	(0.9)

**CHS-6 CHASSIS**

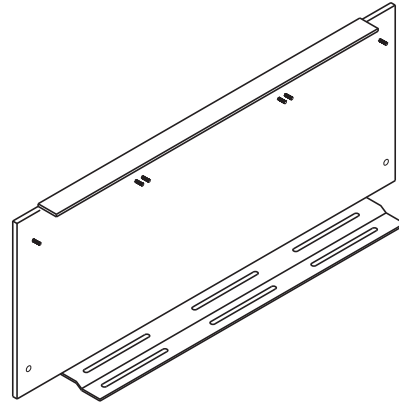

19 IN. WIDE X 7 5/16 IN. HIGH X 2 3/16 IN. DEEP  
(483 mm wide x 186 mm high x 56 mm deep)

004754

**BACK-BOX/CABINET**

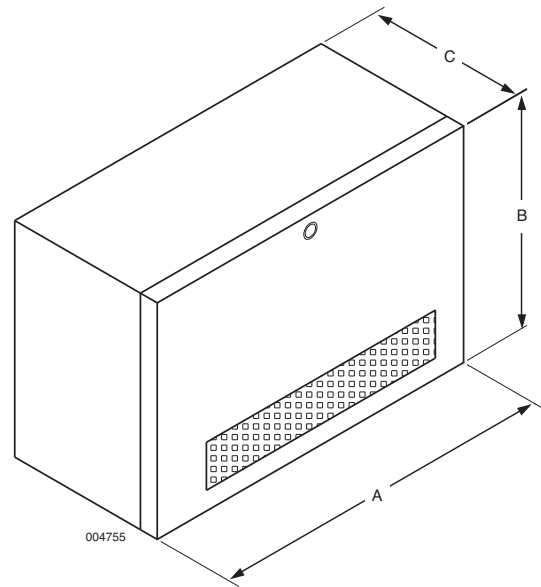

004755

	Dimensions		
	A – Width	B – Height	C – Depth
BB-25 Battery Back Box	24 in (610 mm)	12 5/8 in (321 mm)	5 1/4 in (133 mm)
BB-XP Cabinet	9 1/2 in (241 mm)	12 1/2 in (318 mm)	3 in (76 mm)

FlashScan is a registered trademark of Honeywell International.





## FDM-1 Addressable Dual Monitor Module (IQ-318/IQ-636X-2)

### Features

- Built-in type identification automatically identifies this device as a monitor module to the AUTOPULSE control unit
- Powered directly by two-wire SLC loop, no additional power required
- High noise (EMF/RFI) immunity
- SEMS screws with clamping plates for ease of wiring
- Direct-dial entry of address (01-159)
- LED flashes green during normal operation (this is a programmable option), and latches on steady RED to indicate alarm
- FlashScan® communication protocol
- Compatible with IQ-318 and IQ-636X-2

### Applications

Use the FDM-1 module to monitor two zones of four-wire smoke detectors, manual fire alarm pull stations, waterflow devices, or other normally-open dry-contact alarm activation devices. May also be used to monitor normally-open supervisory devices with special supervisory indication at the control unit. Monitored circuit may be wired as an NFPA Style B only. A 47K ohm End-of-Line Resistor (provided) terminates the Style B circuit. The FDM-1 does not support Style D (Class A) initiating device circuits. Maximum IDC loop resistance is 1500 ohms.

### Description

The FDM-1 is a standard-sized dual monitor module used to monitor and supervise two independent two-wire initiating device circuits (IDCs) at two separate, consecutive addresses in intelligent, two-wire systems.

Each FDM-1 uses two consecutive addresses of the 159\* available module addresses on an SLC loop. It responds to regular polls from the control unit and reports its type and the status (open/normal/short) of its IDC. A green flashing LED indicates that the module is in communication with the control unit. The LED latches on steady red to indicate alarm (subject to current limitations on the loop).

FlashScan (U.S. Patent 5,539,389) is a communication protocol that greatly enhances the speed of communication between analog intelligent devices. Intelligent devices communicate in a grouped fashion. If one of the devices within the group has new information, the unit's CPU stops the group poll and concentrates on single points. The net effect is response speed **greater than five times** that of earlier designs.

The FDM-1 automatically assigns itself to two addressable points, starting with the original address. For example, if the FDM-1 is set to address "56," then it will automatically assign itself to addresses "56" and "57." **Note:** "ones" addresses on the FDM-1 are 0, 2, 4, 6, or 8 only. Terminals 6 and 7 use the first address, and terminals 8 and 9 use the second address.

---

### NOTICE

---

Avoid duplicating addresses on the system.

---

### Technical Information

Nominal Operating Voltage: . . . . . 15 to 32 VDC  
Maximum Current Draw: . . . . . 5.7 mA (LED on)  
Maximum IDC Resistance: . . . . . 1500 ohms  
Average Operating Current: . . . . . 750  $\mu$ A (LED flashing)  
EOL Resistance: . . . . . 47K ohms  
Temperature Range: . . . . . 32 °F to 120 °F ( 0 °C to 49 °C)  
Humidity Range: . . . . . 10% to 93% non-condensing  
Dimensions:  
Height: . . . . . 4.5 in. (114 mm)  
Width: . . . . . 4 in. (102 mm)  
Depth: . . . . . 2.125 in. (54 mm)

### Installation

The FDM-1 module mounts directly to a standard 4 in. square, 2.124 in. (54 mm) deep, electrical box. Mounting hardware and installation instructions are provided with each module. All wiring must conform to applicable local codes, ordinances, and regulations. These modules are intended for power-limited wiring only.

- ▶ MOUNTING THE FDM-1 TO A 4 IN. (102 mm) SQUARE
- ▶ 2 1/8 IN. (54 mm) DEEP JUNCTION BOX

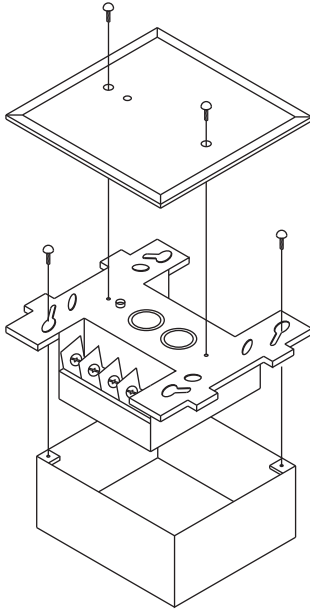

### Wiring

- Connect modules to listed compatible AUTOPULSE control units only.
- All wiring shown is supervised and power limited.
- Install contact closure devices per manufacturers' installation instructions.
- Any number of UL-listed contact closure devices may be used.
- **DO NOT MIX** fire alarm initiating, supervisory, or security devices on the same circuit.

### Listings and Approvals\*

UL.....	S635
ULC.....	CS669
Factory Mutual (FM).....	Approved
California State Fire Marshal (CSFM).....	7300-0028:202
MEA (NYC).....	143-01-E
USCG.....	161.002/A42/1

\* Listings and Approvals are under NOTIFIER.

### Ordering Information

Part No.	Description	Shipping Weight	
		lb	(kg)
432294	FDM-1 Monitor Module	1	(0.45)

004745

DETAIL OF FDM-1 – NOTE “ONES” ADDRESSES ARE 0, 2, 4, 6, 8 ONLY

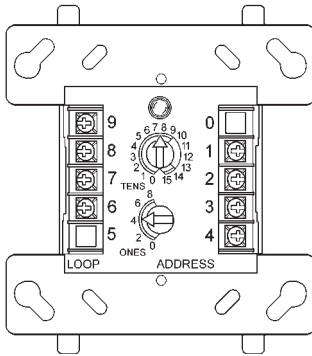

006882

### TYPICAL DUAL TWO-WIRE STYLE B INITIATING DEVICE CIRCUIT CONFIGURATION

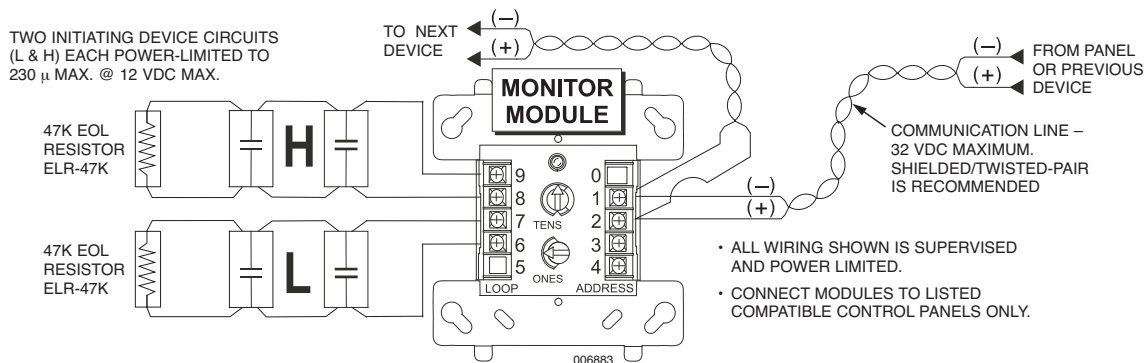

006883

FlashScan is a registered trademark of Honeywell International.

TYCO FIRE PROTECTION PRODUCTS  
 ONE STANTON STREET  
 MARINETTE, WI 54143-2542 715-735-7411

Copyright © 2011 Tyco Fire Protection Products  
 All rights reserved.  
 Form No. T-2007105-3



## FMM-101 Monitor Module (IQ-318/IQ-636X-2)

### Features

- Built-in type identification automatically identifies this device as a monitor module to the AUTOPULSE control unit
- Powered directly by two-wire FACP, no additional power required
- High noise (EMF/RFI) immunity
- Tinned, stripped leads for ease of wiring
- Direct-dial entry of address (01-159)
- FlashScan™ communication protocol

### Applications

Use the FMM-101 module to monitor a single device or a zone of four-wire smoke detectors, manual fire alarm pull stations, waterflow devices, or other normally-open dry-contact devices. May also be used to monitor normally-open supervisory devices with special supervisory indication at the AUTOPULSE IQ-318 or IQ-636X-2 control unit. Monitored circuit/device is wired as an NFPA Style B (Class B) Initiating Device Circuit. A 47K ohm End-of-Line Resistor (provided) terminates the circuit.

The FMM-101 monitor module can be installed in a single-gang junction directly behind the monitored unit. Its small size and lightweight allow it to be installed without rigid mounting. The FMM-101 is intended for use in intelligent, two-wire systems where the individual address of each module is selected using rotary switches. It provides a two-wire initiating device circuit for normally-open-contact fire alarm and security devices.

### Description

The FMM-101 is a miniature monitor module used to supervise a Class B (Style B) circuit. Its compact design allows the FMM-101 to often be mounted in a single-gang box behind the device it is monitoring. The FMM-101 can be used to replace MMX-101 module (Part No. 417478) in existing systems.

Each FMM-101 uses one of 159 available module addresses on an SLC loop. It responds to regular polls from the control panel and reports its type and the status (open/normal/short) of its Initiating Device Circuit (IDC).

FlashScan (patent pending) is a new communication protocol that greatly enhances the speed of communication between analog intelligent devices. Intelligent devices communicate in a grouped fashion. If one of the devices within the group has new information, the unit's CPU stops the group poll and concentrates on single points. The net effect is response speed **greater than five times** that of earlier designs.

FlashScan is a trademark of NOTIFIER.

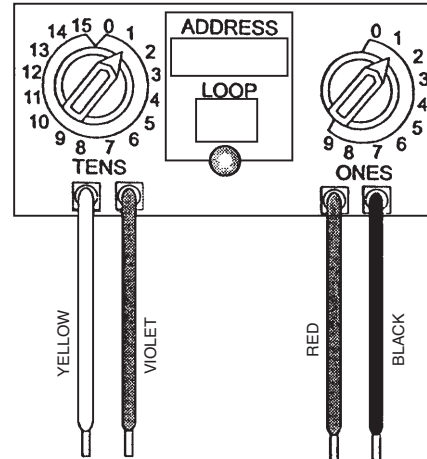

### Technical Information

004757

- Nominal Operating Voltage: . . . . . 15 to 32 VDC
- Average Operating Current: . . . . . 350  $\mu$ A (maximum)
- EOL Resistance: . . . . . 47K ohms
- Temperature Range: . . . . . 32 °F to 120 °F (0 °C to 49 °C)
- Humidity Range: . . . . . 10% to 93% non-condensing
- Wiring Length: . . . . . 6 in. (152 mm) minimum
- Dimensions:
  - High: . . . . . 1.3 in. (33 mm)
  - Wide: . . . . . 2.75 in. (70 mm)
  - Deep: . . . . . 0.5 in. (13 mm)

### Installation

The FMM-101 module should be wired and mounted without rigid connections inside a standard electrical box. All wiring must conform to applicable local codes, ordinances, and regulations.

### Listings and Approvals\*

- UL . . . . . S635
- ULC . . . . . CS699
- Factory Mutual (FM) . . . . . Approved
- California State Fire Marshal (CSFM) . . . . . 7300-0028:202
- MEA . . . . . 128-07-E
- Maryland State Fire Marshal . . . . . Permit #2020
- USCG . . . . . 161.002/A42/1

\* Listings and Approvals are under NOTIFIER

### Ordering Information

Part No.	Description	Shipping Weight	
		lb	(kg)
428098	FMM-101 Monitor Module	1	(0.45)
437065	FMM-101A Monitor Module (ULC)	1	(0.45)





## LDM Series Lamp Driver Modules (IQ-318/IQ-636X-2)

### Features

- ALARM and TROUBLE Lamp/LED per point (IQ-318 and IQ-636X-2) or per software zone, or more dense ALARM-only option (field selectable)
- System trouble Lamp/LED signal
- On-line/power LED indicator
- Alarm and trouble resound with flash of new conditions
- Local sounder for both alarm and trouble conditions with silence/acknowledge switch connection
- Serial EIA-485 interface for reduced installation cost
- May be powered by 24 VDC from the unit or by remote power supplies
- Efficient switched power converter reduces power consumption
- Fully supervised microprocessor-controlled electronics
- Plug-in terminal blocks for ease of installation and service
- Trouble monitor option for remote power supplies

### Applications

The LDM series lamp driver modules, when combined with a custom graphic display, provide annunciation and control for the AUTOPULSE IQ-318 or IQ-636X-2 control system. These modules use a serial communications interface and may be located up to 6,000 ft (1829 m) from the unit.

The LDM-32/LDM-E32 with a custom graphic array may be used to indicate point or software zone status. In addition, the LDM-R32 module which connects to any LDM-32 or LDM-E32 converts transistor outputs to 32 Form-A dry contacts for electrical isolation when interfacing the system to other equipment.

### Description

Two basic models are available: the LDM-32 control module and the LDM-E32 expander module. Each may be selected to provide 32 alarm indications or 16 alarm and 16 trouble. Both modules mount on four standoffs inside the custom annunciator graphic box. Alternately, the modules may be installed in a CHS-4L chassis. The CHS-4L chassis may be mounted to the graphic annunciator cabinet to provide installation of up to four LDM-32 or LDM-E32 modules.

The LDM-32 includes a system trouble lamp driver and lamp test/local acknowledge switch input. Integral piezo sounder sounds for each new alarm or trouble and is silenced with the Local Acknowledge switch, or permanently disabled with a dip-switch selection. Flash of new alarms or trouble is selectable through dip switches. Switch inputs may be used for panel Silence or Reset. Instructions are included.

One LDM-E32 is allowed per LDM-32 in alarm-only mode. Three LDM-E32 modules are allowed per LDM-32 in alarm/trouble mode. The LDM-E32 includes expander ribbon cable.

The LDM-R32 provides 32 Form-A dry contacts (1 amp @ 30 VDC) output terminal screw connections. It is mounted on an LDM-32 or an LDM-E32. A separate common is provided for each group of 8 relays. Ribbon cables to connect to the LDM-32/LDM-E32 are included.

The LDM-CBL24 and LDM-CBL48 ribbon cable sets can be ordered to provide either a 24 in. (610 mm) or 48 in. (1219 mm) connection between LDM-32/LDM-E32 and LEDs or lamps on a custom graphic unit. They each include all cables necessary for one LDM-32 or LDM-E32. Cables have a connector on one end only (split, strip, and connect other end to graphic annunciator).

Communications between the LDM series annunciators and the host AUTOPULSE control system are made through a two-wire EIA-485 multi-drop loop, and a two-wire regulated 24 VDC power loop. Up to 32 LDM systems may be connected to a single control unit, providing redundant annunciators if required. All field wiring terminations use removable, compression-type terminal blocks for ease of installation, wiring, and circuit testing.

The LDM series modules, when used with a custom graphic annunciator, provide the AUTOPULSE IQ-318 control system with up to 32 unique or redundant annunciators indicating the status of the 99 software zones. When used with the IQ-636X-2, the LDM series modules provide the system with up to 32 unique or redundant annunciators, each with a capacity of 64 points for a total capacity of 2048 points. Local or remote power supplies and serial communications allow the custom annunciators to be located virtually anywhere on the protected premises. Management of system operational controls, such as signal silence and system reset, may be accomplished through special key or push switches.

### LDM-32 CONTROL MODULE

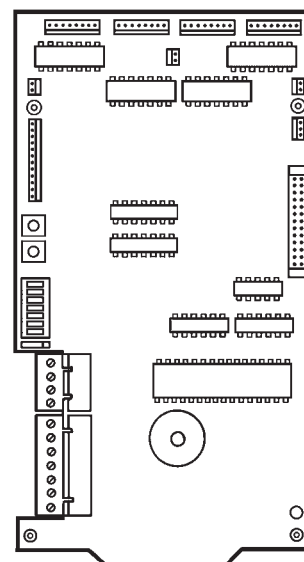

007255

## Description (Continued)

### LDM-E32 EXPANDER MODULE

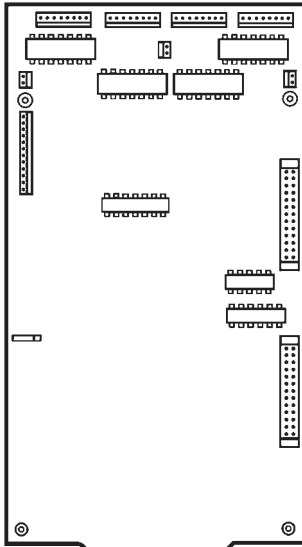

007256

### LDM-R32 RELAY EXPANDER MODULE

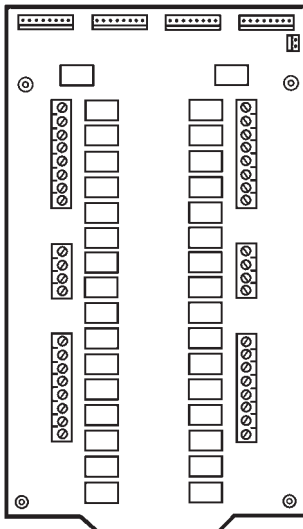

007257

### CHS-4L CHASSIS

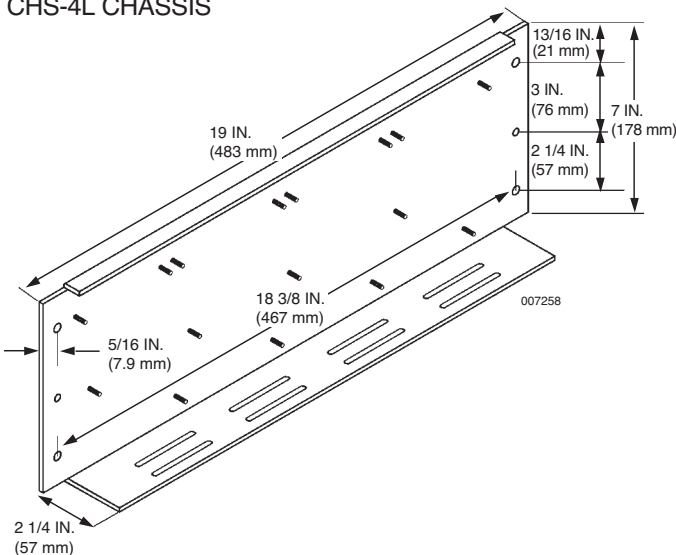

## Technical Information

Size: . . . . . 4.4 in. x 7.1 in. (112 mm x 181 mm)

LDM-32 and LDM-E32

Output Driver: . . . . . Bipolar Darlington Open Collector NPN transistor

Maximum Current/Output: . . . . . 100 mA (external current limit)

Voltage Rating on Output Driver: . . . . . 30 VDC (either 24 VDC or 5 VDC)

LED: . . . . . High efficiency 2 mA

LED Resistor (5 VDC): . . . . . 680 Ω, 1/4 W (each LED)

LED Resistor (24 VDC): . . . . . 10K Ω, 1/4 W (each LED)

Switch Rating: . . . . . 5 VDC @ 0.5 mA

Standby Current

LDM-32: . . . . . 40 mA

LDM-E32: . . . . . 2 mA

Alarm Current

LDM-32: . . . . . 56 mA

LDM-E32: . . . . . 18 mA

LDM-R32: . . . . . 288 mA

Relay Contacts – LDM-R32: . . . . . 1 amp @ 30 VDC resistive, gold clad silver alloy

## Listings and Approvals\*

UL . . . . . S635

ULC . . . . . CS100

MEA (NYC) . . . . . 17-96-E, 317-01-E

Factory Mutual (FM) . . . . . Approved

California State Fire Marshal (CSFM) . . . . . 7120-0028: 156

\* Listings and Approvals are under NOTIFIER.

## Ordering Information

Part No.	Description	Shipping Weight	
		lb	(kg)
417501	LDM-32, Lamp Driver Annunciator Control Module	1	(0.5)
417502	LDM-E32, Lamp Driver Annunciator Expander Module	1	(0.5)
417650	LDM-R32, Lamp Driver Relay Module	1	(0.5)
417651	LDM-CBL24, Lamp Driver Annunciator Cable, 24 in. (610 mm)	0.5	(0.3)
417652	LDM-CBL48, Lamp Driver Annunciator Cable, 48 in. (1219 mm)	0.5	(0.3)
418576	CHS-4L, Chassis, Low Profile, For Up To 4 LDM Modules	1	(0.5)
437052	CHS-4L, Chassis, Low Profile (ULC)	1	(0.5)



# Detection and Control Components



## FCPS-24S6 and FCPS-24S8 6-Amp and 8-Amp 24-Volt Remote Power Supplies (IQ-318/IQ-636X-2)

### General

The FCPS-24S6 (6-amp) and FCPS-24S8 (8-amp) are compact, cost-effective remote power supplies with battery charger. The FCPS-24S6/-24S8 may be connected to any 12- or 24-volt Fire Alarm Control Panel (FACP) or may be used as a stand-alone supply. Primary applications include Notification Appliance (bell) Circuit (NAC) expansion (to support ADA requirements and NAC synchronization) or auxiliary power to support 24-volt system accessories. The FCPS-24S6/-24S8 provides regulated and filtered 24 VDC power to four notification appliance circuits configured as either four Class B (Style Y) or Class A (Style Z, with ZNAC-4 option module). Alternately, the four outputs may be configured as all non-resettable, all resettable, or two non-resettable and two resettable. The FCPS-24S6/-24S8 also contains a battery charger capable of charging up to 18 AH batteries.

### Features

- UL-Listed NAC synchronization using System Sensor, Wheelock, or Gentex “Commander2” appliances.
- Cascadable for up to ten power supplies (four for Gentex) with strobe timing maintained.
- Operates as a “sync follower” or as a “sync generator” (default). See Note on page 2.
- Contains two fully-isolated input/control circuits – triggered from FACP NAC (NAC expander mode) or jumpered permanently “ON” (stand-alone mode).
- Four Class B (Style Y) or four Class A (Style Z, with ZNAC-4 module) NACs.
- 6-amp (FCPS-24S6) or 8-amp (FCPS-24S8) full load output, with 3 amps maximum/circuit, in NAC expander mode (UL 864).
- 4-amp (FCPS-24S6) or 6-amp (FCPS-24S8) continuous output in stand-alone mode (UL 1481).
- Compatible with coded inputs; signals passed through.
- Optional power-supervision relay (EOLR-1).
- In stand-alone mode, output power circuits may be configured as: resettable (reset line from FACP required), nonresettable, or a mix of two and two.
- Fully regulated and filtered power output – optimal for powering four-wire smoke detectors, annunciators, and other system peripherals requiring regulated/filtered power.
- Power-limiting technology meets UL power-limiting requirements.
- Form-C normally-closed trouble relay.
- Fully supervised power supply, battery, and NACs.
- Selectable earth fault detection.
- AC trouble report selectable for immediate or 8-hour delay.

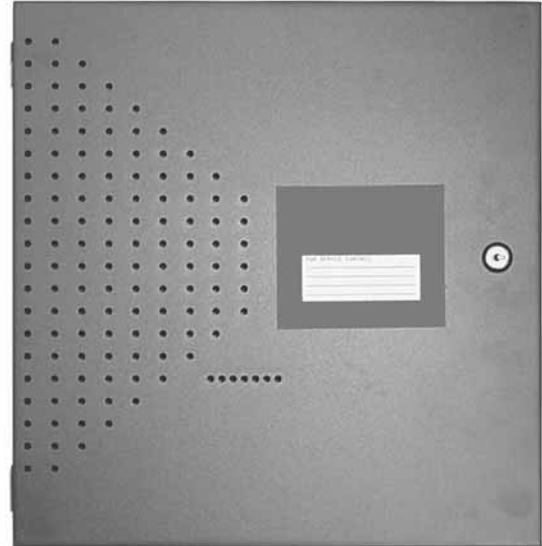

007281

- Works with virtually any UL 864 fire alarm control which utilizes an industry-standard reverse-polarity notification circuit (including unfiltered and unregulated bell power).
- Requires input trigger voltage of 9.0 – 32 VDC.
- Self-contained in compact, locking cabinet – 15 in. (381 mm) high x 14.5 in. (368 mm) wide x 2.75 in. (70 mm) deep.
- Includes integral battery charger capable of charging up to 18 AH batteries. Cabinet capable of housing 7.0 AH batteries.
- Battery charger may be disabled via DIP switch for applications requiring larger batteries.
- Fixed, clamp-type terminal blocks accommodate up to 12 AWG (3.1 mm<sup>2</sup>) wire.

### Standards and Codes

The FCPS-24S6/-24S8 complies with the following standards:

- NFPA 72 National Fire Alarm Code.
- UL 864 Standard for Control Units for Fire Alarm Systems (NAC expander mode).
- UL 1481 Power Supplies for Fire Alarm Systems (stand-alone mode).

### Specifications

#### Primary (AC) power:

- FCPS-24S6/-24S8: 120 VAC, 60 Hz, 3.2 A maximum.
- Wire size: minimum #14 AWG (2.0 mm<sup>2</sup>) with 600 V insulation.

**Control input circuit:**

- Trigger input voltage: 9 to 32 VDC.
- Trigger current: 2.0 mA (16 – 32 V). Per input: 1.0 mA (9–16 V).

Trouble contact rating: 5 amps at 24 VDC.

Auxiliary power output: specific application power 500 mA maximum.

**Output circuits:**

- +24 VDC filtered, regulated.
- 3.0 amps maximum for any one circuit.
- Total continuous current for all outputs (stand-alone mode): for FCPS-24S6: 4.0 amps maximum; for FCPS-24S8: 6.0 amps maximum.
- Total short-term current for all outputs (NAC expander mode): for FCPS-24S6: 6.0 amps maximum; for FCPS-24S8: 8.0 amps maximum.

**Secondary power (battery) charging circuit:**

- Supports lead-acid batteries only.
- Float-charge voltage: 27.6 VDC.
- Maximum charge current: 1.5 amps
- Maximum battery capacity: 18 AH.

**Applications**

Example 1: Expand notification appliance power an additional 6.0 amps (FCPS-24S6) or 8.0 amps (FCPS-24S8). Use up to four Class B (Style Y) outputs or four Class A (Style Z) outputs (using ZNAC-4). For example, the FACP notification appliance circuits will activate the FCPS when reverse-polarity activation occurs. Trouble conditions on the FCPS are sensed by the FACP through the notification appliance circuit.

Example 2: Use the FCPS to expand auxiliary regulated 24-volt system power up to 4.0 amps (FCPS-24S6) or up to 6.0 amps (FCPS-24S8). Both resettable and non-resettable power options are available. Resettable outputs are created by connecting the resettable output from the FACP to one or both of the FCPS inputs.

Example 3: Use addressable control modules to activate the FCPS instead of activating it through the FACP notification appliance circuits. This typically allows for mounting the FCPS at greater distances\* away from the FACP while expanding system architecture in various applications.

For example, an addressable control module is used to activate the FCPS, and an addressable monitor module is used to sense FCPS trouble conditions. Local auxiliary power output from the FCPS provides power to the addressable control module.

**Sync Follower/Generator Note**

In some installations, it is necessary to synchronize the flash timing of all strobes in the system for ADA compliance. Strobes accomplish this by monitoring very short timing pulses on the NAC power which are created by the FACP. When installed at the end of a NAC wire run, the FCPS-24S6/-24S8 can track (i.e., “follow”) the strobe synchronization timing pulses on the existing NAC wire run. This maintains the overall system flash timing of the additional strobes attached to the FCPS.

When the FCPS-24S6/-24S8 is configured (via DIP switch settings) as a “sync follower,” the FCPS’s NAC outputs track the strobe synchronization pulses present at the FCPS’s sync input terminal. The pulses originate from an upstream FACP or other power supply.

When the FCPS-24S6/-24S8 is configured (via DIP switch settings) as a “sync generator,” the FCPS’s sync input terminals are not used. Rather, the FCPS is the originator of the strobe synchronization pulses on the FCPS’s NAC outputs. In “sync generator” mode, the sync type (System Sensor, Wheelock, or Gentex) is selectable via DIP switch settings.

**Product Line Information**

**FCPS-24S6:** 6.0 amp, 120 VAC remote charger power supply. Includes main printed circuit board, transformers, enclosure (15 in. (381 mm) high x 14.5 in. (368 mm) wide x 2.75 in. (70 mm) deep), and installation instructions (Part No. 433594).

**FCPS-24S8:** 8.0 amp, 120 VAC remote charger power supply. Includes main printed circuit board, transformers, enclosure (15 in. (381 mm) high x 14.5 in. (368 mm) wide x 2.75 in. (70 mm) deep), and installation instructions (Part No. 433595).

**EOLR-1:** 12/24 VDC end-of-line relay for monitoring four-wire smoke detector power.

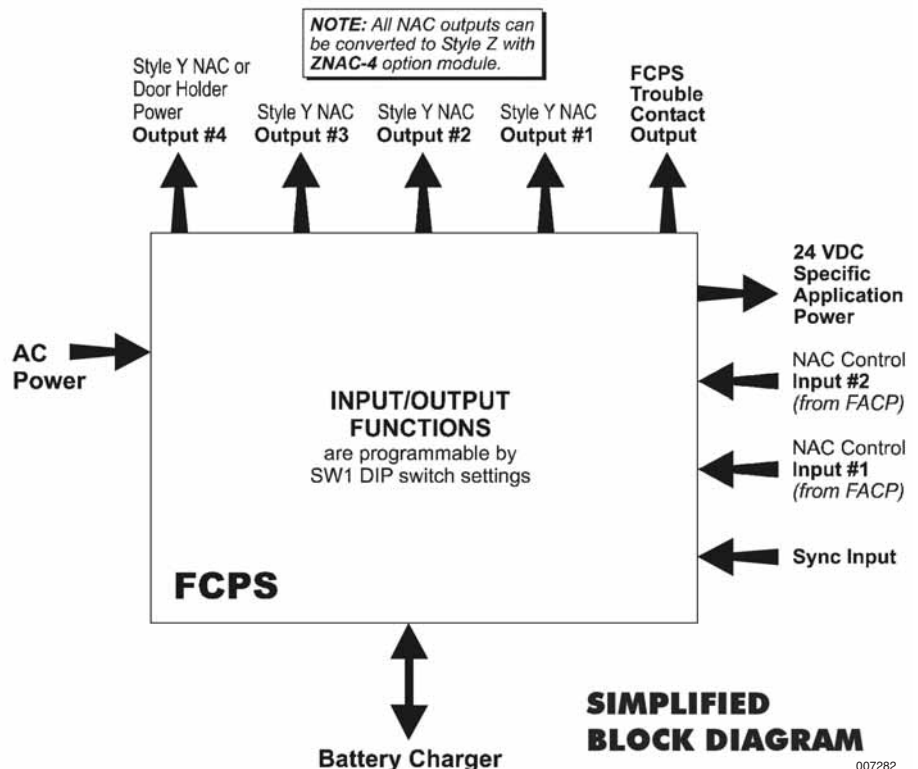

## Agency Listings and Approvals\*

UL Listed ..... S635  
 U.S. Coast Guard..... 161.002/A42/1  
 California State Fire Marshal..... 7315-0028:225  
 Factory Mutual (FM)..... Approved  
 MEA (NYC) ..... 299-02-E

\*Listings and Approvals are under NOTIFIER.

## BOARD LAYOUT

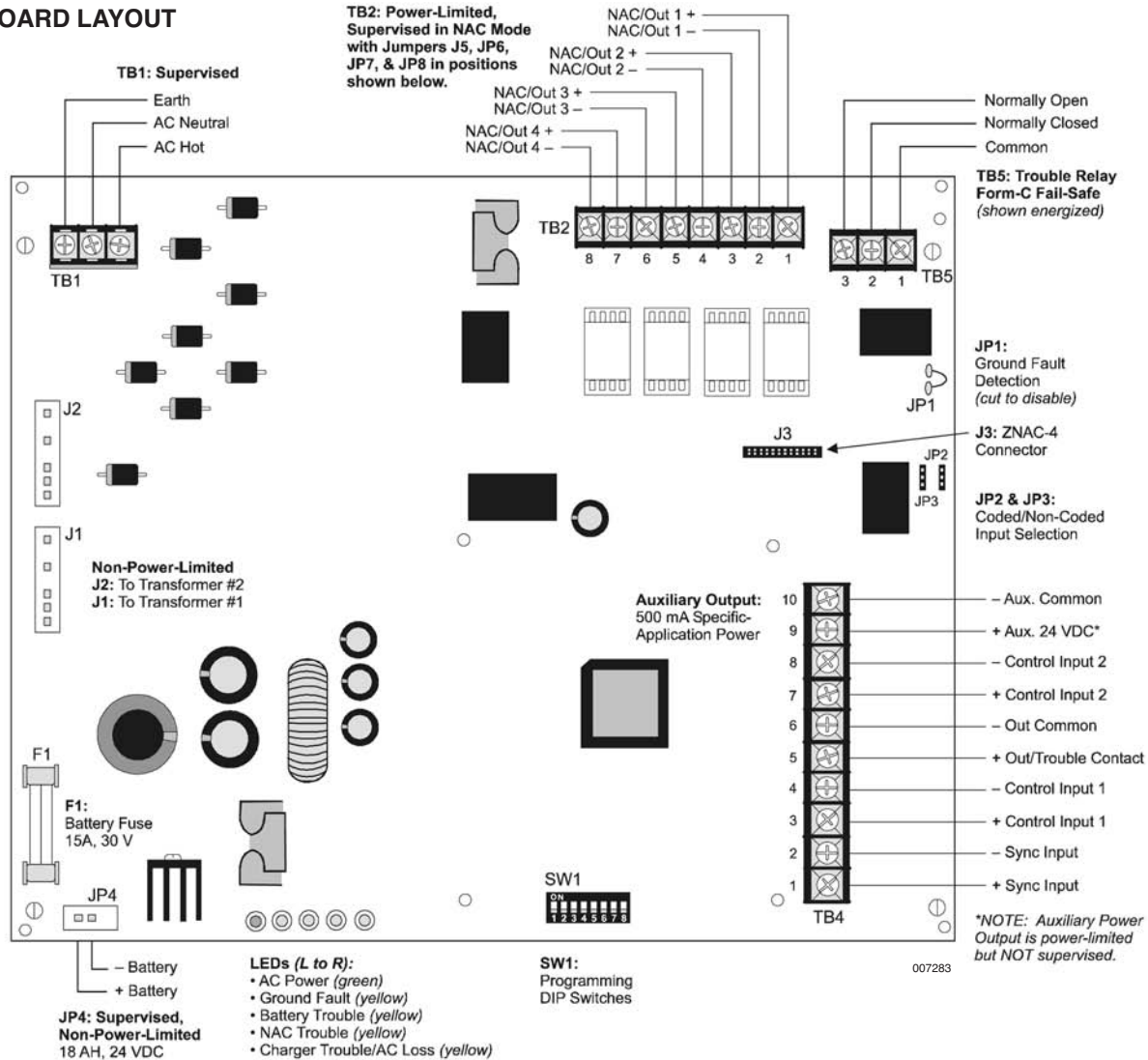

## Ordering Information

Part No.	Description	Shipping Weight	
		lb	(kg)
433594	FCPS-24S6 24-Volt Remote Power Supply	18	(8.2)
433595	FCPS-24S8 24-Volt Remote Power Supply	18	(8.2)





## ACPS-610 Addressable Charger/ Power Supply (IQ-318/IQ-636X-2)

### General

The ACPS-610 is an auxiliary power supply with a battery charging option and a host of special features. Selectable charging options allow the ACPS-610 to provide 6 amps of power to four outputs while charging batteries from 12 to 200 AH, or 10 amps of power when the unit is configured for use with an external battery charger. Four individually addressable outputs can be independently configured for auxiliary power or Notification Appliance Circuits (NAC). NAC outputs support notification appliance synchronization for devices manufactured by System Sensor®, Wheelock, and Gentex. An option to disable battery charging allows the system designer to use the four built-in circuits to distribute 10 amps of power for general purposes, excluding NAC applications.

The ACPS-610 is compatible with the AUTOPULSE IQ-318/IQ-636X-2 fire suppression control panels using CLIP and FlashScan® protocol.

### Features

- Listed to UL Standard 864, 9th Edition.
- Provides 6.0 A of NAC power or 10 A of general purpose power.
- Four Class B (Style Y) or four Class A (Style Z) outputs, individually addressable by the FACP.
- When built-in outputs are configured for NAC operation, each circuit supports strobe synchronization with the following manufacturers' audio/visual devices: System Sensor (SpectrAlert® and SpectrAlert Advance Series) or Wheelock or Gentex.
- Each circuit can be software-selected for use as: a Notification Appliance Circuit, general purpose 24 VDC power, four-wire detector power, or door holder.
- Steady, March Time (120 PPM), Two Stage, Temporal, or UZC Zone-Coded and Non-Coded devices – software-selectable by circuit.
- Universal Zone Coder (UZC-256) option supports for programmable coded outputs. Up to 256 different codes.
- Charges 12 to 200 AH batteries with full supervision. The charger on the ACPS may be disabled via software. When disabled, a separate, external charger is required, for example, a CHG-120.
- May be used to provide battery backup for multiple ACPS supplies.
- AC loss detection, brownout detection, and AC loss delay reporting.
- Power-limited outputs.
- Isolated Signaling Line Circuit (SLC) interface.
- Selectable ground fault detection.
- Canadian two stage operation.

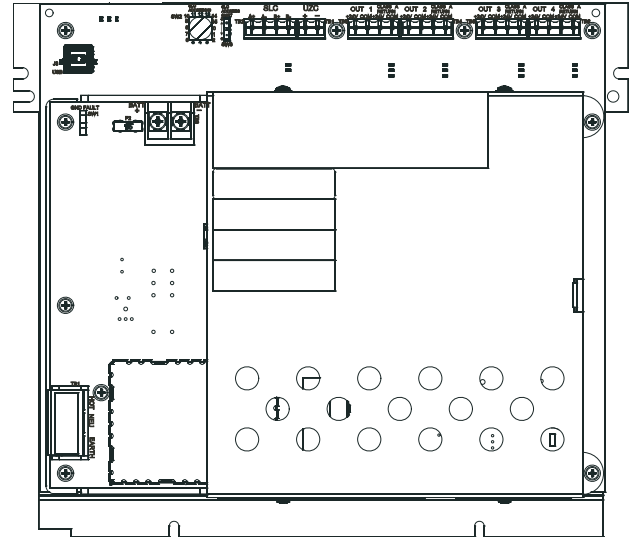

### Installation Standards

The ACPS-610 complies with the following standards:

- NFPA 70 and NFPA 72 National Fire Alarm Code
- Underwriters Laboratories UL 864, 9th Edition, Standard for Control Units for Fire Alarm Systems and CAN/ULC – S527-99.

In addition, the installer should be familiar with the following standards:

- NEC Article 760 Fire Protective Signaling Systems
- Applicable Local and State Building Codes
- Requirements of the Local Authority Having Jurisdiction

### Specifications

- Primary (AC) power:
  - ACPS-610: 120 VAC, 50/60 Hz input, 5.0 A maximum
- Output voltage: 24 VDC electrically regulated and power/limited (under primary AC mains). Under secondary power, 20.4 to 26.4 VDC.
- Output circuits – TB3, TB4, TB5, TB6 on Main Board: 1.5 A maximum for any NAC output circuit. 2.5 A maximum for any Power output with battery charger disabled.
- Secondary power (battery) charging circuit – TB3 on KAPS-24 Board: lead-acid battery charger which will charge 12 to 200 AH batteries. Maximum charger current – 5.0 A.
- Wiring: utilizes wire sizes 12 to 18 AWG (3.1 to 0.78 mm<sup>2</sup>)
- SLC specifications: Average SLC current is 1.287 mA. SLC data is transmitted between 24.0 VDC, 5 VDC, and 0 VDC at approximately 3.33 Kbaud.
- Battery fuse (F2): 15A, Slo-Blow.



## ACPS Programming

The ACPS-610 is programmable via the simple-to-use PK-PPS programming utility, which requires a Windows® PC with a USB port and cable. A copy of the PK-PPS programming utility is included with each ACPS-610. Programming may be performed during an on-line session with the ACPS-10, or previously saved programs may be downloaded to individual ACPS-610 units. The ACPS-610 requires the use of a minimum of 5 SLC address points, and will use up to 14 SLC address points to fulfill requirements for Canadian supervision and two stage operation.

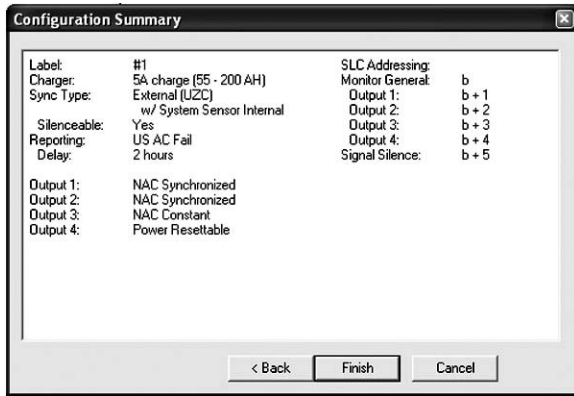

008023

Example of programming for the ACPS-610 using 6 addresses

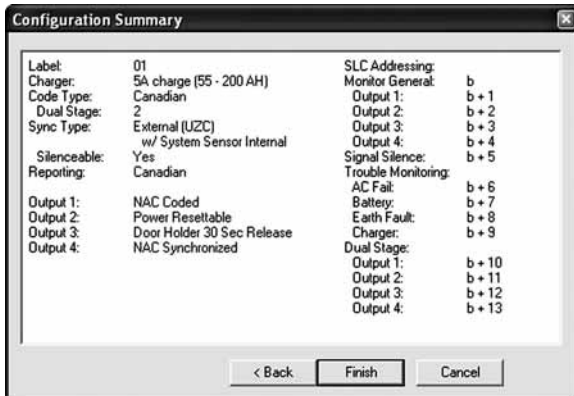

008024

Example for ACPS-610 using Canadian reporting with Two Stage

## Listings and Approvals

UL/ULC . . . . . S635

## Ordering Information

**ACPS-610:** Addressable charger power supply, with selectable built-in synchronization, and four built-in control modules. Includes installation instructions and PK-PPS programming utility CD. Requires Windows PDC with USB port and USB cable.

**BB-25:** The BB-25 can house one ACPS-610 and two 12 volt, 26 AH batteries.

**CAB-3/-4 Series:** The ACPS-610 can mount in any of the CAB-3/-4 Series cabinets. This can be in the bottom of the cabinet or a tier via a CHS-PS and CHS-BH.

**CHS-6:** When the power supply cannot be mounted in the CAB-3/-4 Series lowest row, the ACPS-610 will require the left two of the three chassis spaces.

Part No.	Description	Shipping Weight	
		lb	(kg)
435807	ACPS-610 Addressable Charger/Power Supply – 120 VAC	7	(3.2)
437344	ACPS-610E Addressable Charger/Power Supply – 240 VAC	7	(3.2)

# Detection and Control Components



## APS2-6R(E) 6.0 Amp Auxiliary Power Supply (IQ-318/IQ-636X-2)

### General

The APS2-6R(E) is a state-of-the-art, 150 watt, switching auxiliary power supply providing 24 VDC of filtered DC power. The APS2-6R(E) provides three 24 VDC output circuits, rated for 6.0 Amps in alarm and 4.0 Amps continuous. It is used for the operation of peripheral audible/visual devices (alarm signaling appliances) for the AUTOPULSE IQ-318 or the IQ-636X-2 control panels.

**Note:** The APS2-6R(E) can also be used with Legacy panels. Please refer to the APS2-6R(E) manual for more information.

### Features

- UL 864 Ninth Edition compliant
- Lightweight, compact design
- 120 or 220/240 VAC (@ 50/60 Hz) versions
- Output circuits with overload protection
- Built-in “brown-out” circuitry
- Diagnostic trouble LED
- Plug-in connector for in-cabinet applications and screw terminals for remote device applications
- Trouble supervision bus
- Shares battery and charger circuit with control panel
- Power-limited design, per UL requirements
- AC Fail supervision and reporting with field-selectable delay per UL 864
- Heavy-duty clamp-type terminals accept up to 12 AWG (3.1 mm<sup>2</sup>) wire
- Battery voltage supervision
- Low battery disconnect
- Mounts in a standard CAB-4 Series cabinet

### Standards and Codes

This power supply complies with the following standards:

- NFPA 72 National Fire Alarm Code
- UL 864 Standard for Control Units and Accessories for Fire Alarm Systems

In addition, the installer should be familiar with the following standards:

- NEC Article 300 Wiring Methods
- Applicable Local and State Building Codes
- Requirements of the Local Authority Having Jurisdiction
- The Canadian Electrical Code, Part 1

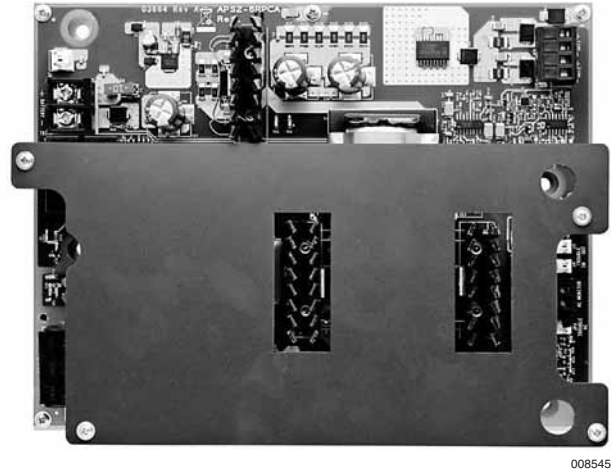

### Construction and Operation

When used with the CAB-4 Series (CAB-A4, -B4, -C4, or -D4), the APS2-6R(E) mounts to a CHS-4 or CHS-4L mounting chassis. If more than one APS2-6R(E) is necessary to meet the power requirements, connect additional APS2-6R(E) power supplies together as described in the Installation Instruction Manual for the APS2-6R(E).

Underwriters Laboratories requires that all Signaling Appliances be approved for use with the selected control system due to voltage operating range criteria. Use only those appliances listed for use with the associated control system. Refer to Device Compatibility Document, Part No. 50054.

### Specifications

#### Electrical Specifications

- AC primary input power (TB1): APS2-6R: 120 VAC, 50/60 Hz, 2.9 A., APS2-6RE : 220-240 VAC, 50/60 Hz, 1.5 A.
- DC secondary input power (TB3): TB3-1 (+), TB3-2 (-).
- 24 VDC output power (TB2): Total 6.0 A (4.0 A continuous).  
Circuit 1 (TB2-1, TB2-2): 3.0 A @ 24 VDC power-limited.  
Circuit 2 (TB2-3, TB2-4): 3.0 A @ 24 VDC power-limited.
- 24 VDC output power (J9): 6.0 A (4.0 A continuous), Non-Power Limited.
- Relay Contacts (TB4): AC Fail supervision over the SLC.
- Fuse: (F2 battery supervision): 32 VAC, 10.0 A, Fast-Acting Automotive Minifuse.
- Trouble supervision bus: J3 output: Form-A contact (open collector). J4 input: Form-A contact (open collector).  
**Note:** J3 and J4 can be interchanged.
- Loss of AC indication: Immediate indication (default); 1-2 hour delay (cut JP2); 2-3 hour delay (cut JP2 and JP3).



## Specifications (Continued)

### Mechanical Specifications

- ▶ The APS2-6R(E) measures approximately 8.63 in. (219 mm)
- ▶ x 6.63 in. (168 mm) x 2.38 in. (60 mm) and weighs approximately 2 lb (0.91 kg).

### Cabinet for Mounting

CAB-4 Series: Use CHS-4 and CHS-4L chassis for the AUTOPULSE IQ-636X-2 control panel.

### Listings and Approvals\*

UL Listed . . . . .S635

FM . . . . .Approved

\*Listings and Approvals are under NOTIFIER.

### Ordering Information

Part No.	Description	Shipping Weight	
		lb	(kg)
436863	APS2-6R 24-Volt Filtered Power Supply 120 VAC	2	(0.9)
436864	APS2-6RE 24-Volt Filtered Power Supply 220-240 VAC	2	(0.9)
417699	EOLR-1 12/24 VDC End-of-Line Relay	1	(0.5)
437070	EOLR-1A 12/24 VDC End-of-Line Relay (ULC)	1	(0.5)
419586	CHS-4 Four-Module Chassis	9	(4.1)
437051	CHS-4 Four-Module Chassis (ULC)	9	(4.1)
418576	CHS-4L Four-Module Chassis (Low Profile)	1	(0.5)
437052	CHS-4L Four-Module Chassis (Low Profile) (ULC)	1	(0.5)



## UDACT – Universal Digital Alarm Communicator Transmitter (IQ-318/IQ-636X-2)

### Features

- Dual phone lines
- Dual telephone line voltage detect
- Surface Mount Technology
- Compact in size 6 3/4 x 4 1/4 inch (172 x 108 mm)
- Built-in programmer
- Built-in 4 character red 7-segment LED display
- Manual Test Report function
- Manual Transmission Clear function
- Mounts in a separate enclosure (ABS-8RB)
- Communicates vital system status
- Annunciation of UDACT Troubles including: loss of phone lines, communication failure with either Central Station, total communication failure
- Troubleshoot Mode converts keypad to DTMF touchpad
- Individual LEDs for: Power, EIA-485 Loss, Manual Test, Kissoff, Comm Fail, Primary Line Seize, Secondary Line Seize, and Modem Communications
- Open Collector relay driver for Total Communications Failure or UDACT trouble
- Real-time clock
- Extensive transient protection
- Simple EIA-485 Interface to host unit

### Description

The Universal Digital Alarm Communicator Transmitter (UDACT) is designed for use on the AUTOPULSE IQ-318 and AUTOPULSE IQ-636X-2 control units. It is also designed for use on the Intelligent Network Annunciator (INA), software release 2.8 or higher. When used in conjunction with the INA, the UDACT can report the status of all control units on **NOTI-FIRE-NET™**. The UDACT transmits system status to UL listed Central Station Receivers via the public switched telephone network.

The UDACT is compact in size and may be mounted externally in a separate cabinet. EIA-485 annunciator communications bus and regulated 24 volt connections are required.

The UDACT is capable of transmitting the status of software zones (Alarm and Trouble), System Trouble, Panel Off-Normal, Supervisory, Bell Trouble, Low Battery, and AC Fail. When used with the AUTOPULSE IQ-318 and IQ-636X-2 the UDACT is capable of reporting 567 points. Reporting may be in the form of software zones (99 plus 16 special), panel circuits 1-4, panel output modules 1-64, and 192 points per SLC loop (the first 96 detector and 96 module addresses).

The Universal Digital Alarm Communicator Transmitter (UDACT) provides the means to create a powerful, low cost, local area network solution for any application involving multiple facilities spread over a small geographic area, such as hospitals, college campuses, shopping malls, prisons, airports, grouped government facilities, power plants, large commercial facilities, and much more.

UDACT IN ABS-8R (SHOWN WITH COVER REMOVED)

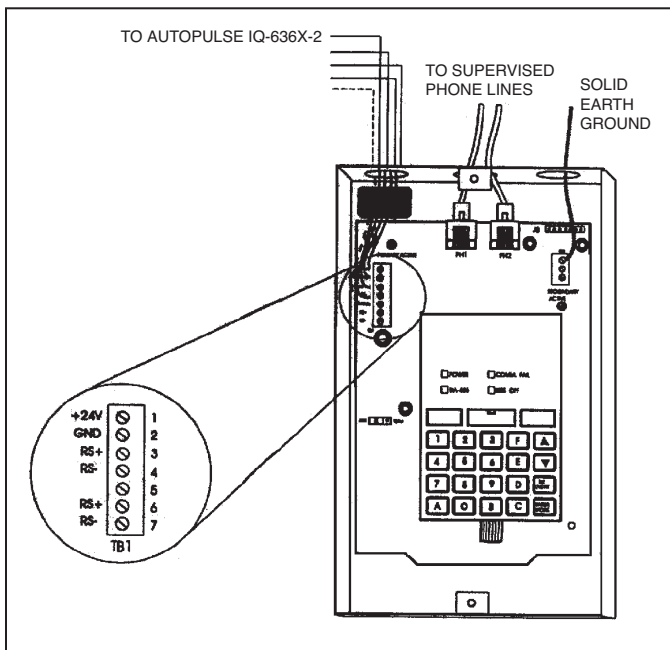

002374

LOCAL AREA NETWORK

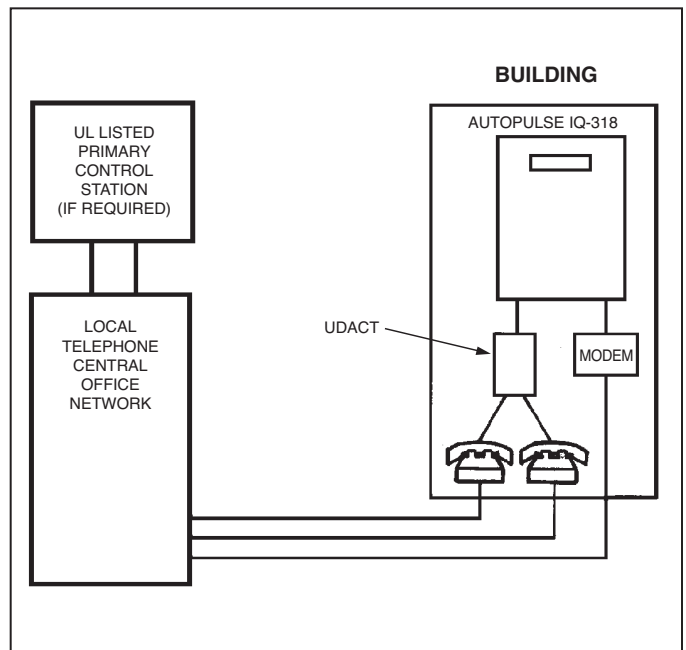

002373

The UDACT when used in the Contact ID format transmits detailed system status via the standard public switched telephone network to a digital receiver. The telephone network becomes the "network gateway" from the FACP to the digital receiver and to an optional UniNet monitor.

Contact ID is a transmission format enabling transmission of alarm and trouble conditions on a bi-point basis. Three groups of information are transmitted to the central station: a four-digit account code, a group number (00-99), and the device or zone number (000-999). Each of these three information groups is programmable. Because of the virtually unlimited number of combinations, the number of systems, points and/or zones transmitted is boundless.

### Technical Information

Standby current: . . . . . 40 mA  
 Current while communicating: . . . . . 75 mA  
 Maximum current while communicating  
 and with open collector output activated: . . . . . 100 mA  
 Voltage: . . . . . Regulated 24 volts  
 Range: . . . . . 21.2 to 28.2 volts

Required software:

- IQ-301 EPROM = 73609 (or higher)
- IQ-396X EPROM = #AFP4R 2.0 (or higher)
- IQ-318 = All
- IQ-636X = All
- IQ-636X-2 = All

### Listings and Approvals\*

UL . . . . . S635  
 ULC . . . . . CS100 Vol. VII  
 Factory Mutual (FM) . . . . . Approved  
 California State Fire Marshal (CSFM) . . . . . 7300-0028:174  
 MEA . . . . . 328-94-E  
 Industry Canada . . . . . 2132 6030 A  
 FCC . . . . . IWGUSA-20723-AL-E

\* Listings and Approvals are under NOTIFIER

### Ordering Information

Part No.	Description	Shipping Weight	
		lb	(kg)
419411	UDACT Universal Digital Alarm COM/XMTR	2	(0.9)
436996	ABS-8RB Surface Back Box	1	(0.5)

### COMPATIBILITY CHART

Format # (Addresses 16 & 42)	Ademco 685 (1)	Silent Knight 9000	ITI CS-400 (3)	FBI CP220FB	Osborne Hoffman Models 1 & 2	Radionics 8000/ 5800 (5)	Senco 3000R (7)	Surguard MLR-2 (9)
0 4+1 Ademco Express	✓			✓				✓
1 4+2 Ademco Express	✓			✓	✓(8)			✓
2 3+1/Standard/1800/2300	✓	✓ (2)	✓	✓ (4)	✓	✓ (5,6)	✓	✓
3 (Not Used)								
4 3+1/Standard/1900/1400	✓	✓ (2)		✓ (4)	✓		✓	✓
5 (Not Used)								
6 4+1/Standard/1800/2300	✓	✓(2)	✓	✓ (4)	✓	✓ (5)	✓	✓
7 (Not Used)								
8 4+1/Standard/1900/1400	✓	✓ (2)		✓ (4)	✓		✓	✓
9 (Not Used)								
A 4+2/Standard/1800/2300	✓	✓ (2)	✓	✓ (4)	✓	✓ (5)	✓	✓
B (Not Used)								
C 4+2/Standard/1900/1400	✓	✓ (2)		✓ (4)	✓		✓	✓
D (Not Used)								
E Ademco Contact ID	✓			✓	✓			✓
F (Not Used)								

- (1) With 685-8 Line Card with Rev 4.4d software
- (2) With 9002 Line Card Rev 9035 software or 9032 Line Card with 9326A software
- (3) Rev 4.0 software.
- (4) FBI CP220FB Rec-11 Lin Card with Rev 2.6 software and a memory card with Rev 3.8 software

- (5) Model 6500 with Rev 600 software
- (6) Model 6000 with Rev 204 software
- (7) With Rev B control card at Rev 1.4 software and Rev C line card at Rev 1.5 software
- (8) Model 2 only
- (9) Version 1.62 software



(Page Left Intentionally Blank)



# Detection and Control Components



## CHG-120 Battery Charger and Meters (IQ-318/IQ-636X-2)

### Features

- Charges sealed lead-acid batteries
- Automatic float-type battery charger
- Rated for batteries of 25 to 120 ampere-hours
- Obtains full float voltage within 48 hours
- For use on any 24-volt FACP which can handle the specified batteries and can disable the local charger
- AC Fail delay (central station applications) per latest NFPA requirements
- Form-C Trouble contact
- Dual outputs, for easy load distribution
- Diagnostic LEDs:
  - Primary AC On
  - Charger Trouble
  - Ground Fault
  - Hi Charge
  - Lo Charge
  - Battery Voltage Level (3 LEDs)
  - Low Battery
- Optional BB-55 battery cabinet
- Field-selectable input voltage, 120 VAC or 230 VAC
- Charges:
  - 25 AH batteries within 9 hours
  - 55/60 AH batteries within 20 hours
  - 120 AH batteries within 38 hours

### Applications

Use the CHG-120 battery charger with the AUTOPULSE IQ-318 or IQ-636X-2 control units when batteries required for standby are rated equal to or greater than 25 ampere-hours. Up to two batteries may be charged when either the 25AH or 60AH are installed.

### Description

The CHG-120 battery charger is a state-of-the-art battery charging system designed for use with the AUTOPULSE IQ-318 or IQ-636X-2. It is designed to charge lead-acid batteries between 25 and 120 ampere-hours (AH).

The CHG-120 consists of a PC board and mounting chassis. Charging current is provided automatically when the battery voltage falls below the charger's output voltage.

### CHG-120 BATTERY CHARGER

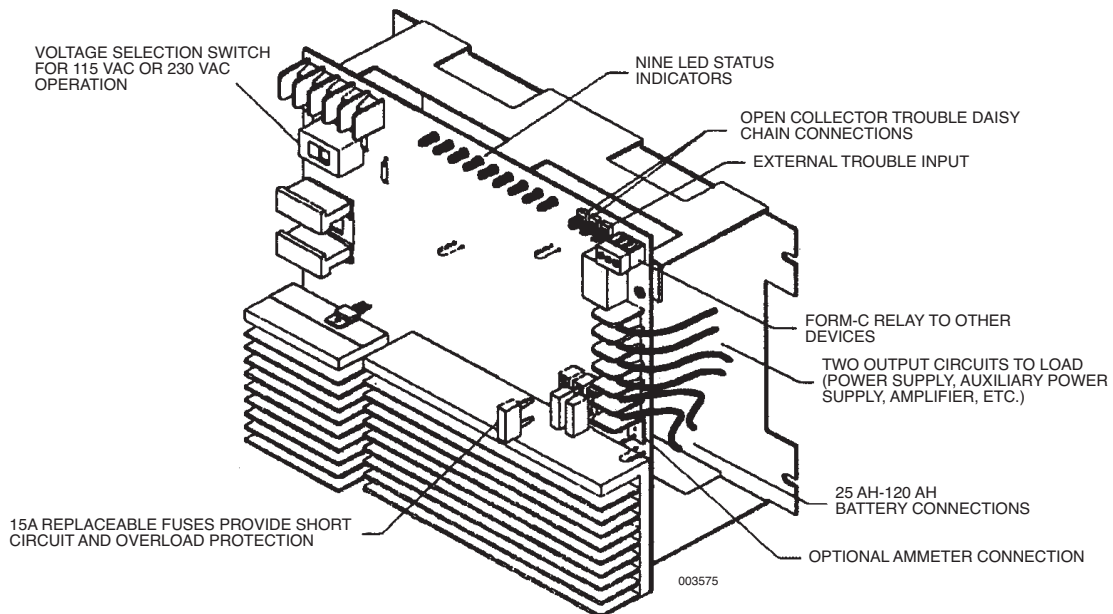







## Annunciator Back Boxes (IQ-318/IQ-636X-2)

### Description

The Annunciator back boxes are used for mounting the LCD-80, AEM, ACS, or AFM annunciator modules.

**ABS-1B** – The Annunciator Surface Box-1 provides for the remote mounting of a single ACM or AFM annunciator in a surface-mount enclosure. Knockouts are provided for use with 1/2 in. conduit. The annunciator mounts directly to the ABS-1B without a dress plate.

**ABS-2B** – The Annunciator Surface Box-2 provides for the surface mounting of one ACM-16AT/AEM-16AT combination or one ACM-32A/AEM-32A combination. Knockouts are provided for use with 1/2 in. conduit. The annunciators mount directly to the ABS-2B without a dress plate.

### ABS-1B AND ABS-2B SURFACE BACK BOXES

ABS-1B: 8 1/2 IN. (H) x 4 1/2 IN. (W) x 1 3/8 IN. (D)  
(216 mm (H) x 114 mm (W) x 35 mm (D))

ABS-2B: 8 1/2 IN. (H) x 8 15/16 IN. (W) x 1 3/8 IN. (D)  
(216 mm (H) x 227 mm (W) x 35 mm (D))

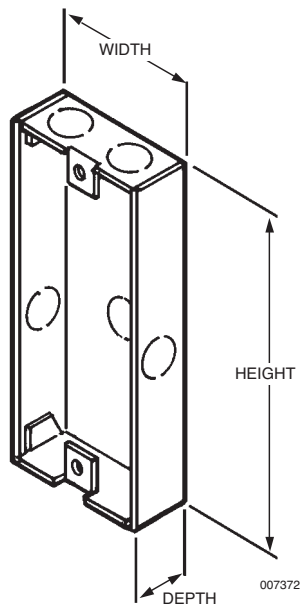

**ABF-1B** – The Annunciator Flush Box-1 provides for the remote mounting of a LCD-80 or a single ACM or AFM annunciator in a flush-mount enclosure. Knockouts are provided for use with 1/2 in. conduit. The ABF-1B includes a painted gray metal trim plate, mounting hardware, and an adhesive-backed Annunciator Label for the dress plate.

### ▶ ABF-1B FLUSH BACK BOX

▶ 9 15/16 IN. (H) x 4 5/8 IN. (W) x 2 1/2 IN. (D)  
(252 mm (H) x 117 mm (W) x 64 mm (D))

TRIMPLATE: 11 IN. (H) x 6 1/4 IN. (W)  
(279 mm (H) x 159 mm (W))

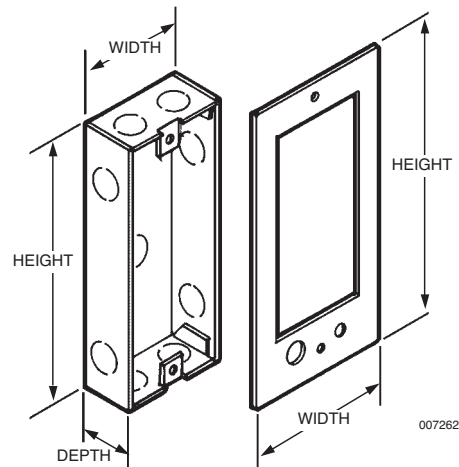

**ABS-1TB** – The ABS-1TB is an attractive surface mount back box for mounting a LCD-80 or one ACM or AFM annunciator.

### ABS-1TB SURFACE BACK BOX

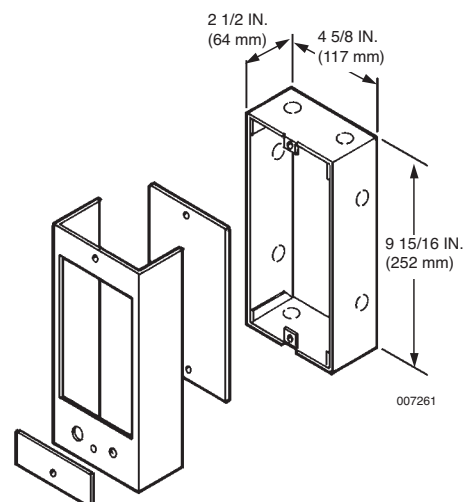

## Technical Information

### Box Type    Annunciator Compatibility

---

ABS-1B	ACM-16AT, ACM-32A, AFM-16AT, AFM-32A
ABS-2B	ACM-16AT/AEM-16AT, ACM-32A/AEM-32A
ABF-1B*	LCD-80, ACM-16AT, ACM-32A, AFM-16AT, AFM-32A
ABS-1TB	LCD-80, AFM-16AT, AFM-32A, ACM Type with AKS-1B (key switch)

\*Includes painted black metal trim plate

## Approvals

UL ..... S635

## Ordering Information

Part No.	Description	Shipping Weight	
		lb	(kg)
417657	ABF-1B, Annunciator Back Box, Flush, Single	1	(0.45)
417493	ABS-1TB, Annunciator Back Box, Surface Single, Deep	1	(0.45)
417660	AKS-1B, Annunciator Key Switch	1	(0.45)

# Detection and Control Components



## FDU-80G 80-Character Liquid Crystal Display Fire Annunciator (IQ-318/IQ-636X-2)

### General

The FDU-80G is a compact, 80 character, backlit LCD Fire Annunciator for use with the AUTOPULSE IQ-318 and IQ-636X-2 Fire Alarm Control Panels (FACPs). The FDU-80G mimics the display of the control panel and displays complete system point status information. Up to 32 FDU-80Gs may be connected onto the EIA-485 Terminal Mode port of each control panel. The FDU-80G requires no programming, which saves times during system commissioning.

The FDU-80G can be used on the same data loop as the LCD-80/LCD-80TM annunciators revision 1.6 software or higher.

### Features

- 80-character Liquid Crystal Display
- Mimics all display information from the host panel
- Control switches for System Acknowledge, Signal Silence, Drill and Reset with enable key
- System status LEDs for Power, Alarm, Trouble, Supervisory, and Alarm Silenced
- No programming necessary – FDU-80G connects to the terminal mode port
- Displays device type identifiers, individual point alarm, trouble or supervisory, zone and custom alpha labels
- Time and date display field
- Aesthetically pleasing design
- May be powered by 24 VDC from the host FACP or by remote power supplies (requires 24 VDC)
- Up to 32 FDU-80G annunciators per FACP
- Plug-in terminal blocks for ease of installation and service
- Can be remotely located up to 6,000 ft (1828.8 m) from host control panel
- Local piezo sounder with alarm and trouble resound
- ▶ Semi-flush mounts to 2.188 in. (56 mm) minimum deep, three-gang electrical box or three-gangable electrical switchbox
- Surface mounts to SBB-3 surface backbox



007714

### Operation

The FDU-80G annunciator provides the FACP with point annunciation with full display text on an 80-character LCD display. The FDU-80G also provides an array of LEDs to indicate system status, and also includes control switches for remote control of critical system functions.

The FDU-80G provides the FACP with up to 32 remote serially connected annunciators. All field-wiring terminations on the FDU-80G use removable, compression-type terminal blocks for ease of wiring and circuit testing.

Communication between the FACP and the annunciators is accomplished over an EIA-485 serial interface, which greatly reduces wire and installation cost over traditional systems. Six wires total are required: four for the EIA-485 communications (two in and two return); and two for the 24 VDC regulated power. Dip switches control local functions such as: piezo disable, control switches/key switch disable, transmit/receive mode.

## FDU-80G Terminal Mode Wiring Example

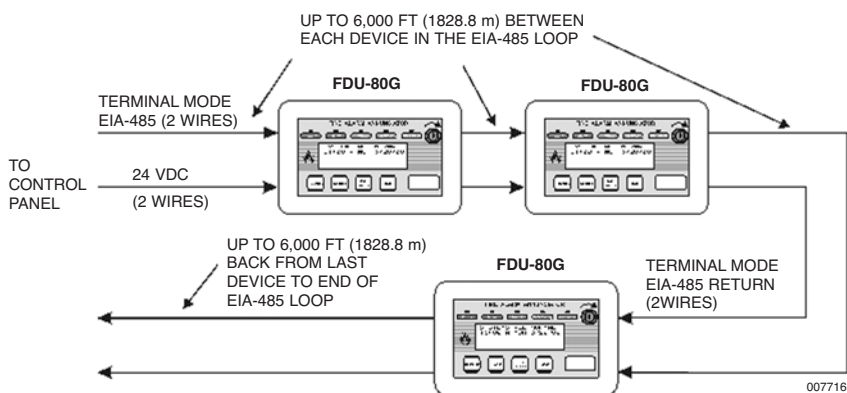

### Notes:

- ▶ 1. EIA-485: Maximum of 6,000 ft (1828.8 m) cable length from FACP to FDU-80G annunciators and back to FACP (6,000 ft (1828.8 m) total). Circuit is power limited.
- 2. Up to 32 FDU-80G annunciators may be used on the EIA-485 circuit. When multiple FDU-80Gs are used, certain panels will require additional power supplies (refer to panel documentation).
- 3. Between each FDU-80G annunciator are four wires: a twisted-shielded pair for data communications and a pair for 24 VDC power. The return circuit only requires two wires for data communication supervision, wired from the last FDU-80G annunciator on the loop.
- 4. The FDU-80G annunciator can be semi-flush mounted in a three-gang electrical box with a minimum depth of 2.188 in. (5.6 cm).

### Listings and Approvals\*

UL ..... S635  
 FM ..... Approved  
 California State Fire Marshal ..... 7120-0028:209

\*Listings and Approvals are under NOTIFIER.

### Ordering Information

Part No.	Description	Shipping Weight	
		lb	(kg)
435530	FDU-80G Annunciator	5.0	(2.3)
▶ 436141	SBB-3, Back Box, Surface	2.0	(0.9)

# Detection and Control Components



## LCD2-80 Liquid Crystal Display Terminal Mode Annunciator (IQ-318, IQ-636X-2)

### General

The LCD2-80 is a backlit LCD annunciator for the Addressable AUTOPULSE fire suppression control panels that support the 80-character display format. The LCD2-80 may be connected onto the four-wire EIA-485 terminal port.

The LCD2-80 mimics the display of the IQ-318 and IQ-636X-2 control panels, the NCA-2 annunciator, and legacy panels (IQ-301, IQ-396X, and IQ-636X) that supported the LCD-80/LCD-80TM. Up to 32 LCD2-80 units can annunciate and provide remote reset, acknowledge, drill and silence of the control panel from remote locations.

**Note:** The LCD2-80 can be used with legacy panels that supported the LCD-80 terminal mode operation. Please refer to the LCD2-80 manual for more information.

### Features

- 80-character backlit Liquid Crystal Display (20 characters x 4 lines)
- Display mimics panel or NCA annunciator
  - Event message
  - 20 characters for point label
  - 12 characters for extended label
  - Time, date, and point address
- Control switches for System Acknowledge, Signal Silence Drill, and System Reset
- Mounts up to 6,000 ft (1828.8 m) segments between units
- Local piezo sounder with alarm/trouble resound
- Displays all analog, addressable points
- Displays device type identifiers
- Displays device and zone custom alpha labels
- Mounts to any CHS-4 chassis slot
- Slide-in label can be customized



008850

- Flush/surface/panel mount option
- No programming necessary; LCD2-80 displays time, date, and custom messages received from the compatible panel or network annunciator
- LCD2-80 is 8.25 in. (210 mm) high, 4.375 in. (111 mm) wide, and 1.75 in. (44 mm) deep
- Up to 32 LCD2-80 annunciators may be used on one EIA-485 circuit

**Note:** The LCD2-80 must have sufficient regulated 24-volt power.

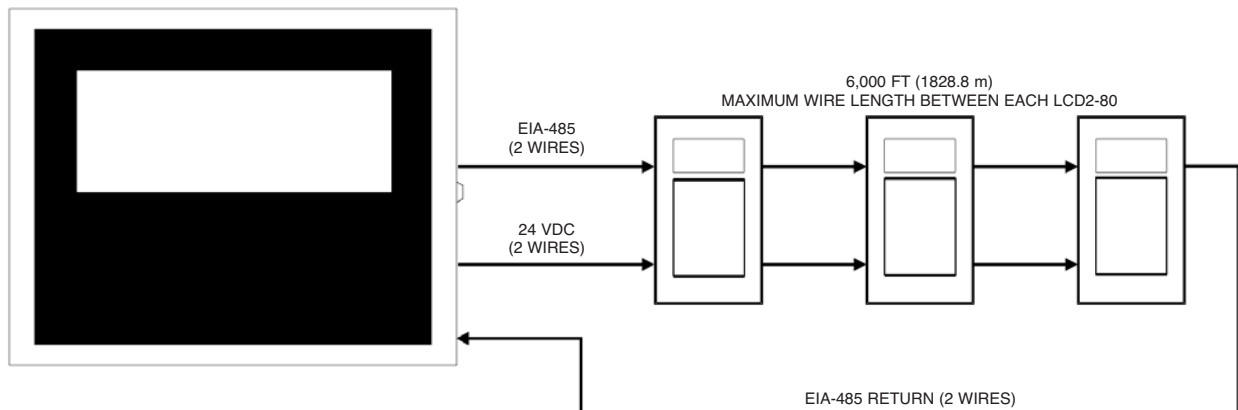

IQ-318, IQ-636X-2 or NCA-2 Connecting to LCD2-80

008851

## Agency Listings and Approvals

These listings and approvals apply to the modules specified in this document. In some cases, certain modules or applications may not be listed by certain approval agencies, or listing may be in process. Consult factory for latest listing status.

UL Listed ..... S635  
ULC Listed ..... S635  
FM ..... Approved  
FDNY ..... COA# 6067, 6065  
CSFM ..... 7165-0028:0243, 7165-0028-0224

## Ordering Information

LCD2-80: Liquid Crystal Display Terminal Mode Annunciator. May be connected onto the four-wire EIA-485 terminal port.

ADP-4B: Annunciator dress plate, black. Allows panel mounting of up to four LCD2-80 modules in a CAB-4 Series cabinet.

ABF-1B: Annunciator flush box, 9.938 in. (252 mm) high, 4.625 in. (117 mm) wide, and 2.5 in. (64 mm) deep. Order AKS-1B key switch.

ABS-1TB: Deep surface back box (mounts one LCD2-80).

AKS-1B: Key Switch (black) to enable/disable controls when mounted in ABF-1B or ABS-1TB.

Part No.	Description	Shipping Weight	
		lb	(kg)
438773	LCD2-80 Terminal Mode Annunciator	2	(0.9)
433520	ADP-4B Annunciator Dress Plate	1	(0.5)
417657	ABF-1B Annunciator Back Box, Flush, Single	1	(0.5)
417493	ABS-1TB Annunciator Back Box, Surface, Deep	1	(0.5)
417660	AKS-1B Annunciator Key Switch	1	(0.5)

# Detection and Control Components



## NCA-2 AUTOPULSE Series Network Control Annunciator (IQ-318/IQ-636X-2)

### General

The NOTIFIER NCA-2 is a second-generation Network Control Annunciator compatible for use with AUTOPULSE IQ-318 and IQ-636X-2 fire alarm control panels, as well as first-generation NCA Network Control Annunciators. The NCA-2 provides system control and display capabilities.

The NCA-2 display consists of a 640-character backlit LCD display, and a control interface consisting of “soft” keys used to navigate screen menus, “hard” keys with fixed control functions, and a QWERTY keypad.

### Hardware Features

- Listed to UL Standard 864, 9th edition
- Full supervision of all inputs and network integrity
- Enhanced-format 640-character LCD display with back-lighting
- ACS bus for LED or graphic annunciators (EIA-485)
- Optically isolated printer interface (EIA-232)
- 11 LED status indicators: Power, Controls Active, Fire Alarm, Pre-Alarm, Security, Alert, Supervisory, Trouble, Signal, Silence, CPU Failure, Point Disabled, Other Event
- Alphanumeric QWERTY rubber keypad
- Four status relays: Alarm, Trouble, Supervisory, Security (Form-C)
- Nonvolatile real-time clock can be synchronized with network by master node
- Optional Security Keyswitch enable Keypad functions
- Optional Security Tamper switch
- Supports up to 32 remote ACS annunciators and modules
- Requires 24 VDC and a network connection

### Function Features

- Individual Enable/Disable or Group Enable/Disable local for networked AUTOPULSE series panels
- Lamp Test (local to NCA-2)
- History Buffer (1000 Alarm events; 4000 System events)
- Print NCA-2 programming and history reports
- Report status of panels and their respective field devices to a central station via a single UDACT
- One Master level, nine User level passwords: The Master can assign each User access levels (programming, alter status)
- Interactive Summary Event Count display, event handling package
- Online programming and alter-status programs
- Intuitive user guidance program including interactive soft keys

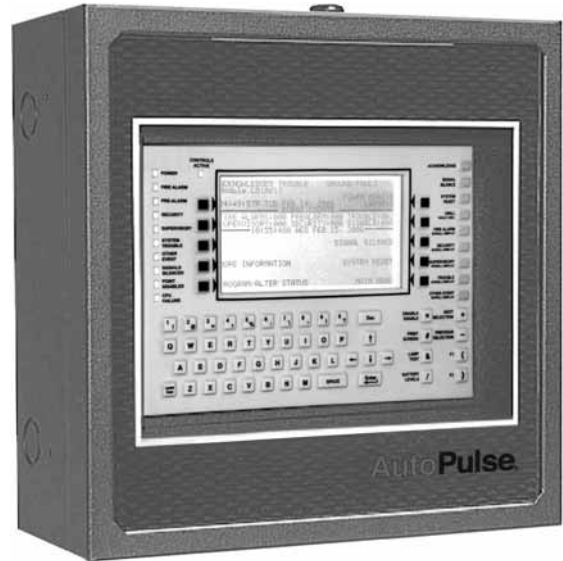

007715

- Enhanced Read Status/Alter Status displays
- New history filters for report displaying and printing: All Events, Only Alarms, Only Troubles, Only Supervisory, Only, Security, Time Interval, Point Range
- Advanced/Basic Walk-Test program
- Timer control for Auto Silence, AC Fail Delay
- Meets Canadian ULC display requirements
- Environmental adjustment controls to maximize LCD legibility
- Meets NFPA requirements for Firefighter Smoke Control Station (FSCS) and HVAC

### NCA-2 Indicators and Controls

#### LED Indicators:

- **Power** (green) illuminates when 24 VDC power is applied; LED goes out if power is removed and NCA-2 is using a battery.
- **Controls Active** (green) illuminates to indicate that the NCA-2 control functions are active.
- **Fire Alarm** (red) illuminates when at least one fire alarm event exists; flashes when any of these events remain unacknowledged.
- **Pre-Alarm** (red) illuminates when at least one pre-alarm event exists; flashes when any of these events remain unacknowledged.
- **Security** (blue) illuminates when at least one security event exists; flashes when any of these events remain unacknowledged



## NCA-2 Indicators and Controls (Continued)

### LED Indicators: (Continued)

- **Supervisory** (yellow) illuminates when at least one supervisory event exists (i.e., sprinkler valve off normal, low pressure, fire pump running, guard's tour, etc.); flashes when any of these events remain unacknowledged.
- **System Trouble** (yellow) illuminates when at least one trouble event exists; flashes when any of these events remain unacknowledged.
- **Other Event** (yellow) illuminates for any category of event not listed above; flashes when any of these events remain unacknowledged.
- **Signals Silenced** (yellow) illuminates if the NCA-2 Silence key has been pressed or if any other node sent a Network Silence command; flashes if only some points on a node are silenced.
- **Point Disabled** (yellow) illuminates when at least one disable exists on the network or in the system.
- **CPU Failure** (yellow) activated by the watchdog timer hardware, indicates an abnormal hardware or software condition. Contact technical support.

### Fixed Function Keys

- Acknowledge
- Signal Silence
- System Reset
- Drill
- Fire Alarm Scroll/Display
- Security Scroll/Display
- Supervisory Scroll/Display
- Trouble Scroll/Display
- Other Event Scroll/Display

The five keys labeled Scroll/Display allow the user to scroll through messages for the particular event type. For example, pressing the Fire Alarm Scroll/Display key will scroll through all fire alarm events, as details of each are shown in the display area of the NCA-2.

**Note:** The Other Event Scroll/Display key also scrolls between Pre-Alarm and Disabled events.

- **Acknowledge:** Press this key to acknowledge off all active events.
- **Signal Silence:** Press this key to turn off all control modules, notification appliance circuits, and panel output circuits that have been programmed as Silenceable.
- **System Reset:** Press this key to clear all latched alarms and other events and turn off event LEDs.
- **Drill Hold 2 Sec:** Press this key, holding it down for two seconds, to activate all silenceable output circuits.

## Special Function Keys

- **Print Screen:** Press this key to print what is currently on the LCD screen.
- **Lamp Test:** Press this key to test the LED indicators on the left of the keypad and to check firmware revision numbers.
- **Next Selection/Previous Selection:** These keys are used when setting parameters in NCA-2 data fields; for example, choosing a device type as a filter for requesting a Node History.
- **Battery Level:** Press this key to display voltage and charging current level for system batteries.

## Specifications

Temperature and humidity ranges: This system meets NFPA requirements for operation at 32 °F-120 °F (0 °C-49 °C) and at a relative humidity (noncondensing) of 85% at 86 °F (30 °C) per NFPA, and 93% ± 2% at 89.6 °F ± 1.1 °F (32 °C ± 2 °C) per ULC. However, the useful life of the system's standby batteries and the electronic components may be adversely affected by extreme temperature ranges and humidity. Therefore, it is recommended that this system and all peripherals be installed in an environment with a nominal room temperature of 60 °F-80 °F (15 °C-27 °C).

## Electrical Requirements

The NCA-2 may be powered from a Main Power Supply AMPS-24(E) mounted in the NCA-2 cabinet (see specifications below); or from any UL Listed non-resettable 24 VDC source from an AUTOPULSE control panel.

The battery on the NCA-2 motherboard is for RTC and SRAM; holds the history memory through power failure. Replacements are available.

**Power source:** 1) AMPS-24 (120 VAC, 50/60 Hz, 4.5 A maximum) or AMPS-24E (240 VAC, 50/60 Hz, 2.25 A maximum) power supply; 2) the AUTOPULSE IQ-636X-2 on-board power supply; or 3) a supervised +24 VDC power supply that is UL/ULC Listed for fire protective service

**Total output 24 VDC power:** 4.5 V in alarm.

## Listings and Approvals\*

These listings and approvals apply to the NCA-2. In some cases, certain modules or applications may not be listed by certain approval agencies, or listing may be in process. Consult factory for latest listing status.

UL .....	S635
ULC .....	S635
CSFM .....	7165-0028:243, 7170-0028:244
MEA .....	128-07-E

\*Listings and Approvals are under NOTIFIER.

## Ordering Information

Part No.	Description	Shipping Weight lb (kg)
434956	NCA-2 (Network Control Annunciator)	5.0 (2.3)



## VeriFire™ Tools Programming and Test Utility (IQ-318, IQ-636X-2, NCA-2)

### General

**VeriFire™ Tools** is a programming and test utility for the ▶ AUTOPULSE IQ-318, IQ-636X-2, and NCA-2 with offline and online capabilities that can greatly reduce installation programming time and increase confidence in the site-specific software. It is Windows® based and provides technologically advanced capabilities to aid the installer. The installer may create the entire program for the control panel in the comfort of the office, test it, store a backup file, then bring it to the site and download from a laptop into the panel.

The program includes error checks for common programming mistakes, such as an input point that does not activate any outputs, or an output point that is not linked to any inputs. In online mode, users can perform point “read status” functions, change panel and device labels, and change detector sensitivities.

VeriFire™ Tools includes a compare routine, pictured at right, that can also greatly help the installer. When a new program is created, it may be compared with a previous version and differences are highlighted. If the program is modified from the panel keypad, it may be uploaded into **VeriFire™ Tools**, and compared with the previous version stored on disk. The identification of program **differences** greatly helps the installer in testing the installation. NFPA 72 requires that acceptance test of a fire alarm system be performed on 100% of all points that are “known” to be modified. **VeriFire™ Tools** allows the installer to determine the exact points that are changed.

### Product Line Information

**433365 – VeriFire™ Tools** CD-ROM. Contains programming ▶ software for the AUTOPULSE IQ-318, IQ-636X-2, and NCA-2. Includes local panel hardware connection.

**432798 – VeriFire™ Tools** CD-ROM contains software only.

### PC Specifications (minimum requirement)

- Pentium® II 300 MHz
- 64 MB of RAM
- 50 MB of hard drive space
- Windows® 98 Second Edition, ME, NT, 2000, or XP (Windows® 95 is not supported)
- Serial port
- XGA video (1024 x 768)

VeriFire™ is a trademark of Honeywell International. Microsoft® and Windows® are registered trademarks of Microsoft Corporation. Pentium® and Intel® are registered trademarks of Intel Corporation.





## SLR-24H Photoelectric/Heat Smoke Detector (IQ-318/IQ-636X-2 (with FZM))

### Features

- Self-restoring integral 135 °F (57 °C) heat sensor, 50 ft (15 m) rating
- Low profile, 2.4 in. (60 mm) high – with base
- 2 or 4 wire base compatibility, relay bases available
- Highly stable operation, RF/Transient protection
- Low standby current, 45µA at 24 VDC
- Two built-in power/sensitivity supervision/alarm LEDs
- Non-directional smoke chamber
- Vandal resistant security locking feature
- Built-in magnetic go/no go detector test feature
- Removable smoke labyrinth for cleaning or replacement
- Automatic Sensitivity window verification function meets outlined requirements in NFPA 72, Chapter 7, Inspection, Testing and Maintenance
- Backwards compatible with SLK and SIH detectors

### Applications

The SLR-24H Photoelectric/Heat Smoke Detectors are intended for use in commercial, industrial, and institutional buildings. The detectors are placed primarily in clean, indoor environments where early warning fire detection is required. It is best suited for smoldering or flaming fires.

The 135 °F (57 °C) heat sensor can initiate an alarm independently. The heat detector is UL listed for 50 ft (15 m) spacing when used for evacuation alarm, if used for suppression release the spacing should be reduced.

The detectors are used in combination with an AUTOPULSE Control System and a fire suppression system for automatic detection, alarm, equipment control, and fire suppression system release capabilities.

### Description

The SLR-24H photoelectric/heat smoke detector utilizes two bicolor LEDs for indication of status. In a normal standby condition the LEDs flash Green every 3 seconds. When the detector senses that its sensitivity has drifted outside the UL listed sensitivity window, the LEDs will flash Red every 3 seconds. When the detector senses smoke and goes into alarm, the status LEDs will latch on Red.

The detector utilizes an infrared LED light source and silicon photo diode receiving element in the smoke chamber. In a normal standby condition, the receiving element receives no light from the pulsing LED light source. In the event of a fire, smoke enters the detector smoke chamber and light is reflected from the smoke particles to the receiving element. The light received is converted into an electronic signal.

Signals are processed and compared to a reference level, and when two consecutive signals exceeding the reference level are received within a specified period of time, the time delay circuit triggers the SCR switch to activate the alarm signal. The status LEDs light continuously during the alarm period.

### DIMENSIONS – NS6-224 BASE

- ▶ TO 4 IN. (102 mm) SQUARE OR
- ▶ 4 IN. (102 mm) OCTAGON

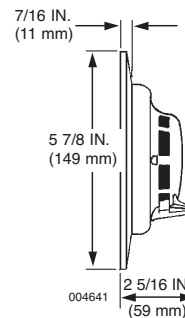
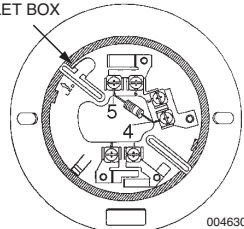

### DIMENSIONS – NS4-224 BASE

- ▶ TO 3 IN. (76 mm)

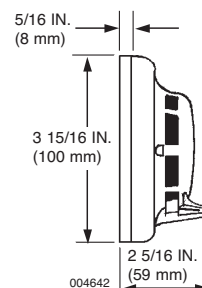
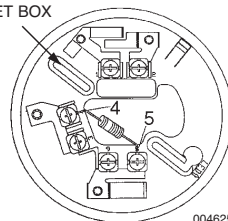

### DIMENSIONS – HSB-21 BASE

- ▶ TO 4 IN. (102 mm) SQUARE OUTLET BOX

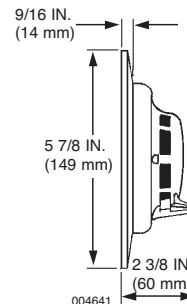
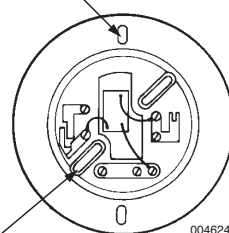

- ▶ TO 3 IN. (76 mm) OR 4 IN. (102 mm)

### DIMENSIONS – HSC-224RA BASE

- ▶ TO 4 IN. (102 mm) SQUARE OR 4 IN. (102 mm) OCTAGON

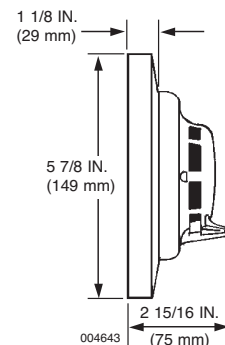
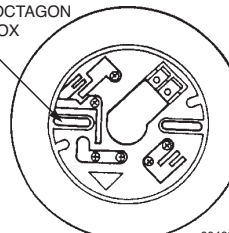

**Technical Information**

Detector Base/Control Unit Compatibility

Detector Base (Part No.)	AUTOPULSE IQ-318, IQ-636X-2 FZM-1
NS6-224 (427598)	Yes
HSB-21 (417457)	No
NS4-224 (427599)	Yes
HSC-224RA (416849)	No

Heat Detector: . . . . 135 °F (57 °C) self-restoring, fixed temp.  
 Light Source: . . . . . GaAl as infrared emitting diode  
 Rated Voltage: . . . . . 17.6 to 33.0 VDC  
 Working Voltage: . . . . . 15 to 33.0 VDC  
 Maximum Allowable Voltage: . . . . . 42 VDC  
 Supervisory Current: . . . . . 45 µA maximum @ 24 VDC  
 Surge Current: . . . . . 160 µA maximum @ 24 VDC  
 Alarm Current: . . . . . 150 mA maximum @ 24 VDC  
 Ambient Temperature: . . . . +32 °F to +120 °F (0 °C to 49 °C)  
 Color: . . . . . Bone White  
 Sensitivity Test Feature: . . . . Automatic sensitivity window verification test  
 Air Velocity: . . . . . Maximum 300 FPM

**WIRING DIAGRAM – TWO WIRE OPERATION  
 NS4 AND NS6 SERIES BASE**

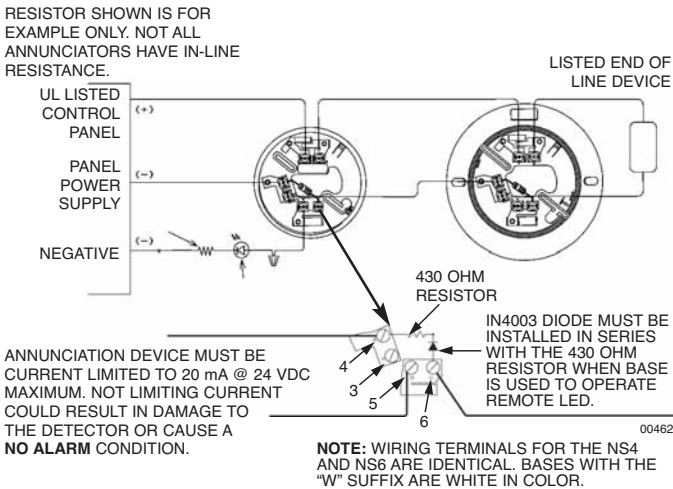

**WIRING DIAGRAM – HSB-21 AND HSC-224RA\*  
 STANDARD BASES, STYLE B**

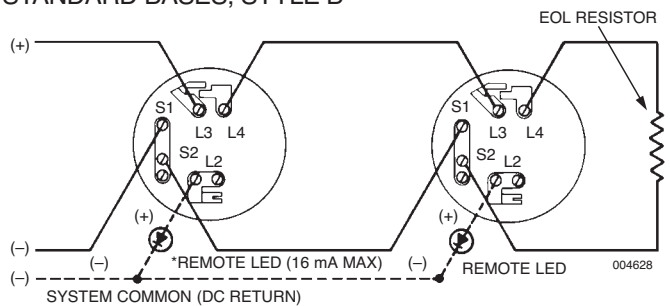

**Mounting Guidelines**

The detector bases are designed for surface mounting. The detector head can be inserted or removed from the base without disrupting the wiring connections.

The following bases are compatible with the SLR-24H Photoelectric/Heat Smoke Detector:

Base	Type of Mounting Box
HSB-21	4 in. (102 mm) Octagon, 4 in. (102 mm) Square
NS4-224	3 in. (76 mm) Octagon
NS6-224	4 in. (102 mm) Octagon, 4 in. (102 mm) Square
HSC-224RA	4 in. (102 mm) Octagon, 4 in. (102 mm) Square

**HSC-224RA RELAY CONTACT TERMINAL STRIP**

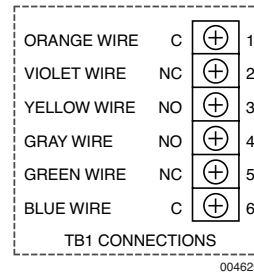

**Listings and Approvals\***

UL . . . . . S1383  
 ULC . . . . . CS463  
 California State Fire Marshal (CSFM) . . . . . 7272-0410:107  
 Factory Mutual (FM) . . . . . 1O5A1.AY  
 MEA . . . . . 284-91-E

\* Listings and Approvals are under HOCHIKI AMERICA CORPORATION

**Ordering Information**

Part No.	Description	Shipping Weight	
		lb	(kg)
427597	SLR-24H Photoelectric/ Heat Smoke Detector	1	(0.4)
427598	NS6-224 Base	0.5	(0.2)
427599	NS4-224 Base	0.5	(0.2)
417457	HSB-21 Base	0.5	(0.2)
416849	HSC-224RA Relay Base	0.5	(0.2)
415730	Test Magnet	0.5	(0.2)
405491	Punk Stick (Pack of 10)	0.5	(0.2)



## SLR-24 Photoelectric Smoke Detector (IQ-318/IQ-636X-2 (with FZM))

### Features

- Low profile, 1.8 in. (46 mm) high – with base
- 2 or 4 wire base compatibility, relay bases available
- Highly stable operation, RF/Transient protection
- Low standby current, 45 $\mu$ A at 24 VDC
- Two built-in power/sensitivity supervision/alarm LEDs
- Non-directional smoke chamber
- Vandal resistant security locking feature
- Built-in magnetic go/no go detector test feature
- Removable smoke labyrinth for cleaning or replacement
- Automatic Sensitivity window verification function meets outlined requirements in NFPA 72, Chapter 7, Inspection, Testing and Maintenance
- Backwards compatible with SLK and SIH detectors

### Applications

The SLR-24 Photoelectric Smoke Detectors are intended for use in commercial, industrial, and institutional buildings. The detectors are placed primarily in clean, indoor environments where early warning fire detection is required.

The detectors are used in combination with an AUTOPULSE Control System and an fire suppression system for automatic detection, alarm, equipment control, and fire suppression system release capabilities.

### Description

The SLR-24 photoelectric smoke detector utilizes two bicolor LEDs for indication of status. In a normal standby condition the LEDs flash Green every 3 seconds. When the detector senses that its sensitivity has drifted outside the UL listed sensitivity window the LEDs will flash Red every 3 seconds. When the detector senses smoke and goes into alarm the status LEDs will latch on Red.

The detector utilizes an infrared LED light source and silicon photo diode receiving element in the smoke chamber. In a normal standby condition, the receiving element receives no light from the pulsing LED light source. In the event of a fire, smoke enters the detector smoke chamber and light is reflected from the smoke particles to the receiving element. The light received is converted into an electronic signal.

Signals are processed and compared to a reference level, and when two consecutive signals exceeding the reference level are received within a specified period of time, the time delay circuit triggers the SCR switch to activate the alarm signal. The status LEDs light continuously during the alarm period.

### DIMENSIONS – NS6-224 BASE

- ▶ TO 4 IN. (102 mm) SQUARE OR
- ▶ 4 IN. (102 mm) OCTAGON

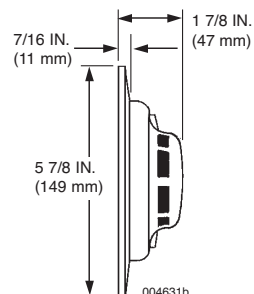
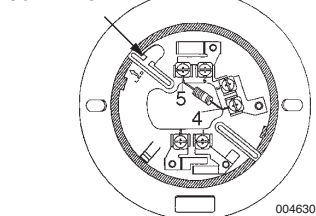

### DIMENSIONS – NS4-224 BASE

- ▶ TO 3 IN. (76 mm)

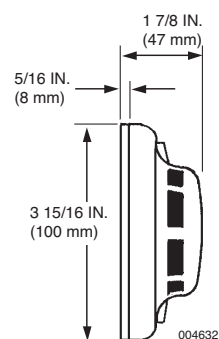
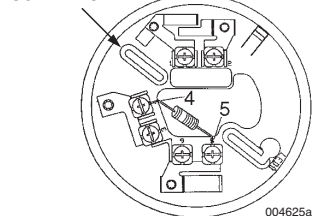

### DIMENSIONS – HSB-21 BASE

- ▶ TO 4 IN. (102 mm) SQUARE OUTLET BOX

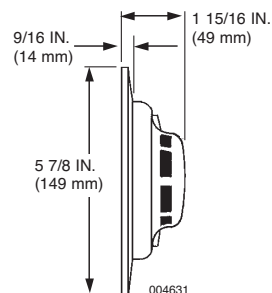
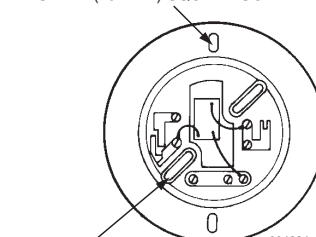

- ▶ TO 3 IN. (76 mm) OR 4 IN. (102 mm)

### DIMENSIONS – HSC-224RA BASE

- ▶ TO 4 IN. (102 mm) SQUARE OR
- ▶ 4 IN. (102 mm) OCTAGON

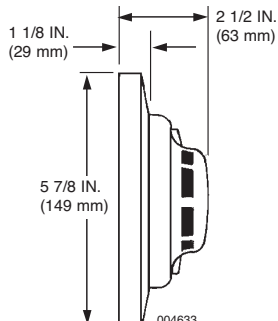
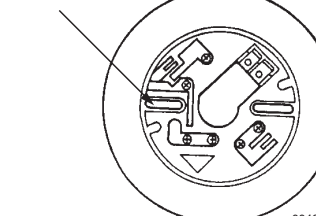









(Page Left Intentionally Blank)





## CAB-4 Cabinets (IQ-636X-2)

### General

- ▶ All cabinets for the AUTOPULSE IQ-636X-2 fire alarm control panel are fabricated from 16-gauge steel. The cabinet assembly consists of two basic parts: a backbox and a locking door. Cabinets are red with LEXAN® windows.
- The key-locked door is provided with a pin-type hinge, two keys and the necessary hardware to mount the door to the backbox.
- The backbox has been engineered to provide ease-of-entry for the installer. Knockouts are positioned at numerous points to aid the installer in bringing a conduit into the enclosure.
- Right- or left-hand hinges, selectable in the field. Door opens 180°.
- Cabinets are arranged in four sizes, A (one tier) through D (four tiers).
- ▶ A trim ring option is available for semi-flush mounting.

### Agency Listings and Approvals

UL Listed . . . . .	S635
U.S. Coast Guard . . . . .	161.002/42/1
ULC Listed . . . . .	S635/CS118
FM . . . . .	Approved
California State Fire Marshal . . . . .	7165-0028:214 7170-0028:216
MEA (NYC) . . . . .	17-96-E Vol. VI; 128-07-E Vol. 5

DIMENSIONAL DRAWINGS OF 'B,' 'C,' AND 'D' SIZED CABINETS ARE PROVIDED ON PAGE 2

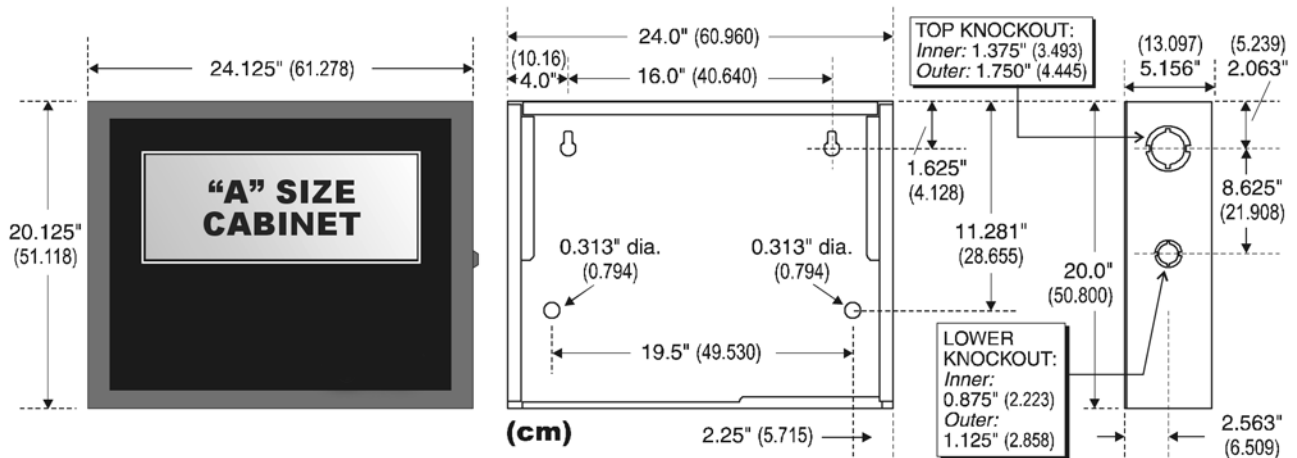

007290

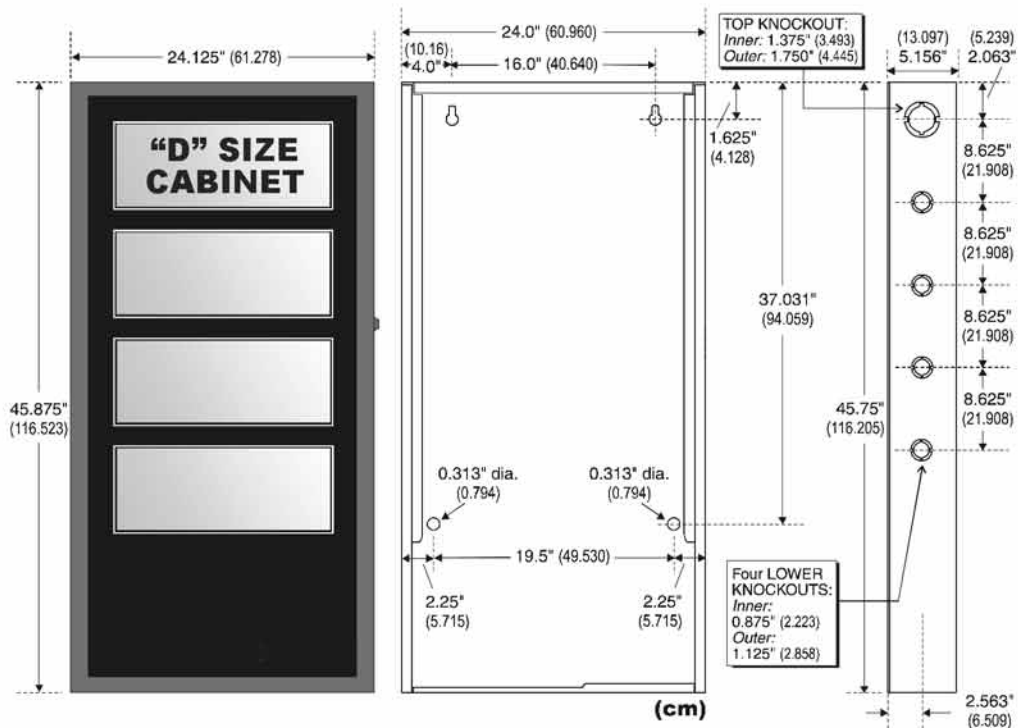
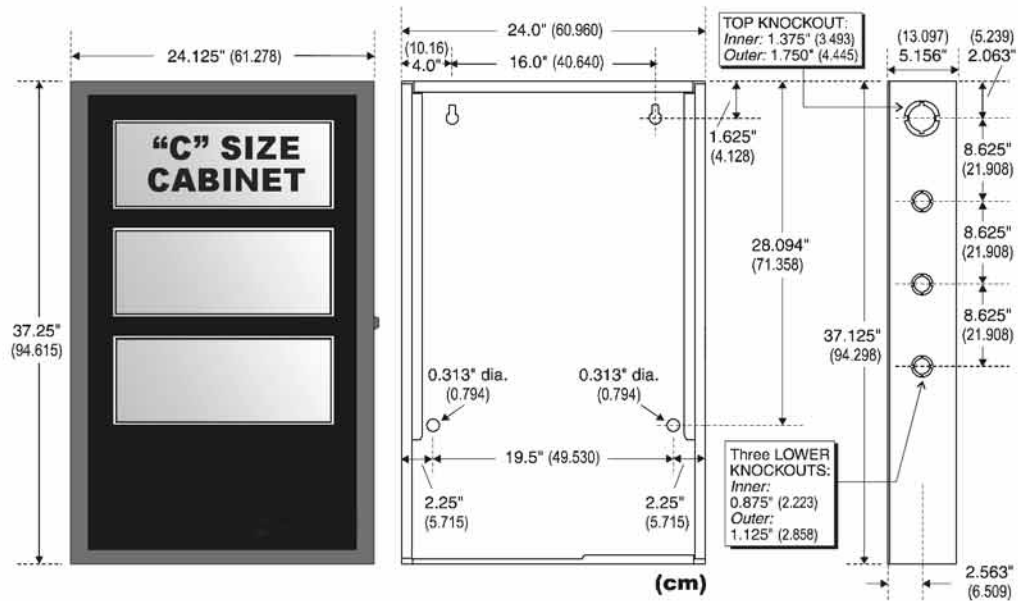
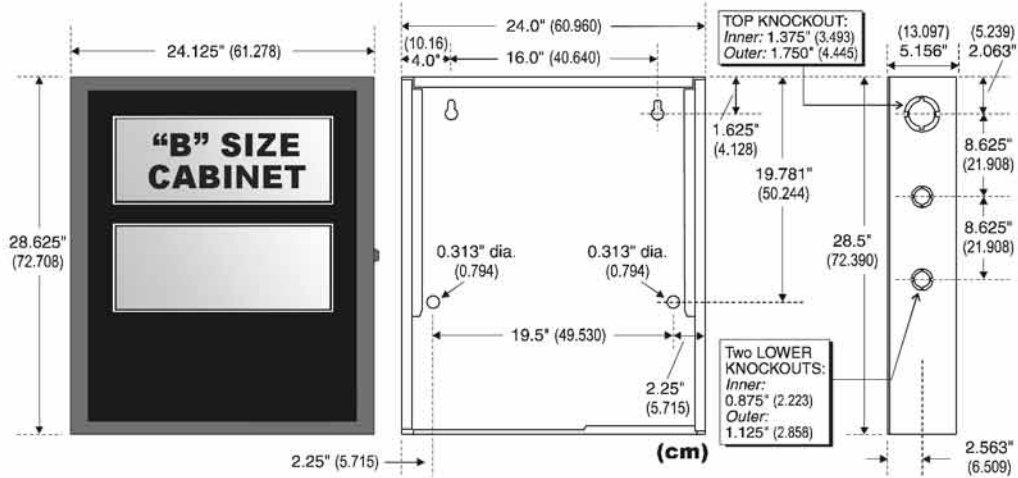

## Ordering Information

A complete cabinet assembly consists of: a door, a backbox, an optional battery plate, and an optional semi-flush trim ring. For each cabinet required, order one "DR" door and one "SBB" backbox. The BP-4 battery plate is required for each cabinet assembly that mounts batteries and/or a power supply in the lower position of the cabinet. The optional trim ring is an attractive "picture frame"-style black metal ring.

### One Tier, "A" Size:

Part No. 435598 DR-A4R: Door assembly, LEXAN window, one tier, RED. (ULC Part No. 437039)

Part No. 433526 SBB-A4R: Backbox assembly, one tier, RED. (ULC Part No. 437043)

Part No. 433534 TR-A4: Accessory semi-flush-mount trim ring, one tier (opening 24.062 in. (611 mm) W x 20.062 in. (510 mm) H), BLACK. **Note:** Black trim rings are used with red cabinets. (ULC Part No. 437047)

Part No. 432795 BP-4: Battery panel. Used to cover battery and power supply when lower position is used in backbox.

### Two Tiers, "B" Size:

Part No. 435599 DR-B4R: Door assembly, LEXAN window, two tiers, RED. (ULC Part No. 437040)

Part No. 433527 SBB-B4R: Backbox assembly, two tiers, RED. (ULC Part No. 437044)

Part No. 433535 TR-B4: Accessory semi-flush-mount trim ring, two tiers (opening 24.062 in. (611 mm) W x 28.562 in. (725 mm) H), BLACK. **Note:** Black trim rings are used with red cabinets. (ULC Part No. 437048)

Part No. 432795 BP-4: Battery panel. Used to cover battery and power supply when lower position is used in backbox.

### Three Tiers, "C" Size:

Part No. 435600 DR-C4R: Door assembly, LEXAN window, three tiers, RED. (ULC Part No. 437041)

Part No. 433529 SBB-C4R: Backbox assembly, three tiers, RED. (ULC Part No. 437045)

Part No. 433589 TR-C4: Accessory semi-flush-mount trim ring, three tiers (opening 24.062 in. (611 mm) W x 37.187 in. (945 mm) H), BLACK. **Note:** Black trim rings are used with red cabinets. (ULC Part No. 437049)

Part No. 432795 BP-4: Battery panel. Used to cover battery and power supply when lower position is used in backbox.

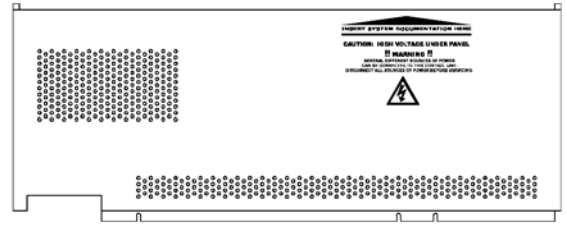

THE BP-4 BATTERY DRESS PANEL COVERS THE MAIN POWER SUPPLY AND THE BATTERIES IN THE CABINET.

ONLY ONE BP-4 IS REQUIRED PER CABINET.

### Four Tiers, "D" Size:

Part No. 435601 DR-D4R: Door assembly, LEXAN window, four tiers, RED. (ULC Part No. 437042)

Part No. 433532 SBB-D4R: Backbox assembly, four tiers, RED. (ULC Part No. 437046)

Part No. 433590 TR-D4: Accessory semi-flush-mount trim ring, four tiers (opening 24.062 in. (611 mm) W x 45.812 in. (1164 mm) H), BLACK. **Note:** Black trim rings are used with red cabinets. (ULC Part No. 437050)

Part No. 432795 BP-4: Battery panel. Used to cover battery and power supply when lower position is used in backbox.

### Accessories:

Part No. 433521 DP-1B: Blank dress panel, covers one CAB-4 tier, BLACK. (ULC Part No. 437058)

### Agency Listings and Approvals

See the first page of this data sheet for listing agencies and file numbers. These listings and approvals apply to the CAB-4 Series Cabinets. In some cases, certain modules or applications may not be listed by certain approval agencies, or listing may be in process. Consult factory for latest listing status.

LEXAN® is a registered trademark of GE Plastics, a subsidiary of General Electric Company.







## LEM-320 Loop Expander Module (IQ-636X-2)

### General

The LEM-320 module is used to expand the AUTOPULSE IQ-636X-2 to a second signaling line circuit (SLC) loop.

### Features

- Up to 12,500 ft (3,810 m) on a Class B (Style 4) SLC loop (twisted unshielded)
- Built-in degraded mode increases survivability
- Very simple installation — plug-in style

### Specifications

- **Voltage:** 24 VDC nominal, 27.6 VDC maximum
- **Maximum loop length:** The maximum wiring distance of an SLC using 12 AWG (3.1 mm<sup>2</sup>) twisted-pair wire is 12,500 ft (3810 m) per channel. For a twisted unshielded pair, 12 AWG (3.1 mm<sup>2</sup>) to 18 AWG (0.78 mm<sup>2</sup>).  
Distance with 12 AWG: 12,500 ft (3,810 m)  
Distance with 14 AWG: 8,000 ft (2,438 m)  
Distance with 16 AWG: 4,875 ft (1,486 m)  
Distance with 18 AWG: 3,225 ft (983 m)  
50 ohms maximum per length of Style 6 and 7 loops  
50 ohms maximum per branch for Style 4 loop
- **Maximum current:** for LEM-320: 100 mA; for single SLC loop: 400 mA maximum\*  
**\*Note:** Maximum short circuit — circuit will shut down until short-circuit condition is corrected.
- **Maximum resistance:** 50 ohms (supervised and power-limited)
- **Temperature and humidity ranges:** This system meets NFPA requirements for operation at 32 °F to 120 °F (0 °C to 49 °C); and at a relative humidity (noncondensing) of 85% at 86 °F (30 °C) per NFPA, and 93% ± 2% at 89.6 °F ± 1.1 °F (32 °C ± 2 °C) per ULC. However, the useful life of the system's standby batteries and the electronic components may be adversely affected by extreme temperature ranges and humidity. Therefore, it is recommended that this system and all peripherals be installed in an environment with a nominal room temperature of 60 °F to 80 °F (15 °C to 27 °C).



007219

### Listings and Approvals

UL Listed	..... S635
ULC Listed	..... S635/CS118
California State Fire Marshal	..... 7170-0028.26
FM	..... Approved
MEA (NYC)	..... 128-07-E Vol. 5
City of Denver	
Hong Kong	

### Product Line Information

LEM-320 Loop Expander Module. Expands AUTOPULSE IQ-636X-2 to two loops.

## Installation

Mount LEM-320 module within the cabinet with the CPU; standard mounting locations are adjacent to the panel or in the row immediately below it. See panel installation manuals for instructions on installing modules and/or option boards in the chassis.

After the LEM-320 module is mounted in the cabinet, connect the SLC loop to TB1. Up to 159 detectors and 159 modules can be connected to the SLC loop. FlashScan® devices can operate in either FlashScan or CLIP mode, but CLIP devices in CLIP mode must be set to address 99 or lower.

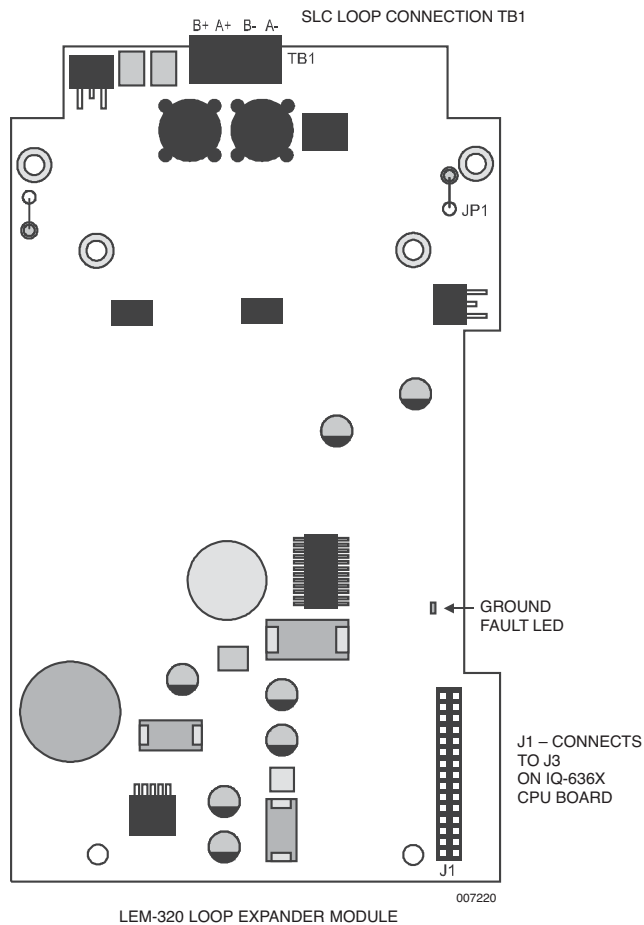

## Ordering Information

Part No.	Description	Shipping Weight	
		lb	(kg)
433508	LEM-320 Loop Expander Module	1	(0.45)
437062	LEM-320 Loop Expander Module (ULC)	1	(0.45)

FlashScan is a registered trademark of Honeywell International.

# Detection and Control Components



## New Series Photoelectric and Photoelectric/ Thermal Smoke Detectors (542R/542D)

### Features

- Plug-in detector line – mounting base included.
- Large wire-entry port.
- In-line terminals with SEMS screws.
- Mounts to octagonal and single-gang backboxes, 4 in. (102 mm) square backboxes, or directly to ceiling.
- ▶ Stop-Drop 'N Lock™ attachment to base.
- Removable detector cover and chamber for easy cleaning.
- Built-in remote maintenance signaling.
- Drift compensation and smoothing algorithms.
- Simplified sensitivity measurement.
- Wide-angle, dual-color LED indication.
- Loop testing via “EZ Walk” feature.
- Built-in test switch.

### Description

New Series photoelectric and photoelectric/ thermal smoke detectors represent a significant advancement in conventional detection, incorporating three key features: installation ease, intelligence, and instant inspection.

**Installation ease:** The New Series redefines installation ease with its plug-in design. This allows an installer to pre-wire the bases included with the heads. The large wire-entry port and in-line terminals provide ample room for neatly routing the wiring inside the base. The base accommodates a variety of backbox mounting methods, as well as direct mounting with drywall anchors. To complete the installation, New Series heads plug into the base with a simple Stop-Drop 'N Lock action.

**Intelligence:** New Series detectors offer a number of intelligent features to simplify testing and maintenance. Drift compensation and smoothing algorithms, to minimize nuisance alarms, are standard in the New Series. When connected to an AUTOPULSE 542R/542D Control Panel, two-wire New Series detectors are capable of generating a remote maintenance signal when they need cleaning. This signal is indicated by LEDs located at the AUTOPULSE 542R/542D Control Panel.

**Instant inspection:** The New Series provides wide-angle red and green LED indicators for instant inspection of detector condition. The LEDs indicate: normal standby, out-of-sensitivity, alarm, or freeze trouble conditions. The “EZ Walk” loop test feature is available on two-wire New Series detectors when connected to an AUTOPULSE 542R/542D Control Panel. The “EZ Walk” feature verifies the initiating loop wiring by providing LED status indication at each detector.



008037

### Physical Specifications

**Operating Temperature Range:** For models 2W-B and 4WB: 32 °F to 120 °F (0 °C to 49 °C); for thermal models 2WT-B and 4WT-B: 32 °F to 100 °F (0 °C to 38 °C).

**Storage Temperature Range:** –4 °F to +158 °F (–20 °C to +70 °C).

**Operating Humidity Range:** 10% – 95% RH, non-condensing.

**Thermal Sensor:** 135 °F (57 °C) fixed (models 2WT-B, 4WT-B).

**Freeze Trouble:** 41 °F (5 °C) (models 2WT-B and 4WT-B).

**Sensitivity:** 2.5%/ft (0.762%/meter) nominal.

**Input Terminals:** Utilize 14 to 22 AWG wire.

▶ **Dimensions (including base):** 5.3 in. (135 mm) diameter, 2.0 in. (51 mm) high.

**Weight:** 6.3 oz (178.6 grams).

▶ **Mounting Options:** 3.5 in. (89 mm) octagonal backbox; 4 in. (102 mm) octagonal backbox; single-gang backbox; 4 in. (102 mm) square backbox with a plaster ring; or direct mount to ceiling.

## Electrical Specifications

**Operating Voltage:** 12/24 V non-polarized nominal; 8.5 V minimum; 35 V maximum.

**Maximum Ripple Voltage:** 30% of nominal (peak to peak).

**Standby Current:** 50  $\mu$ A maximum average. Peak standby current: for two-wire models: 100  $\mu$ A; not applicable for four-wire models.

**Maximum Start-Up Capacitance:** For two-wire models: 0.1  $\mu$ F; not applicable for four-wire models.

**Latching Alarm:** Reset by momentary power interruption.

**Maximum Initial Start-Up Time:** For two-wire models: 45 seconds; for four-wire models: 15 seconds.

**Maximum Alarm Current:** For two-wire models: 130 mA limited by control panel; For four-wire models: 20 mA @ 12 V, 23 mA @ 24 V.

**Alarm Contact Ratings:** For four-wire models: 0.5 A @ 30 VAC/VDC; not applicable for two-wire models.

**Alarm Reset Voltage:** 2.5 V.

**Alarm Reset Time:** 0.3 seconds.

## Wiring Diagrams

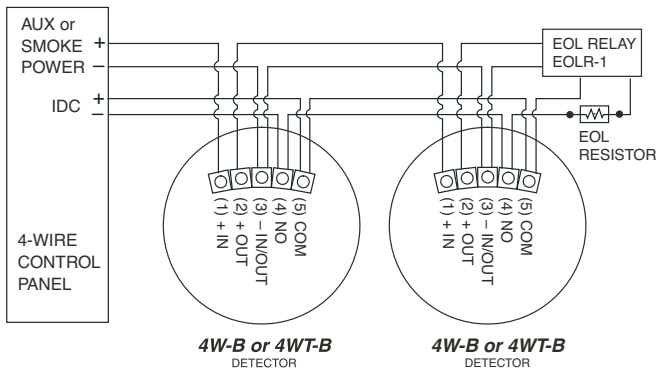
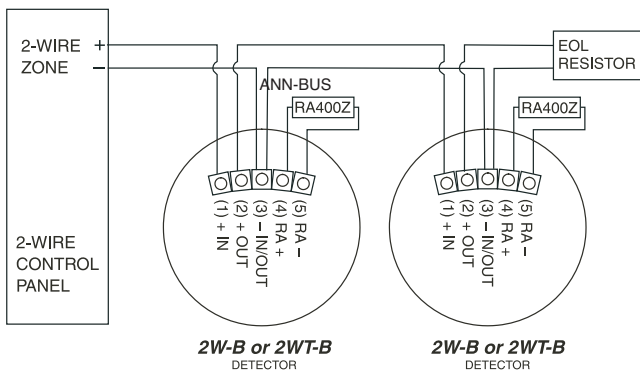

008038

LED Modes	Green LED	Red LED
Power Up	Blink every 10 seconds	Blink every 10 seconds
Normal (Standby)	Blink every 5 seconds	OFF
Out of Sensitivity	OFF	Blink every 5 seconds
Freeze Trouble	OFF	Blink every 10 seconds
Alarm	OFF	Solid ON
Power Up Sequence for LED Indication		
Condition		Duration
Initial LED Status Indication		80 Seconds
Initial LED Status Indication (if excessive electrical noise is present)		4 Minutes

## Agency Listings and Approvals

UL Listed . . . . . S911  
 FM . . . . . Approved  
 CSFM . . . . . 7272-1653:152  
 MEA . . . . . 290-01-E  
 Maryland State Fire Marshal . . . . . Permit No. 2093  
 ETL . . . . . Approved  
 USCG. . . . . 161.002/A42/1

## Ordering Information

Part No.	Description	Shipping Weight	
		lb	(kg)
435893	2W-B: Two-Wire Photoelectric Smoke Detector	1.5	(0.7)
435894	2WT-B: Two-Wire Photoelectric Smoke Detector with 135 °F (57 °C) Fixed Thermal Sensor	1.5	(0.7)
435895	4W-B: Four-Wire Photoelectric Smoke Detector	1.5	(0.7)
435896	4WT-B: Four-Wire Photoelectric Smoke Detector with 135 °F (57 °C) Fixed Thermal Sensor	1.5	(0.7)

Stop-Drop 'N Lock™ is a trademark of Honeywell International Inc.



## 2151 Photoelectric Smoke Detector (542R/542D)

### Features

- Unique optical sensing chamber
- Built-in signal processing
- 3.0% nominal sensitivity
- Removable cover for field cleaning
- Visible LED “blinks” in standby
- Sealed against dirt, insects, and back pressure
- Field metering of detector sensitivity
- Built-in magnetic test switch
- Low standby current
- Built-in tamper-resistant feature
- Designed for direct surface or electrical box mounting
- 360° Field viewing angle of the visual alarm LEDs
- Insect-resistant screening
- Easy plug-in of the head to base
- SEMS screws for easy wiring
- Air velocity up to 3000 feet per minute (914 meters per minute)

### Applications

Photoelectric detectors are recommended in areas where slow smoldering fires are likely to ignite. In areas where small combustion particles are usually present from fork-lift trucks, cooking stoves, etc., they are less likely than ionization detectors to produce false alarms. The detectors are used in combination with an AUTOPULSE Control System and an fire suppression system for automatic detection, alarm, equipment control, and fire suppression system release capabilities.

### Description

The 2151 photoelectric smoke detector contains a unique optical sensing chamber designed to sense the presence of smoke particles produced by a wide range of combustion sources and meet the performance criteria designed by UL 268. An integrated circuit incorporates signal processing to reduce false alarms and sample/hold circuitry to provide easy field metering of sensitivity.

The 2151 photoelectric detector incorporates the light scatter principle within its sensing chamber and solid-state circuitry allowing it to react to either smoldering or flaming fires.

The high-impedance circuitry of the detector allows a single loop to power multiple detectors with very low power consumption. Two externally-mounted LED indicators are provided which will blink as long as the detector is powered and will light steadily when the detector is in alarm.

### Technical Information

Stand-by Current: . . . . . 85 microamps  
 Sensitivity: . . . . . 3.0% nominal  
 Weight: . . . . . 0.5 lb (277 g)  
 Size: . . . . . 1.7 in. high x 4.0 in. diameter  
 (84 mm x 102 mm)  
 Construction: . . . . . Flame retardant white thermo plastic  
 Temperature: . . . . . 32 °F to 120 °F (0 °C to 49 °C)  
 Humidity Range: . . . . . 10-93% RH (non-condensing)  
 Maximum Air Velocity: . . . . . 3000 ft per minute  
 (15 m per second)

### 2151 PHOTOELECTRIC SMOKE DETECTOR WITH BASE

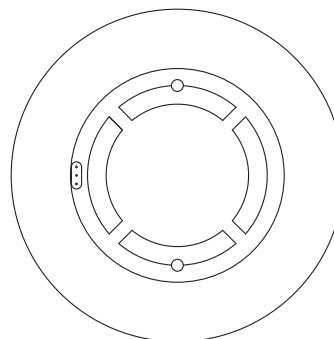
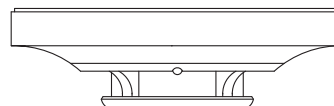

007353

### B110LP OPTIONAL NFPA CLASS “A” WIRING

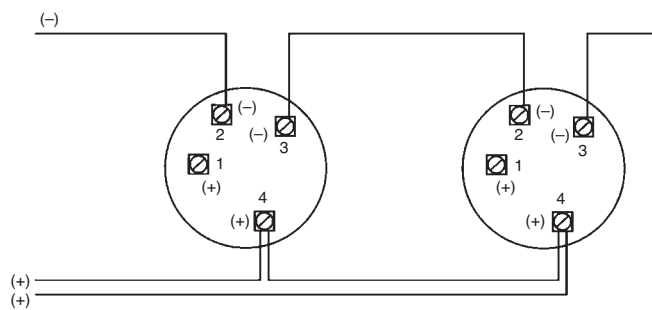

007350

## Technical Information (Continued)

Base Model	Loop Type	Current Limit Resistor	Contact Type	Standby Voltage	Current Draw on Alarm
B110LP	2-Wire	No	--	12-24 VDC	10-100 mA*
B401	2-Wire	No	--	12-24 VDC	10-100 mA*
B401B	2-Wire	No	--	8.5-35 VDC	10-100 mA*
B401BR-750	2-Wire	Yes	--	17-32 VDC	10-39 mA
B402B	2/4 Wire	Yes	Form A/C	17-32 VDC	14-39 mA

\* Limited by control unit

### Detector Base/Control Unit Compatibility

Detector Base (Part No.)	AUTOPULSE 542R, 542D	AUTOPULSE IQ-318, IQ-636X-2 FZM-1
B110LP (430025)	Yes	Yes
B401 (423026)	Yes	Yes
B401B (417996)	Yes	Yes
B401BR-750 (78997)	No	No
B402B (79011)	4-wire only	4-wire only

### B110LP BASE WIRING DIAGRAM

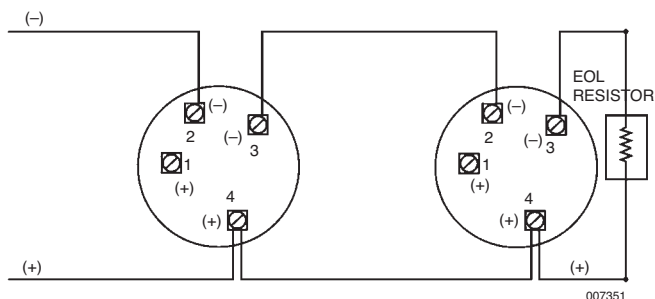

### Listings and Approvals\*

UL..... S911  
 California State Fire Marshal (CSFM)..... 7271-1209:159  
 Factory Mutual (FM)..... Approved  
 MEA..... 205-94-E

\* Listings and Approvals are under SYSTEM SENSOR

### Ordering Information

Part No.	Description	Shipping Weight	
		lb	(kg)
430023	2151, Photoelectric Detector	1	(0.4)
430025	B110LP Standard Base	0.5	(0.2)
430026	B401 4 in. Dia Base	0.5	(0.2)
428138	F110 Trim Ring, Low Profile	0.5	(0.2)
417675	M02-04 Test Magnet	0.5	(0.2)
417699	EOL, Power Supervision Relay	1	(0.4)

### Mounting Guidelines

The detector bases are designed for surface mounting. The detector head can be inserted or removed from the base without disrupting the wiring connections.

- ▶ All detector bases can be mounted to a 3 1/2 in. (89 mm) octagon, 4 in. (102 mm) octagon, or a 4 in. (102 mm) square outlet box.



# Detection and Control Components



## ANN-80 80 Character LCD Serial Annunciator (542R/542D)

### Features

- Backlit 80-character LCD display (20 characters x 4 lines)
- Mimics all display information from the host panel.
- Control switches for System Acknowledge, Signal Silence, Drill, and Reset.
- Control switches can be independently enabled or disabled at the AUTOPULSE 542R/542D Control Panel.
- Keyswitch enables/disables control switches and mechanically locks annunciator enclosure
- Keyswitch can be enabled or disabled at the AUTOPULSE 542R/542D Control Panel.
- Enclosure supervised for tamper.
- System status LEDs for AC Power, Alarm, Trouble, Supervisory, and Alarm Silence.
- Local sounder can be enabled or disabled at the AUTOPULSE 542R/542D Control Panel.
- ANN-80 connects to the ANN-BUS terminal on the AUTOPULSE 542R/542D Control Panel and requires minimal panel programming.
- Displays device type identifiers, individual point alarm, trouble, supervisory, zone, and custom alpha labels.
- Time-and date display field.
- Aesthetically pleasing design constructed of durable Lexan.
- Surface mount directly to wall or to single, double, or 4 in. (102 mm) square electrical box.
- ▶ Semi-flush mount to single, double, or 4 in. (102 mm) square electrical box.
- Can be remotely located up to 6,000 ft (1,800 m) from the panel.
- Backlight turns off during AC loss to conserve battery power but will turn back on if an alarm condition occurs.
- May be powered by 24 VDC from the host AUTOPULSE 542R/542D Control Panel or by remote power supply (requires 24 VDC).
- Up to eight (8) ANN-80s can be connected on the ANN-BUS.



008031

### Description

The ANN-80 Annunciator is a compact, backlit, 80-character LCD fire annunciator that mimics the AUTOPULSE 542R/542D Control Panel display. It provides system status indicators for AC Power, Alarm, Trouble, Supervisory, and Alarm Silenced conditions. The ANN-80 and the AUTOPULSE 542R/542D Control Panel communicate over a two-wire serial interface employing the ANN-BUS communication format. Connected devices are powered, via two additional wires, by either the host AUTOPULSE 542R/542D Control Panel or a remote UL-listed, filtered power supply.

The ANN-80 displays English-language text of system point information including device type, zone, trouble or supervisory status, as well as any custom alpha labels programmed into the control panel. It includes control switches for remote control of critical system functions. (A keyswitch prevents unauthorized operation of the control switches).

Up to eight (8) ANN-80s may be connected to the ANN-BUS of the AUTOPULSE 542R/542D Control Panel. Minimal programming is required, which saves time during system commissioning.

The ANN-BUS can be powered by an auxiliary power supply when the maximum number of ANN-BUS devices exceeds the ANN-BUS power requirements. See the AUTOPULSE 542R/542D manual for more information.

Each ANN-BUS device requires a unique address (ID Number) in order to communicate with the AUTOPULSE 542R/542D Control Panel. A maximum of eight (8) devices can be connected to the AUTOPULSE 542R/542D Control Panel ANN-BUS communication circuit. See the AUTOPULSE 542R/542D manual for more information.

### Controls and Indicators

- AC Power
- Alarm
- Trouble
- Supervisory
- Alarm Silenced

**Specifications**

- **Operating voltage range:** 18 VDC to 28 VDC
- **Current consumption @ 24 VDC nominal** (filtered and non-resettable): 40 mA maximum.
- **Ambient temperature:** 32 °F to 120 °F (0 °C to 49 °C).
- **Relative humidity:** 93% ± 2% RH (non-condensing) at 90 °F ± 3 °F (32 °C ± 2 °C).
- ▶ • 5 3/8 in. (137 mm) high x 6 7/8 in. (175 mm) wide x 1 3/8 in. (35 mm) deep
- For use indoors in a dry location.
- All connections are power-limited and supervised.

**Wiring Requirements**

The ANN-80 connects to the AUTOPULSE 542R/542D Control Panel ANN-BUS communications circuit. To determine the type of wire and the maximum wiring distance that can be used with AUTOPULSE 542R/542D Control Panel ANN-BUS accessory modules, it is necessary to calculate the total worst case current draw for all modules on a single 4-conductor bus. The total worst case current draw is calculated by adding the individual worst case currents for each module.

**Note:** For total worst case current draw on a single ANN-BUS, refer to the AUTOPULSE 542R/542D manual.

After calculating the total worst case current draw, the table below specifies the maximum distance the modules can be located from the AUTOPULSE 542R/542D Control Panel on a single wire run. The table ensures 6.0 volts of line drop maximum. In general, the wire length is limited by resistance, but for heavier wire gauges, capacitance is the limiting factor.

These cases are marked in the chart with an asterisk (\*). Maximum length can never be more than 6,000 ft (1,800 m), regardless of gauge used. See table below.

A 14 to 18 AWG (0.75 – 2.08 mm<sup>2</sup>) wire for 24 VDC power circuit is acceptable. All connections must be power-limited and supervised. A maximum of eight (8) ANN-80 modules may be connected to this circuit.

**ANN-80 Wiring to AUTOPULSE 542R/542D CONTROL PANEL**

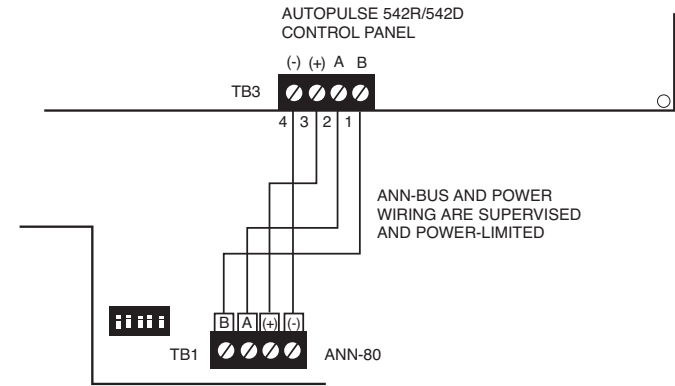

008032

**Agency Listings and Approvals**

- UL . . . . . S635
- FM . . . . . Approved
- CSFM . . . . . 7165-0595:118

**Ordering Information**

Part No.	Description	Shipping Weight	
		lb	(kg)
435355	ANN-80 80 Character LCD Serial Annunciator	3	(1.4)

Communication Pair Wiring Distance: AUTOPULSE 542R/542D Control Panel to Last ANN-BUS Module				
Total Worst Case Current Draw (amps)	22 Gauge	18 Gauge	16 Gauge	14 Gauge
0.100	1,852 ft (565 m)	4,688 ft (1,429 m)	*6,000 ft (1,829 m)	*6,000 ft (1,829 m)
0.200	926 ft (282 m)	2,344 ft (715 m)	3,731 ft (1,137 m)	5,906 ft (1,800 m)
0.300	617 ft (188 m)	1,563 ft (476 m)	2,488 ft (758 m)	3,937 ft (1200 m)
0.400	463 ft (141 m)	1,172 ft (357 m)	1,866 ft (569 m)	2,953 ft (900 m)
0.500	370 ft (113 m)	938 ft (286 m)	1,493 ft (455 m)	2,362 ft (720 m)
0.600	309 ft (94 m)	781 ft (238 m)	1,244 ft (379 m)	1,969 ft (600 m)
0.700	265 ft (81 m)	670 ft (204 m)	1,066 ft (325 m)	1,687 ft (514 m)
0.800	231 ft (70 m)	586 ft (179 m)	933 ft (284 m)	1,476 ft (450 m)
0.900	206 ft (63 m)	521 ft (159 m)	829 ft (253 m)	1,312 ft (400 m)
1.000 (max.)	185 ft (56 m)	469 ft (143 m)	746 ft (227 m)	1,181 ft (360 m)



## ANN-LED Annunciator Module (542R/542D)

### Features

- Listed to UL Standard 864, 9th Edition.
- ANN-LED connects to the ANN-BUS terminal on the AUTOPULSE 542R/542D Control Panel and requires minimal programming.
- Mounts in the DP-51050LED Dress Panel or in a separate enclosure.
- Provides three (3) LEDs for each zone: Alarm, Trouble and Supervisory.
- Can be remotely located up to 6,000 ft (1,829 m) from the panel.
- May be powered by 24 VDC from the host AUTOPULSE 542R/542D Control Panel or by remote power supply (requires 24 VDC).
- Up to eight (8) ANN-BUS devices may be connected to the ANN-BUS of the AUTOPULSE 542R/542D Control Panel.

### Description

The ANN-LED annunciator module provides LED annunciation of general system faults and input zones/points when used with a compatible AUTOPULSE 542R/542D Control Panel. The ANN-LED module provides alarm (red), trouble (yellow) and supervisory (yellow) indication for up to ten (10) input zones or addressable points.

The ANN-LED is supplied standard with certain Canadian FACPs as required by ULC.

The ANN-LED and the AUTOPULSE 542R/542D Control Panel communicate over a two-wire serial interface employing the ANN-BUS communication format. An additional two wires are used for 24-volt DC power. A single four-conductor unshielded cable may be used for both power and data communications.

Up to eight (8) ANN-BUS devices may be connected to the ANN-BUS of the AUTOPULSE 542R/542D Control Panel.

ANN-BUS devices can be powered by an auxiliary power supply when available panel power is exceeded. See the AUTOPULSE 542R/542D manual for information.

Each ANN-BUS device requires a unique address (ID Number) in order to communicate with the AUTOPULSE 542R/542D Control Panel. A maximum of eight (8) devices can be connected to the AUTOPULSE 542R/542D Control Panel ANN-BUS communication circuit. See the AUTOPULSE 542R/542D manual for more information.

### Specifications

- Maximum ANN-BUS Voltage: 24 VDC
- Maximum Current: Alarm: 68 mA Standby: 28 mA
- Maximum wiring distance from AUTOPULSE 542R/542D Control Panel: 6,000 ft (1,829 m)
- Ambient Temperature: 32 °F to 120 °F (0 °C to 49 °C)

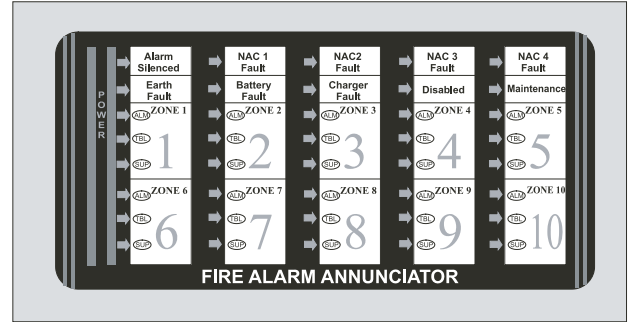

008035

- Relative Humidity: 93% ± 2% RH (non-condensing) at 90 °F ± 3 °F (32 °C ± 2 °C)
- For use indoors in a dry location

### Wire Requirements

The ANN-LED connects to the AUTOPULSE 542R/542D Control Panel ANN-BUS communications circuit. To determine the type of wire and the maximum wiring distance, calculate the total worst case current draw for all modules on a single 4-conductor bus. Use the table on the following page to determine the maximum distance the modules can be located from the AUTOPULSE 542R/542D Control Panel. In general, the wire length is limited by resistance, but for heavier wire gauges, capacitance is the limiting factor. These cases are marked in the chart with an asterisk (\*). Maximum length can never be more than 6,000 ft (1,800 m), regardless of gauge used.

**Note:** Refer to the AUTOPULSE 542R/542D manual for wiring details and printer settings.

### ANN-LED Connection to AUTOPULSE 542R/542D Control Panel

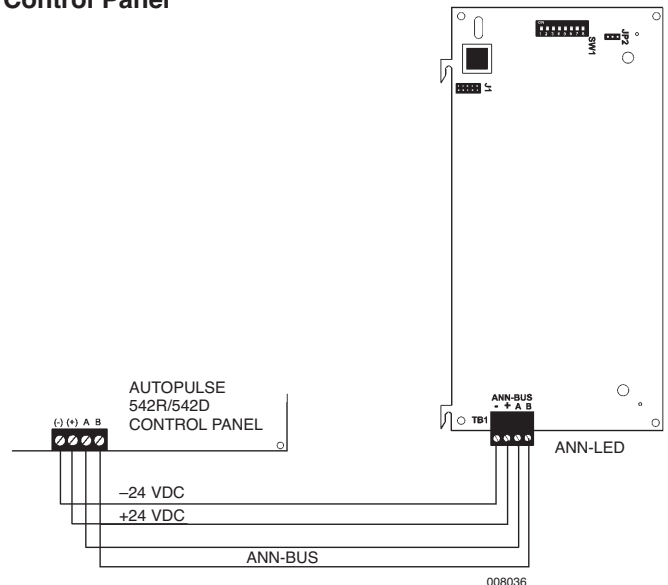

**Agency Listings and Approvals**

UL . . . . . S635  
 CSFM . . . . . 7165-0595:118  
 MEA . . . . . 333-07-E

**Ordering Information**

The ANN-LED module provides alarm (red), trouble (yellow) and supervisory (yellow) indication for up to ten (10) input zones or addressable points.

Part No.	Description	Shipping Weight	
		lb	(kg)
435359	ANN-LED Annunciator Module	3	(1.4)

Communication Pair Wiring Distance: AUTOPULSE 542R/542D Control Panel to Last ANN-BUS Module				
Total Worst Case Current Draw (amps)	22 Gauge	18 Gauge	16 Gauge	14 Gauge
0.100	1,852 ft (565 m)	4,688 ft (1,429 m)	*6,000 ft (1,829 m)	*6,000 ft (1.829 m)
0.200	926 ft (282 m)	2,344 ft (715 m)	3,731 ft (1,137 m)	5,906 ft (1,800 m)
0.300	617 ft (188 m)	1,563 ft (476 m)	2,488 ft (758 m)	3,937 ft (1200 m)
0.400	463 ft (141 m)	1,172 ft (357 m)	1,866 ft (569 m)	2,953 ft (900 m)
0.500	370 ft (113 m)	938 ft (286 m)	1,493 ft (455 m)	2,362 ft (720 m)
0.600	309 ft (94 m)	781 ft (238 m)	1,244 ft (379 m)	1,969 ft (600 m)
0.700	265 ft (81 m)	670 ft (204 m)	1,066 ft (325 m)	1,687 ft (514 m)
0.800	231 ft (70 m)	586 ft (179 m)	933 ft (284 m)	1,476 ft (450 m)
0.900	206 ft (63 m)	521 ft (159 m)	829 ft (253 m)	1,312 ft (400 m)
1.000 (max.)	185 ft (56 m)	469 ft (143 m)	746 ft (227 m)	1,181 ft (360 m)



## ANN-RLY Relay Module (542R/542D)

### Features

- ANN-RLY connects to the ANN-BUS terminal on the AUTOPULSE 542R/542D Control Panel and requires minimal programming.
- Provides ten (10) programmable Form-C relays.
- Ten (10) Form-C relays can be programmed for various functions; Alarm, Trouble, Supervisory, AC Loss, Waterflow Delay, Input Zones and Silenceable Alarm.
- May be powered by 24 VDC from the host AUTOPULSE 542R/542D Control Panel or by remote power supply (requires 24 VDC).
- Up to eight (8) ANN-BUS devices may be connected to the ANN-BUS of the AUTOPULSE 542R/542D Control Panel.
- Listed to UL Standard 864, 9th Edition.

### Description

The ANN-RLY relay module provides ten (10) programmable Form-C relays when used with a compatible AUTOPULSE 542R/542D Control Panel. The ANN-RLY module may be mounted inside the AUTOPULSE 542R/542D Control Panel main circuit board chassis or in the battery area of the enclosure using optional mounting bracket Part No. 435897. Reference Installation Instructions in the AUTOPULSE 542R/542D manual.

The ANN-RLY and the AUTOPULSE 542R/542D Control Panel communicate over a two-wire serial interface employing the ANN-BUS communication format. An additional two wires are used for 24-volt DC power. A single four-conductor unshielded cable may be used for both power and data communications.

Up to eight (8) ANN-BUS devices may be connected to the ANN-BUS of the AUTOPULSE 542R/542D Control Panel.

ANN-BUS devices can be powered by an auxiliary power supply when available panel power is exceeded. See the AUTOPULSE 542R/542D manual for information.

Each ANN-BUS device requires a unique address (ID Number) in order to communicate with the AUTOPULSE 542R/542D Control Panel. A maximum of eight (8) devices can be connected to the AUTOPULSE 542R/542D Control Panel ANN-BUS communication circuit. See the AUTOPULSE 542R/542D manual for more information.

### Specifications

- Maximum ANN-BUS Voltage: 24 VDC
- Maximum Current: – Alarm: 75 mA Standby: 15 mA
- Ambient Temperature: 32 °F to 120 °F (0 °C to 49 °C)
- Relative Humidity: 93% ± 2% RH (non-condensing) at 90 °F ± 3 °F (32 °C ± 2 °C)
- For use indoors in a dry location

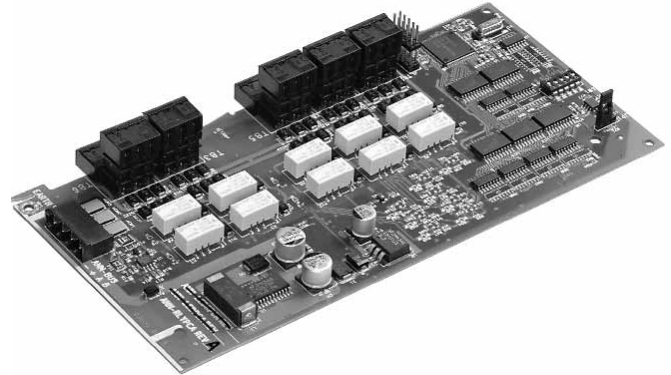

008033

- Connections to AUTOPULSE 542R/542D Control Panel are power-limited and supervised.
- Relay Contact Ratings: 2 Amps @ 30VDC (Resistive) 0.5 Amps @ 30VAC (Resistive)

### Wire Requirements

The ANN-RLY connects to the AUTOPULSE 542R/542D Control Panel ANN-BUS communications circuit. To determine the type of wire and the maximum wiring distance, calculate the total worst case current draw for all modules on a single 4-conductor bus. Use the table on the following page to determine the maximum distance the modules can be located from the AUTOPULSE 542R/542D Control Panel. In general, the wire length is limited by resistance, but for heavier wire gauges, capacitance is the limiting factor. These cases are marked in the chart with an asterisk (\*). Maximum length can never be more than 6,000 ft (1,800 m), regardless of gauge used.

**Note:** Refer to the AUTOPULSE 542R/542D manual for wiring details.

### ANN-RLY Wiring to AUTOPULSE 542R/542D Control Panel

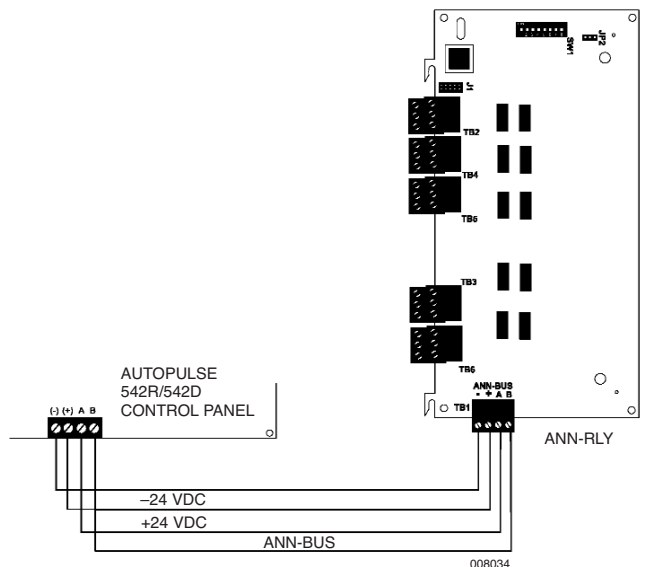

008034



**Agency Listings and Approvals**

UL . . . . . S635  
 CSFM . . . . . 7165-0595:118  
 MEA . . . . . 333-07-E

**Ordering Information**

- ANN-RLY Relay Module provides ten (10) programmable Form C relays.
- ANN-MBRLY Optional mounting bracket.

Part No.	Description	Shipping Weight	
		lb	(kg)
435358	ANN-RLY Relay Module	1	(0.5)
437021	ANN-RLY Relay Module (ULC)	1	(0.5)
435897	ANN-MBRLY Mounting Bracket	1	(0.5)

Communication Pair Wiring Distance: AUTOPULSE 542R/542D Control Panel to Last ANN-BUS Module				
Total Worst Case Current Draw (amps)	22 Gauge	18 Gauge	16 Gauge	14 Gauge
0.100	1,852 ft (565 m)	4,688 ft (1,429 m)	*6,000 ft (1,829 m)	*6,000 ft (1,829 m)
0.200	926 ft (282 m)	2,344 ft (715 m)	3,731 ft (1,137 m)	5,906 ft (1,800 m)
0.300	617 ft (188 m)	1,563 ft (476 m)	2,488 ft (758 m)	3,937 ft (1200 m)
0.400	463 ft (141 m)	1,172 ft (357 m)	1,866 ft (569 m)	2,953 ft (900 m)
0.500	370 ft (113 m)	938 ft (286 m)	1,493 ft (455 m)	2,362 ft (720 m)
0.600	309 ft (94 m)	781 ft (238 m)	1,244 ft (379 m)	1,969 ft (600 m)
0.700	265 ft (81 m)	670 ft (204 m)	1,066 ft (325 m)	1,687 ft (514 m)
0.800	231 ft (70 m)	586 ft (179 m)	933 ft (284 m)	1,476 ft (450 m)
0.900	206 ft (63 m)	521 ft (159 m)	829 ft (253 m)	1,312 ft (400 m)
1.000 (max.)	185 ft (56 m)	469 ft (143 m)	746 ft (227 m)	1,181 ft (360 m)





## 4XTM Transmitter Module (542R/542D)

### Description

The 4XTM Transmitter Module is an option for the AUTOPULSE control systems. The module provides a supervised output for local energy municipal box transmitter (for NFPA 72 Auxiliary Protective Signaling System) and alarm and trouble reverse polarity circuits (for NFPA 72 Remote Station Protective Signaling System). Also included is a DISABLE switch and disable trouble LED. A jumper option allows the reverse polarity circuit to open with a System Trouble condition if no alarm condition exists.

### Technical Information

For Local Energy Municipal Box service (NFPA 72 Auxiliary Protective Signaling System):

- Supervisory Current . . . . . 5.0 mA
- Trip Current . . . . . 0.35 amps (subtracted from indicating appliance power)
- Coil Voltage . . . . . 3.65 VDC
- Coil Resistance . . . . . 14.6 ohms
- Total wire resistance between unit and trip coil . . . 3 ohms

For Remote Station service (NFPA 72 Remote Station Protective Signaling System):

- Maximum Load for each circuit. . . . . 10 mA
- Reverse Polarity Output Voltage . . . . . 24 VDC

### Listings and Approvals\*

- UL . . . . . S635
- ULC . . . . . CS118, CS733
- Factory Mutual (FM). . . . . Approved
- MEA . . . . . 104-93-E Vol. VI
- CSFM . . . . . 7165-0028:245

\* Listings and Approvals are under NOTIFIER

### Ordering Information

Part No.	Description	Shipping Weight	
		lb	(kg)
435602	4XTM Transmitter Module	1	(0.5)

### 4XTM TRANSMITTER MODULE (POLARITIES SHOWN IN ACTIVATED POSITIONS)

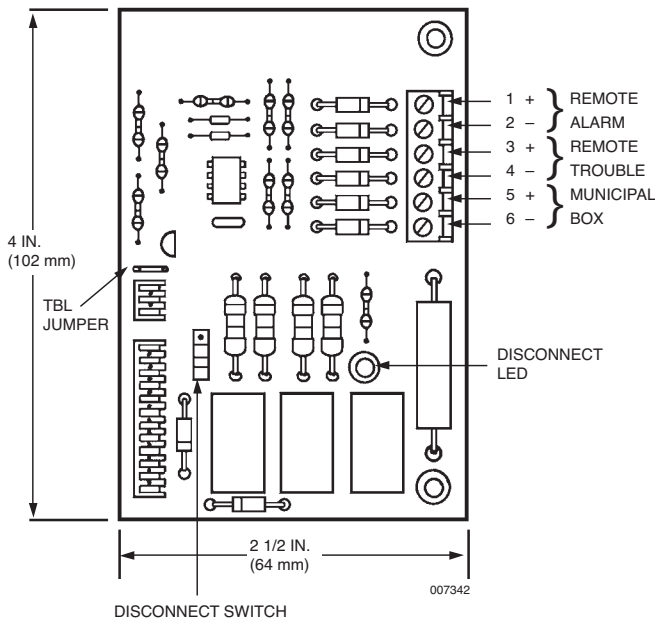





(Page Left Intentionally Blank)





(Page Left Intentionally Blank)





# Detection and Control Components



## LIFEalarm® Photoelectric Smoke Detectors with Smoke/Heat Detection (Z-10)

### Features

**LIFEalarm detection combines photoelectric detection with heat detection to provide a multi-mode detector with four detection mechanisms:\***

- Stable and reliable photoelectric smoke detection with built-in LIFEalarm sensitivity drift compensation
- Resettable, thermistor-based fixed temperature detection
- Resettable, thermistor-based rate-of-rise temperature detection
- A built-in analysis of photoelectric and thermal activity trending that provides fire detection with higher accuracy than either detection means used separately

### Functional chamber enclosure:

- Louvered design enhances smoke capture by directing flow to chamber
- Entrance areas are minimally visible when ceiling mounted

### Multi-function LED indicator:

- Indicates normal and alarm conditions
- Provides status during magnetic functional test

### Magnetically operated functional test:

- Initiates alarm and verifies performance
- Identifies general sensitivity status using detector LED pulses (normal, more sensitive, or less sensitive)
- With detectors categorized as normal or needing cleaning or other service, maintenance priorities can be more easily determined

### Available base options:

- Bases for 2-wire operation
- Auxiliary alarm relay output
- Remote alarm indicating LED output

### Optional remote LED alarm indicator

### Listings and Approvals

- UL Listed: S6648
- ULC Listed: S6648
- FM Approved: 3015976
- MEA (NYC): Approved
- CSFM: Approved

\* LIFEalarm detectors are protected by one or more of the following U.S. Patents: 5,155,468; 5,173,683; 5,400,014; 5,543,777; 5,710,541; 5,818,326; 6,195,011; D383,407; D388,352; D392,573.

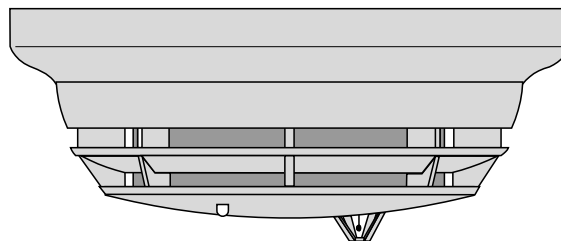

006622

**Detector (Part No. 430560) Mounted in Base**

### Description

LIFEalarm photoelectric smoke detectors combine photoelectric smoke detection technology and quick response thermistor-based heat detection technology into a sophisticated, intelligent detector that analyzes each of these activities and their combination to determine whether alarm conditions are present.

An onboard microprocessor provides four independent detection modes: photoelectric detection with sensitivity drift compensation, fixed temperature heat detection, rate-of-rise temperature heat detection, and photoelectric/heat trending analysis and alarm detection. If any of these alarm conditions are experienced, an alarm is initiated.

### Specifications

Voltage	15 to 32 VDC, from Control Panel IDC
Standby Current	100 $\mu$ A @ 24 VDC
Alarm Current, 2-Wire Operation	Up to 86 mA maximum, exact current is determined by alarm current limiting of connected IDC (initiating current device)
Auxiliary Relay Ratings	Refer to page 3 under Product Selection
Rate-of-Rise Temperature Alarm*	$\leq 20^\circ$ F/min ( $11^\circ$ C/min), <b>only effective at temperatures above <math>90^\circ</math> F (<math>32^\circ</math> C)</b>
Fixed Temperature Alarm	$135^\circ$ F ( $57^\circ$ C)
UL Listed Temp. Range*	$32^\circ$ F to $100^\circ$ F ( $0^\circ$ C to $38^\circ$ C)
Operating Temp. Range	$15^\circ$ F to $100^\circ$ F ( $-9^\circ$ C to $38^\circ$ C)
Smoke Obscuration Sensitivity	2.8%/ft Nominal, per UL268
UL Listed Temp. Range	$32^\circ$ to $100^\circ$ F ( $0^\circ$ to $38^\circ$ C)
Operating Temp. Range	$15^\circ$ to $122^\circ$ F ( $-9^\circ$ to $+50^\circ$ C)
Air Velocity Range	0-2000 ft/min (0-610 m/min)
Humidity Range	10% to 95% RH from $32^\circ$ to $122^\circ$ F ( $0^\circ$ to $50^\circ$ C)
Color	Frost White
Dimensions	4 7/8 in. Dia. x 2 in. H, mounted in base (124 mm x 51 mm)

\* Always locate this and all rate-of-rise heat detection devices away from extremes of temperature fluctuation.

## Description (Continued)

**Intelligent Data Evaluation.** Conventional smoke detectors will typically drift toward being too sensitive due to the accumulation of dust and dirt. With LIFEalarm analog detection, data from the photoelectric chamber is monitored and analyzed at the detector to provide a continuously shifting reference point.

**Drift Compensation.** The data evaluation and its shifting reference point provide a software filtering process that compensates for environmental factors (dust, dirt, etc.) and component aging, establishing an accurate reference for evaluating new activity. With this filtering, the resulting drift compensation provides a significant reduction in the probability of false or nuisance alarms caused by shifts in sensitivity – either up or down.

**Maintained Sensitivity and Dirty Status Indications.** With its onboard software compensation, the detector maintains its sensitivity much longer in the presence of dust and dirt accumulation. Additionally, it will determine when the dirt accumulation is approaching the limit of compensation, and will indicate that condition via its status indicator LED (see diagnostic information).

## Electronic Heat Detection

**Fixed Temperature Heat Detection** is provided with the addition of a fast response thermistor that causes an alarm at a fixed temperature of 135° F (57° C).

**Rate-of-Rise Heat Detection** occurs at  $\geq 20^{\circ}$  F/min ( $11^{\circ}$  C/min). To minimize the possibility of false alarms, rate-of-rise detection is correlated to the ambient temperature and is only in effect above 90° F (32° C).

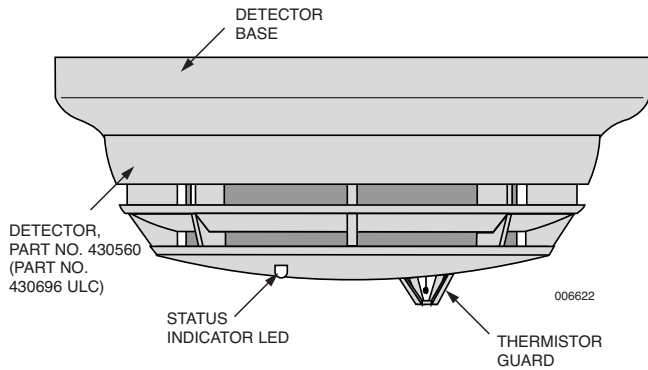

**Smoke Detector Package**

## Diagnostic Information

**Magnetic Test Information.** Status information is available by performing the magnetic test and observing the detector LED pulses. The LED will normally go directly into alarm with the magnetic test. If there is an off-normal condition, the LED pulses first to indicate the condition and then goes into alarm.

## Application Notes

**Observe heat detector location guidelines.** Ambient temperature operating range is 32° F to 100° F (0° C to 38° C). Temperature fluctuations should be below 6° F/min (3.3° C/min).

Detector locations should be determined only after careful consideration of the physical layout and contents of the area to be protected.

## Product Selection

Smoke Detector		
Part No.	Description	Compatibility
430560	LIFEalarm photoelectric detector with photoelectric/thermal detection	Compatible with detector bases: Part Nos. 430567 and 430569
Detector Bases		
Part No.	Description	Details
430567	<b>2-Wire Base</b> with connections for Remote Alarm LED Indicator	<ul style="list-style-type: none"> <li>• IDC and LED connections are screw terminals for in/out wiring, #18 to #14 AWG</li> </ul>
430569	<b>2-Wire Base</b> with Auxiliary Alarm Relay and connections for Remote LED Indicator  <b>Note:</b> Must be connected as the only device on the IDC to ensure relay operation.	<b>Relay Ratings, Dual Form "C," For Suppressed Loads:</b> <ul style="list-style-type: none"> <li>• Power limited, 1 A @ 28 VDC</li> <li>• Non-power limited, 1/2 A @ 120 VAC</li> </ul> <b>Wiring Connections (In/Out where required):</b> <ul style="list-style-type: none"> <li>• Relay contacts and IDC (-), color coded #18 AWG leads</li> <li>• IDC (+) and LED wiring, screw terminals for #18 to #14 AWG</li> </ul>
Detector Accessories		
Part No.	Description	Details
430572	Remote LED Indicator	<ul style="list-style-type: none"> <li>• Mounted on single gang stainless steel plate</li> </ul>

## Dimensions and Reference Information

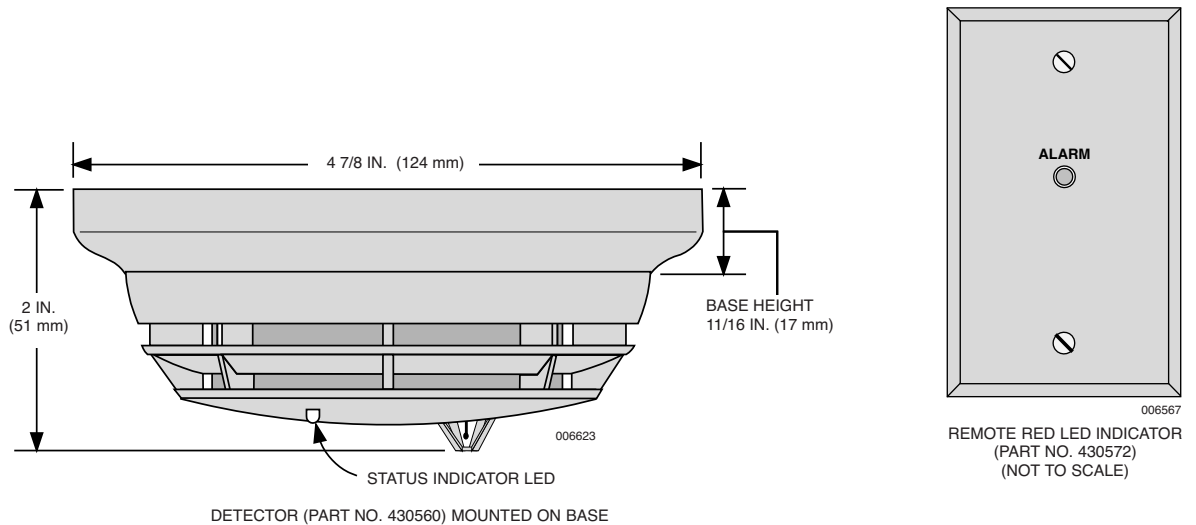

## Visible LED Status Indications

LED Indication		Status	
Flashes every 4 seconds		Circuit is <b>Normal</b> , power is applied	
Steady <b>On</b>		Detector is in <b>Alarm</b>	
LED Response to Magnetic Test *			
LED Indication	Alarm Response	Detector Status	Action Required
LED turns <b>ON</b>	Alarm is initiated	<b>Normal</b> , sensitivity is within compensation range	None
<b>Flashes quickly</b> , 6 times in 3 seconds, <b>then turns ON</b>	Alarm is initiated	<b>More sensitive</b> , out of normal compensation range	Cleaning or other <b>service is required</b>
<b>Flashes slowly</b> , 4 times in 8 seconds, <b>then turns ON</b>	Alarm is initiated	<b>Less sensitive</b> , out of normal compensation range	
	Alarm is <b>NOT</b> initiated	Detector is malfunctioning	<b>Service is required</b>

\* Testing requires placing a magnet at the designated location on the detector cover for 4 seconds.

## Mounting Information

### ELECTRICAL BOX REQUIREMENTS:

#### WITHOUT RELAY (BASES, PART NO. 430567):

4 IN. (102 mm) OCTAGONAL OR 4 IN. (102 mm) SQUARE, 1 1/2 IN. (38 mm) DEEP  
SINGLE GANG, 2 IN. (51 mm) DEEP

#### WITH RELAY (BASES, PART NO. 430569):

4 IN. (102 mm) OCTAGONAL, 1 1/2 IN. (38 mm) DEEP, WITH 1 1/2 IN. (38 mm) EXTENSION RING  
4 IN. (102 mm) SQUARE, 1 1/2 IN. (38 mm) DEEP, WITH 1 1/2 IN. (38 mm) EXTENSION RING

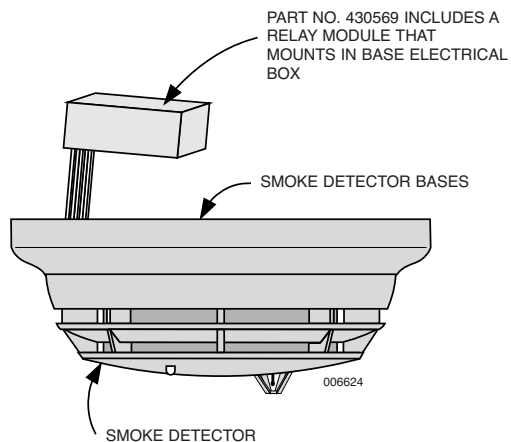
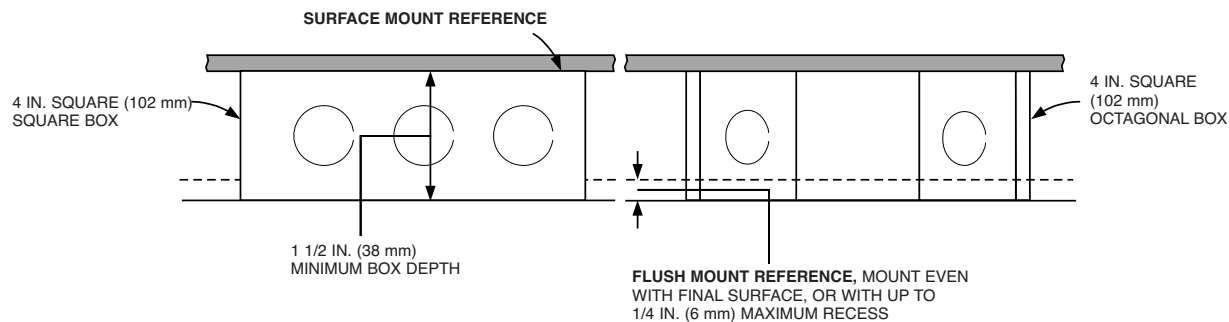

# Detection and Control Components



## LIFEalarm® Photoelectric Smoke Detectors For Two-Wire Bases (Z-10)

### Features

**LIFEalarm® Photoelectric smoke detector with on-board sensitivity drift compensation\***

#### Functional chamber enclosure:

- Louvered design enhances smoke capture by directing flow to chamber
- Entrance areas are minimally visible when ceiling mounted

**Multi-function indicator LED indicates normal and alarm conditions**

#### Magnetically operated functional test:

- Initiates alarm and verifies performance
- Identifies general sensitivity status using detector LED

#### Models available in two sensitivity settings:

- ▶ Part No. 430559, Standard Sensitivity, nominal 2.8%/ft obscuration
- Part No. 430562, Special Application Sensitivity, nominal 3.5%/ft obscuration

#### Available base options:

- Bases for 2-wire operation
- Auxiliary alarm relay output

#### Optional remote alarm indicating LED

### Description

LIFEalarm photoelectric detectors provide many of the proven analog sensing features for applications where detectors are connected to conventional 2-wire initiating device circuits (IDCs). Each detector has an on-board micro-processor that evaluates its photoelectric light scattering chamber activity and makes an intelligent decision based on light obscuration history as to whether an alarm condition is present.

LIFEalarm detectors are packaged in a patented housing that minimizes the visibility of the air intake louvers from the normal viewing locations while maintaining a high performance smoke capture ability. Bases are available for remote alarm LED indicator connections and auxiliary relay outputs.

\* LIFEalarm smoke detector operation is protected by one or more of the following U.S. Patents: 5,155,468; 5,173,683; 5,400,014; 5,543,777; 5,710,541; D383,407; D388,352; D392,573.

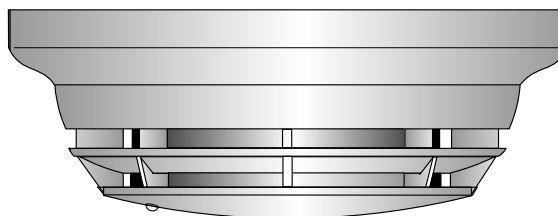

006564

**LIFEalarm Photoelectric Detector Mounted in Base**

### Listings and Approvals

- UL Listed: S6648
- ULC Listed: S6648
- FM Approved: 3015976
- CSFM: Approved
- MEA (NYC): Approved

### Specifications

Voltage	15 to 32 VDC, from Control Panel IDC
Standby Current	100 $\mu$ A @ 24 VDC
Alarm Current, 2-Wire Operation	Up to 86 mA maximum, exact current is determined by alarm current limiting of connected IDC
Auxiliary Relay Ratings	Refer to page 2 under Product Selection
Air Velocity Range	0-2000 ft/min (0-610 m/min)
UL Listed Temp. Range	32° to 100 °F (0° to 38 °C)
Operating Temp. Range	15° to 122 °F (-9° to + 50 °C)
Humidity Range	10% to 95% RH from 32° to 122° F (0° to 50 °C) non-condensing
Color	Frost White
Dimensions	4 7/8 in. Dia. x 1 7/8 in. H, mounted in base (124 mm x 48 mm)

## Smoke Detector Features

**Intelligent Data Evaluation.** Conventional smoke detectors will typically drift toward being too sensitive due to the accumulation of dust and dirt. With analog detection, data from the photoelectric chamber is monitored and analyzed at the detector to provide a continuously shifting reference point.

**Drift Compensation.** The data evaluation and its shifting reference point provide a software filtering process that compensates for environmental factors (dust, dirt, etc.) and component aging, establishing an accurate reference for evaluating new activity. With this filtering, the resulting drift compensation provides a significant reduction in the probability of false or nuisance alarms caused by shifts in sensitivity – either up or down.

**Magnetic Test Information.** Status information is available by performing the magnetic test and observing the detector LED pulses. The LED will normally go directly into alarm with the magnetic test. If there is an off-normal condition, the LED pulses first to indicate the condition and then goes into alarm.

## Application Reference

**Detector Locations.** Locations should be determined only after careful consideration of the physical layout and contents of the area to be protected.

For further detailed installation information, refer to Detectors, Sensors, and Bases Application Manual (Part No. 431424).

**Sensitivity Selection.** The standard sensitivity detector (Part No. 430559) is recommended for most applications. When a special application for a reduced sensitivity detector is required (Part No. 430562) should be considered.

## Product Selection

Smoke Detectors			
Part No.	Description	Nominal Sensitivity	Compatibility
430559	LIFEalarm Photoelectric Detector	2.8%/ft (standard)	Compatible with detector bases: Part Nos. 430567 and 430569
430562		3.5%/ft	
Compatible Bases			
Part No.	Description	Details	
430567	<b>2-Wire Base</b> with connections for Remote Alarm LED Indicator	<ul style="list-style-type: none"> <li>IDC and LED connections are screw terminals for in/out wiring, 18 to 14 AWG</li> </ul>	
430569	<b>2-Wire Base with Auxiliary Alarm Relay</b> & connections for Remote LED Indicator <b>Note:</b> Must be connected as the only device on the IDC to ensure relay operation.	<b>Relay Ratings, Dual Form "C", For Suppressed Loads:</b> <ul style="list-style-type: none"> <li>Power limited, 1 A @ 28 VDC</li> <li>Non-power limited, 1/2 A @ 120 VAC</li> </ul>	
430570	<b>2-Wire Base with Remote LED Indicator</b>	<b>Wiring Connections (In/Out where required):</b> <ul style="list-style-type: none"> <li>Relay contacts and IDC (–), color coded 18 AWG leads</li> <li>IDC (+) and LED wiring, screw terminals for 18 to 14 AWG</li> </ul>	
Detector Accessories			
Part No.	Description	Details	
430572	Remote LED Indicator	<ul style="list-style-type: none"> <li>Mounted on single gang stainless steel plate</li> </ul>	

### Detector Status LED Indications

LED Indication	Status		
Pulses approximately every 4 seconds	Normal		
Steady On	Alarm		
LED Response to Magnetic Test *			
LED Indication	Followed By	Status	Action
LED turns ON	Alarm is initiated	<b>Normal</b> , sensitivity is within compensation range	None
LED pulses <i>quickly</i> , 6 times in 3 seconds, then turns ON	Alarm is initiated	<b>More sensitive</b> , out of normal compensation range	Cleaning or other <b>service is required</b>
LED pulses <i>slowly</i> , 4 times in 8 seconds, then turns ON	Alarm is initiated	<b>Less sensitive</b> , out of normal compensation range	
	Does not initiate Alarm	<b>Detector is malfunctioning</b>	<b>Service is required</b>

\* Testing requires placing a magnet at the designated location on the detector cover for 4 seconds.

### Dimensions and Reference Information

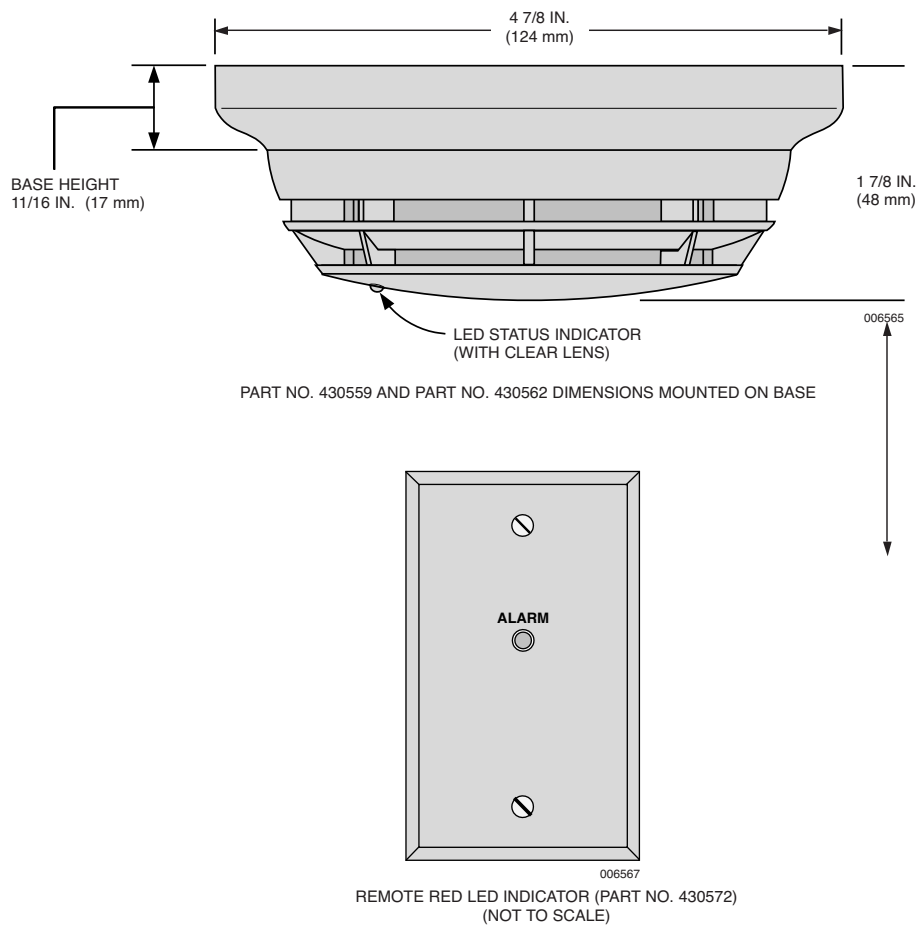



# Mounting Information

**ELECTRICAL BOX REQUIREMENTS:**

**WITHOUT RELAY** (BASE, PART NO. 430567):  
 4 IN. (102 mm) OCTAGONAL OR 4 IN. (102 mm) SQUARE, 1 1/2 IN. (38 mm) DEEP  
 SINGLE GANG, 2 IN. (51 mm) DEEP

**WITH RELAY** (BASE, PART NO. 430569):  
 4 IN. (102 mm) OCTAGONAL, 1 1/2 IN. (38 mm) DEEP, WITH 1 1/2 IN. (38 mm) EXTENSION RING  
 4 IN. (102 mm) SQUARE, 1 1/2 IN. (38 mm) DEEP, WITH 1 1/2 IN. (38 mm) EXTENSION RING

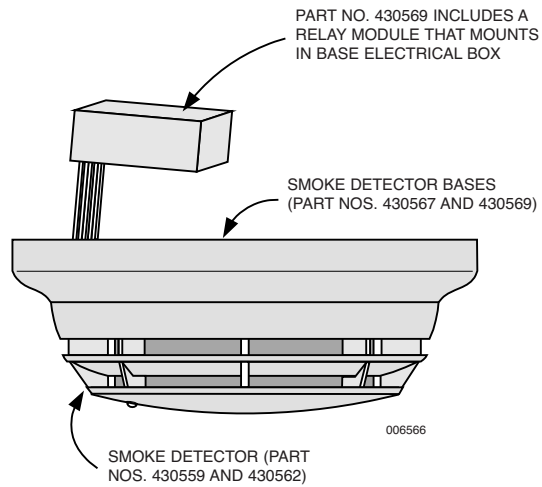
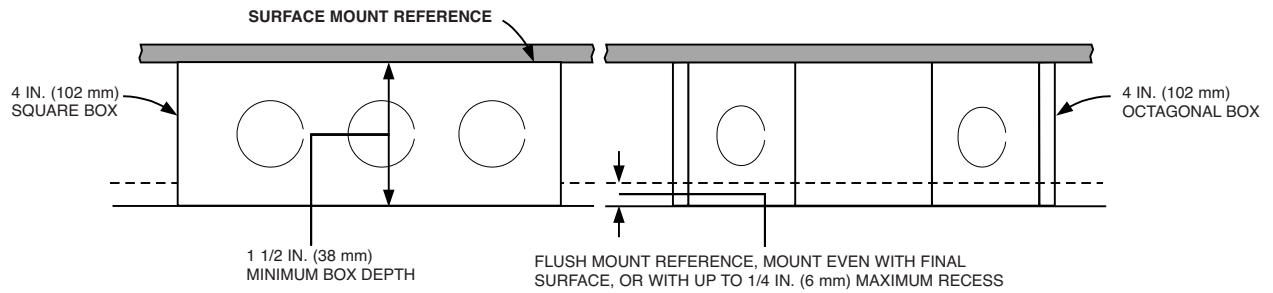



## Electronic Heat Detectors For Two-Wire Bases (Z-10)

### Features

**Accurate and reliable heat detection for protection of property**

**Available with rate-of-rise temperature detection:**

- Dual thermistor rate-of-rise operation
- For use where anticipated ambient temperature changes are less than 6 °F/minute (3.33 °C/minute)

**Epoxy encapsulated electronic design provides:**

- Easily tested, self-restoring operation with repeatable accuracy
- Alarm indicating LED located on detector
- Current limited alarm that is compatible with two wire initiating device circuits (IDCs)

**Optional remote alarm indicating LED**

**Available base options:**

- Bases for 2-wire operation
- Auxiliary relay output (refer to selection chart on for relay ratings)
- Remote alarm indicating LED output

### Description

Rate-of-rise detection is determined by comparing two thermistor responses. By combining accurate thermistors with proper physical placement, this patented rate-of-rise detection design achieves a high level of performance not normally available with mechanical detection.

### Listings and Approvals

- UL Listed: S6651
- ULC Listed: S6651
- FM Approved: 3015976
- CSFM (Approved)
- MEA (NYC) (Approved)

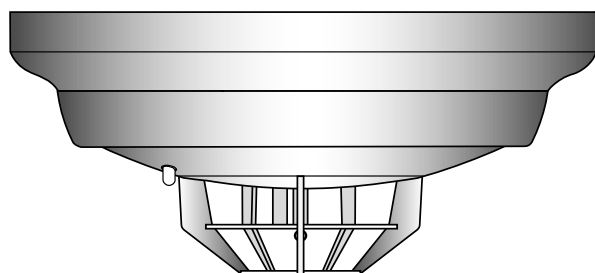

**Electronic Heat Detector Mounted in Base**

### Specifications

Voltage	15 to 32 VDC (filtered DC with 30% maximum ripple)
Standby Current	80 $\mu$ A typical, 100 $\mu$ A maximum
Alarm Current, 2-Wire Operation	Up to 100 $\mu$ A maximum, exact current is determined by alarm current limiting of connected IDC
Rate-of-Rise Operation	Meets FM requirements for operation between 15° and 25 °F/min (8.33° and 13.88 °C/min)
Humidity Range	10% to 95% RH from 32° to 122 °F (0° to 50 °C), not intended for outdoor applications
Color	Frost-White
Dimensions	Refer to diagram on page 3
<b>Ambient Temperature Operating Range</b>	
135° F Models	32° to 100 °F (0° to 38 °C)
200° F Models	32° to 150 °F (0° to 66 °C)

### WARNING

**Hazardous levels of smoke and toxic gas can build up before the heat detection device initiates an alarm. To ensure the safety of personnel, the use of smoke detection is highly recommended.**

### Applications Reference

Heat detectors are used where property protection is desired and where life safety protection is not required or is performed by other equipment.

The rate-of-rise operation provides heat detection for use where temperature fluctuations are controlled and are less than 6 °F/min (3.33 °C/min). Where temperatures may fluctuate more quickly, use fixed temperature detection.

Refer to NFPA 72, the *National Fire Alarm Code*, for additional guidance in applying and locating heat detectors.

### Alarm Indicating LED Operation

The heat detector LED turns ON continuously when in alarm. During normal conditions the LED is OFF.

Electronic heat detector design is protected by the following U.S. Patents: 5,450,066; DES.377,460.

006570

### Heat Detector Selection Chart

Part No.	Fixed Temperature Operation at	Rate-of-Rise Operation
430565	135 °F (57 °C)	Between 15° and 25° F/min (8.33° and 13.88° C/min)
430566	200 °F (93 °C)	

### Heat Detector Base Selection Chart

Smoke Detectors			
Part No.	Description	Connection	Details
430567	<b>2-Wire Base</b> , with connections for remote LED alarm indicator	IDC connections	Screw terminals for in/out wiring, 18 to 14 AWG
430570	<b>2-Wire Base</b> with remote LED alarm indicator	IDC connections	Screw terminals for 18 to 14 AWG for in/out wiring of zone (+), color coded 18 AWG leads for in/out wiring of zone (-)
		LED connections	Color coded 18 AWG leads
430569	<b>2-Wire Base</b> with auxiliary alarm relay output  <b>Note:</b> Must be connected as the only device on the IDC to ensure relay operation.	<b>Relay Operation Type</b>	<b>Relay Ratings</b>
		Power-limited	1 A @ 28 VDC Dual Form "C" contacts, for suppressed loads
		Nonpower-limited	3 A @ 120 AC
		<b>Output Type</b>	<b>Wiring Connections</b>
		IDC connections	Screw terminals for 18 to 14 AWG for in/out wiring of zone (+), color coded 18 AWG leads for in/out wiring of zone (-)
		Relay connections	Color coded 18 AWG leads

### Heat Detector Accessories

Part No.	Description	Details	Base Compatibility
430572	Remote Red LED Alarm Indicator	Mounted on single gang stainless steel plate, wiring connections are 18 AWG color coded leads	Part No. 430570 only
430573	End-of-Line Relay	Epoxy encapsulated design, 24 VDC operation, wiring connections are 18 AWG color coded leads	—

Metric wire equivalents: 18 AWG = 0.82 mm<sup>2</sup>; 14 AWG = 2.08 mm<sup>2</sup>

**Dimensions and Reference Information**

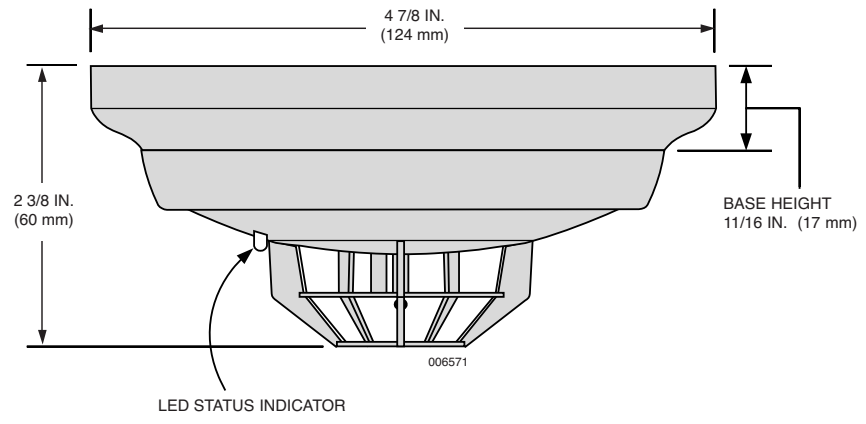

REMOTE RED LED INDICATOR (PART NO. 430572)  
(NOT TO SCALE)

## Mounting Information

Base	Electrical Box Requirements
430567	4 in. (102 mm) octagonal or 4 in. (102 mm) square box, 1-1/2 in. (38 mm) deep Single gang box, 2 in. (51 mm) deep
430569 430570	4 in. (102 mm) octagonal or 4 in. (102 mm) square box, 1-1/2 in. (38 mm) deep with 1-1/2 in. (38 mm) deep extension ring (see diagram below)

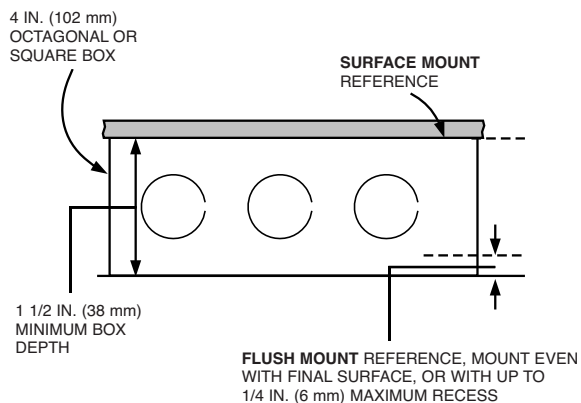

BASE (PART NO. 430569) INCLUDES A RELAY THAT MOUNTS IN BASE ELECTRIC BOX  
 BASE (PART NO. 430570) INCLUDES A REMOTE LED INTERFACE MODULE THAT MOUNTS IN BASE ELECTRICAL BOX

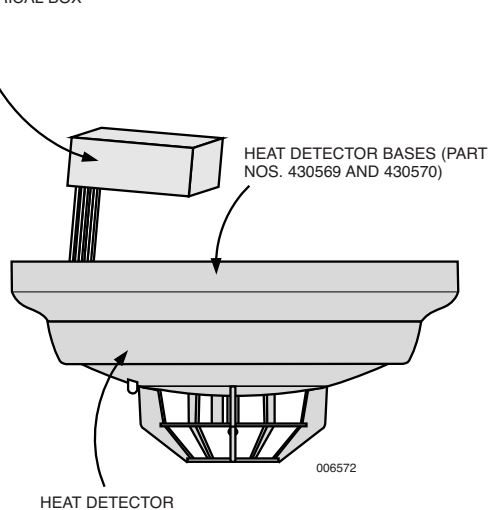



## Abort Switches and Releasing Appliance Circuit (RAC) Maintenance Switches (Z-10)

### Features

- **Abort switches provide a manual Fire Suppression System release abort request:**
  - Pushbutton momentary switch is mounted on a stainless steel single-gang plate
  - A protruding collar protects the switch from accidental contact (collar is removable if required)
  - Available flush or surface mount
  - Flush mounting requires standard single-gang box
  - Surface mounting includes a red mounting box
  - Models are available with internal 1.2kΩ resistor for current limited operation
- **Maintenance switches provide a secure and visible disconnect means for servicing Fire Suppression System Releasing Appliance Circuits (RACs):**
  - Maintained position keyswitch is mounted on a stainless steel double-gang plate
  - Key is removable in either normal or disabled position
  - Disabled position opens connection to output circuit to initiate a supervisory condition at the host panel
  - Disconnect indicator lamp is a bright incandescent bulb with red lens, powered from separate 24 VDC
  - Available for flush or surface mount
  - Flush mounting requires a standard double-gang box
  - Surface mount models include a red mounting box
- **UL listed to Standard 864, 9th Edition**

### Description

Releasing systems typically require maintenance disconnect switches and often require abort switches. These abort and maintenance switches are clearly labeled and combine easy operation with rugged construction for high integrity operation.

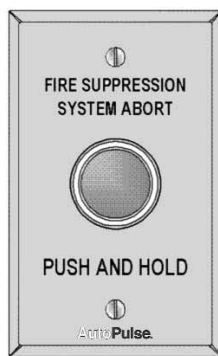

**Abort Switch**



**Maintenance Switch with Disconnect Indicator Lamp**

### Specifications

Electrical Ratings	
Abort Switch; One Contact block	Silver contacts; 1 NO & 1 NC; rated 2 A resistive @ 30 VDC
Maintenance Switch with Lamp; Two Contact blocks	Circuit control: Silver contacts; 1 NO & 1 NC; rated 2A resistive @ 30 VDC
	Lamp control: Silver contacts; 1 Form C; rated 2 A resistive @ 30 VDC
Maintenance Switch Indicator Light	Replaceable 2 W incandescent bulb; 24 to 30 VDC typical; 83 mA @ 35 VDC; requires -separate 24 VDC
Wiring Connections	
Abort Switch	Terminal blocks for in/out wiring; 18 to 14 AWG wire (0.82 mm <sup>2</sup> to 2.08 mm <sup>2</sup> )
Abort Switch with Current Limited Resistor	Terminal blocks for first wire connection; 18 to 14 AWG wire (0.82 mm <sup>2</sup> to 2.08 mm <sup>2</sup> ); 18 AWG wire lead for second wire connection
Maintenance Switch	18 AWG (0.82 mm <sup>2</sup> ) color coded wire leads for suppression circuit; terminal blocks for lamp wiring; 18 to 14 AWG wire (0.82 mm <sup>2</sup> to 2.08 mm <sup>2</sup> )
Environmental Ratings	
Temperature Range	32 °F to 120 °F (0 °C to 49 °C)
Humidity Range	Up to 93% at 90 °F (32 °C)

**Abort Switch Installation Reference**

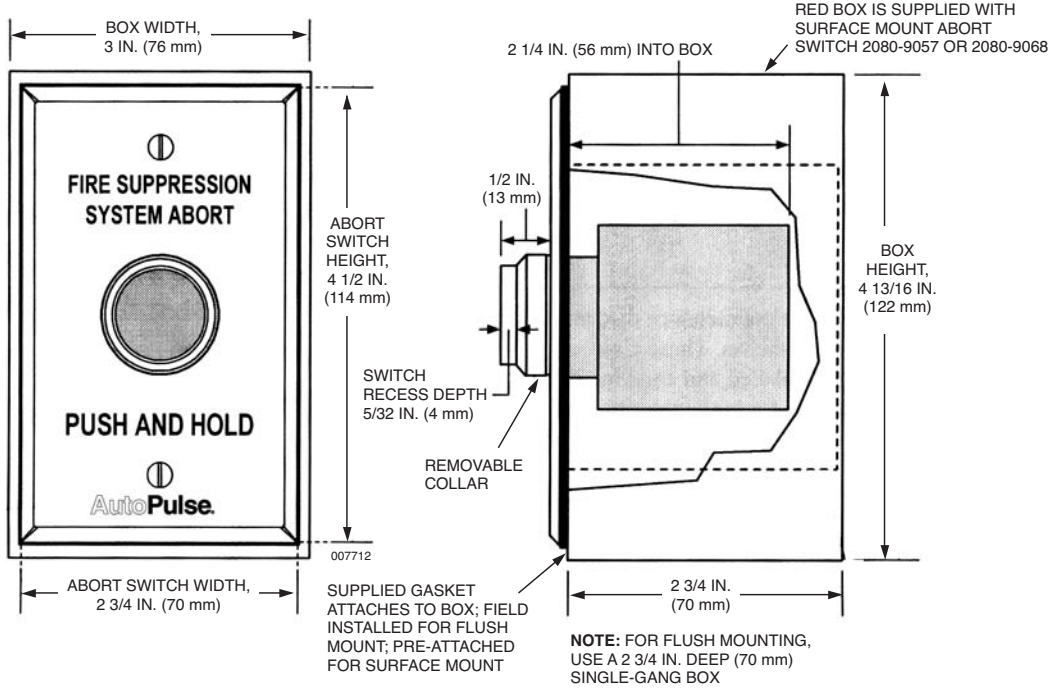

**Maintenance Switch Installation Reference**

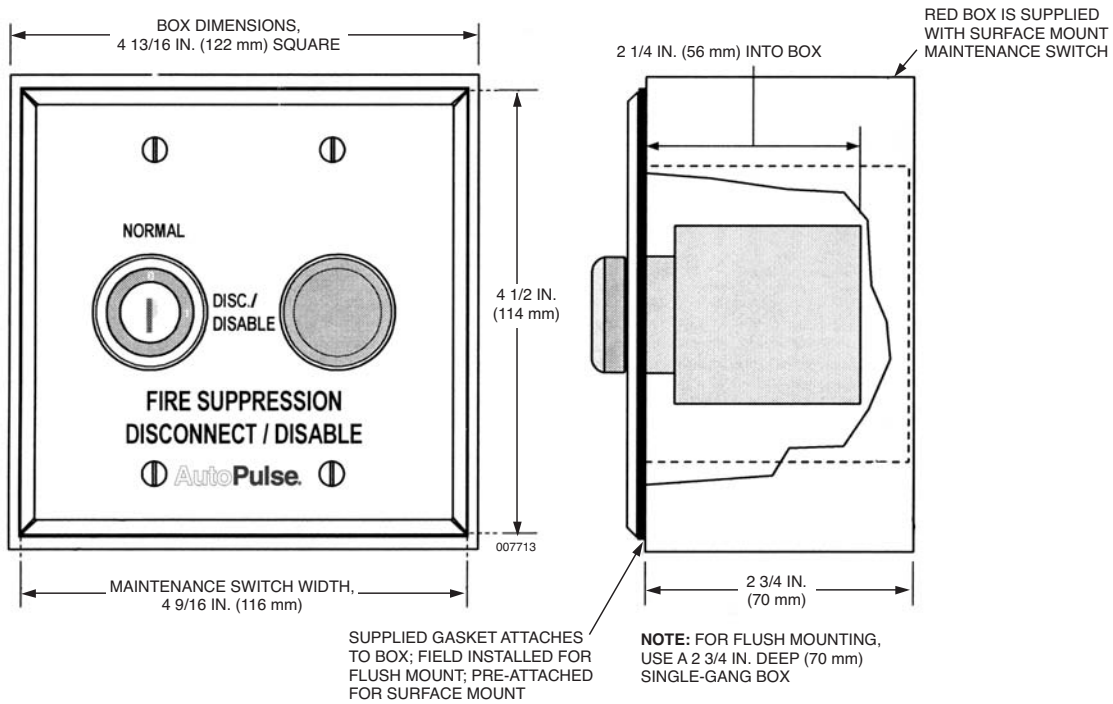

**Listings and Approvals**

- UL Listed . . . . . S8332
- ULC Listed . . . . . S8332
- CSFM . . . . . Approved
- MEA (NYC) . . . . . Approved

**Ordering Information**

Part No.	Description	Shipping Weight	
		lb	(kg)
433936	Flush Mount Maintenance Switch	2	(0.9)
433937	Surface Mount Maintenance Switch	2	(0.9)
433940	Flush Mount Abort Switch	1	(0.5)





## Isolated Loop Circuit Protector, Part No. 430685 (Z-10)

### Features

- **Isolated Loop Circuit Protector (ILCP) for up to 5 A of DC or audio current:**
  - ▶ **DC or audio current:**
    - Low impedance design minimizes voltage drop
    - For internal or external applications (refer to page 2 for external wiring requirements)
    - Refer to specific panel field wiring diagrams for additional application information
- **Operation is compatible with\*\*:**
  - DC notification appliance circuits (NACs)
  - Speaker circuit NACs (25 VRMS)
- **Multiple stages of protection for DC and audio circuits:**
  - Line-to-Line Protection
  - Line-to-Earth Protection
- **Rugged epoxy encapsulated package**

### Description

Electrical transients caused by lightning or by disturbances on high voltage power lines are conditions that require low voltage wiring circuits to be adequately protected. This protection is most effective when placed at the location where such circuits leave or enter the building.

The Isolated Loop Circuit Protector (ILCP) (Part No. 430685) is designed to protect Fire Alarm circuits from those electrical transients induced on wire runs that are routed external to the building. Because of its small package size, it can be easily mounted at the location that achieves maximum protection.

▶ \*\* Performance of this device has been quantified for use with other circuit types for specific applications where its low resistance is desired.

### Listings and Approvals

UL Listed . . . . . E197916

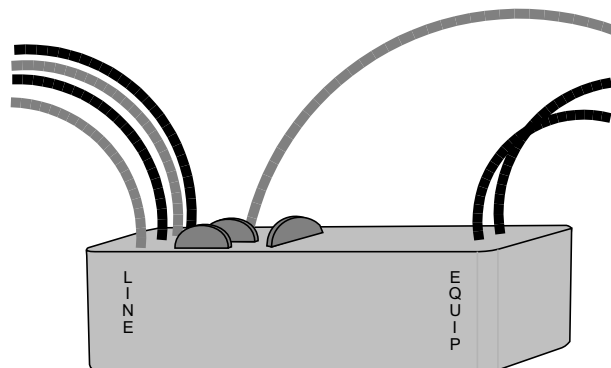

Isolated Loop Circuit Protector (Part No. 430685)

006581

### Operating Specifications

Line-to-Line Rating	38 VDC, 28 VAC RMS
Line-to-Ground Rating	
Shield-to-Ground Rating	48 VDC, 33 VAC RMS
Continuous Current Rating	5 A
Series Resistance	0.1 $\Omega$ /line
Series Inductance	68 $\mu$ H/line
Shunt Capacitance	0.017 $\mu$ F
Response Time	<1 Nanosecond ( $10^{-9}$ ) line-to-line and line-to-earth
Maximum Current Line-to-Line and Line-to-Earth	2000 A (8 x 20 $\mu$ sec pulse)
Maximum Current Shield-to-Earth	5000 A (10 x 50 $\mu$ sec)
<b>Mechanical Specifications</b>	
Dimensions	3 3/8 in. W x 2 in. D x 1 in. H (86 mm x 50 mm x 25 mm)
Package	Epoxy encapsulated, beige
Electrical box requirement	4 in. (102 mm) square box, 2 1/8 in. (54 mm) minimum depth
Wire Leads	Color coded, #18 AWG, 8 in. long (203 mm)

## External Wiring Requirements

Fire alarm system wiring that is run external to the building and is protected by the use of ILCPs shall be installed in accordance with the individual system component's installation instructions including properly grounded, twisted and shielded pairs, and observance of the following precautions.

**Location.** To ensure optimized protection, the ILCPs shall be located as close as possible to the point at which the circuits leave or enter the buildings and installed in dedicated metallic electrical boxes.

**Wiring Distance.** Wiring is limited to one contiguous property. The total maximum wire length is determined by the individual application's allowable limit as specified with ILCPs, but must not exceed 3270 ft (996.7 m).

**Underground Wiring.** Wiring must be in a wiring trough that is separate from commercial power distribution wiring.

## Overhead Wiring

1. Wiring must be run on poles separate from those supporting any commercial power distribution wiring.
2. Wiring shall be run in parallel with the commercial power distribution wiring and be separated by a minimum distance of either 100 ft (30 m) or the maximum span between any two adjacent poles of either the system's circuit or the commercial power distribution circuit.

**The grounding conductor** shall be #12 AWG with a maximum length of 28 ft (8.5 m), run in as straight a line as possible and connected to the building grounding electrode system (unified earth ground) per Article 800-40 of NFPA 70, the National Electrical Code.

## Typical Connections

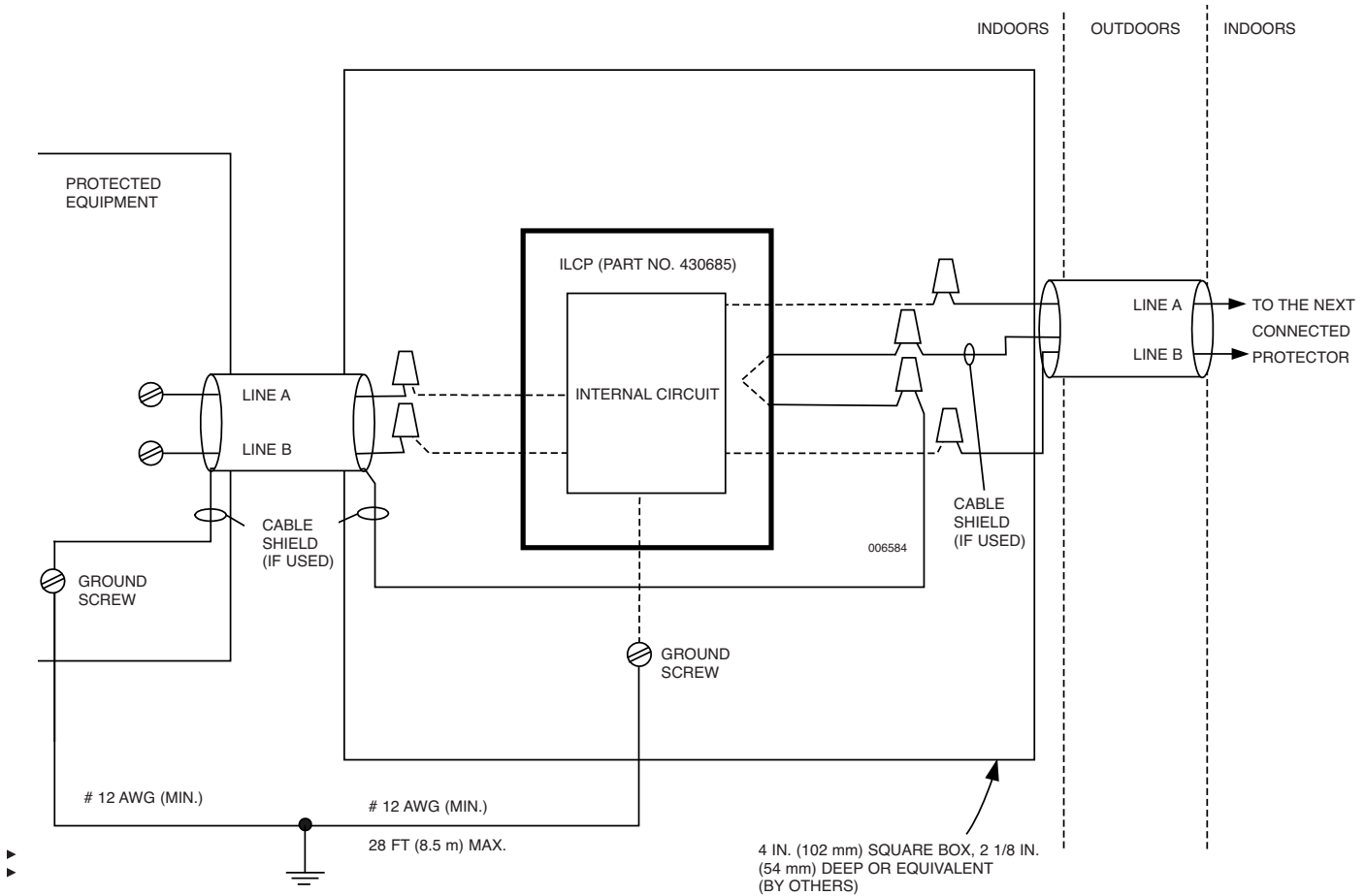



## ANSUL AUTOMAN II-C Releasing Device

### Applications

The ANSUL AUTOMAN II-C is an automatic, electric pneumatic releasing device for actuating a fire suppression system upon receipt of an electrical input signal. It may be automatically actuated via a detection/control system and/or manually through use of an integral manual strike button; or through use of a remote electric or remote mechanical pull station.

### Description

The device is made up of an enclosure, releasing device and auxiliary switch. The NEMA Type I all-steel enclosure has four holes for surface mounting and a hinged cover with key lock. The cover contains a window for visual verification that the releasing device is armed. A standard pattern of wiring knockouts is provided, and connections are made to heavy duty screw terminals – no soldering required.

The releasing device has a stored pressure cartridge (order separately) and provides pneumatic actuation for the release mechanisms on agent container tanks. Pressure is released from the cartridge by piercing the cartridge seal with a mechanical puncture pin. The pin release can be accomplished manually through a STRIKE button on the front cover or automatically through the solenoid. Optional electric or mechanical manual pull stations provide additional actuation capability, if desired. An auxiliary switch may be used to provide shutdown of equipment or provide feedback of actuation to the detection/control system.

### Technical Information

- Temperature Range: . . . +32 °F to +120 °F (0 °C to +49 °C)
- Solenoid Voltage: . . . . . 24 VDC Nominal
- Solenoid Operating Current: . . . . . 750 mA @ 24 VDC
- Solenoid on Time: . . . . . 50 mS
- Coil Resistance: . . . . . 26Ω
- Auxiliary Switch Contact Ratings: . . . . . 20A, 125/250VAC  
2 HP, 250VAC  
1 HP, 125VAC
- Weight: . . . . . 26 lb (11.8 kg)
- Overall Dimensions:

  - Height. . . . . 24.5 in. (662 mm)
  - Width . . . . . 12.5 in. (311 mm)
  - Depth . . . . . 4.25 in. (108 mm)

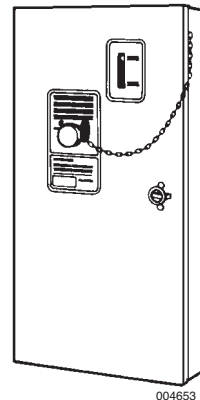

004653

The release contains a second integral switch which shuts off the solenoid after operation, approximately 50 mS. Supervision can be accomplished by passing a limited current of 50 mA or less through the solenoid circuit.

The number of devices that can be operated from the pneumatic output of one ANSUL AUTOMAN II-C is determined by the minimum anticipated temperature, the amount of piping required, and the nature of the devices being actuated. If additional actuation capability should ever be required as an option, remote pressure booster type actuators can readily fill the need.

### MOUNTING DIMENSIONS

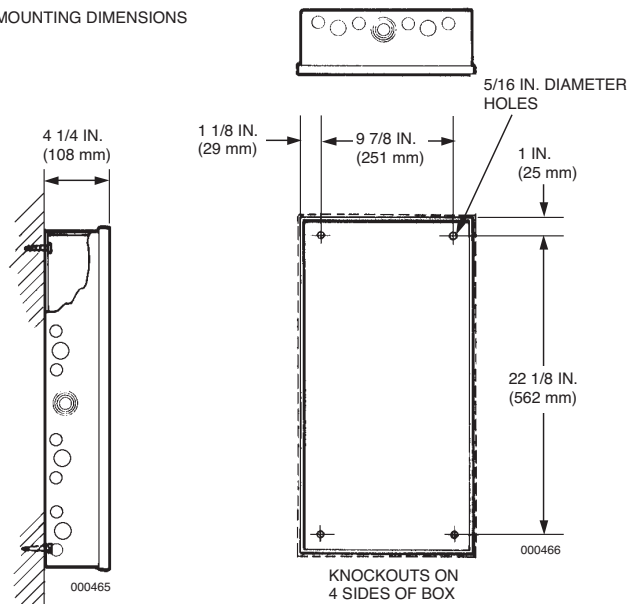

000465

000466

## Approvals

The ANSUL AUTOMAN II-C releasing device is Underwriters Laboratories listed for use with piped, fixed nozzle fire suppression systems (R5998). It complies with the requirements of all current applicable NFPA standards covering fire extinguishing agent systems.

## Ordering Information

Part No.	Description	Shipping Weight	
		lb	(kg)
17728	ANSUL AUTOMAN II-C Assembly	26	(11.8)
35619	Weatherproof ANSUL AUTOMAN II-C Assembly	28	(12.7)
17966	Lock with 2 Keys	0.25	(0.1)
70480	Key	0.1	(0.05)



## ANSUL AUTOMAN II-C Explosion-Proof Releasing Device

### Applications

The explosion-proof ANSUL AUTOMAN II-C is an automatic, electric pneumatic releasing device which, upon receipt of an electrical input signal, actuates the fire suppression system which is installed in a hazardous location.

It may be automatically actuated via a detection/control system and/or manually through use of an integral manual strike button; or through use of a remote electric or, mechanical remote pull station.

### Description

The device is made up of an enclosure, and releasing device. The NEMA Type I all steel enclosure has four holes for surface mounting and a hinged cover with key lock. The cover contains a window for visual verification that the releasing device is armed. Wiring knockouts are provided, and connections are made to the solenoid through two 18 AWG leads exiting the conduit fitting on the explosion-proof solenoid.

The releasing device uses a stored pressure nitrogen cartridge and provides pneumatic actuation for the agent container tank valve. Pressure is released by piercing the cartridge seal with a mechanical puncture pin. The pin release can be accomplished manually through a STRIKE button on the front cover or automatically through the solenoid. Optional electric or mechanical manual pull stations provide additional actuation capability, if desired.

To provide shutdown of equipment or provide feedback of actuation to the detection/control equipment, an explosion-proof pressure switch (not provided) can be added to the system.

The explosion-proof releasing device is suitable for use in the following areas: Class I, Groups C and D Hazardous Locations.

### Technical Information

Temperature Range:	. . . . . 32 °F to 130 °F (0 °C to 54 °C)		
Part Number:	31492	32525	32526
Operating Voltage:	. . . . . 24 VDC	120 VAC	240 VAC
Operating Current:	. . . . . 500 mA	100 mA	50 mA
Coil Resistance:	. . . . . 52 ohms	100 ohms	200 ohms
Solenoid Rating:	. . . . . Explosion-proof, Continuous Duty		
Weight:	. . . . . 26 lb (11.8 kg)		
Overall Dimensions:			
Height:	. . . . . 24.5 in. (622 mm)		
Width:	. . . . . 12.5 in. (311 mm)		
Depth:	. . . . . 4.25 in. (108 mm)		

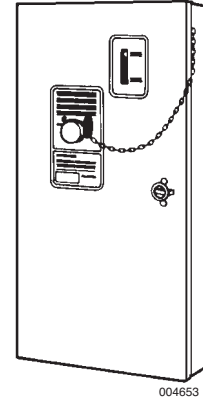

004653

### CAUTION

The explosion-proof ANSUL AUTOMAN II-C **CANNOT** be used with a CO<sub>2</sub> Cartridge. Although other cartridges will fit, they **MUST NEVER** be used in this unit.

Use only the LT-30-R Nitrogen cartridge (Part No. 5373).

The solenoid employed is rated for continuous duty. Should it be desirable to interrupt power to the solenoid after system actuation, an explosion-proof pressure switch can be utilized.

The number of devices that can be operated from the pneumatic output of one ANSUL AUTOMAN II-C is determined by the minimum anticipated temperature, the amount of piping required, and the required pressure to operate the devices being actuated. If additional actuation capability should ever be required, as an option, remote pressure booster type actuators can readily fill the need.

### MOUNTING DIMENSIONS

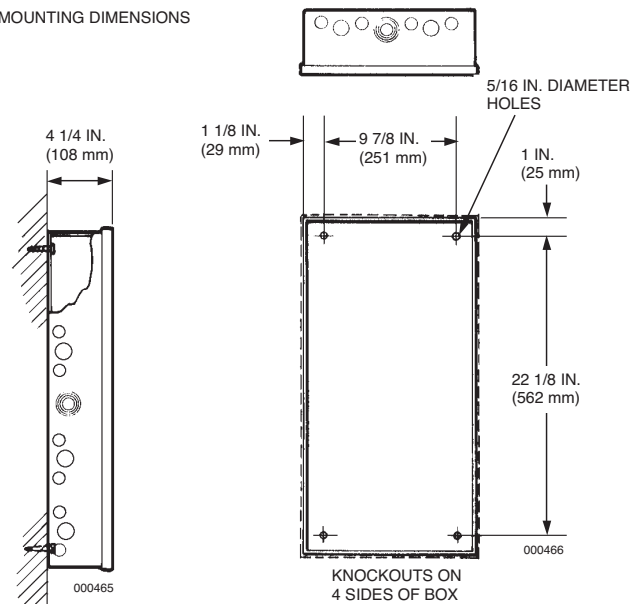

## Listings and Approvals

The ANSUL AUTOMAN II-C explosion-proof releasing device is Underwriters Laboratories listed (E62842) for use in Class 1, Groups C and D Hazardous Locations with piped, fixed nozzle fire suppression systems.

It complies with the requirements of all current applicable NFPA Standards covering fire extinguishing agent systems.

## Ordering Information

Part No.	Description	Shipping Weight	
		lb	(kg)
31492	ANSUL AUTOMAN II-C Explosion-Proof Releasing Device, 24 VDC	26	(11.8)
32525	ANSUL AUTOMAN II-C Explosion-Proof Releasing Device, 120 VAC	26	(11.8)
32526	ANSUL AUTOMAN II-C Explosion-Proof Releasing Device, 240 VAC	26	(11.8)